

STANDARD FOOD AND BEVERAGE CONCESSION AGREEMENT

BETWEEN

CITY AND COUNTY OF DENVER

AND

HOST-CTI DEN F&B II, LLC

dba CRU' - A WINE BAR

AT

DENVER INTERNATIONAL AIRPORT

STANDARD FOOD AND BEVERAGE CONCESSION AGREEMENT

DENVER INTERNATIONAL AIRPORT

SUMMARY PAGE

HOST-CTI DEN F&B II, LLC

This Summary Page, consisting of three pages, is attached to and made a part of that certain Agreement made and entered into as of the date stated on the signature page, between the City and County of Denver and the Concessionaire listed below.

CONCESSIONAIRE: Name	Host-CTI DEN F&B II, LLC
Address for Notice	6905 Rockledge Drive,
City, State and Zip	Bethesda, MD 20817
Contact	General Counsel and Stephen E. Douglas
Trade Name	Cru' - A Wine Bar
State of Incorporation	Delaware

CONCESSION LOCATION and RENT (Initial)						
Loca Num	Concourse /Terminal	Address	Square Feet	Initial MAG	Initial Monthly MAG	Minimum Investment PSF
1	Concourse B East Outboard Subcore	R18-1-3-E36-N2-1	934.90	\$ 203,932.00	\$ 16,994.00	\$ 719.11

PERCENTAGE RENT:

*Up to \$1 Million	10%
*\$1 Million - \$2 Million	12%
*Over \$2 Million	14%
Alcohol Gross Revenues	17%
*of (non alcohol) Gross Revenues as defined in Section 5.02	

INTERIM RENT AMOUNT: \$ 19,993.00 (based on projected annual sales)

PERFORMANCE SURETY AMOUNT: \$ 101,966.00 or as provided in Section 9.03

MARKETING ASSESSMENT: 1.00% of Gross Revenues as provided in Section 13.01

STORAGE SPACE LEASE: n/a

SK
Initialed by Concessionaire

TERM: 7 years from the Required Opening date as documented by *Exhibit D*

Effective Date: Date of Execution

Expiration Date: 7 years from the Required Opening Date, which is December 31, 2019 unless modified by Section 6.12 and documented by *Exhibit D*

PERMITTED USE: Operation of a high-quality Food and Beverage concession at DIA, offering for sale the following Products: Wines by the glass (or bottle if consumed in Wine Bar location). Small plate food items as well as other non-alcoholic beverages including soft drinks. Retail sale of wine-related accessories, gifts and other items as approved by the City and Approved Product or Services List attached hereto as *Exhibit E*.

Major Concession Category Food and Beverage

Minor Concession Category Bar

Brand(s) Cru'

Approved Product List See Approved Product List attached hereto as *Exhibit E*.

Express Restrictions: All wine sold must be consumed on the premises. Bottles of wine may not be sold for shipping or be taken from the store location. Gourmet coffee or tea is not allowed. Only the warming of food will be allowed in the concession space.

HOURS OF OPERATION: 6:00 AM - 10:00 PM, Not less than 16 hours each day, seven days per week, or as as they may be adjusted pursuant to Section 7.07

TARGET POSSESSION DATE: Estimated to be June 7, 2012, If different, then date of actual possession to be documented in *Exhibit D*.

REQUIRED OPENING DATE: December 5, 2012 unless modified by Section 6.12 and documented by *Exhibit D*

RENT COMMENCEMENT DATE December 5, 2012 unless modified by Section 6.12 and documented by *Exhibit D1*

 Initialed by Concessionaire

REQUIRED MINIMUM INVESTMENT: \$672,295.00 (934.90 s.f. x \$719)

REFURBISHMENT MINIMUM INVESTMENT: The Refurbishment Minimum Investment shall be 20% of the Required Minimum Investment (including equipment) or \$134,459.00 in which case, a minimum of 50% shall be aesthetic refurbishment.

REFURBISHMENT COMPLETION DATE: Saturday, December 05, 2015 or as modified by Section 6.12 and documented by *Exhibit D*

INSURANCE POLICY AMOUNTS:
Comprehensive General Liability: See Exhibit C
Automobile/Delivery Vehicle Liability: See Exhibit C
Workers Compensation: Statutory requirements
Alcohol Liability: If applicable, see Exhibit C

ACDBE GOAL: 20 %

DESCRIPTION OF EXHIBITS AND ADDENDA:
Exhibit A Concession Space Plan
Exhibit B Disadvantaged Business Enterprise Participation
Exhibit C Insurance Certificate
Exhibit D Confirmation Letter
Exhibit D1 Letter Confirming Actual Dates of Certain Events
Exhibit E Approved Menu
Exhibit H Street Pricing Comparables
Exhibit I Independent Auditor's Report
Exhibit J Independent Accountant's Report on Applying Agreed-Upon Procedures
Exhibit K Deleted Intentionally
Exhibit L Concession Revenue Monthly Report
Exhibit N DIA Environmental Requirements
Exhibit X Provisions for Design and Construction of Improvements
Appendix 1 Standard Federal Assurances
Appendix 2 Standard Federal Assurances, Nondiscrimination
Appendix 3 Nondiscrimination in Airport Employment Opportunities
Appendix 10 Disadvantaged Business Enterprises – Required Statements

Initialed by Concessionaire

STANDARD FOOD AND BEVERAGE CONCESSION AGREEMENT

DENVER INTERNATIONAL AIRPORT

CONSTRUCTION SUMMARY PAGE

HOST-CTI DEN F&B II, LLC

This Construction Summary Page, consisting of one page, is attached to and made a part of that certain Agreement made and entered into as of the date stated on the signature page between the City and County of Denver and the Concessionaire named below.

CONCESSIONAIRE:

Name:	<u>Host-CTI DEN F&B II, LLC</u>
Trade Name:	<u>Cru' - A Wine Bar</u>
Address:	<u>6905 Rockledge Drive,</u>
City, State and Zip	<u>Bethesda, MD 20817</u>

DESIGN AND CONSTRUCTION DEADLINE:

December 5, 2012 or 180 days from actual possession per Section 6.02 or if modified by Section 6.12, then as documented in *Exhibit D*

CONSTRUCTION PERFORMANCE AND PAYMENT BOND AMOUNTS:

100% of construction contract price

CONSTRUCTION INSURANCE POLICY AMOUNTS:

Builder's Risk:	<u>100% of construction contract price</u>
Minimum Commercial General Liability:	
Combined Single Limit:	<u>\$1,000,000</u>
General Aggregate:	<u>\$2,000,000</u>
Business Auto Liability:	
Combined Single Limit:	<u>\$1,000,000</u>
Workers Compensation:	<u>Statutory requirements</u>

SBE DESIGN AND CONSTRUCTION GOALS:

\$ 0 < \$30,000 = 0%
\$30,000 - \$90,000 = 3%
\$90,000 < \$150,000 = 5%
> \$150,000 = Goals Committee



Initialed by Concessionaire

Table of Contents

SECTION 1 – GENERAL	1
1.01 CONSIDERATION	1
1.02 INCORPORATION OF ATTACHED SUMMARY PAGE, EXHIBITS AND ADDENDA ...	1
SECTION 2 – DEFINITIONS	2
2.01. AIRPORT	2
2.02. AIRPORT MASTER PLAN	2
2.03. APPROVED MENU	2
2.04. AUDITOR	2
2.05. BRAND	2
2.06. CONCESSION SPACE	2
2.07. CONCESSIONAIRE'S EQUIPMENT	3
2.08. CONCESSIONAIRE'S PROPOSAL	3
2.09. CONCOURSES	3
2.10. DIA DESIGN STANDARDS	3
2.11. DIA ENVIRONMENTAL GUIDELINES	3
2.12. DIA TENANT DEVELOPMENT GUIDELINES	3
2.13. EFFECTIVE DATE	3
2.14. EXHIBITS A, D, D1, E, H AND L	3
2.15. EXPIRATION DATE	4
2.16. GUARANTOR [RESERVED]	4
2.17. GROSS REVENUE	4
2.18. IMPROVEMENTS	4
2.19. INTERIM RENT	4
2.20. MANAGER	4
2.21. MANAGER'S AUTHORIZED REPRESENTATIVE	4
2.22. OPEN FOR BUSINESS	4
2.23. PAST DUE INTEREST RATE	5
2.24. POSSESSION DATE	5
2.25. RENT COMMENCEMENT DATE	5
2.26. REQUIRED OPENING DATE	5
2.27. TARGET POSSESSION DATE	5
2.28. TERMINAL	5
2.29. TERMINAL COMPLEX	5
2.30. VIBRANT FIRST-CLASS	5
SECTION 3 – GRANT OF CONCESSION RIGHTS	6
3.01. CONCESSION RIGHTS GRANTED	6
3.02. USE OF CONCESSION SPACE	6
3.03. RIGHTS NOT EXCLUSIVE	8
3.04. MEANS OF ACCESS	8
3.05. CITY'S RIGHT OF INSPECTION; ACCESS	8
SECTION 4 – TERM	9
4.01. TERM	9
4.02. SURRENDER OF CONCESSION SPACE	9

4.03.	HOLDING OVER.....	9
SECTION 5 – RENT		10
5.01.	RENT	10
5.02.	GROSS REVENUES.....	10
5.03.	MONTHLY REVENUE STATEMENTS AND PAYMENTS.....	11
5.04.	TITLE TO CITY’S COMPENSATION	13
5.05.	INTEREST ON PAST DUE AMOUNTS	13
5.06.	PLACE AND MANNER OF PAYMENTS	13
5.07.	APPLICATION OF PAYMENTS.....	13
5.08.	BOOKS OF ACCOUNT AND AUDITING	14
5.09.	RECOVERY OF CITY EXPENSE TO FULFILL CONCESSIONAIRE’S OBLIGATIONS	17
5.10.	REMEDIES NON-EXCLUSIVE	17
5.11.	REESTABLISHMENT OF RENTALS, FEES AND CHARGES.....	18
SECTION 6 – CONSTRUCTION RESPONSIBILITIES OF CONCESSIONAIRE.....		18
6.01.	“AS IS” CONDITION OF CONCESSION SPACE	18
6.02.	TIME TO COMPLETE DESIGN AND CONSTRUCTION	18
6.03.	APPROVAL OF PLANS AND SPECIFICATIONS FOR NEW SPACE.....	19
6.04.	FINAL PLANS.....	20
6.05.	NOTICE TO PROCEED	20
6.06.	CONSTRUCTION OF INITIAL IMPROVEMENTS	21
6.07.	CONSTRUCTION STANDARDS	21
6.08.	REQUIRED MINIMUM INVESTMENT	22
6.09.	COORDINATION OF CONSTRUCTION	22
6.10.	ENVIRONMENTAL REQUIREMENTS FOR CONSTRUCTION	22
6.11.	BUILDING PERMITS	23
6.12.	COMPLETION OF CONSTRUCTION	23
6.13.	RESTRICTION ON CHANGES AND ALTERATIONS.....	24
6.14.	REFURBISHMENT OF CONCESSION SPACE	25
6.15.	TITLE TO IMPROVEMENTS.....	27
6.16.	DUTIES UPON SURRENDER.....	27
SECTION 7 – CONCESSIONAIRE’S OPERATING OBLIGATIONS		28
7.01.	FIRST CLASS CONCESSION	28
7.02.	PRICING	28
7.03.	MENU CHANGES.....	30
7.04.	CREDIT CARDS AND DEBIT CARDS	30
7.05.	MANAGEMENT, SERVICE EMPLOYEE AND OPERATIONAL STANDARDS	30
7.06.	DELIVERIES.....	32
7.07.	HOURS.....	32
7.08.	SIGNS, WINDOW DISPLAYS AND ADVERTISING.....	33
7.09.	VENDING MACHINES	34
7.10.	COMPLIANCE WITH ALL LAWS AND REGULATIONS	34
7.11.	COMPLIANCE WITH ENVIRONMENTAL REGULATIONS	35
7.12.	WASTE OR IMPAIRMENT OF VALUE	36
7.13.	HAZARDOUS USE	36
7.14.	WASTE DISPOSAL AND RECYCLING	37

7.15.	SANITATION, HYGIENE AND CLEANLINESS	38
7.16.	MAINTENANCE OF CONCESSION SPACE BY CONCESSIONAIRE	39
7.17.	STRUCTURAL, ELECTRICAL OR SYSTEM OVERLOADING	40
7.18.	NOISE, ODORS, VIBRATIONS AND ANNOYANCES	40
7.19.	ACCESS TO FACILITY AND SYSTEMS.....	41
7.20.	QUALITY ASSURANCE	41
SECTION 8 – UTILITIES AND SERVICES.....		42
8.01.	UTILITIES	42
8.02.	HEATING AND AIR CONDITIONING (HVAC).....	42
8.03.	WATER SERVICE	42
8.04.	ELECTRICITY AND NATURAL GAS.....	42
8.05.	LIGHTING	43
8.06.	WINDOW WASHING AND STRUCTURAL MAINTENANCE	43
8.07.	COMMON USE SERVICES.....	43
8.08.	INTERRUPTION OF SERVICES	43
SECTION 9 – INDEMNITY, INSURANCE AND GUARANTEES		43
9.01.	INDEMNITY	43
9.02.	INSURANCE.....	44
9.03.	PERFORMANCE SURETY.....	46
9.04.	NO PERSONAL LIABILITY	48
9.05.	LICENSES, FEES, TAXES AND LIENS	48
SECTION 10 –NON-COMPLIANCE AND VIOLATIONS		49
10.01.	NONCOMPLIANCE	49
10.02.	CUMULATIVE OR CONTINUOUS VIOLATIONS.....	50
SECTION 11 –DEFAULT, REMEDIES AND TERMINATION.....		51
11.01.	DEFAULT	51
11.02.	REMEDIES	53
11.03.	REMEDIES CUMULATIVE	55
11.04.	ADMINISTRATIVE HEARING.....	55
11.05.	WAIVERS	55
SECTION 12 – DAMAGE, DESTRUCTION OR LOSS.....		56
12.01.	DAMAGE TO OR DESTRUCTION OF CONCESSION SPACE.....	56
12.02.	COOPERATION IN THE EVENT OF LOSS.....	56
12.03.	LOSS OR DAMAGE TO PROPERTY.....	56
12.04.	MUTUAL WAIVER; INSURANCE COVERAGE	57
12.05.	RELEASE	57
SECTION 13 – PROMOTIONAL PROGRAM		57
13.01.	JOINT MARKETING FUND.....	57
13.02.	PREMIUM VALUE CONCESSIONS PROGRAM	58
SECTION 14 – MISCELLANEOUS PROVISIONS		59
14.01.	AGREEMENT BINDING UPON SUCCESSORS	59
14.02.	AGREEMENT MADE IN COLORADO; VENUE	59

14.03.	AGREEMENTS WITH THE UNITED STATES	59
14.04.	RIGHT TO DEVELOP AIRPORT	59
14.05.	AGREEMENT SUBJECT TO AVIATION PRIORITY	59
14.06.	MODIFICATIONS REQUIRED BY FAA	60
14.07.	ASSIGNMENT AND SUBLEASE	60
14.08.	BOND ORDINANCES	60
14.09.	FORCE MAJEURE	61
14.10.	INCONVENIENCES DURING CONSTRUCTION	61
14.11.	MASTER PLAN	61
14.12.	FUTURE CONCESSIONS PLANNING	61
14.13.	NONDISCRIMINATION	61
14.14.	NOT PARTNERSHIP	62
14.15.	NOTICES	62
14.16.	PARAGRAPH HEADINGS.....	62
14.17.	PATENTS AND TRADEMARKS.....	63
14.18.	COLORADO OPEN RECORDS ACT.....	63
14.19.	SECURITY.....	63
14.20.	SEVERABILITY	64
14.21.	AUTHORITY TO ENTER INTO AGREEMENT:	64
14.22.	NO CONSTRUCTION AGAINST DRAFTING PARTY	65
14.23.	THIRD PARTIES.....	65
14.24.	USE, POSSESSION OR SALE OF ALCOHOL OR DRUGS.....	65
14.25.	CITY SMOKING POLICY	65
14.26.	WAIVER OF CLAIMS.....	65
14.27.	NUMBER OR GENDER	66
14.28.	JOINT AND SEVERAL LIABILITY	66
14.29.	BROKER'S COMMISSION	66
14.30.	NO LIMIT ON CITY'S POWERS.....	66
14.31.	WAR OR NATIONAL EMERGENCY.....	66
14.32.	SURVIVAL OF CERTAIN CONTRACT PROVISIONS	66
14.33.	AGREEMENT AS COMPLETE INTEGRATION; AMENDMENTS.....	66
14.34.	FINAL APPROVAL; COUNTERPARTS.....	67
14.35.	ELECTRONIC SIGNATURES AND ELECTRONIC RECORDS	67

STANDARD AGREEMENT

THIS STANDARD AGREEMENT ("Agreement") is made and entered into as of the date stated on the signature page ("Effective Date"), by and between the **CITY AND COUNTY OF DENVER**, a municipal corporation of the State of Colorado, for and on behalf of its Department of Aviation (the "City"), Party of the First Part, and **HOST-CTI DEN F&B II, LLC**, a Delaware limited liability company authorized to conduct business in the State of Colorado ("Concessionaire"), d/b/a **Cru' - A Wine Bar**, Party of the Second Part.

RECITALS

WHEREAS, the City owns, operates and maintains Denver International Airport; and

WHEREAS, the City operates a concession program at the Airport which is envisioned to be *among the best in the world offering value, excitement and a wide range of culinary and retail experiences and services that evoke a strong sense of place reflecting the best of Denver, Colorado and the Rocky Mountain West*; and

WHEREAS, in that spirit, Concessionaire agrees to create and maintain a vibrant first-class concession at the Airport by providing value and great customer service (prompt, clean, courteous and efficient) in everything it does; by creating an engaging environment designed to entice and excite consumers, by offering quality food and beverages, retail merchandise and/or services in the branded environment agreed to by the Parties, and by keeping its concession program fresh and dynamic thereby maximizing its revenue potential; and

WHEREAS, acting pursuant to a competitive solicitation process in which Concessionaire was recommended to operate in the Concession Space, the City negotiated this Agreement with Concessionaire for a food and beverage concession at the Airport to be operated in accordance with the terms, conditions and requirements of this Agreement; and

WHEREAS, the premises set forth in these recitals are hereby made a part of this Agreement;

NOW THEREFORE, for good and valuable consideration the sufficiency of which hereby is acknowledged, the City and Concessionaire (collectively, the "Parties") intending to be legally bound by the terms and conditions of this Agreement, agree as follows:

SECTION 1 – GENERAL

1.01 CONSIDERATION

The City enters into this Agreement for and in consideration of the payment of compensation by Concessionaire as herein provided, the construction of all Improvements by Concessionaire as herein provided, the Brand Concessionaire is authorized to operate at Denver International Airport and the performance and observance by Concessionaire of the terms, conditions, requirements, covenants and agreements set forth herein.

1.02 INCORPORATION OF ATTACHED SUMMARY PAGE, EXHIBITS AND ADDENDA

The Summary Page attached to this Agreement, the Exhibits and Addenda attached to and referred to in this Agreement as described on the Summary Page and all general rules and

regulations adopted by the City or the Manager for the management, operation and control of the Airport, either promulgated by the City on its own initiative or in compliance with regulations or actions of the Federal Aviation Administration or other authorized federal agency, as they may be amended from time to time, are intended to be, and hereby are, deemed incorporated into this Agreement by this reference.

SECTION 2 – DEFINITIONS

In addition to other terms, which are defined elsewhere in this Agreement or any Exhibits, the terms defined in the following subsections of this Section 2 shall have the meaning, set forth in such subsection whenever used in this Agreement.

2.01. AIRPORT

"Airport" or "DIA" shall mean Denver International Airport.

2.02. AIRPORT MASTER PLAN

"Airport Master Plan" or "Master Plan" shall mean the approved master plan for development of Denver International Airport.

2.03. APPROVED MENU

"Approved Menu" shall mean the City-approved food and beverage menu attached hereto as *Exhibit E*.

2.04. AUDITOR

"Auditor" shall mean the City's Auditor and the Auditor's authorized representative.

2.05. BRAND

"Brand" shall mean the local, regional or national brand or brands, described on the Summary Page that was proposed by Concessionaire and accepted by the City as a material part of the consideration to the City for this Agreement. "Brand" shall include items set forth on *Exhibit E*, as it may be modified pursuant to Section 7.03. "Brand" shall include the plural where the context requires.

2.06. CONCESSION SPACE

"Concession Space" shall mean the space and facilities shown and described on the Concession Space Plan attached hereto as *Exhibit A*, located within the Terminal and/or the Concourses and containing the number of square feet set forth on the Summary Page. "Concession Space" shall include the plural where applicable. The City and Concessionaire acknowledge and agree that the dimensions of the Concession Space as set forth in *Exhibit A* and the Summary Page are approximate and that, following the completion of construction, the precise dimensions and square footage shall be determined by the Manager and a revision to the Summary Page and *Exhibit A* will be made, if necessary, depicting the dimensions and square footage of the Concession Space as actually constructed. The Manager may add or subtract square footage of up to 10% of the Concession Space (without a corresponding

adjustment to the MAG) with the prior written consent of the Concessionaire. Each of these actions may be taken without the requirement of a formal amendment to this Agreement.

2.07. CONCESSIONAIRE'S EQUIPMENT

"Concessionaire's Equipment" shall mean all equipment, apparatus, machinery, signs, furnishings, trade fixtures and other non-affixed personal property installed by Concessionaire and used in the operation of the business of Concessionaire (as distinguished from the use and operation of the Concession Space.)

2.08. CONCESSIONAIRE'S PROPOSAL

"Concessionaire's Proposal" shall mean the proposal as finally submitted by Concessionaire and accepted by City consisting of Concessionaire's plans for its design, Concessionaire's proposed brand, menu of food and beverage items Concessionaire proposes to sell at the Airport, pricing plans, and Concessionaire's entire plan of operation.

2.09. CONCOURSES

"Concourses" shall mean Concourses A, B and C located at the Airport but specifically excepts the Terminal as herein defined.

2.10. DIA DESIGN STANDARDS

"DIA Design Standards" shall mean the design standards and criteria established for Denver International Airport as such standards and criteria may be established or modified from time to time.

2.11. DIA ENVIRONMENTAL GUIDELINES

"DIA Environmental Guidelines" shall mean those portions of the environmental standards and criteria established for non-aviation tenant development and operations at the Airport, as they may hereafter be amended.

2.12. DIA TENANT DEVELOPMENT GUIDELINES

"DIA Tenant Development Guidelines" shall mean the criteria established at DIA for tenants and concessionaires for design, construction, installation, signage and related matters, as they may hereafter be amended.

2.13. EFFECTIVE DATE

"Effective Date" shall mean the date this Agreement commences and becomes fully effective and binding upon the Parties, which is the date this Agreement is executed by City.

2.14. EXHIBITS A, D, D1, E, H and L

The Parties agree that *Exhibits A, D, D1, E, H and L* may be modified from time to time as provided herein without the requirement of a formal amendment to this Agreement.

2.15. EXPIRATION DATE

“Expiration Date” shall mean the date after the Required Opening Date that this Agreement expires, which is the date listed on the Summary Page or as documented on *Exhibit D*, as provided herein.

2.16. GUARANTOR [Reserved]

2.17. GROSS REVENUE

“Gross Revenue” has the meaning given in Section 5.02.

2.18. IMPROVEMENTS

“Improvements,” or “Tenant Improvements,” which shall not include Concessionaire’s Equipment as defined in Section 2.07, shall mean any new construction, equipment, finishes, fixtures, systems, furnishings and furniture installed by Concessionaire, as well as modifications or alterations to existing construction, equipment, finishes, fixtures, systems, furnishings and furniture that conform to drawings and specifications approved in writing by the Manager’s authorized representative.

2.19. INTERIM RENT

“Interim Rent” shall mean the rental amount stated on the Summary Page that Concessionaire agrees to pay to the City during the period of time between the Required Opening Date and the date Concessionaire actually Opens for Business in accordance with the provisions of Section 6.12. The actual date Interim Rent commences shall be documented on *Exhibit D1*.

2.20. MANAGER

“Manager” shall mean the City’s Manager of Aviation or the Manager’s successor in function.

2.21. MANAGER’S AUTHORIZED REPRESENTATIVE

Whenever reference is made herein to the “Manager or the Manager’s authorized representative,” or words of similar import are used, the City’s Deputy Manager of Aviation/Commercial shall be such authorized representative of the Manager, unless written notice otherwise is given to the Concessionaire by the Manager. The Deputy Manager’s authorized representative is the Airport’s Concessions Director who designates the Airport’s Concessions Manager for day-to-day administration of this Agreement. Concessionaire shall submit its reports, memoranda, correspondence and submittals to the Concessions Manager. The Manager and the Deputy Manager may rescind or amend any such designation of representatives or delegation of City authority upon written notice to the Concessionaire.

2.22. OPEN FOR BUSINESS

The Concession Space shall be deemed open for business when Concessionaire has (i) delivered documentation satisfactory to the City of completion of construction of the Concession Space; (ii) obtained written permission from the Manager’s authorized representative to and thereafter removed the construction wall surrounding the Concession Space and (iii)

commenced generating sales and revenue from the Concession Space. The date Concessionaire actually opens for business will be confirmed by the Parties and documented on **Exhibit D1**.

2.23. PAST DUE INTEREST RATE

"Past Due Interest Rate" shall mean interest accruing at 18% per annum commencing on the fifth business day after the date such amount is due and owing until paid to City.

2.24. POSSESSION DATE

"Possession Date" shall mean the date on which the City actually delivers possession of the Concession Space to the Concessionaire or if earlier in time, the date included in any written correspondence from the City notifying Concessionaire that the Concession Space is ready for Concessionaire's use and occupancy.

2.25. RENT COMMENCEMENT DATE

"Rent Commencement Date" shall mean the date Concessionaire is obligated to first pay Rent, which is anticipated to be the date stated on the Summary Page. In all cases, however, the obligation to pay Rent commences on the first day Concessionaire is Open for Business. The actual date Rent commences shall be documented and made a part of this Agreement as **Exhibit D1**.

2.26. REQUIRED OPENING DATE

"Required Opening Date" shall mean the date Concessionaire is required to Open for Business, which is the date stated on the Summary Page. If modified, this date shall be confirmed and documented on **Exhibit D**.

2.27. TARGET POSSESSION DATE

Month, Day, Year stated on the Summary Page as the "Target Possession Date," is a nonbinding estimate of the date on which the Concession Space will be delivered to Concessionaire at which time Concessionaire shall commence the remodeling of the Concession Space pursuant to Concessionaire's construction obligation.

2.28. TERMINAL

"Terminal" shall mean the Jeppesen Terminal Building located at the Airport.

2.29. TERMINAL COMPLEX

"Terminal Complex" shall mean collectively the Terminal and the Concourses located at the Airport as they are defined herein.

2.30. VIBRANT FIRST-CLASS

"Vibrant First-Class" or "vibrant first-class" shall mean a manner or quality that is vigorous, lively vital and of the highest quality, which is to be determined by the City.

SECTION 3 – GRANT OF CONCESSION RIGHTS

3.01. CONCESSION RIGHTS GRANTED

Rights Granted. Concessionaire agrees that it is obligated to take possession of the Concession Space on the later of the Target Possession Date stated on the Summary Page or on the date included in any written correspondence from the City notifying Concessionaire that the Concession Space will be ready for use and occupancy by the Concessionaire, which date shall be documented in **Exhibit D**. Accordingly, as of the Possession Date, the City hereby grants to Concessionaire the right and obligation to occupy, construct upon, improve and use the Concession Space, consistent with the City's vision, Concessionaire's Proposal and subject to all of the terms, conditions, covenants and provisions of this Agreement.

Construction Obligation. Concessionaire shall have the right and obligation to construct improvements upon the Concession Space in accordance with plans and a Construction Schedule approved, in writing, in advance by the Manager's authorized representative. Concessionaire's construction obligations are set forth in more detail in Section 6.

Delay in Delivery. If for any reason the City cannot deliver possession of the Concession Space to the Concessionaire on the Target Possession Date, the City shall not be subject to any liability therefor. Such inability to deliver shall not affect the validity of the Agreement or the obligations of the Concessionaire hereunder or extend the Expiration Date. If for any reason the City is unable to deliver possession of the Concession Space to the Concessionaire within twelve (12) months after the Target Possession Date, then the Manager, in the Manager's sole and absolute discretion, shall have the option at any time thereafter to notify the Concessionaire in writing of the City's intent to terminate the Agreement in which event the Agreement shall terminate on the date stated in said notice and both the City and the Concessionaire shall be released from any liability or obligation under the Agreement. If for any reason the City has not terminated this Agreement or delivered possession of the Concession Space to the Concessionaire within eighteen (18) months after the Target Possession Date, then Concessionaire, at any time thereafter, may notify the Manager in writing of the Concessionaire's intent to terminate the Agreement after a date that is sixty (60) days from the date of the city's receipt of the written notice unless the City delivers possession of the Concession Space within that sixty (60) day period, in which case this Agreement shall remain in full force and effect. If the City has not delivered possession of the Concession Space to the Concessionaire within the sixty (60) day notice period, this Agreement shall terminate at the close of business on the sixtieth (60th) day and both the City and the Concessionaire shall be released from any liability or obligation under the Agreement.

3.02. USE OF CONCESSION SPACE

Permitted Use. Concessionaire may use the Concession Space only for the Permitted Use described on the Summary Page and for no other purpose. Concessionaire shall have a non-exclusive right to operate a food and beverage concession in the Concession Space shown on **Exhibit A**, and sell the food and beverage items described on the Summary Page and on the Approved Menu or as otherwise approved by the City. Concessionaire shall conduct only those operations and sell only approved food and beverage items under this Agreement. Concessionaire covenants and agrees to operate its Concession in strict conformity with the

Permitted Use, **Exhibit E** and any written authorization given to Concessionaire by the Manager or the Manager's authorized representative.

Express Restrictions. Unless otherwise authorized in writing by the Manager, Concessionaire shall not offer for sale at the Airport items expressly restricted on the Summary Page; nor shall Concessionaire offer for sale any food, beverage, merchandise and/or services or engage in any activity not specifically provided for under the terms of this Agreement.

Trade Name. Without limiting the generality of this Section 3 or any requirements set forth in this Agreement, Concessionaire shall not operate under any trade name or brand, other than a trade name registered in Colorado and brand(s) specifically provided for under the terms of this Agreement or otherwise authorized by the City.

No Solicitation or Displays outside the Concession Space. In no event will Concessionaire engage in any activity on the Airport outside of the Concession Space for the recruitment, solicitation or conduct of business nor shall Concessionaire place, install, maintain or use any racks, stands or other display of merchandise, trade fixtures or furnishings in or upon any areas located outside the Concession Space, regardless of whether such areas are adjacent to the Concession Space without written approval of the Manager or the authorized representative of the Manager.

Brands are Material. Concessionaire acknowledges that the use of brand, branded items or branded concepts is of critical importance to meeting the City's purpose for its concession program at Denver International Airport and therefore any Brand that Concessionaire is authorized to operate at Denver International Airport is a material part of the consideration to the City for this Agreement and may not be unilaterally discontinued or changed by Concessionaire.

License or Franchise Agreement. If the Brand that Concessionaire is authorized to operate from the Concession Space, in accordance with the terms of this Agreement, is not owned or controlled outright by Concessionaire but granted through a separate license or franchise agreement, then upon execution of this Agreement, Concessionaire shall provide to the City a copy marked "confidential, commercial information" of the license or franchise agreement or provide other documentation satisfactory to the City that demonstrates that Concessionaire has in fact entered into such a license or franchise agreement and that the license or franchise agreement provides the management and quality controls associated with the brand Concessionaire presented in its proposal. The parties agree that Concessionaire may redact confidential financial information from the copy submitted to the City. Concessionaire must continuously abide by the terms of the license or franchise agreement and maintain the license or franchise agreement in good standing throughout the Term (or any extended term) of this Agreement. Concessionaire hereby represents that there is nothing contained in the license or franchise agreement, which would prevent it from fully performing this Agreement and agrees that, in the event of a conflict between this Agreement and any such franchise or license agreement, the terms and conditions of this Agreement shall control. If Concessionaire fails to provide such documentation within thirty (30) days after execution of this Agreement, the City may terminate this Agreement by written notice to the Concessionaire in which event the Agreement shall terminate on the date stated in said notice and both the City and the Concessionaire shall be released from any liability or obligation under the Agreement.

3.03. RIGHTS NOT EXCLUSIVE

The City reserves the right to allow others to conduct operations and/or sell goods or services in other locations at the Airport that are the same, similar, or even identical to those described on the Summary Page. Concessionaire understands and agrees that its right to conduct operations and/or sell any goods or services at the Airport is not exclusive and that the use of the property subject to this Agreement is restricted by all applicable rules, regulations, statutes, or ordinances promulgated by any federal, state, or municipality having jurisdiction over the Airport.

3.04. MEANS OF ACCESS

Non-Exclusive Access. Concessionaire, its agents, invitees, guests, employees, contractors and suppliers have a non-exclusive right of ingress to and egress from the Concession Space by a means of access located outside the boundaries of such space as specified by City. Such access shall, without exception, be in common with such other persons (including, at the option of the City, the general public) as the City may authorize or permit, and the City may at any time close, relocate, reconstruct or modify such means of access, provided that a reasonably convenient and adequate means of ingress and egress is available for the same purpose.

Subject to Security. This right of access is subject to the security requirements of the Section herein entitled *Security*. Moreover, without exception, nothing in this Agreement shall be construed to prevent the City from charging the operators of vehicles carrying passengers and property a fee for the privilege of entering upon the Airport or using the roadways in or on the Airport, or soliciting passengers upon the Airport, or otherwise operating on the Airport; and City reserves the right to make such charges provided that they do not discriminate unreasonably against the operators of vehicles used for carrying officers, employees, passengers or property of Concessionaire.

3.05. CITY'S RIGHT OF INSPECTION; ACCESS

The City, its agents and employees, retain at all times during the Term of this Agreement, the full right of entry in and to the Concession Space for any purpose necessary, incidental to or in connection with its obligations hereunder, in the exercise of its governmental functions, or for the purpose of making any inspection it deems necessary, with or without advance notice, without liability, and without in any manner affecting Concessionaire's obligations under this Agreement. Without limiting the foregoing, such entry may be made to make such repairs, alterations, improvements, or additions as the City is required to make or authorized to make under this Agreement, to determine whether Concessionaire has complied with the terms and conditions of this Agreement, to cure any breach that remains uncured by Concessionaire after reasonable notice and opportunity to cure have been given to Concessionaire. During the last six (6) months of the Term (or any extended term) of this Agreement, the City may show the Concession Space to prospective tenants. In addition, during any emergency, the City, or its agents, may enter the Concession Space forcibly, if necessary. Nothing herein contained, however, shall be deemed to impose upon the City any obligation, responsibility or liability whatsoever, for any care, maintenance or repair, except as otherwise expressly provided for in this Agreement. No such reasonable entry by or on behalf of the City upon the Concession Space shall constitute or cause a termination of this Agreement nor shall such entry be deemed to constitute an interference with the use thereof by the Concessionaire.

SECTION 4 – TERM

4.01. TERM

This Agreement shall commence and become fully effective and binding upon the Parties as of the Effective Date stated on the Summary Page. "Term" as used herein shall mean the date commencing upon the Possession Date and expiring upon the Expiration Date, unless this Agreement is sooner terminated pursuant to the provisions of this Agreement or by law. Except for any changes to the Term included in any future amendment negotiated by the Parties, if the Required Opening Date changes pursuant to Section 6.12, the Expiration Date necessarily changes to provide the full amount of Term stated on the Summary Page and the changed dates shall be documented in *Exhibit D*. Each of these actions may be taken without the requirement of a formal amendment to this Agreement.

4.02. SURRENDER OF CONCESSION SPACE

Standard for Surrender. Upon the expiration or earlier termination of this Agreement or on the date specified in any demand for possession by City after any default by Concessionaire, Concessionaire must have fully performed all of its obligations under this Agreement. Concessionaire covenants and agrees to surrender possession of the Concession Space and all Improvements to City in broom clean condition and good state of repair, ordinary wear and tear excepted. Ordinary wear and tear shall not include deterioration that could have been prevented by proper maintenance practices, or by Concessionaire performing all of Concessionaire's obligations under this Agreement. Concessionaire covenants and agrees to cooperate with the City's Termination procedures described in Section 6.16.

4.03. HOLDING OVER

Holding Over. If Concessionaire holds over after the Expiration Date, any extension thereof, or earlier termination of this Agreement as herein provided, and the City and Concessionaire have not otherwise agreed, in a written amendment, to the terms and provisions of such holding over, thereafter Concessionaire's occupancy shall be deemed by the City to be either a month-to-month holdover tenant, or a tenant at sufferance, at a monthly rental, payable in advance, equal to 150% of the monthly Rent provided for in Section 5 of this Agreement ("holdover fee"), and Concessionaire shall otherwise remain bound by all terms, conditions, covenants, and agreements hereof. The holdover fee will be calculated by multiplying the Rent amount due each month by 1.5.

Tenant at Sufferance. In the event that the City deems Concessionaire a tenant at sufferance, all of the provisions of the previous sentence shall apply and the City will notify Concessionaire, in writing, that Concessionaire is a tenant at sufferance. Thereafter, the City may take immediate action to evict Concessionaire without further notice and may otherwise exercise any other rights and remedies available to it at law or in equity.

Month -to -Month Tenancy. If Concessionaire is deemed to be a holdover tenant, Concessionaire and the City agree that: (a) the tenancy shall be month-to-month and may be terminated at any time by thirty (30) days prior written notice from either Party to the other; and (b) the MAG shall continue to adjust annually, using the same formula for MAG adjustment as provided in Section 5.

Holdover Fee Waiver. Upon expiration of this Agreement, and in the Manager's sole discretion, the holdover fee may be waived in writing to allow Concessionaire to holdover at 100% of the monthly Rent provided for in Section 5 of this Agreement.

No Right to Holdover. Nothing herein shall be construed to give Concessionaire the right to hold over at any time, and the City (after expiration or termination of this Agreement, as the case may be), may exercise any and all remedies at law or in equity to recover possession of the Concession Space, as well as any damages incurred by City on account of such holding over.

SECTION 5 – RENT

5.01. RENT

Rent Covenant. Concessionaire covenants and agrees, in advance, without setoff, deduction, prior notice or abatement (except in Sections 12.01 and 14.09, where abatement may expressly be permitted), to pay City as Rent for the rights and privileges herein granted by City the greater of (a) a sum equal to Concessionaire's Gross Revenues, as herein defined times the percentage rate shown on the Summary Page for the volume and type of sales, derived by the Concessionaire from its operations under this Agreement ("Percentage Rent"), or (b) the Minimum Annual Guaranteed Rent ("MAG"), stated on the Summary Page, which may be annually adjusted as provided below, and in addition thereto, Additional Rent pursuant to Section 5.03. For purposes of applying the correct percentage rate, the volume for each type of sales indicated on the Summary Page resets to zero on January 1st of each year.

Rent Commencement. Said obligation to pay Rent shall commence upon the Rent Commencement Date stated on the Summary Page and shall continue through the Term (or any extended term) hereof, as well as any holding over period.

Minimum Annual Guaranteed Rent. The MAG for the first year will be the amount stated on the Summary Page. The MAG is an annual obligation and shall be paid monthly in twelve equal installments ("MMG"). The first MMG payment shall be due and payable on the Rent Commencement Date and thereafter the MMG shall be paid on the first day of each month through the Term (or any extended term) hereof, as well as any holding over period. After the first full year and for each subsequent year of this Agreement, the MAG will be adjusted annually on a common annual date to be established by the City to an amount equal to (i) 85% of the Rent payable to the City for the prior year as computed under this Section 5 (excluding any Additional Rent) or (ii) the first year MAG initially stated on the Summary Page, whichever is greater. Notwithstanding the foregoing, the MAG will never be less than the first year MAG initially stated on the Summary Page. The City reserves the right to establish a common annual MAG adjustment date for all Concessionaires.

5.02. GROSS REVENUES

All Revenue. As used herein, "Gross Revenues" shall mean all revenue generated by Concessionaire from doing business under this Agreement including, but not limited to, billings and receipts at the point of sale from sales of all items sold, whether for retail or wholesale, and the charges for all services performed by Concessionaire or any other person or entity in, at, or from the Concession Space, regardless of place or time of actual payment or receipt of

merchandise, whether for cash, credit, gift certificates, memberships, service contract, or otherwise, regardless of whether any party other than Concessionaire is providing or operating equipment or services involved in the transaction or billing or receiving revenue from such transaction, without reservation or deduction for uncollected amounts, credit card fees or charges, or collection costs, including, but not limited to: (a) all sales or services occurring on the Concession Space or within the Airport, including all orders that originate in, at or from the Concession Space, regardless of where delivery or performance is made; (b) orders that are made to and/or filled from the Concession Space pursuant to mail, telephone, fax, catalog, internet, or otherwise received, filled, or distributed from the Concession Space, even if performed at cost or related to a service or management fee associated with providing food, beverages, merchandise and/or services for an airline's preferred passenger club/lounge (c) any income resulting from transactions originating in, at, or from the Concession Space or within the Airport including but not limited to promotional or advertising income received by or paid to Concessionaire in exchange for displays, promotions, advertising or other business transacted at the Concession Space, (d) deposits not refunded to customers; (e) discounts not excluded hereunder, and (f) insurance proceeds received due to loss of gross earnings under business interruption coverage.

Excluded from Gross Revenues. When properly recorded and accounted for, a reduction from Gross Revenues shall be allowed for: (i) bona fide returns for credit, (ii) refunds to customers, but only to the extent the original sale to that customer was included in Gross Revenues; (iii) sales of fixtures, machinery and equipment after use in Concessionaire's business in the Concession Space; (iv) sales, excise, or similar taxes imposed by a governmental entity and collected from customers and then directly paid by Concessionaire to the government entity; sales taxes collected for remittance to the State or City and federal excise taxes collected, which must be separately stated, collected from the customer and remitted to the federal government by the Concessionaire; (v) tips and gratuities; (vi) advertised discounts, discounts approved in writing by the City and discounts given to employees displaying an Airport issued badge when Concessionaire documents the badge number on the receipt, and (vii) shipping and delivery charges if provided at cost and separately stated on customer invoices. There shall not be allowed from Gross Revenues any reduction for bad debts, loss from theft or any deduction except as described above.

Recording of Gross Revenues. To record all sales generated in, at, or from the Concession Space, Concessionaire shall use a cash register and/or other point of sale system (collectively, "POS") acceptable to the City, which is capable of producing duplicate sales slips, or printouts on which each sale is identified, itemized and recorded.

5.03. MONTHLY REVENUE STATEMENTS AND PAYMENTS

MAG Payment. The MAG, as adjusted pursuant to Section 5.01, shall be paid monthly in equal installments (the "Minimum Monthly Guarantee" or "MMG"). The first MMG payment shall be due and payable by Concessionaire to the City without demand on the Rent Commencement Date and thereafter the MMG shall be paid on the first day of each calendar month through the Term (or any extended term) hereof. The MMG for a partial month during the Term of this Agreement shall be prorated on a per diem basis.

Revenue Statements. Each month, Concessionaire shall furnish a true and accurate verified statement of Concessionaire's Gross Revenues for the preceding month ("Revenue

Statement"). Monthly Revenue Statements are due by the 10th day of the second month following the first MMG payment and then by the 10th day of each succeeding month of the Term (or any extended term or holding over period). Monthly Revenue Statements are to be submitted to the Airport's Finance Section and the Concessions Management Section by mail at the address shown below in Section 5.06. Monthly Revenue Statements shall be submitted using either a form provided to the Concessionaire, an example of which is attached hereto as **Exhibit L, Concession Monthly Revenue Report**, or one approved by the Manager's authorized representative and shall indicate where noted on the form Concessionaire's calculation of Rent due to the City. At any time upon 30 days advance written notice to Concessionaire, the Manager's authorized representative may require Concessionaire to submit its monthly Revenue Statements in electronic form, may change the timing of the submittal of the monthly Revenue Statements, or may otherwise modify the form of the monthly Revenue Statement and Concessionaire agrees to use the new form commencing with the report for the month following receipt of the new format. In changing the required reporting format, the City may require and Concessionaire agrees to report Gross Revenues broken out by, including but not limited to, brand or concept, by product or by product line, food, beverage, alcoholic beverage or by item listed on the Summary Page, **Exhibit E** or otherwise approved by the Manager for sale in the Concession Space. The Parties agree that these changes may be made without the formality of amendment this Agreement.

Percentage Rent Payment. In the event that the Percentage Rent based on Concessionaire's Gross Revenues derived from its operations for the preceding month exceeds the MMG payment for that month, Concessionaire shall pay to the City an amount equal to such excess on or before the 10th day of the succeeding month. Passenger traffic varies so it is possible to pay the MMG in one month and the Percentage Fee in another month. Concessionaire understands that no adjustments or credits will be refunded at the end of each month. Percentage Rent is a monthly obligation, which will not be annualized at the end of each year to result in a Rent credit for any month.

Revenue Statements to be Certified. Revenue Statements shall be signed by the chief financial or executive officer or other officer of Concessionaire charged with such responsibility (the "Certifying Officer") certifying that to the best knowledge of the officer submitting the Statement, the Gross Revenue reported and the Rent paid by Concessionaire for the preceding month, was correct and properly calculated in accordance with the terms of this Agreement.

Joint Marketing Fund Payment Due. With its monthly Revenue Statement, Concessionaire shall also calculate and pay to the City a monthly Marketing Assessment as provided in Section 13.01.

Additional Rent. All amounts required to be paid by Concessionaire under this Agreement, other than the MAG and Percentage Rent, shall be deemed "Additional Rent" (whether or not so designated herein), including but not limited to the Joint Marketing Fund payment, Interim Rent, utilities fees, late or delinquent fees, accrued interest, liquidated damages and any other fees or charges payable under this Agreement. Concessionaire shall pay the Additional Rent in the manner and at the place provided in this Agreement. If such amounts or charges are not paid at the time and in the manner as provided in this Agreement, they shall nevertheless be collectible as Additional Rent with the next installment of Rent thereafter falling due, but nothing herein contained shall be deemed to suspend or delay the payment of any amount of money or charge at the time the same becomes due and payable hereunder or to limit any other remedy of the

City. All amounts of MAG, Percentage Rent and Additional Rent (also collectively referred to in this Agreement as "Rent") payable in a given month shall be deemed to comprise a single rental obligation of Concessionaire to City.

Performance Surety may be Drawn. If the City has not received the monthly Revenue Statement on the date due, the City reserves the right, in addition to all of its other rights as stated herein, to immediately thereafter invoice Percentage Rent to Concessionaire based on the City's estimate of Concessionaire's Gross Revenues and, after notice, to draw on the Performance Surety, based on the City's estimate of what is due. Any such draw against the Performance Surety by the City shall not release Concessionaire from the obligation of providing the actual Monthly Revenue Statement.

Concessionaire's Payment Obligations. Concessionaire covenants to pay all Rent and charges under this Agreement independent of any obligation of the City. No breach of this Agreement by the City shall relieve Concessionaire of its obligation and duty to pay all such Rent and charges when due under the terms of this Section 5.

5.04. TITLE TO CITY'S COMPENSATION

Immediately upon Concessionaire's receipt of monies from doing business under this Agreement, including the sale of food, beverages, merchandise and/or services that it is authorized to sell under the terms of this Agreement, the percentages of said monies belonging to City shall immediately vest in and become the property of the City. Concessionaire shall be responsible as trustee for said monies until the same are delivered to City.

5.05. INTEREST ON PAST DUE AMOUNTS

Any payments not made to City when due shall accrue interest at the Past Due Interest Rate, as herein defined.

5.06. PLACE AND MANNER OF PAYMENTS

All sums payable to City hereunder shall be made payable to "Airport Revenue Fund" and paid without notice at the following address:

Airport Revenue Fund
Denver International Airport
P.O. Box 492065
Denver, CO 80249-2065

or, at such other place as the Manager's authorized representative may hereafter designate by notice in writing to Concessionaire. All sums shall be made in legal tender of the United States. Any check given to the City shall be received by it subject to collection, and Concessionaire agrees to pay any charges, fees or costs incurred by the City for such collection, including reasonable attorney's fees, costs and expenses.

5.07. APPLICATION OF PAYMENTS

The City is entitled to accept, receive and cash, or deposit, any payment made by Concessionaire for any reason or purpose or in any amount whatsoever, and apply the same, in

the City's sole option, to any obligation of Concessionaire. Such payment or application shall not constitute payment of any amount owed, except that to which the City has applied the payment. No designation of any payment by Concessionaire for application to a specific portion of Concessionaire's financial obligations hereunder shall be binding upon the City. No endorsements or statement on any check or any letter accompanying any check or payment as compensation or other charges shall be deemed an accord and satisfaction or otherwise recognized for any purpose whatsoever. The acceptance of any such check, payment or partial payment, shall be without prejudice to the City's right to recover the balance of any and all compensation or other charges due from Concessionaire to the City and the City's right to pursue any other remedy provided in this Agreement or at law or in equity.

5.08. BOOKS OF ACCOUNT AND AUDITING

Revenue Statement Required Annually. Not later than February 28 of each and every year during the Term (or any extended term) hereof, Concessionaire shall furnish to City a true and accurate statement of the total of all Gross Revenues for the preceding calendar year listing the authorized deductions or exclusions in computing the amount of such Gross Revenues and including a breakdown of Gross Revenues on a month-by-month basis. Such statement shall be furnished for every calendar year in which business was transacted under this Agreement during the whole or any part of the year.

Form of the Statement. Statements of annual Gross Revenues shall be submitted in a form acceptable to the Manager's Authorized Representative, and shall contain a complete, itemized statement of Concessionaire's: (a) annual total Gross Revenues broken out monthly, as shown on the books and records of Concessionaire, with detail used to compute any Percentage Rents during the period covered by the Annual Statement; (b) the total Rent due under each category of sales reported on the Revenue Statements; and (c) the total Rent paid.

Certified Annual Statements. Except for the option described below, statements of annual Gross Revenues are to be prepared and certified by an independent certified public accountant ("CPA"), who has audited the Gross Revenues in accordance with generally accepted accounting principles for special reports applying certain estimates and informed judgments, as required, and in substantial conformity with the form appended hereto as **Exhibit I, Independent Auditor's Report**. These statements are referred to in this Agreement as "Certified Annual Statements."

The Annual / Bi-Annual Statement Option. In any year of the Term (or any extended term) that a Certified Annual Statement is not required by other provisions of this Agreement, Concessionaire may elect to submit an "Annual Statement" for one year, followed by a "Bi-Annual Statement" for the next year. An "Annual Statement" is a statement of annual Gross Revenues for the preceding calendar year that is prepared by Concessionaire's Certifying Officer. The Annual Statement is due February 28th and Concessionaire's officer must certify that the Gross Revenue reported and Rent paid by Concessionaire during the preceding year was properly calculated and reported, that the monthly Revenue Statements were free of material misstatement and that payment was made in accordance with the terms of this Agreement. A "Bi-Annual Statement" is a CPA prepared statement of annual Gross Revenues for the preceding calendar year, which is accompanied by a letter from the CPA in substantial conformity with the form applying agreed upon procedures appended hereto as **Exhibit J, Independent Accountant's Report on Applying Agreed-Upon Procedures**. The Bi-Annual

Statement is due February 28th of the year following submission of an Annual Statement. If Concessionaire elects this option, the City agrees to accept the Annual and Bi-Annual Statements in lieu of Certified Annual Statements for the period covered by the Annual and Bi-Annual Statements. Concessionaire may submit Certified Annual Statements in any year of the Term (or any extension of the term).

Late Statements. Any annually required statement furnished to the City late, meaning submitted after the date such statement is due, shall be a Certified Annual Statement. In such case the Certified Annual Statement shall be submitted to the City no later than 90 days from the date the late statement was due, unless upon good cause shown by Concessionaire, the due date of the annually required statement is extended, in writing for no more than 90 days, by the Manager's authorized representative. .

Manager's Discretion. The above requirements for annually furnishing to the City true and accurate statements of Gross Revenues may be modified by the Manager at any time during the Term (or any extended term) of this Agreement if, in the Manager's sole and absolute discretion, such modification is in the best interest of the City.

Bookkeeping System. Concessionaire agrees to establish and maintain an accounting system of bookkeeping in conformity with generally accepted accounting principles and satisfactory to the City's Auditor. Such system shall be kept in a manner as to allow each location of the Concessionaire's operations hereunder to be distinguished from all other locations or operations of Concessionaire.

Financial Accountability. Concessionaire shall keep and make available upon request true and complete records and accounts of all Gross Revenues and business transacted, including daily bank deposits. Concessionaire shall keep and preserve for at least three (3) years after expiration or termination of this Agreement, or until sooner audited by the City, all sales slips, cash register tapes, sales books, bank books or duplicate deposit slips, and all other evidence of Gross Revenues and business transacted for such period.

Audit of Records. The City's Auditor, the Manager, the Federal Aviation Administration, the Comptroller General of the United States and any of their duly authorized representatives, shall each have access within the Denver metropolitan area to any books, documents, papers and records of the Concessionaire, which are directly pertinent to this Agreement for the purpose of making audit, examination, excerpts and transcriptions. Each shall have the right at any time to inspect, copy, examine or audit all of the books of account, bank statements, documents, records, returns, papers and files of Concessionaire relating to the Gross Revenues and business transacted to verify compliance with this Agreement.

Audit Request. Concessionaire, upon the written request, as set forth in the preceding paragraph, of a duly authorized representative, shall make all such documents available for examination within the Denver metropolitan area; or shall pay in full, in advance, travel and related expenses of a duly authorized representative to travel to any location outside the Denver area for such examination. Following the travel, expenses shall be reconciled, and any difference between the advance payment and the actual travel and related expenses shall be paid by or refunded to Concessionaire, as appropriate. Such documents shall be available to the duly authorized representative within 14 calendar days of the date of the written request.

Concessionaire to Provide Publicly Available Audits. If Concessionaire is a publicly-traded company, if Concessionaire is audited by anyone other than the duly authorized representative of any entity authorized to conduct audits pursuant to this Section 5.08, and if a report of the audit is publicly available, Concessionaire agrees to provide a copy of any such audit report to the City upon request.

Concessionaire to pay for Revenue Audits. At its discretion, the City may use its own staff to perform audits of Concessionaire's books and records or the City may employ an outside party or firm to audit on behalf of the City the books and records of the Concessionaire pursuant to this Section 5.08. If, after a risk analysis of Concessionaire's operations at the Airport, the City employs an outside party or firm to conduct a revenue audit of sufficient scope to ensure compliance with this Agreement regarding the reporting of Gross Revenues and the resulting payment of Rent, Concessionaire agrees to pay the reasonable expense of either (i) one such audit if the Term is five years or less, or (ii) two such audits, if the Term of this Agreement, including any extension of the Term, is greater than five years.

Understated Revenues. The foregoing requirement of Concessionaire to pay for certain audits notwithstanding, if, after any audit by any duly authorized representative, including any outside party or firm engaged by the City to conduct audits on its behalf, it is determined for any year that the Gross Revenues and business transacted shown by Concessionaire's statement for such year were understated, Concessionaire forthwith shall pay the amount of the deficiency plus interest at the Past Due Interest Rate. If an audit reveals that Concessionaire has understated its Gross Revenues by more than 1% in two of any six months of an audited period of no more than twelve months prior to the date of the audit, the entire expense of the audit shall be paid for by Concessionaire; Concessionaire shall pay the Past Due Amount to City, plus interest at the Past Due Interest Rate, plus the cost of the audit all within 30 calendar days of the City's invoice. In addition, for the most current year in which gross revenues were understated, Concessionaire shall have a CPA prepare and submit a Certified Annual Statement to the City.

Audit Delay. The Parties agree that, after execution of this Agreement, any delay in furnishing such records to the duly authorized representative requesting such records will cause damages to the City, which the Parties agree are liquidated in the amount of \$350.00 per day for each day the records are unavailable beyond fourteen (14) days following the date of the City's request. Liquidated damages will continue to accrue until the records become available or other arrangements to produce documents for examination satisfactory to the duly authorized representative are made.

Time for Performing an Audit. Books and records shall be kept for a period of three (3) years even if this period extends after expiration or termination of this Agreement. The City's right to perform an audit shall expire three (3) years after expiration or termination of this Agreement.

City's Sales Taxes. Concessionaire agrees that the Manager, the Auditor and their authorized representatives, may inspect any documents, returns, data or reports filed pursuant to Chapter 53 of the Denver Revised Municipal Code by Concessionaire with the City's Manager of Revenue and any related reports, documents, data or other information generated by the City's Manager of Revenue or employees under the control of such Manager of Revenue in connection with any investigation or audit of Concessionaire by the City's Department of Revenue. Concessionaire authorizes and permits the inspection of such documents, data,

returns, reports and information by the Manager, the Auditor and their authorized representatives, and, further, waives any claim of confidentiality that it may have in connection with such inspection of documents, returns, data, reports and information.

5.09. RECOVERY OF CITY EXPENSE TO FULFILL CONCESSIONAIRE'S OBLIGATIONS

City's Right to Cure. If Concessionaire fails to perform any of Concessionaire's obligations under this Agreement, the City, without waiving any of its remedies pursuant to this Agreement, may, but shall not be obligated to, perform the same for the account of, and at the expense of Concessionaire, without notice in a case of emergency, and in any other cases, only if such failure continues after the expiration of thirty (30) days from the date the City gives Concessionaire written notice of the failure specifying the details. The City may elect to perform work at the City's standard rates or have work performed by a contractor hired by the City. The City shall not be liable to Concessionaire for any claim for damages resulting from such remedial action by the City.

Concessionaire to Reimburse City. If the City has paid any sum or sums or has incurred any obligations or expense for which the Concessionaire has agreed to pay or reimburse the City, or if the City is required or elects to pay any sum or sums or insure any obligations or expense (a) by reason of failure, neglect, or refusal of the Concessionaire to perform or fulfill any one or more of the conditions, covenants, or agreements contained in this Agreement beyond any applicable notice or cure period; or (b) as a result of an act of omission of the Concessionaire contrary to the conditions, covenants, and agreements contained in this Agreement for which City has provided Concessionaire written notice and an opportunity to cure as provided herein, then, within five (5) business days after written notice thereof by the City, the Concessionaire agrees to pay to the City the sum or sums so paid or the expenses so incurred, including all interest, costs, damages, and penalties, plus a twenty percent (20%) administrative fee, and each and every part of the same shall be and become Additional Rent, recoverable by the City in the same manner and with like remedies as if it were originally a part of the Rent as set forth herein.

Evidence of Reasonable Expense. For all purposes under this Section 5.09, and in any suit, action, or proceeding of any kind between the Parties hereto, any receipt showing the payment of any sum or sums by the City for any work done or material furnished shall be prima facie evidence against the Concessionaire that the amount of such payment was necessary and reasonable. In the event the City sues to collect any delinquent payments due it by the Concessionaire, the City shall be entitled to recover all court costs and its reasonable attorney's fees. Should the City elect to use its own operating and maintenance staff in making any repairs, replacements, and/or alterations and to charge the Concessionaire with the cost of same, any timesheet of any employee of the City showing hour of labor or work allocated to any such repair, replacement, and/or alteration, or any stock requisition of the City showing the issuance of materials for use in the performance thereof, shall be prima facie evidence against the Concessionaire that the amount of such charge was necessary and reasonable.

5.10. REMEDIES NON-EXCLUSIVE

The remedies provided in this Section 5 are in addition to all other rights and remedies that the City may have for a breach or violation of this Agreement. Nothing in this Section shall be deemed to be a waiver by the City of any breach or violation, nor shall it be deemed to stop the

City from terminating this Agreement or from asserting any other of its other rights or remedies under this Agreement, or at law or in equity. Nothing contained herein shall be construed to require the City to accept delinquent Rent, or delinquent Additional Rent. Acceptance of full or partial payment of delinquent Rent, or delinquent Additional Rent, shall not constitute a waiver of any of the City's other rights and remedies stated in Section 11.

5.11. REESTABLISHMENT OF RENTALS, FEES AND CHARGES

City may reestablish Rentals, Rates, Fees and Charges. The City, through the Manager, may from time to time, at intervals of not more than five (5) years, at the Manager's sole discretion, and subject to the requirements of any outstanding bond ordinance pertaining to the Airport, reestablish the rentals, rates, fees and charges provided for herein. The City agrees that such reestablished schedule of rentals, rates, fees and charges shall be reasonable in relation to the cost of providing, operating and maintaining property, services and facilities of the airport system.

Concessionaire may Cancel and Terminate Agreement. If the Manager proposes any change in the schedule of rentals, rates, fees and charges, the City will give notice thereof to Concessionaire not less than 90 days before the same is to become effective. Should the proposed rentals, rates, fees and charges result in an increase of more than 5% in the dollar amount of compensation paid by Concessionaire for the prior calendar year, then Concessionaire may decline to pay compensation at the new rate(s). Concessionaire shall promptly advise the Manager (but in no event less than 60 days prior to the proposed effective date of such schedule of rentals, rates, fees and charges) of its intention to cancel and terminate this Agreement. Upon such notice of intent to cancel and terminate, Concessionaire shall surrender the Concession Space upon a date specified by the Manager. Should Concessionaire fail to give such notice of cancellation and termination, then it shall be deemed to have accepted the new rate(s) of compensation as promulgated by the Manager.

No Waiver. No failure by the City to reestablish the rentals, rates, fees and charges at a five (5) year interval date shall constitute a waiver of the City's right to reestablish the rentals, rates, fees and charges at any time thereafter.

SECTION 6 – CONSTRUCTION RESPONSIBILITIES OF CONCESSIONAIRE

6.01. "AS IS" CONDITION OF CONCESSION SPACE

Concessionaire accepts the Concession Space in "as is" and "where is" condition with absolutely no warranties as to condition or suitability for use being given by the City. Concessionaire is required to demolish completely and remodel the Concession Space and all Improvements made to the Concession Space, unless otherwise specified herein, shall be made and maintained by Concessionaire, at Concessionaire's sole cost and expense.

6.02. TIME TO COMPLETE DESIGN AND CONSTRUCTION

Time is of the Essence. The Parties agree that time is of the essence in the performance of Concessionaire's obligations throughout the Term (or any extended term) of this Agreement.

Design and Construction Completion Deadline. Concessionaire, at its own cost and expense, shall complete its design, obtain building permits and complete construction or installation of the initial Improvements, move into and occupy the constructed Concession Space no later than the Design and Construction Completion Deadline stated on the Construction Summary Page. Such period may be extended by the Manager or the Manager's authorized representative, in writing, if completion of the design or construction or installation of the initial Improvements was delayed by fault of the Airport, in which case, The Parties will proceed to document the changed dates on **Exhibit D**, as provided in Section 6.12. The Concessionaire understands and agrees to start the design process, as outlined in Sections 6.03 and 6.04, immediately upon execution of this Agreement.

6.03. APPROVAL OF PLANS AND SPECIFICATIONS FOR NEW SPACE

Conceptual Plans. As soon as practicable but no later than 30 days after execution of this Agreement, Concessionaire shall attend a pre-design meeting with the Airport's concessions management team and thereafter, prepare and submit for City review, conceptual plans and specifications (collectively "Conceptual Plans") and a proposed design and construction progress and completion schedule ("Construction Schedule") for the construction of all proposed initial Improvements. Concessionaire's design(s) will be reviewed by the Airport's contractor for design review also known as the Airport's Retail Architect Consultant. The cost for this service is estimated to range from \$5,000 to \$10,000 depending on the amount of work required by the project. It is Concessionaire's obligation to reimburse the City within thirty (30) business days after City's demand an amount not to exceed \$10,000 for the City's actual costs related to the design review undertaken by the Airport's Retail Architect Consultant in connection with this Agreement.

Prompt Submission. Conceptual Plans shall show architectural design as well as planned furnishings, equipment and decorative effects as well as dimensioned floor plans, drawn to scale, dimensioned elevation views, drawn to scale, isometric color renderings, material sample boards, and additional plans, sections, details, etc. as necessary to completely and accurately convey the intent of the proposed submittal. Conceptual Plans must be submitted to the City promptly. Prior to submission of Conceptual Plans, Concessionaire should carefully review the DIA Design Standards and the DIA Tenant Development Guidelines, paying particular attention to the Sense of Place section of the Tenant Development Guidelines, which outline the process for preparing the Conceptual Plans and for working with the City in obtaining approval of Conceptual Plans.

Prompt Review. The City, including but not limited to the Airport's Engineering Division and the Airport's Design Review Committee, shall promptly review and comment on the Conceptual Plans. City approval shall extend to all design elements (e.g., materials, color selections) and all architectural and aesthetic matters. During this comment and review period, Concessionaire must be available to respond to the City in order to arrive at mutually acceptable plans for the Concession Space. Concessionaire will promptly submit necessary modifications and revisions thereof and the City agrees to act promptly upon receipt of such modifications and revisions and upon Concessionaire's requests for approval of Concessionaire's Conceptual Plans.

6.04. FINAL PLANS

Design Considerations. Once Conceptual Plans are approved, Concessionaire may move forward with the design for the Concession Space. The design shall include all tenant finish requirements including but not limited to lighting, power, plumbing, HVAC distribution from main air supply, HVAC controls for the tie in to the base building system, supplemental HVAC if needed, life safety systems, interior finishes, all furnishings, fixtures, trade fixtures, equipment, and signage necessary to operate in a first-class manner. Special attention must be given to the design of the HVAC and electrical systems. For a concept that creates odors, the mechanical system must be designed or configured to prevent the transmission of said odors to other portions of the Concourses or the Terminal. All plans and specifications, materials and color selections are subject to review and approval by the Manager's authorized representative.

Preparation of Final Plans. It is Concessionaire's responsibility to submit drawings for the City's approval prior to construction. Concessionaire shall prepare for approval by the City final plans and detailed specifications that incorporate the design intent approved by the City in the Conceptual Plans ("Final Plans"). Final Plans must be prepared by an architect or engineer licensed to practice in the State of Colorado.

Resubmission until Approved. The City reserves the right to reject any design concept or layout plan submitted and to require Concessionaire promptly to submit necessary modifications and revisions that address the City's concerns and resubmit Final Plans until they meet the City's approval. Concessionaire agrees to submit promptly necessary modifications and revisions thereof and the City agrees to act promptly upon receipt of such modifications and revisions and upon Concessionaire's requests for approval of Concessionaire's Final Plans. Once the Final Plans have been approved, in writing, by the City, all construction shall conform to the Final Plans, and no substantial changes or alterations shall be made in any plans or specifications at any time during this Agreement without the prior written approval of the City.

No Construction without Final Plans. As soon as practicable but no later than 10 days after approval by the City of Concessionaire's Final Plans, Concessionaire shall attend a pre-construction meeting with the Airport's Concession Tenant Facilities Manager. Tenant may not construct or install the initial Improvements as defined in Section 6.06 and **Exhibit X** without City approved Final Plans and a City issued Notice to Proceed ("NTP") as defined in Section 6.05.

6.05. NOTICE TO PROCEED

After Final Plans are approved and prior to the commencement of construction, Concessionaire shall submit necessary documents identified in the DIA Tenant Development Guidelines and **Exhibit X**, which outline the process for working with the City to obtain an NTP. In connection therewith, Concessionaire shall deliver to the Manager a payment bond that guarantees prompt and faithful payment of the construction contract by the Concessionaire directly to the contractor and shall ensure that Concessionaire's contractors deliver a construction performance and payment bond that guarantees prompt and faithful performance of the contract and prompt payment by Concessionaire's contractors to all persons supplying labor, materials, team hire, sustenance, provisions, provender, supplies, rental machinery, tools and equipment used directly or indirectly by the said contractor, subcontractor(s), and suppliers in the prosecution of the work provided for in said construction contract, which shall protect the City from any liability,

losses or damages arising from Concessionaire's construction activities occurring at the Airport. All bonds shall be issued by a surety company licensed to transact business in the State of Colorado and satisfactory to and approved by the City, and shall be in form and with conditions as provided by the City. In lieu of a construction bond, the Concessionaire may provide only such alternate forms of security as are permitted by the Manager, in such form and with conditions as the Manager requires.

6.06. CONSTRUCTION OF INITIAL IMPROVEMENTS

Concessionaire to Install Initial Improvements. Once an NTP is issued by the City, Concessionaire shall construct and install at Concessionaire's own expense, all initial Improvements necessary for the customary operation of Concessionaire's business, including, but not limited to, lighting, power, plumbing, HVAC distribution from main air supply, HVAC controls for the tie in to the base building system, supplemental HVAC if needed, life safety systems, interior finishes, all furnishings, fixtures, trade fixtures, equipment, signage, counters, display cabinets, interior partitions, lighting, fixtures, wall and ceiling finishes, flooring and floor coverings, and all other equipment and furnishings necessary to operate in a first-class manner.

Concessionaire to Supply Concessionaire's Equipment. Concessionaire shall supply all of Concessionaire's furniture, furnishings, trade fixtures, signage and equipment necessary to operate a first-class concession. All items not affixed to Airport property subject to this Agreement, including point of sale equipment, moveable furnishings, safes, racks, telephone equipment and non-affixed display fixtures, shall be deemed to be Concessionaire's Equipment as defined in Section 2.07. All of Concessionaire's Equipment must be of first-class quality, safe, attractive, in compliance with all applicable codes and the DIA Tenant Development Guidelines and may be installed only with the City's prior written approval. All of Concessionaire's Equipment and all Improvements that are permanently affixed to the Concession Space and cannot be removed without damage to the Concession Space shall be considered "Tenant Improvements." As used in this Agreement, "Tenant Improvements" shall mean affixed Improvements. All Improvements that are not Tenant Improvements are considered Concessionaire's Equipment.

6.07. CONSTRUCTION STANDARDS

All construction performed by Concessionaire, including construction and installation of all Improvements, shall conform in all material respects to the Final Plans, DIA Tenant Development Guidelines, applicable statutes, ordinances, building codes, fire codes, State and federal Occupational Safety and Health Act safety requirements, Airport Rules and Regulations, the City's tenant construction permit requirements, the requirements of ***Exhibit X, Provisions for Design and Construction of Improvements*** and the Americans with Disabilities Act ("ADA") requirements. Any approval given by the City shall not constitute a representation or warranty as to such conformity. Responsibility for conformity at all times shall remain with Concessionaire. Before beginning any construction work on the Concession Space, Concessionaire must obtain at Concessionaire's expense, an NTP, as described in the Tenant Development Guidelines.

6.08. REQUIRED MINIMUM INVESTMENT

Minimum Capital Investment Required. Concessionaire guarantees that it will make capital investments for said concession and shall construct the initial Improvements, furnish and equip the Concession Space at a minimum investment set forth on the Summary Page ("Required Minimum Investment"). The Required Minimum Investment shall not include financial costs, interest, inventory, pre-opening expenses or intra-company charges, but may include architectural and engineering fees not exceeding 15% of the total.

Minimum Capital Investment is Material. The Required Minimum Investment is a material part of the consideration to the City under this Agreement. Within 90 days after completion of construction Concessionaire shall file with the Manager lien releases for the above expenditures and a statement certified by its architect setting forth the total construction costs with appropriate detail itemizing design fees, original construction contract amount, total change orders, decorations, furnishings, fixtures, and equipment. At City's request, Concessionaire shall also submit copies of invoices supporting such costs. Non-receipted expenditures will not be credited. If the total amount of the Concessionaire's construction costs is less than the Required Minimum Investment, the difference between such total cost (as detailed by the certified receipts) and the Required Minimum Investment for renovating the Concession Space, shall be paid to City within 30 days after written notice from City to Concessionaire.

6.09. COORDINATION OF CONSTRUCTION

Periodic Design and Construction Meetings. Concessionaire shall cooperate with City and its planners, designers, architects, and engineers in the construction and installation of the Improvements on the Concession Space, and shall comply with all approved plans and the Building Code. Concessionaire agrees to meet with the City on a periodic basis, as requested by the Tenant Facilities Manager. The Airport Concessions Manager shall be copied on all design and construction meeting minutes.

Construction in Adjacent Areas. Concessionaire recognizes that during the Term (or any extended term) of this Agreement, construction may also occur in adjacent areas surrounding its Concession Space, and Concessionaire agrees to cooperate with and grant to other contractors access to Concessionaire's Concession Space when necessary to accommodate construction occurring in adjacent areas.

Work Subject to Inspection. All construction work, materials and installations involved in or incidental to the construction on the Concession Space shall be subject at all times to inspection and regulatory control by the City. The City shall at all times have the right of access to the Concession Space to monitor and inspect the construction, work, materials and installation of the Improvements to ensure that such Improvements, if any, conform in all respects to the Final Plans.

6.10. ENVIRONMENTAL REQUIREMENTS FOR CONSTRUCTION

In the performance of construction activities for the Improvements, Concessionaire is responsible for compliance and shall require its contractors to comply with all federal, state, and local environmental requirements including, without limitation the Environmental Requirements set forth on **Exhibit N, DIA Environmental Requirements**.

6.11. BUILDING PERMITS

In addition to approvals required by the Airport, Concessionaire and its contractor are solely responsible for applying for, obtaining, and paying for all required building permits, licenses and other required approvals, and are responsible for submitting plans and specifications to the City's Building Inspection Division for the necessary building permits.

6.12. COMPLETION OF CONSTRUCTION

Completion of Construction. Upon completion of construction of the initial Improvements Concessionaire shall deliver to City a copy of the Temporary Certificate of Occupancy ("TCO") and Certificate of Occupancy ("CO") for the entire (100%) Concession Space, if one is issued by the City Building Department. If a TCO or CO is not issued by the City Building Department, Concessionaire shall provide a copy of the final Permit Inspection Card indicating inspection and approval by the issuer of said permit. Concessionaire shall obtain the City's written permission to remove its construction wall and shall immediately thereafter Open for Business and document the Rent Commencement Date as provided in Section 2.25.

Delay in Opening. If Concessionaire has not Opened for Business, as provided in Section 2.22, by the Required Opening Date stated on the Summary Page, Concessionaire shall pay Interim Rent every month until construction is completed and the Concession Space is Opened for Business, at which time the Parties shall document the final Rent Commencement Date as provided in Section 2.25. Rent then shall be due and payable monthly as provided in Section 5.

Interim Rent. For each month due and payable, Interim Rent shall be the amount stated on the Summary Page, which consists of 1/12 of the annual sales (Gross Revenue) projected by Concessionaire in its Proposal and Pro Forma for Concessionaire's first year of operation. The amount of such Interim Rent, which will be prorated daily for any partial month, has been determined based upon numerous considerations including the fact that the City has foregone lost opportunity costs and expended money in reliance upon and based upon Concessionaire Opening for Business on the intended opening date as well as Concessionaire's Proposal and Pro Forma. Such Interim Rent shall be deemed to include Percentage Rent (as defined in Section 5.01) that might have been earned during the period of Concessionaire's failure to Open for Business.

Interim Rent Due on the Required Opening Date. The first Interim Rent payment is due on the Required Opening Date, but only if the store is not Open for Business on such date. If that date is other than the first day of the month, then the first Interim Rent payment shall be prorated for that month. Thereafter, Interim Rent payment is due on the first day of each calendar month until construction is completed and the Concession Space is Opened for Business.

Interim Rent as a Remedy. The Parties agree that it is and will be impracticable and extremely difficult to determine the actual damages suffered by the City by Concessionaire's delay in Opening for Business and therefore, in order to compensate the City for its loss Concessionaire agrees that it shall pay Interim Rent to the City for each month Concessionaire delays its initial Opening for Business beyond the time specified herein. This remedy shall be in addition to any other remedies provided in this Agreement or at law or in equity to the City in the event of default by Concessionaire.

Date Adjustment Required When ...

- **Possession Date Changes.** If the actual date of possession of the Concession Space by the Concessionaire is after the Target Possession Date, the amount of time between Target Possession Date and date of actual possession shall be added to the Design and Construction Deadline, the Required Opening Date, the Refurbishment Completion Date, the Rent Commencement Date and the Expiration Date and the new dates shall be added to **Exhibit D**. Possession of the Concession Space earlier than the Target Possession Date, shall not affect the Design and Construction Deadline, the Required Opening Date, the Refurbishment Completion Date and the Expiration Date.
- **Design and Construction Deadline Changes.** If the Design and Construction Deadline is enlarged pursuant to the authority reserved to the Manager in Section 6.02, the amount of time by which the Design and Construction Deadline is enlarged shall be added to the Required Opening Date, the Refurbishment Completion Date, the Rent Commencement Date and the Expiration Date and the new dates shall be added to **Exhibit D**.

No Amendment Required. The Parties agree that each of these required date adjustments and the corresponding adjustment to **Exhibit D**, may be taken without the requirement of a formal amendment to this Agreement.

Lien Releases and Other Documents. Within 60 days after the earlier of (a) completion of construction of the initial Improvements or (b) Concessionaire Opens for Business, Concessionaire shall deliver to City original executed copies of all mechanics' lien releases or other lien releases notarized and unconditional, in such form as City shall have approved, and an architect's certification that the Improvements have been constructed in strict accordance with the approved Final Plans and are fully complete in accordance with **Exhibit X**. Concessionaire agrees that, upon the request of the City, Concessionaire will inspect the Concession Space jointly with the City to verify as-built drawings.

6.13. RESTRICTION ON CHANGES AND ALTERATIONS

Subsequent Construction Requires Prior Approval. After construction and installation of the initial Improvements Concessionaire agrees not to materially improve, change, alter, add to, remove or demolish all or any part of the Improvements without the prior written consent of the Manager or the Manager's authorized representative.

Concessionaire to Comply with all Imposed Conditions. Subsequent construction work occurring during the Term (or any extended term) of this Agreement, including all repairs, refurbishments, and remodeling, shall be subject to the prior written approval of the City and, if required, in the determination of the City, an NTP. If subsequent work is approved, the same process outlined above for City approval of the work shall be followed, unless otherwise directed by the City. Concessionaire must comply with all conditions imposed by the Manager's authorized representative in the representative's judgment and all required approvals, submittals, and procedures of whatsoever nature, as set forth in the City's approval. Any work necessary to make alterations, improvements or additions to the Concession Space throughout the Term (or any extended term) of this Agreement shall be done at the Concessionaire's cost and expense.

Revised Drawings, Final Waivers to be Provided. Upon completion of subsequent construction work, the Concessionaire shall deliver to the City revised as-constructed drawings, evidence of payment, contractor's affidavits and full and final waivers of any liens for labor, services or materials. The Concessionaire shall include in its agreement with its contractors provisions whereby such contractors shall defend and hold the City harmless from all costs, damages, liens and expenses related to such work.

Removal and Demolition of Improvements. Concessionaire shall not replace, remove or demolish, in whole or in part, any Tenant Improvement on the Concession Space during the Term (or any extended term) of this Agreement without the prior written approval of the Manager's authorized representative. The Manager's authorized representative may, in its sole discretion, condition such approval upon the obligation of Concessionaire to replace the Improvement by a comparable improvement specified by the Manager's authorized representative.

City may Demand Removal or Satisfactory Changes. In the event that any construction, improvement, alteration, modification, addition, repair (excluding emergency repairs), or replacement is made without the prior written consent of the Manager's authorized representative, or made in a different manner than approved, the City may terminate this Agreement in accordance with the provisions for termination herein, or upon notice to do so, Concessionaire will remove the same, or, at its discretion, cause the same to be changed to the satisfaction of the City. In case of any failure on the part of Concessionaire to comply with the notice, the City may, in addition to any other remedies available to it, effect the removal or change referenced above in this Section and Concessionaire shall pay the cost thereof to the City upon demand.

6.14. REFURBISHMENT OF CONCESSION SPACE

Applicability of this Section. If the Term of this Agreement or any extension of the Term is greater than five years, then mid-term refurbishment of the Concession Space is required and this Section applies. If the Term is or becomes ten years or greater, then refurbishment shall occur in the 4th and 7th year of the Term and the provisions of this Section apply to both dates. If the Term of this Agreement is five years or less, then no mid-term refurbishment is required and this Section does not apply.

Aesthetic Refurbishment. If the Term or any extension of the Term is greater than five years, Concessionaire agrees to refurbish the space in an amount not less than twenty percent of the Required Minimum Investment stated on the Summary Page and thereafter, in an amount not less than ten percent of the Required Minimum Investment for each subsequent refurbishment required by the provisions of this Section 6.14. Of these minimums, an amount consisting of no less than 50% of the minimum refurbishment investment required by this Agreement shall be allocated to aesthetic refurbishment, defined as replacement of all parts of the premises visible to, used by, and/or provision for enhanced service to the public including but not limited to signage, flooring, paint, finishes, fixtures, furnishings, lighting, ceiling and millwork. Life safety and health code upgrades are not considered aesthetic refurbishment. Each refurbishment of the Concession Space required by this Agreement shall be completed and documented as provided below.

Refurbishment Deadline and Investment. At a time commencing no earlier than 180 days before and no later than the Refurbishment Completion Date(s) specified on the Summary Page, or any other refurbish deadline required by this Agreement, Concessionaire, at its sole cost and expense, shall have completed all design and aesthetic refurbishments approved by the Manager, shall have updated and completed all repairs/refurbishments necessary to comply with current applicable life safety and health code requirements and shall have completed renovating and refurbishing the Improvements in the Concession Space required by the Manager at a minimum investment described above.

Refurbishment Investment Documentation. Within 90 days of completion of each refurbishment required by this Agreement, Concessionaire shall file with the Manager a statement certified by its architect setting forth the total refurbishment costs, with appropriate detail itemizing the elements of decorations, furnishings, fixtures, and equipment. When documenting each refurbishment minimum investment required by this Agreement, architectural and engineering charges not exceeding 15% of the total investment may be included. Financial costs, interest, inventory, pre-opening expenses, loss of revenue related to construction or intra-company charges related to construction, shall not be included. At City's request, Concessionaire shall also submit copies of invoices supporting such costs. If the total cost of the Concessionaire's refurbishment investment is less than the Minimum Refurbishment Investment, the difference between such total cost and the Minimum Refurbishment Investment for renovating the Concession Space, shall be paid to City within 30 days after written notice from City to Concessionaire.

Design Plans due in Advance. For each refurbishment of the Concession Space required by this Agreement, Concessionaire shall provide proposed design plans and specifications to the Manager's authorized representative for approval no later than one (1) year prior to Refurbishment Completion Date(s) specified on the Summary Page or any other refurbishment deadline required by this Agreement, or such lesser time as is agreed to in writing by the Manager's authorized representative. The refurbishment of the Concession Space shall be accomplished in accordance with the requirements of this Section 6.

Permission to Operate During Refurbishment. Should Concessionaire's refurbishment plans require Concessionaire to close during construction, Concessionaire may be permitted to operate temporarily from a free standing unit placed in the common area outside of the Concession Space with the Manager's prior written approval, which approval may not be unreasonably withheld. If such a temporary operation is approved, Concessionaire will operate in accordance with the requirements of this Agreement unless otherwise directed by the Manager's authorized representative. Concessionaire must comply with all conditions imposed by the Manager, including but not limited to time, place, manner, construction and installation of, and the type of free standing unit from which Concessionaire is permitted to operate, the food or beverage items to be offered for sale and prices to be charged for each item, number of employees that may operate from the unit at any given time, hours of operation, signage, waste disposal, sanitation, hygiene and cleanliness and janitorial services as well as all required approvals, submittals, and procedures of whatsoever nature, as set forth in the Manager's approval. Concessionaire shall operate from the temporary location in a first-class, dignified and ethical manner satisfactory to the Manager's authorized representative. Any work necessary to accommodate Concessionaire's request to operate temporarily during the refurbishment period, including but not limited to accommodating Concessionaire's temporary needs for water service, electricity, natural gas, lighting, or HVAC, shall be at the

Concessionaire's cost and expense. Prior to beginning any such work, Concessionaire shall notify the City in advance of what type of work it intends to do and must secure written City approval of the same before beginning any such work. Costs and expenses associated with such work shall be paid promptly when due and shall be accomplished free of liens of mechanics and materialmen. Concessionaire shall provide evidence of insurance policies demonstrating adequate coverage for Concessionaire's temporary operation and Concessionaire, at all times and at its sole cost and expense, shall display where applicable and maintain current federal, State, and local licenses, certificates, permits and any other such documents necessary or required by law for the operation of Concessionaire's business at the Airport. Concessionaire shall comply with all applicable health, safety and sanitary laws, regulations and inspections concerning its operations in the temporary location. Concessionaire shall keep such licenses and permits displayed on the free standing unit, as may be required by law. Concessionaire shall allow duly authorized representatives of governmental entities access to the free standing unit and its temporary operations for inspection purposes.

6.15. TITLE TO IMPROVEMENTS

Concessionaire agrees that all Improvements to the Concession Space, including approved changes and renovations, shall become the property of the City upon their completion and acceptance by the City.

6.16. DUTIES UPON SURRENDER

Performance of All Obligations. By the Expiration Date, or upon the earlier termination of this Agreement or on the date specified in any demand for possession by City after any default by Concessionaire, Concessionaire must have fully performed all of its obligations under this Agreement, including: (a) delivery of all keys to any doors and to any Improvements located on the Concession Space to the City; (b) removal of Concessionaire's Equipment; (c) surrender of the Concession Space as required in Section 4.02; and (d) performance of any other obligations required to be performed pursuant to this Agreement prior to termination under this Agreement.

Failure to satisfy any of the above shall allow the City, at the City's sole option, to treat Concessionaire as a holdover tenant at sufferance, as provided in Section 4.03, and Concessionaire shall pay 150% of the MMG (prorated on a daily basis) until such time as Concessionaire has fulfilled all of its obligations under this Agreement.

Improvements to be in Good State of Repair. If the Manager's authorized representative determines in his commercially reasonable judgment upon such expiration or termination, that the Concession Space was not surrendered in accordance with the preceding standard, then Concessionaire, at its sole cost, shall have the option of either of the following actions: (i) bringing such specified Improvements up to the above referenced standard or (ii) removing the Improvements or such portion thereof as is specified by the City. Either option shall be completed by Concessionaire within 10 days of such expiration or termination or within such additional time as is granted by the City. During this 10-day period Concessionaire will be deemed to be holding over at sufferance and shall pay 150% of the MMG (prorated on a daily basis) until the Concession Space is returned in the condition required.

Restoration at Concessionaire's Expense. If all or any portion of the Improvements are removed by Concessionaire either at any time during the Term (or any extended term) or in

accordance with this Section 6.16, Concessionaire shall at its expense restore any City property damaged to conditions existing prior to the installation of such Improvements or applicable portions thereof, and upon Concessionaire's failure to do so the City may cause such removal and restoration to be done at Concessionaire's expense.

Concessionaire to Remove its Equipment. Concessionaire shall retain title to and shall remove, at its sole cost, prior to the expiration or termination of this Agreement, all of Concessionaire's Equipment, as defined in Section 2.07.

Manner of Removing Concessionaire's Equipment. Concessionaire shall remove Concessionaire's Equipment in a manner and at times that do not interrupt other business at the Airport or operations of the Airport. Concessionaire agrees, at its sole cost, at or prior to the expiration or termination of this Agreement, to repair any injury or damage done to the Concession Space, or other City-owned property, resulting from the removal of Concessionaire's Equipment, in good and workmanlike fashion and to place the Concession Space in the same condition as the Concession Space would have been if such Concessionaire's Equipment had not been installed, ordinary wear and tear excepted.

Failure of Concessionaire to Remove its Equipment. If Concessionaire fails to remove any of Concessionaire's Equipment by the expiration or termination of this Agreement, City at its option, may take immediate title to and retain any such Concessionaire's Equipment at no cost to the City. In the alternative, the City may dispose of all or portions of Concessionaire's Equipment and retain any proceeds therefrom. In addition, if City removes any such Equipment, the Concessionaire agrees to indemnify and hold City harmless from all costs, losses, expenses or damages incurred in relation to the removal of such Equipment, including without limitation all costs of associated remedial actions, fines or penalties, reasonable attorney fees, engineering fees and other professional expert fees and upon demand, Concessionaire agrees to reimburse the City as provided in Section 5.09.

SECTION 7 – CONCESSIONAIRE'S OPERATING OBLIGATIONS

7.01. FIRST CLASS CONCESSION

Concessionaire acknowledges the City's vision for the concession program at Denver International Airport. In that spirit, Concessionaire agrees to create and maintain a vibrant first-class concession in a manner satisfactory to the Manager or the Manager's authorized representative.

7.02. PRICING

Final Pricing. At least 30 days prior but no more than 60 days prior to Opening for Business, Concessionaire shall provide for the City's final review and approval a final **Exhibit E**, confirming the menu of items to be offered for sale and prices to be charged for each item and clearly indicating changes, if any. Any such changes to this menu and pricing when compared to Concessionaire's proposal shall be subject to approval by the Manager's authorized representative. This final approved food and beverages and pricing list will be attached to this Agreement as the new Approved Menu. The City may request additional lists with pricing at any time for its approval. Concessionaire shall display and sell food and beverage items only in accordance with Concessionaire's Proposal and the terms of this Agreement. Without causing

Concessionaire to violate its franchise or license agreement(s), City, from time to time, and at its sole discretion, may require Concessionaire to offer for sale, at a fair profit, other items that City determines are necessary to serve the traveling public. Concessionaire shall only sell food and beverage items with pricing clearly visible and legible to customers prior to their making a purchase.

Prices to be Fair and Reasonable. Concessionaire shall charge only fair and reasonable prices for its food and beverage items, subject to the following: Pricing shall conform to all applicable laws and regulations respecting truth-in-advertising. Concessionaire shall not in any manner misrepresent to its customers the quality, grade, point of origin, or the size, weight or portion of food or beverages sold, or utilize false or deceptive merchandising terms or advertising. Where an item has a pre-marked or suggested retail price established by the manufacturer or distributor, Concessionaire shall not charge a price to the public higher than such pre-marked or suggested retail price.

Pricing Policy. Without exception, prices charged by Concessionaire shall not exceed the Airport's "pricing policy," which means Concessionaire shall charge prices no higher than 110% of "street prices" charged in comparable non-airport facilities offering similar food or beverage items in the Denver metropolitan area. Concessionaire's prices shall be subject to the approval of the Manager's authorized representative.

Pricing to be Comparable. Food and beverage items, including alcoholic beverages, if allowed, offered at the Concessionaire's Concession Space shall be comparable to the quality, portion or kind offered at the Concessionaire's restaurants or other comparable establishments in Denver and surrounding Areas (Adams County, Arapahoe County, Jefferson County) and the pricing shall conform to the City's pricing policy. The intent of the City's pricing policy is to maintain consistency in the quality, portion and pricing for food and beverages, including alcoholic beverages, between Concessionaire's locations at the Airport and Concessionaire's locations not at the Airport, but within Denver or the surrounding Areas. If a Concessionaire has one or more businesses bearing the same name within Denver or surrounding Areas, that facility or those facilities will be designated as "Comparable Facilities," and the quality and portion offered at the Airport must be the same as those at the off-Airport Comparable Facilities. If Concessionaire does not have the same business elsewhere in the Denver or surrounding Areas, or if there are items sold at Concessionaire's Airport concession that are not sold at any of Concessionaire's off-Airport Comparable Facilities, Concessionaire and the City will identify three (3) restaurants in Denver or surrounding areas that are similar in concept, size, and quality, as identified on **Exhibit H**, which shall hereinafter be considered comparable for the purposes of implementing the pricing policy terms of this Section 7.02. **Exhibit H** may be modified if any location identified thereon ceases business, changes its business concept, or the City determines that the identified restaurant is no longer comparable for the purposes of this Agreement. In that case, the City and Concessionaire shall agree on a replacement so that there are three (3) comparable locations. If the Parties fail to reach agreement, the City will select the replacement location. Any revisions to **Exhibit H** permitted by this Agreement shall be evidenced in writing and made without the necessity of formally amending this Agreement.

Increase in Prices. Concessionaire may change prices on **Exhibit E**, the Approved Menu, only with the City's prior written approval of the Manager's authorized representative. Concessionaire shall notify the City promptly, in writing, in a manner acceptable to the City of each price change or change in product quality, grade, size, weight or portion. Written

notifications of price changes under this Section 7.02 shall be made in accordance with the notice requirements of Section 14.15. Concessionaire must base any requested increase on rising prices for the same items at the Comparable Facilities identified on **Exhibit H**. In no event shall the price of an item charged by Concessionaire exceed the lesser of (i) 110% street pricing as required by the Airport's Concession Policy (which may be changed from time to time), (ii) an advertised price for the item, (iii) the price of the item as it is listed on **Exhibit E** or (iv) the price of an item at any location listed on **Exhibit H**. Concessionaire will submit new menus to the City when pricing changes are approved. Such new menus will then become the new Approved Menu, automatically replacing and superseding the old Approved Menu. If, in the opinion of the City's Concessions Director, prices do not meet the requirements of this Section 7.02, Concessionaire will adjust the prices accordingly.

Pricing to be Clearly Visible. Concessionaire shall conspicuously indicate prices via menu, menu board, or individually marked items in a manner that is clearly visible and legible to customers prior to their making a purchase. With the prior approval of the Manager's authorized representative, some prepackaged items may be individually priced if such pricing is readily visible and legible to customers prior to the purchase.

City Price Checking, Monitoring. The City may conduct price checking at any time in order to ensure compliance with this Agreement. In the event that the City determines Concessionaire is not in compliance with the pricing requirements of this Agreement, the City will notify Concessionaire and Concessionaire agrees to adjust its pricing immediately upon receipt of the City's notice so as to be in full compliance with the requirements of this Agreement.

7.03. MENU CHANGES

Concessionaire's Approved Menu is attached as **Exhibit E**. Concessionaire may add or delete single items within the Approved Menu only with the prior written approval of the Manager's authorized representative. Concessionaire shall notify the City of its request to add or delete items promptly, in writing, in a manner acceptable to the City and in accordance with the notice requirements of Section 14.15. Such notices must demonstrate that pricing of the item(s) proposed to be added are in accordance with the Airport Concession Policy. When changes are approved, Concessionaire will submit a new Approved Menu to the City, which will replace and supersede the old Approved Menu. Each of these actions may be taken without the requirement of a formal amendment to this Agreement.

7.04. CREDIT CARDS AND DEBIT CARDS

Concessionaire shall accept, and in accordance with Section 7.08, display its acceptance of gift certificates, airline vouchers, traveler's checks, debit cards and nationally recognized credit cards including, but not limited to, American Express, MasterCard, VISA and Discover. No minimum credit card or debit card purchase amount or charge for credit card purchases is allowed.

7.05. MANAGEMENT, SERVICE EMPLOYEE AND OPERATIONAL STANDARDS

Management. The operation and management of the Concession Space shall be under the constant and direct supervision of a well-trained, qualified and experienced manager employed by Concessionaire. The manager shall have the authority to make all decisions necessary in

the day-to-day operations of the Concession Space, including, without limitation, decisions regarding food and beverage returns or credits, customer complaints or concerns, food and beverage quality and pricing, and employee conduct. The manager shall be available on-site during the majority of operating hours and when not on the Concession Space, the manager shall appoint an assistant manager, or shift lead, with authority to act on the Manager's behalf, and/or the ability immediately to contact the manager in order to be able to respond promptly to customer or City concerns. Concessionaire may be required to employ more than one (1) manager to meet the requirements set forth herein.

Service Standards. Concessionaire shall employ sufficient personnel to staff and meet the reasonable needs or demands of customers during all required hours of operation including, but not limited to, maintenance of the Concession Space as needed. All customers shall receive prompt, attentive and courteous service and in the case of a restaurant or food and beverage enterprise, Concessionaire shall upon request issue one guest check per person. Processing of customer purchases, returns and exchanges shall be prompt and Concessionaire shall visibly display its return and exchange policy. Concessionaire shall properly itemize receipts, which shall reflect precisely the actual sale of goods and shall present individual prices, totals and taxes, if any. In addition, receipts must also include Concessionaire's name or store name, store location (e.g. concourse B) and a customer service telephone number.

Concessionaire shall ensure that all personnel refrain from any loud, boisterous, offensive or inappropriate conduct, and that they treat all customers professionally, equally and courteously, including but not limited to forms of address, without regard to race, creed, color, national origin, ethnicity, age, disability, gender or sexual orientation. Concessionaire shall use reasonable efforts to employ an adequate number of bilingual personnel to serve English and non-English-speaking customers as market demand may warrant.

Employee Standards. Concessionaire shall recruit, provide proper training to ensure the certification and/or licensing of employees in all areas of service as their duties might practically and legally require, supervise, direct and deploy the number of qualified, trained and courteous employees necessary to provide services promptly to all customers in accordance with the service standards of a first-class concession. All employees shall be informative and helpful to the public. All employees shall be clean, neat, professional, courteous and of the highest character. All employees shall be attired appropriately and professionally in clean identifiable dress and in keeping with attire worn by personnel in similar first-class businesses in the Denver metropolitan area. All employees must at all times properly display the official Airport identification badge and Concessionaire's identification name tag. Concessionaire's identification name tag shall clearly display the name of the Concessionaire. In the event that the City initiates one or more customer service programs for employees of tenants operating concessions at the Airport, City reserves the right to require Concessionaire to fully participate (and cause its employees to participate) in such programs and shall pay immediately to the City its share of such costs upon invoice by the City.

Concessionaire Surveys (Customer Feedback Cards). Concessionaire agrees to display openly Customer Feedback Cards that are approved and furnished by the City for the purpose of monitoring the quality of the Concessionaire's business from the perspective of its customers. Concessionaire agrees to give the City a copy of any and all completed Customer Feedback Cards that it receives on a weekly basis.

Sales and Dignified Use. Concessionaire's employees and agents shall not engage in "high pressure" sales tactics (such as "hawking" or "haggling") or unfair or deceptive trade practices in the operation of the concession. Concessionaire is strictly prohibited from engaging in any and all activities outside the Concession Space within the Airport for the recruitment or solicitation of business. Additionally, Concessionaire's employees and agents shall not engage in solicitation for or in connection with any services offered on or about the Airport by Concessionaire or any other party.

Concessionaire shall not conduct a public or private auction, fire sale, going out of business, bankruptcy or similar types of sales in or from the Concession Space, unless otherwise approved by the Manager's authorized representative. The Concession Space shall be used only in a dignified and ethical manner, consistent with the general high standards of other first-class concessions operating at the Airport.

7.06. DELIVERIES

Deliveries and Vendor Access. Concessionaire shall receive and take all deliveries of money, coin, supplies, goods and food and beverage items in such manner and at such times and locations as the Manager or the Manager's authorized representative may reasonably approve or require.

Transportation of Deliveries within the Airport. All goods should be packaged within sealed containers that prevent damage or leakage during transportation. In transporting food and beverages, products, trash, and refuse associated with operating Concessionaire's business to and from the Concession Space, Concessionaire shall use only those delivery and receiving routes established by the City and shall use only carts provided by Concessionaire to handle merchandising or equipment, vehicles, or conveyances ("Delivery Carts") that are sealed and leak-proof and have only gray bumper pads. Pallet jacks, if used as Delivery Carts, may only be utilized on the ramp level of the Terminal. If delivery and receiving routes are carpeted, Delivery Carts must be equipped with wheels suitable for operating on carpets without causing damage to them. Delivery Carts may only be used in those elevators designated for delivery. Under no circumstances may Delivery Carts be taken onto the escalators or moving sidewalks. Concessionaire must always refrain from transporting operating materials, such as office supplies, inventory, food, recyclables and trash through the Public Areas of the Airport whenever service corridors and delivery tunnels are available. Concessionaire is responsible for the compliance with these requirements by its vendors.

7.07. HOURS

Hours of Service/Continuous Operation. Concessionaire agrees to schedule its daily hours of operation in accord with the hours stated on the Summary Page and at a minimum, keep the Concession Space Open for Business to the public during the hours per day stated on the Summary Page, seven days a week, 365 days a year, unless otherwise agreed to by the City in writing.

Unusual Circumstances. Concessionaire shall use its best efforts to respond to any and all weather emergency and/or flight diversion situations that might require certain locations to open or remain open before or beyond these minimum hours. In unusual circumstances (e.g.,

diversions, delayed flights, weather), the City reserves the right to require Concessionaire to open its Concession Spaces before or remain open beyond the designated operating hours.

7.08. SIGNS, WINDOW DISPLAYS AND ADVERTISING

Signage Standards. Concessionaire understands and agrees that City has established criteria so that all signs conform to certain uniform standards and criteria and that those criteria are set out in the DIA Design Standards and the DIA Tenant Development Guidelines. City shall have the right in City's sole discretion to prohibit any sign proposed by Concessionaire.

Storefront Signs. Concessionaire shall affix a sign to the exterior surface of the storefront of the Concession Space, subject to the advance approval of and field inspection by the Manager or the Manager's authorized representative. Concessionaire shall pay all costs of fabricating, constructing, operating and maintaining such sign including, without limitation, all charges for electricity. Concessionaire shall keep said sign well lighted during such hours as the Manager's authorized representative shall designate, and shall maintain said sign in good condition and repair during the entire Term (or any extended term) of this Agreement.

Interior Concession Space Signs. The City will permit, at Concessionaire's sole cost and expense, Concessionaire to install and operate signs on the Concession Space, that are professionally fabricated and/or printed or hand drawn by a professional artist, but Concessionaire shall not install any sign until the sign has been approved, in writing, by the City. Concessionaire shall request the City's approval by submitting a written request, accompanied by a detailed rendering or drawing of the proposed sign and the proposed location. All signs must conform to the minimum requirements established by the signage standards contained in the DIA Tenant Development Guidelines and the DIA Design Standards, which standards may be modified by the City from time to time. All signs located in the interior of the Concession Space shall be in good taste so as not to detract from the general appearance of the Concession Space or the Airport. No symbol, design, name, mark or insignia adopted by the City for the Airport shall be used without the prior written consent of the City. Under no circumstances shall any handwritten or temporary signs or displays be posted or used by Concessionaire, including but not limited to any price lists or employment opportunity signs in the Concession Space.

Decals. Subject to the prior written approval of the Manager's authorized representative with respect to size, design and placement, Concessionaire may place decals relating to credit or charge cards accepted on glass storefronts where warranted.

Signs to be Removed. At Concessionaire's sole cost and expense, upon demand by the Manager's authorized representative, Concessionaire shall immediately upon receipt of such demand, remove any sign installed in violation of the foregoing provisions. At Concessionaire's sole cost and expense, Concessionaire shall return the site of such sign to its condition prior to the placement or erection of the sign.

Advertising. Concessionaire may not advertise in the Airport, except with an advertising company that has contracted with the City's advertising contractor to sell advertising at the Airport. Permission will not be granted to Concessionaire for any other advertising at the Airport. Concessionaire shall not use nor permit the Concession Space to be used as a

medium for third party paid advertising including sponsorships or any advertising material, sign, fixture or equipment whether paid for in-kind or by cash or credit.

7.09. VENDING MACHINES

No amusement or vending machines or any other machines operated by coins, paper currency, tokens or credit/debit cards, except those expressly permitted under this Agreement, shall be installed or maintained in or upon the Concession Space. This prohibition includes, but not by way of limitation, sales from vending machines of such items as cigarettes, candy, maps, coffee, soft drinks, newspapers, stamps and insurance policies; telephones; dispensation of cash, money orders and checks; and operation of mechanical or electronic game devices, electronic video games, and entertainment devices.

7.10. COMPLIANCE WITH ALL LAWS AND REGULATIONS

No Prohibited Use. Concessionaire agrees not to use or permit the Concession Space to be used for any purpose not authorized hereunder or prohibited by the laws of the United States or the State of Colorado, the ordinances or Charter of the City and County of Denver, and it further agrees that it will use the Concession Space in accordance with all applicable federal, state and local laws and all general rules and regulations adopted by the City or the Manager for the management, operation and control of the Airport, either promulgated by the City on its own initiative or in compliance with regulations or actions of the Federal Aviation Administration or other authorized federal agency. Concessionaire further agrees to submit any report, reports or information which the City is required by law or regulation to obtain from Concessionaire or which the Manager may request relating to Concessionaire's operations.

Americans with Disabilities Act. Without limiting the foregoing, Concessionaire shall determine and assess the requirements to design, construct, operate and shall at all times maintain the Concession Space in accordance with and in compliance with the requirements of the Americans with Disabilities Act, 42 USC §12,000 et seq., including the ADA Accessibility Guidelines and all federal regulations adopted pursuant to the ADA. In the event that compliance cannot be achieved, Concessionaire shall proceed formally to the federal agency having jurisdiction for a waiver of compliance. If, as a result of Concessionaire's use or occupancy of the Concession Space, or the making of any alterations, additions, or improvements therein, any additions, alterations, or improvements must be made by the City to any part of the Airport in order to comply with any requirements of the ADA, or any other laws, codes or regulations, Concessionaire shall reimburse the City, on demand, for the costs incurred by the City to effect such compliance.

Prevailing Wage Obligation. Concessionaire shall pay and Concessionaire shall require its contractor and sub contractors to pay to every worker, laborer or mechanic employed by them in the performance of any work at DIA that is that is subject to this Agreement and covered by §20-76 of the Denver Revised Municipal Code, prevailing wages, including fringe benefits or their cash equivalent, for the same class and kind of work in the City and County of Denver, as determined by the Career Service Board under the provisions of Section 20-76 of the Denver Revised Municipal Code and shall furnish copies of certified payroll records to the City for all such workers for each week during which covered work was performed.

M/W/BE Obligation. Concessionaire agrees to comply with the Minority Business Enterprises ("MBE") and Women Business Enterprises ("WBE") requirements of Article III, Divisions 1 and 3 of Chapter 28, of the Denver Revised Municipal Code ("MBE/WBE Ordinance"), or applicable successor ordinance, in the design and construction of Improvements throughout the Term (or any extended term) of this Agreement. Concessionaire agrees to comply with rules and regulations issued by the Director of the Division of Small Business Opportunity ("DSBO"), a division of the Mayor's Office of Economic Development. The DSBO Director will set goals for design and construction in accordance with the MBE/WBE Ordinance. Concessionaire shall meet, or make a good faith effort to meet, such goals. Concessionaire shall submit to DSBO monthly reports in a form satisfactory to DSBO identifying all MBE and WBE firms and the amounts spent with such firms during the preceding month for the purpose of demonstrating compliance by Concessionaire with this Section 7.02.

ACDBE Obligation. This Agreement is subject to the requirements of the U.S. Department of Transportation's regulations, 49 CFR Part 23. The Concessionaire agrees that it will not discriminate against any business owner because of the owner's race, color, national origin, or sex in connection with the award or performance of any concession agreement, management contract, or subcontract, purchase or lease agreement, or other agreement covered by 49 CFR Part 23. Concessionaire agrees to include the above statements in any subsequent concession agreement or contract covered by 49 CFR Part 23 that it enters into and causes those businesses to similarly include the statements in further agreements. The DSBO may also establish ACDBE concession specific goals as a percent of annual gross receipts to be undertaken by the Concessionaire under this Agreement. The Concessionaire agrees that it shall make good faith efforts, as defined in Appendix A, 49 CFR Part 26 (Attachment 1), to meet the concession specific goals for ACDBE participation in the performance of this Agreement. Concessionaire acknowledges that any action or failure to act by it, which violates the ACDBE requirements of this Agreement, constitutes a material breach of this Agreement, which shall entitle the City to exercise all of its rights at law or equity for such material breach.

7.11. COMPLIANCE WITH ENVIRONMENTAL REGULATIONS

Concessionaire, in conducting any activity on the Concession Space or in any common area outside of the Concession Space, shall comply with all applicable local, state or federal environmental rules, regulations, statutes, laws or orders (collectively "Environmental Requirements") including but not limited to Environmental Requirements regarding the storage, use and disposal of Hazardous Materials or Special Wastes and regarding releases or threatened releases of Hazardous Materials or Special Wastes to the environment. For purposes of this Agreement the terms "Hazardous Materials" shall refer to those materials, including without limitation asbestos and asbestos-containing materials, polychlorinated biphenyls (PCBs), oil or any other petroleum products, natural gas, source material, pesticides, and any hazardous waste, toxic substance or related material, including any substance defined or treated as a "hazardous substance," "hazardous waste" or "toxic substance" (or comparable term) in the Comprehensive Environmental Response, Compensation and Liability Act (42 U.S.C. Sec. 9601 et seq. (1990)), the Toxic Substances Control Act (15 U.S.C. Sec. 2601 et seq. (1990)), and any rules or regulations promulgated pursuant to such statutes or any other applicable federal or state statute. Concessionaire shall comply with the City's Ordinance 196, as amended on March 18, 1991 (amendments to the City Uniform Public Code related to water conservation fixtures).

Concessionaire shall acquire and comply with all necessary federal, state and local environmental permits and requirements.

Concessionaire shall maintain copies of Material Safety Data Sheets (MSDS) for all chemicals used in the operation of the concession, including for cleaning and maintenance. This obligation is continuing for the Term (or any extended term) of this Agreement and Concessionaire shall make this documentation available for inspection by DIA upon request.

Concessionaire agrees to ensure that its Concession Space is designed, constructed, operated and maintained in a manner that minimizes environmental impact through appropriate preventive measures and complies with all federal, state and local environmental requirements. Concessionaire agrees to evaluate methods to reduce the generation and disposal of waste materials. Wastewater from maintenance or operational activities shall be pretreated with sand and grease traps.

In the case of a release, spill or leak as a result of Concessionaire's construction, operation or maintenance activities, Concessionaire shall immediately control and remediate the contaminated media to applicable federal, state and local standards. Concessionaire shall reimburse the City for any penalties and all cost and expense, including without limitation attorney's fees, incurred by the City as a result of the release or disposal by Concessionaire of any pollutant or hazardous material on the Airport.

7.12. WASTE OR IMPAIRMENT OF VALUE

Concessionaire agrees that nothing shall be done or kept in the Concession Space which might impair the value of the City's property or which would constitute waste.

7.13. HAZARDOUS USE

Concessionaire agrees that nothing shall be done or kept in the Concession Space and no improvements, changes, alterations, additions, maintenance or repairs shall be made to the Concession Space which might be unsafe or hazardous to any person or property. Further, Concessionaire shall not do or permit to be done any act or thing upon the Concession Space which will invalidate, suspend or increase the rate of any fire insurance policy required under this Agreement, or carried by the City, covering the Concession Space or the buildings in which the Concession Space is located or which, in the opinion of the Manager or the Manager's authorized representative, may constitute a hazardous condition that will increase the risks normally attendant upon the operations contemplated under this Agreement. If, by reason of any failure by Concessionaire to comply with the provisions of this Section 7.13, after receipt of notice in writing from the City, any fire insurance rate on the Concession Space or on the buildings in which the same is located, shall at any time be higher than it normally would be, then Concessionaire shall pay the City, on demand, that part of all fire insurance premiums paid by the City which have been charged because of such violation or failure of Concessionaire; provided, that nothing herein shall preclude Concessionaire from bringing, keeping or using on or about the Concession Space such materials, supplies, equipment and machinery as are appropriate or customary in carrying on its business, or from carrying on the normal operations contemplated herein.

Any nuisance, annoyance or hazardous or potentially hazardous condition, on or emanating from the Concession Space, shall be corrected immediately upon Concessionaire's actual knowledge of the condition, or receipt of oral or written notice from the City. If, in the City's sole discretion, a hazard or potentially hazardous condition presents an unreasonable and imminent risk of bodily injury, the City may require Concessionaire to close its business without compensation and bar the public from the Concession Space until the hazard or potentially hazardous condition has been abated. Nothing in this Section 7.13 shall be deemed to preclude the City from pursuing any available remedy for breach of the provisions of this Agreement. Concessionaire's failure to correct promptly a nuisance, annoyance or hazardous or potentially hazardous condition under this Section 7.13 shall be a material breach of this Agreement.

7.14. WASTE DISPOSAL AND RECYCLING

Waste Disposal and Recycling. Concessionaire shall gather, sort, and transport all garbage, refuse and recyclable materials daily to the City's designated holding area along routes established by the City and in a manner that eliminates spillage and avoids damage to City property. Garbage, refuse and other debris shall be placed in non-broken, non-punctured, new 3-mil trash bags or such other garbage containers as may be required by the City suitable for transportation to a designated bin or compactor in the manner and at the time and places specified by the City. Concessionaire shall participate in the Airport's waste recycling program. Concessionaire shall place all garbage, refuse and recyclable materials in the appropriate containers at the City designated holding area, taking all reasonable measures to reduce the amount of waste it generates by requiring suppliers to remove nonessential over wrap, containers and other packaging, and to use recyclable materials for essential packaging whenever possible. The City currently provides containers for recycling the following: (a) corrugated cardboard; (b) magazines; (c) newspapers; (d) tin and steel cans; (e) glass that is clear, brown, or green; (f) batteries, and (g) high grade office paper, including letterhead, typing paper, colored paper, photocopy paper, and computer paper. Recyclable materials, including food waste, should be placed into the appropriate containers. Except for the recycling of batteries, Concessionaire shall ensure that the following materials are not deposited in City recycling containers: (i) Hazardous Substances, (ii) cans or other containers used to store paint, oil, solvent, cleaning fluids, or other Hazardous Substances; and (iii) un-clean paper, including paper that is soiled with food, paper with plastic covers or windows and wax coated paper. In addition, the City may establish other specific requirements concerning the storage and transport of waste and recyclables in the Airport's Rules and Regulations.

Maintenance of Grease Lines; Grease Disposal and Transportation. When operating a restaurant or food and beverage enterprise, Concessionaire shall keep its grease lines clean and in good working condition and shall provide to the Manager's authorized representative a monthly report to that effect, including but not limited to invoices and receipts of service from Concessionaire's vendor.

Concessionaire will utilize a used fry oil (e.g. fats, oils and grease) container specifically designed for transporting to the appropriate recycling facility. As specified in the Airport Rules and Regulations. Concessionaire shall not inappropriately dispose of cooking oil/liquid grease, such as in Concessionaire's floor drains, mop sinks, or floor sinks. Concessionaire shall be solely responsible for all costs associated with the inappropriate disposal of fry oil generated by its operation on the Concession Space. The City also reserves the right to recover the cost plus

a twenty percent (20%) administrative fee, due to Concessionaire's failure to properly disposed of fry oils as required.

Kitchen Exhaust Hoods and Related Makeup Air and Exhaust Systems. When operating a restaurant or food and beverage enterprise, Concessionaire shall keep its exhaust systems clean and in good working condition and shall provide to the Manager's authorized representative a monthly report to that effect, including but not limited to invoices and receipts of service from Concessionaire's vendor.

Concessionaire will install and maintain kitchen exhaust hoods, makeup air and exhaust systems controls to interface with the City's building automation systems, fire suppression systems, hot water wash down systems and other systems and equipment in accordance with the manufacturer's specifications and as required by Denver Fire and Building Codes and the Tenant Development Guidelines. Concessionaire is solely responsible for all costs associated with the maintenance of kitchen exhaust hoods and related makeup air and exhaust systems.

The City has the specific right to conduct "no notice" inspections of all kitchen exhaust hoods and related makeup air and exhaust systems to ensure that the required level of maintenance is being provided. The results of these inspections will be provided to Concessionaire in writing. Subject to the notice requirement set forth below, if the City determines that Concessionaire is not adequately maintaining its kitchen exhaust hoods and related makeup air and exhaust systems, the City will have the right to hire a third party to undertake the maintenance and repair of Concessionaire's kitchen exhaust hoods and related makeup air and exhaust systems, at Concessionaire's sole cost, plus a twenty percent (20%) administrative fee, for the remainder of this Agreement term.

Notwithstanding the foregoing, the City will provide up to two (2) written notices in any calendar year to Concessionaire, with the time for cure as set forth in Section 11 before it may exercise its option to contract with a third party to perform maintenance of Concessionaire's kitchen exhaust hoods and related makeup air and exhaust systems.

The City also reserves the right to recover the cost of repair or maintenance of heating, ventilating and exhaust systems as well as grease waste, sanitary waste, sanitary sewer and other facility systems that are damaged or adversely impacted by Concessionaire's failure to properly maintain its kitchen exhaust hoods and related makeup air and exhaust systems.

7.15. SANITATION, HYGIENE AND CLEANLINESS.

Sanitation, Hygiene and Cleanliness. Concessionaire shall keep the Concession Space free of debris, trash, and hazardous conditions, shall keep public areas around the Concession Space free of hazardous conditions originating from Concessionaire's operations and shall promptly notify the City in writing of other hazardous conditions in the public areas outside the Concession Space upon actual knowledge of any such hazardous condition. Concessionaire shall provide a proper arrangement for the adequate sanitary disposal of all trash and other refuse on the Concession Space and shall provide for its timely removal to a central collection point provided by the City. Concessionaire shall take appropriate action in the handling of waste materials to prevent the presence of rodents and other vermin. Concessionaire shall keep all garbage materials in durable, fly-proof and rodent-proof, fireproof containers that are easily cleaned. The containers shall have tight-fitting lids, doors or covers, and shall be kept

tightly covered when material is not being deposited in them. Concessionaire shall clean the containers, as necessary, to prevent odors. Concessionaire shall not allow boxes, cartons, barrels, or other similar items to remain within view of public areas. The City shall be responsible for handling and removal of trash and other refuse deposited by the public in public areas. Concessionaire shall not deposit any of its trash or other refuse in any containers except those designated for Concessionaire's trash, as provided in Section 7.14.

7.16. MAINTENANCE OF CONCESSION SPACE BY CONCESSIONAIRE

No City Responsibility to Maintain Concession Space. The Concessionaire shall bear all costs of operating Concessionaire's business on the Concession Space and the City shall have no responsibility to maintain, repair or replace any portion of the Concession Space,

Janitorial Services. Concessionaire shall, at its expense, be responsible for janitorial services for the Concession Space. Concessionaire shall not permit rubbish, debris, waste materials or anything unsightly or detrimental to health, or likely to create a fire hazard, or conducive to deterioration, to remain on any part of the Concession Space or to be disposed of improperly.

Maintenance. Concessionaire shall, at all times and at Concessionaire's sole expense, maintain the Concession Space in a first-class condition, in good repair, ordinary wear and tear excepted, and keep it in a clean and orderly condition and appearance, as conditions and the Manager's authorized representative may require, including but not limited to all Improvements located on and within the Concession Space, whether installed by Concessionaire or by the City, redecoration, painting and repair and replacement of damaged or worn furnishings and equipment, and maintenance, repair and replacement of life safety, fire detection, fire suppression and fire monitoring systems. The City shall be the sole judge of the quality of such maintenance.

Repairs, Replacements and Remodeling. Concessionaire, at its own cost and expense, shall repair, repaint, refinish, maintain and remodel the Concession Space and all Improvements therein promptly. High traffic areas within the Concession Space subject to greater-than-normal wear will be maintained on a schedule to be specified by the Concessionaire as approved by the City. In addition, all Improvements within the Concession Space that become worn, chipped, dented, gouged or otherwise damaged, shall be repaired or replaced by Concessionaire, at Concessionaire's sole expense as soon as reasonably possible. Any requests for repair work shall be submitted to the Airport's Concessions Management team. All repairs, replacements, or remodeling to the Concession Space done by or on behalf of Concessionaire shall be completed with due diligence and in a good and workmanlike fashion, shall be of first-class quality in both materials and workmanship, and shall be equal to or better than the original in materials and workmanship and in compliance with all conditions imposed by City and all applicable permits, authorizations, laws, ordinances, orders, rules and regulations of governmental authorities having jurisdiction.

Except for repairs caused by an emergency, or those costing less than Two Thousand Dollars (\$2,000), all repairs must have the prior written approval of the City. The City shall be the sole judge of the quality of the repairs, replacements, or remodeling performed. Prior to beginning any repair, replacement or remodeling work, except for the above-described repairs costing less than Two Thousand Dollars (\$2,000), Concessionaire shall notify the City in advance of what type of repairs, replacements, or other work it intends to do, including the timeline to finish such

work, and must secure written City approval of the same before beginning any such work. In the event of an emergency repair situation, Concessionaire must notify the City of the repair as soon as possible. Following such notice, the City may inspect the repair work and require alterations if the repair is not satisfactory to the City. The foregoing notwithstanding, all repairs requiring shutdown of any Airport system require prior written approval of the Manager's authorized representative.

Costs and expenses with respect to such maintenance, repair and replacement shall be paid promptly when due and the maintenance, repair and replacement shall be accomplished free of liens of mechanics and materialmen.

In addition, Concessionaire must complete refurbishments to the Concession Space before the midpoint of the Term (or any extended term) as provided in this Agreement.

Failure to Maintain or Repair. If Concessionaire refuses or neglects to undertake the prompt maintenance or repair, which is Concessionaire's responsibility under this Agreement, the City shall have the right to have such work, for which City has provided Concessionaire written notice and an opportunity to cure, done on behalf of and for Concessionaire at the City's standard rates or by a contractor hired by the City, and upon demand, Concessionaire agrees to reimburse the City as provided in Section 5.09.

Damage Caused to Other Property. Any damage caused by Concessionaire to the Airport or any City property or operations, or the property of any other tenant, person or entity, either by act or omission, or as a result of the operations of Concessionaire, shall be the responsibility of Concessionaire. Subject to Section 12.04, and upon demand, Concessionaire agrees to reimburse the City, tenant or other such person or entity for any such damage as provided in Section 5.09. If the same type of damage is caused by the Concessionaire more than once, such as a water leakage, electrical service interruption or other damage, then the City must review and approve Concessionaire's plan of repair and, if such plan is unsatisfactory in the sole determination of the City and the City has provided Concessionaire written notice and an opportunity to cure, the City shall have the right to require that Concessionaire allow the City to make the repair and upon demand, Concessionaire agrees to reimburse the City as provided in Section 5.09.

7.17. STRUCTURAL, ELECTRICAL OR SYSTEM OVERLOADING

Concessionaire agrees that nothing shall be done or kept on the Concession Space and no improvements, changes, alterations, additions, maintenance or repairs shall be made to the Concession Space which might impair the structural soundness of the building, result in an overload of utility, plumbing, or HVAC systems serving the Terminal and/or Concourses or interfere with electric, electronic or other equipment at the Airport. In the event of violations hereof, Concessionaire agrees immediately to remedy the violation at Concessionaire's expense.

7.18. NOISE, ODORS, VIBRATIONS AND ANNOYANCES

Concessionaire shall conduct its operations in an orderly and proper manner so as not to commit any nuisance in the Concession Space or annoy, disturb or be offensive to others in the Terminal Complex. Concessionaire shall take all reasonable measures, using the latest known

and practicable devices and means, to eliminate any unusual, nauseous or objectionable noise, gases, vapors, odors and vibrations and to maintain the lowest possible sound level in their operations. No pets are allowed (except as may be permitted or required by law with respect to persons with disabilities) and no lighting device, radio, television, microphone, loudspeaker, telephone, megaphone or other similar device which the City determines to be annoying or offensive shall be used in or about the Concession Space unless prior authorization is given by the City.

7.19. ACCESS TO FACILITY AND SYSTEMS

Concessionaire shall not do or permit to be done anything which might interfere with the effectiveness or accessibility of utility, heating, ventilating or air conditioning systems or portions thereof on the Concession Space or elsewhere on the Airport, nor do or permit to be done anything which may interfere with free access and passage in the Concession Space or the public areas adjacent thereto, or hinder police, firefighting or other emergency personnel in the discharge of their duties. Further, Concessionaire shall not do or permit to be done anything which might interfere with the effectiveness or accessibility of elevators or escalators in or adjacent to the Concession Space, including lines, pipes, wires, conduits and equipment connected with or appurtenant thereto.

Concessionaire shall not place any additional lock of any kind upon any window or interior or exterior door in the Concession Space, or make any change in any existing door or window lock or the mechanism thereof, unless a key therefor is maintained on the Concession Space, or otherwise made available to City upon demand (for example, keys may be kept by Concessionaire's manager if the same are made reasonably available to City when needed as provided herein). If any keys furnished to Concessionaire by the City are lost, Concessionaire shall pay the City, on demand therefor, as Additional Rent, the cost for replacement thereof.

7.20. QUALITY ASSURANCE

Quality Assurance Inspections. The City or its agents may, in its discretion and at any time, inspect, monitor and test Concessionaire's operations for quality assurance ("Quality Assurance Inspections") to ensure compliance with all of Concessionaire's operating obligations set forth in this Section 7. To the extent possible, all Quality Assurance Inspections will be conducted so as not to interfere with Concessionaire's operations and shall, at a minimum, focus on, but not be limited to, the following:

- Concession Space: General upkeep, signage, maintenance, equipment and cleanliness
- Food and Beverage Items: Delivered as represented, taste and attractiveness
- Personnel: Professionalism, appearance, customer service, receipts provided and activity

The City shall provide Concessionaire with written results of the Quality Assurance Inspections. Concessionaire agrees to promptly correct all deficiencies noted in Concessionaire's performance. Concessionaire shall promptly notify the City of the corrections as completed, or request additional time to correct outstanding items where the City determines progress has been made by Concessionaire to correct such deficiencies.

The City may conduct merchandise and price checking at any time in order to ensure compliance with the requirements of this Agreement. In the event that Concessionaire fails to correct in a timely manner the deficiencies noted, the City may elect to impose Sanctions as per Section 10 and/or declare an Event of Default.

SECTION 8 – UTILITIES AND SERVICES

8.01. UTILITIES

Most concession areas in the Terminal and Concourses have services of adequate capacity to supply reasonable amounts of hot or chilled water, gas, electricity, potable water, fire protection, sanitary waste, grease waste and storm sewer capacity to serve the concession areas. The Concessionaire shall verify capacity of all systems, in the Concession Space and shall be responsible for all utility system upgrades that are necessary for their concession build out. As of the date of actual possession, Concessionaire shall be responsible for the payment of all utilities that are required for operations in the Concession Space.

At its option, the City may bill Concessionaire its pro-rata share of certain utilities consumed or estimated to be consumed. In such case, the City will charge a rate no higher than that, which would allow the City to recover the cost of providing the service, which will include but not be limited to standard rates, fees and charges established by the Airport.

8.02. HEATING AND AIR CONDITIONING (HVAC)

Concessionaire shall, at its expense, furnish, install and maintain any ductwork or other connections within or leading into its Concession Space that may be required to connect and complete the HVAC from the Airport's central system for the Concession Space.

City, at its expense, shall furnish normal and reasonable quantities of central air from the central HVAC system to the Concession Space and all necessary power and electricity for such central air circulation. Subject to conditions beyond its control, the City shall maintain under normal conditions a temperature adequate for comfortable occupancy according to the season; provided, that Concessionaire properly maintains the ductwork and other connections within or leading into its Concession Space and complies with the recommendations of the City's engineer regarding reasonable occupancy and use of the Concession Space.

8.03. WATER SERVICE

Concessionaire shall, at its expense, furnish, install and maintain a water meter for the Concession Space, if required by the City, at a location and of a type specified by the City and shall pay all costs for water used within the Concession Space. Concessionaire shall be responsible for all water hook-up of its equipment.

City shall furnish water from the central water source in reasonable quantities; provided that Concessionaire complies with all water conservation programs in effect or as adopted.

8.04. ELECTRICITY AND NATURAL GAS

Concessionaire shall, at its expense, furnish, install and maintain an electric meter and a gas meter for the Concession Space, if required by the City, at a location and of a type specified by

the City, and shall pay all costs for electricity and gas used within the Concession Space. Concessionaire shall furnish, install and maintain all power circuits and connections required for equipment and mechanical systems used in the Concession Space. Any bills by the City for such costs shall be due within 30 days and shall accrue interest at the Past Due Interest Rate if not paid when due.

City will provide a premises wiring system to the Concession Space that will handle electronic information such as telephone and telecommunications equipment. Concessionaire shall be responsible for any extension of the wiring and connection of any terminals and devices in accordance with City requirements, and shall pay for telephone service to the Concession Space.

8.05. LIGHTING

Concessionaire shall, at its expense, furnish, install and maintain all lighting fixtures and wiring for general illumination of the Concession Space. Levels of illumination and wattage requirements shall be subject to approval by City.

8.06. WINDOW WASHING AND STRUCTURAL MAINTENANCE

City shall, at its expense, provide exterior window washing and maintain all structural parts of the Terminal and Concourses, including exterior glass, walls and roof.

8.07. COMMON USE SERVICES

The Manager may establish common use services at the Airport, including but not limited to trash and garbage removal, deliveries, industrial waste handling, recycling and security guards, which Concessionaire may be required to use and pay its actual prorated share.

8.08. INTERRUPTION OF SERVICES

Concessionaire agrees that City shall not be liable for failure to supply any utility services. City reserves the right to temporarily discontinue utility services at such time as may be necessary by reason of accident, unavailability of employees, repairs, alterations or improvements or whenever by reason of strikes, lockouts, riots, acts of God or any other happenings beyond the control of the City, the City is unable to furnish such utility services. The City shall not be liable for damages to persons or property for any such discontinuance, nor shall such discontinuance in any way be construed as cause for abatement of compensation or operate to release the Concessionaire from any of its obligations hereunder, except as otherwise provided in the Section entitled "Damage, Destruction or Loss."

SECTION 9 – INDEMNITY, INSURANCE AND GUARANTEES

9.01. INDEMNITY

Concessionaire hereby agrees to release and indemnify and save harmless the City, its officers and officials, agents and employees from and against any and all loss of or damage to property, or injuries to or death of any person or persons, including property and employees or agents of the City, and shall defend, indemnify and save harmless the City, its officers and officials, agents and employees from any and all claims, damages, suits, costs, expense, liability,

actions, penalties or proceedings of any kind or nature whatsoever, including worker's compensation claims, of or by anyone whomsoever, in any way resulting from, or arising out of, directly or indirectly, its operations in connection herewith, its construction of the Concession Space, or its use or occupancy of any portion of the Airport and including acts and omissions of officers and officials, employees, representatives, suppliers, invitees, contractors, subcontractors, and agents of the Concessionaire; provided, that the Concessionaire need not release, indemnify or save harmless the City, its officers and officials, agents and employees from damages resulting from the sole negligence of the City's officers and officials, agents and employees. The minimum insurance requirements prescribed herein shall not be deemed to limit or define the obligations of Concessionaire hereunder.

9.02. INSURANCE

Required Insurance. Concessionaire agrees to secure at its own expense and to keep in force at all times during the Term (or any extended term) hereof, insurance against claims for injury to persons or damage to property which may arise from or in connection with the performance of obligations under this Agreement by the Concessionaire, its agents, representatives or employees. The types and amounts of insurance coverage Concessionaire must procure are specified in the Certificate of Insurance for Aviation, attached hereto as **Exhibit C**. Insurance requirements set forth on **Exhibit C** do not limit in any way the indemnity covenants contained in this Agreement or the amount or scope of liability of Concessionaire under this Agreement. The amounts listed indicate only the minimum amounts of insurance coverage that the City is willing to accept to help insure full performance of all terms and conditions of this Agreement. Concessionaire specifically agrees to comply with each condition, requirement or specification set forth in **Exhibit C** during all periods when the required coverage is in effect. Insurance must be maintained without any lapse in coverage during the entire Term (or any extended term) of this Agreement. Insurance canceled without the City's consent or failure by Concessionaire to provide evidence of renewal within 48 hours after written notice by City is a material breach and shall be deemed an immediate Event of Default under this Agreement. All insurance required by Concessionaire under this Agreement shall meet the following minimum requirements.

City as Additional Insured. The City shall be named as an additional insured in each general liability policy and as an additional insured and loss payee in each property insurance policy. Such insurance shall provide cross-liability coverage equivalent to the standard Separation of Insured's clause published by the Insurance Services Offices or a successor organization. Concessionaire shall supply the City with certification from the insurance carrier that the City is so named. Each such policy or certificate shall further provide that any coverage afforded the City as additional insured shall apply as primary insurance and other insurance issued to the City shall apply as excess and non-contributing insurance, and will not require any contribution from any insurance or self-insurance carried by the City.

Waiver of Subrogation. Concessionaire and the City waive any right of action that they and/or their insurance carriers might have against each other (including their respective employees, officers, commissioners, or agents) or against other tenants of the Airport for any loss, cost, damage, or expense (collectively "Loss") to the extent that such loss or damage is covered by any property insurance policy or policies maintained or required to be maintained pursuant to this Agreement and to the extent that such proceeds (which proceeds are free and clear of any interest of third parties) are received by the party claiming the Loss. Concessionaire also waives any right of action it and/or its insurance carrier might have against the City (including its

respective employees, officers, commissioners or agents) for any Loss described in Section 12, whether or not such Loss is insured. If any of Concessionaire's applicable insurance policies do not allow the insured to waive the insurer's rights of subrogation prior to a Loss, Concessionaire shall cause it to be endorsed with a waiver of subrogation that allows the waivers of subrogation required by this Section 9.02.

Company Ratings. Policies of insurance must be written by companies having an A.M. Best rating of "A-" or better or equivalent.

Certificates Required. Concessionaire shall furnish the City and County of Denver with certificates of insurance (ACORD form or equivalent approved by the City) as required by this Agreement. The certificate of insurance for each policy is to be signed by a person authorized by the insurer to bind coverage on its behalf. All certificates required by this Agreement (including renewal certificates) shall be sent directly to Denver International Airport, Concessions Management Section, Airport Office Building, Room 9870, 8500 Pena Boulevard, Denver, Colorado 80249. The City's contract control number for this Agreement shall be noted on each certificate of insurance. All certificates and any required endorsements are to be received and approved by the City and each insurance policy required by this Agreement must be in effect at or prior to the Target Possession Date (or date of actual possession, if earlier). Any renewal certificate shall be delivered to the Airport Concessions Management Section at least 10 days prior to a policy's expiration date, except for any policy expiring after the Expiration Date of this Agreement or any extension thereof. The City reserves the right to require and Concessionaire agrees to deliver upon request at any time, complete, certified copies of all insurance policies required by this Agreement.

Certificates evidencing the existence of the policies, in such form as the Manager may require, shall be delivered to the Airport Concessions Management Section prior to the Target Possession Date. Upon written request by the Manager, Concessionaire agrees to furnish to Airport Concessions Management Section at any time thereafter during the Term (or any extended term) of this Agreement the original or a certified copy of said policy or policies.

Deductibles and Retentions. Any deductible or self-insured retention exceeding fifteen percent (15%) of the per-occurrence or per-accident limit of a required policy is subject to approval by the City's Risk Administrator.

Concessionaire's Risk. The City in no way warrants that the minimum limits contained herein are sufficient to protect the Concessionaire from liabilities that might arise out of the performance of the terms and conditions of this Agreement by the Concessionaire, its agents, representatives or employees. Concessionaire shall assess its own risks and as it deems appropriate and/or prudent, maintain higher limits and/or broader coverage. Concessionaire is not relieved of any liability or other obligations assumed or pursuant to the Agreement by reason of its failure to obtain or maintain insurance in sufficient amounts, duration or types. In no event shall the City be liable for any: (a) business interruption or other consequential damages sustained by Concessionaire; (b) damage, theft or destruction of Concessionaire's inventory, improvements, or property of any kind; or (c) damage, theft or destruction of an automobile, whether or not insured. If at any time any of the insurance policies shall be or become unsatisfactory to the City as to form or substance, or if any of the carriers issuing such policies shall be or become unsatisfactory to the City, Concessionaire shall promptly obtain a new and

satisfactory replacement policy and give the City an updated certificate of insurance that complies with the new insurance requirements of the City.

Governmental Immunity. The Parties hereto understand and agree that the City and County of Denver, its officers, officials and employees, are relying on, and do not waive or intend to waive by any provisions of this agreement, the monetary limitations or any other rights, immunities and protections provided by the Colorado Governmental Immunity Act, §§ 24-10-101 to 120, C.R.S., or otherwise available to the City and County of Denver, its officers, officials and employees.

9.03. PERFORMANCE SURETY

Standard Surety Requirements. On or before the Target Possession Date of this Agreement, or the actual date possession is delivered, Concessionaire shall deliver to the Manager, and maintain in effect at all times throughout the Term, including a period of six (6) months after expiration of the Term (or any extended term) or earlier termination of this Agreement, an irrevocable letter of credit or such other acceptable surety as first approved in writing by City, in an amount initially equal to six (6) months of the initial MMG, which is stated on the Summary Page. Such irrevocable letter of credit or other acceptable surety, sometimes referred to herein as "Standard Surety," shall be subject to claim in full or in part by the City, payable without condition to the City with surety acceptable to and approved by the City's Manager, and if a letter of credit, upon presentation of the letter of credit and a sight draft. All irrevocable letters of credit shall be in a form, and issued by a bank, acceptable to the City and shall be subject to claim in full or in part by the City as provided herein. The performance surety shall guarantee to the City full and faithful performance of (i) all of the terms and provisions of this Agreement to be performed by Concessionaire, as said Agreement may be amended, substituted, supplemented or extended, and (ii) all obligations and duties of Concessionaire under all general rules and regulations adopted by the City or the Manager for the management, operation and control of the Airport as amended or supplemented.

Any provision herein to the contrary, notwithstanding, if at any time during the Term (or any extended term) hereof, the Manager deems the amount of the surety insufficient to properly protect the City from loss hereunder because Concessionaire is or has been in arrears with respect to such obligations or because Concessionaire has, in the opinion of the Manager, violated other terms of this Agreement, Concessionaire agrees that it will, after receipt of notice and an opportunity to cure, increase the surety to an amount required by the Manager; provided however, the percentage increase in the amount of surety shall not exceed the annual percentage increase that has occurred with respect to Concessionaire's Minimum Annual Guarantees in effect under this Agreement.

Whether in the form of a surety bond or Irrevocable Letter of Credit, the surety may be issued for a one (1) year period, provided, however, that evidence of renewal or replacement of the surety must be submitted annually by Concessionaire to the City at least sixty (60) days prior to the Expiration Date of the instrument. The surety shall contain language that the surety company shall notify the City in writing within forty-five (45) days of a determination that the surety is to be terminated, or is not going to be renewed. The surety bond must be executed by Concessionaire and by a surety meeting the qualifications set forth below.

If the City chooses to draw upon the Performance Surety as provided in Section 11.02; it shall be the obligation of Concessionaire to replenish the Performance Surety to the originally contracted level within 30 days of such draw down by the City. Failure to maintain or replenish the Performance Surety shall constitute a material breach of this Agreement.

Alternative Surety Opportunity. Alternatively, upon the Concessionaire's request, the Manager may, in her sole discretion, permit Concessionaire temporarily to provide an "Alternative Surety" as defined below.

Alternative Surety Requirements. Payment of the Alternative Surety is due in advance upon notification by the Airport of the amount due.

Base Fee. The Alternative Surety shall be a Base Fee paid to the City of two percent (2%) of the annual rent due by Concessionaire in the prior calendar year, or if a full year is unavailable, 2% of the annualized rent due, as calculated by the City. If no rent payment history is available, or if the Manager, in her sole discretion, determines the existing rent payment history is insufficient, the Base Fee shall be two percent (2%) of the MAG agreed to in this Agreement.

No reduction in Amounts Due. Payment of the Base Fee as surety in no way reduces or offsets the compensation or amounts due from the Concessionaire to the Airport under this Agreement.

Applicable Period of Alternative Surety. The Alternative Surety will apply for one year after all of the following have occurred ("Alternative Surety Period"): (i) Full execution of this Agreement, (ii) issuance of notice of Base Fee and Additional Fee (described below) under the terms of this subsection, and (iii) receipt of payment due of Base Fee and Additional Fee (described below) under the terms of this Section 9.03. At the end of the Alternative Surety Period, the Standard Surety requirements of this Section 9.03 shall automatically apply for the remainder of the Term (or any extended term) of the Concession Agreement unless the Alternative Surety is extended by the Manager.

Extension of Alternative Surety. The Alternative Surety may be extended by the Manager of Aviation, in the Manager's sole discretion, for additional one-year periods through the Term (or any extended term) of this Agreement.

Base Fee Recalculation. The Base Fee shall be recalculated at the end of each Surety Period. The Base Fee may be adjusted by the Manager to account for the following:

1. For every late rent notice issued to Concessionaire, the Manager may, in her discretion, increase the Base Fee by $\frac{1}{2}$ percent of the annual rent due in the prior calendar year ("Additional Fee"); however, if no late rent notices were issued to Concessionaire in the prior calendar year then the Manager may reduce any existing Additional Fee by $\frac{1}{2}$ percent of annual rent due.
2. A factor consisting of some or all of the following: The Airport's general risk due to local or national changes to the aviation industry, the Airport's cost for administering the alternative surety, and the market cost of Letters of Credit, Revenue Surety instruments or similar instruments.

3. In no event shall the recalculated Base Fee be less than 2% of the greater of the following: the annual rent due by Concessionaire in the prior calendar year; or if a full year is unavailable, the annualized rent due, as calculated by the City; or if no rent payment history is available or the Manager, in her sole discretion, determines the existing rent payment history is insufficient, the MAG agreed to in this Agreement.
4. Concessionaire shall be notified of any recalculated Base Fee and Additional Fee in writing by the City at the time the Alternative Surety is extended.
5. If the Alternative Surety is extended and recalculated by the Manager, but Concessionaire no longer desires to comply with the Alternate Surety, Concessionaire may instead submit the Standard Surety required in this Section 9.03.

Termination of Alternative Surety. The Alternative Surety may be terminated at any time at the discretion of the Manager or the Concessionaire upon 30 days written notice to the other party. Upon such termination, the Standard Surety requirements of this Section 9.03 of this agreement shall apply. Any unamortized portion of the Base Fee and Additional Fee for the Alternative Surety shall be refunded to the Concessionaire upon Concessionaire's compliance with the Standard Surety requirements of this Section 9.03

9.04. NO PERSONAL LIABILITY

No director, officer, manager, member or employee of either Party hereto shall be held personally liable under this Agreement or because of its execution or attempted execution.

9.05. LICENSES, FEES, TAXES AND LIENS

Business Licenses. Concessionaire, at all times and at its sole cost and expense, shall maintain current federal, State, and local licenses, certificates, permits and any other such documents necessary or required by law for the operation of Concessionaire's business at the Airport including where applicable those documents governing restaurants, food and beverage enterprises, and the sale of alcoholic beverages, if permitted herein. Concessionaire shall comply with all applicable health, safety and sanitary laws, regulations and inspections concerning the same. Concessionaire shall keep such licenses and permits displayed on the Concession Space, as required by law. Concessionaire shall allow duly authorized representatives of governmental entities access to the Concession Space for inspection purposes. Upon expiration or termination of this Agreement, if Concessionaire holds a liquor license for use within the Concession Space, at the option and upon the written request of the City, and to the extent permitted by applicable law, Concessionaire covenants that it shall convey the rights to such liquor license to any designee of the City for the designee's use within the Concession Space.

Doing Business in Colorado. In the event that Concessionaire shall be a corporation or a limited liability company, the Parties executing this Agreement on behalf of Concessionaire hereby covenant and warrant that Concessionaire is a duly qualified corporation or limited liability company and all necessary steps have been taken to become authorized to do business in Colorado; corporate taxes have been paid to date; and all future forms, reports, fees and

other documents or payments necessary to comply with applicable laws will be filed or paid when due.

Fees. Concessionaire agrees to promptly pay all excises, license fees and permit fees of whatever nature applicable to its operations hereunder and to take out and keep current and display when required all municipal, state or federal licenses required for the conduct of its business at and upon the Concession Space and further agrees not to permit any of said excises, license fees or permit fees to become delinquent.

Taxes and Assessments. The Concessionaire shall pay all taxes and assessments of whatever character that may be levied, assessed, or charged upon the property, possessory interest, personal, occupied, used, or owned by the Concessionaire, or upon the rights of the Concessionaire to occupy the Concession Space, or upon the Concessionaire's Tenant Improvements and any other property thereon, or upon the Concessionaire's rights or operations hereunder. The Concessionaire shall have the right at its sole cost or expense to contest such taxes as may have been or may be levied, assessed or charged.

Liens. Concessionaire also shall not permit, create, or suffer to be created or to remain, any mechanic's, materialman's or any other lien to become attached or be foreclosed upon the Concession Space or improvements thereto, or any part or parcel thereof, by reason of any construction, services, work or labor performed or materials furnished by any mechanic or materialman. If any such lien shall at any time be filed, Concessionaire may contest the same in good faith. Notwithstanding such contest, Concessionaire shall, within fifteen (15) calendar days after the filing thereof, cause such lien to be released of record by payment, bond, or order of a court of competent jurisdiction. In the event Concessionaire fails to clear the record of any such lien within the aforesaid period, the City may remove said lien by paying the full amount thereof, or by bonding, or in any other manner the City deems appropriate, without investigating the validity thereof, and irrespective of the fact that Concessionaire may contest the propriety or the amount thereof. Thereafter Concessionaire shall pay the City the amount paid by the City in connection with the discharge of said lien. Upon demand, Concessionaire agrees to reimburse the City as provided in Section 5.09. Nothing contained in this Agreement shall be construed as consent on the part of the City to subject the Concession Space to any lien or liability.

Prompt Payment. Concessionaire agrees to furnish to the Manager, upon request, duplicate receipts or other satisfactory evidence showing the prompt payment by it of Social Security, unemployment insurance and worker's compensation insurance, and all required licenses and all taxes. Concessionaire further agrees to promptly pay when due all bills, debts and obligations incurred by it in connection with its operations hereunder and not to permit the same to become delinquent and to suffer no mortgage, judgment or execution to be filed against the Concession Space or improvements thereon which will in any way impair the rights of the City under this Agreement.

SECTION 10 –NON-COMPLIANCE AND VIOLATIONS

10.01. NONCOMPLIANCE

Manager's Objections. The Manager or the Manager's authorized representative shall have the right to make reasonable objections to Concessionaire's failure to create and maintain a vibrant first-class concession at the Airport as provided in Sections 5 and 7 and to operate its

business in a manner satisfactory to the Manager or the Manager's authorized representative. Concessionaire agrees to promptly discontinue or remedy any objectionable practice or condition within the correction period stated in any written notice issued by the Manager or Manager's authorized representative.

10.02. CUMULATIVE OR CONTINUOUS VIOLATIONS

Should Concessionaire violate the provisions of Sections 5 or 7 of this Agreement, the City may place the Concessionaire on notice to correct said violation or violations without declaring the violation an Event of Default, and in addition, collect liquidated damages as provided below.

With each notice, whether verbal or in writing, Concessionaire will be given a correction period in which to remedy the violation without further consequence. Except for a request for financial records by an authorized representative of the City, FAA, or Comptroller General, in which case the failure to produce the records within the time period allowed will trigger the imposition of liquidated damages. Otherwise, for each subcategory of Sections 5 or 7, Concessionaire will be allowed two written notices each calendar year before liquidated damages may be imposed in that same year. Beginning with the third written notice, and any written notices thereafter, liquidated damages may be assessed should Concessionaire fail to remedy the violation before the expiration of the correction period.

Concessionaire's Performance Obligations as Described in Sections 5 and 7	
Form of notice	Consequence
Pre-written Notice(s)	Verbal notification(s) issued by City to Concessionaire (correction period allowed)
1 st Written Notice	First written notice issued by City to Concessionaire (correction period allowed)
2 nd Written Notice	Second written notice issued by City to Concessionaire (correction period allowed)
3 rd Written Notice and thereafter	Third written notice by City to Concessionaire (correction period allowed). After the correction period, the Parties hereby agree that under the current circumstances a reasonable estimate of damages is One Hundred Dollars (\$100) per day per infraction for each whole or partial day until the violation is corrected.

For the purposes of this Section 10 only, the following definitions shall apply:

Correction Period. An amount of time required to become compliant with the Agreement for violations stated in pre-written or written notices issued by the City to the Concessionaire, either as mutually agreed between City and Concessionaire or in City's sole reasonable judgment taking into account the specific circumstances of the violation or violations and/or time allowed under previous verbal and written notices concerning the same or similar violations.

Pre-written Notice(s). Oral notifications of a Section 5 or Section 7 violation at the Concession Space delivered by the City to Concessionaire's ownership, management or its premises on-site management or staff. Pre-written notices may be in person or via telephone.

Written Notice. Notice of a Section 5 or Section 7 violation at the premises delivered by the City to Concessionaire's ownership, management or its premises on-site management or staff

via letter, email or by some other form as may be adopted from time to time by the City and delivered to Concessionaire at the notice address for Concessionaire specified in this Agreement.

Liquidated Damages. Concessionaire's failure to adhere to the operating and audit requirements set forth in this Agreement are reasonably anticipated to result in significant inconvenience to the public, adversely affect the overall business of the Airport and reduce the amount of Rent to be paid to the City. Additionally, City resources will be expended in dealing with violations of this Agreement by Concessionaire. The Parties hereby agree that total damages sustained by the City for violations of Sections 5 or 7 of this Agreement could be significant, but would be difficult to determine and to track. Therefore, the liquidated damages stated in this Agreement for violation of Concessionaire's performance and audit obligations are agreed to between the Concessionaire and the City to be reasonable amounts and reasonable estimates of the loss anticipated to be suffered or incurred by the City. Concessionaire, therefore, hereby agrees that imposition of these liquidated damages is fair and reasonable and Concessionaire agrees to pay to the City as Additional Rent the specified liquidated damage amounts immediately upon demand by the City. Liquidated damages stated in this Agreement shall continue for each full and each partial day for which the violation remains uncorrected beyond the correction date stated in the audit provisions of this Agreement or in any third and subsequent written notices as provided above.

Imposition of any of these pre-written notices, written notices and any liquidated damages assessed or collected shall not constitute a waiver of any other remedies available to the City due to Concessionaire's failure to meet its audit obligations or maintain Concessionaire's performance obligations as provided in Sections 5 and 7 of this Agreement.

Remedies Non-Exclusive. The City reserves the right, in the Manager's sole and absolute discretion, not to impose Liquidated Damages and instead to seek any other remedy available to the City as an Event of Default under Section 11, including termination of this Agreement.

The remedies provided in this Section 10 are in addition to all other rights and remedies that the City may have for a breach or violation of this Agreement. Nothing in this Section 10 shall be deemed to be a waiver by the City of any breach or violation of this Agreement, nor shall imposition of any of these sanctions be deemed to stop the City from terminating this Agreement or from asserting any other of its other rights or remedies under this Agreement, or at law or in equity. If any or all of these Sanctions are found to be unenforceable, then the unenforceable Sanction(s) will be discontinued, but the violations shall continue to be immediately covered by Section 11 and the remedies shall be as provided in Section 11.

SECTION 11 –DEFAULT, REMEDIES AND TERMINATION

11.01. DEFAULT

Event of Default. The occurrence of any of the following shall constitute an "Event of Default" (also referred to as a "Default").

Default in Rent. An Event of Default shall occur if Concessionaire fails to pay timely any Rent or Additional Rent when due and such failure or violation is not cured within ten (10) days after written notice by the City describing the nature of the breach or Default.

Cross-Default. The occurrence of an uncured breach, violation or default under any other agreement with the City at the Airport shall constitute an Event of Default.

Insurance or Performance Surety. An Event of Default shall occur if insurance or Performance Surety is canceled without City consent and not reestablished promptly after written notice by City to Concessionaire.

Bankruptcy/Insolvency. The Insolvency of Concessionaire shall be an Event of Default for which no notice or opportunity to cure need be given. For the purposes of this Agreement, and to the extent permitted by the United States Bankruptcy Code, "Insolvency" shall be deemed to include: (a) an assignment by Concessionaire for the benefit of creditors; (b) the filing by Concessionaire of a voluntary petition in bankruptcy; (c) dissolution; (d) the appointment of a receiver, trustee or liquidator of any or substantially all of the properties of Concessionaire and the receiver, trustee or liquidator is not discharged within forty- five (45) days; (e) the filing of an involuntary petition of bankruptcy and failure of Concessionaire to secure a dismissal of the petition within sixty (60) days after filing; and, (f) attachment of, or the levying of execution on this Concessionaire's interest, and failure of Concessionaire to secure discharge of the attachment or release of the levy of execution within forty-five (45) days.

Unapproved Transfers. An Event of Default shall occur if Concessionaire transfers its interest under this Agreement, without the prior written approval of the City, by reason of death, operation of law, assignment, sublease or otherwise, to any other person, entity or corporation.

Failure of Concessionaire's Obligation to Construct and Use Concession Space. An Event of Default shall occur if Concessionaire fails to timely submit plans and specifications, bonds and other preconstruction submittals, fails to promptly begin or timely complete construction of Improvements, fails to Open for Business to the public when construction is completed, or fails to occupy and use the Concession Space after construction is completed or fails to operate the concession.

Illegal Use. An Event of Default shall occur if Concessionaire uses, or gives its permission to any person to use, for any illegal purpose any portion of the Airport made available to Concessionaire for its use under this Agreement.

Abandonment. An Event of Default, for which no notice or opportunity to cure need be given, may be declared, at the City's option, if the City discovers that Concessionaire has abandoned, deserted or vacated the Concession Space.

Liens against City Property. If Concessionaire suffers any lien or attachment adverse to the interest of the City, including but not limited to mechanic's or materialman's liens to be filed against the Concession Space, or any lien or attachment to be filed against the Airport or the City's property because of any act or omission of Concessionaire, an Event of Default shall occur if such lien or attachment is not discharged or contested by Concessionaire in good faith by proper legal proceedings within 20 days after receipt of notice thereof by Concessionaire.

Material Misrepresentation. An Event of Default, for which no notice or opportunity to cure need be given, may be declared, at the City's option, if the City discovers that Concessionaire made a material misrepresentation to the City that induced the City to enter into this Agreement.

License or Franchise Agreement. If, during the Term (or any extended term) of this Agreement, the license or franchise agreement related to the Brand or trade name Concessionaire is authorized to operate at the Airport, is terminated, expires or is amended so that compliance with the amended provisions will cause Concessionaire to be in breach of its obligations under this Agreement, an Event of Default shall be deemed to have occurred.

Default in Other Covenants. An Event of Default shall occur if Concessionaire fails to keep, perform and observe any other promise or violates any term, covenant or condition of this Agreement, other than the payment of Rent, or Additional Rent, as described above, and such failure or violation is not cured within thirty (30) days after written notice by the City describing the nature of the failure or violation. This provision shall be complied with if (i) the violation is of such a nature that it cannot be completely cured within the thirty (30) day period, (ii) Concessionaire begins to perform whatever may be required to correct its failure to perform its obligation or to correct the violation within such thirty (30) day period and (iii) Concessionaire proceeds in good faith and continues such performance with all due diligence and without interruption, except for causes beyond its control, to effect the cure as soon as practical.

11.02. REMEDIES

Remedies on Default. Immediately upon the occurrence of an Event of Default, the City may, at its option, exercise any of the following rights and remedies in addition to any other rights and remedies provided elsewhere in this Agreement, or otherwise at law or in equity.

Right to Draw on Performance Surety. In an Event of Default, in the case of failure to pay Rent or Additional Rent or in the case of breach or violation of any other provision, including Concessionaire's obligations and duties under all general rules and regulations adopted by the City or the Manager for the management, operation and control of the Airport, after written notice by the City describing and giving Concessionaire an opportunity to cure the default, failure, breach or violation, the City may immediately, and without further notice to Concessionaire, draw upon the Performance Surety in any amount necessary to satisfy the damages sustained or reasonably expected to be sustained.

Elect to Continue and Enforce Agreement. The City may elect to allow this Agreement to continue in full force and effect without termination and to enforce all of City's rights and remedies hereunder, including without limitation the right to collect compensation as it becomes due together with Past Due Interest.

Termination of Agreement. Subject to Concessionaire's right to cure, if any, the City may terminate this Agreement and Concessionaire's right to possession immediately upon the occurrence of an Event of Default. Any notice to terminate may be given before or within the applicable cure period and may be included in a notice of failure of compliance. The City may cancel and terminate this Agreement and repossess the Concession Space, with or without process of law, and without liability for so doing, upon giving 30 days written notice to Concessionaire of its intention to terminate, at the end of which time all the rights hereunder of the Concessionaire shall terminate, unless the Default, which shall have been stated in such notice, is by its nature curable and shall have been cured within such 30 days.

Damages upon Termination. If City elects to terminate, Concessionaire shall be liable to City for all amounts owing at the time of termination, including but not limited to compensation due

plus interest thereon at the Past Due Interest Rate together with any other amount to fully compensate City for all loss of compensation, damages, and costs, including attorney's fees, caused by Concessionaire's failure to perform its obligations hereunder, or which in the ordinary course would likely result therefrom. Nothing in Sections 11.01 or 11.02 shall be construed to grant a right to Concessionaire to cure a default, which by its nature is not capable of being cured.

Re-Entry. Without accepting surrender and without prejudice to any remedies for damages or breach, the City may elect to reenter and take possession of the Concession Space or any part thereof, by suitable action or proceeding at law, or by force or otherwise, without being liable for indictment, prosecution or damages therefore, and may expel Concessionaire or any person claiming under Concessionaire, and remove all effects as may be necessary, to the end that the City may have, hold and enjoy the Concession Space. Such reentry shall not be construed as termination of this Agreement unless a written notice specifically so states; however, the City reserves the right to terminate the Agreement at any time after reentry.

Notwithstanding re-entry by the City, Concessionaire shall continue to be liable for all amounts due as compensation under this Agreement, on the dates specified and in such amounts as would be payable if default had not occurred. Upon expiration of the Term (or any extended term), or any earlier termination of the Agreement by the City, the City, having credited to the account of Concessionaire any amounts recovered through reletting, shall refund, without interest, any amount that exceeds the compensation, damages and costs payable by Concessionaire under this Agreement.

Reletting. Following re-entry, the City may relet the whole or any part of the Concession Space from time to time, either in the name of the City or otherwise, to such tenants, for such terms ending before, on or after the Expiration Date of this Agreement, at such rentals and upon such conditions (including financial concessions and free rent periods) as the City may determine to be appropriate. To the extent allowed under Colorado law, the City shall not be liable for refusal to relet the Concession Space, or, in the event of any such reletting, for failure to collect any Rent due upon such reletting; and no such failure shall operate to relieve Concessionaire of any liability under this Agreement or otherwise affect any such liability. The City may make such physical changes to the Concession Space as the City considers advisable or necessary in connection with any such reletting or proposed reletting, without relieving Concessionaire of any liability under this Agreement or otherwise affecting Concessionaire's liability. If the City has other vacant space, the City shall have no obligation to attempt to relet the Concession Space prior to leasing such other vacant space. The City shall not be required to attempt to relet the Concession Space to a potential lessee with whom the City has been negotiating for other space owned by the City or to whom the City has shown other space owned by the City. If the City has relet all or any part of the Concession Space for the period which otherwise would have constituted all, or any part, of the unexpired portion of the Term of this Agreement, the amount of Rent reserved on such reletting shall be deemed, prima facie, to be the fair and reasonable rental value for the part, or the whole, of the Concession Space so relet during the period of the reletting. Acts of maintenance, or preservation, or efforts to relet the Concession Space, or the appointment of a receiver upon initiative of the City to protect the City's interest under this Agreement, shall not constitute a termination of this Agreement or an acceptance of surrender of this Agreement.

Damages upon Re-Entry. Whether or not the City retakes possession or relets the Concession Space, the City shall have the right to recover damages immediately, without waiting until the due date of any future Rent or until the date fixed for expiration of this Agreement, which damages, shall include, but not be limited to the following: (a) all Rents lost, calculated through the Expiration Date, subject only to any duty to mitigate damages, if any; (b) all legal expenses and other related costs incurred by the City as a result of Concessionaire's Default; (c) all costs incurred by the City in restoring the Concession Space (or other damaged City property where damage was caused by Concessionaire) to good order and condition, or in remodeling, renovating or otherwise preparing the Concession Space for reletting, including, without limitation, removal and disposal of Concessionaire's Improvements or other property; (d) all taxes due or to become due under this Agreement; and, (e) all costs incurred by the City in reletting the Concession Space, including, without limitation, any advertising costs, brokerage commissions and the value of the City's staff time expended as a result of the Default. The present value of future amounts will be computed using a discount rate equal to the prime loan rate of major Colorado banks in effect on the date of trial.

11.03. REMEDIES CUMULATIVE

Remedies Cumulative and Nonexclusive. Each right and remedy in this Agreement shall be deemed cumulative and will be in addition to every other right or remedy in this Agreement, or existing at law or in equity, including, without limitation, suits for injunctive relief and specific performance. Such rights and remedies shall not be in lieu of or exclusive of each other and shall in no way affect any other remedy available at law or in equity. The exercise or beginning of the exercise, by the City of any such rights or remedies will not preclude the simultaneous or later exercise by the City of any other such rights or remedies. All such rights and remedies are nonexclusive. Nothing contained herein shall be construed to require the City to accept delinquent Rent, or delinquent Additional Rent. Acceptance of full or partial payment of delinquent Rent, or delinquent Additional Rent, shall not constitute a waiver of any of the City's other rights and remedies under this Section 11. The City may sue periodically to recover damages during the period corresponding to the remainder of the Term (or any extended term) of this Agreement, and no action for damages shall bar a later action for damages subsequently accruing.

11.04. ADMINISTRATIVE HEARING

Disputes arising out of this Agreement shall be resolved by administrative hearing before the Manager following the procedures outlined in Denver Revised Municipal Code Section 5-17; provided, that the City shall retain its right to obtain an order of eviction in accordance with applicable state law. It is further agreed that no cause of action shall be brought against the City until there has been full compliance with the terms of this paragraph. The Parties hereto agree that the Manager's determination resulting from said administrative hearing shall be final, subject only to the Concessionaire's right to appeal the determination under Colorado Rules of Civil Procedure, Rule 106.

11.05. WAIVERS

Non-Waiver of Rights – Default. No waiver of a breach or violation of this Agreement by the City of any of the terms, covenants, and conditions hereof to be performed, kept, and observed by the Concessionaire shall be construed as, or shall operate as, a waiver of any subsequent

breach or violation of any of the terms, covenants, or conditions herein contained, to be performed, kept, and observed by the Concessionaire

Non-Waiver of Rights – Partial Payment. No failure of City to insist upon the strict performance of a term, covenant or agreement contained in this Agreement, no failure by City to exercise any right or remedy under this Agreement, and no acceptance of full or partial payment during the continuance of any breach of this Agreement by Concessionaire shall constitute a waiver of any such term, covenant or agreement or a waiver of any such right or remedy or a waiver of any breach of this Agreement by Concessionaire.

SECTION 12 – DAMAGE, DESTRUCTION OR LOSS

12.01. DAMAGE TO OR DESTRUCTION OF CONCESSION SPACE

If Concessionaire's Improvements, or any portion thereof, are destroyed or damaged by fire, the elements or otherwise, the Concessionaire shall promptly remove all debris resulting from such damage to the Improvements and shall at its sole cost and expense repair and/or reconstruct the Improvements with due diligence whether or not the damage or destruction is covered by insurance in accordance with the plans and specifications for the Concession Space as they existed prior to such damage or according to the current needs of the Concessionaire as approved by the City. If Concessionaire fails to repair or replace damaged Improvements in accordance with a schedule agreed to by the City and Concessionaire, and provided that this Agreement has not been canceled, the City may make such repairs or replacement and upon demand, Concessionaire agrees to reimburse the City as provided in Section 5.09.

If the Concession Space, or any portion thereof, is destroyed or damaged by fire or otherwise to an extent which renders it unusable, City may rebuild or repair any portions of the building structure destroyed or damaged, and, if the cause was beyond the control of Concessionaire, the obligation of Concessionaire to pay the compensation hereunder shall abate as to such damaged or destroyed portions during the time they are unusable. If the City elects not to proceed with the rebuilding or repair of the building structure, it shall give notice of its intent within 90 days after the destruction or damage which the City will promptly provide to Concessionaire. Concessionaire may then, at its option, cancel and terminate this Agreement.

12.02. COOPERATION IN THE EVENT OF LOSS

If the City elects to rebuild, Concessionaire must replace all Improvements at its sole cost, in accordance with the Required Minimum Investment in November 2011 dollars and performance standards as set forth in **Exhibit X**. City and Concessionaire shall cooperate with each other in the collection of any insurance proceeds which may be payable in the event of any loss or damage.

12.03. LOSS OR DAMAGE TO PROPERTY

The City shall not be liable for any loss of property by theft or burglary from the Airport or for any damage to person or property on the Airport resulting from operating the elevators, or electric lighting, or water, rain or snow, which may come into or issue or flow from any part of the Airport, or from the pipes, plumbing, wiring, gas or sprinklers thereof or that may be caused by the City's employees or any other cause, and Concessionaire agrees to make no claim for any

such loss or damage at any time, except for any abatement of compensation or right to insurance proceeds provided for in this Section 12.

12.04. MUTUAL WAIVER; INSURANCE COVERAGE

City and Concessionaire each waive any and every claim for recovery from the other for any and all loss of or damage to the Concession Space or to the contents thereof, which loss or damage is covered by valid and collectible fire and extended insurance policies, to the extent that such loss or damage is recoverable under such insurance policies. Since this mutual waiver will preclude the assignment of any such claim by subrogation or otherwise to an insurance company or any other person, Concessionaire agrees to give to each insurance company which has issued, or may issue, to the Concessionaire policies of fire and extended coverage insurance, written notice of the terms of this mutual waiver, and to have such insurance policies properly endorsed, if necessary, to prevent the invalidation of the insurance coverage by reason of this waiver.

Concessionaire Caused Damage. If Concessionaire caused the damage described in this Section 12, Concessionaire shall pay for all of the full rebuilding costs, except to the extent of the waiver of subrogation set forth in this Section 12 and Rent shall not be reduced.

Limits of the City's Obligations Defined. It is understood that, in the application of this Section 12, the City's obligations shall be limited to the repair or reconstruction of the Concession Space to a condition with utilities stubbed into the Concession Space suitable for Concessionaire to re-build. Redecoration, Improvements, Trade Fixtures, inventory and replacement of all of Concessionaire's furniture, equipment, inventory and supplies shall be the sole responsibility of Concessionaire and any such redecoration and refurbishing/re-equipping shall be of equivalent quality to that originally installed under the terms of this Agreement.

No Duty to Protect. Protection against loss by fire or other casualty to any of the contents of the Concession Space shall not, at any time, be an obligation of the City.

12.05. RELEASE

Concessionaire agrees that the City shall not be liable to Concessionaire for any injury to or death of any of the Concessionaire's agents, representatives or employees or of any other person or for any damage to any of Concessionaire's property or loss of revenue caused by any third person in the maintenance, construction, or operation of facilities at the Airport, or caused by any third person using the Airport, or caused by any third person navigating any aircraft on or over the Airport, whether such injury, death or damage is due to negligence or otherwise.

SECTION 13 – PROMOTIONAL PROGRAM

13.01. JOINT MARKETING FUND

A. The City shall provide or cause to be provided a central marketing and promotional fund which, in the City's sole judgment, will serve to promote overall service, retail and food and beverage concessions at the Airport. The fund shall be known as the "Joint Marketing Fund." Concessionaire shall contribute during each month, as Concessionaire's share of the Joint Marketing Fund, a Marketing Assessment in an amount equal to the percent

of monthly Gross Revenues stated on the Summary Page. This amount is payable to the City on the 10th day of the second month and each succeeding month following the Rent Commencement Date. If Concessionaire is unable to calculate actual Gross Revenues in time to make the required payment to the Joint Marketing Fund, the payment may be made based on an estimate of Gross Revenues. Any and all such estimated payments shall be adjusted as of the end of each six (6) month period of each year. Within 30 days of the end of each six (6) month period, Concessionaire shall send a report to the City reconciling estimated and actual Gross Revenues and showing any over or underpayments to the Joint Marketing Fund. A check for any underpayments must accompany the reconciliation. All overpayments will be credited to the next payment(s) due to Concessionaire.

B. The City shall not be obligated to expend more for promotions and advertising than is actually collected from Concessionaires. Any promotional services and personnel so provided shall be under the exclusive control and supervision of the City. The City reserves the right at any time to terminate the Joint Marketing Fund and thereafter, continue to provide marketing and promotional services until the balances remaining in the Fund are exhausted.

13.02. PREMIUM VALUE CONCESSIONS PROGRAM

A. The Department of Aviation has created a "Premium Value Concessions Program" ("PVC Program") described in the Airport Rules and Regulations (the "PVC Rules") to reward certain categories of concessionaires which maintain the high performance standards defined in the PVC Rule.

B. Concessionaire acknowledges that it is required by this Agreement and the PVC Rules to participate as a single location in the PVC Program. The major and minor categories and square footage relating to Concessionaire's participation in the PVC Program are listed on the Summary Page. Concessionaire agrees that upon written notice from the Manager, Concessionaire shall contribute Concessionaire's prorated share of the cost of PVC Program which will be calculated in accordance with the methodology set forth in the PVC Rules. Concessionaire's contribution shall be payable to the City in advance, without setoff, deduction, prior notice or abatement commencing on the first day of every month following the City's notification and continuing until the Joint Marketing Fund generates One Million Dollars in annual revenue.

C. The City shall not be obligated to expend more for the PVC Program than is actually collected from Concessionaires. All services related to the PVC Program and all personnel engaged by the City to provide services related to the PVC Program, including the services of a Third Party Administrator, as that term is defined in the PVC Rules shall be under the exclusive control and supervision of the City.

D. Under certain circumstances described in the PVC Rules, the Manager, in her sole and absolute discretion, may terminate the PVC Program upon 30 days notice to Concessionaire.

E. In the event of a conflict between any provision of the PVC Rules and this Agreement, the provisions of this Agreement including the Summary Page, exhibits and appendices appended hereto shall govern.

SECTION 14 – MISCELLANEOUS PROVISIONS

14.01. AGREEMENT BINDING UPON SUCCESSORS

This Agreement, subject to the provisions of the Section entitled "Assignment," shall be binding upon and shall inure to the heirs, personal representatives, successors and assigns of the City and Concessionaire where permitted by this Agreement. The term "Concessionaire" shall include an assignee or sub lessee from the Concessionaire on any assignment or sublease approved by the City, but no such assignment or sublease shall be approved or shall have any effect unless the Concessionaire and its proposed assignees or sub lessee shall thereafter be jointly bound thereby as the Concessionaire hereunder. Moreover, in the event the Concessionaire is authorized to assign, or sublet to, or contract with, a third party to sell any item or perform or provide any service, Gross Revenues as used herein shall include the total gross revenues generated by the performance or sale by such third party, and not the amount received by the Concessionaire from such third party.

14.02. AGREEMENT MADE IN COLORADO; VENUE

This Agreement shall be deemed to have been made in and shall be construed in accordance with the laws of the State of Colorado and the Charter and Ordinances of the City and County of Denver and the Parties agree that venue for any action arising from this Agreement shall be in the District Court in and for the City and County of Denver. The Concessionaire agrees that any and all notices, pleadings and process may be made by serving two copies of the same upon the Colorado Secretary of State, State Capitol, Denver, Colorado, and by mailing by return mail an additional copy of the same to the Concessionaire at the address shown herein; that said service shall be considered as valid personal service, and judgment may be taken if, within the time prescribed by Colorado law or Rules of Civil Procedure, appearance, pleading or answer is not made.

14.03. AGREEMENTS WITH THE UNITED STATES

This Agreement is subject and subordinate to the terms, reservations, restrictions and conditions of any existing or future agreements between the City and the United States, the execution of which has been or may be required as a condition precedent to the transfer of federal rights or property to the City for Airport purposes and the expenditure of federal funds for the extension, expansion or development of the Airport or airport system. The provisions of the attached Appendices 1, 2, 3 and 10 are incorporated herein by reference.

14.04. RIGHT TO DEVELOP AIRPORT

Concessionaire agrees that the City reserves the right to further develop or improve the Airport and all landing areas and taxiways as the City may see fit, regardless of the desires or views of Concessionaire and without any interference or hindrances from Concessionaire.

14.05. AGREEMENT SUBJECT TO AVIATION PRIORITY

Concessionaire's right to use the Concession Space for the purposes as set forth in this Agreement shall be secondary to, and subordinate to, the operation of the Airport. Concessionaire acknowledges that because of the location of the Concession Space at the

Airport, noise, vibrations, fumes, debris and other interference with the Permitted Use will be caused by Airport operations. Concessionaire hereby waives any and all rights or remedies against the City arising out of any noise, vibration, fumes, debris and/or interference that is caused by the operation of the Airport. The City specifically reserves for itself, and for the public, a right of flight for the passage of aircraft in the airspace above the surface of the Airport together with the right to cause in said airspace such noise, vibration, fumes, debris, and other interference as may be inherent in the present and future operation of aircraft.

14.06. MODIFICATIONS REQUIRED BY FAA

In the event that the FAA or its successors requires modifications or changes in this Agreement as a condition precedent to the granting of funds for the improvement of the Airport, or otherwise, Concessionaire agrees to consent to such amendments, modifications, revisions, supplements, or deletions of any of the terms, conditions, or requirements of this Agreement as may be reasonably required to satisfy the FAA requirements, subject to the provisions of this Agreement.

14.07. ASSIGNMENT AND SUBLEASE

Concessionaire shall not assign, transfer, sublease, pledge, hypothecate, surrender, or otherwise encumber (collectively "Transfer"), or dispose of this Agreement or any interest created by this Agreement, or any interest in any portion of the same, nor grant any license or concession hereunder, or permit any other person or persons, company or corporation to occupy the Concession Space, without first obtaining the written consent of the Manager, which consent may be granted or denied in the sole and absolute discretion of the Manager. Any attempt by the Concessionaire to in any way Transfer its interest in this Agreement, in whole or in part, directly or indirectly (including any attempt to transfer the ownership of the equity or voting interest in the stock if Concessionaire is a corporate entity or the ownership interest in such other entity or control of Concessionaire or Concessionaire's operations through sale, exchange, merger, consolidation or other such Transfer), without the prior written consent of the Manager shall, at the option of said Manager, automatically terminate this Agreement and all rights of the Concessionaire hereunder. These restrictions on Transfer shall also apply to assignment of activities, uses, privileges, and obligations authorized under this Agreement.

The City's consent to a Transfer shall not include consent to enlarge the Term or modify other material provisions of this Agreement. The City's consent to a Transfer shall not constitute a release of liability of Concessionaire pursuant to the requested Transfer. The City's consent to one such Transfer shall not be deemed a consent to subsequent Transfers.

14.08. BOND ORDINANCES

This Agreement is in all respects subject and subordinate to any and all City bond ordinances applicable to the Airport and airport system and to any other bond ordinances, which should amend, supplement or replace such bond ordinances. The Parties to this Agreement acknowledge and agree that all property subject to this Agreement which was financed by the net proceeds of tax-exempt bonds is owned by the City, and Concessionaire agrees not to take any action that would impair, or omit to take any action required to confirm, the treatment of such property as owned by the City for purposes of Section 142(b) of the Internal Revenue Code of 1986, as amended. In particular, the Concessionaire agrees to make, and hereby

makes, an irrevocable election (binding on itself and all successors in interest under this Agreement) not to claim depreciation or an investment credit with respect to any property subject to this Agreement which was financed by the net proceeds of tax-exempt bonds and shall execute such forms and take such other action as the City may request in order to implement such election.

14.09. FORCE MAJEURE

Neither Party hereto shall be liable to the other for any failure, delay or interruption in the performance of any of the terms, covenants or conditions of this Agreement due to causes beyond the control of that Party, including without limitation strikes, boycotts, labor disputes, embargoes, shortages of materials, acts of God, acts of the public enemy, acts of superior governmental authority, weather conditions, floods, riots, rebellion, sabotage or any other circumstance for which such Party is not responsible or which is not in its power to control. A lack of funds, however, will never be deemed beyond a Party's power to control, but in no event shall this paragraph be construed so as to allow Concessionaire to reduce or abate its obligation to pay the MAG or Percentage Compensation Fee herein, or any other compensation due hereunder.

14.10. INCONVENIENCES DURING CONSTRUCTION

Concessionaire recognizes that from time to time during the Term (or any extended term) of this Agreement, it may be necessary for City to commence or complete extensive programs of construction, expansion, relocation, maintenance and repair in order that the Airport and its facilities may be maintained, improved, and operated in accordance with any present or future master layout plan, and that such construction, expansion, relocation, maintenance and repair may inconvenience the Concessionaire in its operation at the Airport. Concessionaire agrees that no liability shall attach to City, its officers, agents, employees, contractors, subcontractors and representatives by way of such inconveniences, and Concessionaire waives any right to claim damages or other consideration therefrom.

14.11. MASTER PLAN

Concessionaire agrees that no liability shall attach to the City, its officers, agents and employees by reason of any efforts or action toward implementation of any present or future master layout plan for the Airport, and waives any right to claim damages or other consideration arising therefrom.

14.12. FUTURE CONCESSIONS PLANNING

Concessionaire agrees that no liability shall attach to the City, its officers, agents and employees by reason of any efforts or action toward implementation of any present or future planning for the Airport's concessions program, and waives any right to claim damages or other consideration arising therefrom.

14.13. NONDISCRIMINATION

In connection with the performance of work under this Agreement, Concessionaire agrees not to refuse to hire, discharge, promote or demote, or to discriminate in matters of compensation

against any person otherwise qualified, solely because of race, color, religion, national origin, gender, age, military status, sexual orientation, marital status, or physical or mental disability, and Concessionaire further agrees to insert the foregoing provision in all subcontracts hereunder.

14.14. NOT PARTNERSHIP

It is understood and agreed by and between the Parties hereto that the status of the Concessionaire shall be that of an independent contractor. Notwithstanding the provisions herein for payment by Concessionaire to City of sums based upon a percentage of Gross Revenues, it is further expressly understood and agreed that the City shall not be construed by a third party or held by Concessionaire to be a partner, associate or joint venture partner of Concessionaire in the conduct of its business. Concessionaire shall at all times have the status of an independent contractor and is not intended nor shall it be construed that the Concessionaire, its employees or sub contractors are employees or officers of the City under Chapter 18 of the Revised Municipal Code or for any purpose whatsoever with any right or City authority to impose tort or contractual liability upon the City. The Concessionaire has no authority to bind the City on any contractual matters. Final approval of all contractual matters that obligate the City must be by the City as required by Charter and Ordinance.

14.15. NOTICES

All notices required to be given to the City or Concessionaire hereunder shall be in writing and sent by certified mail, return receipt requested, as follows:

to City:	Manager of Aviation Denver International Airport Airport Office Building, 9th Floor 8500 Peña Boulevard Denver, CO 80249-6340
with a copy to:	Deputy Manager of Aviation, Commercial Denver International Airport Airport Office Building, 9th Floor 8500 Peña Boulevard Denver, CO 80249-6340
to Concessionaire:	At the address and to the attention of the person so designated on the Summary Page.

Either Party hereto may designate in writing from time to time the address of substitute or supplementary persons within the State of Colorado to receive such notices. The effective date of service of any such notice shall be the date such notice is mailed or delivered to the intended Party.

14.16. PARAGRAPH HEADINGS

The paragraph headings herein are for convenience in reference only and are not intended to define or limit the scope of any provision of this Agreement.

14.17. PATENTS AND TRADEMARKS

Concessionaire represents that it is the owner of or fully authorized to use any and all services, processes, machines, articles, marks, names or slogans used by it in its operations under this Agreement. Concessionaire will not utilize any protected patent, trademark or copyright, including any patents, trademarks or copyrights owned by the City, in its operations under this Agreement unless it has obtained proper permission and all releases and other necessary documents. Concessionaire agrees to save and hold harmless the City, its officers, employees, agents and representatives from any loss, liability, expense, suit or claim for damages in connection with any actual or alleged infringement of any patent, trademark or copyright arising from any alleged or actual unfair competition or other similar claim arising out of the operations of Concessionaire under this Agreement.

14.18. COLORADO OPEN RECORDS ACT

A. The Concessionaire acknowledges that the City is subject to the provisions of the Colorado Open Records Act, Colorado Revised Statutes §24-72-201 et seq., and all documents prepared or provided by Concessionaire under this Agreement may be subject to the provisions of the Colorado Open Records Act. Any other provision of this Agreement notwithstanding, including exhibits, attachments and other documents incorporated into this Agreement by reference, all materials, records and information provided by the Concessionaire to the City shall be considered confidential by the City only to the extent provided in the Open Records Act and the Concessionaire agrees that any disclosure of information by the City consistent with the provisions of the Open Records Act shall result in no liability of the City. The Concessionaire agrees that it will fully cooperate with the City in the event of a request for disclosure of such documents or a lawsuit arising under such act for the disclosure of any documents or information, which the Concessionaire asserts, is confidential and exempt from disclosure.

B. In the event of a request to the City for disclosure of such information, time and circumstances permitting, the City will make a good faith effort to advise the Concessionaire of such request in order to give the Concessionaire the opportunity to object to the disclosure of any of material the Concessionaire may consider confidential, proprietary or otherwise exempt from disclosure. In the event of the filing of a lawsuit to compel disclosure, the City will tender all such material to the court for judicial determination of the issue of disclosure and the Concessionaire agrees it will either intervene in such lawsuit to protect materials the Concessionaire does not wish disclosed, or waive any claim of privilege or confidentiality. If the Concessionaire chooses to intervene in such a lawsuit and oppose disclosure of any materials, the Concessionaire agrees to defend, indemnify, and save and hold harmless the City, its officers, agents, and employees, from any claim, damages, expense, loss or costs arising out of the Concessionaire's intervention including, but not limited to, prompt reimbursement to the City of all reasonable attorney fees, costs and damages that the City may incur directly or may be ordered to pay by such court.

14.19. SECURITY

Security Procedures. Concessionaire shall submit to the City for review, at least 30 days prior to the Required Opening Date, written operating and security procedures for its operations hereunder. Concessionaire shall revise such operating and security procedures as necessary to obtain City approval of them.

Compliance with Airport Security. It is a material requirement of this Agreement that the Concessionaire shall comply with all rules, regulations, written policies and authorized directives from the City and/or the Transportation Security Administration with respect to Airport security. Concessionaire shall cause its officers, contractors, agents and employees to comply with any and all existing and future security regulations adopted by the City or the Transportation Security Administration ("TSA"), including 49 CFR Subtitle B, Chapter XII, as amended from time to time. Concessionaire understands and acknowledges that its ability to remain open and sell the items it is authorized to sell under this Agreement is subject to changes in alert status as determined by TSA. Violation by Concessionaire or any of its employees of any rule, regulation or authorized directive from the City or the Transportation Security Administration with respect to Airport Security shall constitute a material breach of this Agreement and any person who violates such rules may be subject to revocation of his/her access authorization. Concessionaire will reimburse the City, in full, for any fines or penalties levied against the City for security violations as a result of any actions on the part of Concessionaire, its agents, contractors, suppliers, guests, customers or employees and for any attorney fees or related costs paid by the City as a result of any such violation. The Concessionaire shall return to the City at the expiration or termination of this Agreement, or upon demand by the City all access keys or access badges issued to it for any area of the Airport, whether or not restricted. If the Concessionaire fails to do so, the Concessionaire shall be liable to reimburse the City for all the City's costs for work required to prevent compromise of the Airport security system. The City may withhold funds in the amount of such costs from any amounts due and payable to the Concessionaire under this Agreement. The security status of the Airport is subject to change without notice. If the security status of the Airport changes at any time during the Term (or any extended term) of this Agreement, the Concessionaire shall take immediate steps to comply and assist its Operators with compliance with security modifications which occur as a result of the changed status. The Concessionaire may at any time obtain current information from the Airport Security Office regarding the Airport's security status in relation to the Concessionaire's operations at the Airport.

14.20. SEVERABILITY

If any part, portion or provision of this Agreement or application thereof shall be found or declared null, void, or unenforceable for any reason whatsoever by any court of competent jurisdiction or any governmental agency having applicable authority, only such part, portion, or provision shall be affected thereby. The validity of the remaining portions or provisions or application thereof shall not be affected if the intent of the Parties can be fulfilled and all other parts, portions and provisions of this Agreement shall remain in full force and effect. No oral representations or other agreements have been made except as specifically stated in this Agreement.

14.21. AUTHORITY TO ENTER INTO AGREEMENT

The person(s) signing this Agreement represents and warrants that s/he possesses the legal authority, pursuant to any proper, appropriate and official motion, resolution or action passed or taken, to enter into this Agreement. Each person signing and executing this Agreement on behalf of Concessionaire represents and warrants that s/he has been fully authorized by Concessionaire to execute this Agreement on behalf of Concessionaire and validly and legally bind Concessionaire to all the terms, performances and provisions of this Agreement. The City shall have the right, in its sole discretion, to either temporarily suspend or permanently terminate

this Agreement if there is a dispute as to the legal authority of either Concessionaire or the person signing the Agreement to enter into this Agreement.

14.22. NO CONSTRUCTION AGAINST DRAFTING PARTY

This Agreement is the result of arms length negotiations between the City and Concessionaire and each of the Parties acknowledge that they and their respective counsel have had the opportunity to review and revise this Agreement. Therefore, the Parties agree that any ambiguity in this Agreement shall not be construed against any Party merely because this Agreement or any of its provisions were prepared by a particular Party.

14.23. THIRD PARTIES

The enforcement of the terms and conditions of this Agreement and all rights of action relating to such enforcement, shall be strictly reserved to the City and the Concessionaire, and nothing contained in this Agreement shall be deemed or construed to confer upon or grant to any third party or parties (except Parties to whom the Concessionaire may assign this Agreement in accordance with the terms hereof, and except any successor to the City) any right to claim damages or to bring any suit, action or other proceeding against either the City or the Concessionaire because of any breach hereof or because of any failure to comply with of any of the terms, covenants, agreements and conditions herein. It is the express intention of the City and the Concessionaire that any other person other than the City or the Concessionaire receiving any benefits from this Agreement shall be deemed to be incidental beneficiaries only.

14.24. USE, POSSESSION OR SALE OF ALCOHOL OR DRUGS

Concessionaire, its officers, agents and employees shall cooperate and comply with the provisions of the Federal Drug-Free Workplace Act of 1988 and Denver Executive Order No. 94, or any successor thereto, concerning the use, possession or sale of alcohol or drugs. Except as otherwise may be provided herein, Concessionaire shall also prohibit consumption of alcohol within the Concession Space. Violation of these provisions or refusal to cooperate with implementation of the policy can result in the City's barring Concessionaire from City facilities or participating in City operations.

14.25. CITY SMOKING POLICY

Concessionaire agrees that it will prohibit smoking by its employees and the public in the Concession Space and will not sell or advertise tobacco products. Concessionaire acknowledges that smoking is not permitted in Airport buildings and facilities except for designated smoking lounges. Concessionaire and its officers, agents and employees shall cooperate and comply with the provisions of the City's Executive Order No. 99 dated December 1, 1993, Executive Order No. 13 dated July 31, 2002, the provisions of Denver Revised Municipal Code, §§ 24-301 to 317 et. seq., and the Colorado Clean Indoor Air Act, C.R.S. §§ 25-14-201 et. seq.

14.26. WAIVER OF CLAIMS

Each Party hereby waives any claim against the other Party for consequential, special or punitive damages, including, without limitation, loss of anticipated profits caused by any suit or

proceedings attacking the validity of this Agreement, or any part of this Agreement, or by any judgment or award in any suit declaring this Agreement null, void, or voidable, or delaying this Agreement or any part of it being carried out or the enforcement of this Agreement.

14.27. NUMBER OR GENDER

The use herein of the singular shall include the plural, and use of the masculine, feminine, or neutral genders shall include all others.

14.28. JOINT AND SEVERAL LIABILITY

If Concessionaire is a partnership or other business organization, the members of which are subject to personal liability, the liability of each such member shall be deemed to be joint and several.

14.29. BROKER'S COMMISSION

Concessionaire represents and warrants that it has not caused nor incurred any claims for brokerage commissions or finder's fees in connection with the execution of this Agreement, and Concessionaire shall indemnify and hold the City harmless against and from all liabilities arising from any such claims caused or incurred by it (including without limitation, the cost of attorney fees in connection therewith).

14.30. NO LIMIT ON CITY'S POWERS

Nothing in this Agreement shall limit, in any way, the power and right of the City to exercise its governmental rights and powers, including its powers of eminent domain.

14.31. WAR OR NATIONAL EMERGENCY

During the time of war or national emergency, the City shall have the right to lease the Airport or any part thereof to the United States Government for military use, and if any such lease is executed, the provisions of this Agreement insofar as they are inconsistent with this Agreement to the Government shall be suspended, and in that event, a just proportionate part of the MAG hereunder shall be abated.

14.32. SURVIVAL OF CERTAIN CONTRACT PROVISIONS

The Parties understand and agree that all terms and conditions of this Agreement, (such as the indemnity agreement set forth herein) which by reasonable implication contemplate continued performance or compliance beyond the termination of this Agreement (by expiration of the Term (or any extended term) or otherwise) shall survive the expiration or earlier termination of this Agreement and shall continue to be fully enforceable as provided herein.

14.33. AGREEMENT AS COMPLETE INTEGRATION; AMENDMENTS

The City and Concessionaire each warrant and represent to each other that this Agreement constitutes their legal, valid and binding obligation and that the provisions herein including all Exhibits and other documents incorporated by reference, contain the entire agreement and are intended as the complete integration of all understandings between the Parties. No prior or

contemporaneous addition, deletion, or other amendment hereto shall have any force or effect whatsoever, unless embodied in a written amendment to this Agreement properly executed by the Parties. No subsequent novation, renewal, addition, deletion, or other amendment hereto shall have any force or effect unless embodied in a written amendment or other agreement executed with the same formality as this Agreement. This Agreement and any subsequent written amendments or other alteration not requiring formal amendment as set forth in this Agreement, including but not limited to **Exhibit D** as modified from time to time, form the entire agreement between the parties and are fully binding on the Parties, their successors and assigns. No oral representations by any officer, official, employee or agent of the City and no other agreement at variance with the terms and conditions of this Agreement herein have been made.

14.34. FINAL APPROVAL; COUNTERPARTS

This Agreement, which is expressly subject to, and shall not be or become effective or binding on the City until approved by the City Council, and fully executed by all signatories of the City and County of Denver, may be executed in two or more counterparts, each of which will be deemed an original signature page to this Agreement.

14.35. ELECTRONIC SIGNATURES AND ELECTRONIC RECORDS

Concessionaire consents to the use of electronic signatures by the City. The Agreement, and any other documents requiring a signature hereunder, may be signed electronically by the City in the manner specified by the City. The Parties agree not to deny the legal effect or enforceability of the Agreement solely because it is in electronic form or because an electronic record was used in its formation. The Parties agree not to object to the admissibility of the Agreement in the form of an electronic record, or a paper copy of an electronic document, or a paper copy of a document bearing an electronic signature, on the ground that it is an electronic record or electronic signature or that it is not in its original form or is not an original.

[SIGNATURE PAGES FOLLOW]

IN WITNESS WHEREOF, the parties have caused this agreement to be executed at Denver, Colorado as of the date indicated on the city signature page.

Contract Control Number: 201102971

Vendor Name: HOST-CTI DEN F&B II, LLC

Host-CTI DEN F&B II, LLC ^{F&B}

By

HOST INTERNATIONAL, INC.

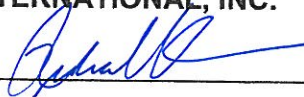
By: 

Name: RICHARD KUNKLE
(please print) Authorized Signatory

Title: _____
(please print)

ATTEST:

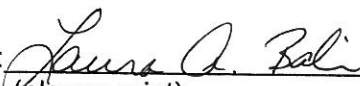
Name: 
(please print)

Laura A. Babin
Secretary

Title: _____
(please print)

TECHNOLOGY (SK)
CIVIL TECHNOLOGIES, INC.

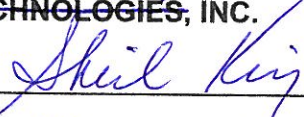
By: 

Name: SHEILA KING
(please print)

Title: PRESIDENT
(please print)

Contract Control Number:

Vendor Name:

IN WITNESS WHEREOF, the parties have set their hands and affixed their seals at Denver, Colorado as of

SEAL

CITY AND COUNTY OF DENVER

ATTEST:

By _____

APPROVED AS TO FORM:

REGISTERED AND COUNTERSIGNED:

By _____

By _____

By _____



EXHIBIT A
CONCESSION SPACE PLAN

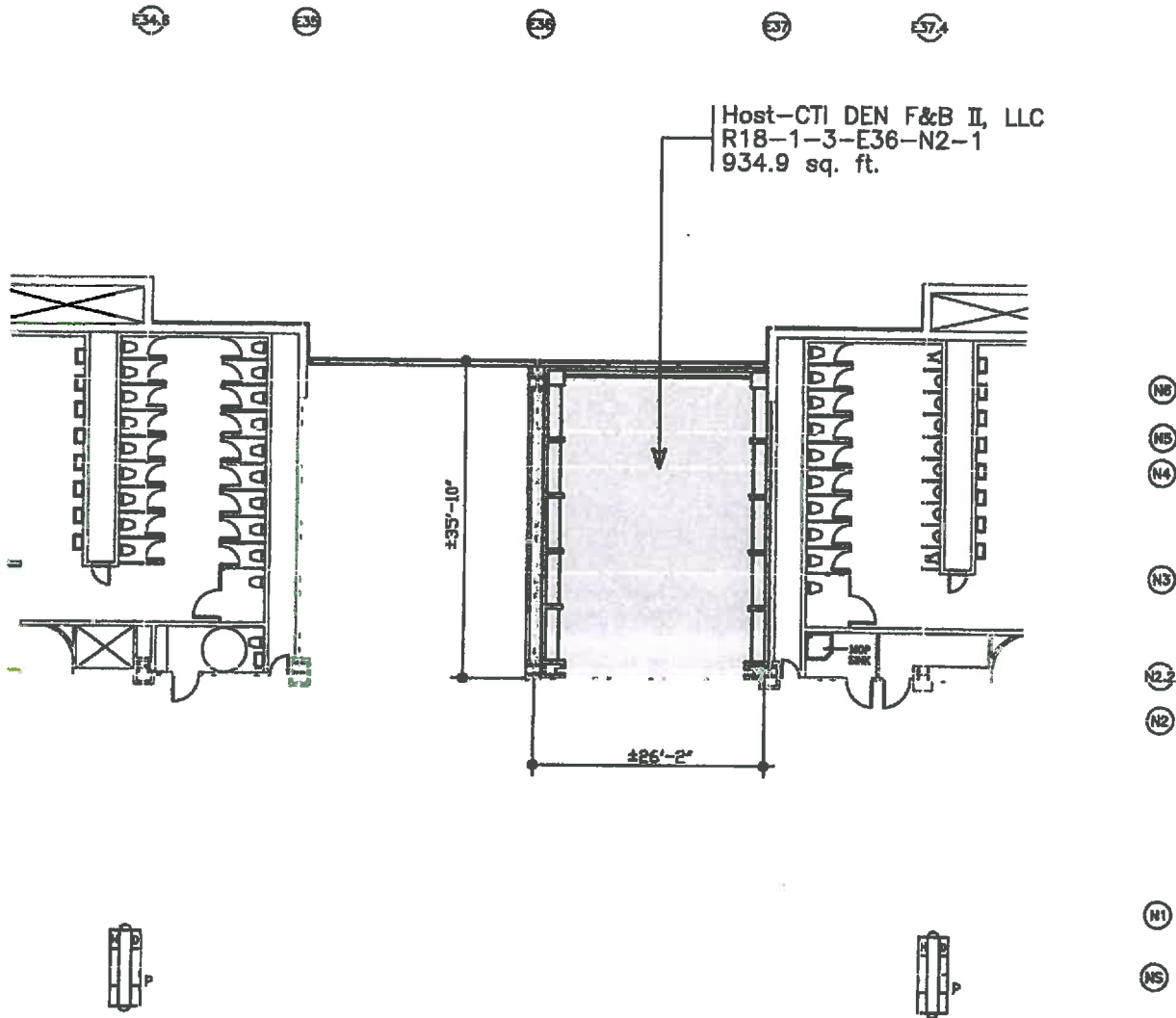

Host-CTI DEN F&B II, LLC
R18-1-3-E36-N2-1
934.9 sq. ft.

- CONC. WALL (BY CITY)
- STUD/GYPSUM WALL (BY CITY)
- GLASS WALL (BY CITY)
- TENANT LEASE LINE

(H) (□) COLUMNS
NIC = Not Included
(In Lease or Sq. Ft. Calc.)

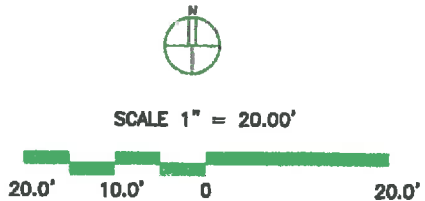

Ronald Horn
MANAGER OF DESIGN

NOTE:
This exhibit depicts only approximate dimensions and square footage of leased area based upon planning data and is not intended to show dimensions for construction details.

 KEY PLAN CONCOURSE B		REVISED <hr/> <hr/> <hr/>	DENVER INTERNATIONAL AIRPORT Request For Proposal Concourse B Conc. Level Host-CTI DEN F&B II, LLC dba Cru Wine and Food Bar
		CC#: host	DATE: 09/16/11

EXHIBIT B

DISADVANTAGED BUSINESS ENTERPRISE PARTICIPATION

HOST-CTI DEN F&B II, LLC

SECTION 1 – GENERAL. Except as the context otherwise requires and unless otherwise expressly provided herein, the capitalized terms in this *Exhibit* to the Agreement shall have the same meaning as any similarly capitalized terms defined in the Agreement or in any *Exhibit* thereto.

SECTION 2 – ACDBE OBLIGATION. This agreement is subject to the requirements of the U.S. Department of Transportation's Regulations, 49 CFR Part 23. The Concessionaire agrees that it will not discriminate against any business owner because of the owner's race, color, national origin, or sex in connection with the award or performance of any concession agreement, management contract, or subcontract, or other agreement covered by 49 CFR Part 23.

SECTION 3 – OTHER AGREEMENTS. The Concessionaire agrees to include the above statements in any subsequent concession agreement or contract covered by 49 CFR Part 23, that it enters and cause those businesses to similarly include the statements in further agreements.

EXHIBIT C

INSURANCE CERTIFICATE

PLEASE GIVE THIS FORM TO YOUR INSURANCE AGENT FOR COMPLETION.

**CITY AND COUNTY OF DENVER
CERTIFICATE OF INSURANCE FOR DEPARTMENT OF AVIATION**

Original COI

Advice of Renewal

Change

Party to Whom this Certificate is Issued:

Name and Address of Insured:

CITY AND COUNTY OF DENVER
Manager of Aviation
Denver International Airport
8500 Pena Boulevard, Room 8810
Denver CO 80249

CONTRACT NAME & NUMBER TO WHICH THIS INSURANCE APPLIES: Food and Beverage Concession @ DIA

I. MANDATORY COVERAGE

WC-1 Colorado Workers' Compensation and Employer Liability Coverage

Coverage	Minimum Limits of Liability (In Thousands)	Policy No. & Company	Policy Period
COLORADO Workers' Compensation Employer's Liability	WC Statutory Limits \$100, \$500, \$100 Limits		

Any Policy issued under this section must contain, include or provide for the following:

1. All States Coverage or Colorado listed as a covered state for the Workers' Compensation
2. Waiver of Subrogation and Rights of Recovery against the City and County of Denver (the "City"), its officers, officials and employees.

CGL-1 Commercial General Liability Coverage

Coverage	Minimum Limits of Liability (In Thousands)	Policy No. & Company	Policy Period
Commercial General Liability (coverage at least as broad as that provided by ISO form CG0001 or equivalent)	Each Occurrence: \$1,000 General Aggregate Limit: \$2,000 Products-Completed Operations Aggregate Limit: \$2,000 Liquor Liability \$2,000 Personal & Advertising Injury: \$1,000 Fire Damage Legal - Any one fire \$50 (\$300 if a City facility is leased)		

Any Policy issued under this section must contain, include or provide for the following:

1. City, its officers, officials and employees as additional insureds, per ISO form CG2010 or equivalent.
2. Coverage for defense costs of additional insureds outside the limits of insurance, per CG0001.
3. Liability assumed under an Insured Contract (Contractual Liability).
4. The full limits of coverage must be dedicated to apply to this project/location, per ISO form CG2503 or equivalent.
5. Waiver of Subrogation and Rights of Recovery, per ISO form CG2404 or equivalent.
6. If event involves racing, demolition derby/rodeo or air meets, then Exclusion H and Exclusion G must be deleted or a separate policy provided for these types of events.
7. If liquor is to be sold or distributed, then Liquor Liability, with City as an additional insured is required.
8. Separation of Insureds Provision required
9. Endorsement showing General Aggregate Limit Applies Per: Policy ___ Project ___ Location X ___, if applicable

BAL-1. Business Automobile Liability Coverage

Coverage	Minimum Limits of Liability (In Thousands)	Policy No. & Company	Policy Period
Business Automobile Liability (coverage at least as broad as ISO form CA 0001)	Combined Single Limit \$1,000		

Any Policy issued under this section must contain, include or provide for the following:

1. Symbol 1, coverage for any auto. If no autos are owned, Symbols 8 & 9, (Hired and Non-owned) auto liability.
2. If this contract involves the transport of hazardous cargo such as fuel, solvents or other hazardous materials may occur, then Broadened Pollution Endorsement, per ISO form CA 9948 or equivalent and MCS 90 are required.

PROP-1 Property Coverage

Coverage	Limits, Other Provisions	Policy No. & Company	Policy Period
<input checked="" type="checkbox"/> Personal Property, Contents, Fixtures, Tenant Improvements and Betterments	<ul style="list-style-type: none"> • 100% of the Replacement Cost value of Personal Property, Contents, Fixtures, Tenant Improvements and Betterments • Covered Cause of Loss – Special Form including glass coverage and signs • Replacement Cost Endorsement 		
<input checked="" type="checkbox"/> Business Income including Loss of Rents	Amount equal to all Minimum Annual Rent and Other Sums payable under the Lease		

Any Policy issued under this section must contain, include or provide for the following:

1. City, its officers, officials and employees as additional insureds.
2. Waiver of Subrogation Applies to City as Landlord for any protected Landlord Property.
3. In the event of payment of any Loss involving Tenant Improvements and Betterments, permanent fixtures, etc, the insurance carrier shall pay the City (as Landlord) its designee first for said property loss

II. ADDITIONAL COVERAGE

UL-1 Umbrella Liability

Coverage	Minimum Limits of Liability (In Thousands)	Policy No. & Company	Policy Period
Umbrella Liability <input checked="" type="checkbox"/> Non-restricted area access	Each occurrence and aggregate \$1,000		
<input type="checkbox"/> Unescorted airside access	Each occurrence and aggregate \$9,000		

Any Policy issued under this section must contain, include or provide for the following:

1. City, its officers, officials and employees as additional insureds.
2. Coverage in excess of, and at least as broad as, the primary policies in sections WC-1, CGL-1, and BAL-1.
3. If operations include unescorted airside access at DIA, then a \$9 million Umbrella Limit is required.

4. If Liquor Liability is covered in the underlying General Liability coverage or is a separate policy, the Umbrella policy is also to provide coverage for Liquor Liability.

III. ADDITIONAL CONDITIONS

It is understood and agreed, for the benefit of the City, that the following additional conditions shall apply to all coverage specified herein:

1. All coverage provided herein shall be primary and any insurance maintained by the City shall be considered excess.
2. The City shall have the right to verify or confirm, at any time, all coverage, information or representations contained herein, and the insured and its undersigned agent shall promptly and fully cooperate in any such audit the City may elect to undertake.
3. Advice of renewal is required
4. All Insurance companies issuing policies hereunder must carry at least an A-VI rating from A.M. Best Company or obtain a written waiver of this requirement from the City's Risk Administrator.
5. Compliance with coverage requirement by equivalent herein must be approved in writing by the City's Risk Administrator prior to contract execution.
6. No changes, modifications or interlineations on this Certificate of Insurance shall be allowed without the review and approval of the Risk Administrator prior to contract execution.
7. The Insured named above shall promptly advise the City in the event any general aggregates or other aggregate limits are reduced below the required per occurrence limits. At the Insured's expense, the Insured will reinstate the aggregate limits to comply with the minimum requirements and shall furnish to the City a new Certificate showing such coverage is in force.

IV. NOTICE OF CANCELLATION

It is understood and agreed that should any Policy issued hereunder be cancelled or non-renewed before the expiration date thereof, or sustain a material change in coverage adverse to the City, the issuing company or its authorized Agent shall mail to the address shown above, by mail, return receipt requested, thirty (30) days prior written notice ten (10) days for non-payment of premium, referencing the contract/project number set forth herein.

**EXHIBIT D
CONFIRMATION LETTER
ESTABLISHING ACTUAL DATE OF POSSESSION
OR CHANGE IN DESIGN AND CONSTRUCTION DEADLINE
AND CONFIRMING THE TERM AND REFURBISHMENT DEADLINE**

Pursuant to the requirements of this Agreement, the City and Concessionaire agree that the Target Possession Date or the Design and Construction Deadline as set forth on the Summary Page may have changed and therefore some or all of the following dates may have changed. Accordingly, as of the date below the signature of the Manager, the following dates are hereby confirmed:

Date of Actual Possession of the Concession Space: _____

Design and Construction Deadline: _____

Term:

 Required Opening Date: _____

 Expiration Date: _____

Rent Commencement Date: _____

*Refurbishment Date:

*This field is not applicable unless the term exceeds five years

Concessionaire:

By:

Title: _____

Countersigned and Approved by the City:
Kim Day, Manager of Aviation

By: _____

Title: _____

Date: _____

EXHIBIT D1

LETTER CONFIRMING

ACTUAL DATES OF CERTAIN EVENTS

The City and Concessionaire hereby confirm the dates the following events occurred:

*Date Interim Rent Actually Commenced: _____
(Not applicable unless concession opens after Required Opening Date.)

Date Concession Actually Opened: _____

Date Rent Actually Commenced: _____

Concessionaire:

By: _____

Title: _____

Date: _____

Countersigned and Approved by the City:
Kim Day, Manager of Aviation

By: _____

Title: _____

Date: _____

EXHIBIT E
APPROVED MENU

[Concept & Menus]



White Wine Flights

A flight is a taste of three 2 oz. Wines that are related to one another by grape varietal, geographic region or style.

Flight #1: Old World Whites \$11.00

From a variety of climates and terrains, note the exquisite differences in these wines. Look for flavors of citrus, melon, some earth, and good acidity to keep things lively.

Type	Region	Glass	Btl
Barone, Pinot Grigio '10	Venezie, Italy	8	30
Terras Gauda "Abadla de San Camplo" Albariño '09	Rias Baixas, Spain	11	42
Dr. Pauly Bergweiler "Wehlener Sonnenhur" Riesling '06	Mosel, Germany	14	55

Flight #2: Rocky Mountain Whites \$12.00

Grapevines were first brought to Colorado in the 19th century by miners in southern Colorado. Colorado's grape growing regions contain some of the highest elevation vineyards in the world, with most viticulture in the state practiced between 4,000 and 7,000 feet above sea level, resulting in great acidity in these whites.

Type	Region	Glass	Btl
The Infinite Monkey Theorem Sav Blanc/Semillon '09	Grand Valley	9	34
Bodega del Desierto Chardonnay "Alto" '08	Valle del Rio	8	32
Sutcliffe Vineyards Chardonnay '09	Colorado	13	50

Flight #3: First Class Chardonnays \$13.00

Chardonnay grapes are grown throughout the world and are planted in many different soil types. Here you will taste a variety of great new world chards. This flight is ripe, direct, and luscious.

Type	Region	Glass	Btl
Talbott "Logan" '08	Santa Lucia Highlands, California	9	34
Chalone Estate '08	Chalone, California	12	45
Nickel & Nickel "Searby Vineyard" '08	Russian River Valley, California	18	70

Flight#4: Spectacular Sauvignon Blanc \$12.00

Sauvignon Blanc wines have noticeable acidity and a grassy, herbaceous aroma and flavor. They are crisp, flavorful wines that generally should be drunk young.

Type	Region	Glass	Btl
Les Rochettes Sancerre '09	Loire Valley, France	11	42
Whitehaven '09	Marlborough, New Zealand	11	42
Cakebread '09	Napa Valley, California	14	55

Flight#5: Everyone Loves Bubbles \$14.00

These Old World sparkling wines range from light and fruity to lean, rich, creamy, lush and complex. These wines can be associated with celebrating, or just enjoyed for any reason.

Type	Region	Glass	Btl
Killa Cava Brut N.V.	Spain	8	30
Nicolas Feuillatte, Brut N.V.	Champagne, France	14	60
Heidsieck Monopole "Blue Top" Brut N.V.	Champagne, France	17	78

Flight#13: Stop and Smell the Rosés \$11.00

Rosé is a different sort of wine, with all the refreshing qualities of a white wine mixed with some characteristics of a red. It can be made from many different grape varietals and in many different regions, the most popular and successful being Southern France, California, Spain, and Italy

Type	Region	Glass	Btl
Kestrel Vintners '09	Yakima Valley, Washington	8	32
Etude '10	Carneros, California	12	46
Alexander Valley Vineyards '10	Alexander Valley, California	9	34

[Concept & Menus]



Red Wine Flights

A flight is a taste of three 2 oz. Wines that are related to one another by grape varietal, geographic region or style.

Flight #6 Mendoza Madness \$12.00

Argentina is the largest wine producer in South America, the 5th largest in the world, and makes some of the best Malbec around. Look for flavors of plum and dark cherry with ample tannins in these rich and juicy wines.

Type	Region	Glass	Btl
Taymenté, Cabernet Sauvignon '09	Mendoza, Argentina	9	34
Tikal "Natural" Malbec '09	Mendoza, Argentina	12	45
Achaval Ferrer, Malbec '09	Mendoza, Argentina	13	50

Flight #7 European Vacation \$11.00

Let's take a trip across Europe and visit some of the great Old World wine regions. You'll find many distinct characteristics in these wines based directly on soil and climate, along with centuries of winemaking tradition. Don't forget your passport, and get ready for a great mix of Old World wines to enjoy!

Type	Region	Glass	Btl
Las Rocas de San Alejandro, Garnacha '08	Calatayud, Spain	8	30
Poliziano, Rosso di Montepulciano '08	Tuscany, Italy	10	38
Perrin Vacqueyras '08	Southern Rhone, France	13	50

Flight #8 Sexy Reds \$15.00

This seductive flight celebrates smooth texture, voluptuous mouth feel, and flavors that deliver a completely satisfying experience. There is also a little spice thrown in just to keep things interesting.

Type	Region	Glass	Btl
Penfolds "Bin 128" Shiraz '08	Coonawarra, Australia	12	45
Orin Swift "Prisoner" '09	Napa Valley, California	17	65
Paradigm, Cabernet Franc '07	Oakville, California	19	75

Flight #9 California Cabernet \$14.00

This flight brings you quality examples of what makes Cabernets stand out amongst their competitors. Here are some of our favorites. Look for flavors of currant, plum, black cherry, spice, and leather.

Type	Region	Glass	Btl
Louis M. Martini '08	Sonoma County	9	34
Rombauer '06	Napa Valley	15	60
Hall Winery '07	Napa Valley	17	65

Flight #10 Colorado Wine Tour \$13.00

The majestic valleys of Colorado's Rocky Mountains are blessed with warm days, cool nights and low humidity, perfect conditions for the cultivation of wine grapes with the complex character and chemistry required to produce award-winning wines. Of the over 100 wineries in the State, these 3 are among our favorites.

Type	Region	Glass	Btl
Bodega del Desierto "Pampa" Malbec '08	Alto Valle del Rio	15	60
Guy Drew Petite Verdot '07	Montezuma County	12	45
The Infinite Monkey Theorem Syrah '08	Grand Valley	14	55

Flight #11 Pinot Noir Perfection \$13.00

Pinot Noir's structure and elegance can be found in these wines below. Native to Burgundy, France, Pinot Noir has always been a sleek, sexy, and versatile varietal. These are examples of New World producers making great Pinot. Look for aromas of dark cherry, cranberry, raspberry and earth.

Type	Region	Glass	Btl
Russian Hill '07	Russian River Valley, California	9	36
Van Duzer '07	Willamette, Oregon	13	50
Stoller Estate "SV" Estate '07	Dundee Hills, Oregon	17	65

Flight #12 Sinful Zins \$15.00

Zinfandel can produce wines ranging from light, nouveau styles to hearty, robust reds with berrylike, spicy (sometimes peppery) flavors, plenty of tannins and alcohol, and enough depth, complexity, and longevity to be compared to cabernet sauvignons.

Type	Region	Glass	Btl
Bargetto "Old Vine" '08	Lodi, California	8	32
Cline "Big Break" '09	Contra Costa County, California	12	45
Turley "Old Vine" '09	California	15	60

CRÚ

FOOD & WINE BAR

TASTE & SHARE

Seared Salmon Salad | 12
couscous + baby lettuce + basil citrus dressing

Ahi Tartare | 13
avocado + cucumber + cilantro + citrus tapenade

Tomato-Mozzarella | 9
vine ripened tomatoes + buffalo mozzarella + basil + evo

Charcuterie | 14
prosciutto + salami + foie gras + antipasti + rustic bread

Seared Crab Cake | 14
jumbo blue crab + micro herbs + red pepper rémoulade

Cheese Fondue | 14
fontina + gruyere + gorgonzola + truffle oil + apples + pears
sweet peppers + rustic bread

Lamb Lollipops | 16
goat cheese + mint + balsamic reduction + crispy prosciutto + fig demi

Charcuterie, Cheese & Rustic Bread | 16
prosciutto + salami + foie gras + manchego + goat cheese

PANINI

BLT Panini | 9
prosciutto + arugula + tomato + goat cheese

Brie & Prosciutto Panini | 11
warm brie + italian prosciutto + fig jam

Grilled Cheese & Tomato Basil Soup | 11
taleggio cheese panini + white truffle oil + tomato basil soup

Roasted Chicken Panini | 12
lemon caper dressing + arugula + ciabatta roll

DESSERT

Limoncello Cheesecake | 8
almond biscotti crust + strawberry preserves

Chocolate Molten Lava Cake | 9
raspberry sauce + vanilla cream

Crème Brûlée | 8
vanilla bean custard + raspberries

ARTISAN CHEESE

Flights include Rustic Bread, Apples, Pears & Grapes

Classic | 15

Neal's Yard Dairy Colston Bassett Stilton, England
rich mineral tangy + buttery savory texture

Piave Vecchio, Italy
cow's milk + nutty + sweet

Manchego, Spain
zesty + exuberant sheep's milk + firm + dry

Great American | 15

St. Mary Gouda, Wisconsin
cow's milk + herbal tones + sweet + nutty + firm creamy

Petit Frère, Crave Brothers, Wisconsin
cow's milk + luscious velvety texture + fruity flavor

Laura Chenel's Chevre, Sonoma
soft goat's milk + fresh creamy chevre + light hint of grass

Sinful Experience | 16

Humboldt Fog, Cypress Grove, California
goat's milk + soft crack of ash through the center

Robiola, Italy
cow's milk + soft ripened + buttery + hints of mushroom

Delice de Jura, France
reblochon style + earthy tones + rich + creamy cow's milk

FLAT BREAD PIZZA

Pear & Gorgonzola | 14
comice pears + caramelized onion + basil + honey + parmesan

Five Cheese | 13
mozzarella + fontina + parmesan + goat + gorgonzola
white truffle oil

Margherita | 12
fresh mozzarella + tom basil + tomato sauce

Pepperoni | 14
goat + mozzarella + roasted peppers + spicy pepperoni

Cru Steak | 16
beef tender + arugula + red onion + balsamic reduction

EXHIBIT H

STREET PRICING COMPARABLE FACILITIES (Provided by Concessionaire)

EXHIBIT H

STREET PRICING COMPARABLE FACILITIES (Provided by Concessionaire)

Cru – A Wine Bar

1442 Larimer Square
Denver, Colorado

Cru - A Wine Bar

Park Meadows
8401 Park Meadows Center Dr.
Zone F [Level Ground]
Lone Tree, CO 80124-5128

EXHIBIT I

INDEPENDENT AUDITOR'S REPORT

We have audited the accompanying schedule of revenues (as defined in the lease agreement dated March 4, 20XX, between ABC Inc., as lessee, and Denver International Airport, as lessor) of ABC Inc. at its Denver International Airport store, for the year ended December 31, 20X2. This schedule is the responsibility of ABC Inc.'s management. Our responsibility is to express an opinion on this schedule based on our audit.

We conducted our audit in accordance with auditing standards generally accepted in the United States of America. Those standards require that we plan and perform the audit to obtain reasonable assurance about whether the schedule of gross sales is free of material misstatement. An audit includes examining, on a test basis, evidence supporting the amounts and disclosures in the schedule of gross sales. An audit also includes assessing the accounting principles used and significant estimates made by management, as well as evaluating the overall schedule presentation. We believe that our audit provides a reasonable basis for our opinion.

In our opinion, the schedule of revenues referred to above presents fairly, in all material respects, the gross revenue of ABC Inc. at its Denver International Airport store, for the year ended December 31, 20X2, as defined in the lease agreement referred to in the first paragraph.

This report is intended solely for the information and use of the boards of directors and managements of ABC Inc. and Denver International Airport and is not intended to be and should not be used by anyone other than these specified Parties.

[Signature]

[Date]

EXHIBIT J

INDEPENDENT ACCOUNTANT'S REPORT ON APPLYING AGREED-UPON PROCEDURES

To the Management of ABC Inc. and Denver International Airport:

We have performed the procedures enumerated below, which were agreed to by the Management of ABC Inc. and Denver International Airport, solely to assist you in evaluating the accompanying Statement of Revenues for the year ended December 31, 20X1. ABC Inc.'s management is responsible for the statement of revenues. This agreed-upon procedures engagement was conducted in accordance with attestation standards established by the American Institute of Certified Public Accountants. The sufficiency of these procedures is solely the responsibility of those parties specified in this report. Consequently, we make no representation regarding the sufficiency of the procedures described below either for the purpose for which this report has been requested or for any other purpose.

The procedures and associated findings are as follows:

Agree the revenue for each of the months in the year ended December 31, 20X1 as listed on the statement of revenues to the ABC Inc. general ledger.

For the months of April and September 20X1, agree the total revenues to the underlying cash register receipts.

For a sample of 10 days within the months selected above, agree the underlying cash receipts to bank deposit slips and bank statements.

For the two months selected above, agree the sales tax amounts from the schedule of revenue into the sales tax returns as filed.

We were not engaged to and did not conduct an examination, the objective of which would be the expression of an opinion on the accompanying Statement of Revenues of ABC Inc. Accordingly, we do not express such an opinion. Had we performed additional procedures, other matters might have come to our attention that would have been reported to you.

This report is intended solely for the information and use of the managements of ABC Inc. and Denver International Airport and is not intended to be and should not be used by anyone other than these specified parties.

[Signature]

[Date]

EXHIBIT L
CONCESSION REVENUE MONTHLY REPORT

EXHIBIT L

DENVER
INTERNATIONAL
AIRPORT

FOOD AND BEVERAGE CONCESSION REVENUE MONTHLY REPORT

For the month of: _____ (Mo. Year) Due on the 10TH DAY of the following month.

FROM: _____ Store name/location identifier:
(Company Name)

(Address)

Telephone # _____ Fax # _____

email _____

CUMULATIVE
REPORTABLE REVENUE
FROM PRIOR MONTH:

	FOOD	MERCHANDISE	ALCOHOL	
1. GROSS REVENUE	\$ _____	\$ _____	\$ _____	_____
2. REPORTABLE REV. THIS MO (Subtract Allowable Deduct	\$ _____	\$ _____	\$ _____	_____
3. PERCENTAGE COMPENSATION FEE				
Current Non-Alcohol Rate _____				
New Rate -when cumulative amt. reached _____				
Alcohol Rate _____				
TOTAL % COMPENSATION AMOUNT	\$ _____	\$ _____	\$ _____	_____
4. MINIMUM MONTHLY GUARANTEE	\$ _____			
5. PERCENTAGE AMOUNT DUE - line 3 less line 4	\$ _____			
6. 1% - JOINT MARKETING FUND (if applicable)	\$ _____			
7. TOTAL AMOUNT DUE WITH REPORT - line 5 + line 6	\$ _____			_____

CUMULATIVE
REPORTABLE REVENUE
GOING FORWARD:

REMIT AMOUNT ON LINE 7 WITH THIS REPORT IF LINE 7 IS GREATER THAN ZERO

NOTE: LINE 4 (MMG) IS DUE IN ADVANCE AND WITHOUT NOTICE ON THE 1ST DAY OF EVERY MONTH.

LATE PAYMENTS ARE ASSESSED INTEREST AND PENALTY CHARGES PER CONTRACT. LATE REPORTS ASSESSED \$100/DAY/REPORT.

MAKE CHECK PAYABLE TO: AIRPORT REVENUE FUND

Mail check to:

P.O. Box 492065

Denver, CO 80249-2065

OATH OF CONCESSIONAIRE:

The undersigned, being first duly sworn, deposes and says, that the gross revenues shown by this statement are true and just, and the percentage shown is due the City and County of Denver in accordance with the Concession Agreement.

(Please attach subtenants' concession revenue reports if there are any)

Signature

Authorized Officer

Date

EXHIBIT N

DIA ENVIRONMENTAL REQUIREMENTS

Section 1. General Requirements. As used below the term "Tenant" shall mean and include the "Party of the Second Part. Tenant, in conducting any activity on DIA property, shall comply with all applicable airport, local, state, and federal rules, regulations, statutes, laws, and orders (Environmental Requirements). In addition, these Environmental Requirements include applicable Environmental Guidelines developed for DIA's Environmental Management System (EMS), as summarized in DIA Rules and Regulations Part 180. DIA's Environmental Guidelines, Environmental Policy, and all Rules and Regulations are available at www.flydenver.com. These Environmental Requirements address, but are not limited to, requirements regarding the storage, use, and disposal of Hazardous Materials, solid and hazardous waste, or petroleum products; the National Environmental Policy Act (NEPA); and other federal, state, and local water, wastewater, and air quality regulations.

A. EMS: DIA's EMS has been certified to the ISO 14001 standard. DIA's EMS includes the above-noted airport-wide Environmental Policy and is designed around the significant aspects identified in DIA Rule and Regulation 180. It is a requirement of the standard that all entities providing products, goods, and/or services on behalf of DIA ensure that their personnel are aware of DIA's Environmental Policy, DIA's significant environmental aspects, and the specific environmental aspects and associated impacts for the products, goods, and/or services that will be provided by the Tenant,

B. Permits: Tenant shall acquire all necessary federal, state, local and airport permits/approvals and comply with all permit/approval requirements. Tenant shall prepare and update all plans and provide all information required by the City for regulatory compliance purposes and provide copies of all permit applications and permits to DIA.

C. Hazardous Materials Limited: Any hazardous materials not normally used in Tenant's operations are barred from DIA premises. Tenant shall identify all hazardous materials to be used at DIA along with a description of how these materials and any associated hazardous or other waste materials generated by Tenant will be managed while on airport property. This information is required prior to the Tenant conducting activities on DIA property.

D. MSDSs: Prior to operation, Tenant shall maintain copies of Material Safety Data Sheets (MSDSs) for all chemicals to be used in their activities, including those used for cleaning and maintenance. This obligation is continuing for the term of this Agreement, and Tenant shall make this documentation available for inspection by DIA upon request.

E. Pollution Prevention: Tenant is encouraged to utilize the concepts of pollution prevention, energy efficiency and waste minimization with regard to its activities at DIA.

Section 2. Review of Environmental Documents. Tenant, at the request of the City, shall make available for inspection and copying, upon reasonable notice and at reasonable times, any or all of the documents and materials that the Tenant has prepared pursuant to any Environmental Requirement hereunder or submitted to any governmental or regulatory agency. If there is a requirement to file any notice or report of a release or threatened release of a

substance on, under or about the work conducted on DIA property, Tenant shall provide a copy of such report or notice to the City.

Section 3. Access for Environmental Inspection. The City shall have an unimpeded right of access to the occupancy or work areas without prior notice to Tenant to inspect the same in order to confirm that Tenant is conducting its activities in accordance with this Agreement. At the City's request, Tenant shall conduct any testing and analysis at its cost as is necessary to ascertain whether the Tenant is in compliance with this Agreement.

Section 4. Correction of Environmental Non-Compliance. If the Tenant fails to comply with any applicable Environmental Requirement, the City, in addition to its rights and remedies described elsewhere in this Agreement, at its election, may enter the facility and/or work area and take such measures as may be necessary to ensure compliance with the Environmental Requirements, all at the Tenant's expense.

Section 5. Duty to Notify City. In the event of a release or threatened release of a substance relating to or arising out of the Tenant's use or activities on DIA, or in the event any claim, demand, cause of action, or notice is made against the Tenant with regard to the Tenant's failure or alleged failure to comply with any requirement hereunder, the Tenant, immediately shall notify the City verbally by contacting the Airport Communications Center (303-342-4200) and the appropriate regulatory agency. Tenant shall immediately control and remediate the contaminated media and, as provided below, follow-up Tenant's verbal notice with a written report within three days of such incident. In addition, the Tenant shall provide the City, at Tenant's expense, with copies of any written claims, demands, notices or actions so made.

Section 6. Environmental Remediation. Tenant shall undertake all actions necessary to remedy or remove any released or spilled materials and any other contamination discovered on or under DIA property introduced by or affected by Tenant and shall restore the Access Premises to either its condition immediately prior to the initiation of this Agreement or to a condition in compliance with all applicable local, state, federal, or airport laws, rules, regulations, or orders, at the City's sole discretion. This work shall be performed at Tenant's expense and the City shall have the right to review the project plan and review and inspect all such work at any time using consultants and representatives of the City's choice. Tenant shall further conduct surface and subsurface monitoring pertaining to Tenant's activities hereunder to ensure compliance with applicable laws, rules, regulations, and permits or as determined by the Manager of Aviation.

Section 7. Environmental Requirements for Construction. Tenant agrees to ensure that its premises are designed, constructed, operated, and maintained in a manner that minimizes environmental impacts through application of appropriate preventive measures and complies with all federal, state, and local environmental requirements. Tenant shall comply with the DIA Tenant Development Guidelines, as amended, for any alterations to existing facilities or the construction of any new facilities. In addition, the Tenant shall comply with **Exhibit X** of this agreement.

EXHIBIT X

PROVISIONS FOR DESIGN AND CONSTRUCTION OF IMPROVEMENTS

GENERAL PROVISIONS

SECTION 1: GENERAL. Except as the context otherwise requires and unless otherwise expressly provided herein, the capitalized terms in this *Exhibit X* to the Agreement shall have the same meaning as any similarly capitalized terms defined in the Agreement or any exhibit thereto. Reference to Denver International Airport (DIA), Department of Aviation or Manager of Aviation shall mean that entity specifically, or that division or individual authorized to represent that entity. As used below the term "Tenant" shall mean and include the "Party of the Second Part.

SECTION 2: IMPROVEMENTS. "Improvements," which may also be known as "Concession Improvements" or "Tenant Improvements," shall mean any new construction, equipment, finishes, fixtures, systems, furnishings and furniture installed by Tenant, as well as modifications or alterations to existing construction, equipment, finishes, fixtures, systems, furnishings and furniture which conform to drawings and specifications approved in writing by the Manager of Aviation. Such drawings and specifications must provide for the necessary and proper operation of the business contemplated under this Agreement.

SECTION 3: COMPLIANCE WITH LAWS AND REGULATIONS. Tenant agrees to comply with and require its contractors to comply with all applicable federal, state and local laws and all general rules and regulations applicable to construction at DIA, including but not limited to payment of prevailing wages and sales and use taxes, compliance with the Americans with Disabilities Act, 42 USC 12,000 et seq. and its regulations.

In addition to the above, the Tenant and its contractors shall comply with all DIA specific rules and regulations regarding site access, use of site, safety, security, design and construction and shall obtain and pay for all related permits. Failure to comply will be grounds for denial of access and/or suspension of construction activities. Regulations in force specific to DIA include but are not limited to the following:

The Denver Municipal Airport System Rules and Regulations

DIA Design Standards

DIA Tenant Development Guidelines

SECTION 4: PAYMENT OF PREVAILING WAGE RATES. Tenant shall require its contractor and all of its subcontractors to pay every worker, laborer or mechanic employed by them in the performance of the construction of the Improvements prevailing wages, including fringe benefits or their cash equivalent, for the same class and kind of work in the City and County of Denver, as determined by the Career Service Board under the provisions of Section 20-76 of the Denver Revised Municipal Code. The wages shall be those prevailing at the time of the contractor's final bid, and the Tenant shall require the contractor to submit with its bid the wage schedule applicable. The contractor shall post in a prominent and easily accessible place at the site of the Improvements the scale of wages to be paid by the contractor and all subcontractors at any tier working under the contractor. The contractor shall furnish to the Mayor's Office of Contract

Compliance and to the Auditor, or the Manager's authorized representative, each week during which work is in progress, a true and correct copy of the payroll records of all workers employed to perform the work. All payroll records shall include information showing the number of hours worked by each worker, the hourly pay of such worker, any deductions made from pay, and the net amount of pay received by such worker for the period covered by the payroll. The payroll record shall be accompanied by a sworn statement of the contractor that the copy is a true and correct copy of the payroll records of all workers performing the work, either for the contractors or subcontractors, that payments were made to the workers as set forth in the payroll records, that no deductions were made other than those set forth in such records, and that all workers were paid the prevailing wages as of the contractor's final bid for the work. Compliance with above requirements shall be deemed a work "specification" as such word is used in Section 5-18(d), Denver Revised Municipal Code. Violation of the prevailing wage requirement and its documentation, hereinabove set forth, shall result in an order from the Manager of Aviation for the work to cease until there is satisfactory evidence that the violation has been remedied and will not reoccur. The issuance of a stop-work order shall not relieve contractor's surety of any liability on contractor's bond or bonds, but such a stop-work order shall be deemed a default by the contractor insofar as said surety's obligation is concerned.

SECTION 5: SBE AND MBE/WBE PARTICIPATION. This Agreement is subject to the requirements of Articles III and VII of the Denver Revised Municipal Code.

Tenant agrees that it shall provide for participation of Small Business Enterprises (SBEs) in the design and construction of Improvements, in compliance with Article VII, Division 1 of Chapter 28, Denver Revised Municipal Code (D.R.M.C.), or any successor ordinance effective at the time of any design and construction that Tenant may carry out during the life of this Agreement. The goal for percentage of design and construction work to be performed by SBE firms is set forth on the Construction Summary Page, and Tenant shall make a good faith effort to meet such goals as have been set in accordance with the ordinance. Further, the City and County of Denver encourages Tenants to utilize SBEs and to divide the design and construction work into economically feasible units or segments to allow the most opportunity for subcontracting.

Tenant agrees that it shall provide for participation of Minority Business Enterprises ("MBE") and Women Business Enterprises ("WBE") in the design and construction of Improvements, in compliance with the requirements of Article III, Divisions 1 and 3 of Chapter 28, of the Denver Revised Municipal Code ("MBE/WBE Ordinance"), or applicable successor ordinance, during the life of this Agreement. Tenant agrees to comply with rules and regulations issued by the Director of the Division of Small Business Opportunity ("DSBO"), a division of the Mayor's Office of Economic Development. The goal for percentage of design and construction work to be performed by MBE/WBE firms is set forth on the Construction Summary Page, and Tenant shall meet, or make a good faith effort to meet, such goals as have been set in accordance with the ordinance. Further, the City and County of Denver encourages Tenants to utilize MBE/WBE firms and to divide the design and construction work into economically feasible units or segments to allow the most opportunity for subcontracting.

SECTION 6: INSURANCE REQUIREMENTS. Refer to Appendix B of Manual 1 of the DIA Tenant Development Guidelines for insurance requirements for Tenant, Tenant's Design Consultants and Tenant's Contractors for required insurance coverage for design and construction of Improvements and completed Improvements, including requirements for submittal of certificates and renewals of insurance.

SECTION 7: EVIDENCE OF INSURANCE. Certified copies of required insurance policies, or certificates, in the standard form required, evidencing the existence thereof, or binders, shall be delivered to the DIA Division of Planning and Development at least 15 days prior to the commencement of any design work to be performed by Tenant's consultants and any construction work for Improvements. If a binder is delivered, it shall be replaced within 30 days by a certified copy of the policy or the required certificate. Policies shall be in a form and of a company acceptable to and approved by the City, and certificates shall be on standard City and County of Denver Certificate of Insurance forms.

Each such policy or certificate shall contain a valid provision or endorsement that the policy may not be canceled, terminated, changed or modified without 45 days prior written notice (10 days for nonpayment of premium) given by certified mail, return receipt requested, to the Manager of Aviation, 8500 Peña Boulevard, Denver, Colorado 80249-6340.

Each such policy or certificate shall further provide that any coverage afforded the City and County of Denver as an additional insured under the policy shall apply as primary insurance and any other insurance issued to the City and County of Denver shall apply as excess and noncontributing insurance.

Any renewal certificate shall be delivered to the Manager of Aviation at least 10 days prior to the expiration of each expiring policy. If at any time any of the insurance policies shall be or become unsatisfactory to the Manager of Aviation as to form or substance, or if any of the carriers issuing such policies shall be or become unsatisfactory to the Manager of Aviation, Tenant shall promptly obtain a new and satisfactory replacement policy.

SECTION 8: LIMITATION ON LIABILITY. Tenant agrees that no liability shall attach to the City for any damages or losses incurred or claimed by Tenant or any other person or party on account of the construction or installation of the Improvements or other Improvements to the Tenant's site made by the Tenant. Tenant agrees that no liability shall attach to the City for any interference or delay caused by construction in adjacent areas, travelers, other businesses or airport operations, including without limitation damages or losses in the nature of delay damages, lost labor productivity, and impact damages. Tenant agrees to indemnify, defend and hold harmless the City from any loss, cost, damage or expense incurred, claimed, asserted or arising in connection with Tenant's or its contractors' or agents', construction or installation of the Improvements or other Improvements to the site made by the Tenant.

DESIGN PROVISIONS

SECTION 9: DESIGN PROCEDURES. Refer to Manual 1 of the DIA Tenant Development Guidelines for procedures and requirements regarding design, including but not limited to design process and schedule, submittal requirements, review and approval process, design modifications and project coordination.

Approval of the Manager of Aviation extends to and includes consideration of architectural, structural, mechanical, electrical, specialty systems, site, signage, landscaping and aesthetic matters, and DIA reserves the right to reject any design submitted and to require Tenant to resubmit designs and layout proposals until they meet with the approval of the Manager of Aviation. No substantial changes or alterations shall be made in said drawings or specifications

after approval by the Manager of Aviation, and no alterations or improvements shall be made to or upon the Tenant's site without prior approval.

Tenant CADD Submittal Requirements: All issue for construction and project record drawings shall be provided by the Tenant to DIA in AutoCAD Rel. 2007 .dwg file format in accordance with DIA CADD standards set forth in Design Standards Manual 1. All design drawings submitted by the Tenant to the DIA shall be provided in the latest release of AutoCAD format in accordance with the DIA's Design Standards Manual.

Concession CADD Submittal Requirements: AutoCAD 2007 .dwg format CADD files that match the Tenant's hardcopy drawings must be submitted via: CD-ROM or DVD-ROM in MS-Windows format. All drawings must represent precision input and follow industry standard CADD practices. The drawings must reflect true design dimensioning and must NOT be graphic representations of the design. All site, civil and utility drawings MUST be produced using units in feet and the DIA Grid Coordinate System. The DIA Project Manager must approve submittal and may require adherence to the requirements set forth in DIA design standards.

In addition to the above, Tenant is responsible for coordination with the Denver Building Inspection Division, Zoning, Fire Department, Wastewater Management, Consumer Protection, Health and Hospitals, etc. as may be required to comply with submittal, review and approval requirements in order to obtain all required permits. Prior to the issuance of a Notice to Proceed with Improvements from the Manager of Aviation, the Tenant shall obtain and pay for all approvals, licenses and permits required for the Improvements. Whenever a conflict arises between state or local law, ordinances or regulations and federal law or regulations, the most stringent law or regulations applicable to this Agreement shall control.

SECTION 10: DESIGN STANDARDS. First-class standards of design and construction are required, and all Improvements shall conform to applicable statutes, ordinances, building codes, and regulations as well as the DIA Design Standards and DIA Tenant Development Guidelines, as they may be amended from time to time and any other applicable design, construction and maintenance standards.

Approval of the Manager of Aviation shall extend to and include consideration of architectural and aesthetic matters and the City reserves the right to reject any designs submitted and to require the Tenant to resubmit designs and layout proposals until they meet with the City's approval. If any portion of the plans and specifications is disapproved by the City, the Tenant shall promptly submit necessary modifications and revisions thereof. The approval given by the Manager of Aviation shall not constitute a representation or warranty as to such conformity; therefore, responsibility remains with the Tenant at all times.

CONSTRUCTION PROVISIONS

SECTION 11: CONSTRUCTION PROCEDURES. Refer to Manual 1 of the DIA Tenant Development Guidelines for procedures and requirements regarding construction, including but not limited to construction schedule, submittal requirements, review and approval process, construction inspections, construction modifications and project coordination.

Compliance with standards: All construction work shall comply with the requirements of and standards established by the City and all other appropriate governmental agencies and entities. The City shall at all times have the right to monitor and inspect any construction to assure that

the Improvements are constructed and installed in full compliance with the plans and specifications.

Standard of Performance: All work done by the Tenant or its contractors shall be done in a first-class workmanlike manner using only good grades of materials and shall comply with all insurance requirements and all applicable laws and ordinances and rules and regulations of governmental departments or agencies. Whenever a conflict arises between State or local law, ordinances or regulations and Federal law or regulations, Federal law or regulations applicable to this Agreement shall control.

City Inspection: All construction work, materials and installations involved in or incidental to the construction of the improvements undertaken by the Tenant throughout the term hereof shall be subject at all times to inspection and approval by the City. DIA shall at all times have the right of access to the construction site and to monitor and inspect the construction of all Improvements to insure that all Improvements are constructed and installed in compliance with approved drawings and specifications.

DIA shall have the right to halt construction of the Improvements or deny access to the site at any time if construction is at material variance from the approved drawings and specifications until such variance is corrected, or if such construction poses an immediate safety hazard at the Airport, until such safety hazard is eliminated. The City shall cooperate and use its best efforts to alleviate and resolve any such variance or impediment to the safe operation of the Airport so as to permit continued construction as expeditiously as possible.

In order to assist DIA in monitoring and inspecting construction, the Tenant shall submit, or cause to be submitted for information and record, copies of all field test reports, certificates of insurance, waivers of liens, material certificates, shop drawings and submittals for review for compliance with DIA design and construction standards, contractor application for payment requests, construction progress reports, notification of substantial completion of Improvements and final acceptance, two copies of maintenance and operation manuals in connection with building systems and all updates thereof, as-built documents, and any other documents related to the construction of the Improvements which may be reasonably requested by DIA.

No change order or other contract modification that materially changes the scope of the Improvements shall be executed without prior approval of the Manager of Aviation, whose approval shall not be unreasonably withheld. The City will approve, conditionally approve or disapprove submissions of change orders that materially change the scope of the work within a reasonable period of time following receipt thereof. Any conditional approval or disapproval shall be accompanied by an explanation as to the reason for the condition.

The Building Inspection Division of the City and County of Denver shall also receive copies of all change orders. Any conditional approval or disapproval shall be accompanied by an explanation of the reasons.

Tenant is responsible for all temporary utilities required during construction. Tenant, at its sole cost and expense, shall obtain and make utility connections, hook-ups or taps as necessary or as stipulated in this Agreement, securing all necessary applications or permits and paying all associated fees. Tenant, at its sole cost and expense, shall provide meters, calibrated by the utility company, and maintain equipment as required to provide accurate measurement of usage

and consumption. DIA makes no warranty as to the location of structures, wiring, fixtures or systems, and Tenant accepts them on an "as is" basis without further recourse against DIA as to their location, number or suitability for the particular purposes of the Tenant.

Tenant is responsible for maintaining a clean, orderly and safe construction site, free of accumulated construction debris and waste materials and shall be responsible for legal removal of same. Construction shall be accomplished without interfering with travelers, airport operations or other businesses, providing barricades and/or construction enclosures as required.

SECTION 12: CONSTRUCTION BONDS AND PERMITS. Prior to Notice to Proceed with construction Improvements, Tenant and its contractor shall deliver to the Manager of Aviation performance and payment bonds and copies of all required permits, licenses and all other documents as required by Manual 1 of the DIA Tenant Development Guidelines.

SECTION 13: MODIFICATIONS AND ALTERATIONS. Modifications and alterations to existing Tenant improvements are subject to the same requirements and provisions as new tenant improvements as itemized in this *Exhibit X* and this Agreement.

Advance Notice of Modification: The Tenant shall give or cause to be given to the City advance notice before performing any material modification to the improvements.

Expense of Alterations. Any work necessary to make any alterations, improvements, or additions to the facility throughout the term of this Agreement shall be done at the Tenant's cost and expense, in accordance with and subject to all of the required approvals, submittals, and procedures, and all other requirements of whatsoever nature, as set forth herein.

SECTION 14: AS-BUILT DOCUMENTS. Not later than 60 days after completion of all work for the Improvements, Tenant shall provide DIA two complete sets of as-built documents prepared in accordance with DIA requirements. If Tenant fails to provide as-built documents after written notice from DIA, DIA may elect to have the documents completed and charge the Tenant for the costs associated therewith. Tenant agrees that, upon the request of DIA, Tenant will inspect the Improvements jointly with DIA to verify as-built documents.

APPENDIX NO. 1

STANDARD FEDERAL ASSURANCES

NOTE: As used below the term "contractor" shall mean and include the "Party of the Second Part," and the term "sponsor" shall mean the "City."

During the term of this contract, the contractor, for itself, its assignees and successors in interest (hereinafter referred to as the "contractor") agrees as follows:

1. **Compliance with Regulations.** The contractor shall comply with the Regulations relative to nondiscrimination in federally assisted programs of the Department of Transportation (hereinafter "DOT") Title 49, Code of Federal Regulations, Part 21, as they may be amended from time to time (hereinafter referred to as the Regulations), which are herein incorporated by reference and made a part of this contract.

2. **Nondiscrimination.** The contractor, with regard to the work performed by it during the contract, shall not discriminate on the grounds of race, color or national origin in the selection and retention of subcontractors, including procurements of materials and leases of equipment. The contractor shall not participate either directly or indirectly in the discrimination prohibited by Section 21.5 of the Regulations, including employment practices when the contract covers a program set forth in Appendix B of the Regulations.

3. **Solicitations for Subcontractors, Including Procurements of Materials and Equipment.** In all solicitations either by competitive bidding or negotiation made by the contractor for work to be performed under a subcontract, including procurements of materials or leases of equipment, each potential subcontractor or supplier shall be notified by the contractor of the contractor's obligations under this contract and the Regulations relative to nondiscrimination on the grounds of race, color, or national origin.

4. **Information and Reports.** The contractor shall provide all information and reports required by the Regulations or directives issued pursuant thereto and shall permit access to its books, records, accounts other sources of information, and its facilities as may be determined by the sponsor or the Federal Aviation Administration (FAA) to be pertinent to ascertain compliance with such Regulations, orders, and instructions. Where any information required of a contractor is in the exclusive possession of another who fails or refuses to furnish this information, the contractor shall so certify to the sponsor of the FAA, as appropriate, and shall set forth what efforts it has made to obtain the information.

5. **Sanctions for Noncompliance.** In the event of the contractor's noncompliance with the nondiscrimination provisions of this contract, the sponsor shall impose such contract sanctions as it or the FAA may determine to be appropriate, including, but not limited to:

a. Withholding of payments to the contractor under the contract until the contractor complies, and/or

b. Cancellation, termination or suspension of the contract, in whole or in part.

6. **Incorporation of Provisions.** The contractor shall include the provisions of paragraphs 1 through 5 in every subcontract, including procurements of materials and leases of equipment, unless exempt by the Regulations or directives issued pursuant thereto. The

contractor shall take such action with respect to any subcontract or procurement as the sponsor or the FAA may direct as a means of enforcing such provisions including sanctions for noncompliance. Provided, however, that in the event a contractor becomes involved in, or is threatened with, litigation with a subcontractor or supplier as a result of such direction, the contractor may request the sponsor to enter into such litigation to protect the interests of the sponsor and, in addition, the contractor may request the United States to enter into such litigation to protect the interests of the United States.

APPENDIX NO. 2

STANDARD FEDERAL ASSURANCES

NOTE: As used below, the term "DOT" means the United States Department of Transportation.

1. The Party of the Second Part for itself, representatives, successors in interest, and assigns, as a part of the consideration hereof, does hereby covenant and agree as a covenant running with the land that in the event facilities are constructed, maintained, or otherwise operated on the said property described in this agreement for a purpose for which a DOT program or activity is extended or for another purpose involving the provision of similar services or benefits, the Party of the Second Part shall maintain and operate such facilities and services in compliance with all other requirements imposed pursuant to 49 CFR Part 21, Nondiscrimination in Federally Assisted Programs of the Department of Transportation, and as said Regulations may be amended.

2. The Party of the Second Part for itself, representatives, successors in interest, and assigns, as a part of the consideration hereof, does hereby covenant and agree as a covenant running with the land: (1) that no person on the grounds of race, color, sex, creed or national origin shall be excluded from participation in, denied the benefits of, or be otherwise subjected to discrimination in the use of said facilities, (2) that in the construction of any improvements on, over, or under such land and the furnishing of services thereon, no person on the grounds of race, color, sex, creed or national origin shall be excluded from participation in, denied the benefits of, or otherwise be subjected to discrimination, (3) that the Party of the Second Part shall use the premises in compliance with all other requirements imposed by or pursuant to 49 CFR Part 21, Nondiscrimination in Federally Assisted Programs of the Department of Transportation, and as said Regulations may be amended.

APPENDIX NO. 3

NONDISCRIMINATION IN AIRPORT EMPLOYMENT OPPORTUNITIES

The Party of the Second Part assures that it will comply with pertinent statutes, Executive Orders and such rules as are promulgated to assure that no person shall, on the grounds of race, creed, color, national origin, sex, age, or handicap be excluded from participating in any activity conducted with or benefiting from Federal assistance. This Provision obligates the Party of the Second Part or its transferee for the period during which Federal assistance is extended to the airport program, except where Federal assistance is to provide or is in the form of personal property or real property or an interest therein or structures or improvements thereon. In these cases, this Provision obligates the Party of the Second Part or any transferee for the longer of the following periods: (a) the period during which the property is used by the sponsor or any transferee for a purpose for which Federal assistance is extended, or for another purpose involving the provision of similar services or benefits; or (b) the period during which the airport sponsor or any transferee retains ownership or possession of the property. In the case of contractors, this Provision binds the contractors from the bid solicitation period through the completion of the contract.

It is unlawful for airport operators and their lessees, tenants, concessionaires and contractors to discriminate against any person because of race, color, national origin, sex, creed or handicap in public services and employment opportunities.

APPENDIX NO. 10

DISADVANTAGED BUSINESS ENTERPRISES - REQUIRED STATEMENTS

Policy. It is the policy of the Department of Transportation that disadvantaged business enterprises as defined in 49 CFR Part 23 shall have the maximum opportunity to participate in the performance of contracts financed in whole or in part with federal funds under this agreement. Consequently, the ACDBE requirements of 49 CFR Part 23 apply to this agreement.

ACDBE Obligation. The recipient or its contractor agrees to ensure that disadvantaged business enterprises as defined in 49 CFR Part 23 have the maximum opportunity to participate in the performance of contracts financed in whole or in part with federal funds provided under this agreement. In this regard, all recipients or contractors shall take all necessary and reasonable steps in accordance with 49 CFR Part 23 to ensure that disadvantaged business enterprises have the maximum opportunity to compete for and perform contracts. Recipients and their contractors shall not discriminate on the basis of race, color, sex, creed or national origin in the award and performance of DOT-assisted contracts.

49 CFR 23.5 defines a DOT-assisted contract as "any contract or modification of a contract between a recipient and a contractor which is paid for in whole or in part with DOT financial assistance or any contract or modification of a contract between a recipient and a lessee." "Contractor" means ... "and includes lessees." The City is the "recipient."