

CITY AND COUNTY OF DENVER
STATE OF COLORADO



DENVER
THE MILE HIGH CITY

**DEPARTMENT OF TRANSPORTATION &
INFRASTRUCTURE**

Contract Documents

Contract Number: 202263315

Connecting Auraria

June 6, 2022



NOTICE TO APPARENT LOW BIDDER

Hamon Infrastructure, Inc.
5670 Franklin St.
Denver, CO 80216

The EXECUTIVE DIRECTOR OF THE DEPARTMENT OF TRANSPORTATION AND INFRASTRUCTURE has considered the Bids submitted on **July 14, 2022**, for work to be done and materials to be furnished in and for:

CONTRACT - 202263315 -CONNECTING AURARIA

as set forth in detail in the Contract Documents for the City and County of Denver, Colorado. It appears that your Bid is fair, equitable, and to the best interest of the City and County; therefore, said Bid is hereby accepted at the bid price contained herein, subject to the approval and execution of the Contract Documents by the City in accordance with the Charter of the City and County of Denver, and to your furnishing the items specified below. The award is based on the total bid items: **One Hundred Seventy-Five (175) base bid items (201-00001 through LS2)** the total estimated cost thereof being: **Six Million Three Hundred Forty-Five Thousand Nine Hundred and Ninety-Seven Dollars and Two Cents (\$6,345,997.02)**.

In accordance with the requirements set forth in the Contract Documents, you are required to furnish the following documents:

- a. Insurance Certificates: Commercial General Liability, Business Automobile Liability, Workman's Compensation and Employer Liability, Builder's Risk or Installation Floater and Professional Liability (Errors & Omissions); and
- b. Payment and Performance Bond along with One original Power of Attorney relative to Performance and/or Payment Bond.

All construction contracts made and entered into by the City and County of Denver are subject to Affirmative Action and Equal Opportunity Rules and Regulations, as adopted by the Manager of the Department of Transportation and Infrastructure, and each contract requiring payment by the City of one-half million dollars (\$500,000.00) or more shall first be approved by the City Council acting by ordinance or resolution and in accordance with Section 3.2.6 of the Charter of the City and County of Denver.

The Bid Security submitted with your Bid will be returned upon execution of the Contract and furnishing of the Performance Bond. In the event you should fail to furnish the Performance Bond or execute the contract within the time limit specified, said Bid Security will be retained by the City and County of Denver as liquidated damages, and not as a penalty for the delay and extra work caused thereby.

City and County of Denver Department of Transportation & Infrastructure
Office of the Executive Director
201 W. Colfax Avenue, Dept. 608 | Denver, CO 80202
www.denvergov.org/doti
Phone: 720-865-8630



NOTICE TO APPARENT LOW BIDDER

CONTRACT NO. 202263315

Page 2

Dated at Denver, Colorado this 18th day of August 2022.

CITY AND COUNTY OF DENVER

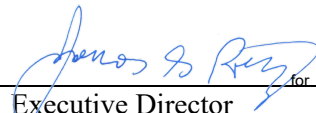
By:  for
Executive Director
Department of Transportation and Infrastructure

cc: Treasury, DSBO, PM, Prevailing Wage, PRO, File

City and County of Denver Department of Transportation & Infrastructure
Office of the Executive Director
201 W. Colfax Avenue, Dept. 608 | Denver, CO 80202
www.denvergov.org/doti
Phone: 720-865-8630

CITY AND COUNTY OF DENVER
STATE OF COLORADO



DENVER
THE MILE HIGH CITY

**DEPARTMENT OF TRANSPORTATION &
INFRASTRUCTURE**

Bid Form Package

Contract Number: 202263315

Connecting Auraria

June 6, 2022

**CITY AND COUNTY OF DENVER
DEPARTMENT OF TRANSPORTATION AND INFRASTRUCTURE**

TABLE OF CONTENTS FOR BID FORM AND SUBMITTAL PACKAGE

BIDDER'S CHECKLIST BF-2
BID FORM AND SUBMITTAL PACKAGE ACKNOWLEDGMENT..... BF-4
BID FORM..... BF-6
1A - LIST OF PROPOSED SUBCONTRACTORS, SUBCONSULTANTS, AND/OR SUPPLIERS BF-9
COMMITMENT TO MWBE PARTICIPATION BF-13
LETTER OF INTENT (LOI) BF-14
BID BOND..... BF-15
DIVERSITY AND INCLUSIVENESS IN CITY SOLICITATIONS INSTRUCTIONS BF-16



This Checklist is provided solely for the assistance of the bidders, and need not be returned by Bidders with your BID FORM PACKAGE.

BIDDER'S CHECKLIST

These forms comprise the Bid Form and Submittal Package. Please note that a copy of the executed bid bond is to be submitted via QuestCDN at the time of bid opening, and that the original bid bond must be mailed and received within 7 calendar days after the bid due date.

Bidders must utilize the Bid Worksheet in the online bidding section of QuestCDN to submit their bid item pricing. The totals from the worksheet are required on page BF-7 of the Submittal Package.

| FORM/ PAGE NO. | COMMENTS | COMPLETE |
|-------------------|--|--|
| BF-4 – BF-5 | a.) Legal name, address, Acknowledgment signature and attestation (if required) | <input type="checkbox"/> |
| BF-6+ | a.) Complete all blanks b.) Legal name required | <input type="checkbox"/> <input type="checkbox"/> |
| BF-7 | a.) Write out bid total or bid totals in words and figures in the blank form space(s) provided. b.) Calculate Textura® Construction Payment Management System Fee from chart on pg. BF-3 and include fee in the Base Bid space provided. | <input type="checkbox"/> <input type="checkbox"/> |
| BF-8 | a.) List all subcontractors who are performing work on this project. | <input type="checkbox"/> |
| BF-9 – BF-10 | a.) Fully complete Form 1A - List of Proposed Subcontractors, Subconsultants, and/or Suppliers ('Base Bid Total' from BF-7 = 'Total Contract Value') | <input type="checkbox"/> |
| BF-11 | a.) Complete all blanks b.) If Addenda have been issued, complete bottom section. | <input type="checkbox"/> <input type="checkbox"/> |
| BF-12 | a.) Complete appropriate sections - signature(s) required. b.) If corporation, then corporate seal required. | <input type="checkbox"/> <input type="checkbox"/> |
| BF-13 | a.) Fully complete Commitment to Participation | <input type="checkbox"/> |
| BF-14 | a.) Fully complete Letter(s) of Intent | <input type="checkbox"/> |
| BF-15 | a.) Fill in all Bid Bond blanks b.) Signatures required c.) Corporate Seal if required d.) Dated e.) Attach Surety Agents Power of Attorney or Certified or cashier's check made out to the Manager of Revenue referencing Bidder's Company and Contract Number. | <input type="checkbox"/> <input type="checkbox"/> <input type="checkbox"/> <input type="checkbox"/> <input type="checkbox"/> |
| BF-16 | a.) Each bidder, as a condition of responsiveness to this solicitation, shall <u>complete and include</u> the "Diversity and Inclusiveness in City Solicitations Information Request Form" with their Bid in QuestCDN. | <input type="checkbox"/> |

Textura® Construction Payment Management System (“Textura”)

Bidder recognizes and agrees that it shall be required to use the Textura® Construction Payment Management System (“Textura”) for this Project to request payment from the City and to pay all first tier subcontractors and suppliers and further record payment to all certified subcontractors or suppliers that are listed for participation towards any assigned program goal. All fees associated with Textura are to be paid by the bidder for billings for work performed. Bidders are required, when preparing a bid, to enter the price of Textura on the line provided for the service on the Bid Worksheet. The fee is all inclusive of all subcontractor, project and subscription fees associated with Textura. The bidder will calculate the fee based on their Base Bid Total (including Force Accounts and Allowances but not including any alternates, if applicable) and the table below, and then include it on the line item provided in the bid form labeled “Textura® Fee”. This expense becomes part of the contract and billable to the City. All costs including, but not limited to, costs associated with training, entering data, and/or utilizing Textura other than the Textura Construction Payment Management System Fee are overhead and shall not be reimbursed by the City. Bidder will be responsible for any tax on the Textura fee. As with other taxes, the City will not reimburse bidder for this cost and therefore this cost should be included in bidder’s bid. Textura will invoice the awarded bidder directly.

| Project Value | Project Fee (GC + Sub Usage) |
|----------------------------------|---------------------------------|
| \$100,000 – 249,999.99 | \$780 |
| \$250,000 - \$499,999.99 | \$1,625 |
| \$500,000 - \$999,999.99 | \$3,250 |
| \$1,000,000 - \$2,999,999.99 | \$5,850 |
| \$3,000,000 - \$4,999,999.99 | \$9,100 |
| \$5,000,000 - \$9,999,999.99 | \$12,220 |
| \$10,000,000 - \$19,999,999.99 | \$20,345 |
| \$20,000,000 - \$49,999,999.99 | \$32,500 |
| \$50,000,000 - \$99,999,999.99 | \$48,750 |
| \$100,000,000 - \$199,999,999.99 | \$69,095 |

For more information:

<http://www.denvergov.org/content/denvergov/en/contract-administration/bidding-process.html>

[REMAINDER OF PAGE INTENTIONALLY LEFT BLANK]

**CITY AND COUNTY OF DENVER
DEPARTMENT OF TRANSPORTATION AND INFRASTRUCTURE**

BID FORM AND SUBMITTAL PACKAGE ACKNOWLEDGMENT

CONTRACT NO. 202263315

CONNECTING AURARIA

BIDDER: Hamon Infrastructure, Inc.
(Legal Name per Colorado Secretary of State)

ADDRESS: 5670 Franklin St
Denver, CO 80216

CONTACT PERSON FOR ALL MATTERS RELATING TO THIS DOCUMENT

NAME: Ryan Mastrianni **TITLE:** Controller & Vice-Secretary
EMAIL: rmastrianni@hamoninfrastructure.com **PHONE NUMBER:** 303.297.0340

AUTHORIZED ELECTRONIC SIGNATORY

NAME: Ryan Mastrianni
EMAIL: rmastrianni@hamoninfrastructure.com

The undersigned bidder states that the undersigned bidder has received and had an opportunity to fully and thoroughly examine a complete set of the Contract Documents for **Contract No. 202263315 - Connecting Auraria**, made available to the undersigned bidder pursuant to Notice of Invitation for Bids dated June 6, 2022.

The undersigned bidder acknowledges that a complete and final set of the Contract Documents for the referenced Project, the components of which are identified below, are bound and maintained as the record set of Contract Documents by the Contract Administration Division of the Department of Transportation and Infrastructure and that this Record Set is available for examination by the undersigned bidder.

The undersigned bidder, having thoroughly examined each of the components identified below and contained in Contract Documents, **HEREBY SUBMITS THIS BID FORM AND SUBMITTAL PACKAGE**, fully understanding that the Contract Documents, as defined in Paragraph 1 of the contract, including this executed Bid Form and Submittal Package, constitute all of the terms, conditions and requirements upon which this submission is based and further understanding that, by submission of this Bid Form and Submittal Package, the City shall rely on the representations and commitments of the undersigned bidder contained herein.

The following completed documents comprising this Bid Form and Submittal Package will be included with and, by this reference, are expressly incorporated into the Contract Documents specified at Paragraph 1 of the Contract:

- Bid Form and Submittal Package Acknowledgment Form
- Bid Form
- List of Proposed Minority/Women Owned Business Enterprise(s)
- Commitment to Minority/Women Owned Business Enterprise Participation
- Minority/Women Owned Business Enterprise(s) of Intent
- Letter of Intent
- Bid Bond
- Certificate of Insurance

The following designated documents constitute that portion of the Contract Documents made available by the Notice of Invitation for Bids, but not included in the Bid Form and Submittal Package:

- Notice of Invitation for Bids
- Instructions to Bidders
- Addenda (as applicable)
- Equal Employment Opportunity Provisions (Appendix A and Appendix F)
- Contract Form
- General Contract Conditions
- Special Contract Conditions
- Performance and Payment Bond
- Notice to Apparent Low Bidder
- Notice to Proceed
- Contractor's Certification of Payment Form
- Final/Partial Release and Certificate of Payment
- Certificate of Contract Receipt
- Change Orders (as applicable)
- Federal Requirements (as applicable)
- Prevailing Wage Rate Schedule(s)
- Technical Specifications
- Contract Drawings
- Accepted Shop Drawings

The undersigned bidder expressly assumes responsibility for the complete contents of these designated documents as bound together with the Bid Form and Submittal Package submitted herewith and designated the Contract Documents.

IN WITNESS WHEREOF, the undersigned bidder has signed personally or by duly authorized officer or agent and duly attested.

BIDDER:

ATTEST:

Name: Hamon Infrastructure, Inc.

By: Ryan Mastrianni

Title: Controller & Vice-Secretary

By: Krystle Sanchez
Krystle Sanchez, Vice Treasurer

[SEAL]

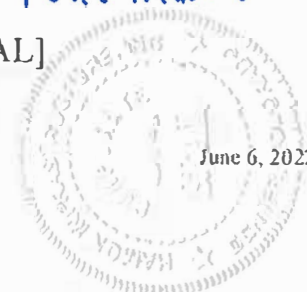

**CITY AND COUNTY OF DENVER
DEPARTMENT OF TRANSPORTATION AND INFRASTRUCTURE**

BID FORM

CONTRACT NO. 202263315

CONNECTING AURARIA

BIDDER: Hamon Infrastructure, Inc.
(Legal Name per Colorado Secretary of State)

TO: The Manager of the Department of Transportation and Infrastructure
City and County of Denver
c/o Contract Administration
201 West Colfax, Dept. 614
Denver, Colorado 80202

The Undersigned Bidder, having examined the plans, technical specifications, and remainder of the proposed Contract Documents as designated and enumerated in the General and Special Contract Conditions and any and all addenda thereto; having investigated the location of and conditions affecting the proposed Work; and being acquainted with and fully understanding the extent and character of the Work covered by this bid, and all factors and conditions affecting or which may be affected by Work, HEREBY SUBMITS THIS BID, pursuant to an advertisement of a Notice of Invitation for Bids as published on **June 6, 2022**, to furnish all required materials, tools, appliances, equipment and plant; to perform all necessary labor and to undertake and complete: **Contract No. 202263315 - Connecting Auraria**, in Denver, Colorado, in full accordance with and conformity to the Plans, Technical Specifications, and Contract Documents hereto attached or by reference made a part hereof, at and for the following price(s) set forth on this Bid Form.

The following documents, which taken as a whole constitute the Contract Documents for this Project, and which are incorporated herein, by reference, were made available to the Bidder as provided in the Advertisement of Notice of Invitation for Bids, were received by the bidder, and form the basis for this bid:

Advertisement of Notice of Invitation for Bids
Instructions to Bidders
Commitment to MWBE Participation
Article III, Divisions 1 and 3 of Chapter 28, D.R.M.C.
Bid Bond
Addenda (as applicable)
Equal Employment Opportunity Provisions (Appendix A and Appendix F)
Bid Form
Contract Form
General Contract Conditions
Special Contract Conditions
Performance and Payment Bond

Notice to Apparent Low Bidder
Notice to Proceed
Contractor's Certification of Payment Form
Final/Partial Release and Certificate of Payment
Certificate of Contract Receipt
Change Orders (as applicable)
Federal Requirements (as applicable)
Prevailing Wage Rate Schedule(s)
Technical Specifications
Contract Drawing
Accepted Shop Drawings
Certificate of Insurance

| Connecting Auraria | | | | | | 300 Days | Hamon Infrastructure, Inc.: Great American Insurance Company | |
|------------------------|--|------|-------|--------------|--------------|--------------|--|--|
| Contract No. 202263315 | | | | | | | | |
| Bid Item | Description | Qty | Units | Unit Cost | Total Cost | Unit Bid | Total Bid | |
| 201-00001 | CLEARING AND GRUBBING | LS | 1 | \$2,500.00 | \$2,500.00 | \$75,000.00 | \$75,000.00 | |
| 202-00001 | REMOVAL OF STRUCTURE | EACH | 1 | \$250,000.00 | \$250,000.00 | \$225,000.00 | \$225,000.00 | |
| 202 | REMOVAL OF TREE GRATE | EACH | 4 | \$100.00 | \$400.00 | \$675.00 | \$2,700.00 | |
| 202 | REMOVAL OF BANNER POLE | EACH | 17 | \$250.00 | \$4,250.00 | \$175.00 | \$2,975.00 | |
| 202 | REMOVAL OF BIKE RACK | EACH | 7 | \$150.00 | \$1,050.00 | \$265.00 | \$1,855.00 | |
| 202 | REMOVAL OF PLANTER POT | EACH | 20 | \$150.00 | \$3,000.00 | \$267.50 | \$5,350.00 | |
| 202 | REMOVAL OF BENCH | EACH | 2 | \$100.00 | \$200.00 | \$615.00 | \$1,230.00 | |
| 202 | REMOVAL OF DELINEATOR | EACH | 11 | \$20.00 | \$220.00 | \$73.00 | \$803.00 | |
| 202 | REMOVAL OF DECORATIVE CROSSWALKS (PAINTED BRICK PATTERN) | SF | 1,268 | \$6.00 | \$7,608.00 | \$3.50 | \$4,438.00 | |
| 202 | REMOVAL OF PRE CAST MEDIANS | LS | 1 | \$6,000.00 | \$6,000.00 | \$1,850.00 | \$1,850.00 | |
| 202-00010 | REMOVAL OF TREE | EACH | 1 | \$1,000.00 | \$1,000.00 | \$500.00 | \$500.00 | |
| 202-00019 | REMOVAL OF INLET | EACH | 5 | \$1,500.00 | \$7,500.00 | \$3,000.00 | \$15,000.00 | |
| 202-00035 | REMOVAL OF PIPE | LF | 118 | \$50.00 | \$5,900.00 | \$100.00 | \$11,800.00 | |
| 202-00175 | REMOVAL OF CONCRETE DRIVEWAY | SY | 125 | \$30.00 | \$3,750.00 | \$70.00 | \$8,750.00 | |
| 202-00200 | REMOVAL OF CONCRETE SIDEWALK | SY | 1,032 | \$25.00 | \$25,800.00 | \$40.00 | \$41,280.00 | |
| 202-00203 | REMOVAL OF CURB AND GUTTER | LF | 868 | \$16.00 | \$13,888.00 | \$20.00 | \$17,360.00 | |
| 202-00206 | REMOVAL OF CONCRETE CURB RAMP | SY | 115 | \$44.00 | \$5,060.00 | \$100.00 | \$11,500.00 | |
| 202-00210 | REMOVAL OF CONCRETE PAVEMENT | SY | 1,789 | \$40.00 | \$71,560.00 | \$51.00 | \$91,239.00 | |
| 202-00220 | REMOVAL OF ASPHALT MAT | SY | 812 | \$25.00 | \$20,300.00 | \$35.00 | \$28,420.00 | |
| 202-00250 | REMOVAL OF PAVEMENT MARKING | SF | 909 | \$6.00 | \$5,454.00 | \$3.50 | \$3,181.50 | |
| 202-00810 | REMOVAL OF GROUND SIGN | EACH | 7 | \$100.00 | \$700.00 | \$151.00 | \$1,057.00 | |
| 202-00821 | REMOVAL OF SIGN PANEL | EACH | 21 | \$60.00 | \$1,260.00 | \$26.00 | \$546.00 | |
| 202-00828 | REMOVAL OF TRAFFIC SIGNAL EQUIPMENT | LS | 1 | \$30,000.00 | \$30,000.00 | \$16,081.00 | \$16,081.00 | |
| 202-010000 | REMOVAL OF FENCE | LF | 7 | \$500.00 | \$3,500.00 | \$100.00 | \$700.00 | |
| 202-04005 | CLEAN VALVE BOX | EACH | 2 | \$300.00 | \$600.00 | \$500.00 | \$1,000.00 | |
| 203-00010 | UNCLASSIFIED EXCAVATION(COMPLETE IN PLACE) | CY | 434 | \$100.00 | \$43,400.00 | \$200.00 | \$86,800.00 | |
| 203-01597 | POTHOLING | HR | 300 | \$250.00 | \$75,000.00 | \$200.00 | \$60,000.00 | |
| 206-00000 | STRUCTURE EXCAVATION | CY | 485 | \$30.00 | \$14,550.00 | \$65.00 | \$31,525.00 | |
| 206-00100 | STRUCTURE BACKFILL (CLASS 1) | CY | 309 | \$60.00 | \$18,540.00 | \$140.00 | \$43,260.00 | |
| 206-00200 | STRUCTURE BACKFILL (CLASS 2) | CY | 70 | \$100.00 | \$7,000.00 | \$125.00 | \$8,750.00 | |
| 206-00360 | MECHANICAL REINFORCEMENT OF SOIL | CY | 309 | \$25.00 | \$7,725.00 | \$75.00 | \$23,175.00 | |
| 206-01781 | SHORING (Area 1) | LS | 1 | \$40,000.00 | \$40,000.00 | \$10,000.00 | \$10,000.00 | |
| 208 | WATER CONTROL | LS | 1 | \$200,000.00 | \$200,000.00 | \$80,000.00 | \$80,000.00 | |
| 208-00200 | EROSION CONTROL | LS | 1 | \$40,000.00 | \$40,000.00 | \$90,000.00 | \$90,000.00 | |
| 210 | RESET PRE CAST MEDIANS | LS | 1 | \$7,500.00 | \$7,500.00 | \$1,000.00 | \$1,000.00 | |
| 210 | RESET TRASH RECEPTACLE | EACH | 2 | \$100.00 | \$200.00 | \$9,000.00 | \$18,000.00 | |
| 210-00827 | RESET PULL BOX | EACH | 4 | \$1,500.00 | \$6,000.00 | \$1,112.00 | \$4,448.00 | |
| 210-00831 | RESET TRAFFIC SIGNAL HEAD | EACH | 2 | \$350.00 | \$700.00 | \$499.00 | \$998.00 | |
| 210-00842 | RESET TRAFFIC SIGNAL MAST ARM | EACH | 1 | \$5,000.00 | \$5,000.00 | \$4,356.00 | \$4,356.00 | |
| 210-04010 | ADJUST MANHOLE | EACH | 1 | \$750.00 | \$750.00 | \$1,200.00 | \$1,200.00 | |
| 210-04050 | ADJUST VALVE BOX | EACH | 2 | \$750.00 | \$1,500.00 | \$650.00 | \$1,300.00 | |
| 212-00005 | SEEDING (NATIVE) | ACRE | 0.05 | \$3,000.00 | \$150.00 | \$10,000.00 | \$500.00 | |
| 212-01200 | LANDSCAPE RESTORATION | LS | 1 | \$20,000.00 | \$20,000.00 | \$20,219.00 | \$20,219.00 | |
| 213-00000 | MULCHING | ACRE | 0.05 | \$5,000.00 | \$250.00 | \$12,000.00 | \$600.00 | |
| 250-00010 | ENVIRONMENTAL HEALTH AND SAFETY MANAGEMENT | LS | 1 | \$7,500.00 | \$7,500.00 | \$4,450.00 | \$4,450.00 | |
| 250-00110 | HEALTH AND SAFETY OFFICER | HR | 20 | \$150.00 | \$3,000.00 | \$115.00 | \$2,300.00 | |
| 250 | MATERIAL SAMPLING AND DELIVERY-CHEMICAL | EACH | 5 | \$500.00 | \$2,500.00 | \$120.00 | \$600.00 | |
| 250 | MATERIAL SAMPLING AND DELIVERY-ASBESTOS | EACH | 20 | \$500.00 | \$10,000.00 | \$90.00 | \$1,800.00 | |
| 250 | MATERIALS MANAGEMENT PLAN SUPERVISOR | HR | 80 | \$150.00 | \$12,000.00 | \$85.00 | \$6,800.00 | |
| 250 | CERTIFIED ASBESTOS BUILDING INSPECTOR | HR | 80 | \$150.00 | \$12,000.00 | \$85.00 | \$6,800.00 | |
| 250 | ASBESTOS CONTAINING MATERIAL ABATEMENT | LS | 1 | \$5,000.00 | \$5,000.00 | \$4,920.00 | \$4,920.00 | |
| 250 | SOLID WASTE EXCAVATION AND TRANSPORTING | CY | 230 | \$200.00 | \$46,000.00 | \$110.00 | \$25,300.00 | |
| 304-06007 | AGGREGATE BASE COURSE (CLASS 6) | CY | 391 | \$50.00 | \$19,550.00 | \$146.91 | \$57,441.81 | |
| 403-00721 | HOT MIX ASPHALT (PATCHING) (ASPHALT) | SY | 18 | \$100.00 | \$1,800.00 | \$300.00 | \$5,400.00 | |
| 412-00600 | CONCRETE PAVEMENT (6 INCH) | SY | 595 | \$70.00 | \$41,650.00 | \$102.25 | \$60,838.75 | |
| 412-00800 | CONCRETE PAVEMENT (8 INCH) | SY | 973 | \$100.00 | \$97,300.00 | \$152.25 | \$148,139.25 | |
| 502-00100 | DRILLING HOLE TO FACILITATE PILE DRIVING | LF | 224 | \$150.00 | \$33,600.00 | \$67.44 | \$15,106.56 | |
| 502-11274 | STEEL PILING (HP 12X74) | LF | 445 | \$120.00 | \$53,400.00 | \$202.32 | \$90,032.40 | |
| 503-00024 | DRILLED SHAFT (24 INCH) | LF | 28 | \$675.00 | \$18,900.00 | \$478.00 | \$13,384.00 | |
| 503-00036 | DRILLED SHAFT (36 INCH) | LF | 52 | \$750.00 | \$39,000.00 | \$480.00 | \$24,960.00 | |
| 504 | CONCRETE PLANTER WALL | LF | 189 | \$50.00 | \$9,450.00 | \$250.00 | \$47,250.00 | |
| 504 | WATER QUALITY PLANTER WALL | LF | 170 | \$50.00 | \$8,500.00 | \$225.00 | \$38,250.00 | |
| 506-00212 | RIPRAP (12 INCH) | CY | 14 | \$120.00 | \$1,680.00 | \$200.00 | \$2,800.00 | |
| 509-00000 | STRUCTURAL STEEL | LB | 42 | \$6.00 | \$252.00 | \$18.50 | \$777.00 | |

| | | | | | | | |
|-----------|--|------|--------|-------------|--------------|-------------|--------------|
| 514-9999 | FENCE (SPECIAL)(6-18 INCH) | LF | 81 | \$250.00 | \$20,250.00 | \$200.00 | \$16,200.00 |
| 515-0040 | CONCRETE SEALER | SY | 566 | \$20.00 | \$11,320.00 | \$13.00 | \$7,358.00 |
| 519-03035 | PLACE THIN BONDED OVERLAY (POLYESTER CONCRETE) | SY | 363 | \$110.00 | \$39,930.00 | \$92.50 | \$33,577.50 |
| 519-03055 | FURNISH THIN BONDED OVERLAY (POLYESTER CONCRETE) | CF | 205 | \$130.00 | \$26,650.00 | \$177.00 | \$36,285.00 |
| 601-03040 | CONCRETE CLASS D (BRIDGE) | CY | 372 | \$1,000.00 | \$372,000.00 | \$1,050.00 | \$390,600.00 |
| 601-40300 | STRUCTURAL CONCRETE COATING | SY | 313 | \$25.00 | \$7,825.00 | \$54.00 | \$16,902.00 |
| 601-40302 | STRUCTURAL CONCRETE COATING (ANTI-GRAFFITI) | SF | 699 | \$18.00 | \$12,582.00 | \$6.00 | \$4,194.00 |
| 602-00020 | REINFORCING STEEL (EPOXY COATED) | LB | 44,748 | \$1.75 | \$78,309.00 | \$2.00 | \$89,496.00 |
| 603-01155 | 15 INCH REINFORCED CONCRETE PIPE (CIP) | LF | 54 | \$350.00 | \$18,900.00 | \$370.00 | \$19,980.00 |
| 604-13005 | INLET TYPE 13 (5 FOOT) | EACH | 1 | \$6,000.00 | \$6,000.00 | \$17,000.00 | \$17,000.00 |
| 604-13505 | INLET TYPE 13 (DOUBLE) (5 FOOT) | EACH | 1 | \$8,000.00 | \$8,000.00 | \$15,500.00 | \$15,500.00 |
| 604-19110 | INLET TYPE R L 5 (10 FOOT) | EACH | 1 | \$10,000.00 | \$10,000.00 | \$18,000.00 | \$18,000.00 |
| 605 | CONCRETE COLLAR | EACH | 1 | \$2,500.00 | \$2,500.00 | \$4,000.00 | \$4,000.00 |
| 606-11035 | BRIDGE RAIL TYPE 10 MASH | LF | 213 | \$350.00 | \$74,550.00 | \$600.00 | \$127,800.00 |
| 608 | DETECTABLE DIRECTIONAL WARNING TILES | LF | 609 | \$75.00 | \$45,675.00 | \$45.00 | \$27,405.00 |
| 608-00010 | CONCRETE CURB RAMP | SY | 288 | \$140.00 | \$40,320.00 | \$180.00 | \$51,840.00 |
| 608 | DETECTABLE WARNING SURFACE | SF | 150 | \$55.00 | \$8,250.00 | \$38.00 | \$5,700.00 |
| 608 | DETECTABLE WARNING SURFACE (CAST IRON) | SF | 227 | \$55.00 | \$12,485.00 | \$56.00 | \$12,712.00 |
| 609-20010 | CURB AND GUTTER TYPE 2 (SECTION B) | LF | 37 | \$45.00 | \$1,665.00 | \$112.00 | \$4,144.00 |
| 609-21010 | CURB AND GUTTER TYPE 2 (SECTION I-B) | LF | 77 | \$45.00 | \$3,465.00 | \$135.00 | \$10,395.00 |
| 609-21020 | CURB AND GUTTER TYPE 2 (SECTION II-B) | LF | 316 | \$50.00 | \$15,800.00 | \$86.00 | \$27,176.00 |
| 609-71000 | CURB (SPECIAL) | LF | 200 | \$45.00 | \$9,000.00 | \$95.00 | \$19,000.00 |
| 612-00039 | DELINEATOR (FLEXIBLE) (SURFACE MOUNTED) | EACH | 34 | \$60.00 | \$2,040.00 | \$101.00 | \$3,434.00 |
| 612 | PRECAST CONCRETE MEDIAN | EACH | 25 | \$300.00 | \$7,500.00 | \$1,200.00 | \$30,000.00 |
| 613-00100 | 1 INCH ELECTRICAL CONDUIT | LF | 144 | \$15.00 | \$2,160.00 | \$22.00 | \$3,168.00 |
| 613-00100 | 1 INCH ELECTRICAL CONDUIT (PVC) | LF | 100 | \$15.00 | \$1,500.00 | \$22.00 | \$2,200.00 |
| 613-00102 | 1 INCH ELECTRICAL CONDUIT (GALVANIZED RIGID CONDUIT) (SPECIAL) | LF | 100 | \$40.00 | \$4,000.00 | \$47.00 | \$4,700.00 |
| 613-00200 | 2 INCH ELECTRICAL CONDUIT | LF | 802 | \$20.00 | \$16,040.00 | \$36.00 | \$28,872.00 |
| 613-00300 | 3 INCH ELECTRICAL CONDUIT | LF | 1,002 | \$35.00 | \$35,070.00 | \$51.00 | \$51,102.00 |
| 613 | INTERCONNECT 3-INCH ELECTRICAL CONDUIT | LF | 289 | \$35.00 | \$10,115.00 | \$45.00 | \$13,005.00 |
| 613 | PULL BOX TYPE B (TRAFFIC) | EACH | 9 | \$1,100.00 | \$9,900.00 | \$1,715.00 | \$15,435.00 |
| 613 | PULL BOX TYPE C (TRAFFIC COMM) | EACH | 3 | \$1,500.00 | \$4,500.00 | \$2,464.00 | \$7,392.00 |
| 613-10000 | WIRING | LS | 1 | \$30,000.00 | \$30,000.00 | \$17,840.00 | \$17,840.00 |
| 613 | LUMINAIRE (LED) (5300 LUMENS) (55 WATT) | EACH | 8 | \$1,500.00 | \$12,000.00 | \$886.00 | \$7,088.00 |
| 613-50109 | ELECTRIC METER PEDESTAL CABINET AND BASE | EACH | 1 | \$8,000.00 | \$8,000.00 | \$8,051.00 | \$8,051.00 |
| 614-00011 | SIGN PANEL (CLASS I) | SF | 150 | \$35.00 | \$5,250.00 | \$41.00 | \$6,150.00 |
| 614-00012 | SIGN PANEL (CLASS II) | SF | 51 | \$40.00 | \$2,040.00 | \$66.00 | \$3,366.00 |
| 614-00216 | STEEL SIGNPOST (2X2 INCH TUBING) | LF | 47 | \$35.00 | \$1,645.00 | \$23.00 | \$1,081.00 |
| 614-70117 | PEDESTRIAN SIGNAL FACE (16) | EACH | 16 | \$550.00 | \$8,800.00 | \$827.00 | \$13,232.00 |
| 614-70324 | TRAFFIC SIGNAL FACE (8-8-8) | EACH | 4 | \$1,200.00 | \$4,800.00 | \$1,215.00 | \$4,860.00 |
| 614-70336 | TRAFFIC SIGNAL FACE (12-12-12) | EACH | 19 | \$800.00 | \$15,200.00 | \$952.00 | \$18,088.00 |
| 614-72855 | TRAFFIC SIGNAL CONTROLLER CABINET | EACH | 2 | \$25,000.00 | \$50,000.00 | \$48,164.00 | \$96,328.00 |
| 614-81000 | TRAFFIC SIGNAL-LIGHT POLE STEEL | EACH | 4 | \$6,500.00 | \$26,000.00 | \$7,710.00 | \$30,840.00 |
| 614-81120 | TRAFFIC SIGNAL-LIGHT POLE STEEL (1-20 FOOT MAST ARM) | EACH | 1 | \$15,000.00 | \$15,000.00 | \$20,804.00 | \$20,804.00 |
| 614-81125 | TRAFFIC SIGNAL-LIGHT POLE STEEL (1-25 FOOT MAST ARM) | EACH | 1 | \$18,000.00 | \$18,000.00 | \$21,487.00 | \$21,487.00 |
| 614-81150 | TRAFFIC SIGNAL LGHIT POLE STEEL (1-50 FOOT MAST ARM) | EACH | 1 | \$25,000.00 | \$25,000.00 | \$29,609.00 | \$29,609.00 |
| 614-81155 | TRAFFIC SIGNAL LGHIT POLE STEEL (1-55 FOOT MAST ARM) | EACH | 1 | \$25,000.00 | \$25,000.00 | \$30,632.00 | \$30,632.00 |
| 614-84100 | TRAFFIC SIGNAL PEDESTAL POLE ALUMINUM | EACH | 3 | \$1,400.00 | \$4,200.00 | \$3,147.00 | \$9,441.00 |
| 614-86105 | TELEMETRY (FIELD) | EACH | 2 | \$1,500.00 | \$3,000.00 | \$7,363.00 | \$14,726.00 |
| 614 | EMERGENCY VEHICLE TRAFFIC SIGNAL PRIORITY CONTROL SYSTEM | EACH | 2 | \$10,000.00 | \$20,000.00 | \$10,774.00 | \$21,548.00 |
| 614-87333 | CLOSED CIRCUIT TELEVISION CAMERA (TRAFFIC SURVEILLANCE) | EACH | 2 | \$6,500.00 | \$13,000.00 | \$6,439.00 | \$12,878.00 |
| 618-01994 | PRESTRESSED CONCRETE BOX (32" THROUGH 48") | SF | 6,075 | \$110.00 | \$668,250.00 | \$118.25 | \$718,368.75 |
| 623 | HI-POP SPRAY HEAD- 12" | EACH | 116 | \$100.00 | \$11,600.00 | \$45.50 | \$5,278.00 |
| 623 | ELECTRIC CONTROL VALVE- CONVENTIONAL | EACH | 2 | \$750.00 | \$1,500.00 | \$432.00 | \$864.00 |
| 623 | ELECTRIC CONTROL VALVE- TWO WIRE | EACH | 2 | \$650.00 | \$1,300.00 | \$715.00 | \$1,430.00 |
| 623-07500 | SOIL MOISTURE SENSOR | EACH | 2 | \$475.00 | \$950.00 | \$930.00 | \$1,860.00 |
| 623 | RAIN SENSOR | EACH | 1 | \$650.00 | \$650.00 | \$567.00 | \$567.00 |
| 623 | ELECTRIC CONTROLLER- TWO WIRE | EACH | 1 | \$1,250.00 | \$1,250.00 | \$11,325.00 | \$11,325.00 |
| 623 | RP BACKFLOW PREVENTER- 1" | EACH | 1 | \$3,500.00 | \$3,500.00 | \$25,338.00 | \$25,338.00 |
| 623 | BACKFLOW PREVENTER ENCLOSURE | EACH | 1 | \$250.00 | \$250.00 | \$2,500.00 | \$2,500.00 |
| 623 | QUICK COUPLING VALVE | EACH | 3 | \$500.00 | \$1,500.00 | \$340.00 | \$1,020.00 |
| 623 | HYDROMETER- 1" | EACH | 1 | \$550.00 | \$550.00 | \$3,475.00 | \$3,475.00 |
| 623-02008 | MANUAL DRAIN VALVE | EACH | 3 | \$125.00 | \$375.00 | \$378.00 | \$1,134.00 |
| 623-05012 | GATE VALVE- 1-1/2" | EACH | 1 | \$400.00 | \$400.00 | \$550.00 | \$550.00 |
| 623 | HDPE MAINLINE- 1-1/2" | LF | 150 | \$3.50 | \$525.00 | \$52.00 | \$7,800.00 |
| 623 | PVC LATERAL- 1" | LF | 1,000 | \$3.00 | \$3,000.00 | \$13.00 | \$13,000.00 |
| 623 | PVC SLEEVING- 2" | LF | 250 | \$4.00 | \$1,000.00 | \$5.50 | \$1,375.00 |
| 623 | PVC SLEEVING- 4" | LF | 200 | \$8.00 | \$1,600.00 | \$15.85 | \$3,170.00 |
| 623-00165 | DRIP VALVE ASSEMBLY- 1-1/2" | EACH | 1 | \$750.00 | \$750.00 | \$1,250.00 | \$1,250.00 |

| | | | | | | | |
|--|---|------|-------|-------------------------|-------------------------------|-------------------------|-------------------------|
| 623-00162 | SUBSURFACE DRIPLINE | EACH | 575 | \$1.50 | \$862.50 | \$3.00 | \$1,725.00 |
| 623 | DRIP LINE BLOW-OUT STUB ASSEMBLY | EACH | 2 | \$550.00 | \$1,100.00 | \$75.00 | \$150.00 |
| 623 | ARRESTOR WITH GROUNDING PLATE | EACH | 2 | \$750.00 | \$1,500.00 | \$1,080.00 | \$2,160.00 |
| 623 | VALVE DECODER | EACH | 3 | \$500.00 | \$1,500.00 | \$50.00 | \$150.00 |
| 623 | MAXI TWO WIRE CABLE | LF | 150 | \$1.00 | \$150.00 | \$2.50 | \$375.00 |
| 619-00003 | WATER METER- 3/4" | EACH | 1 | \$750.00 | \$750.00 | \$20,000.00 | \$20,000.00 |
| 625-00000 | CONSTRUCTION SURVEYING | LS | 1 | \$100,000.00 | \$100,000.00 | \$125,000.00 | \$125,000.00 |
| 626-01112 | PUBLIC INFORMATION MANAGEMENT (TIER II) | DAY | 175 | \$150.00 | \$26,250.00 | \$75.00 | \$13,125.00 |
| 627-00003 | THERMOPLASTIC PAVEMENT MARKING (INLAID) | SF | 74 | \$30.00 | \$2,220.00 | \$18.50 | \$1,369.00 |
| 627-00008 | MODIFIED EPOXY PAVEMENT MARKING | GAL | 21 | \$500.00 | \$10,500.00 | \$325.00 | \$6,825.00 |
| 627-30405 | PREFORMED THERMOPLASTIC PAVEMENT MARKING (WORD/ SYMBOL) | SF | 854 | \$45.00 | \$38,430.00 | \$18.50 | \$15,799.00 |
| 627-30410 | PREFORMED THERMOPLASTIC PAVEMENT MARKING (XWALK/ STOP LINE) | SF | 1,854 | \$25.00 | \$46,350.00 | \$15.50 | \$28,737.00 |
| 629-01210 | ADJUST MONUMENT BOX | EACH | 1 | \$1,100.00 | \$1,100.00 | \$1,200.00 | \$1,200.00 |
| 630 | TRAFFIC CONTROL | LS | 1 | \$250,000.00 | \$250,000.00 | \$250,000.00 | \$250,000.00 |
| 212-00101 | TREE PROTECTION | EACH | 12 | \$500.00 | \$6,000.00 | \$2,850.00 | \$34,200.00 |
| 213 | WOOD MULCH | CF | 475 | \$3.50 | \$1,662.50 | \$3.50 | \$1,662.50 |
| 214-00000 | 1 YEAR LANDSCAPE MAINTENANCE | LS | 1 | \$10,000.00 | \$10,000.00 | \$5,025.00 | \$5,025.00 |
| 214-00230 | DECIDUOUS TREE (3 INCH CALIPER) | EACH | 9 | \$600.00 | \$5,400.00 | \$1,050.00 | \$9,450.00 |
| 214-00320 | DECIDUOUS SHRUB (2 GALLON CONTAINER) | EACH | 187 | \$30.00 | \$5,610.00 | \$35.00 | \$6,545.00 |
| 214-00350 | DECIDUOUS SHRUB (5 GALLON CONTAINER) | EACH | 65 | \$65.00 | \$4,225.00 | \$65.00 | \$4,225.00 |
| 214-00910 | PERENNIALS (1 GALLON CONTAINER) | EACH | 448 | \$22.00 | \$9,856.00 | \$20.00 | \$8,960.00 |
| 412 | CONCRETE PAVEMENT (6 INCH) (COLORED) | SY | 761 | \$90.00 | \$68,490.00 | \$250.00 | \$190,250.00 |
| 412 | CONCRETE PAVEMENT (8 INCH) (COLORED) | SY | 914 | \$120.00 | \$109,680.00 | \$275.00 | \$251,350.00 |
| 622 | BICYLCE RACK | EACH | 9 | \$1,000.00 | \$9,000.00 | \$1,300.00 | \$11,700.00 |
| 622 | FREESTANDING PLANTER A | EACH | 25 | \$500.00 | \$12,500.00 | \$3,750.00 | \$93,750.00 |
| 622 | FREESTANDING PLANTER B | EACH | 6 | \$500.00 | \$3,000.00 | \$5,425.00 | \$32,550.00 |
| 622 | CIP CONCRETE BENCH SEAT | LF | 132 | \$50.00 | \$6,600.00 | \$381.00 | \$50,292.00 |
| 622 | BENCH TOPPER | EACH | 22 | \$200.00 | \$4,400.00 | \$3,200.00 | \$70,400.00 |
| 622 | STACKED TIMBER BENCH | EACH | 1 | \$2,000.00 | \$2,000.00 | \$45,000.00 | \$45,000.00 |
| 622 | TIMBER BENCH | EACH | 2 | \$2,500.00 | \$5,000.00 | \$10,000.00 | \$20,000.00 |
| 700-70305 | AESTHETICS | A/A | 1 | \$338,000.00 | \$338,000.00 | \$338,000.00 | \$338,000.00 |
| 700-70010 | MINOR CONTRACT REVISIONS | F/A | 1 | \$100,000.00 | Removed | \$100,000.00 | Removed |
| 700-70072 | OBTAIN POWER FROM XCEL | A/A | 1 | \$50,000.00 | \$50,000.00 | \$50,000.00 | \$50,000.00 |
| 700-70175 | UNKNOWN UTILITIES | A/A | 1 | \$25,000.00 | \$25,000.00 | \$25,000.00 | \$25,000.00 |
| 700-70210 | LIGHTING | A/A | 1 | \$100,000.00 | \$100,000.00 | \$100,000.00 | \$100,000.00 |
| 700-70236 | PERMITS | F/A | 1 | \$25,000.00 | \$25,000.00 | \$25,000.00 | \$25,000.00 |
| 700-70245 | UTILITY TAP FEE | F/A | 1 | \$25,000.00 | \$25,000.00 | \$25,000.00 | \$25,000.00 |
| 700-70380 | EROSION CONTROL | A/A | 1 | \$50,000.00 | \$50,000.00 | \$50,000.00 | \$50,000.00 |
| 700-70581 | AIR MONITORING SPECIALIST | A/A | 1 | \$15,000.00 | \$15,000.00 | \$15,000.00 | \$15,000.00 |
| 700-70588 | RACS EXCAVATION, LOADING, AND TRANSPORTATION | A/A | 1 | \$50,000.00 | \$50,000.00 | \$50,000.00 | \$50,000.00 |
| LS1 | MOBILIZATION | LS | 1 | \$486,463.64 | \$486,463.64 | \$359,280.00 | \$359,280.00 |
| LS2 | TESTING/QUALITY CONTROL | LS | 1 | \$75,000.00 | \$75,000.00 | \$98,500.00 | \$98,500.00 |
| Engineers Estimate of Base Bid Total: | | | | | \$5,270,632.64 | | |
| | | | | | BID ITEMS TOTAL AMOUNT | | \$6,333,777.02 |
| | | | | | TEXTURA FEE | | \$12,220.00 |
| | | | | | | | \$6,345,997.02 |

RD

***** Updates Approved by Ryan Mastrianni 8/5/22**

| | |
|---|--|
| Seventy-Five [175] | |
| Sum of estimated cost for item numbers <u>201-00001 through LS2 (One Hundred Ninety One [191] base bid items)</u> and the Textura Fee equals Total Base Bid Amount: | |
| Six Million Eight Hundred and Seven Thousand Nine Hundred | RD |
| Ally Seven Dollars | Six Million Three Hundred Forty Five Thousand Nine Hundred Ninety Seven |
| Dollars and 02 Cents | Dollars (\$ 6,807,997.06 6,345,997.02) |

****Approved by RD/Hamon**

If the Manager mails a written Notice of Apparent Low Bidder, addressed to the Bidder's business address stated on this Bid Form, the Undersigned Bidder shall, in accordance with the Contract Documents, be ready to, and shall, within five (5) days after the date of the Notice: (i) execute the attached form of Contract in conformity with this bid; (ii) furnish the required proofs of insurance; and (iii) furnish the required bond or bonds in the sum of the full amount of this bid, executed by a surety company acceptable to the Manager.

The Great American Insurance Company, a corporation of the State of Ohio, is hereby offered as Surety on said bond. If such surety is not approved by the Manager, another and satisfactory surety company shall be furnished.

Enclosed with this bid is a bid guarantee, as defined in the attached Instructions to Bidders, in the amount of 5% of the total amount bid. The Undersigned Bidder agrees that the entire amount of this bid guarantee is to be paid to and become the property of the City as liquidated damages, and not as a penalty, if: (i) the bid is considered to be the best by the City; (ii) the City notifies the Undersigned Bidder that it is the Apparent Low Bidder; and (iii) the Undersigned Bidder fails to execute the Contract in the form prescribed or to furnish the required bond and proofs of insurance, within five (5) days after the date of such notification.

The following persons, firms or corporations are interested with the Undersigned Bidder in this bid:

Name: _____ Name: _____

Address: _____ Address: _____

If there are no such persons, firms, or corporations, please so state in the following space:

There are no such persons, firms, or corporations interested with the Undersigned Bidder, Hamon Infrastructure, Inc., in this bid.

The Undersigned Bidder proposes to subcontract the following Work in accordance with General Contract Conditions, Title 5, SUBCONTRACTS, and represents that, to the greatest degree practical, all subcontractors known at the time of bid submittal have been identified.

| Item of Work | Percent (%) of Total; Work | Proposed Subcontractor and Address |
|-------------------------------------|----------------------------|---|
| Electrical & Signage | 8 | Interface Communications Inc 5400 Mt Meeker Rd, Suite A, Boulder CO 80301 |
| Drilling | .01 | Ludwig Drilling LLC 704 Topeka Way, Castle Rock, CO 80109 |
| Concrete Stain & Coating | .03 | Quality Linings & Painting Inc 8250 E 40th Ave, Denver, CO 80207 |
| Environmental Health & Safety Mngmt | .01 | Cascade Environmental 7393 S Alton Way, Centennial, CO 80112 |
| Irrigation & Lanscaping | .02 | SaBell's Civil and Landscape LLC 8500 W Bowles Ave #204, Littleton, CO 80123 |
| Milling | .02 | Alpha Milling Company Inc 6015 W 56th Ave, Arvada, CO 80002 |
| Concrete Sealing/Overlay | .1 | ABCO Contracting, Inc 2180 E 74th Pl, Denver, CO 80229 |
| Striping | .1 | S&S Striping and Signage 14415 Shadow Wood Ct, Brighton, CO 80603 |
| Flatwork and Asphalt | 11% | Loya Construction, Inc PO Box 211555, Denver, CO 80221 |
| Traffic Control & Signage | 3% | Rocky Mountain Signing Company 10335 South Progress Way, Parker, CO 80134 |
| Pile Driving | 2% | Lobato Construction LLC 1333 W 120th Ave, Suite 306, Westminster, CO 80234 |
| Girder Set | 1% | RMS Cranes 1961 E 64th Ave, Denver, CO 80229 |
| Potholing | .1% | Colorado Utility Finders PO Box 7506, Loveland, CO 80537 |
| Rebar Tying | .1 | Denver Rebar 6440 S Abilene St, Centennial, CO 80111 |

(Copy this page if additional room is required.)



DIVISION OF SMALL BUSINESS OPPORTUNITY (DSBO)

1A - LIST OF PROPOSED SUBCONTRACTORS, SUBCONSULTANTS, AND/OR SUPPLIERS

City & County of Denver Contract No.: 202263315

The undersigned proposes to utilize all listed firms. Any certified firm listed must be certified by the City and County of Denver and a **Letter of Intent (LOI)** submitted for each. If additional pages are required, please copy and attach the second page. This form must be updated and submitted to DSBO when subcontractors, subconsultants, and/or suppliers are added throughout the contract duration.

| Contractor/Consultant | | |
|---|--|--|
| Name of Firm: Hamon Infrastructure, Inc. | | <input type="checkbox"/> MWBE (v) <input type="checkbox"/> SBE (v) <input type="checkbox"/> DBE (v) <input type="checkbox"/> EBE (v) |
| Firm's Representative: Ryan Mastrianni | | |
| Signature: | | Date: <u>7-14-2022</u> |
| Address: 5670 Franklin St | | |
| City: Denver | State: CO | Zip: 80216 |
| Phone: 303.297.0340 | Email: rmastrianni@hamoninfrastructure.com | |
| Total Contract Value \$: 6,807,997 | | Self-Performing Contract Value \$: |

***Approved updated contract value \$6,345,997.02**

| Subcontractors, Subconsultants, and/or Suppliers | |
|--|---|
| Name of Firm: <u>Loya Construction</u> | <input checked="" type="checkbox"/> MWBE (v) <input type="checkbox"/> SBE (v) <input type="checkbox"/> DBE (v) <input type="checkbox"/> EBE (v) |
| Firm's Representative: | |
| Phone: | Email: |
| Type of Service: <u>Flatwork & Asphalt</u> | Contract Value \$: <u>815,000</u> |
| Anticipated Start Date: | Anticipated Completion Date: |

| | |
|--|---|
| Name of Firm: <u>Sebells Civil & Landscape LLC</u> | <input checked="" type="checkbox"/> MWBE (v) <input type="checkbox"/> SBE (v) <input type="checkbox"/> DBE (v) <input type="checkbox"/> EBE (v) |
| Firm's Representative: | |
| Phone: | Email: |
| Type of Service: <u>landscape</u> | Contract Value \$: <u>119,465</u> |
| Anticipated Start Date: | Anticipated Completion Date: |

| | |
|---|---|
| Name of Firm: <u>JA Hall Enterprises</u> | <input checked="" type="checkbox"/> MWBE (v) <input type="checkbox"/> SBE (v) <input type="checkbox"/> DBE (v) <input type="checkbox"/> EBE (v) |
| Firm's Representative: | |
| Phone: | Email: |
| Type of Service: <u>Material Supplier</u> | Contract Value \$: <u>156,000</u> |
| Anticipated Start Date: | Anticipated Completion Date: |

| | |
|---|-------------------------------------|
| Name of Firm: <u>Bett Engineering</u> <input checked="" type="checkbox"/> MWBE (v) <input type="checkbox"/> SBE (v) <input type="checkbox"/> DBE (v) <input type="checkbox"/> EBE (v) | |
| Firm's Representative: | |
| Phone: | Email: |
| Type of Service: <u>Testing</u> | Contract Value \$: <u>80,000.00</u> |
| Anticipated Start Date: | Anticipated Completion Date: |

| | |
|---|-----------------------------------|
| Name of Firm: <u>Rocky Mtn Signing Co</u> <input checked="" type="checkbox"/> MWBE (v) <input type="checkbox"/> SBE (v) <input type="checkbox"/> DBE (v) <input type="checkbox"/> EBE (v) | |
| Firm's Representative: | |
| Phone: | Email: |
| Type of Service: <u>Traffic Control</u> | Contract Value \$: <u>130,000</u> |
| Anticipated Start Date: | Anticipated Completion Date: |

| | |
|--|------------------------------|
| Name of Firm: <input type="checkbox"/> MWBE (v) <input type="checkbox"/> SBE (v) <input type="checkbox"/> DBE (v) <input type="checkbox"/> EBE (v) | |
| Firm's Representative: | |
| Phone: | Email: |
| Type of Service: | Contract Value \$: |
| Anticipated Start Date: | Anticipated Completion Date: |

| | |
|--|------------------------------|
| Name of Firm: <input type="checkbox"/> MWBE (v) <input type="checkbox"/> SBE (v) <input type="checkbox"/> DBE (v) <input type="checkbox"/> EBE (v) | |
| Firm's Representative: | |
| Phone: | Email: |
| Type of Service: | Contract Value \$: |
| Anticipated Start Date: | Anticipated Completion Date: |

| | |
|--|------------------------------|
| Name of Firm: <input type="checkbox"/> MWBE (v) <input type="checkbox"/> SBE (v) <input type="checkbox"/> DBE (v) <input type="checkbox"/> EBE (v) | |
| Firm's Representative: | |
| Phone: | Email: |
| Type of Service: | Contract Value \$: |
| Anticipated Start Date: | Anticipated Completion Date: |

| | |
|--|------------------------------|
| Name of Firm: <input type="checkbox"/> MWBE (v) <input type="checkbox"/> SBE (v) <input type="checkbox"/> DBE (v) <input type="checkbox"/> EBE (v) | |
| Firm's Representative: | |
| Phone: | Email: |
| Type of Service: | Contract Value \$: |
| Anticipated Start Date: | Anticipated Completion Date: |

The undersigned Bidder acknowledges the right of the City to reject any or all bids submitted, to waive informalities in bids and to re-advertise this Project for bids.

The undersigned certifies that it has carefully checked all works and figures and all statements made in these Bid Forms.

This bid is submitted upon the declaration that neither, I (we), nor, to the best of my (our) knowledge, none of the members of my (our) firm or company have either directly or indirectly entered into any agreement, participated in any collusion or otherwise taken any action in restraint of free competitive bidding in connection with this bid.

Business Address of Bidder: 5670 Franklin St

City, State, Zip Code: Denver, CO 80216

Telephone Number of Bidder: 303.297.0340

Fax No. 303.296.9601

Social Security or Federal Employer ID Number of Bidder: EIN # 84-1129267

Name and location of the last work of this kind herein contemplated upon which the Bidder was engaged:

Cottonwood Drive - Town of Parker, Parker, CO 80138

For information relative thereto, please refer to:

Name: Chris Hudson

Title: Deputy Director of Engineering

Address: 20120 East Main St., Parker CO 80138

The undersigned acknowledges receipt, understanding, and full consideration of the following addenda to the Contract Documents:

Addenda Number 1 Date June 28, 2022

Addenda Number _____ Date _____

Addenda Number _____ Date _____

Dated this 14 day of July, 2022.

Signature of Bidder:

If an Individual: _____ doing business
as _____

If a Partnership: _____
by: _____ General Partner.

If a Corporation: Hamon Infrastructure, Inc.
a Colorado Corporation Corporation,
by: [Signature] Vice-
Michael Waiters its President.

Attest:
[Signature]
Vice-Secretary, Ryan Mastrianni (Corporate Seal)

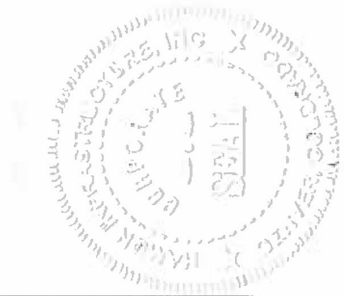

If a Joint Venture, signature of all Joint Venture participants.

Firm: _____
Corporation (), Partnership () or () Limited Liability Company

By: _____ (If a Corporation)
Attest: _____
Title: _____ Secretary (Corporate Seal)

Firm: _____
Corporation (), Partnership () or () Limited Liability Company

By: _____ (If a Corporation)
Attest: _____
Title: _____ Secretary (Corporate Seal)

Firm: _____
Corporation (), Partnership () or () Limited Liability Company

By: _____ (If a Corporation)
Attest: _____
Title: _____ Secretary (Corporate Seal)



**DIVISION OF SMALL BUSINESS OPPORTUNITY (DSBO)
LETTER OF INTENT (LOI)**

Contract No.: 202263315

Project Name: Connecting Auraria

A. The undersigned Bidder/Proposer intends to engage the undersigned MWBE, SBE, EBE or DBE to perform work if awarded the contract. This Letter of Intent Must be Signed by the Bidder/Proposer and MWBE, SBE, EBE or DBE. Certified self-performing Prime must complete both sections A and B. If the MWBE, SBE, EBE or DBE is a lower tier, section C must be completed and signed by the firm directly utilizing the certified firm.

| | | |
|--|--|---|
| Bidder/Proposer (Name of Firm): Hamon Infrastructure | | Self-Performing: <input checked="" type="checkbox"/> Yes <input type="checkbox"/> No |
| Firm's Representative: Ryan Mastrianni | Title: Vice Secretary | |
| Signature (Firm's Representative): | Date: 7-14-22 | |
| Address: 5670 Franklin Street | | |
| City: Denver | State: CO | Zip: 80216 |
| Phone: 303.297.0340 | Email: rmastrianni@hamoninfrastructure.com | |

B. The Following Section is To Be Completed by the MWBE, SBE, EBE or DBE, at any tier. Identify the scope of the work and NAICS code(s) to be performed and/or supply item that will be provided by the MWBE, SBE, EBE or DBE.

| | | |
|--|--|--|
| Name of Firm: <u>Loya Construction Inc</u> | | <input checked="" type="checkbox"/> MWBE(V) <input checked="" type="checkbox"/> SBE(V) <input type="checkbox"/> EBE(V) <input checked="" type="checkbox"/> DBE(V) |
| Firm's Representative: <u>Yesenia Loya</u> | Title: <u>President</u> | |
| Signature: | Date: <u>7/13/22</u> | |
| Address: <u>7070 Dahlia St.</u> | | |
| City: <u>Commerce city</u> | State: <u>CO</u> | Zip: <u>80022</u> |
| Phone: <u>720-585-1311</u> | Email: <u>loyaconstruction@yahoo.com</u> | |
| Scope of Work: <u>Concrete Flatwork</u> | | |

NAICS Code(s): 237310

The Bidder/Proposer intends to utilize the aforementioned MWBE, SBE, EBE or DBE for the Work/Supply described above. The cost of the work and percentage of the total subcontractor MWBE, SBE, EBE or DBE bid amount is:

| | | |
|----------------------|-------|---|
| \$ <u>815,000.00</u> | 11.97 | % |
|----------------------|-------|---|

C. Lower Tier Utilization: If the certified firm is not a direct first tier subcontractor, subconsultant, and/or supplier to the Bidder/Proposer, please indicate the name of the firm that is utilizing the certified firm:

| | |
|------------------------|--------|
| Name of Firm: | |
| Firm's Representative: | Title: |
| Signature: | Date: |

If the above-named Bidder/Proposer is not determined to be the successful Bidder/Proposer, this **Letter of Intent** shall be null and void.

DSBO Version 1 Last Revised: June 5, 2020



DIVISION OF SMALL BUSINESS OPPORTUNITY (DSBO) COMMITMENT TO MWBE PARTICIPATION

This page must be completed by all Bidders/Proposers to indicate their commitment towards satisfying the MWBE participation goal. The commitment will be incorporated into the contract and thereby the selected Bidder/Proposer's will be held to that commitment. (Please check the appropriate box):

COMPLETE IF YOU ARE A NON MWBE PRIME:

The City and County of Denver has specified a 19 % MWBE Participation goal on this project. The Bidder/Proposer is committed to meeting 20.49 % MWBE Participation on the contract.

COMPLETE IF YOU ARE A MWBE PRIME:

The City and County of Denver has specified a _____ % MWBE Participation goal on this project. The Bidder/Proposer is a certified MWBE with the City and County of Denver and is committed to meeting _____ % MWBE Participation on the contract.

COMPLETE IF YOU ARE UNABLE TO MEET PROJECT GOAL:

The City and County of Denver has specified a _____ % MWBE Participation goal on this project. The Bidder/Proposer is unable to meet this project goal but is committed to a _____ % MWBE Participation on the contract. The Bidder/Proposer must make adequate good faith efforts to meet this goal in order to be deemed responsive. The Bidder/Proposer must submit a detailed statement and documentation of their good faith efforts. Award of the contract will be conditioned on meeting the requirements of this section, in accordance of Chapter 28 of the D.R.M.C. to the Division of Small Business Opportunity.

The undersigned Bidder/Proposer hereby agrees and understands that they must comply with their MWBE commitments in this project in conformity with the Requirements, Terms, and Conditions of this MWBE Procurement/Contract Language.

Bidder/Proposer (Name of Firm): Hamon Infrastructure, Inc.

Firm's Representative: Ryan Mastrianni

Title: Controller & Vice-Secretary

Signature (Firm's Representative): 

Date: 8-8-22

Address: 5670 Franklin St

City: Denver

State: CO

Zip: 80216

Phone: 303.297.0340

Email: rmastrianni@hamoninfrastructure.com

Revised 7/14/2020



**DIVISION OF SMALL BUSINESS OPPORTUNITY (DSBO)
LETTER OF INTENT (LOI)**

Contract No.: 202263315

Project Name: Connecting Auraria

A. The undersigned Bidder/Proposer intends to engage the undersigned MWBE, SBE, EBE or DBE to perform work if awarded the contract. This Letter of Intent Must be Signed by the Bidder/Proposer and MWBE, SBE, EBE or DBE. Certified self-performing Prime must complete both sections A and B. If the MWBE, SBE, EBE or DBE is a lower tier, section C must be completed and signed by the firm directly utilizing the certified firm.

Bidder/Proposer (Name of Firm): Hamon Infrastructure

Self Performing:

 Yes No

Firm's Representative: Ryan Mastrianni

Title: Vice Secretary

Signature (Firm's Representative):

Date: 7-14-22

Address: 5670 Franklin Street

City: Denver

State: CO

Zip: 80216

Phone: 303-297-0340

Email: rmastranni@hamoninfrastructure.com

B. The Following Section is To Be Completed by the MWBE, SBE, EBE or DBE, at any tier. Identify the scope of the work and NAICS code(s) to be performed and/or supply item that will be provided by the MWBE, SBE, EBE or DBE.

Name of Firm: SaBell's Civil and Landscape LLC

 MWBE(V) SBE(V) EBE(V) DBE(V)

Firm's Representative: Laura Strauch

Title: Owner

Signature:

Date: 7/12/22

Address: 8500 W Bowles Ave Ste 204

City: Littleton,

State: CO.

Zip: 80123

Phone: 303-505-3857

Email: lauras@scicontractor.com

Scope of Work: Landscape and Irrigation

NAICS Code(s): 237310, 561730

The Bidder/Proposer intends to utilize the aforementioned MWBE, SBE, EBE or DBE for the Work/Supply described above. The cost of the work and percentage of the total subcontractor MWBE, SBE, EBE or DBE bid amount is:

\$ 119,465.00

1.75

%

C. Lower Tier Utilization: If the certified firm is not a direct first tier subcontractor, subconsultant, and/or supplier to the Bidder/Proposer, please indicate the name of the firm that is utilizing the certified firm:

Name of Firm:

Firm's Representative:

Title:

Signature:

Date:

If the above-named Bidder/Proposer is not determined to be the successful Bidder/Proposer, this Letter of Intent shall be null and void.

DSBO Version 1 Last Revised: June 5, 2020



**DIVISION OF SMALL BUSINESS OPPORTUNITY (DSBO)
LETTER OF INTENT (LOI)**

Contract No.: 202263315

Project Name: Connecting Auraria

A. The undersigned Bidder/Proposer intends to engage the undersigned MWBE, SBE, EBE or DBE to perform work if awarded the contract. This Letter of Intent Must be Signed by the Bidder/Proposer and MWBE, SBE, EBE or DBE. Certified self-performing Prime must complete both sections A and B. If the MWBE, SBE, EBE or DBE is a lower tier, section C must be completed and signed by the firm directly utilizing the certified firm.

Bidder/Proposer (Name of Firm): Hamon Infrastructure

Self-Performing:
 Yes No

Firm's Representative: Ryan Mastrianni

Title: Vice Secretary

Signature (Firm's Representative):

Date:

7-14-22

Address: 5670 Franklin Street

City: Denver

State: CO

Zip: 80216

Phone: 303-297-0340

Email: rmastrianni@hamoninfrastructure.com

B. The Following Section is To Be Completed by the MWBE, SBE, EBE or DBE, at any tier. Identify the scope of the work and NAICS code(s) to be performed and/or supply item that will be provided by the MWBE, SBE, EBE or DBE.

Name of Firm: JA Hall Industries, Inc.

 MWBE(v) SBE(v)
 EBE(v) DBE(v)

Firm's Representative: Audrey Etta Hall

Title: President / CEO

Signature: Audrey Etta Hall

Date: 7/13/2022

Address: 12412 York St

City: Thornton

State: CO

Zip: 80241

Phone: 928-271-0809

Email: audrey@jahallindustries.com

Scope of Work: Supply of:

NAICS Code(s): 423310 / 423510

The Bidder/Proposer intends to utilize the aforementioned MWBE, SBE, EBE or DBE for the Work/Supply described above. The cost of the work and percentage of the total subcontractor MWBE, SBE, EBE or DBE bid amount is:

\$ 156,000.00

2.29

%

C. Lower Tier Utilization: If the certified firm is not a direct first tier subcontractor, subconsultant, and/or supplier to the Bidder/Proposer, please indicate the name of the firm that is utilizing the certified firm:

Name of Firm:

Firm's Representative:

Title:

Signature:

Date:

If the above-named Bidder/Proposer is not determined to be the successful Bidder/Proposer, this Letter of Intent shall be null and void.

DSBO Version 1 Last Revised: June 5, 2020



**DIVISION OF SMALL BUSINESS OPPORTUNITY (DSBO)
LETTER OF INTENT (LOI)**

Contract No.: 202263315

Project Name: Connecting Auraria

A. The undersigned Bidder/Proposer intends to engage the undersigned MWBE, SBE, EBE or DBE to perform work if awarded the contract. This Letter of Intent Must be Signed by the Bidder/Proposer and MWBE, SBE, EBE or DBE. Certified self-performing Prime must complete both sections A and B. If the MWBE, SBE, EBE or DBE is a lower tier, section C must be completed and signed by the firm directly utilizing the certified firm.

Bidder/Proposer (Name of Firm): Hamon Infrastructure

Self-Performing:
 Yes No

Firm's Representative: Ryan Mastrianni

Title: Vice Secretary

Signature (Firm's Representative):

Date: 7-14-22

Address: 5670 Franklin Street

City: Denver

State: CO

Zip: 80216

Phone: 303.297.0340

Email: rmastrianni@hamoninfrastructure.com

B. The Following Section is To Be Completed by the MWBE, SBE, EBE or DBE, at any tier. Identify the scope of the work and NAICS code(s) to be performed and/or supply item that will be provided by the MWBE, SBE, EBE or DBE.

Name of Firm: Best Engineering

 MWBE(v) SBE(v)
 EBE(v) DBE(v)

Firm's Representative: Corynne Cromwell

Title: Construction Services Manager

Signature:

Date: 7-12-2022

Address: 1393 South Inca Street

City: Denver

State: Colorado

Zip: 80223

Phone: 303-238-1770

Email: cori@bestengineeringusa.com

Scope of Work: Materials Testing

NAICS Code(s): 541380

The Bidder/Proposer intends to utilize the aforementioned MWBE, SBE, EBE or DBE for the Work/Supply described above. The cost of the work and percentage of the total subcontractor MWBE, SBE, EBE or DBE bid amount is:

\$ 60,000

1.18

%

C. Lower Tier Utilization: If the certified firm is not a direct first tier subcontractor, subconsultant, and/or supplier to the Bidder/Proposer, please indicate the name of the firm that is utilizing the certified firm:

Name of Firm:

Firm's Representative:

Title:

Signature:

Date:

If the above-named Bidder/Proposer is not determined to be the successful Bidder/Proposer, this Letter of Intent shall be null and void.

DSBO Version 1 Last Revised: June 5, 2020



**DIVISION OF SMALL BUSINESS OPPORTUNITY (DSBO)
LETTER OF INTENT (LOI)**

Contract No.: 202263315

Project Name: Connecting Auraria

A. The undersigned Bidder/Proposer intends to engage the undersigned MWBE, SBE, EBE or DBE to perform work if awarded the contract. This Letter of Intent Must be Signed by the Bidder/Proposer and MWBE, SBE, EBE or DBE. Certified self-performing Prime must complete both sections A and B. If the MWBE, SBE, EBE or DBE is a lower tier, section C must be completed and signed by the firm directly utilizing the certified firm.

| | | |
|--|--|---|
| Bidder/Proposer (Name of Firm): Hamon Infrastructure | | Self-Performing: <input checked="" type="checkbox"/> Yes <input type="checkbox"/> No |
| Firm's Representative: Ryan Matrianni | Title: Vice Secretary | |
| Signature (Firm's Representative): | Date: 7-14-22 | |
| Address: 5670 Franklin Street | | |
| City: Denver | State: CO | Zip: 80216 |
| Phone: 303-297-0340 | Email: rmatranni@hamoninfrastructure.com | |

B. The Following Section is To Be Completed by the MWBE, SBE, EBE or DBE, at any tier. Identify the scope of the work and NAICS code(s) to be performed and/or supply item that will be provided by the MWBE, SBE, EBE or DBE.

| | | |
|--|--|------------|
| Name of Firm: Rocky Mountain Signing Company | <input checked="" type="checkbox"/> MWBE(v) <input checked="" type="checkbox"/> SBE(v) <input type="checkbox"/> EBE(v) <input checked="" type="checkbox"/> DBE(v) | |
| Firm's Representative: Patrick Tryon | Title: Vice President | |
| Signature: | Date: 07-12-2022 | |
| Address: 10335 South Progress Way | | |
| City: Parker | State: CO | Zip: 80134 |
| Phone: 303-994-7856 | Email: pat.tryon@team-rms.com | |
| Scope of Work: Traffic Control | | |

NAICS Code(s): 237310, 238990, 425120, 484220, 532412, 561990

The Bidder/Proposer intends to utilize the aforementioned MWBE, SBE, EBE or DBE for the Work/Supply described above. The cost of the work and percentage of the total subcontractor MWBE, SBE, EBE or DBE bid amount is:

| | | |
|---------------|------|---|
| \$ 130,000.00 | 1.91 | % |
|---------------|------|---|

C. Lower Tier Utilization: If the certified firm is not a direct first tier subcontractor, subconsultant, and/or supplier to the Bidder/Proposer, please indicate the name of the firm that is utilizing the certified firm:

| | |
|------------------------|--------|
| Name of Firm: | |
| Firm's Representative: | Title: |
| Signature: | Date: |

If the above-named Bidder/Proposer is not determined to be the successful Bidder/Proposer, this Letter of Intent shall be null and void.

DSBO Version I Last Revised: June 5, 2020

CITY AND COUNTY OF DENVER
DEPARTMENT OF TRANSPORTATION AND INFRASTRUCTURE

BID BOND

KNOW ALL MEN BY THESE PRESENTS:

THAT Hamon Infrastructure, Inc., as Principal, and Great American Insurance Company, a corporation organized and existing under and by virtue of the laws of the State of OH, and authorized to do business within the State of Colorado, as Surety, are held and firmly bound unto the City and County of Denver, Colorado, as Oblige, in full and just sum of Five Percent of the Total Amount Bid Dollars, (\$ 5%), lawful money of the United States, for the payment of which sum, well and truly to be made, we bind ourselves, our heirs, executors, administrators, successors and assigns, jointly and severally, firmly by these presents:

WHEREAS, the said Principal is herewith submitting its bid, dated July 14th, 2022, for the construction of: **Contract No. 202263315 - Connecting Auraria**, as set forth in detail in the Contract Documents for the City and County of Denver, Colorado, and said Oblige has required as a condition for receiving said bid that the Principal deposit specified bid security in the amount of not less than five percent (5%) of the amount of said bid, as it relates to work to be performed for the City, conditioned that in event of failure of the Principal to execute the Contract, for such construction and furnish required Performance and Payment Bond if the contract is offered him that said sum be paid immediately to the Oblige as liquidated damages, and not as a penalty, for the Principal's failure to perform.

The condition of this obligation is such that if the aforesaid Principal shall, within the period specified therefore, on the prescribed form presented to him for signature, enter into a written contract with the Oblige in accordance with his bid as accepted and give Performance and Payment Bond with good and sufficient surety or sureties, upon the form prescribed by the Oblige, for the faithful performance and the proper fulfillment of said Contract, or in the event of withdrawal of said bid within the time specified, or upon the payment to the Oblige of the sum determined upon herein, as liquidated damages and not as penalty, in the event the Principal fails to enter into said contract and give such Performance and Payment Bond within the time specified, then this Obligation shall be null and void, otherwise to remain in full force and effect.

Signed, sealed and delivered this 1st day of July, 20 22.

ATTEST

[Signature]
Vice Secretary, Ryan Mastrianni

Hamon Infrastructure, Inc.
Principal
By: [Signature]
Michael Walters, Vice President
Title: _____



Seal if Bidder is Corporation
(Attach Power-of-Army)

Great American Insurance Company
Surety
By: [Signature]
Ashlea McCaughey, Attorney-in-Fact
[SEAL]



GREAT AMERICAN INSURANCE COMPANY®

Administrative Office: 301 E 4TH STREET • CINCINNATI, OHIO 45202 • 513-369-5000 • FAX 513-723-2740

The number of persons authorized by
this power of attorney is not more than **SIX**

No. 0 21481

POWER OF ATTORNEY

KNOW ALL MEN BY THESE PRESENTS: That the GREAT AMERICAN INSURANCE COMPANY, a corporation organized and existing under and by virtue of the laws of the State of Ohio, does hereby nominate, constitute and appoint the person or persons named below, each individually if more than one is named, its true and lawful attorney-in-fact, for it and in its name, place and stead to execute on behalf of the said Company, as surety, any and all bonds, undertakings and contracts of suretyship, or other written obligations in the nature thereof; provided that the liability of the said Company on any such bond, undertaking or contract of suretyship executed under this authority shall not exceed the limit stated below.

| Name | Address | Limit of Power |
|-------------------|-------------------|----------------|
| DONALD E. APPLEBY | MARK SWEIGART | ALL |
| TODD D. BENG FORD | ASHLEA McCAUGHEY | \$100,000,000 |
| SARAH C. BROWN | JESSICA JEAN RINI | |

This Power of Attorney revokes all previous powers issued on behalf of the attorney(s)-in-fact named above.

IN WITNESS WHEREOF the GREAT AMERICAN INSURANCE COMPANY has caused these presents to be signed and attested by its appropriate officers and its corporate seal hereunto affixed this **28TH** day of **SEPTEMBER**, 2020



Attest
Steph C. Beraha
Assistant Secretary

GREAT AMERICAN INSURANCE COMPANY

Mark Vicario
Divisional Senior Vice President

STATE OF OHIO, COUNTY OF HAMILTON - ss:
On this **28TH** day of

SEPTEMBER

, 2020, before me personally appeared MARK VICARIO, to me known,

being duly sworn, deposes and says that he resides in Cincinnati, Ohio, that he is a Divisional Senior Vice President of the Bond Division of Great American Insurance Company, the Company described in and which executed the above instrument; that he knows the seal of the said Company; that the seal affixed to the said instrument is such corporate seal; that it was so affixed by authority of his office under the By-Laws of said Company, and that he signed his name thereto by like authority.

MARK VICARIO (877-377-2405)



SUSAN A KOHORST
Notary Public
State of Ohio
My Comm. Expires
May 18, 2025

Susan A Kohorst

This Power of Attorney is granted by authority of the following resolutions adopted by the Board of Directors of Great American Insurance Company by unanimous written consent dated June 9, 2008.

RESOLVED: That the Divisional President, the several Divisional Senior Vice Presidents, Divisional Vice Presidents and Divisional Assistant Vice Presidents, or any one of them, be and hereby is authorized, from time to time, to appoint one or more Attorneys-in-Fact to execute on behalf of the Company, as surety, any and all bonds, undertakings and contracts of suretyship, or other written obligations in the nature thereof; to prescribe their respective duties and the respective limits of their authority; and to revoke any such appointment at any time.

RESOLVED FURTHER: That the Company seal and the signature of any of the aforesaid officers and any Secretary or Assistant Secretary of the Company may be affixed by facsimile to any power of attorney or certificate of either given for the execution of any bond, undertaking, contract of suretyship, or other written obligation in the nature thereof, such signature and seal when so used being hereby adopted by the Company as the original signature of such officer and the original seal of the Company, to be valid and binding upon the Company with the same force and effect as though manually affixed.

CERTIFICATION

I, STEPHEN C. BERAHA, Assistant Secretary of Great American Insurance Company, do hereby certify that the foregoing Power of Attorney and the Resolutions of the Board of Directors of June 9, 2008 have not been revoked and are now in full force and effect.

Signed and sealed this **1st** day of **July**, 2022



Steph C. Beraha
Assistant Secretary

DIVERSITY AND INCLUSIVENESS IN CITY SOLICITATIONS INSTRUCTIONS

Include a copy of the completed form with your Bid Form Package in QuestCDN.

Click on the following link to complete and download the form to be uploaded into QuestCDN:

[Diversity and Inclusiveness* in City Solicitations Information Request Form \(openforms.com\)](https://openforms.com)

Denver Executive Order No. 101 establishes strategies between the City and private industry to use diversity and inclusiveness to promote economic development in the City and County of Denver and to encourage more businesses to compete for City contracts and procurements. The Executive Order requires, among other things, the collection of certain information regarding the practices of the City's contractors and consultants toward diversity and inclusiveness and encourages/requires City agencies to include diversity and inclusiveness policies in selection criteria where legally permitted in solicitations for City services or goods.

Diversity and Inclusiveness* in City Solicitations Information Request Form

Submission date: **13 July 2022, 10:03AM**

Receipt number: **412**

Related form version: **5**

Page 1/2

Business Email Address **rmastrrianni@hamoninfrastructure.com**

Enter Email Address of City and County of Denver
contact person facilitating this solicitation **doti.procurement@denvergov.org**

Please provide the City Agency that is facilitating this
solicitation: **Department of Transportation and Infrastructure
(DOTI)**

Project Name **Connecting Auraria**

Solicitation No. (If Applicable) **202263315**

Name of Your Company **Hamon Infrastructure, Inc.**

What Industry is Your Business? **Construction/Landscape/Maintenance Services**

Street Address **5670 Franklin St**

City **Denver**

State **CO**

ZIP Code **80216**

Business Phone Number **3032970340**

Business Facsimile Number **3032969601**

Page 2/2

1. How many employees does your company employ? **51 - 100**

1A. How many of your employees are full time? **75**

1B. How many of your employees are part time? **1**

2. Do you have a Diversity and Inclusiveness Program? **Yes**

2.1. Employment and retention? **Yes**

2.2. Procurement and supply chain activities? * **Yes**

2.3. Customer Service? **Yes**

3. Provide a detailed narrative of your company's diversity and inclusiveness principles and programs. This may include, for example, (i) diversity and inclusiveness employee training programs, equal opportunity policies, and the budget amount spent on an annual basis for workplace diversity; or (ii) diversity and inclusiveness training and information to improve customer service. (If Not Applicable, please type N/A below) *

Hamon Infrastructure, Inc. respects, values and celebrates the unique attributes, characteristics and perspectives that make each person who they are. We believe that our strength lies in our diversity among the broad range of people, subcontractors, suppliers, owners and communities we represent and with whom we work. We consider diversity and inclusion a driver of excellence and seek out diversity of participation, thought and action. It is our aim, therefore, that our members, partners, key stakeholders reflect and embrace these core values. Hamon's goal is to positively impact our company and local community by modeling excellence in diversity and inclusion in the following three areas:

Human Capital

It is important to support and nurture the employees of Hamon by creating positive workplace environments and structures that enable them to be engaged in their jobs and to challenge them appropriately to support growth.

Key Stakeholders

Individuals, organizations and corporations of all types have the potential to offer insight and expertise on a broad range of strategies related to diversity and

inclusion initiatives. We are committed to working collaboratively with key stakeholders locally and statewide to strengthen the integrity, impact and relevance of our diversity and inclusiveness program.

Programs and Resources

Hamon strives to leverage its programs and services to enhance the construction industry and its efforts to promote diversity and inclusion with an emphasis on:

Standards and Best Practices

Career Pipeline

Professional Development

Definitions

Diversity. The quality of being different or unique at the individual or group level. This includes age; ethnicity; gender; gender identity; language differences; nationality; parental status; physical, mental and developmental abilities; race; religion; sexual orientation; skin color; socio-economic status; education; work and behavioral styles; the perspectives of each individual shaped by their nation, experiences and culture—and more. Even when people appear the same on the outside, they are different.

Inclusion. The act of including; a strategy to leverage diversity. Diversity always exists in social systems. Inclusion, on the other hand, must be created. In order to leverage diversity, an environment must be created where people feel supported, listened to and able to do their personal best.

4. Does your company regularly communicate its diversity and inclusiveness policies to employees?

Yes

5. How often do you provide training and diversity and inclusiveness principles? **Annually**

5.1 What percentage of the total number of employees generally participate? **76 - 100%**

6. State how you achieve diversity and inclusiveness in supply and procurement activities. This may include, for example, narratives of training programs, equal opportunity policies, diversity or inclusiveness partnership programs, mentoring and outreach programs, and the amount and description of budget spent on an annual basis for procurement and supplier diversity and inclusiveness. (If Not Applicable, please type N/A below)

Hamon Infrastructure implements its diversity and inclusion policies in its supply and procurement activities. Hamon seeks out DBE subcontractors and suppliers using the unified DBE list produced by the City and County of Denver. In addition, Hamon seeks out minority-owned businesses to encourage them to apply for DBE certification. Hamon also mentors all DBE and minority-owned businesses as needed to assist and support them in successfully performing their work in accordance with project specifications.

7. Do you have a diversity and inclusiveness committee? **Yes**

8. Do you have a budget for diversity and inclusiveness efforts? **Yes**

9. Does your company integrate diversity and inclusion competencies into executive/manager performance evaluation plans? **Yes**

10. I attest that the information represented herein is true, correct and complete, to the best of my knowledge. **Check Here if the Above Statement is True.**

Name of Person Completing Form **Ryan Mastrianni**

Today's Date **07/13/2022**

NOTE: Attach additional sheets or documentation as necessary for a complete response.

CITY AND COUNTY OF DENVER
STATE OF COLORADO



DENVER
THE MILE HIGH CITY

**DEPARTMENT OF TRANSPORTATION &
INFRASTRUCTURE**

Bid Documents Package
Contract Number: 202263315

Connecting Auraria
June 6, 2022

**CITY AND COUNTY OF DENVER
DEPARTMENT OF TRANSPORTATION AND INFRASTRUCTURE**

TABLE OF CONTENTS FOR CONTRACT DOCUMENTS

| <u>BID FORM AND SUBMITTAL PACKAGE</u> | <u>PAGE</u> |
|--|--------------------|
| Package (returned separately and incorporated as part of these contract documents) | |
| BIDDER'S CHECKLIST | BF-2 |
| BID FORM AND SUBMITTAL PACKAGE ACKNOWLEDGMENT..... | BF-4 |
| BID FORM..... | BF-6 |
| 1A - LIST OF PROPOSED SUBCONTRACTORS, SUBCONSULTANTS, AND/OR SUPPLIERS | BF-9 |
| COMMITMENT TO MWBE PARTICIPATION | BF-13 |
| LETTER OF INTENT (LOI) | BF-14 |
| BID BOND..... | BF-15 |
| DIVERSITY AND INCLUSIVENESS IN CITY SOLICITATIONS INSTRUCTIONS | BF-16 |
| <u>BID DOCUMENTS</u> | |
| STATEMENT OF QUANTITIES | SQ-1 |
| NOTICE OF INVITATION FOR BIDS | BDP-2 |
| INSTRUCTIONS TO BIDDERS..... | BDP-4 |
| EQUAL EMPLOYMENT OPPORTUNITY RULES AND REGULATIONS..... | BDP-14 |
| APPENDIX A | BDP-18 |
| APPENDIX F | BDP-20 |
| CONTRACT | BDP-30 |
| GENERAL CONTRACT CONDITIONS (INDEX) | BDP-35 |
| SPECIAL CONTRACT CONDITIONS..... | BDP-40 |
| CONTRACTOR'S CERTIFICATION OF PAYMENT (SAMPLE)..... | BDP-45 |
| PERFORMANCE AND PAYMENT BOND | BDP-52 |
| PERFORMANCE AND PAYMENT BOND SURETY AUTHORIZATION (SAMPLE)..... | BDP-54 |
| NOTICE TO APPARENT LOW BIDDER (SAMPLE)..... | BDP-55 |
| NOTICE TO PROCEED (SAMPLE)..... | BDP-57 |
| CERTIFICATE OF CONTRACT RELEASE (SAMPLE)..... | BDP-58 |
| FINAL/PARTIAL RELEASE AND CERTIFICATE OF PAYMENT (SAMPLE)..... | BDP-59 |
| PREVAILING WAGE RATE SCHEDULE..... | 15 pages |
| TECHNICAL SPECIFICATIONS..... | 852 pages |
| CONTRACT DRAWINGS | 195 pages |

CITY AND COUNTY OF DENVER
NOTICE OF INVITATION FOR BIDS
FOR CONTRACT NO. 202263315

CONNECTING AURARIA

BID SCHEDULE:
11:00 a.m., Local Time
July 14, 2022

Bids will be received and accepted via the online electronic bid service, www.QuestCDN.com. Bids must be submitted via QuestCDN no later than **July 14, 2022 at 11:00 a.m.** To access the electronic bid form, download the required documents from QuestCDN and click the online bidding button at the top of the advertisement. Prospective bidders must be on the plan holders list at QuestCDN for bids to be accepted. Bidders will be charged a fee of \$30.00 to submit a bid electronically. All properly uploaded bids will then be opened, witnessed and read aloud.

Elevate Denver is a 10-year, \$937 million general obligation bond program approved by voters in 2017, that will enhance the City and County of Denver by providing critical improvements to the City's infrastructure – improving our roads, sidewalks, parks, recreation centers, libraries, cultural centers, public-owned buildings and safety facilities. More information can be found at www.denvergov.org/elevatedenver.

GENERAL STATEMENT OF WORK:

This project is the construction phase to remove and replace the Larimer Street bridge over Cherry Creek and Cherry Creek Trail and traffic signal upgrades at the intersections of Larimer Street and NB and SB Speer Blvd. Work will include demo of the existing bridge, earthwork, construction of a new bridge. In addition, the signal upgrades at the two intersections includes demo of the existing signal equipment, demo of the existing curb ramps, installation of upgraded signal equipment, construction of new curb ramps, and associated streetscape elements and landscaping. Traffic control and erosion control will be ongoing components of the project.

ESTIMATED CONSTRUCTION COST:

The estimated cost of construction for this project is between \$5,200,000.00 and \$5,700,000.00.

DOCUMENTS AND BID INFORMATION AVAILABLE:

Contract Documents complete with Technical Specifications and, if applicable, construction drawings will be available on the first day of publication at: www.work4denver.com. To download digital Contract Documents at a cost of \$15.00 per download, reference eBid Document Number #8216697. Contact QuestCDN at 952-233-1632 or info@questcdn.com for assistance.

PRE-BID MEETING:

A **virtual pre-bid meeting** will be held for this Project at **11:00 a.m.**, local time, on **June 14, 2022**. The teleconference call-in number and conference ID can be found on the project page at www.work4denver.com.

DEADLINE TO SUBMIT QUESTIONS: June 21, 2022 by 10:00 a.m. local time.

PREQUALIFICATION REQUIREMENTS:

Each bidder must be prequalified in category **IG(1) MAJOR BRIDGE WORK** at or above the **\$6,000,000.00** monetary level in accordance with the City's Rules and Regulations Governing Prequalification of Contractors. Each bidder must have submitted a prequalification application a minimum of ten (10) calendar days prior to the response

due date. Applications must be submitted via [B2Gnow](#). To view the Rules and information on how to apply, please visit our website at www.denvergov.org/prequalification.

MINORITY AND WOMEN-OWNED BUSINESS ENTERPRISE PARTICIPATION:

Article III, Division 3 of Chapter 28 of the D.R.M.C. states the Director of the Division of Small Business Opportunity has the authority to establish a project goal for expenditure contracted by the City and County of Denver. The specific goal for this project is:

19% Minority and Women-Owned Business Enterprise (MWBE) Participation

Project goals must be met with certified participants as set forth in Section 28-62, D.R.M.C. or through the demonstration of a sufficient good faith effort under Section 28-60 D.R.M.C.

MISCELLANEOUS:

Contracts for construction, reconstruction, and remodeling are subject to the City prevailing wage rate requirements established pursuant to Section 20-76, D.R.M.C.

City contracts are subject to payment of City Minimum Wage established pursuant to Section 20-82 through 20-84 D.R.M.C.

As its best interest may appear, the City and County of Denver reserves the right to reject any or all bids and to waive informalities in bids.

A modified version of this Notice of Invitation for Bids and the project's Statement of Quantities is available on the City and County of Denver's website at: www.work4denver.com.

Publication Dates: June 6, 7, 8, 2022
Published In: The Daily Journal

CITY AND COUNTY OF DENVER INSTRUCTIONS TO BIDDERS

IB-1 INSTRUCTION TO BIDDERS

These Instructions to Bidders are a part of the Contract Documents and are intended to serve as a guide to bidders. They are general in nature and may be amended or supplemented as needed to support any one specific invitation to bid. Each bidder shall prepare its bid in strict compliance with all requirements of the Contract Documents and by careful application of these instructions.

IB-2 BIDDING

The copy of the Contract Documents contains the Bid Form and Submittal Package for this Project, which must be used to submit a bid hereunder. The bidder must fully complete, execute and submit this Bid Form and Submittal Package, along with any other specified components of the Contract Documents, via QuestCDN's electronic bidding platform as its bid for the referenced Project.

A bidder is not required to submit as part of its bid the entire set of Contract Documents distributed by the City pursuant to the Notice of Invitation for Bids, if the bidder executes and submits the Bidder Acknowledgment Form included with the Bid Form and Submittal Package as part of its bid. However, each bidder, by submitting its bid, shall be conclusively presumed to have received and reviewed all of the information contained in the Contract Documents as this term is further defined herein.

Bid guarantee will be accepted electronically as part of the Bid packet submitted via QuestCDN. The bid guarantee must be received by the City within seven calendar days following the bid opening date to:

Department of Transportation and Infrastructure
Attention: Contract Administration
201 W. Colfax Ave. Dept. 614
Denver, CO 80202

IB-3 CONTRACT DOCUMENTS AS PUBLISHED BY CITY

Each bidder shall be responsible for, and shall be deemed to have received, all the information contained in the Contract Documents as distributed by the City pursuant to the Notice of Invitation for Bids, including addenda, whether or not such bidder has reviewed all or part of the Contract Documents in either its hard copy form or in any other format. If organizations or companies other than the City or its design professional distribute the City's Contract Documents for review by prospective bidders, whether in hard copy or via electronic or other media, neither the City nor its design professional shall be responsible for the content, completeness or accuracy of any information distributed or transmitted by any such organization or company.

IB-4 COMPLETING AND SIGNING THE BID FORMS

The bidder must complete the Bid Form by legibly writing or printing in ink, in words and figures as required, all the bidder's prices offered for the Work to be performed. All blank spaces, which require a response of the bidder, must be properly completed in full. If in the process of evaluating a bid, words and figures, as written on the Bid Form by the bidder, do not agree, the written words will govern.

For Bid Forms requiring unit price bids, the bidder shall enter in the Bid Worksheet spaces provided a unit price for each item for which a quantity is given.

Each bidder must sign the Bid Form and give the bidder's current business address. If an individual, the signature must be of the individual offering the bid; if a partnership, the signature must be that of a general partner; and if a corporation, both the president and the secretary must sign and the seal of the corporation

must be affixed to be visible via electronic format. Signatures of other persons may be acceptable if the bid contains sufficient evidence, satisfactory to the City in its sole discretion, to indicate that the other persons are authorized to bind the bidder.

IB-5 UNACCEPTABLE BIDS

The City will not accept bids from Bidders not prequalified with the City (if prequalification is required for this project), in arrears to the City upon debt or contract, or which are defaulters (as surety or otherwise) upon any obligation to the City.

IB-6 INFORMAL AND UNBALANCED BIDS

Any alteration, interlineations, erasure, omission, deletion or addition by the bidder to the Bid Form and Submittal Package or other parts of the Contract Documents submitted with the Bid Form and Submittal Package, as originally issued to the bidder, shall render the accompanying bid informal and may constitute cause for rejection.

Any unauthorized addition, conditional or alternate bids, failure to provide a unit price, lump sum amount or authorized alternate item specified or other irregularities of any kind which tend to render the bid incomplete, indefinite or ambiguous shall render the bid informal and may constitute cause for rejection.

Bids that are unbalanced so that each item does not reasonably carry its own proportion of cost or that contain inadequate or unreasonable prices for any item may be rejected. Bids, which have not acknowledged all addenda to the Contract Documents issued for this bid, may also be rejected.

The right is reserved by the City to reject any or all bids and to waive any informalities where it is deemed by the City to be in the best interests of the City to do so.

IB-7 ONLY ONE BID ACCEPTED

The City will accept only one bid for the same work from any one bidder. This includes bids that may be submitted under different names by one business enterprise.

IB-8 BID GUARANTEE

As a guarantee of good faith on the part of the bidder, each bid must be accompanied by a bid guarantee, consisting of either a certified or cashier's check made payable without condition to the order of the City and County of Denver or a bid bond written by an approved corporate surety in favor of the City and County of Denver. If the bid of a bidder is acceptable and the bidder is notified by the Manager that it is considered to be the Apparent Low Bidder and said bidder fails to execute a contract in the form prescribed or to furnish a performance and payment bond with a legally responsible and approved surety or to furnish the required evidence of insurance or satisfy all conditions precedent to contract execution within five (5) days after such notice is made by the City, said bid guarantee shall be forfeited to the City as liquidated damages and not as a penalty.

The bid guarantee shall be in the amount of five percent (5%) of the total bid unless otherwise specified in the Notice of Invitation for Bids and on the form appearing in the Contract Documents in the Bid Form and Submittal Package. Failure to submit a properly executed bid guarantee, on the form provided herein may, in the City's sole discretion, constitute cause for rejection.

Following award and execution of the Contract by the Apparent Low Bidder, or earlier in the sole discretion of the City, bid guarantees of all but the Apparent Low Bidder will be returned. When the Apparent Low Bidder executes the Contract and delivers to the City satisfactory performance and payment bonds, required insurance documentation, and has satisfied all conditions precedent to contract execution by the City, and after approval, if any, by the Council of the City of the proposed Contract with the Apparent Low Bidder,

the bid guarantee of the Apparent Low Bidder shall be returned. Such return shall be made within one hundred twenty (120) days from date bids are opened unless otherwise specified in the Special Contract Conditions.

IB-9 SITE INSPECTION AND INVESTIGATIONS

Prior to submitting a bid, the bidder is invited to inspect the work site and its surroundings. Although the bidder is not required to make such an inspection before bidding, for purposes of the Contract it shall be conclusively presumed that by failing to make such an inspection, the bidder has waived the right to later claim additional compensation or time extensions for conditions which would have been evident had the site been inspected.

Drawings and Technical Specifications, defining the Work to be done, were prepared on the basis of interpretation by the design professionals of information derived from investigations of the work site. Such information and data are subject to sampling errors, and the interpretation of the information and data depends to a degree on the judgment of the design professional. In view of this, the bidder is invited to make such additional investigations as the bidder's judgment dictates the need for such investigations. Information about the degree of difficulty of the Work to be done cannot totally be derived from either the Drawings or Technical Specifications or from the Manager or his representatives.

Since the bid information cannot be guaranteed, the Contractor shall have assumed the risks attendant to successful performance of the Work and shall never make claim for additional compensation or time extensions on the grounds that the nature or amount of work to be done was not understood by the bidder at the time of the bidding.

IB-10 INCONSISTENCIES

Any seeming inconsistencies or ambiguities between different provisions of the Contract Documents or any point which the bidder believes requires a decision or interpretation by the City must be inquired into by the bidder by addressing a formal written communication to the Manager of the Department of Transportation and Infrastructure and sending or delivering it to the office advertising this Project for bid at least forty-eight (48) hours, excluding Saturdays, Sundays, and holidays, before the time set for the opening of bids.

Information about the decision or interpretation made in response to any inquiry will be posted on www.work4denver.com. If the matter raised requires, in the sole discretion of the Manager, that an addendum to the bid documents be issued, such addendum will be published, and each bidder shall be required to acknowledge the addendum by signing and identifying it in the Bid Form when submitting the bid.

After bids are opened, all bidders must abide by the formal response of the Manager, as to any interpretation. The City shall not be bound, and the bidder shall not rely on any oral communication, interpretation clarification or determination of the Contract Documents prior to bid opening.

IB-11 WITHDRAWAL OF BID

A bidder may withdraw its bid at any time prior to the time for receipt of bids set forth in the Notice of Invitation for Bids by making written request upon the Manager of the Department of Transportation and Infrastructure. After such time, no bid may be withdrawn or modified.

Such request must be signed by the persons authorized to bind the bidder as defined in IB-4, **COMPLETING AND SIGNING THE BID FORMS**.

IB-12 WEBSITE

It shall be conclusively presumed that the bidder has, before submitting any bid, read and shall take full responsibility for all addenda, posted decisions, and other information relevant to the bid posted by the City on the www.QuestCDN.com website.

IB-13 PRE-BID MEETING

Bidders are urged to attend the pre-bid meeting(s) scheduled for this Project. Attendance is not mandatory; however, bidders will be held responsible for all information presented at such meeting(s).

IB-14 ADDENDA

As its best interests may require, the City may issue addenda to the Contract Documents. Such addenda shall be made available to all persons having purchased a set of Contract Documents as set forth in the Notice of Invitation for Bids contained herein. All bidders must acknowledge receipt of all addenda on the Bid Form at the time of submission of the bid.

IB-15 VIRTUAL BID OPENING

Unless otherwise suspended, delayed or canceled by posted notice from the Manager, bid opening will occur via teleconference at the time designated in the Notice of Invitation for Bid.

IB-16 EVALUATION OF BIDS AND BASIS OF BID SELECTION

Bids will be evaluated after being read out loud on the date and at the time designated in the legal advertisement. All bids will be reviewed for responsiveness to the requirements of the Contract Documents and whether or not the bids contain irregularities which could give any bidder an unfair advantage.

The Base Bid Total shall include the Textura Fee and any applicable allowances and/or force accounts. Alternates, if any are included in the bid, will be selected in the priority shown on the Bid Form, subject to the limits of available funds. Selection will be made on the basis of the lowest, total, responsive, qualified base bid plus the total of any alternates set forth on the Bid Form and selected by the City during evaluation. Bid selection will be subject to all requirements and special bidder qualifications contained herein and subject to approval of such resulting Contract in accordance with the Charter and Revised Municipal Code of the City and County of Denver. In addition to all other specified requirements, the City will correct arithmetical errors in all bids and corrected totals only will be considered as the basis of selection.

Upon concluding that the bid is, in fact, the lowest, total, responsive bid to the bidding conditions and that of a responsible, qualified bidder, the City will notify the Apparent Low Bidder.

As its best interests may appear, the City and County of Denver reserves the right to waive informalities in bids, to reject any and all bids and to rebid the Project.

IB-17 NOTICE TO APPARENT LOW BIDDER

The Notice to Apparent Low Bidder, a form of which is included in the Contract Special Conditions Section of the Contract Documents, is issued by the City directly to the selected bidder and informs the bidder that the Manager intends to seek approval of the execution of the Contract by the City in accordance with the Charter and Revised Municipal Code of the City and County of Denver. Specifically, it informs the bidder of its obligations with respect to execution of the Contract and instructs the bidder on how to proceed toward execution of the Contract. The City reserves the right to notify the Apparent Low Bidder, at any time within one hundred twenty (120) days from the date of the opening of the bids, that approval to contract with the Apparent Low Bidder shall be sought in accordance with the Charter and Revised Municipal Code of the City and County of Denver.

In accordance with the terms and conditions contained in the Bid Form and Submittal Package and any additional requirements set forth in the Notice to Apparent Low Bidder or elsewhere in the Contract Documents, the Apparent Low Bidder shall execute the Contract Form contained in the Contract Documents made available by the City for execution in the appropriate number of counterparts. The Apparent Low Bidder shall return the fully executed Contract Document sets, along with any supplemental documents required herein, to the City and shall comply with all other conditions, precedent to Contract execution within five (5) days of the date of issuance of the Notice to Apparent Low Bidder by the City. Failure to comply with each of these requirements within five (5) days of the date of issuance of the Notice to Apparent Low Bidder by the City shall render the bid nonresponsive and may constitute cause for rejection.

Issuance of such Notice shall not, however, constitute a commitment on the part of the City or create any rights in the Apparent Low Bidder to any contract with the City.

IB-18 EXECUTION OF CONTRACT

The process of executing a contract requires action by both the apparent low bidder and the City. After the City notifies the Apparent Low Bidder, the successful bidder shall provide certain supplemental documents for incorporation into the Contract Documents. These supplemental documents shall include: the properly executed Certificate of Insurance Forms evidencing the apparent low bidder's satisfactory compliance with the insurance requirements set forth in the Contract Documents; a properly executed Payment and Performance Bond Form and appropriate Power of Attorney evidencing the Apparent Low Bidder's satisfactory compliance with the bonding requirements set forth in the Contract Documents; and documentation of compliance with any other conditions precedent to execution of the Contract by the City set forth in the Contract Documents. The insurance and bond forms contained in the Contract Special Conditions Section of the Contract Documents must be used in satisfying these supplemental document requirements. The City will prepare the Contract Documents by incorporating all of the documents submitted by the Apparent Low Bidder into an executable contract, which the Apparent Low Bidder will sign electronically.

From here, all of the documents are forwarded to the City Attorney who will, if the insurance and bonding offered is acceptable and if all other elements of the Contract Documents are in order, recommend that the Manager and the Mayor approve the documents and, when required by the City Charter, prepare an ordinance for submittal to City Council authorizing the execution of the Contract. The City Attorney shall in all applicable instances submit the proposed contract and ordinance to City Council. After City Council approval, the Contract shall be reviewed by the City Attorney and routed for execution by the Mayor, the Clerk for attestation and the Auditor for countersignature and registration. When the total process of contract execution is complete, a Notice to Proceed will be issued and a single executed copy of the Contract will be delivered to the Contractor. Any work performed or a material purchased prior to the issuance of Notice to Proceed is at the Contractor's risk.

IB-19 BONDING REQUIREMENTS

In accordance with the provisions of General Contract Conditions, Title 15, PERFORMANCE AND PAYMENT BONDS, the minimum bonding requirements for this Contract are set forth in the form **CITY AND COUNTY OF DENVER PERFORMANCE AND PAYMENT BOND** contained in the Special Conditions Section of the Contract Documents. Upon receipt of Notice to Apparent Low Bidder, the apparent low bidder must cause this form bond to be purchased, executed and furnished, along with appropriate Powers of Attorney and a surety authorization letter (in form similar to the one attached), to the City in accordance with the instructions contained herein.

IB-20 INSURANCE REQUIREMENTS

The minimum insurance requirements for this Contract are set forth in the Special Conditions Section of the Contract Documents. Bidders are urged to consider, in preparing a bid hereunder, that each condition, requirement or specification set forth in the form certificate must be complied with by the Contractor and all subcontractors performing Work on the Project, unless such requirements are specifically accepted in writing by the City's Risk Management Office. The Contractor must either include all subcontractors performing work hereunder as insureds under each required policy or furnish a separate certificate for each subcontractor. In either case, the Contractor shall insure that each subcontractor complies with all of the coverage requirements.

IB-21 PERMITS AND LICENSES

All permits, licenses and approvals required in the prosecution of the work shall be obtained and paid for by the Contractor.

IB-22 [RESERVED]

IB-23 PAYMENT OF CITY MINIMUM WAGE

Contractor shall comply with, and agrees to be bound by, all requirements, conditions, and City determinations regarding the City's Minimum Wage Ordinance, Sections 20-82 through 20-84 D.R.M.C, including, but not limited to, the requirement that every covered worker shall be paid no less than the City Minimum Wage in accordance with the foregoing D.R.M.C. Sections.

Instances in which a worker is covered by both Prevailing Wage rate requirements and City Minimum Wage rate requirements, Contractor shall pay every covered worker the greater of the two.

The services being requested in this solicitation may involve services that are covered pursuant to Division 3.75 of Article IV of Chapter 20 of the Denver Revised Municipal Code ("D.R.M.C."), which is designed to address the issue of wage equity and cost of living affordability in the City & County of Denver. Contractor agrees that any contract with the City shall include a requirement that Contractor will comply with the provisions of D.R.M.C. §§20-82 through 20-84, including, but not limited to, paying all covered workers no less than the City Minimum Wage for all covered services rendered in connection with the Contract. Additionally, Contractor agrees that the contract shall require compliance with all current and future federal and state laws and City ordinances.

IB-24 TAX REQUIREMENTS

General. Bidders are referred to the General Contract Condition 323, TAXES, as to taxes to which they may be subject in performing the Work under this Contract, including but not limited to sales and use taxes and the Denver Occupational Privilege Tax. The following instructions are to be considered along with the General Contract Conditions and not in lieu of them.

Sales and Use Tax. The City of Denver imposes consumer use tax on all construction and building materials used on any construction project located in Denver. Denver does not exempt governmental or charitable projects.

It is the responsibility of the Contractor and its subcontractors to apply to the Colorado Department of Revenue ("CDOR") for a certificate, or certificates, of exemption indicating that their purchase of construction or building materials is for a public project, and to deliver to the City copies of such applications as soon as possible after approval by the CDOR. Bidders shall include Denver sales/use tax, Occupational Privilege taxes, and shall not include in their bid amounts the exempt state, RTD, and Cultural Facilities District Sales and Use Taxes.

Denver Occupational Privilege Tax. Any employee working for a contractor, or a subcontractor, who earns \$500 or more working in Denver during a calendar month, is subject to the payment of the Employee Occupational Privilege Tax. The Contractor and any subcontractor must pay the Business Occupational Privilege Tax for each of its employees who are subject to such tax.

IB-25 DIVERSITY AND INCLUSIVENESS IN CITY SOLICITATIONS

Effective January 4, 2016, the method in which City collects Diversity and Inclusiveness data has changed from a physical form to a link where all prospective bidders must enter required information. Each bidder shall, **as a condition of responsiveness to this solicitation**, complete and submit via the link below, their response to the “Diversity and Inclusiveness in City Solicitations Information Request Form”. Include a copy of the completed form with your Bid Form Package in QuestCDN. [Diversity and Inclusiveness* in City Solicitations Information Request Form \(openforms.com\)](#).

The information provided on the “Diversity and Inclusiveness in City Solicitations Information Request Form” will provide an opportunity for City contractors to describe their own diversity and inclusiveness practices. Contractors are not expected to conduct intrusive examinations of its employees, managers, or business partners in order to describe diversity and inclusiveness measures. Rather, the City simply seeks a description of the contractor’s current practices, if any.

Diversity and Inclusiveness information provided by City contractors in response to City solicitations for services or goods will be collated, analyzed, and made available in reports consistent with City Executive Order No. 101. However, no personally identifiable information provided by or obtained from contractors/consultants will be in such reports.

Executive Order 101 is available for review at www.denvergov.org/content/denvergov/en/executive-orders.html.

IB-26 MINORITY AND WOMEN-OWNED BUSINESS ENTERPRISE (MWBE) REQUIREMENTS

Article III, Divisions 1 and 3 of Chapter 28, Denver Revised Municipal Code (D.R.M.C.), referred to in these Bid Documents as the “MWBE Ordinance” and any Rules or Regulations promulgated pursuant thereto apply to this Project and are incorporated into these Bid Documents by reference. Under the MWBE Ordinance, the Director of DSBO (“Director”) has the authority to establish participation goals on contracts for construction, reconstruction, remodeling, professional and design work with the City and County of Denver. The participation goal is stated in the Notice of Invitation for Bids found herein. In order to comply with the bid requirements of the MWBE Ordinance, or any additional requirements, a bidder shall either meet the established participation goal or, in the alternative, demonstrate that the bidder has demonstrated sufficient good faith efforts to meet the goal in accordance with the MWBE Ordinance. A bidder’s failure to comply with the MWBE Ordinance, any Rules or Regulations promulgated pursuant thereto, or any additional requirement contained herein shall render the bid non-responsive and shall constitute cause for rejection. Failure by the contractor awarded the contract to comply with MWBE Ordinance requirements during the performance of the contract is a material breach of the contract, which may result in the imposition of sanctions on the Contractor, as deemed appropriate by DSBO. Copies of the MWBE Ordinance and its accompanying Rules and Regulations are available for the use and review of bidders from DSBO. As well as additional MWBE Guidance which can be found here: <https://www.denvergov.org/dsbo>.

Meeting Established Goal

1. All MWBEs listed for participation toward meeting the goal must be properly certified by the City on or before the date bids are opened. The MWBE(s) must be certified in the NAICS code(s) that coincide with the scope of work the identified firm will be performing to count towards the participation goal.

DSBO maintains an MWBE Directory (“Directory”), which is a current list of MWBEs certified by the City. A copy of the Directory is located at the DSBO web site at <https://www.denvergov.org/dsbo>. Bidders are encouraged to use the Directory to assist in identifying MWBEs for the work and supplies required for the Project. Bidders are reminded that changes may be made to the Directory at any time in accordance with the City's MWBE Ordinance. Procedures established to administer this program and a current copy of the Directory must always be used in preparing a bid. MWBE certification or listing in the Directory is not a representation or warranty by the City regarding the qualifications of any listed MWBE.

2. If a bidder is participating in a joint venture with a certified MWBE firm, bidders must submit the Joint Venture Agreement to the DSBO **at least ten (10) business days prior to the bid opening**. The Joint Venture must be approved prior to the bid opening by the DSBO. Approval by the DSBO includes determining the amount the Joint Venture will count towards the participation goal.
3. Each bidder shall submit Bid Form pages entitled Commitment to MWBE Participation, 1A- List of Proposed Subcontractors, Subconsultants, and/or Suppliers, and Letter(s) of Intent for all tiers with the bid at the time of bid opening. DSBO will evaluate each bid to determine responsiveness of the bid with regard to MWBE Ordinance requirements. **An MWBE Prime Bidder must submit a Letter of Intent for itself for self-performed work.** The MWBE Letter of Intent evidences the Bidder’s understanding that the Bidder has or will enter into a contractual relationship with the MWBE or that the Bidder’s subcontractor(s), subconsultant(s), and/or supplier(s) will do so. Bidders are urged to carefully review these Letters of Intent before submission to the City to ensure the documents are properly completed and executed by the appropriate parties. **Only the MWBEs identified and the precise levels of participation listed for each, at the time of bid opening, will be considered in determining whether the bidder has met the designated participation goal. Additional, participation submitted after bid opening will not be considered in determining responsiveness.**
 - a. In determining whether a bidder’s committed level of participation meets the stated MWBE goal, DSBO shall base its calculation of applicable dollar amounts and percentages on the total base bid amount. If a bid contains alternates, participation contained in any alternate will not count towards satisfaction of the Participation goal at time of bid opening. However, should any designated alternate be selected by the City for inclusion in the contract ultimately awarded, the MWBE goal percentage level submitted at time of bid opening, on the base bid, will also apply to the selected alternates and must be maintained through the remaining term of the contract on the total contract amount, including any alternate work. Therefore, bidders are urged to consider participation in preparing bids for designated alternates.
 - b. In utilizing the MWBE participation of a Supplier the following will count towards satisfaction of the goal:
 - i. If the materials or supplies are obtained from a MWBE manufacturer, count one hundred percent (100%) of the cost of the materials or supplies toward the participation goal.
 - ii. Only sixty percent (60%) of the value of the commercially useful function performed by MWBE Regular Dealers shall count toward satisfaction of the participation goal.
 - iii. Only the bona fide commissions earned by such Manufacturer Representatives or Brokers for its performance of a commercially useful function will count toward meeting the participation goals. The bidder must separate the bona fide brokerage

commissions from the actual cost of the supplies or materials provided to determine the actual dollar amount of participation that can be counted towards meeting the goal.

- c. Any agreement between a bidder and an MWBE in which the bidder requires that the MWBE not provide subcontracting quotations to other bidders is prohibited and shall render a bidder's bid nonresponsive. D.R.M.C. 28-68(f)

Good Faith Effort

If the bidder has not fully met the participation goal as provided in D.R.M.C. Section 28-62, then it shall demonstrate that it has made good faith efforts to meet such goal. The bidder shall furnish to the Director, with the bid at time of bid opening by the City a detailed statement of its good faith efforts to meet the participation goal established by the Director. The statement of good faith efforts shall include a specific response to address each of the categories, as outlined in the MWBE Ordinance, D.R.M.C. Section 28-62, and any additional criteria that the Director may establish by rule or regulation consistent with the purposes of the MWBE Ordinance. A bidder may include any additional information it believes may be relevant. Good faith efforts must be demonstrated to be substantive and not merely for formalistic compliance with the MWBE Ordinance. The scope and adequacy of the efforts will be considered in determining whether the bidder has achieved a good faith effort. Failure of a bidder to show good faith efforts shall render its overall good faith effort showing insufficient and its bid nonresponsive.

IB-27 DISCLOSURE OF INFORMATION

All submissions and other materials provided or produced pursuant to this Invitation for Bids may be subject to the Colorado Open Records Law, C.R.S. 24-72-201, et seq. As such, bidders are urged to review these disclosure requirements and any exceptions to disclosure of information furnished by another party and, prior to submission of a bid to the City, appropriately identify materials that are not subject to disclosure. In the event of a request to the City for disclosure of such information, the City shall advise the bidder of such request to give the bidder an opportunity to object to the disclosure of designated confidential materials furnished to the City. In the event of the filing of a lawsuit to compel such disclosure, the City will tender all such material to the court for judicial determination of the issue of disclosure and each bidder agrees to intervene in such lawsuit to protect and assert its claims of privilege against disclosure of such material. Each bidder further agrees to defend, indemnify and save and hold harmless the City, its officers, agents and employees, from any claim, damages, expense, loss or costs arising out of the bidder's intervention to protect and assert its claims of privilege against disclosure under the Open Records Law including, but not limited to, prompt reimbursement to the City of all reasonable attorney fees, costs and damages that the City may incur directly or may be ordered to pay by such court.

IB-28 GENERAL BIDDING INFORMATION

Bidders are instructed to contact the Contract Administrator designated below for this Project for pre-bid, post-bid and general City bidding information. Bidders can also visit www.work4denver.com for information, both general and project specific. The Contract Administrator assigned to this project is **Regina Diaz** who can be reached via email at doti.procurement@denvergov.org.

[REMAINDER OF PAGE INTENTIONALLY LEFT BLANK]

IB-29 PAYMENT PROCEDURE REQUIREMENTS**Textura® Construction Payment Management System (“Textura”)**

Bidder recognizes and agrees that it shall be required to use the Textura® Construction Payment Management System (“Textura”) for this Project to request payment from the City and to pay all first tier subcontractors and suppliers and further record payment to all certified subcontractors or suppliers that are listed for participation towards any assigned program goal. All fees associated with Textura are to be paid by the bidder for billings for work performed. Bidders are required, when preparing a bid, to enter the price of Textura on the line provided for the service on the Bid Worksheet. The fee is all inclusive of all subcontractor, project and subscription fees associated with Textura. The bidder will calculate the fee based on their Base Bid Total (including Force Accounts and Allowances but not including any alternates, if applicable) and the table below, and then include it on the line item provided in the bid form labeled “Textura® Fee”. This expense becomes part of the contract and billable to the City. All costs including, but not limited to, costs associated with training, entering data, and/or utilizing Textura other than the Textura Construction Payment Management System Fee are overhead and shall not be reimbursed by the City. Bidder will be responsible for any tax on the Textura fee. As with other taxes, the City will not reimburse bidder for this cost and therefore this cost should be included in bidder’s bid. Textura will invoice the awarded bidder directly.

| Project Value | Project Fee (GC + Sub Usage) |
|--------------------------------|---------------------------------|
| \$100,000 – 249,999.99 | \$780 |
| \$250,000 - \$499,999.99 | \$1,625 |
| \$500,000 - \$999,999.99 | \$3,250 |
| \$1,000,000 - \$2,999,999.99 | \$5,850 |
| \$3,000,000 - \$4,999,999.99 | \$9,100 |
| \$5,000,000 - \$9,999,999.99 | \$12,220 |
| \$10,000,000 - \$19,999,999.99 | \$20,345 |
| \$20,000,000 - \$49,999,999.99 | \$32,500 |

[REMAINDER OF PAGE INTENTIONALLY LEFT BLANK]

RULES AND REGULATIONS REGARDING EQUAL EMPLOYMENT OPPORTUNITY

Promulgated and adopted by the Manager of Public Works pursuant to and by authority of Article III, Division 2, Chapter 28 of the Revised Municipal Code of the City and County of Denver, and for the purpose of insuring that contractors, subcontractors and suppliers soliciting and receiving compensation for contract work from or through the City and County of Denver provide equal opportunity in employment without regard to race, color, creed, sex, national origin, age, religion, marital status, political opinion or affiliation or mental or physical handicap and meet certain requirements for the hiring, training, promotion and treatment during employment of members of ethnic groups subjected to differential treatment, including persons of African descent (Black), Spanish-surnamed (Hispanic), Asian-American and American Indian groups.

RULE I DEFINITIONS

- A. "City" means the City and County of Denver.
- B. "Manager" shall mean the Manager of Public Works for the City and County of Denver.
- C. "Contract" means a contract entered into with the City and County of Denver, financed in whole or in part by local resources or funds of the City and County of Denver, for the construction of any public building or prosecution or completion of any public work.
- D. "Contractor" means the original party to a contract with the City and County of Denver, also referred to as the "general" or "prime" contractor.
- E. "Director" means the Director of the Mayor's Office of Contract Compliance.
- F. "Subcontractor" means any person company, association, partnership, corporation, or other entity which assumes by subordinate agreement some or all of the obligations of the general or prime contractor.
- G. The Phrase "Bidding Specifications" as used in Article III, Division 2 of Chapter 28 of the Revised Municipal Code shall include **BID CONDITION, INVITATION TO BID AND NOTICE OF PROPOSAL.**
- H. "Affirmative Action Program" means a set of specific and result-oriented procedures or steps to which a contractor commits himself to apply every good faith effort to employ members of ethnic minority groups, to include persons of African descent (Black), Spanish surnamed (Hispanic), Asian-American, American Indians, and persons with mental or physical handicap.
- I. "Mayor's Office of Contract Compliance" means the City agency established pursuant to Article III, Division 1 of Chapter 28 of the Denver Revised Municipal Code.

Revised: 10/19/93

EEO-2

RULE II
NOTICE OF HEARING

When results of conciliation efforts are unsatisfactory to the Manager and he is informed in accordance with Article III, Division 2 of Chapter 28 of the Revised Municipal Code that a contractor or subcontractor has apparently failed to meet affirmative action and equal employment opportunity requirements after a reasonable period of notice to correct deficiencies, the Manager will, prior to imposition of any sanctions, afford the general contractor a hearing in order to determine whether the contractor or his subcontractors have failed to comply with the affirmative action and equal employment opportunity requirements of Article III, Division 2 of Chapter 28 of the Revised Municipal Code or of the contract. Written notice of such hearing shall be delivered personally or sent by certified mail return receipt requested, to the contractor and to any subcontractor involved at least ten days prior to the date scheduled for the hearing.

RULE III
HEARING

- A. Contractors will appear at hearings and may be represented by counsel and may present testimony orally and other evidence.
- B. Hearings shall be conducted by one or more hearing examiners designated as such by the Manager.
- C. The Director of the Mayor's Office of Contract Compliance may participate in hearings as a witness.
- D. Hearings shall be held at the place specified in the notice of hearing.
- E. All oral testimony shall be given under oath or affirmation and a record of such proceedings shall be made.
- F. All hearings shall be open to the public.
- G. The hearing officer shall make recommendations to the Manager who shall make a final decision.

REGULATIONS

REGULATION NO. 1. **ORDINANCE:** The Rules and Regulations of the Manager shall be inserted in the bidding specifications for every contract for which bidding is required.

REGULATION NO. 2. **EXEMPTIONS:** Each contract and subcontract, regardless of dollar amount, shall be subject to affirmative action requirements unless specifically exempted in writing individually by the Manager. Exemptions apply only to "affirmative action" in equal employment opportunity, and are not to be construed as condonation in any manner of "discrimination" or "discriminatory practices" in employment because of race, color, creed, sex, age, national origin, religion, marital status, political opinion or mental or physical handicap.

Revised: 10/19/93

EEO-3

REGULATION NO. 3. DIRECTOR OF CONTRACT COMPLIANCE: The Director of the Mayor's Office of Contract Compliance shall perform the duties assigned to such official by Article III, Division 2 of Chapter 28 of the Revised Municipal Code and by the Manager. (1) The Director of the Mayor's Office of Contract Compliance or designated representatives shall inform bidders and contractors of affirmative action procedures, programs, and goals in accordance with the ordinance at pre-bid and pre-construction conference; (2) make regular on-site inspections; (3) supply contractors and subcontractors with report forms to be completed by them when requested, and furnished to the Director of the Mayor's Office of Contract Compliance; and (4) review payroll records, employment records and practices of general contractors and their subcontractors and suppliers during the performance of any contract. The Director of the Mayor's Office of Contract Compliance shall promptly report apparent affirmative action deficiencies to the Manager.

REGULATION NO. 4. GOALS AND TIMETABLES: In general, goals and timetables should take into account anticipated vacancies and the availability of skills in the market place from which employees should be drawn. In addition, where discrimination in employment by a general contractor or any of his subcontractors is indicated, a corrective action program will take into account the need by the general contractor and his subcontractors to correct past discriminatory practices and reach goals of minority manpower utilization on a timely basis through such recruiting and advertising efforts as are necessary and appropriate.

REGULATION NO. 5. AWARD OF CONTRACTS: It shall be the responsibility of the Director of the Mayor's Office of Contract Compliance to determine the affirmative action capability of bidders, contractors and subcontractors and to recommend to the Manager the award of contracts to those bidders, contractors and subcontractors and suppliers who demonstrate the ability and willingness to comply with the terms of their contract.

REGULATION NO. 6. PUBLICATION AND DUPLICATION: Copies of these Rules and Regulations as amended by the Manager from time to time, shall as soon as practicable and after Notice being published will be made a part of all City Contracts.

REGULATION NO. 7. NOTICE TO PROCEED: Prior to issuance of Notice to Proceed a sign-off will be required of the Director of the Mayor's Office of Contract Compliance or his designee.

REGULATION NO. 8. CONTRACTS WITH SUBCONTRACTORS: To the greatest extent possible the contractor shall make a good faith effort to contract with minority contractors, subcontractors and suppliers for services and supplies by taking affirmative actions which include but are not limited to the following:

1. Advertise invitations for subcontractor bids in minority community news media.
2. Contact minority contractor organizations for referral of prospective subcontractors.
3. Purchase materials and supplies from minority material suppliers.

Revised: 10/19/93

EEO-4

REGULATION NO. 9. AGENCY REFERRALS: it shall be no excuse that the union with which the contractor or subcontractor has an agreement providing for referral, exclusive or otherwise, failed to refer minority employees.

REGULATION NO. 10. CLAUSES: The Manager shall include the appropriate clauses in every contract and the contractor shall cause to be inserted in every subcontract the appropriate clauses:

1. **APPENDIX A:** City and County of Denver Equal Opportunity Clause-ALL CONTRACTS funded only with City & County of Denver monies.
2. **APPENDIX B:** Equal Opportunity Clause (11246)-ALL FEDERAL ASSISTED
3. **APPENDIX C:** Section 3-Assurance of Compliance-HUD ASSISTED PROJECTS.
4. **APPENDIX D:** Section 3-Clause-HUD ASSISTED PROJECTS.

All amendments to the appendices shall be included by reference.

REGULATION NO. 11. SHOW CAUSE NOTICES: When the Manager has reasonable cause to believe that a contractor has violated Article III, Division 2 of Chapter 28 of the Revised Municipal Code, he may issue a notice requiring the contractor to show cause, within fifteen days why enforcement procedures, or other appropriate action to insure compliance, should not be instituted.

REGULATION NO. 12. BID CONDITIONS-AFFIRMATIVE ACTION REQUIREMENTS-EQUAL EMPLOYMENT OPPORTUNITY:

1. **APPENDIX E:**

The Bid Conditions-Affirmative Action Requirements-Equal Employment Opportunity as amended and published by the U.S. Department of Labor, Employment Standards Administration, Office of Federal Contract Compliance, shall be inserted verbatim for bidding specification for every non-exempt contract involving the use of Federal funds.

2. **APPENDIX F:**

The Bid Conditions-Affirmative Action Requirements-Equal Employment Opportunity as published by the Department of Public Works, City and County of Denver shall be inserted verbatim as bidding specifications for every non-exempt contract using City funds.

Revised: 04/12/91

EEO-5

APPENDIX A

CITY AND COUNTY OF DENVER EQUAL OPPORTUNITY CLAUSE-ALL CONTRACTS

1. The contractor will not discriminate against any employee or applicant for employment because of race, creed, color, sex, age, national origin, religion, marital status, political opinion or affiliation, or mental or physical handicap. The contractor will take affirmative action to ensure that applicants are employed, and that employees are treated during employment without regard to their race, creed, color, sex, age, national origin, religion, marital status, political opinion or affiliation, or mental or physical handicap. Such action shall include, but not be limited to the following: employment, upgrading, demotion, or transfer; recruitment or recruitment advertising; layoff or termination; rates of pay or other forms of compensation; and selection for training, including apprenticeship. The contractor agrees to post in conspicuous places, available to employees and applicants for employment, notices to be provided setting forth the provisions of this nondiscrimination clause.
2. The contractor will, in all solicitations or advertisements for employees placed by or on behalf of the contractor, state that all qualified applicants will receive consideration for employment without regard to race, creed, color, sex, age, national origin, religion, marital status, political opinion or affiliation, or mental or physical handicap.
3. The contractor will send to each labor union or representative of workers with which he has a collective bargaining agreement or other contract or understanding, a notice to be provided, advising the said labor union or workers' representatives of the contractor's commitments under this section, and shall post copies of the notice in conspicuous places available to employees and applicants for employment.
4. Each contractor will comply with all provisions of Article III, Division 2, Chapter 28 of the Revised Municipal Code, and the rules, regulations, and relevant orders of the Manager and Director.
5. The contractor will furnish all information and reports required by Article III, Division 2, Chapter 28 of the Revised Municipal Code, and by rules, regulations and orders of the Manager and Director or pursuant thereto, and will permit access to his books, records, and accounts by the Manager, Director or their designee for purposes of investigation to ascertain compliance with such rules, regulations, and orders.
6. In the event of the contractor's noncompliance with the nondiscrimination clauses of this contract or with any of the said rules, regulations or orders this contract may be cancelled, terminated, or suspended in whole or in part and the contractor may be declared ineligible for further City contracts in accordance with procedures authorized in Article III, Division 2, Chapter 28 of the Revised Municipal Code, or by rules, regulations, or order of the Manager.

Revised: 09/28/90

EEO-A1

7. The contractor will include Regulation 12 Paragraph 2 and the provisions of paragraphs (1) through (6) in every subcontract or purchase order unless, exempted by rules, regulations, or orders of the Manager issued pursuant to Article III, Division 2, Chapter 28 of the Revised Municipal Code, so that such provisions will be binding upon each subcontractor or suppliers. The contractor will take such action with respect to any subcontract or purchase order as the administering agency may direct as a means of enforcing such provisions, including sanctions for noncompliance.

The applicant further agrees to be bound by the above equal opportunity clauses with respect to its own employment practices when it participates in City contracts. The contractor agrees to assist and cooperate actively with the Manager and the Director in obtaining compliance of subcontractors and suppliers with the equal opportunity clause and the rules, regulations and relevant orders of the Manager, and will furnish the Manager and the Director such information as they may require for the supervision of compliance, and will otherwise assist the Manager and Director in the discharge of the City's primary responsibility for securing compliance. The contractor further agrees to refrain from entering into any contract or contract modification subject to Article III, Division 2, Chapter 28 of the Revised Municipal Code with a contractor debarred from, or who has not demonstrated eligibility for, City contracts.

The contractor will carry out such sanctions and penalties for violation of the equal opportunity clause as may be imposed upon contractors and subcontractors by the Manager and Director. In addition, the contractor agrees that failure or refusal to comply with these undertakings the Manager may take any or all of the following actions:

- (A) Cancellation, termination, or suspension in whole or in part of this contract.
- (B) Refrain from extending any further assistance to the applicant under the program with respect to which the failure occurred until satisfactory assurance of future compliance has been received from such applicant.
- (C) Refer the case to the City Attorney for appropriate legal proceedings.

SUBCONTRACTS: Each prime contractor or subcontractor shall include the equal opportunity clause in each of its subcontracts.

Revised: 10/02/90

EEO-A2

APPENDIX F
BID CONDITIONS
AFFIRMATIVE ACTION REQUIREMENTS
EQUAL EMPLOYMENT OPPORTUNITY

For all Non-Exempt Construction Contracts to be Awarded by
the City and County of Denver, Department of Public Works

NOTICE

EACH BIDDER, CONTRACTOR OR SUBCONTRACTOR (HEREINAFTER THE CONTRACTOR) MUST FULLY COMPLY WITH THE REQUIREMENTS OF THESE BID CONDITIONS AS TO EACH CONSTRUCTION TRADE IT INTENDS TO USE ON THIS CONSTRUCTION CONTRACT, AND ALL OTHER CONSTRUCTION WORK (BOTH CITY AND NON-CITY) IN THE DENVER AREA DURING THE PERFORMANCE OF THIS CONTRACT OR SUBCONTRACT. THE CONTRACTOR COMMITS ITSELF TO THE GOALS FOR MINORITY MANPOWER UTILIZATION, AS APPLICABLE, AND ALL OTHER REQUIREMENTS, TERMS AND CONDITION OF THESE BID CONDITIONS BY SUBMITTING A PROPERLY SIGNED BID.

THE CONTRACTOR SHALL APPOINT A COMPANY EXECUTIVE TO ASSUME THE RESPONSIBILITY FOR THE IMPLEMENTATION OF THE REQUIREMENTS, TERMS AND CONDITIONS OF THESE BID CONDITIONS.

MICHAEL D. MUSGRAVE
Manager of Public Works
City and County of Denver

Revised: 10/19/93

EEO-F1

A. **REQUIREMENTS --AN AFFIRMATIVE ACTION PLAN:**

Contractors shall be subject to the provisions and requirements of these bid conditions including the goals and timetables for minority' and female utilization, and specific affirmative action steps set forth by the Office of Contract Compliance. The contractor's commitment to the goals for minority, and female utilization as required constitutes a commitment that it will make every good faith effort to meet such goals.

1. **GOALS AND TIMETABLES:**

The goals and timetables for minority and female participation, expressed in percentage terms for the contractor's aggregate workforce in each trade are as follows:

| | |
|---|--|
| <p>GOALS FOR MINORITY PARTICIPATION FOR EACH TRADE From January 1, 1982 to 21.7% - 23.5% Until Further Notice</p> | <p>GOALS FOR FEMALE PARTICIPATION FOR EACH TRADE From January 1, 1982 to 6.9% Until Further Notice</p> |
|---|--|

The goals for minority and female utilization above are expressed in terms of hours of training and employment as a proportion of the total number of hours to be worked by the contractor's aggregate workforce, which includes all supervisory personnel, in each trade, on all projects for the City and County of Denver during the performance of its contract (i.e., The period beginning with the first day of work on the City and County of Denver funded construction contract and ending with the last day of work).

¹"Minority" is defined as including, Blacks, Spanish Surname Americans, Asian-Americans, and American Indians, and includes both men and Minority women.

Revised: 10/02/90

EEO-F2

The hours of minority and female employment and training must be substantially uniform throughout the length of the contract in each trade and minorities and females must be employed evenly on each of a contractor's projects. Therefore, the transfer of minority or female employees from contractor to contractor or from project to project for the purpose of meeting the contractor's goals shall be a violation of these Bid Conditions.

If the contractor counts the nonworking hours of apprentices they must be employed by the contractor during the training period; the contractor must have made a commitment to employ apprentices at the completion of their training subject to the availability of employment opportunities; and the apprentices must be trained pursuant to training programs approved by the Bureau of Apprenticeship and Training.

2. **SPECIFIC AFFIRMATIVE ACTION STEPS:**

No contractor shall be found to be in noncompliance solely on account of its failure to meet its goals, but will be given an opportunity to demonstrate that the contractor has instituted all the specific affirmative action steps specified and has made every good faith effort to make these steps work toward the attainment of its goals within the timetables, all to the purpose of expanding minority and female utilization in its aggregate workforce. A contractor, who fails to comply with its obligation under the Equal Opportunity Clause of its contract and fails to achieve its commitments to the goals for minority and female utilization has the burden of proving that it has engaged in an Affirmative Action Program directed at increasing minority and female utilization and that such efforts were at least as extensive and as specific as the following:

Revised: 11/12/82

EEO-F3

- a. The contractor should have notified minority and female organizations when employment opportunities were available and should have maintained records of the organization's response.

- b. The contractor should have maintained a file of the names and addresses of each minority and female referred to it by any individual or organization and what action was taken with respect to each such referred individual, and if the individual was not employed by the contractor, the reasons. If such individual was sent to the union hiring hall for referral and not referred back by the union or if referred, not employed by the contractor, the file should have documented this and their reasons.

- c. The contractor should have promptly notified the Department of Public Works, and Mayor's Office of Contract Compliance when the union or unions with which the contractor has collective bargaining agreements did not refer to the contractor a minority or female sent by the contractor, or when the contractor has other information that the union referral process has impeded efforts to meet its goals.

- d. The contractor should have disseminated its EEO policy within its organization by including it in any employee handbook or policy manual; by publicizing it in company newspapers and annual reports and by advertising such policy at reasonable intervals in union publications. The EEO policy should be further disseminated by conducting staff meetings to explain and discuss the policy; by posting of the policy; and by review of the policy with minority and female employees.

Revised: 10/19/93

EEO-F4

The contractor should have disseminated its EEO policy externally by informing and discussing it with all recruitment sources; by advertising in news media, specifically including minority and female news media; and by notifying and discussing it with all subcontractors.

- e. The contractor should have made both specific and reasonably recurrent written and oral recruitment efforts. Such efforts should have been directed at minority and female organizations, schools with substantial minority and female enrollment, and minority and female recruitment and training organizations within the contractor's recruitment area.
- f. The contractor should have evidence available for inspection that all tests and other selection techniques used to select from among candidates for hire, transfer, promotion, training, or retention are being used in a manner that does not violate the OFCCP Testing Guidelines in 41 CFR Part 60-3.
- g. The contractor should have made sure that seniority practices and job classifications do not have a discriminatory effect.
- h. The contractor should have made certain that all facilities are not segregated by race.
- i. The contractor should have continually monitored all personnel activities to ensure that its EEO policy was being carried out including the evaluation of minority and female employees for promotional

Revised: 10/19/93

EEO-F5

opportunities on a quarterly basis and the encouragement of such employees to seek those opportunities.

k. The contractor should have solicited bids for subcontracts from available minority and female subcontractors engaged in the trades covered by these Bid conditions, including circulation of minority and female contractor associations.

NOTE: The Director and the Mayor's Office of Contract Compliance will provide technical assistance on questions pertaining to minority and female recruitment sources, minority and female community organizations, and minority and female news media upon receipt of a request for assistance from a contractor.

3. **NON-DISCRIMINATION:** In no event may a contractor utilize the goals and affirmative action steps required in such a manner as to cause or result in discrimination against any person on account of race, color, religion, sex, marital status, national origin, age, mental or physical handicap, political opinion or affiliation.

4. **COMPLIANCE AND ENFORCEMENT:** In all cases, the compliance of a contractor will be determined in accordance with its obligations under the terms of these Bid Conditions. All contractors performing or to perform work on projects subject to these Bid Conditions hereby agree to inform their subcontractors in writing of their respective obligations under the terms and requirements of these Bid Conditions, including the provisions relating to goals of minority and female employment and training.

Revised: 10/19/93

EEO-F6

A. **Contractors Subject to these Bid Conditions:**

In regard to these Bid Conditions, if the contractor meets the goals set forth therein or can demonstrate that it has made every good faith effort to meet these goals, the contractor shall be presumed to be in compliance with Article III, Division 2, Chapter 28 of the Revised Municipal Code, the implementing regulations and its obligations under these Bid Conditions. In the event, no formal sanctions or proceedings leading toward sanctions shall be instituted unless the contracting or administering agency otherwise determines that the contractor is violating the Equal Opportunity Clause.

1. Where the Office of Contract Compliance finds that a contractor failed to comply with the requirements of Article III, Division 2, Chapter 28 of the Revised Municipal Code or the implementing regulations and the obligations under these Bid Conditions, and so informs the Manager, the Manager shall take such action and impose such sanctions, which include suspension, termination, cancellation, and debarment, as may be appropriate under the Ordinance and its regulations. When the Manager proceeds with such formal action it has the burden of proving that the contractor has not met the goals contained in these Bid Conditions. The contractor's failure to meet its goals shall shift to it the requirement to come forward with evidence to show that it has met the good faith requirements of these Bid Conditions.

2. The pendency of such proceedings shall be taken into consideration by the Department of Public Works in determining whether such contractor can comply with the requirements of Article III, Division 2, Chapter 28 of the Revised Municipal Code, and is therefore a "responsible prospective contractor".

Revised: 09/26/90

EEO-F7

3. The Mayor's Office of Contract Compliance shall review the contractor's employment practices during the performance of the contract. If the Mayor's Office of Contract Compliance determines that the contractor's Affirmative Action Plan is no longer an acceptable program, the Director shall notify the Manager.

B. **Obligations Applicable to Contractors:**

It shall be no excuse that the union with which the contractor has a collective bargaining agreement providing for exclusive referral failed to refer minority or female employees. Discrimination in referral for employment, even if pursuant to provisions of a collective bargaining agreement, is prohibited by the National Labor Relations Act, as amended, Title VI of the Civil Rights Act of 1964, as amended, and Article III, Division 2, Chapter 28 of the Revised Municipal Code. It is the policy of the Department of Public Works that contractors have a responsibility to provide equal employment opportunity, if they wish to participate in City and County of Denver contracts. To the extent they have delegated the responsibility for some of their employment practices to a labor organization and, as a result, are prevented from meeting their obligations pursuant to Article III, Division 2, Chapter 28 of the Revised Municipal Code, such Contractors cannot be considered to be in compliance with Article III, Division 2, Chapter 28 of the Revised Municipal Code, or its implementing rules and regulations.

Revised: 10/19/93

EEO-F8

C. **General Requirements**

Contractors are responsible for informing their subcontractors in writing regardless of tier, as to their respective obligations. Whenever a contractor subcontracts a portion of work in any trade covered by these Bid Conditions, it shall include these Bid Conditions in such subcontracts and each subcontractor shall be bound by these Bid Conditions to the full extent as if it were the prime contractor. The contractor shall not, however, be held accountable for the failure of its subcontractors to fulfill their obligations under these Bid Conditions. However, the prime contractor shall give notice to the Director of any refusal or failure of any subcontractor to fulfill the obligations under these Bid Conditions. A subcontractor's failure to comply will be treated in the same manner as such failure by a prime contractor.

1. Contractors hereby agree to refrain from entering into any contract or contract modification subject to Article III, Division 2, Chapter 28 of the Revised Municipal Code with a contractor debarred from, or who is determined not to be a "responsive" bidder for the City and County of Denver contracts pursuant to the Ordinance.

2. The contractor shall carry out such sanctions and penalties for violation of these Bid Conditions and the Equal Opportunity Clause including suspension, termination and cancellation of existing subcontracts and debarment from future contracts as may be ordered by the Manager pursuant to Article III, Division 2, Chapter 28 of the Revised Municipal Code and its implementing regulations.

Revised: 04/12/91

EEO-F9

Nothing herein is intended to relieve any contractor during the term of its contract from compliance with Article III, Division 2, Chapter 28 of the Revised Municipal Code, and the Equal Opportunity Clause of its contract with respect to matters not covered in these Bid Conditions.

3. Contractors must keep such records and file such reports relating to the provisions of these Bid Conditions as shall be required by the Office of Contract Compliance.

4. Requests for exemptions from these Bid Conditions must be made in writing, with justification, to the Manager of Public Works, City and County Building, Room 379, Denver, Colorado 80202, and shall be forwarded through and with the endorsement of the Director.

Revised: 04/12/91

EEO-F10

**CITY AND COUNTY OF DENVER
CONTRACT NO. 202263315**

CONNECTING AURARIA

CONTRACT

THIS CONTRACT AND AGREEMENT, made and entered into by and between the City and County of Denver, a municipal corporation of the State of Colorado, hereinafter referred to as the "City," party of the first part, and contractor listed below, hereinafter referred to as the "Contractor," party of the second part,

**HAMON INFRASTRUCTURE, INC.
5670 FRANKLIN ST.
DENVER, CO 80216**

WITNESSETH, commencing on **June 6, 2022**, and for at least three (3) days the City advertised that sealed bids would be received for furnishing all labor, tools, supplies, equipment, materials, and everything necessary and required for the following:

| |
|---|
| <p>CONTRACT NO. 202263315 CONNECTING AURARIA</p> |
|---|

WHEREAS, bids pursuant to said advertisement have been received by the Manager of the Department of Transportation and Infrastructure, who has recommended that a Contract for said work be made and entered into with the above-named Contractor who was the lowest, responsive, qualified bidder therefore, and

WHEREAS, said Contractor is now willing and able to perform all of said work in accordance with said advertisement and its bid.

NOW THEREFORE, in consideration of the compensation to be paid the Contractor, the mutual agreements hereinafter contained, and subject to the terms hereinafter stated, it is mutually agreed as follows:

1. CONTRACT DOCUMENTS

It is agreed by the parties hereto that the following list of documents, instruments, technical specifications, plans, drawings and other materials which are attached hereto and bound herewith, incorporated herein by reference or otherwise referenced in these documents constitute and shall be referred to either as the "Contract Documents" or the "Contract," and all of said documents, instruments, technical specifications, Plans, Drawings and other materials taken together as a whole constitute the Contract between the parties hereto, and they are as fully a part of this agreement as if they were set out verbatim and in full herein:

Advertisement of Notice of Invitation for Bids

Instructions to Bidders

Commitment to MWBE Participation

Letters(s) of Intent

IA - List of Proposed Subcontractors, Subconsultants, and/or Suppliers

Article III, Divisions 1, 2, and 3 of Chapter 28, D.R.M.C.

Bid Bond

Addenda (as applicable)

Equal Employment Opportunity Provisions (Appendix A and Appendix F)

Bid Form

Contract Form

General Contract Conditions
Special Contract Conditions
Performance and Payment Bond
Notice to Apparent Low Bidder
Notice to Proceed
Contractor's Certification of Payment Form
Final/Partial Release and Certificate of Payment
Certificate of Contract Release
Change Orders (as applicable)
Federal Requirements (as applicable)
Prevailing Wage Rate Schedule(s)
Technical Specifications
Contract Drawings
Accepted Shop Drawings

2. SCOPE OF WORK

The Contractor agrees to and shall furnish all labor, tools, supplies, equipment, materials and everything necessary for and required to do, perform and complete all of the Work described, drawn, set forth, shown and included in said Contract Documents.

3. TERMS OF PERFORMANCE

The Contractor agrees to undertake the performance of the Work under this Contract within ten (10) days after being notified to commence work by issuance of a Notice to Proceed in substantially the form contained herein from the Manager and agrees to fully complete said Work within **300 (Three Hundred)** consecutive calendar days from the effective date of said Notice, plus such extension or extensions of time as may be granted in accordance with the provisions of the General Contract Conditions and any applicable Special Contract Conditions.

4. TERMS OF PAYMENT

The City agrees to pay the Contractor for the performance of all of the Work required under this Contract, and the Contractor agrees to accept as the Contractor's full and only compensation therefore, such sum or sums of money as may be proper in accordance with the price or prices set forth in the Contractor's Bid Form hereto attached and made a part hereof for **bid item numbers 201-00001 through LS2 (One Hundred Ninety-One [175]) bid items**, the total estimated cost thereof being **Six Million Three Hundred Forty-Five Thousand Nine Hundred and Ninety-Seven Dollars and Two Cents (\$6,345,997.02)**. Adjustments to said Contract Amount and payment of amounts due hereunder shall be made in accordance with the provisions of the General Contract Conditions and any applicable Special Contract Conditions.

5. NO DISCRIMINATION IN EMPLOYMENT

In connection with the performance of work under the Agreement, the Contractor may not refuse to hire, discharge, promote, demote, or discriminate in matters of compensation against any person otherwise qualified, solely because of race, color, religion, national origin, ethnicity, citizenship, immigration status, gender, age, sexual orientation, gender identity, gender expression, marital status, source of income, military status, protective hairstyle, or disability. The Contractor shall insert the foregoing provision in all subcontracts.

6. COMPLIANCE WITH MWBE REQUIREMENTS

This Contract is subject to all applicable provisions of Divisions 1 and 3 of Article III, of Chapter 28, Denver Revised Municipal Code (D.R.M.C.) referred to in this Contract as the "MWBE Ordinance" any corresponding Rules and Regulations, and any additional requirements contained herein. Without limiting

the general applicability of the foregoing, the Contractor/Consultant acknowledges its continuing duty, pursuant to the D.R.M.C., to maintain throughout the duration of this Contract, and compliance with the MWBE commitment of **20.49%**, upon which the City approved the award of this Contract to the Contractor/Consultant. The Contractor/Consultant further acknowledges that failure to maintain such participation commitments or otherwise comply with the requirements of the MWBE Ordinance, any corresponding Rules and Regulations, and any additional requirements contained herein, shall subject the Contractor/Consultant to sanctions in accordance with Section 28-76 of the D.R.M.C. Nothing contained in this provision or in the MWBE Ordinance shall negate the City's right to prior approval of subcontractors, or substitutes therefore, under this Contract.

7. WAGE RATE REQUIREMENTS

In performance of all Work hereunder, the Contractor agrees to comply with and be bound by all requirements and conditions of the City's Payment of Prevailing Wages Ordinance, Sections 20-76 through 20-79, D.R.M.C. and any determinations made by the City pursuant thereto as well as the City's Minimum Wage Protections Sections 20-82 through 20-84 D.R.M.C. and any determinations made by the City pursuant thereto. In the event a covered worker falls under both ordinances, Contractor shall pay the greater of the two rates.

8. APPLICABILITY OF LAWS

The Agreement between the Contractor and the City shall be deemed to have been made in the City and County of Denver, State of Colorado and shall be subject to, governed by, and interpreted and construed by or in accordance with the laws of the State of Colorado and the Charter, Revised Municipal Code, Rules, Regulations, Executive Orders, Health Orders and fiscal rules of the City. As such, the Contractor shall at all times comply with the provisions of the Charter, Revised Municipal Code, Rules, Regulations, Executive Orders and fiscal rules of the City, and those State of Colorado and Federal Laws, Rules and Regulations, which in any manner limit, control or apply to the actions or operations of the Contractor, any subcontractors, employees, agents or servants of the Contractor engaged in the Work or affecting the materials and equipment used in the performance of the Work, as the same may be, from time to time, promulgated, revised or amended. The Charter and Revised Municipal Code of the City and County of Denver, as the same may be amended from time to time, are hereby expressly incorporated into this Agreement as if fully set out herein by this reference. Without limiting the generality of the foregoing, the Contractor shall comply with any and all applicable public emergency or public health orders issued by any federal, state, municipal or local governmental entity, or any department or agency thereof, including the Colorado Department of Public Health & Environment (CDPHE) and the Denver Department of Public Health & Environment (DDPHE).

9. APPROPRIATION

The amount of money, which has been appropriated and encumbered for the purpose of this contract, to date, is equal to or in excess of the Contract Amount. The Manager, upon reasonable written request, will advise the Contractor in writing of the total amount of appropriated and encumbered funds, which remain available for payment for all Work under the Contract.

The issuance of any change order or other form or order or directive by the City which would cause the aggregate payable under the contract to exceed the amount appropriated for the contract is expressly prohibited. In no event shall the issuance of any change order or other form of order or directive by the City be considered valid or binding if it requires additional compensable work to be performed, which work will cause the aggregate amount available under the Contract to exceed the amount appropriated and encumbered for this Contract, unless and until such time as the Contractor has been advised in writing by the Manager that a lawful appropriation, sufficient to cover the entire cost of such additional work, has been made.

It shall be the responsibility of the Contractor to verify that the amounts already appropriated for this Contract are sufficient to cover the entire cost of such work, and any work undertaken or performed in excess of the amount appropriated is undertaken or performed in violation of the terms of this contract, without the proper authorization for such work, and at the Contractor's own risk.

10. [RESERVED]

11. ASSIGNMENT

The Contractor shall not assign any of its rights, benefits, obligations or duties under this Contract except upon the prior written consent and approval of the Manager to such assignment.

12. DISPUTES RESOLUTION PROCESS

It is the express intention of the parties to this Contract that all disputes of any nature whatsoever regarding the Contract including, but not limited to, any claims for compensation or damages arising out of breach or default under this Contract, shall be resolved by administrative hearing pursuant to the provisions of Section 56-106, D.R.M.C., or, as applicable, Section 28-69 D.R.M.C. for Minority and Women-Owned Business Enterprise disputes. The Contractor expressly agrees that this dispute resolution process is the only dispute resolution mechanism that will be recognized by the parties for any claims put forward by the Contractor, notwithstanding any other claimed theory of entitlement on the part of the Contractor or its subcontractors or suppliers.

13. CONTRACT BINDING

It is agreed that this Contract shall be binding on and inure to the benefit of the parties hereto, their heirs, executors, administrators, assigns and successors.

14. PARAGRAPH HEADINGS

The captions and headings set forth herein are for convenience of reference only and shall not be construed so as to define or limit the terms and provisions hereof.

15. SEVERABILITY

It is understood and agreed by the parties hereto that, if any part, term, or provision of this Contract, except for the provisions of this Contract requiring prior appropriation and limiting the total amount to be paid by the City, is by the courts held to be illegal or in conflict with any law of the State of Colorado, the validity of the remaining portions or provisions shall not be affected, and the rights and obligations of the parties shall be construed and enforced as if the Contract did not contain the particular part, term or provision held to be invalid.

16. ELECTRONIC SIGNATURES AND ELECTRONIC RECORDS

Contractor consents to the use of electronic signatures by the City. The Agreement, and any other documents requiring a signature hereunder, may be signed electronically by the City in the manner specified by the City. The Parties agree not to deny the legal effect or enforceability of the Agreement solely because it is in electronic form or because an electronic record was used in its formation. The Parties agree not to object to the admissibility of the Agreement in the form of an electronic record, or a paper copy of an electronic document, or a paper copy of a document bearing an electronic signature, on the ground that it is an electronic record or electronic signature or that it is not in its original form or is not an original.

[REMAINDER OF PAGE INTENTIONALLY LEFT BLANK]

Contract Control Number: DOTI-202263315-00
Contractor Name: Hamon Infrastructure, Inc.

IN WITNESS WHEREOF, the parties have set their hands and affixed their seals at Denver, Colorado as of:

SEAL

CITY AND COUNTY OF DENVER:

ATTEST:

By:

APPROVED AS TO FORM:

REGISTERED AND COUNTERSIGNED:

Attorney for the City and County of Denver

By:

By:

By:

Contract Control Number:
Contractor Name:

DOTI-202263315-00
Hamon Infrastructure, Inc.

By: _____
DocuSigned by:
Ryan Mastrianni
24GF3A799D124F1...

Name: _____
Ryan Mastrianni
(please print)

Title: _____
Vice-Secretary
(please print)

ATTEST: [if required]

By: _____

Name: _____
(please print)

Title: _____
(please print)

**STANDARD SPECIFICATIONS FOR CONSTRUCTION
GENERAL CONTRACT CONDITIONS (INDEX)**

| | Page Number |
|--|--------------|
| TITLE 1 - DEFINITIONS | 1 |
| 101 CITY | 1 |
| 102 CONTRACT | 1 |
| 103 CONTRACT AMOUNT | 1 |
| 104 CONTRACT DOCUMENTS | 1 |
| 105 CONTRACT TIME | 1 |
| 106 CONTRACTOR | 2 |
| 107 CONTRACTOR PERSONNEL | 2 |
| 108 DAYS | 2 |
| 109 DEPUTY MANAGER | 2 |
| 110 DESIGNER | 2 |
| 111 FINAL COMPLETION | 2 |
| 112 MANAGER | 3 |
| 113 PRODUCT DATA | 3 |
| 114 PROJECT | 3 |
| 115 PROJECT MANAGER | 3 |
| 116 SAMPLES | 3 |
| 117 SHOP DRAWINGS | 3 |
| 118 SUBCONTRACTOR | 3 |
| 119 SUBSTANTIAL COMPLETION | 3 |
| 120 SUPPLIER | 4 |
| 121 WORK | 4 |
| TITLE 2 – CITY ADMINISTRATIVE ORGANIZATIONS; LINE OF AUTHORITY..... | 5 |
| 201 DEPARTMENT OF AVIATION | 5 |
| 202 MANAGER OF AVIATION | 5 |
| 203 DEPARTMENT OF PUBLIC WORKS | 5 |
| 204 MANAGER OF PUBLIC WORKS | 5 |
| 205 BUILDING INSPECTION | 5 |
| 206 ZONING | 5 |
| 207 DIVISION OF SMALL BUSINESS OPPORTUNITY | 6 |
| 208 CITY AUDITOR | 6 |
| 209 MANAGER OF FINANCE | 6 |
| 210 CITY ATTORNEY | 6 |
| 211 OFFICE OF RISK MANAGEMENT | 6 |
| 212 CITY'S CONTRACT ADMINISTRATION LINE OF AUTHORITY | 6 |
| 213 CITY'S COMMUNICATIONS WITH THE CONTRACTOR | 7 |
| TITLE 3 - CONTRACTOR PERFORMANCE AND SERVICES | 8 |
| 301 CONSIDERATION (CONTRACTOR'S PROMISE OF PERFORMANCE) | 8 |
| 302 NOTICE TO PROCEED AND COMPLETION OF THE WORK | 8 |
| 303 EXACT CONTRACTOR PERFORMANCE | 8 |
| 304 SUBSTITUTED PERFORMANCE | 8 |
| 305 WORK PERFORMED UNDER ADVERSE WEATHER CONDITIONS | 9 |
| 306 WORKING HOURS AND SCHEDULE | 9 |
| 307 CONTRACTOR'S SUPERINTENDENT | 10 |
| 308 COMMUNICATIONS | 10 |

| | | |
|--|---|-----------|
| 309 | CONTRACTOR SUBMITTALS AND OTHER WRITTEN COMMUNICATIONS TO THE CITY..... | 10 |
| 310 | COMPETENCE OF CONTRACTOR'S WORK FORCE..... | 11 |
| 311 | NO EMPLOYMENT OF ILLEGAL ALIENS TO PERFORM WORK UNDER THE CONTRACT..... | 11 |
| 312 | CONDUCT OF CONTRACTOR'S PERSONNEL..... | 12 |
| 313 | SUGGESTIONS TO CONTRACTOR..... | 12 |
| 314 | WORK FORCE..... | 12 |
| 315 | CONSTRUCTION MACHINES AND STANBY EQUIPMENT..... | 13 |
| 316 | CUTTING AND PATCHING THE WORK..... | 13 |
| 317 | PERMITS AND LICENSES..... | 13 |
| 318 | CONSTRUCTION SURVEYS..... | 14 |
| 319 | PRESERVATION OF PERMANENT LAND SURVEY CONTROL MARKERS..... | 14 |
| 320 | TRADEMARKS, COPYRIGHTS AND PATENTED DEVICES, MATERIALS, AND PROCESSES..... | 15 |
| 321 | PROJECT SIGNS..... | 15 |
| 322 | PUBLICITY AND ADVERTISING..... | 16 |
| 323 | TAXES..... | 16 |
| 324 | DOCUMENTS AND SAMPLES AT THE SITE..... | 17 |
| 325 | CLEANUP DURING CONSTRUCTION..... | 17 |
| 326 | SANITARY FACILITIES..... | 18 |
| 327 | POWER, LIGHTING, HEATING, VENTILATING, AIR CONDITIONING AND WATER SERVICES..... | 18 |
| TITLE 4 - CONTRACT DOCUMENTS (DRAWINGS AND SPECIFICATIONS)..... | | 19 |
| 401 | CONTRACT DOCUMENTS - REVIEW AND INTERPRETATION..... | 19 |
| 402 | OWNERSHIP OF CONTRACT DRAWINGS AND TECHNICAL SPECIFICATIONS..... | 20 |
| 403 | CONTRACT DRAWINGS AND TECHNICAL SPECIFICATIONS ISSUED TO THE CONTRACTOR..... | 20 |
| 404 | REQUESTS FOR INFORMATION OR CLARIFICATION..... | 21 |
| 405 | SHOP DRAWINGS, PRODUCT DATA AND SAMPLES..... | 21 |
| 406 | SUBSTITUTION OF MATERIALS AND EQUIPMENT..... | 22 |
| TITLE 5 - SUBCONTRACTS..... | | 24 |
| 501 | SUBCONTRACTS..... | 24 |
| 502 | SUBCONTRACTOR ACCEPTANCE..... | 24 |
| TITLE 6 - TIME OF COMMENCEMENT AND COMPLETION..... | | 27 |
| 601 | BEGINNING, PROGRESS AND TIME OF COMPLETION..... | 27 |
| 602 | LIQUIDATED DAMAGES, ADMINISTRATIVE COSTS; ACTUAL DAMAGES..... | 27 |
| 603 | DELAY DAMAGES..... | 28 |
| TITLE 7 - COOPERATION, COORDINATION AND RATE OF PROGRESS..... | | 29 |
| 701 | COOPERATION WITH OTHER WORK FORCES..... | 29 |
| 702 | COORDINATION OF THE WORK..... | 30 |
| 703 | COORDINATION OF PUBLIC CONTACT..... | 30 |
| 704 | RATE OF PROGRESS..... | 30 |
| TITLE 8 - PROTECTION OF PERSONS AND PROPERTY..... | | 32 |
| 801 | SAFETY OF PERSONS..... | 32 |
| 802 | PROTECTIVE DEVICES AND SAFETY PRECAUTIONS..... | 33 |

| | | |
|--|--|-----------|
| 803 | PROTECTION OF PROPERTY AND WORK IN PROGRESS | 33 |
| 804 | PROTECTION OF MUNICIPAL, PUBLIC SERVICE OR UTILITY SYSTEMS | 34 |
| 805 | PROTECTION OF STREET AND ROAD SYSTEM | 35 |
| 806 | PROTECTION OF DRAINAGE WAYS | 36 |
| 807 | PROTECTION OF THE ENVIRONMENT | 36 |
| 808 | HAZARDOUS AND EXPLOSIVE MATERIALS OR SUBSTANCES | 37 |
| 809 | ARCHEOLOGICAL AND HISTORICAL DISCOVERIES | 37 |
| TITLE 9 - COMPENSATION..... | | 38 |
| 901 | CONSIDERATION (CITY'S PROMISE TO PAY)..... | 38 |
| 902 | PAYMENT PROCEDURE | 38 |
| 903 | SCHEDULE OF VALUES IN LUMP SUM CONTRACTS..... | 39 |
| 904 | UNIT PRICE CONTRACTS..... | 39 |
| 905 | PROGRESS PERIOD..... | 39 |
| 906 | APPLICATIONS FOR PAYMENT | 40 |
| 907 | RELEASES AND CONTRACTORS CERTIFICATION OF PAYMENT | 41 |
| 908 | RETAINAGE | 41 |
| 909 | ADDITIONAL WITHHOLDING OF PROGRESS PAYMENTS..... | 42 |
| 910 | FINAL ESTIMATE AND PAYMENT | 43 |
| 911 | ACCOUNTING OF COSTS AND AUDIT | 43 |
| TITLE 10 - WAGES..... | | 45 |
| 1001 | PREVAILING WAGE ORDINANCE | 45 |
| 1002 | POSTING OF THE APPLICABLE WAGE RATES | 45 |
| 1003 | RATE AND FREQUENCY OF WAGES PAID | 45 |
| 1004 | REPORTING WAGES PAID..... | 45 |
| 1005 | FAILURE TO PAY PREVAILING WAGES | 46 |
| TITLE 11 - CHANGES IN THE WORK, CONTRACT PRICE OR CONTRACT TIME | | 47 |
| 1101 | CHANGE ORDER | 47 |
| 1102 | CITY INITIATED CHANGES | 47 |
| 1103 | CONTRACTOR CHANGE REQUEST | 48 |
| 1104 | ADJUSTMENT TO CONTRACT AMOUNT | 51 |
| 1105 | TIME EXTENSIONS | 54 |
| TITLE 12 - CONTRACTOR CLAIMS FOR ADJUSTMENT AND DISPUTES..... | | 56 |
| 1201 | NOTICE OF INTENT TO CLAIM | 56 |
| 1202 | SUBMITTAL OF CLAIMS | 56 |
| 1203 | WAIVER OF CLAIMS | 58 |
| TITLE 13 - DISPUTES | | 59 |
| 1301 | DISPUTES..... | 59 |
| TITLE 14 - SITE CONDITIONS | | 60 |
| 1401 | DIFFERING SITE CONDITIONS..... | 60 |
| 1402 | SITE INSPECTIONS AND INVESTIGATIONS | 60 |

TITLE 15 - PERFORMANCE AND PAYMENT BONDS.....62

1501 SURETY BONDS62

1502 PERFORMANCE BOND.....62

1503 PAYMENT BOND.....62

TITLE 16 - INSURANCE AND INDEMNIFICATION.....63

1601 INSURANCE.....63

1602 DEFENSE AND INDEMNIFICATION.....63

TITLE 17 - INSPECTION AND DEFECTS64

1701 CONSTRUCTION INSPECTION BY THE CITY.....64

1702 AUTHORITY OF INSPECTORS64

1703 OBSERVABLE DEFECTS64

1704 DEFECTS - UNCOVERING WORK64

1705 LATENT DEFECTS65

1706 REMOVAL OF DEFECTIVE MATERIALS AND WORK.....65

TITLE 18 - WARRANTIES, GUARANTEES AND CORRECTIVE WORK.....66

1801 CONTRACTOR'S WARRANTIES, GUARANTEES AND CORRECTION OF
WORK.....66

1802 PERFORMANCE DURING WARRANTY PERIOD67

TITLE 19 - SUBSTANTIAL COMPLETION OF THE WORK69

1901 CONTRACTOR'S NOTICE OF SUBSTANTIAL COMPLETION.....69

1902 INSPECTION AND PUNCH LIST.....69

1903 CERTIFICATE OF SUBSTANTIAL COMPLETION69

1904 RIGHT OF EARLY OCCUPANCY OR USE.....69

TITLE 20 - FINAL COMPLETION AND ACCEPTANCE OF WORK71

2001 CLEAN-UP UPON COMPLETION71

2002 FINAL COMPLETION AND ACCEPTANCE OF THE WORK.....71

2003 FINAL SETTLEMENT71

TITLE 21 - SUSPENSION OF WORK74

2101 SUSPENSION OF WORK74

2102 SUSPENSION OF THE WORK FOR THE CITY'S CONVENIENCE.....74

2103 SUSPENSION BECAUSE OF ORDER OF CITY, STATE OR FEDERAL COURT
OR AGENCY75

2104 SUSPENSION RESULTING FROM CONTRACTOR'S FAILURE TO PERFORM75

TITLE 22 - CITY'S RIGHT TO TERMINATE THE CONTRACT76

2201 TERMINATION OF CONTRACT FOR CAUSE.....76

2202 TERMINATION OF CONTRACT FOR CONVENIENCE OF THE CITY77

TITLE 23 - MISCELLANEOUS PROVISIONS80

2301 PARTIES TO THE CONTRACT.....80

2302 FEDERAL AID PROVISIONS80

| | | |
|--------------------|--|-------------|
| 2303 | NO WAIVER OF RIGHTS | 80 |
| 2304 | NO THIRD PARTY BENEFICIARY | 80 |
| 2305 | GOVERNING LAW; VENUE | 80 |
| 2306 | ABBREVIATIONS | 81 |
| 2307 | STATUTE OF LIMITATIONS IN C.R.S. § 13-80-102(1)(h) | 81 |
| INDEX | | i-ix |

[REMAINDER OF PAGE INTENTIONALLY LEFT BLANK]

CITY AND COUNTY OF DENVER
SPECIAL CONTRACT CONDITIONS

SC-1 CONSTRUCTION SPECIFICATIONS

Except as amended herein or in the attached/incorporated Technical Specifications, all Work performed under the terms of this Contract shall be governed by the applicable provisions of the following latest editions:

City and County of Denver:

Standard Specifications for Construction, GENERAL CONTRACT CONDITIONS,
(2011 Edition)

Transportation Standards and Details for the Engineering Division

City and County of Denver Traffic Standard Drawings

Wastewater Capital Projects Management

<https://www.denvergov.org/content/denvergov/en/wastewater-management/capital-projects-management.html>

Colorado Department of Transportation:

Standard Specifications for Road and Bridge Construction
(Sections 200 through 700 of the 2019 Edition)

Federal Highway Administration:

Manual on Uniform Traffic Control Devices for Streets & Highways (MUTCD)

Building & Fire Codes:

Building Code of the City and County of Denver

(International Building Code 2018 Series, City and County of Denver Amendments 2019)

<https://www.denvergov.org/content/denvergov/en/denver-development-services/help-me-find/building-codes-and-policies.html>

National Fire Protection Association Standards

(As referenced in the Building Code of the City and County of Denver)

The *Standard Specifications for Construction, GENERAL CONTRACT CONDITIONS* is available at:

<https://www.denvergov.org/content/denvergov/en/contract-administration/contractor-resources.html>

Transportation Standards and Details for the Engineering Division and the Wastewater Management Division – *Standard Detail Drawings*, are available at <http://www.denvergov.org>.

The “*Colorado Department of Transportation Standard Specifications for Road and Bridge Construction*” is available for review on CDOT’s website at:

<https://www.codot.gov/business/designsupport/cdot-construction-specifications/2021-construction-specifications/2021-specs-book>.

The *Manual on Uniform Traffic Control Devices for Streets & Highways* is available for review at the Federal Highway Administration Website at: www.fhwa.dot.gov, The FHWA website also contains purchasing information.

SC-2 DEPARTMENT OF TRANSPORTATION AND INFRASTRUCTURE (REPLACES GENERAL CONTRACT CONDITION 203)

As of January 1, 2020, the functions of Public Works are housed in the new Department of Transportation and Infrastructure. For purposes of this Contract all references (including, but not limited to, references appearing in the body of the contract, General Conditions, Special Conditions, Exhibits, Contract Documents or Policies and Procedures) to the Department of Public Works will have the same meaning as the Department of Transportation and Infrastructure.

Vested exclusively in the Department of Transportation and Infrastructure is the management and control of the design and construction of general and local public improvements undertaken by the City and County of Denver, except for: (i) work which is under the management and control of the Department of Aviation; (ii) that work performed by the Denver Board of Water Commissioners; (iii) any such work that the Mayor has specifically assigned to another department or agency; and (iv) work under the authority of the Department of Transportation and Infrastructure that is performed with the permission of the Manager of Transportation and Infrastructure by private entities at their own expense.

SC-3 MANAGER OF DEPARTMENT OF TRANSPORTATION AND INFRASTRUCTURE (REPLACES GENERAL CONTRACT CONDITION 204)

General Condition 204 "Manager of Public Works" is hereby deleted in its entirety and replaced with the following:

As of January 1, 2020, the functions of Public Works are housed in the new Department of Transportation and Infrastructure. The Manager of Public Works / Executive Director of Public Works will become the Executive Director of Transportation and Infrastructure. Manager of Public Works, Executive Director of Public Works, Executive Director of Transportation and Infrastructure and Manager of Transportation and Infrastructure will have the same meaning for purposes of this Agreement.

SC-4 DEPUTY MANAGER / CITY ENGINEER

General condition 109 DEPUTY MANAGER is hereby deleted in its entirety and replaced with the following:

The "Deputy Manager" means the official who reports directly to the Manager and exercises supervisory responsibility in the City agency defined in Title 2 herein that is responsible for the Project. The Manager hereby designates the City Engineer as the Deputy Manager for purposes of this Contract. The City Engineer shall have responsibility for this Project and shall undertake all duties, responsibilities, rights and authority, including specific actions and decisions, delegated to the Deputy Manager under the various terms and conditions of this Contract.

SC-5 PROJECT DELIVERY ADMINISTRATION / CITY ENGINEER

Project Delivery Administration is a division of the Department of Transportation and Infrastructure and is supervised by the City Engineer, who is subordinate to the Manager of Transportation and Infrastructure. This Division is responsible for the planning, design, construction, operation and maintenance of all of the City's transportation facilities and the planning, design and construction of all of the City's wastewater facilities, except for the City's Municipal Airport System. All other references to the Transportation Division or the Deputy Manager of Public Works are deleted and replaced with references to the Engineering Division and the City Engineer, respectively.

SC-6 CITY DELEGATION OF AUTHORITY

With reference to General Contract Condition 109, DEPUTY MANAGER and General Contract Condition 212, CITY'S CONTRACT ADMINISTRATION LINE OF AUTHORITY, the Manager hereby designates the City Engineer as the City official responsible for those certain actions and decisions designated as the

responsibility of the Deputy Manager under the General Conditions and delegates to the City Engineer the authority necessary to undertake those responsibilities under this Contract. The City Engineer shall have supervisory responsibility over the Project Manager. Additionally, Contractor questions concerning the Plans and Technical Specifications shall be directed to:

Department of Transportation and Infrastructure:

| | |
|------------------------|------------------|
| <u>Project Manager</u> | <u>Telephone</u> |
| Steve Laudeman | 720.913.4549 |

| | | |
|--------------------|-------------|------------------|
| <u>Consultant</u> | <u>Name</u> | <u>Telephone</u> |
| Wilson and Company | Marc Devos | 303.919.0386 |

SC-7 PREVAILING WAGES

General Contract Condition 1003 RATE AND FREQUENCY OF WAGES PAID (.2), is hereby deleted in its entirety and replaced with the following:

(.2) Weekly, the Contractor and all of its Subcontractors shall pay all workers, mechanics, and laborers according to the rates and classifications established in the Contract Documents. Increases in prevailing wages subsequent to the date of the contract for a period not to exceed one (1) year shall not be mandatory on either the contractor or subcontractors. Future changes in prevailing wages on contracts whose period of performance exceeds one (1) year shall be mandatory for the contractor and subcontractors only on the yearly anniversary of the actual date of bid or proposal issuance, if applicable, or the date of the written encumbrance if no bid/proposal issuance date is applicable. Except as provided below, in no event shall any increases in prevailing wages over the amounts thereof as stated in such specifications result in any increased liability on the part of the city, and the possibility and risk of any such increase is assumed by all contractors entering into any such contract with the city. Notwithstanding the foregoing, the city may determine and may expressly provide in the context of specific agreements that the city will reimburse the contractor at the increased prevailing wage rate(s).

Date bid or proposal issuance was advertised **June 6, 2022**.

Contractor shall provide the Auditor with a list of all subcontractors providing any services under the contract.

Contractor shall provide the Auditor with electronically certified payroll records for all covered workers employed under the contract.

Contractor shall prominently post at the work site the current prevailing wage and fringe benefit rates. The posting must inform workers that any complaints regarding the payment of prevailing wages or fringe benefits may be submitted to the Denver Auditor by calling 720-913-5000 or emailing auditor@denvergov.org.

If Contractor fails to pay workers as required by the Prevailing Wage Ordinance, Contractor will not be paid until documentation of payment satisfactory to the Auditor has been provided. The City may, by written notice, suspend or terminate work if Contractor fails to pay required wages and fringe benefits.

SC-8 LIQUIDATED DAMAGES

Should the Contractor fail to complete all Work within the Contract Time allocated under the Contract Form at Paragraph 3, TERMS OF PERFORMANCE, the Contractor shall become liable to the City and County of Denver for liquidated damages, and not as a penalty, at the rate of **\$5,400.00** for each Day that

the Contractor exceeds the time limits herein specified, all in accordance with provisions of General Contract Condition 602, LIQUIDATED DAMAGES; ADMINISTRATIVE COSTS; ACTUAL DAMAGES.

Representative hourly rates for the City administrative costs described in General Contract Condition 602.2 shall be as follows for this Project:

| | |
|-------------------------|----------------|
| Project Manager | \$69 per hour |
| Project Engineer | \$63 per hour |
| Inspector | \$49 per hour |
| Surveying, if necessary | \$100 per hour |

SC-9 SUBCONTRACTS

In accordance with General Contract Condition 501, SUBCONTRACTS, no limit shall apply to that percentage of the Work, which may be sublet providing that the subcontractors receive prior approval in accordance with General Contract Condition 502, SUBCONTRACTOR ACCEPTANCE.

SC-10 PAYMENTS TO CONTRACTORS

The application for payment shall be submitted through Textura® Corporations Construction Management Website. Contractor recognizes and agrees that it shall be required to use the Textura® Construction Payment Management System (“Textura”) for this Project to request payment from the City and to pay all first tier subcontractors and suppliers and further record payment to all certified subcontractors or suppliers that are listed for participation towards any assigned SMWDBE program goal. Contractor further agrees that, to the fullest extent possible within Textura, the City shall be entitled to all non-Confidential records, reports, data and other information related to the project that are available to Contractor through Textura, including, but not limited to, information related to Contractor and subcontractor billings. To that end, Contractor agrees it will activate any available settings within Textura necessary to grant the City access to such non-Confidential information related to the contract and the project. Applications for payment shall be based on the Contract Unit Prices or the approved Schedule of Values described in GC 903.1

In accordance with General Contract Condition 902, PAYMENT PROCEDURE, the party(ies) responsible for review of all Pay Applications shall be:

| <u>Agency/Firm</u> | <u>Name</u> | <u>Telephone</u> |
|---|----------------|------------------|
| Department of Transportation and Infrastructure | Steve Laudeman | 720.913.4549 |

In accordance with General Contract Condition 906, APPLICATIONS FOR PAYMENT, each Application submitted shall include the following:

1. The estimate of Work completed shall be based on the approved schedule of values or unit prices, as applicable, and the percent of the Work complete.
2. Each Application for Payment shall include each and every independent subcontractor’s payroll information including pay dates and pay amounts.
3. The Contractor, and its subcontractors of all tiers who have performed work, shall also submit to the Auditor and other appropriate officials of the City prior to submitting the payment application, information required by General Contract Condition 1004, REPORTING WAGES PAID.
4. Starting with the second payment application, the payment applications shall be accompanied by a completed Contractors’ Certification of Payment Form (CCP), listing all first tier subcontractors and suppliers and all certified subcontractors or suppliers that are listed for participation towards any assigned SMWDBE program goal. The final payment application must be accompanied by an executed

Final/Partial Release and Certification of Payment Form and Certificate of Contract Release Form from the Contractor.

* If subcontractor or supplier payments are disbursed via Textura® CPM, those systems generated Final/ Partial Release of Certification Form and CCP forms are acceptable.

Title 20, 2003 Final Settlement, section .2, item F is modified to read as follows:

F. At time of request for final payment, Contractor shall submit a complete and final, unconditional waiver or release of any and all lien and claim rights for all labor, equipment, and material used or furnished to complete the Work in the form and format generated within the Textura CPM system. Contractor shall also return an executed Certificate of Contract Release (below), upon request from the City.

[REMAINDER OF PAGE INTENTIONALLY LEFT BLANK]

SC-11 CONTRACT FORMS

In accordance with the terms and conditions of the Contract Documents, the City requires the use of certain form documents in complying with or satisfying various obligations, notifications and conditions in contracting with the City or performing Work hereunder. These form documents are referenced by title throughout the Contract Documents for mandatory use as directed. The following are the forms that shall be utilized in accordance with the Contract Documents:

1. Performance and Payment Bond (Sample)
2. Performance and Payment Bond Surety Authorization Letter (Sample)
3. Contractor's Certification of Payment (Sample)
4. Final/Partial Release and Certificate of Payment Form (Sample)
5. Notice to Apparent Low Bidder (Sample)
6. Notice to Proceed (Sample)
7. Certificate of Contract Release (Sample)

SC-12 CONSTRUCTION INSPECTION BY THE CITY

General Condition 1701, CONSTRUCTION INSPECTION BY THE CITY, is modified as follows:

1701.1 Persons who are employees of the City or who are under contract to the City or the City as lessee will be assigned to inspect and test the Work. These persons may perform any tests and observe the Work to determine whether or not designs, materials used, manufacturing and construction processes and methods applied, and equipment installed satisfy the requirements of the drawings and specifications, accepted Shop Drawings, Product Data and Samples, and the General Contractor's warranties and guarantees. The General Contractor shall permit these inspectors unlimited access to the Work and provide means of safe access to the Work, which cost shall be included as a Cost of the Work without any increase to the Guaranteed Maximum Price. In addition, General Contractor shall provide whatever access and means of access are needed to off-site facilities used to store or manufacture materials and equipment to be incorporated into the Work and shall respond to any other reasonable request to further the inspector's ability to observe or complete any tests. Such inspections shall not relieve the General Contractor of any of its quality control responsibilities or any other obligations under the Contract. All inspections and all tests conducted by the City are for the convenience and benefit of the City. These inspections and tests do not constitute acceptance of the materials or Work tested or inspected, and the City may reject or accept any Work or materials at any time prior to the inspections pursuant to G.C. 2002, whether or not previous inspections or tests were conducted by the inspector or a City representative.

.2 Building Inspection will perform building code compliance inspections for structures designed for human occupancy. It is the General Contractor's responsibility to schedule and obtain these inspections. If a code compliance inspection results in identification of a condition which will be at variance to the Contract Documents, the General Contractor shall immediately notify the Project Manager and confirm such notification with formal correspondence no later than forty-eight (48) hours after the occurrence.

.3 When any unit of government or political subdivision, utility or railroad corporation is to pay a portion of the cost of the Work, its respective representatives shall have the right to inspect the Work. This inspection shall not make any unit of government or political subdivision, utility or railroad corporation a party to the Contract, and shall not interfere with the rights of either party.

SC-13 DISPOSAL OF NON-HAZARDOUS WASTE AT DADS

In accordance with the Landfill Agreement made between the City and Waste Management of Colorado, Inc., bidders will be required to haul dedicated loads (non-hazardous entire loads of waste) to the Denver-Arapahoe Disposal Site ("DADS") for disposal. DADS is located at Highway 30 and Hampden Avenue in Arapahoe County, Colorado. The City will pay all fees associated with such disposal, but the bidder shall be responsible for the costs of transporting the loads. Non-hazardous waste is defined as those substances and materials not defined or classified as hazardous by the Colorado Hazardous Waste Commission

pursuant to C.R.S. §25-15-101(6), as amended from time to time, and includes construction debris, soil and asbestos. Bidders shall not use Gun Club Road between I-70 and Mississippi Avenue as a means of access to DADS.

SC-14 PROHIBITION ON USE OF CCA-TREATED WOOD PRODUCTS

The use of any wood products pressure-treated with chromated copper arsenate (CCA) is prohibited. Examples of CCA-treated wood products include wood used in play structures, decks, picnic tables, landscaping timbers, fencing, patios, walkways and boardwalks.

SC-15 WAIVER OF: PART 8 OF ARTICLE 20 OF TITLE 13, COLORADO REVISED STATUTES

The Contractor specifically waives all the provisions of Part 8 of Article 20 of Title 13, Colorado Revised Statutes regarding defects in the Work under this Construction Contract.

SC-16 ATTORNEY'S FEES

Colorado Revised Statute 38-26-107 requires that in the event any person or company files a verified statement of amounts due and unpaid in connection with a claim for labor and materials supplied on this project, the City shall withhold from payments to the Contractor sufficient funds to insure the payment of any such claims. Should the City and County of Denver be made a party to any lawsuit to enforce such unpaid claims or any lawsuit arising out of or relating to such withheld funds, the Contractor agrees to pay to the City its costs and a reasonable attorney's fee which cost shall be included as a Cost of the Work.

Because the City Attorney Staff does not bill the City for legal services on an hourly basis, the Contractor agrees a reasonable fee shall be computed at the rate of one hundred dollars per hour of City Attorney time.

SC-17 INSURANCE

General Condition 1601 is hereby deleted in its entirety and replaced with the following:

(1) General Conditions: Contractor agrees to secure, at or before the time of execution of this Agreement, the following insurance covering all operations, goods or services provided pursuant to this Agreement. Contractor shall keep the required insurance coverage in force at all times during the term of the Agreement, including any extension thereof, during any warranty period, and for eight (8) years after the termination of the Agreement. The required insurance shall be underwritten by an insurer licensed or authorized to do business in Colorado and rated by A.M. Best Company as A-VIII or better. Each policy shall require notification to the City in the event any of the required policies be canceled or non-renewed before the expiration date thereof. Such written notice shall be sent to the parties identified in the Notices section of this Agreement. Such notice shall reference the City contract number listed on the signature page of this Agreement. Said notice shall be sent thirty (30) days prior to such cancellation or non-renewal unless due to non-payment of premiums for which notice shall be sent ten (10) days prior. If such written notice is unavailable from the insurer, Contractor shall provide written notice of cancellation, non-renewal and any reduction in coverage to the parties identified in the Notices section by certified mail, return receipt requested within three (3) business days of such notice by its insurer(s) and referencing the City's contract number. Contractor shall be responsible for the payment of any deductible or self-insured retention. The insurance coverages specified in this Agreement are the minimum requirements, and these requirements do not lessen or limit the liability of the Contractor. The Contractor shall maintain, at its own expense, any additional kinds or amounts of insurance that it may deem necessary to cover its obligations and liabilities under this Agreement.

(2) Proof of Insurance: Contractor may not commence services or work relating to this Agreement prior to placement of coverages required under this Agreement. Contractor certifies that the certificate of insurance, preferably an ACORD form, complies with all insurance requirements of this Agreement. The City requests that the City's contract number be referenced on the certificate of insurance.

The City's acceptance of a certificate of insurance or other proof of insurance that does not comply with all insurance requirements set forth in this Agreement shall not act as a waiver of Contractor's breach of this Agreement or of any of the City's rights or remedies under this Agreement. The City's Risk Management Office may require additional proof of insurance, including but not limited to policies and endorsements.

(3) Additional Insureds: For Commercial General Liability, Auto Liability and Excess Liability/Umbrella (if required), Contractor and subcontractor's insurer(s) shall include the City and County of Denver, its elected and appointed officials, employees and volunteers as additional insured.

(4) Waiver of Subrogation: For all coverages required under this Agreement, with the exception of Professional Liability, Contractor's insurer shall waive subrogation rights against the City.

(5) Subcontractors: All subconsultants, subcontractors, independent contractors, suppliers or other entities providing goods or services required by this Agreement shall be subject to all of the requirements herein. Contractor shall require all of its subcontractors and subconsultants of any tier to provide insurance coverage in types and amounts required by the Contractor, but in amounts of at least \$1,000,000 Commercial General Liability, Business Auto Liability insurance of \$1,000,000 combined single limit, statutory Workers' Compensation coverage, and \$1,000,000 professional liability for any subcontractor performing design or engineering work. Contractor agrees to provide proof of insurance for all such subcontractors, subconsultants, independent contractors, suppliers or other entities upon request by the City.

(6) Workers' Compensation and Employer's Liability Insurance: Contractor shall maintain the coverage as required by statute for each work location and shall maintain Employer's Liability insurance with limits of \$100,000 per occurrence for each bodily injury claim, \$100,000 per occurrence for each bodily injury caused by disease claim, and \$500,000 aggregate for all bodily injuries caused by disease claims.

(7) Commercial General Liability: Contractor shall maintain a Commercial General Liability insurance policy with minimum limits of \$1,000,000 for each bodily injury and property damage occurrence, \$2,000,000 products and completed operations aggregate (if applicable), and \$2,000,000 policy aggregate.

(8) Business Automobile Liability: Contractor shall maintain Business Automobile Liability, or its equivalent, with minimum limits of \$1,000,000 combined single limit applicable to all owned, hired and non-owned vehicles used in performing services under this Agreement. If transporting wastes, hazardous material, or regulated substances, Contractor shall carry a pollution coverage endorsement and an MCS 90 endorsement on their policy. Transportation coverage under the Contractors Pollution Liability policy shall be an acceptable replacement for a pollution endorsement to the Business Automobile Liability policy.

(9) Builder's Risk or Installation Floater: Contractor shall maintain limits equal to the completed value of the project. Coverage shall be written on an all risk, replacement cost basis including coverage for soft costs, flood and earth movement, if in a flood or quake zone, and, if applicable, equipment breakdown including testing. The City and County of Denver, Contractor, and subcontractors shall be Additional Named Insureds under the policy. Policy shall remain in force until acceptance of the project by the City.

(10) Professional Liability (Errors & Omissions): Contractor shall maintain minimum limits of \$1,000,000 per claim and \$1,000,000 policy aggregate limit. The policy shall be kept in force, or a Tail policy placed, for three (3) years for all contracts except construction contracts for which the policy or Tail shall be kept in place for eight (8) years.

(11) Additional Provisions:

(a) For claims-made coverage:

The retroactive date must be on or before the contract date or the first date when any goods or services were provided to the City, whichever is earlier.

(b) Contractor shall advise the City in the event any general aggregate or other aggregate limits are reduced below the required per occurrence limits. At their own expense, and where such general aggregate or other aggregate limits have been reduced below the required per occurrence limit, the Contractor will procure such per occurrence limits and furnish a new certificate of insurance showing such coverage is in force.

SC-18 GREENPRINT DENVER REQUIREMENTS

In accordance with the City and County of Denver Executive Order 123: Greenprint Denver Office and Sustainability Policy, as amended, Contractor shall adhere to sections of Executive Order 123 pertinent to the construction of the built environment. This includes but is not limited to: all construction and renovation of buildings shall follow instructions and memorandum for high performance buildings; horizontal projects shall include the use of fly ash concrete and recycled aggregate where possible; and, all projects shall recycle construction and demolition waste, and install materials that contain recycled content whenever possible using the U.S. Green Building Council Leadership in Energy and Environmental Design (LEED) as guidance. Non-hazardous solid waste that is eligible for reuse or recycling is not subject to the DADS disposal requirement defined in SC-13.

A completed “Greenprint Denver Closeout Form for Construction Projects” shall be delivered to the Project Manager as a submittal requirement of Final Acceptance.

<https://www.denvergov.org/content/denvergov/en/contract-administration/contractor-resources.html>

SC-19 RESERVED

SC-20 DEFENSE AND INDEMNIFICATION

Title 1602 is hereby deleted in its entirety and replaced with the following:

- (a) To the fullest extent permitted by law, the Contractor hereby agrees to defend, indemnify, reimburse and hold harmless City, its appointed and elected officials, agents and employees for, from and against all liabilities, claims, judgments, suits or demands for damages to persons or property arising out of, resulting from, or related to the work performed under this Agreement that are due to the negligence or fault of the Contractor or the Contractor’s agents, representatives, subcontractors, or suppliers (“Claims”). This indemnity shall be interpreted in the broadest possible manner consistent with the applicable law to indemnify the City.
- (b) Contractor’s duty to defend and indemnify City shall arise at the time written notice of the Claim is first provided to City regardless of whether suit has been filed and even if Contractor is not named as a Defendant.
- (c) Contractor will defend any and all Claims which may be brought or threatened against City and will pay on behalf of City any expenses incurred by reason of such Claims including, but not limited to, court costs and attorney fees incurred in defending and investigating such Claims or seeking to enforce this indemnity obligation. Such payments on behalf of City shall be in addition to any other legal remedies available to City and shall not be considered City’s exclusive remedy.

- (d) Insurance coverage requirements specified in this Agreement shall in no way lessen or limit the liability of the Contractor under the terms of this indemnification obligation. The Contractor shall obtain, at its own expense, any additional insurance that it deems necessary for the City's protection.
- (e) This defense and indemnification obligation shall survive the expiration or termination of this Agreement.

SC-21 CONSTRUCTION SURVEYS

Hereby Replaces General Contract Condition 318 General Contract Condition 318 CONSTRUCTION SURVEYS is hereby deleted in its entirety and replaced with the following:

The City does not take responsibility for the accuracy of any survey data provided by the City. The Contractor must establish and validate the accuracy of all survey data and ensure that all elements of the Work are correctly located. The Contractor must accurately determine and transfer the survey control information to the points of application to ensure that all elements of the Work are correctly located.

Any Work that the Contractor begins before confirming the reference points may be rejected. Should any reference points be obliterated or dislodged by operations that the Contractor controls, the Contractor will replace them subject to consultation with and approval by the Project Manager.

SC-22 PRESERVATION OF PERMANENT LAND SURVEY CONTROL MARKERS

Hereby Replaces General Contract Condition 319 General Contract Condition 319 PRESERVATION OF PERMANENT LAND SURVEY CONTROL MARKERS is hereby deleted in its entirety and replaced with the following:

Throughout the City there exists an extensive system of benchmarks and monuments installed for the purpose of maintaining a land survey control grid. Prior to the commencement of work on the Project, the Contractor shall tie out each existing survey monument and benchmark so that it can be reestablished after completion of the Work should it be damaged. The Contractor shall maintain all ties during construction. The Contractor shall reset and rehabilitate all survey monuments and benchmarks that existed prior to construction, but that were damaged or destroyed during construction, in accordance with City and State requirements at no cost to the City.

SC-23 USE, POSSESSION OR SALE OF ALCOHOL OR DRUGS. The Contractor, its officers, agents, and employees shall cooperate and comply with the provisions of Executive Order 94 and Attachment A thereto concerning the use, possession or sale of alcohol or drugs. Violation of these provisions or refusal to cooperate with implementation of the policy can result in the City's barring the Contractor from City facilities or participating in City operations.

SC-24 Title 311 NO EMPLOYMENT OF ILLEGAL ALIENS TO PERFORM WORK UNDER THE CONTRACT is hereby deleted in its entirety and replaced with the following:

311 NO EMPLOYMENT OF A WORKER WITHOUT AUTHORIZATION TO PERFORM WORK UNDER THE AGREEMENT

1.1. This Agreement is subject to Division 5 of Article IV of Chapter 20 of the Denver Revised Municipal Code, and any amendments (the "Certification Ordinance").

1.2. The Contractor certifies that:

1.2.1. At the time of its execution of this Agreement, it does not knowingly employ or contract with a worker without authorization who will perform work under this Agreement, nor will it knowingly employ or contract with a worker without authorization to perform work under this Agreement in the future.

1.2.2. It will participate in the E-Verify Program, as defined in § 8-17.5-101(3.7), C.R.S., and confirm the employment eligibility of all employees who are newly hired for employment to perform work under this Agreement.

1.2.3. It will not enter into a contract with a subconsultant or subcontractor that fails to certify to the Contractor that it shall not knowingly employ or contract with a worker without authorization to perform work under this Agreement.

1.2.4. It is prohibited from using the E-Verify Program procedures to undertake pre-employment screening of job applicants while performing its obligations under this Agreement, and it is required to comply with any and all federal requirements related to use of the E-Verify Program including, by way of example, all program requirements related to employee notification and preservation of employee rights.

1.2.5. If it obtains actual knowledge that a subconsultant or subcontractor performing work under this Agreement knowingly employs or contracts with a worker without authorization, it will notify such subconsultant or subcontractor and the City within three (3) days. The Contractor shall also terminate such subconsultant or subcontractor if within three (3) days after such notice the subconsultant or subcontractor does not stop employing or contracting with the worker without authorization, unless during the three-day period the subconsultant or subcontractor provides information to establish that the subconsultant or subcontractor has not knowingly employed or contracted with a worker without authorization.

1.2.6. It will comply with a reasonable request made in the course of an investigation by the Colorado Department of Labor and Employment under authority of § 8-17.5-102(5), C.R.S., or the City Auditor, under authority of D.R.M.C. 20-90.3.

1.3. The Contractor is liable for any violations as provided in the Certification Ordinance. If the Contractor violates any provision of this section or the Certification Ordinance, the City may terminate this Agreement for a breach of the Agreement. If this Agreement is so terminated, the Contractor shall be liable for actual and consequential damages to the City. Any termination of a contract due to a violation of this section or the Certification Ordinance may also, at the discretion of the City, constitute grounds for disqualifying the Contractor from submitting bids or proposals for future contracts with the City.

[REMAINDER OF PAGE INTENTIONALLY LEFT BLANK]

CITY AND COUNTY OF DENVER
DEPARTMENT OF TRANSPORTATION AND INFRASTRUCTURE

Bond Number: 4369929

PERFORMANCE AND PAYMENT BOND

KNOW ALL MEN BY THESE PRESENTS, that we, the undersigned Hamon Infrastructure, Inc.

a corporation organized and existing under and by virtue of the laws of the State of Colorado,
hereafter referred to as the "Contractor", and Great American Insurance Company,
a corporation organized and existing under and by virtue of the laws of the State of Ohio,
and authorized to transact business in the State of Colorado, as Surety, are held and firmly bound unto the CITY
AND COUNTY OF DENVER, a municipal corporation of the State of Colorado, hereinafter referred to as the
"City", in the penal sum of Six Million, Three Hundred Forty Five Thousand, Nine Hundred Ninety Seven and 02/100
Dollars (\$ 6,345,997.02), lawful
money of the United States of America, for the payment of which sum, well and truly to be made, we bind ourselves
and our heirs, executors, administrators, successors and assigns, jointly and severally, firmly by these presents;

THE CONDITION OF THE FOREGOING OBLIGATION IS SUCH THAT:

WHEREAS, the above bounden Contractor has entered into a written contract with the aforesaid City for furnishing
all labor and tools, supplies, equipment, superintendence, materials and everything necessary for and required to
do, perform and complete the construction of **Contract No. 202263315 - Connecting Auraria**, Denver, Colorado,
and has bound itself to complete the project within the time or times specified or pay liquidated damages, all as
designated, defined and described in the said Contract and Conditions thereof, and in accordance with the Plans and
Technical Specifications therefore, a copy of said Contract being made a part hereof;

NOW, THEREFORE, if the said Contractor shall and will, in all particulars well and truly and faithfully observe,
perform and abide by each and every Covenant, Condition and part of said Contract, and the Conditions, Technical
Specifications, Plans, and other Contract Documents thereto attached, or by reference made a part thereof and any
alterations in and additions thereto, according to the true intent and meaning in such case, then this obligation shall
be and become null and void; otherwise, it shall remain in full force and effect;

PROVIDED FURTHER, that if the said Contractor shall satisfy all claims and demands incurred by the Contractor
in the performance of said Contract, and shall fully indemnify and save harmless the City from all damages, claims,
demands, expense and charge of every kind (including claims of patent infringement) arising from any act,
omission, or neglect of said Contractor, its agents, or employees with relation to said work; and shall fully reimburse
and repay to the City all costs, damages, and expenses which it may incur in making good any default based upon
the failure of the Contractor to fulfill its obligation to furnish maintenance, repairs or replacements for the full
guarantee period provided in the Contract Documents, then this obligation shall be null and void; otherwise it shall
remain in full force and effect;

PROVIDED FURTHER, that if said Contractor shall at all times promptly make payments of all amounts lawfully
due to all persons supplying or furnishing it or its subcontractors with labor and materials, rental machinery, tools
or equipment used or performed in the prosecution of work provided for in the above Contract and that if the
Contractor will indemnify and save harmless the City for the extent of any and all payments in connection with the
carrying out of such Contract, then this obligation shall be null and void; otherwise it shall remain in full force and
effect;

PROVIDED FURTHER, that if the said Contractor fails to duly pay for any labor, materials, team hire, sustenance,
provisions, provender, gasoline, lubricating oils, fuel oils, grease, coal, or any other supplies or materials used or
consumed by said Contractor or its subcontractors in performance of the work contracted to be done, or fails to pay
any person who supplies rental machinery, tools or equipment, all amounts due as the result of the use of such
machinery, tools or equipment in the prosecution of the work, the Surety will pay the same in any amount not
exceeding the amount of this obligation, together with interest as provided by law;

Bond Number: 4369929

PROVIDED FURTHER, that the said Surety, for value received, hereby stipulates and agrees that no change, extension of time, alteration or addition to the terms of the Contract, or to contracts with others in connection with this project, or the work to be performed thereunder, or the Technical Specifications and Plans accompanying the same, shall in any way affect its obligation on this bond and it does hereby waive notice of any change, extension of time, alteration or addition to the terms of the Contract, or contracts, or to the work, or to the Technical Specifications and Plans.

IN WITNESS WHEREOF, said Contractor and said Surety have executed these presents as of this 30th day of August, 20 22.

Hamon Infrastructure, Inc.
Contractor

Attest:



Vice - Secretary, Ryan Mastrianni

By: Brad Davis
Vice - President, Brad Davis

Great American Insurance Company
Surety

By: Ashlea McCaughey
Attorney-In-Fact Ashlea McCaughey



(Accompany this bond with Attorney-in-Fact's authority from the Surety to execute bond, certified to include the date of the bond).

APPROVED AS TO FORM:
Attorney for the City and County of Denver

By: [Signature]
Assistant City Attorney

APPROVED FOR THE CITY AND COUNTY OF DENVER

By: [Signature]
MAYOR

By: [Signature]
EXECUTIVE DIRECTOR OF THE DEPARTMENT OF TRANSPORTATION AND INFRASTRUCTURE

GREAT AMERICAN INSURANCE COMPANY®

Administrative Office: 301 E 4TH STREET • CINCINNATI, OHIO 45202 • 513-369-5000 • FAX 513-723-2740

The number of persons authorized by this power of attorney is not more than SIX

No. 0 21481

POWER OF ATTORNEY

KNOW ALL MEN BY THESE PRESENTS: That the GREAT AMERICAN INSURANCE COMPANY, a corporation organized and existing under and by virtue of the laws of the State of Ohio, does hereby nominate, constitute and appoint the person or persons named below, each individually if more than one is named, its true and lawful attorney-in-fact, for it and in its name, place and stead to execute on behalf of the said Company, as surety, any and all bonds, undertakings and contracts of suretyship, or other written obligations in the nature thereof; provided that the liability of the said Company on any such bond, undertaking or contract of suretyship executed under this authority shall not exceed the limit stated below.

| Name | Address | Limit of Power |
|-------------------|-------------------|----------------|
| DONALD E. APPELBY | MARK SWEIGART | ALL |
| TODD D. BENGFORD | ASHLEA MCCAUGHEY | \$100,000,000 |
| SARAH C. BROWN | JESSICA JEAN RINI | |

This Power of Attorney revokes all previous powers issued on behalf of the attorney(s)-in-fact named above.

IN WITNESS WHEREOF the GREAT AMERICAN INSURANCE COMPANY has caused these presents to be signed and attested by its appropriate officers and its corporate seal hereunto affixed this 28TH day of SEPTEMBER, 2020



Atty L C. B.

Assistant Secretary

GREAT AMERICAN INSURANCE COMPANY

Mark V Vicario

Divisional Senior Vice President

STATE OF OHIO, COUNTY OF HAMILTON - ss:

On this 28TH day of SEPTEMBER, 2020

MARK VICARIO (877-377-2405)

before me personally appeared MARK VICARIO, to me known, being duly sworn, deposes and says that he resides in Cincinnati, Ohio, that he is a Divisional Senior Vice President of the Bond Division of Great American Insurance Company, the Company described in and which executed the above instrument; that he knows the seal of the said Company; that the seal affixed to the said instrument is such corporate seal; that it was so affixed by authority of his office under the By-Laws of said Company, and that he signed his name thereto by like authority.



SUSAN A KOHORST
Notary Public
State of Ohio
My Comm. Expires
May 18, 2025

Susan A Kohorst

This Power of Attorney is granted by authority of the following resolutions adopted by the Board of Directors of Great American Insurance Company by unanimous written consent dated June 9, 2008.

RESOLVED: That the Divisional President, the several Divisional Senior Vice Presidents, Divisional Vice Presidents and Divisional Assistant Vice Presidents, or any one of them, be and hereby is authorized, from time to time, to appoint one or more Attorneys-in-Fact to execute on behalf of the Company, as surety, any and all bonds, undertakings and contracts of suretyship, or other written obligations in the nature thereof; to prescribe their respective duties and the respective limits of their authority; and to revoke any such appointment at any time.

RESOLVED FURTHER: That the Company seal and the signature of any of the aforesaid officers and any Secretary or Assistant Secretary of the Company may be affixed by facsimile to any power of attorney or certificate of either given for the execution of any bond, undertaking, contract of suretyship, or other written obligation in the nature thereof, such signature and seal when so used being hereby adopted by the Company as the original signature of such officer and the original seal of the Company, to be valid and binding upon the Company with the same force and effect as though manually affixed.

CERTIFICATION

I, STEPHEN C. BERAHA, Assistant Secretary of Great American Insurance Company, do hereby certify that the foregoing Power of Attorney and the Resolutions of the Board of Directors of June 9, 2008 have not been revoked and are now in full force and effect.

Signed and sealed this

day of

2022



Atty L C. B.

Assistant Secretary



THINKING AHEAD

August 22, 2022

PERFORMANCE AND PAYMENT BOND
SURETY AUTHORIZATION

FAX NUMBER: 720-913-3183
TELEPHONE NUMBER: 720-913-3267

Assistant City Attorney
201 W. Colfax Avenue, Dept. 1207
Denver, Colorado 80202

RE: **Hamon Infrastructure, Inc.**

Contract No: **202263315**
Federal Project No:
Project Name: **Connecting Auraria**
Contract Amount: **\$6,345,997.02**
Performance and Payment Bond No: **4369929**

Dear Assistant City Attorney,

The Performance and Payment Bonds covering the above captioned project were executed by this agency through Great American Insurance Company insurance company, on August 22nd, 2022.

We hereby authorize the City and County of Denver, the Department of Transportation and Infrastructure, to date all bonds and powers of attorney to coincide with the date of the contract.

If you should have any additional questions or concerns, please don't hesitate to give me a call at (720) 622-8245.

Thank you,
Great American Insurance Company
Sincerely,

A handwritten signature in blue ink that reads 'Ashlea M. McCaughey'.

Ashlea McCaughey, Attorney-in-Fact



CERTIFICATE OF LIABILITY INSURANCE

DATE (MM/DD/YYYY)
09/07/2022

THIS CERTIFICATE IS ISSUED AS A MATTER OF INFORMATION ONLY AND CONFERS NO RIGHTS UPON THE CERTIFICATE HOLDER. THIS CERTIFICATE DOES NOT AFFIRMATIVELY OR NEGATIVELY AMEND, EXTEND OR ALTER THE COVERAGE AFFORDED BY THE POLICIES BELOW. THIS CERTIFICATE OF INSURANCE DOES NOT CONSTITUTE A CONTRACT BETWEEN THE ISSUING INSURER(S), AUTHORIZED REPRESENTATIVE OR PRODUCER, AND THE CERTIFICATE HOLDER.

IMPORTANT: If the certificate holder is an ADDITIONAL INSURED, the policy(ies) must have ADDITIONAL INSURED provisions or be endorsed. If SUBROGATION IS WAIVED, subject to the terms and conditions of the policy, certain policies may require an endorsement. A statement on this certificate does not confer rights to the certificate holder in lieu of such endorsement(s).

| PRODUCER 1-844-484-7750 Holmes Murphy & Associates - CO 7600 East Orchard Road, Suite 230 South Greenwood Village, CO 80111 | CONTACT NAME: Colleen Luther PHONE (A/C No. Ext): 720-458-5744 FAX (A/C, No): E-MAIL ADDRESS: CLuther@holmesmurphy.com | | | | | | | | | | | | | | | | | | | | | |
|---|---|-------------------------------|--|--------|---|--|--|-----------------------------------|--|-------|--|--|--|---------------------------|--|-------|---------------------------------|--|-------|--------------------------------------|--|-------|
| INSURED Hamon Infrastructure, Inc. 5670 Franklin Street Denver, CO 80216 | <table border="1" style="width: 100%; border-collapse: collapse;"> <tr> <th colspan="2" style="text-align: center;">INSURER(S) AFFORDING COVERAGE</th> <th style="text-align: center;">NAIC #</th> </tr> <tr> <td colspan="2">INSURER A: Charter Oak Fire Insurance Company</td> <td></td> </tr> <tr> <td colspan="2">INSURER B: TRAVELERS IND CO OF CT</td> <td style="text-align: center;">25682</td> </tr> <tr> <td colspan="2">INSURER C: Travelers Property Casualty Co. America</td> <td></td> </tr> <tr> <td colspan="2">INSURER D: PINNACOL ASSUR</td> <td style="text-align: center;">41190</td> </tr> <tr> <td colspan="2">INSURER E: INDIAN HARBOR INS CO</td> <td style="text-align: center;">36940</td> </tr> <tr> <td colspan="2">INSURER F: ATLANTIC SPECIALTY INS CO</td> <td style="text-align: center;">27154</td> </tr> </table> | INSURER(S) AFFORDING COVERAGE | | NAIC # | INSURER A: Charter Oak Fire Insurance Company | | | INSURER B: TRAVELERS IND CO OF CT | | 25682 | INSURER C: Travelers Property Casualty Co. America | | | INSURER D: PINNACOL ASSUR | | 41190 | INSURER E: INDIAN HARBOR INS CO | | 36940 | INSURER F: ATLANTIC SPECIALTY INS CO | | 27154 |
| INSURER(S) AFFORDING COVERAGE | | NAIC # | | | | | | | | | | | | | | | | | | | | |
| INSURER A: Charter Oak Fire Insurance Company | | | | | | | | | | | | | | | | | | | | | | |
| INSURER B: TRAVELERS IND CO OF CT | | 25682 | | | | | | | | | | | | | | | | | | | | |
| INSURER C: Travelers Property Casualty Co. America | | | | | | | | | | | | | | | | | | | | | | |
| INSURER D: PINNACOL ASSUR | | 41190 | | | | | | | | | | | | | | | | | | | | |
| INSURER E: INDIAN HARBOR INS CO | | 36940 | | | | | | | | | | | | | | | | | | | | |
| INSURER F: ATLANTIC SPECIALTY INS CO | | 27154 | | | | | | | | | | | | | | | | | | | | |

COVERAGES **CERTIFICATE NUMBER: 66513950** **REVISION NUMBER:**

THIS IS TO CERTIFY THAT THE POLICIES OF INSURANCE LISTED BELOW HAVE BEEN ISSUED TO THE INSURED NAMED ABOVE FOR THE POLICY PERIOD INDICATED. NOTWITHSTANDING ANY REQUIREMENT, TERM OR CONDITION OF ANY CONTRACT OR OTHER DOCUMENT WITH RESPECT TO WHICH THIS CERTIFICATE MAY BE ISSUED OR MAY PERTAIN, THE INSURANCE AFFORDED BY THE POLICIES DESCRIBED HEREIN IS SUBJECT TO ALL THE TERMS, EXCLUSIONS AND CONDITIONS OF SUCH POLICIES. LIMITS SHOWN MAY HAVE BEEN REDUCED BY PAID CLAIMS.

| INSR LTR | TYPE OF INSURANCE | ADDL INSD | SUBR WVD | POLICY NUMBER | POLICY EFF (MM/DD/YYYY) | POLICY EXP (MM/DD/YYYY) | LIMITS |
|----------|---|--|----------|-------------------|-------------------------|-------------------------|---|
| A | <input checked="" type="checkbox"/> COMMERCIAL GENERAL LIABILITY <input type="checkbox"/> CLAIMS-MADE <input checked="" type="checkbox"/> OCCUR <input checked="" type="checkbox"/> PD Ded: \$2,500 GEN'L AGGREGATE LIMIT APPLIES PER: <input type="checkbox"/> POLICY <input checked="" type="checkbox"/> PRO-JECT <input type="checkbox"/> LOC OTHER: | | | DTCO3C223967COF21 | 12/31/21 | 12/31/22 | EACH OCCURRENCE \$ 1,000,000 DAMAGE TO RENTED PREMISES (Ea occurrence) \$ 300,000 MED EXP (Any one person) \$ 10,000 PERSONAL & ADV INJURY \$ 1,000,000 GENERAL AGGREGATE \$ 2,000,000 PRODUCTS - COMP/OP AGG \$ 2,000,000 \$ |
| B | <input checked="" type="checkbox"/> AUTOMOBILE LIABILITY <input checked="" type="checkbox"/> ANY AUTO <input type="checkbox"/> OWNED AUTOS ONLY <input type="checkbox"/> SCHEDULED AUTOS <input checked="" type="checkbox"/> HIRED AUTOS ONLY <input checked="" type="checkbox"/> NON-OWNED AUTOS ONLY | | | 8101L5560112126G | 12/31/21 | 12/31/22 | COMBINED SINGLE LIMIT (Ea accident) \$ 1,000,000 BODILY INJURY (Per person) \$ BODILY INJURY (Per accident) \$ PROPERTY DAMAGE (Per accident) \$ \$ |
| C | <input checked="" type="checkbox"/> UMBRELLA LIAB <input checked="" type="checkbox"/> OCCUR <input type="checkbox"/> EXCESS LIAB <input type="checkbox"/> CLAIMS-MADE <input type="checkbox"/> DED <input checked="" type="checkbox"/> RETENTION \$ 10,000 | | | CUP3K0775952126 | 12/31/21 | 12/31/22 | EACH OCCURRENCE \$ 10,000,000 AGGREGATE \$ 10,000,000 \$ |
| D | WORKERS COMPENSATION AND EMPLOYERS' LIABILITY ANY PROPRIETOR/PARTNER/EXECUTIVE OFFICER/MEMBER EXCLUDED? (Mandatory in NH) If yes, describe under DESCRIPTION OF OPERATIONS below | Y/N <input checked="" type="checkbox"/> N | N/A | 4204960 | 10/01/22 | 10/01/23 | <input checked="" type="checkbox"/> PER STATUTE <input type="checkbox"/> OTH-ER E.L. EACH ACCIDENT \$ 1,000,000 E.L. DISEASE - EA EMPLOYEE \$ 1,000,000 E.L. DISEASE - POLICY LIMIT \$ 1,000,000 |
| E | Pollution Liability | | | PEC004883205 | 12/31/21 | 12/31/22 | \$5,000,000 Limit 25,000Ded |
| F | Installation Floater | | | 7100398310001 | 12/31/21 | 12/31/22 | \$6,500,000 2,500Ded |
| F | Installation Floater | | | 7100398310001 | 12/31/21 | 12/31/22 | \$6,500,000 Limit 2,500Ded |

DESCRIPTION OF OPERATIONS / LOCATIONS / VEHICLES (ACORD 101, Additional Remarks Schedule, may be attached if more space is required)

Project: Connecting Auraria
 Project Number: 202263315

As required by written contract or written agreement, the City and County of Denver, its elected and appointed officers, employees and volunteers are included as Additional Insured under General Liability and Automobile Liability with respect to the above referenced.

CERTIFICATE HOLDER

CANCELLATION

| | |
|--|---|
| City and County of Denver Department of Transportation & Infrastructure 201 Colfax Avenue, Department 608 Denver, CO 80202 USA | SHOULD ANY OF THE ABOVE DESCRIBED POLICIES BE CANCELLED BEFORE THE EXPIRATION DATE THEREOF, NOTICE WILL BE DELIVERED IN ACCORDANCE WITH THE POLICY PROVISIONS. AUTHORIZED REPRESENTATIVE |
|--|---|



PERFORMANCE AND PAYMENT BOND SURETY AUTHORIZATION (SAMPLE)

FAX NUMBER: 720-913-XXXX
TELEPHONE NUMBER: 720-913-XXXX

Assistant City Attorney
201 W. Colfax Ave. Dept 1207
Denver, Colorado 80202

RE: (Company name)

Contract No: **202263315**
Project Name: **Connecting Auraria**
Contract Amount: **\$6,345,997.02**

Performance and Payment Bond No.:

Dear Assistant City Attorney,

The Performance and Payment Bonds covering the above captioned project were executed by this agency, through _____ insurance company, on _____, 20__.

We hereby authorize the City and County of Denver, the Department of Transportation and Infrastructure, to date all bonds and powers of attorney to coincide with the date of the contract.

If you should have any additional questions or concerns, please don't hesitate to give me a call at _____ and/or email _____.

Thank you.

Sincerely,

City and County of Denver Department of Transportation & Infrastructure
201 West Colfax Avenue, Dept 608 | Denver, CO 80202
www.denvergov.org/doti

311 | POCKETGOV.COM | DENVERGOV.ORG | DENVER 8 TV



NOTICE TO APPARENT LOW BIDDER (SAMPLE)

Name
Address
City, State Zip

The EXECUTIVE DIRECTOR OF THE DEPARTMENT OF TRANSPORTATION AND INFRASTRUCTURE has considered the Bids submitted on **July 14, 2022**, for work to be done and materials to be furnished in and for:

CONTRACT 202263315 - Connecting Auraria

as set forth in detail in the Contract Documents for the City and County of Denver, Colorado. It appears that your Bid is fair, equitable, and to the best interest of the City and County; therefore, said Bid is hereby accepted at the bid price contained herein, subject to the approval and execution of the Contract Documents by the City in accordance with the Charter of the City and County of Denver, and to your furnishing the items specified below. The award is based on the total bid items: **(One Hundred Seventy-Five (175) base bid items (201-00001 through LS2)** the total estimated cost thereof being: **(Six Million Three Hundred Forty-Five Thousand Nine Hundred and Ninety-Seven Dollars and Two Cents (\$6,345,997.02)).**

In accordance with the requirements set forth in the Contract Documents, you are required to furnish the following documents:

- a. Insurance Certificates: Commercial General Liability, Business Automobile Liability, Workman's Compensation and Employer Liability, Builder's Risk or Installation Floater and Professional Liability (Errors & Omissions); and
- b. Payment and Performance Bond along with One original Power of Attorney relative to Performance and/or Payment Bond.

All construction contracts made and entered into by the City and County of Denver are subject to Affirmative Action and Equal Opportunity Rules and Regulations, as adopted by the Manager of the Department of Transportation and Infrastructure, and each contract requiring payment by the City of one-half million dollars (\$500,000.00) or more shall first be approved by the City Council acting by ordinance or resolution and in accordance with Section 3.2.6 of the Charter of the City and County of Denver.

The Bid Security submitted with your Bid will be returned upon execution of the Contract and furnishing of the Performance Bond. In the event you should fail to furnish the Performance Bond or execute the contract within the time limit specified, said Bid Security will be retained by the City and County of Denver as liquidated damages, and not as a penalty for the delay and extra work caused thereby.

NOTICE TO APPARENT LOW BIDDER

CONTRACT NO. 202263315

Page 2

Dated at Denver, Colorado this _____ day of _____ 20__.

CITY AND COUNTY OF DENVER

By _____
Executive Director
Department of Transportation and Infrastructure

SAMPLE

City and County of Denver Department of Transportation & Infrastructure
201 West Colfax Avenue, Dept 608 | Denver, CO 80202
www.denvergov.org/doti

311 | POCKETGOV.COM | DENVERGOV.ORG | DENVER 8 TV



NOTICE TO PROCEED (SAMPLE)

Current Date

Name
Company
Street
City/State/Zip

CONTRACT NO. 202263315 - Connecting Auraria

In accordance with General Contract Condition 302 of the Standard Specifications for Construction, General Contract Conditions, 2011 Edition, you are hereby authorized and directed to proceed on _____ with the work of constructing contract number 202263315, as set forth in detail in the contract documents for the City and County of Denver.

With a contract time of 300 calendar days, the project must be complete on or before _____.

If you have not already done so, you must submit your construction schedule, in accordance with General Contract Condition 306.2.B, to the Project Manager within 10 days. Additionally, you must submit your tax-exempt certificate, and copies of your subcontractors' certificates, in accordance with General Contract Condition 323.5, to the Project Manager as soon as possible. Failure to submit these certificates will delay processing of payment applications.

Sincerely,

By: _____
City Engineer

cc:

City and County of Denver Department of Transportation & Infrastructure
201 West Colfax Avenue, Dept 608 | Denver, CO 80202
www.denvergov.org/doti

311 | POCKETGOV.COM | DENVERGOV.ORG | DENVER 8 TV



CERTIFICATE OF CONTRACT RELEASE (SAMPLE)
202263315 - Connecting Auraria

Current Date
Name
Street Address
City, State, Zip

Upon receipt of the below stated amount from the City and County of Denver, as full and final payment of the cost of the improvements provided for in the foregoing contract, _____dollars and _____ cents (\$ _____), in cash, being the remainder of the full amount accruing to the undersigned by virtue of said contract; said cash also covering and including full payment for the cost of all work, extra work and material furnished by the undersigned in the construction of said improvements, and all incidentals thereto, and the undersigned hereby releases said City and County of Denver from any and all claims or demands whatsoever, regardless of how denominated, growing out of said contract.

The Undersigned further certifies that each of the undersigned's subcontractors and suppliers that incurred or caused to be incurred, on their behalf, costs, charges or expenses in connection with the undersigned's Work effort on the above referenced Project have been duly paid in full. The undersigned further agrees to defend, indemnify and save and hold harmless the City, its officers, employees, agents and assigns and the above-referenced Contractor from and against all costs, losses, damages, causes of action, judgments under the subcontract and expenses arising out of or in connection with any claim or claims against the City or the Contractor which arise out of the Undersigned's performance of the Work effort and which may be asserted by the Undersigned or any of its suppliers or subcontractors of any tier or any of their representatives, officers, agents, or employees.

And these presents are to certify that all persons performing work upon or furnishing materials for said improvements under the foregoing contract have been paid in full and this payment to be made as described herein is the last or final payment.

Contractor's Signature Date Signed

If there are any questions, please contact me by telephone at (###) ###-####. Please return this document to me via email at doti.procurement@denvergov.org.

Sincerely,

Contract Administration

City and County of Denver Department of Transportation & Infrastructure
201 West Colfax Avenue, Dept 608 | Denver, CO 80202
www.denvergov.org/doti

311 | POCKETGOV.COM | DENVERGOV.ORG | DENVER 8 TV

**DEPARTMENT OF TRANSPORTATION AND INFRASTRUCTURE
FINAL/PARTIAL RELEASE AND CERTIFICATE OF PAYMENT (SAMPLE)
(PRIME CONTRACTOR)**

(PROJECT NO. and NAME)

Date: _____, 20__.

(NAME OF OWNER)

Contract #: _____.

(NAME OF PRIME CONTRACTOR)

Contract Value: \$ _____.

Current Progress Payment: \$ _____.

Date: _____.

Total Paid to Date: \$ _____.

Date of Last Work: _____.

The Undersigned hereby certifies that all costs, charges or expenses incurred by the undersigned or on behalf of the undersigned for any work, labor or services performed and for any materials, supplies or equipment provided on the above referenced Project or used in connection with the above referenced Subcontract (the "Work Effort") have been duly paid in full.

The Undersigned further certifies that each of the undersigned's subcontractors and suppliers that incurred or caused to be incurred, on their behalf, costs, charges or expenses in connection with the undersigned's Work Effort on the above referenced Project have been duly paid in full.

In consideration of \$ _____ representing the Current Progress Payment referenced above and in further consideration of the Total Paid to Date, also referenced above, and other good and valuable consideration received and accepted by the undersigned this ____ day of _____, 20__, the Undersigned hereby releases and discharges the City and County of Denver (the "City"), the above referenced City Project, the City's premises and property and the above referenced Contractor from all claims, liens, rights, liabilities, demands and obligations, whether known or unknown, of every nature arising out of or in connection with the performance of the work effort.

As additional consideration for the payments referenced above, the undersigned agrees to defend, indemnify and save and hold harmless the City, its officers, employees, agents and assigns and the above-referenced Contractor from and against all costs, losses, damages, causes of action, judgments under the subcontract and expenses arising out of or in connection with any claim or claims against the City or the Contractor which arise out of the Undersigned's performance of the Work Effort and which may be asserted by the Undersigned or any of its suppliers or subcontractors of any tier or any of their representatives, officers, agents, or employees.

It is acknowledged that this release is for the benefit of and may be relied upon by the City and the referenced Contractor.

The foregoing shall not relieve the undersigned of any obligation under the provisions of the Undersigned's subcontract, as the subcontract may have been amended, which by their nature survive completion of the Undersigned's work effort including, without limitation, warranties, guarantees, insurance requirements and indemnities.

(Name of Contractor)

By: _____

Title: _____

CITY AND COUNTY OF DENVER
STATE OF COLORADO



DENVER
THE MILE HIGH CITY

**DEPARTMENT OF TRANSPORTATION &
INFRASTRUCTURE**

Prevailing Wage Rates

Contract Number: 202263315

Connecting Auraria

June 6, 2022



TO: All Users of the City and County of Denver Prevailing Wage Schedules
FROM: Ryland Feno, Classification and Compensation Analyst Staff
DATE: February 28, 2022
SUBJECT: Latest Change to Prevailing Wage Schedules

The effective date for this publication will be **Friday, February 25, 2022** and applies to the City and County of Denver for **HEAVY CONSTRUCTION PROJECTS** in accordance with the Denver Revised Municipal Code, Section 20-76(c).

General Wage Decision No. CO20220002
Superseded General Decision No. CO20210002
Modification No. 3
Publication Date: 02/25/2022
(6 pages)

Unless otherwise specified in this document, apprentices shall be permitted only if they are employed pursuant to and individually registered in a bona fide apprenticeship program registered with the U.S. Department of Labor (DOL). The employer and the individual apprentice must be registered in a program which has received prior approval by the DOL. Any employer who employs an apprentice and is found to be in violation of this provision shall be required to pay said apprentice the full journeyman scale.

Attachments as listed above.

***Career Service Board approved to adjust all Davis Bacon classifications under \$15.87 to comply with the city's minimum wage. The effective date is January 1, 2022. See page 8 for reference.**

Office of Human Resources
201 W. Colfax Ave. Dept. 412 | Denver, CO 80202
p: 720.913.5751 | f: 720.913.5720
www.denvergov.org/humanresources

"General Decision Number: CO20220002 02/25/2022

Superseded General Decision Number: CO20210002

State: Colorado

Construction Type: Heavy

Counties: Adams, Arapahoe, Boulder, Broomfield, Denver, Douglas, El Paso, Jefferson, Larimer, Mesa, Pueblo and Weld Counties in Colorado.

HEAVY CONSTRUCTION PROJECTS

Note: Contracts subject to the Davis-Bacon Act are generally required to pay at least the applicable minimum wage rate required under Executive Order 14026 or Executive Order 13658. Please note that these Executive Orders apply to covered contracts entered into by the federal government that are subject to the Davis-Bacon Act itself, but do not apply to contracts subject only to the Davis-Bacon Related Acts, including those set forth at 29 CFR 5.1(a)(2)-(60).

| | |
|---|--|
| If the contract is entered into on or after January 30, 2022, or the contract is renewed or extended (e.g., an option is exercised) on or after January 30, 2022: | . Executive Order 14026 generally applies to the contract. . The contractor must pay all covered workers at least \$15.00 per hour (or the applicable wage rate listed on this wage determination, if it is higher) for all hours spent performing on the contract in 2022. |
| If the contract was awarded on or between January 1, 2015 and January 29, 2022, and the contract is not renewed or extended on or after January 30, 2022: | . Executive Order 13658 generally applies to the contract. . The contractor must pay all covered workers at least \$11.25 per hour (or the applicable wage rate listed on this wage determination, if it is higher) for all hours spent performing on that contract in 2022. |

The applicable Executive Order minimum wage rate will be

adjusted annually. If this contract is covered by one of the Executive Orders and a classification considered necessary for performance of work on the contract does not appear on this wage determination, the contractor must still submit a conformance request.

Additional information on contractor requirements and worker protections under the Executive Orders is available at <https://www.dol.gov/agencies/whd/government-contracts>.

| Modification Number | Publication Date |
|---------------------|------------------|
| 0 | 01/07/2022 |
| 1 | 01/28/2022 |
| 2 | 02/18/2022 |
| 3 | 02/25/2022 |

ASBE0028-001 07/01/2019

| | Rates | Fringes |
|--|----------|---------|
| Asbestos Workers/Insulator (Includes application of all insulating materials, protective coverings, coatings and finishings to all types of mechanical systems)..... | \$ 32.98 | 14.73 |

BRCO0007-004 01/01/2021

ADAMS, ARAPAHOE, BOULDER, BROOMFIELD, DENVER, DOUGLAS,
JEFFERSON AND WELD COUNTIES

| | Rates | Fringes |
|-----------------|----------|---------|
| BRICKLAYER..... | \$ 31.43 | 9.72 |

BRCO0007-006 05/01/2018

EL PASO AND PUEBLO COUNTIES

| | Rates | Fringes |
|-----------------|----------|---------|
| BRICKLAYER..... | \$ 25.88 | 10.34 |

ELEC0012-004 09/01/2021

PUEBLO COUNTY

| Rates | Fringes |
|-------|---------|
|-------|---------|

ELECTRICIAN

| | | |
|---------------------------|----------|----------|
| Electrical contract over | | |
| \$1,000,000..... | \$ 29.80 | 13.00+3% |
| Electrical contract under | | |
| \$1,000,000..... | \$ 24.85 | 13.00+3% |

 ELEC0068-001 06/01/2021

ADAMS, ARAPAHOE, BOULDER, BROOMFIELD, DENVER, DOUGLAS,
 JEFFERSON, LARIMER, AND WELD COUNTIES

| | Rates | Fringes |
|------------------|----------|---------|
| ELECTRICIAN..... | \$ 39.75 | 17.27 |

 ELEC0111-001 09/01/2021

| | Rates | Fringes |
|------------------------------|----------|---------------|
| Line Construction: | | |
| Groundman..... | \$ 23.14 | 24.25%+\$7.05 |
| Line Equipment Operator..... | \$ 37.39 | 24.25%+\$7.05 |
| Lineman and Welder..... | \$ 51.92 | 24.25%+\$7.05 |

 ELEC0113-002 06/01/2021

EL PASO COUNTY

| | Rates | Fringes |
|------------------|----------|---------|
| ELECTRICIAN..... | \$ 34.15 | 16.87 |

 ELEC0969-002 06/01/2019

MESA COUNTY

| | Rates | Fringes |
|------------------|----------|---------|
| ELECTRICIAN..... | \$ 25.20 | 10.06 |

 ENGI0009-001 05/01/2021

| | Rates | Fringes |
|-----------------------------|----------|---------|
| Power equipment operators: | | |
| Blade: Finish..... | \$ 31.37 | 12.35 |
| Blade: Rough..... | \$ 31.05 | 12.35 |
| Bulldozer..... | \$ 31.05 | 12.35 |
| Cranes: 50 tons and under.. | \$ 31.70 | 12.35 |
| Cranes: 51 to 90 tons..... | \$ 31.97 | 12.35 |

| | | |
|---|----------|-------|
| Cranes: 91 to 140 tons..... | \$ 33.05 | 12.35 |
| Cranes: 141 tons and over... | \$ 35.17 | 12.35 |
| Forklift..... | \$ 30.67 | 12.35 |
| Mechanic..... | \$ 31.20 | 12.35 |
| Oiler..... | \$ 30.29 | 12.35 |
| Scraper: Single bowl under 40 cubic yards..... | \$ 31.20 | 12.35 |
| Scraper: Single bowl, including pups 40 cubic yards and over and tandem bowls..... | \$ 31.37 | 12.35 |
| Trackhoe..... | \$ 31.20 | 12.35 |

IRON0024-003 12/01/2021

| | Rates | Fringes |
|-----------------------------|----------|---------|
| IRONWORKER, STRUCTURAL..... | \$ 31.00 | 24.59 |
| Structural | | |

LABO0086-001 05/01/2009

| | Rates | Fringes |
|----------------|----------|---------|
| Laborers: | | |
| Pipelayer..... | \$ 18.68 | 6.78 |

PLUM0003-005 06/01/2020

ADAMS, ARAPAHOE, BOULDER, BROOMFIELD, DENVER, DOUGLAS,
JEFFERSON, LARIMER AND WELD COUNTIES

| | Rates | Fringes |
|--------------|----------|---------|
| PLUMBER..... | \$ 43.63 | 16.67 |

PLUM0058-002 07/01/2021

EL PASO COUNTY

| | Rates | Fringes |
|-------------------------------|----------|---------|
| Plumbers and Pipefitters..... | \$ 40.35 | 16.25 |

PLUM0058-008 07/01/2021

PUEBLO COUNTY

| | Rates | Fringes |
|-------------------------------|----------|---------|
| Plumbers and Pipefitters..... | \$ 40.35 | 16.25 |

 PLUM0145-002 07/01/2016

MESA COUNTY

| | Rates | Fringes |
|-------------------------------|----------|---------|
| Plumbers and Pipefitters..... | \$ 35.17 | 11.70 |

 PLUM0208-004 01/01/2021

ADAMS, ARAPAHOE, BOULDER, BROOMFIELD, DENVER, DOUGLAS,
 JEFFERSON, LARIMER AND WELD COUNTIES

| | Rates | Fringes |
|-----------------|----------|---------|
| PIPEFITTER..... | \$ 39.10 | 13.77 |

 SHEE0009-002 07/01/2021

| | Rates | Fringes |
|-------------------------|----------|---------|
| Sheet metal worker..... | \$ 36.45 | 20.15 |

 TEAM0455-002 07/01/2020

| | Rates | Fringes |
|----------------------------|----------|---------|
| Truck drivers: | | |
| Pickup..... | \$ 22.66 | 4.42 |
| Tandem/Semi and Water..... | \$ 23.29 | 4.42 |

 * SUCO2001-006 12/20/2001

| | Rates | Fringes |
|-----------------------------------|-------------|---------|
| BOILERMAKER..... | \$ 17.60 | |
| Carpenters: | | |
| Form Building and Setting... | \$ 16.97 | 2.74 |
| All Other Work..... | \$ 15.14 | 3.37 |
| Cement Mason/Concrete Finisher... | \$ 17.31 | 2.85 |
| IRONWORKER, REINFORCING..... | \$ 18.83 | 3.90 |
| Laborers: | | |
| Common..... | \$ 11.22 ** | 2.92 |
| Flagger..... | \$ 8.91 ** | 3.80 |
| Landscape..... | \$ 12.56 ** | 3.21 |

Painters:

| | | |
|----------------------------|----------|------|
| Brush, Roller & Spray..... | \$ 15.81 | 3.26 |
|----------------------------|----------|------|

Power equipment operators:

| | | |
|-----------------------|----------|------|
| Backhoe..... | \$ 16.36 | 2.48 |
| Front End Loader..... | \$ 17.24 | 3.23 |
| Skid Loader..... | \$ 15.37 | 4.41 |

WELDERS - Receive rate prescribed for craft performing
operation to which welding is incidental.

=====

**Office of Human Resources
Supplemental Rates
(Specific to the Denver Projects)
(Supp #74, Revised: 01-01-2022)**

| Classification | | Base | Fringe |
|---|----------------------------------|-------------|---------------|
| Ironworker | Ornamental | \$24.80 | \$10.03 |
| Laborer | Group 1 | \$18.18 | \$8.27 |
| | Group 2 | \$21.59 | \$8.61 |
| Laborer (Common) | | \$15.87 | \$2.92 |
| Laborer (Flagger) | | \$15.87 | \$3.80 |
| Laborer (Landscape) | | \$15.87 | \$3.21 |
| Laborer (Janitor) | Janitor/Yardmen | \$17.68 | \$8.22 |
| Laborer (Asbestos) | Removal of Asbestos | \$21.03 | \$8.55 |
| Laborer (Tunnel) | Group 1 | \$18.53 | \$8.30 |
| | Group 2 | \$18.63 | \$8.31 |
| | Group 3 | \$19.73 | \$8.42 |
| | Group 4 | \$21.59 | \$8.61 |
| | Group 5 | \$19.68 | \$8.42 |
| Line Construction | Lineman, Gas Fitter/Welder | \$36.88 | \$9.55 |
| | Line Eq Operator/Line Truck Crew | \$25.74 | \$8.09 |
| Millwright | | \$28.00 | \$10.00 |
| Power Equipment Operator | Group 1 | \$22.97 | \$10.60 |
| | Group 2 | \$23.32 | \$10.63 |
| | Group 3 | \$23.67 | \$10.67 |
| | Group 4 | \$23.82 | \$10.68 |
| | Group 5 | \$23.97 | \$10.70 |
| | Group 6 | \$24.12 | \$10.71 |
| | Group 7 | \$24.88 | \$10.79 |
| Power Equipment Operator (Tunnels above and below ground, shafts and raises): | Group 1 | \$25.12 | \$10.81 |
| | Group 2 | \$25.47 | \$10.85 |
| | Group 3 | \$25.57 | \$10.86 |
| | Group 4 | \$25.82 | \$10.88 |
| | Group 5 | \$25.97 | \$10.90 |
| | Group 6 | \$26.12 | \$10.91 |
| | Group 7 | \$26.37 | \$10.94 |
| Truck Driver | Group 1 | \$18.42 | \$10.00 |
| | Group 2 | \$19.14 | \$10.07 |
| | Group 3 | \$19.48 | \$10.11 |
| | Group 4 | \$20.01 | \$10.16 |
| | Group 5 | \$20.66 | \$10.23 |
| | Group 6 | \$21.46 | \$10.31 |

Go to <http://www.denvergov.org/Auditor> to view the Prevailing Wage Clarification Document for a list of complete classifications used.



DOTI-202263315

TO: All Users of the City and County of Denver Prevailing Wage Schedules
FROM: Ryland Feno, Classification and Compensation Analyst Staff
DATE: February 28, 2022
SUBJECT: Latest Change to Prevailing Wage Schedules

Please be advised prevailing wage rates for some building, heavy, highway, and residential construction trades have not been updated by the United States Department of Labor (DOL) since March 1, 2002. The Career Service Board, in their meeting held on April 21, 2011, approved the use of the attached supplemental wage rates until prevailing wage rates for these classifications of work are again published by the United States Department of Labor in accordance with the Davis-Bacon Act.

The effective date for this publication will be **Friday, February 25, 2022** and applies to the City and County of Denver for **HIGHWAY CONSTRUCTION PROJECTS** in accordance with the Denver Revised Municipal Code, Section 20-76(c).

General Wage Decision No. CO20220009
Superseded General Decision No. CO20210009
Modification No. 1
Publication Date: 02/25/2022
(6 pages)

Unless otherwise specified in this document, apprentices shall be permitted only if they are employed pursuant to and individually registered in a bona fide apprenticeship program registered with the U.S. Department of Labor (DOL). The employer and the individual apprentice must be registered in a program which has received prior approval by the DOL. Any employer who employs an apprentice and is found to be in violation of this provision shall be required to pay said apprentice the full journeyman scale.

Attachments as listed above.

***Career Service Board approved to adjust all Davis Bacon classifications under \$15.87 to comply with the city's minimum wage. The effective date is January 1, 2022. See page 7 for reference.**

Office of Human Resources
201 W. Colfax Ave. Dept. 412 | Denver, CO 80202
p: 720.913.5751 | f: 720.913.5720
www.denvergov.org/humanresources

"General Decision Number: CO20220009 02/25/2022

Superseded General Decision Number: CO20210009

State: Colorado

Construction Type: Highway

Counties: Denver and Douglas Counties in Colorado.

HIGHWAY CONSTRUCTION PROJECTS

Note: Contracts subject to the Davis-Bacon Act are generally required to pay at least the applicable minimum wage rate required under Executive Order 14026 or Executive Order 13658. Please note that these Executive Orders apply to covered contracts entered into by the federal government that are subject to the Davis-Bacon Act itself, but do not apply to contracts subject only to the Davis-Bacon Related Acts, including those set forth at 29 CFR 5.1(a)(2)-(60).

| | |
|---|---|
| <p> If the contract is entered into on or after January 30, 2022, or the contract is renewed or extended (e.g., an option is exercised) on or after January 30, 2022:</p> | <p> . Executive Order 14026 generally applies to the contract. . The contractor must pay all covered workers at least \$15.00 per hour (or the applicable wage rate listed on this wage determination, if it is higher) for all hours spent performing on the contract in 2022.</p> |
| <p> If the contract was awarded on or between January 1, 2015 and January 29, 2022, and the contract is not renewed or extended on or after January 30, 2022:</p> | <p> . Executive Order 13658 generally applies to the contract. . The contractor must pay all covered workers at least \$11.25 per hour (or the applicable wage rate listed on this wage determination, if it is higher) for all hours spent performing on that contract in 2022.</p> |

The applicable Executive Order minimum wage rate will be adjusted annually. If this contract is covered by one of the Executive Orders and a classification considered necessary for performance of work on the contract does not appear on this

wage determination, the contractor must still submit a conformance request.

Additional information on contractor requirements and worker protections under the Executive Orders is available at <https://www.dol.gov/agencies/whd/government-contracts>.

| | |
|---------------------|------------------|
| Modification Number | Publication Date |
| 0 | 01/07/2022 |
| 1 | 02/25/2022 |

CARP9901-008 11/01/2019

| | Rates | Fringes |
|---------------------------------|----------|---------|
| CARPENTER (Form Work Only)..... | \$ 26.50 | 10.32 |

ELEC0068-016 03/01/2011

| | Rates | Fringes |
|-----------------------------|----------|------------|
| TRAFFIC SIGNALIZATION: | | |
| Traffic Signal Installation | | |
| Zone 1..... | \$ 26.42 | 4.75%+8.68 |
| Zone 2..... | \$ 29.42 | 4.75%+8.68 |

TRAFFIC SIGNAL INSTALLER ZONE DEFINITIONS

Zone 1 shall be a 35 mile radius, measured from the following addresses in each of the following cities:
 Colorado Springs - Nevada & Bijou
 Denver - Ellsworth Avenue & Broadway
 Ft. Collins - Prospect & College
 Grand Junction - 12th & North Avenue
 Pueblo - I-25 & Highway 50
 All work outside of these areas shall be paid Zone 2 rates.

 ENGI0009-008 05/01/2021

| | Rates | Fringes |
|--|-------|---------|
| POWER EQUIPMENT OPERATOR: | | |
| (3)-Hydraulic Backhoe (Wheel Mounted, under 3/4 yds), Hydraulic Backhoe (Backhoe/Loader combination), Drill Rig Caisson (smaller than Watson 2500 and similar), Loader (up to and | | |

| | |
|--|-------|
| including 6 cu. yd.).....\$ 31.05 | 12.35 |
| (3)-Loader (under 6 cu. yd.) | |
| Denver County.....\$ 31.05 | 12.35 |
| (3)-Motor Grader (blade-rough) | |
| Douglas County.....\$ 31.05 | 12.35 |
| (4)-Crane (50 tons and under), Scraper (single bowl, under 40 cu. yd).....\$ 31.70 | 12.35 |
| (4)-Loader (over 6 cu. yd) | |
| Denver County.....\$ 31.20 | 12.35 |
| (5)-Drill Rig Caisson (Watson 2500 similar or larger), Crane (51-90 tons), Scraper (40 cu.yd and over),.....\$ 31.37 | 12.35 |
| (5)-Motor Grader (blade-finish) | |
| Douglas County.....\$ 31.37 | 12.35 |
| (6)-Crane (91-140 tons).....\$ 33.05 | 12.35 |

 * SUCO2011-004 09/15/2011

| | Rates | Fringes |
|--|-------------|---------|
| CARPENTER (Excludes Form Work)... | \$ 19.27 | 5.08 |
| CEMENT MASON/CONCRETE FINISHER | | |
| Denver..... | \$ 20.18 | 5.75 |
| Douglas..... | \$ 18.75 | 3.00 |
| ELECTRICIAN (Excludes Traffic Signal Installation)..... | \$ 35.13 | 6.83 |
| FENCE ERECTOR (Excludes Link/Cyclone Fence Erection)..... | \$ 13.02 ** | 3.20 |
| GUARDRAIL INSTALLER..... | \$ 12.89 ** | 3.20 |
| HIGHWAY/PARKING LOT STRIPING:Painter | | |
| Denver..... | \$ 12.62 ** | 3.21 |
| Douglas..... | \$ 13.89 ** | 3.21 |
| IRONWORKER, REINFORCING (Excludes Guardrail Installation)..... | \$ 16.69 | 5.45 |
| IRONWORKER, STRUCTURAL (Includes Link/Cyclone Fence Erection, Excludes Guardrail | | |

| | | |
|--|-------------|------|
| Installation)..... | \$ 18.22 | 6.01 |
| LABORER | | |
| Asphalt Raker..... | \$ 16.29 | 4.25 |
| Asphalt Shoveler..... | \$ 21.21 | 4.25 |
| Asphalt Spreader..... | \$ 18.58 | 4.65 |
| Common or General | | |
| Denver..... | \$ 16.76 | 6.77 |
| Douglas..... | \$ 16.29 | 4.25 |
| Concrete Saw (Hand Held).... | \$ 16.29 | 6.14 |
| Landscape and Irrigation.... | \$ 12.26 ** | 3.16 |
| Mason Tender- | | |
| Cement/Concrete | | |
| Denver..... | \$ 16.96 | 4.04 |
| Douglas..... | \$ 16.29 | 4.25 |
| Pipelayer | | |
| Denver..... | \$ 13.55 ** | 2.41 |
| Douglas..... | \$ 16.30 | 2.18 |
| Traffic Control (Flagger).... | \$ 9.55 ** | 3.05 |
| Traffic Control (Sets Up/Moves Barrels, Cones, Install Signs, Arrow Boards and Place Stationary Flags) (Excludes Flaggers)..... | | |
| | \$ 12.43 ** | 3.22 |
| PAINTER (Spray Only)..... | \$ 16.99 | 2.87 |
| POWER EQUIPMENT OPERATOR: | | |
| Asphalt Laydown | | |
| Denver..... | \$ 22.67 | 8.72 |
| Douglas..... | \$ 23.67 | 8.47 |
| Asphalt Paver | | |
| Denver..... | \$ 24.97 | 6.13 |
| Douglas..... | \$ 25.44 | 3.50 |
| Asphalt Roller | | |
| Denver..... | \$ 23.13 | 7.55 |
| Douglas..... | \$ 23.63 | 6.43 |
| Asphalt Spreader..... | \$ 22.67 | 8.72 |
| Backhoe/Trackhoe | | |
| Douglas..... | \$ 23.82 | 6.00 |
| Bobcat/Skid Loader..... | \$ 15.37 | 4.28 |
| Boom..... | \$ 22.67 | 8.72 |
| Broom/Sweeper | | |
| Denver..... | \$ 22.47 | 8.72 |
| Douglas..... | \$ 22.96 | 8.22 |
| Bulldozer..... | \$ 26.90 | 5.59 |
| Concrete Pump..... | \$ 21.60 | 5.21 |
| Drill | | |
| Denver..... | \$ 20.48 | 4.71 |
| Douglas..... | \$ 20.71 | 2.66 |
| Forklift..... | \$ 15.91 | 4.68 |

| | | |
|---|-------------|------|
| Grader/Blade | | |
| Denver..... | \$ 22.67 | 8.72 |
| Guardrail/Post Driver..... | \$ 16.07 | 4.41 |
| Loader (Front End) | | |
| Douglas..... | \$ 21.67 | 8.22 |
| Mechanic | | |
| Denver..... | \$ 22.89 | 8.72 |
| Douglas..... | \$ 23.88 | 8.22 |
| Oiler | | |
| Denver..... | \$ 23.73 | 8.41 |
| Douglas..... | \$ 24.90 | 7.67 |
| Roller/Compactor (Dirt and Grade Compaction) | | |
| Denver..... | \$ 20.30 | 5.51 |
| Douglas..... | \$ 22.78 | 4.86 |
| Rotomill..... | \$ 16.22 | 4.41 |
| Screed | | |
| Denver..... | \$ 22.67 | 8.38 |
| Douglas..... | \$ 29.99 | 1.40 |
| Tractor..... | \$ 13.13 ** | 2.95 |

TRAFFIC SIGNALIZATION:

Groundsman

| | | |
|--------------|----------|------|
| Denver..... | \$ 17.90 | 3.41 |
| Douglas..... | \$ 18.67 | 7.17 |

TRUCK DRIVER

Distributor

| | | |
|--------------|----------|------|
| Denver..... | \$ 17.81 | 5.82 |
| Douglas..... | \$ 16.98 | 5.27 |

Dump Truck

| | | |
|--------------|----------|------|
| Denver..... | \$ 15.27 | 5.27 |
| Douglas..... | \$ 16.39 | 5.27 |

| | | |
|-------------------|----------|------|
| Lowboy Truck..... | \$ 17.25 | 5.27 |
|-------------------|----------|------|

| | | |
|---------------|----------|------|
| Mechanic..... | \$ 26.48 | 3.50 |
|---------------|----------|------|

Multi-Purpose Specialty &
Hoisting Truck

| | | |
|--------------|----------|------|
| Denver..... | \$ 17.49 | 3.17 |
| Douglas..... | \$ 20.05 | 2.88 |

Pickup and Pilot Car

| | | |
|--------------|-------------|------|
| Denver..... | \$ 14.24 ** | 3.77 |
| Douglas..... | \$ 16.43 | 3.68 |

| | | |
|-------------------------|----------|------|
| Semi/Trailer Truck..... | \$ 18.39 | 4.13 |
|-------------------------|----------|------|

| | | |
|------------------------------|-------------|------|
| Truck Mounted Attenuator.... | \$ 12.43 ** | 3.22 |
|------------------------------|-------------|------|

Water Truck

| | | |
|--------------|----------|------|
| Denver..... | \$ 26.27 | 5.27 |
| Douglas..... | \$ 19.46 | 2.58 |

WELDERS - Receive rate prescribed for craft performing
operation to which welding is incidental.

**Office of Human Resources
Supplemental Rates
(Specific to the Denver Projects)
Revised 01/01/2022)**

| Classification | | Base | Fringe |
|---|----------------------------------|-------------|---------------|
| Guard Rail Installer | | \$15.87 | \$3.20 |
| Highway Parking Lot Striping: Painter | | \$15.87 | \$3.21 |
| Ironworker (Ornamental) | | \$26.05 | \$12.00 |
| Laborer | Removal of Asbestos | \$21.03 | \$8.55 |
| Laborer (Landscape & Irrigation) | | \$15.87 | \$3.16 |
| Laborer: Traffic Control (Flagger) | | \$15.87 | \$3.05 |
| Laborer: Stationary Flags(excludes Flaggers) | | \$15.87 | \$3.22 |
| Line Construction | Lineman, Gas Fitter/Welder | \$36.88 | \$9.55 |
| | Line Eq Operator/Line Truck Crew | \$25.74 | \$8.09 |
| Millwright | | \$28.00 | \$10.00 |
| Pipefitter | | \$30.45 | \$12.85 |
| Plumber | | \$30.19 | \$13.55 |
| Power Equipment Operator (Tunnels Above and Below Ground, shafts and raises): | Group 1 | \$25.12 | \$10.81 |
| | Group 2 | \$25.47 | \$10.85 |
| | Group 3 | \$25.57 | \$10.86 |
| | Group 4 | \$25.82 | \$10.88 |
| | Group 5 | \$25.97 | \$10.90 |
| | Group 6 | \$26.12 | \$10.91 |
| | Group 7 | \$26.37 | \$10.94 |
| Power Equipment Operator | Group 1 | \$22.97 | \$10.60 |
| | Group 2 | \$23.32 | \$10.63 |
| | Group 3 | \$23.67 | \$10.67 |
| | Group 4 | \$23.82 | \$10.68 |
| | Group 5 | \$23.97 | \$10.70 |
| | Group 6 | \$24.12 | \$10.71 |
| | Group 7 | \$24.88 | \$10.79 |
| Truck Driver | Group 1 | \$18.42 | \$10.00 |
| | Group 2 | \$19.14 | \$10.07 |
| | Group 3 | \$19.48 | \$10.11 |
| | Group 4 | \$20.01 | \$10.16 |
| | Group 5 | \$20.66 | \$10.23 |
| | Group 6 | \$21.46 | \$10.31 |
| Truck Driver: Truck Mounted Attenuator | | \$15.87 | \$3.22 |

Go to <http://www.denvergov.org/Auditor> to view the Prevailing Wage Clarification Document for a list of complete classifications used.

CITY AND COUNTY OF DENVER
STATE OF COLORADO



DENVER
THE MILE HIGH CITY

**DEPARTMENT OF TRANSPORTATION &
INFRASTRUCTURE**

Addenda

Contract Number: 202263315

Connecting Auraria

June 6, 2022

**CITY AND COUNTY OF DENVER
DEPARTMENT OF TRANSPORTATION AND INFRASTRUCTURE**

**CONTRACT NO. 202263315
PROJECT NAME: Connecting Auraria**

**ADDENDUM NO. #1 TO CONTRACT DOCUMENTS
DATE OF ADDENDUM: June 28, 2022**

Bidders are hereby instructed that the drawings, specifications, and other contract documents are modified, corrected, supplemented and/or superseded for the above-mentioned project as hereinafter described in the following attachments:

BID DOCUMENTS AND ATTACHMENTS

- **BID DOCUMENTS PACKAGE:** Remove **Statement of Quantities** in its entirety and replace with updated **Statement of Quantities** attached to this Addendum #1.
- **BID FORM:** Updated BF-7 to reflect change in number of bid items.
- Bid worksheet in QuestCDN has also been updated to reflect these changes.

Attachment 1 - Revisions to Specifications

Attachment 2 - Revisions to Drawings

Attachment 3 – As-built Drawings

Attachment 4 – 404 Permit

QUESTIONS/ANSWERS

- Q1. Do SBE or EBE contractors count towards that goal? I am hopeful it does as there are very few Minority and Women Owned business available for quoting subcontracted work.
- A1. They will need to make sure the subs have an MWBE certification to count for this goal. The section in the ordinance that supports that is below. However, I noticed the attached list is showing only one certification in column N and these vendors have more. A couple examples such as Alpine Custom Concrete and C&H Asphalt Maintenance are SBE AND MWBE certified which would make them eligible. So I would direct them to our vendor directory where they might find the most up to date information on them: [Small Business Certification and Contract Management System | Denver Office of Economic Development \(mwdbe.com\)](https://www.mwdbe.com/).

Sec. 28-62. - Contracts for construction, reconstruction and remodeling—Compliance with participation goals.

[SHARE LINK TO SECTIONPRINT SECTIONDOWNLOAD \(DOCX\) OF SECTIONEMAIL SECTIONCOMPARE VERSIONS](#)

(a) The bid or competitive selection process specifications for each applicable contract shall require that all bidders or proposers seeking to contract with the city or a private owner on such project shall address the participation goal through one (1) or more of the following subsections, or by demonstrating good faith efforts as set out in [section 28-60](#):

- (1) If the bidder or proposer is an MWBE, the value of the commercially useful function to be self-performed by the MWBE shall count to the extent provided in [section 28-59](#) toward satisfaction of the participation goal. If the level of self-performed work does not satisfy the goal, the MWBE bidder or proposer must utilize additional MWBE firms or submit good faith efforts.

- Q2. Revision of Section 208 – Water Control states in measurement and payment that it will be paid under pay item “Water Control – 1 LS”. There isn’t a “Water Control” pay item listed in the statement of quantities. Will a pay item be added for “Water Control?”
- A2. **Yes, added to SOAQ, See Attachment 2**
- Q3. What is the anticipated award and Notice to Proceed dates?
- A3. **It is expected that award will occur in late July or early August, and Notice to Proceed will be in September**
- Q4. Revision of Section 208 – Erosion Control states in measurement and payment that it will be paid under pay item “Erosion Control – 1 LS”. There is an “Erosion Control” pay item listed as a force account. Will this pay item be used to pay for erosion control that there is not a specific pay item, such as, erosion control supervisor, etc?
- A4. **208 Erosion Control Items removed and replaced with Erosion Control – 1 LS. Items on Sheet 181 noted as For Information Only. See Attachment 2**
- Q5. Revision of Section 212 – Landscape Restoration states in measurement and payment that it will be paid under pay item “Landscape Restoration”. There isn’t a “Landscape Restoration” pay item listed in the statement of quantities. Will a pay item be added for “Landscape Restoration?”
- A5. **Yes added to SOAQ. See Attachment 2**
- Q6. Revision of Section 214 Planting. Below are the items listed in the specification versus what is in the statement of quantities? Will this specification be revised to include what is in the project scope?
Deciduous Tree (2.5 Inch Caliper) – Each (Deciduous Tree (3.0 Inch Caliper) – In statement of quantities.

Deciduous Shrub (1 Gallon Container) – Each (Deciduous Shrub (2 Gallon Container) & Deciduous Shrub (5 Gallon Container) – In statement of quantities.

1 Year Landscape Maintenance – LS (There is no bid item in the statement of quantities. Is this item not in the scope of work?)
- A6. **Specification revised to Deciduous Tree (3 Inch Caliper), Deciduous Shrub (2 Gallon Container) & added Deciduous Shrub (5 Gallon Container) 1 Year Landscape Maintenance added to SOAQ . See Attachments 1 & 2.**
- Q7. Revision of 250 – Environmental Health and Safety Management. In the technical specifications under the measurement and payment there is an item for Solid Waste, Excavation, Loading and Transportation with a unit of measure of cubic yards. There isn’t any item for this in the statement of quantities. The unit of measure in the technical specifications for Asbestos Containing Material Abatement is lump sum and in the statement of quantities the unit of measure is cubic yard. Please clarify correct unit of measure for item.
- A7. **Revisions**
1. **Item Solid Waste, Excavation, Loading and Transportation added to SOAQ, Spec updated for this item.**
 2. **Asbestos Containing Material Abatement Unit and Quantity updated on SOAQ**
 3. **Bridge Pre-Demolition Asbestos Inspection item deleted from SOAQ**
- See Attachments 1 & 2**

- Q8. Revision of Section 412 and 608 – Pavement, Sidewalks, Curb Ramps, and Bikeways technical specification unit of measure is square foot and statement of quantities in square yard for concrete pavement and curb ramps. In the statement of quantities the detectable directional warning tiles the unit of measure is linear feet and in the measurement and payment of the specifications the unit of measure is square feet. Please clarify. No measurement and payment in technical specifications for items detectable warning surface and detectable warning surface (cast iron). Technical specifications have payment for truncated domes (cast iron) and truncated domes, but these items are not included in statement of quantities. Please clarify.
- A8. All pavement is measured by the square yard. Changed Specification to be LF for directional Warning Tiles and changed name of Truncated Dome items to Detectable Warning Surface to match SOAQ. Plan revisions included to match naming convention. See Attachments 1 & 2**
- Q9. Revision of Section 613 – Electric Meter Pedestal Cabinet and Base. The measurement and payment in the technical specifications there is an item “Electric Meter Pedestal Cabinet and Base. There isn’t an item for this in the statement of quantities. Please clarify.
- A9. Changed SOAQ to match spec and plan #168. See Attachment 2**
- Q10. Revision of Section 613 Lighting - The following items in the technical specifications are not in the statement of quantities: P3 Street Luminaire, P1 Pedestrian Luminaire/Pole/Foundation, P2 Pedestrian Luminaire/Pole/Foundation, and U1 Under Bridge Lighting.
- A10. Lighting items removed and Force Account added in SOAQ. Specifications revised to indicate Xcel design and installation of all street lighting and associated materials. Xcel to invoice project for payment through the Lighting Force Account item. See Attachments 1 & 2**
- Q11. Revision of Section 613 Pull Box – General – The following items in the technical specifications are not in the statement of quantities: Pull Box (Type A) (Electric), Pull Box (Type 1) (City Electric), and Pull Box (Type 2) (City Electric). There is not information in the technical specifications for Pull Box (Special) and Pull Box (Surface Mounted) listed in the statement of quantities. Please clarify.
- A11. There are unused items in the spec as noted. Pull Box (Special) and Pull Box (Surface Mounted) will be defined by Xcel through their design and are removed from the SOAQ. See Attachment 2**
- Q12. Revision of Section 614 – Led Optic Blank-Out Signs – There is a pay item in the technical specifications for LED Blankout Sign, but no item in statement of quantities. Confirm this is not in the scope of the project.
- A12. Item was deleted from the project.**
- Q13. Revision of Section 630 – Construction Zone Traffic Control. The technical specifications have an item under measurement and payment of Construction Traffic Control - 1 LS. Will the Construction Traffic Control specification be revised to include the pay items in the statement of quantities?
- A13. Change tab to FIO and replace items with 1 LS. See Attachment 2**
- Q14. Revision of Section 635 – Site Furnishings – The measurement and payment in the technical specifications has an item for bike racks. Please confirm bike racks are not part of the project scope.
- A14. Stainless steel inverted “U” bike racks are part of the project and are included in the Landscape drawings. SOAQ has been updated. See Attachment 2**
- Q15. There are two anti-graffiti specifications in the technical specifications, one on page 95 and page 180. Please advise which specification is to be referenced for this project.
- A15. Section 708 is deleted. See Attachment 1**
- Q16. Are there any utilities on the existing bridge or within the project limits that will require relocation by the utility owners?
- A16. Known utility conflicts and proposed resolutions are shown on Sheet 145.**

- Q17. Silt Fence is shown on Sheet Number 183. Will an item be added to the statement of quantities?
A17. **Silt fence mislabeled as Temporary Fence on Sheet #181 and SOAQ. Will revise on 181 and delete from SOAQ due to payment under LS Erosion Control. See Attachment 2**
- Q18. Are as-built drawings for the existing bridge available?
A18. **See attached as-built drawings in Attachment 3**
- Q19. Is there a place on site intended for a laydown area and site trailer office?
A19. **No location has been identified for a laydown area or site trailer. Bidders may contact property owners in the area regarding options. The City project manager will assist in this effort if needed.**
- Q20. The project includes \$840,000 in force account that is included in the bid total. Is the 19% MWBE based on the total that includes the \$840,000 or is the 19% MWBE to be calculated on the bid total minus \$840,000?
A20. **The 19% MWBE goal includes the dollar amount in the force account in the bid total. So the answer is no, do not minus \$840,000 from the 19% this is included.**
- Q21. Do we need to provide a pedestal for providing the power to the new lights or do we need to tie them to the existing pedestal? If we need to tie to them to the existing pedestal, where is it located?
A21. **Xcel will complete the design and install all lighting components. Contractor to coordinate during construction. See Attachment 1**
- Q22. What size conduit and wire do we need to provide for the P1, P2 and P3 lights?
A22. **Xcel will complete the design and install. Contractor to coordinate during construction.**
- Q23. Sheet 83 of the plans shows three locations where pipe is to be removed. Will pay items for pipe removal be added to the statement of quantities?
A23. **Item added for Removal of Pipe to Sheet 84 and SOAQ. See Attachment 2**
- Q24. Will an item be added for the silt fence shown on Sheet 185?
A24. **See response to Q17.**
- Q25. Looking at Sheet 94, it appears there are 12 trees to be protected and on the statement of quantities, there is on 9 each? Please clarify.
A25. **Revise quantity to 12. See Attachment 2**
- Q26. How will the CIP Concrete Plinths shown on Sheet 96 (L4) and detailed Sheet 108 (L16) be paid?
A26. **Quantities added for the plinths to 601-04550 and 602-00020. See Attachment 2**
- Q27. Sheet 98 (L6) has two locations that state "Reinstate Trash Receptacle". There isn't an item in the statement of quantities and it is not addressed in the technical specifications. Please clarify?
A27. **This item has been called out on the removal plans as Reset Trash Receptacle. See Attachment 2**
- Q28. Sheet 103 (L11) has a breakdown of 1 Gal Perennials totaling 448 each. Will an item be added to the statement of quantities for 1 Gal Perennials?
A28. **Item for 1 Gal Perennials is at the bottom of the left column on sheet 8.**
- Q29. Sheet 107 (L15) has a detail for a bike rack and there isn't an item in the statement of quantities for bike racks, just removal of bike racks. Please confirm bike rakes are not in the scope of work for this project.
A29. **See response to Q#14.**

- Q30. How will the bioretention media be paid for in within the area of the concrete planter walls and water quality planter walls?
A30. **No bioretention media to be used on this project. Per the Denver Green Continuum Streets Guidelines, amended in-situ soils may be used for Flow Through Landscapes (Level of Green 3). See specification section 212.**
- Q31. How will the topsoil be paid associated with the shrub and perennial plantings?
A31. **Section 212 SEEDING, FERTILIZER, AND SOIL CONDITIONER includes specifications for topsoil and soil preparation.**
- Q32. How will the ¾” Wet Tap and associated work be paid for listed on Sheet 118?
A32. **If needed, tap will be paid for under Utility Tap Fee Force Account.**
- Q33. Sheet 145, 146, and 147 are not legible. Please issue sheets that is legible.
A33. **Sheets have been reissued. See Attachment 2**
- Q34. Sheet 185 of the Stormwater Management shows construction mat(s) in the channel of Cherry Creek. Sheet 190 has a description and basis of payment for the construction mat. Will an item be added to the statement of quantities to pay for this scope of work?
A34. **Sheet 190 revised to make this item incidental to the Water Control lump sum item. See Attachment 2**
- Q35. The bid form only indicates stating a total bid amount. There isn't a schedule of values for individual bid items included. Will a schedule of values be issued to be included in the bid form for individual unit prices and bid item totals or do individual unit prices get entered directly into QuestCDN?
A35. **Please go to the Bid Worksheet tab and download the bid worksheet. [Click here to view QuestCDN VBid Bidder Instructions; Microsoft Word - ++online bidding user guide..docx \(denvergov.org\)](#)**
- Q36. Can a copy of the 404 permit and other permits already acquired be issued?
A36. **404 permit document provided as Attachment 4. Other permits are in process and have not yet been acquired.**
- Q37. There is a bid item “Drilling Hole to Facilitate Pile Driving – 224 LF, however there is nothing in the technical specifications for measurement and payment.
In the geotechnical report it states:
“We understand the existing retaining walls are to remain in place and care should be exercised not to disturb these retaining walls. Therefore, prior to driving H-piles, we recommend at the H-pile locations to be predrilled to approximately 5 feet below the bottom of the retaining wall foundation. The diameter of the drilled hole shall be wider than the proposed H-piles and disposable casings should be inserted in the excavations to prevent caving during the H-pile installations. At the completion of the H-pile installations the casting shall be filled with flow fill or concrete and not conventional backfill material.
I am not sure how binding the Geotechnical report is on procedures and what will actually be required.
Can you clear this up please?
A37. **See Note 10 on Sheet 65 (B13). This work will be performed and paid in accordance with CDOT Standard Specification 502, specifically sections 502.07, 502.15, and 502.16.**

- Q38. The quantity in the statement of quantities for the asphalt paving is 818 SY. Sheet 20 in the tabulation of pavement items, there is 18 SY. Please clarify this discrepancy.
- A38. The correct quantity is 18 SY, the SOAQ has been revised accordingly. See Attachment 2**

This **ADDENDUM** shall be attached to, become a part of, and be returned with the Bid Proposal.

David Nemovitz
(Deputy City Engineer, on behalf of the City Engineer)

James G. Potter, City Engineer

July 5, 2022

Date

**CITY AND COUNTY OF DENVER
DEPARTMENT OF TRANSPORTATION AND INFRASTRUCTURE**

STATEMENT OF QUANTITIES

| ITEM NO. | DESCRIPTION | QTY | UNIT TYPE |
|----------------------|---|----------------|---------------|
| 201-00001 | CLEARING AND GRUBBING | 1 | LS |
| 202-00001 | REMOVAL OF STRUCTURE | 1 | EA |
| 202 | REMOVAL OF TREE GRATE | 4 | EA |
| 202 | REMOVAL OF BANNER POLE | 17 | EA |
| 202 | REMOVAL OF BIKE RACK | 7 | EA |
| 202 | REMOVAL OF PLANTER POT | 20 | EA |
| 202 | REMOVAL OF TRASH RECEPTICAL | 2 | EA |
| 202 | REMOVAL OF BENCH | 2 | EA |
| 202 | REMOVAL OF DELINEATOR | 11 | EA |
| 202 | REMOVAL OF DECORATIVE CROSSWALKS (PAINTED BRICK PATTERN) | 1,268 | SF |
| 202 | REMOVAL OF PRE CAST MEDIANS | 1 | LS |
| 202-00010 | REMOVAL OF TREE | 1 | EA |
| 202-00019 | REMOVAL OF INLET | 5 | EA |
| 202-00035 | REMOVAL OF PIPE | 118 | LF |
| 202-00175 | REMOVAL OF CONCRETE DRIVEWAY | 125 | SY |
| 202-00200 | REMOVAL OF CONCRETE SIDEWALK | 1,032 | SY |
| 202-00203 | REMOVAL OF CURB AND GUTTER | 868 | LF |
| 202-00206 | REMOVAL OF CONCRETE CURB RAMP | 115 | SY |
| 202-00210 | REMOVAL OF CONCRETE PAVEMENT | 1,789 | SY |
| 202-00220 | REMOVAL OF ASPHALT MAT | 812 | SY |
| 202-00250 | REMOVAL OF PAVEMENT MARKING | 909 | SF |
| 202-00810 | REMOVAL OF GROUND SIGN | 7 | EA |
| 202-00821 | REMOVAL OF SIGN PANEL | 21 | EA |
| 202-00828 | REMOVAL OF TRAFFIC SIGNAL EQUIPMENT | 1 | LS |
| 202-010000 | REMOVAL OF FENCE | 7 | LF |
| 202-04005 | CLEAN VALVE BOX | 2 | EA |
| 203-00010 | UNCLASSIFIED EXCAVATION(COMPLETE IN PLACE) | 434 | CY |
| 203-01597 | POTHOLING | 300 | HR |
| 206-00000 | STRUCTURE EXCAVATION | 485 | CY |
| 206-00100 | STRUCTURE BACKFILL (CLASS I) | 309 | CY |
| 206-00200 | STRUCTURE BACKFILL (CLASS 2) | 70 | CY |
| 206-00360 | MECHANICAL REINFORCEMENT OF SOIL | 309 | CY |
| 206-01781 | SHORING (Area 1) | 1 | LS |
| 208 | WATER CONTROL | 1 | LS |
| 208-00200 | EROSION CONTROL | 1 | LS |
| 208-00013 | EROSION CONTROL LOG (TYPE I) | 6 | LF |
| 208-00035 | AGGREGATE BAG | 240 | LF |
| 208-00045 | CONCRETE WASHOUT STRUCTURE | 2 | EA |
| 208-00053 | INLET PROTECTION (TYPE I) | 14 | EA |
| 208-00054 | INLET PROTECTION (TYPE II) | 2 | EA |
| 208-00070 | VEHICLE TRACKING PAD | 2 | EA |
| 210 | RESET PRE CAST MEDIANS | 1 | LS |
| 210 | RESET TRASH RECEPTACLE | 2 | EA |

**CITY AND COUNTY OF DENVER
DEPARTMENT OF TRANSPORTATION AND INFRASTRUCTURE**

STATEMENT OF QUANTITIES

| ITEM NO. | DESCRIPTION | QTY | UNIT TYPE |
|----------------------|---|--------------------|------------------|
| 210-00827 | RESET PULL BOX | 4 | EA |
| 210-00831 | RESET TRAFFIC SIGNAL HEAD | 2 | EA |
| 210-00842 | RESET TRAFFIC SIGNAL MAST ARM | 1 | EA |
| 210-04010 | ADJUST MANHOLE | 1 | EA |
| 210-04050 | ADJUST VALVE BOX | 2 | EA |
| 212-00005 | SEEDING (NATIVE) | .05 | ACRE |
| 212-01200 | LANDSCAPE RESTORATION | 1 | LS |
| 213-00000 | MULCHING | .05 | ACRE |
| 250-00010 | ENVIRONMENTAL HEALTH AND SAFETY MANAGEMENT | 1 | LS |
| 250-00110 | HEALTH AND SAFETY OFFICER | 20 | HR |
| 250 | MATERIAL SAMPLING AND DELIVERY- CHEMICAL | 5 | EA |
| 250 | MATERIAL SAMPLING AND DELIVERY- ASBESTOS | 20 | EA |
| 250 | MATERIALS MANAGEMENT PLAN SUPERVISOR | 80 | HR |
| 250 | CERTIFIED ASBESTOS BUILDING INSPECTOR | 80 | HR |
| 250 | ASBESTOS CONTAINING MATERIAL ABATEMENT | 17 | CY LS |
| 250 | SOLID WASTE EXCAVATION AND TRANSPORTING | 230 | CY |
| 250 | BRIDGE PRE-DEMOLITION ASBESTOS- INSPECTION | 4 | LS |
| 304-06007 | AGGREGATE BASE COURSE (CLASS 6) | 391 | CY |
| 403-00721 | HOT MIX ASPHALT (PATCHING) (ASPHALT) | 818 18 | SY |
| 412-00600 | CONCRETE PAVEMENT (6 INCH) | 617 595 | SY |
| 412-00800 | CONCRETE PAVEMENT (8 INCH) | 886 973 | SY |
| 502-00100 | DRILLING HOLE TO FACILITATE PILE DRIVING | 224 | LF |
| 502-11274 | STEEL PILING (HP 12X74) | 445 | LF |
| 503-00024 | DRILLED SHAFT (24 INCH) | 28 | LF |
| 503-00036 | DRILLED SHAFT (36 INCH) | 52 | LF |
| 504 | CONCRETE PLANTER WALL | 189 | LF |
| 504 | WATER QUALITY PLANTER WALL | 170 | LF |
| 506-00212 | RIPRAP (12 INCH) | 14 | CY |
| 509-00000 | STRUCTURAL STEEL | 42 | LB |
| 514-99999 | FENCE (SPECIAL)(6-18 INCH) | 81 | LF |
| 515-00400 | CONCRETE SEALER | 566 | SY |
| 519-03035 | PLACE THIN BONDED OVERLAY (POLYESTER CONCRETE) | 363 | SY |
| 519-03055 | FURNISH THIN BONDED OVERLAY (POLYESTER CONCRETE) | 205 | CF |
| 601-04550 | CONCRETE CLASS G | 366 | CY |
| 601-03040 | CONCRETE CLASS D (BRIDGE) | 372 | CY |
| 601-40300 | STRUCTURAL CONCRETE COATING | 313 | SY |

**CITY AND COUNTY OF DENVER
DEPARTMENT OF TRANSPORTATION AND INFRASTRUCTURE**

STATEMENT OF QUANTITIES

| ITEM NO. | DESCRIPTION | QTY | UNIT TYPE |
|----------------------|--|--------------------------|---------------|
| 601-40302 | STRUCTURAL CONCRETE COATING (ANTI-GRAFFITI) | 699 | SF |
| 602-00020 | REINFORCING STEEL (EPOXY COATED) | 44,343 44,748 | LB |
| 603-01155 | 15 INCH REINFORCED CONCRETE PIPE (CIP) | 54 | LF |
| 604-13005 | INLET TYPE 13 (5 FOOT) | 1 | EA |
| 604-13505 | INLET TYPE 13 (DOUBLE) (5 FOOT) | 1 | EA |
| 604-19110 | INLET TYPE R L 5 (10 FOOT) | 1 | EA |
| 605 | CONCRETE COLLAR | 1 | EA |
| 606-11035 | BRIDGE RAIL TYPE 10 MASH | 213 | LF |
| 607-11580 | TEMPORARY FENCE | 800 | LF |
| 608 | DETECTABLE DIRECTIONAL WARNING TILES | 609 | LF |
| 608-00010 | CONCRETE CURB RAMP | 288 | SY |
| 608 | DETECTABLE WARNING SURFACE | 150 | SF |
| 608 | DETECTABLE WARNING SURFACE (CAST IRON) | 227 | SF |
| 609-20010 | CURB AND GUTTER TYPE 2 (SECTION B) | 37 | LF |
| 609-21010 | CURB AND GUTTER TYPE 2 (SECTION I-B) | 77 | LF |
| 609-21020 | CURB AND GUTTER TYPE 2 (SECTION II-B) | 316 | LF |
| 609-71000 | CURB (SPECIAL) | 200 | LF |
| 612-00039 | DELINEATOR (FLEXIBLE) (SURFACE MOUNTED) | 34 | EA |
| 612 | PRECAST CONCRETE MEDIAN | 25 | EA |
| 613-00100 | 1 INCH ELECTRICAL CONDUIT | 144 | LF |
| 613-00100 | 1 INCH ELECTRICAL CONDUIT (PVC) | 100 | LF |
| 613-00102 | 1 INCH ELECTRICAL CONDUIT (GALVANIZED RIGID CONDUIT) (SPECIAL) | 100 | LF |
| 613-00200 | 2 INCH ELECTRICAL CONDUIT | 802 | LF |
| 613-00300 | 3 INCH ELECTRICAL CONDUIT | 1,002 | LF |
| 613 | INTERCONNECT 3-INCH ELECTRICAL CONDUIT | 289 | LF |
| 613 | PULL BOX TYPE B (TRAFFIC) | 9 | EA |
| 613 | PULL BOX TYPE C (TRAFFIC COMM) | 3 | EA |
| 613-07000 | PULL BOX (SPECIAL) | 1 | EA |
| 613-07010 | PULL BOX (SURFACE MOUNTED) | 2 | EA |
| 613-10000 | WIRING | 1 | LS |
| 613 | LUMINAIRE (LED) (5300 LUMENS) (55 WATT) | 8 | EA |
| 613-15000 | FLOODLIGHT | 4 | EA |
| 613-34250 | LIGHT STANDARD METAL (25 FOOT) | 1 | EA |
| 613-50109 | METER POWER PEDESTAL ELECTRIC METER PEDESTAL CABINET AND BASE | 1 | EA |
| 614-00011 | SIGN PANEL (CLASS I) | 150 | SF |
| 614-00012 | SIGN PANEL (CLASS II) | 51 | SF |
| 614-00216 | STEEL SIGNPOST (2X2 INCH TUBING) | 47 | LF |
| 614-70117 | PEDESTRIAN SIGNAL FACE (16) | 16 | EA |
| 614-70324 | TRAFFIC SIGNAL FACE (8-8-8) | 4 | EA |
| 614-70336 | TRAFFIC SIGNAL FACE (12-12-12) | 19 | EA |
| 614-72855 | TRAFFIC SIGNAL CONTROLLER CABINET | 2 | EA |
| 614-81000 | TRAFFIC SIGNAL-LIGHT POLE STEEL | 4 | EA |

**CITY AND COUNTY OF DENVER
DEPARTMENT OF TRANSPORTATION AND INFRASTRUCTURE**

STATEMENT OF QUANTITIES

| ITEM NO. | DESCRIPTION | QTY | UNIT TYPE |
|-----------------|--|------------|------------------|
| 614-81120 | TRAFFIC SIGNAL-LIGHT POLE STEEL (1-20 FOOT MAST ARM) | 1 | EA |
| 614-81125 | TRAFFIC SIGNAL-LIGHT POLE STEEL (1-25 FOOT MAST ARM) | 1 | EA |
| 614-81150 | TRAFFIC SIGNAL LGIHT POLE STEEL (1-50 FOOT MAST ARM) | 1 | EA |
| 614-81155 | TRAFFIC SIGNAL LGIHT POLE STEEL (1-55 FOOT MAST ARM) | 1 | EA |
| 614-84100 | TRAFFIC SIGNAL PEDESTAL POLE ALUMINUM | 3 | EA |
| 614-86105 | TELEMETRY (FIELD) | 2 | EA |
| 614 | EMERGENCY VEHICLE TRAFFIC SIGNAL PRIORITY CONTROL SYSTEM | 2 | EA |
| 614-87333 | CLOSED CIRCUIT TELEVISION CAMERA (TRAFFIC SURVEILLANCE) | 2 | EA |
| 618-01994 | PRESTRESSED CONCRETE BOX (32" THROUGH 48") | 6,075 | SF |
| 623 | HI-POP SPRAY HEAD- 12" | 116 | EA |
| 623 | ELECTRIC CONTROL VALVE- CONVENTIONAL | 2 | EA |
| 623 | ELECTRIC CONTROL VALVE- TWO WIRE | 2 | EA |
| 623-07500 | SOIL MOISTURE SENSOR | 2 | EA |
| 623 | RAIN SENSOR | 1 | EA |
| 623 | ELECTRIC CONTROLLER- TWO WIRE | 1 | EA |
| 623 | RP BACKFLOW PREVENTER- 1" | 1 | EA |
| 623 | BACKFLOW PREVENTER ENCLOSURE | 1 | EA |
| 623 | QUICK COUPLING VALVE | 3 | EA |
| 623 | HYDROMETER- 1" | 1 | EA |
| 623-02008 | MANUAL DRAIN VALVE | 3 | EA |
| 623-05012 | GATE VALVE- 1-1/2" | 1 | EA |
| 623 | HDPE MAINLINE- 1-1/2" | 150 | LF |
| 623 | PVC LATERAL- 1" | 1,000 | LF |
| 623 | PVC SLEEVING- 2" | 250 | LF |
| 623 | PVC SLEEVING- 4" | 200 | LF |
| 623-00165 | DRIP VALVE ASSEMBLY- 1-1/2" | 1 | EA |
| 623-00162 | SUBSURFACE DRIPLINE | 575 | EA |
| 623 | DRIP LINE BLOW-OUT STUB ASSEMBLY | 2 | EA |
| 623 | ARRESTOR WITH GROUNDING PLATE | 2 | EA |
| 623 | VALVE DECODER | 3 | EA |
| 623 | MAXI TWO WIRE CABLE | 150 | LF |
| 619-00003 | WATER METER- 3/4" | 1 | EA |
| 625-00000 | CONSTRUCTION SURVEYING | 1 | LS |
| 626-01112 | PUBLIC INFORMATION MANAGEMENT (TIER II) | 175 | DAY |
| 627-00003 | THERMOPLASTIC PAVEMENT MARKING (INLAID) | 74 | SF |
| 627-00008 | MODIFIED EPOXY PAVEMENT MARKING | 21 | GAL |

**CITY AND COUNTY OF DENVER
DEPARTMENT OF TRANSPORTATION AND INFRASTRUCTURE**

STATEMENT OF QUANTITIES

| ITEM NO. | DESCRIPTION | QTY | UNIT TYPE |
|--|--|----------------------|----------------|
| 627-30405 | PREFORMED THERMOPLASTIC PAVEMENT MARKING (WORD/ SYMBOL) | 854 | SF |
| 627-30410 | PREFORMED THERMOPLASTIC PAVEMENT MARKING (XWALK/ STOP LINE) | 1,854 | SF |
| 629-01210 | ADJUST MONUMENT BOX | 1 | EA |
| 630 | TRAFFIC CONTROL | 1 | LS |
| 630-00000 | FLAGGING | 480 | HR |
| 630-00003 | UNIFORMED TRAFFIC CONTROL | 16 | HR |
| 630-00007 | TRAFFIC CONTROL INSPECTION | 70 | DAY |
| 630-00012 | TRAFFIC CONTROL MANAGEMENT | 170 | DAY |
| 630-80335 | BARRICADE (TYPE 3 M-A) (TEMPORARY) | 18 | EA |
| 630-80336 | BARRICADE (TYPE 3 M-B) (TEMPORARY) | 13 | EA |
| 630-80341 | CONSTRUCTION TRAFFIC SIGN (PANEL SIZE A) | 105 | EA |
| 630-80342 | CONSTRUCTION TRAFFIC SIGN (PANEL SIZE B) | 14 | EA |
| 630-80355 | PORTABLE MESSAGE SIGN PANEL | 1 | EA |
| 630-80357 | ADVANCE WARNING FLASHING OR-SEQUENCING ARROW PANEL (B FLASH ARROW-PANEL (B TY) TYPE) | 5 | EA |
| 630-80360 | DRUM CHANNELIZING DEVICE | 74 | EA |
| 630-80370 | BARRIER (TEMPORARY) | 250 | LF |
| <u>URBAN DESIGN/LANDSCAPE ITEMS</u> | | | |
| 212-00101 | TREE PROTECTION | 912 12 | EA |
| 213 | WOOD MULCH | .03 475 | ACRE CF |
| 214-00000 | 1 YEAR LANDSCAPE MAINTENANCE | 1 | LS |
| 214-00230 | DECIDUOUS TREE (3 INCH CALIPER) | 9 | EA |
| 214-00320 | DECIDUOUS SHRUB (2 GALLON CONTAINER) | 187 | EA |
| 214-00350 | DECIDUOUS SHRUB (5 GALLON CONTAINER) | 65 | EA |
| 214-00910 | PERENNIALS (1 GALLON CONTAINER) | 448 | EA |
| 412 | CONCRETE PAVEMENT (6 INCH) (COLORED) | 772 761 | SY |
| 412 | CONCRETE PAVEMENT (8 INCH) (COLORED) | 1,009 914 | SY |
| 613-30005 | LIGHT STANDARD AND LUMINAIRE-(PEDESTRIAN) | 12 | EA |
| 622 | BICYCLE RACK | 9 | EA |
| 622 | FREESTANDING PLANTER A | 25 | EA |
| 622 | FREESTANDING PLANTER B | 6 | EA |
| 622 | CIP CONCRETE BENCH SEAT | 132 | LF |
| 622 | BENCH TOPPER | 22 | EA |
| 622 | STACKED TIMBER BENCH | 1 | EA |
| 622 | TIMBER BENCH | 2 | EA |
| 700-70305 | AESTHETICS | 1 | F/A |
| 700-70010 | MINOR CONTRACT REVISIONS | 1 | F/A |
| 700-70072 | OBTAIN POWER FROM XCEL | 1 | F/A |
| 700-70175 | UNKNOWN UTILITIES | 1 | F/A |
| 700-70210 | LIGHTING | 1 | F/A |
| 700-70236 | PERMITS | 1 | F/A |

**CITY AND COUNTY OF DENVER
DEPARTMENT OF TRANSPORTATION AND INFRASTRUCTURE**

STATEMENT OF QUANTITIES

| ITEM NO. | DESCRIPTION | QTY | UNIT TYPE |
|-----------------|---|------------|------------------|
| 700-70245 | UTILITY TAP FEE | 1 | F/A |
| 700-70380 | EROSION CONTROL | 1 | F/A |
| 700-70581 | AIR MONITORING SPECIALIST | 1 | F/A |
| 700-70588 | RACS EXCAVATION, LOADING, AND TRANSPORTATION | 1 | F/A |
| LS1 | MOBILIZATION | 1 | LS |
| LS2 | TESTING/QUALITY CONTROL | 1 | LS |

| |
|--|
| <p style="text-align: right; color: red; margin: 0;">Seventy-Five [175]</p> <p>Sum of estimated cost for item numbers <u>201-00001 through LS2 (One Hundred Ninety-One [191] base bid items) and the Textura Fee equals Total Base Bid Amount:</u></p> <hr/> <hr/> <p style="text-align: right;">Dollars (\$ _____)</p> |
|--|

If the Manager mails a written Notice of Apparent Low Bidder, addressed to the Bidder's business address stated on this Bid Form, the Undersigned Bidder shall, in accordance with the Contract Documents, be ready to, and shall, within five (5) days after the date of the Notice: (i) execute the attached form of Contract in conformity with this bid; (ii) furnish the required proofs of insurance; and (iii) furnish the required bond or bonds in the sum of the full amount of this bid, executed by a surety company acceptable to the Manager.

The _____, a corporation of the State of _____, is hereby offered as Surety on said bond. If such surety is not approved by the Manager, another and satisfactory surety company shall be furnished.

Enclosed with this bid is a bid guarantee, as defined in the attached Instructions to Bidders, in the amount of _____. The Undersigned Bidder agrees that the entire amount of this bid guarantee is to be paid to and become the property of the City as liquidated damages, and not as a penalty, if: (i) the bid is considered to be the best by the City; (ii) the City notifies the Undersigned Bidder that it is the Apparent Low Bidder; and (iii) the Undersigned Bidder fails to execute the Contract in the form prescribed or to furnish the required bond and proofs of insurance, within five (5) days after the date of such notification.

The following persons, firms or corporations are interested with the Undersigned Bidder in this bid:

Name: _____ Name: _____

Address: _____ Address: _____

If there are no such persons, firms, or corporations, please so state in the following space:

PROJECT SPECIAL PROVISIONS (CONTINUED)

The following special provisions supplement or modify the Standard Specifications and take precedence over the Standard Specifications and plans.

| | <u>Date</u> | <u>Page</u> |
|---|-----------------------|-------------|
| Index Pages..... | (May 24, 2022) | 2-3 |
| CDOT Standard Special Provisions | (May 24, 2022) | 4 |
| General Project Description | (May 24, 2022) | 5 |
| Performance of Safety Critical Work | (May 24, 2022) | 6-8 |
| Revision of Section 201 – Clearing and Grubbing..... | (May 24, 2022) | 9 |
| Revision of Section 202 – Removal of Trees | (May 24, 2022) | 10 |
| Revision of Section 202 – Removal of Bridge | (May 24, 2022) | 11-14 |
| Revision of Section 202 – Removal of Inlet..... | (May 24, 2022) | 15 |
| Revision of Section 202 – Removal of Fence (Special)..... | (May 24, 2022) | 16 |
| Revision of Section 202 and 412 – Removal and Replacement of Concrete Pavement .. | (May 24, 2022) | 17-18 |
| Revision of Section 203 – Embankment Material..... | (May 24, 2022) | 19 |
| Revision of Section 208 – Water Control..... | (May 24, 2022) | 20-25 |
| Revision of Section 208 – Erosion Control..... | (May 24June 28, 2022) | 26-37 |
| Revision of Section 208 – Watering and Dust Palliatives..... | (May 24, 2022) | 38 |
| Revision of Section 210 – Valve Box and Manhole Adjustments | (May 24, 2022) | 39-40 |
| Revision of Section 212 – Protection of Existing Vegetation (Special)..... | (May 24, 2022) | 41-51 |
| Revision of Section 212 – Seeding, Fertilizer, Soil, and Conditioner..... | (May 24, 2022) | 52-56 |
| Revision of Section 212 – Landscape Restoration | (May 24, 2022) | 57 |
| Revision of Section 213 – <u>MulchingWood Mulch</u> | (May 24June 28, 2022) | 58 |
| Revision of Section 214 – Planting | (May 24June 28, 2022) | 59-65 |
| Revision of Section 250 – Environmental Health and Safety Management..... | (May 24June 28, 2022) | 66-71 |
| Revision of Section 403 – Hot Mix Asphalt..... | (May 24, 2022) | 72 |
| Revision of Section 503 – Drilled and Vacuumed Caisson..... | (May 24, 2022) | 73 |
| Revision of Section 504 – Planter Walls..... | (May 24, 2022) | 74 |
| Revision of Section 514 – Fence (Special)..... | (May 24, 2022) | 75 |
| Revision of Section 522 – Thin Bonded Overlay (Polyester Concrete)..... | (May 24, 2022) | 76-88 |
| Revision of Section 522 – Duplex Coating System | (May 24, 2022) | 89-94 |
| Revision of Section 601 – Structural Concrete Coating (Anti-Graffiti)..... | (May 24, 2022) | 95 |
| Revision of Section 603 – Culverts and Sewers..... | (May 24, 2022) | 96 |
| Revision of Section 603 – Manholes and Inlets | (May 24, 2022) | 97 |
| Revision of Section 608 and 412 – Sidewalks, Curb Ramps, and Bikeways..... | (May 24June 28, 2022) | 98-101 |
| Revision of Section 613 – Electrical Conductor Identification..... | (May 24, 2022) | 102 |
| Revision of Section 613 – Electrical Conduit – General..... | (May 24, 2022) | 103-104 |
| Revision of Section 613 – Electric Meter Pedestal Cabinet and Base | (May 24, 2022) | 105 |
| Revision of Section 613 – Lighting..... | (May 24June 28, 2022) | 106-107 |
| Revision of Section 613 – Pull Boxes – General..... | (May 24, 2022) | 108-109 |
| Revision of Section 614 – Concrete Footing (Traffic Signal Pole)..... | (May 24, 2022) | 110 |

-4-

REVISION OF SECTION 208 EROSION CONTROL

The Contractor shall coordinate the construction of temporary BMPs with the construction of permanent BMPs to assure economical, effective, and continuous erosion and sediment control and water pollution prevention throughout the construction period until Final Stabilization is achieved

When a provision of this Section or an order by the Permit Enforcement Authority requires that an action be immediate or taken immediately, it shall be understood that the Contractor shall at once begin effecting completion of the action and pursue it to completion in a manner acceptable to the Permit Enforcement Authority, and in accordance with applicable Permitting requirements.

PART III: MATERIALS

The materials to be used for BMPs shall conform to each specific detail as set forth within the Project SWMP or as noted on the Contract Drawings.

PART IV: EROSION CONTROL PERMIT STATUS

The current SWMP status for the Project is as follows:

The Contractor shall submit a complete SWMP and application to the Permit Authority to obtain the required CASDP. The Contractor shall use the provided "For reference only" erosion control drawings provided in the Contract as a starting point for preparation of required SWMP elements (as required for CASDP) and for general information as to the origin of pay items included in the Bid Documents. The included erosion control drawings have been previously reviewed by the Permit Authority, and the BMPs shown therein have been found to be generally acceptable by the Permit Authority.

It shall be the responsibility of the Contractor to prepare and acquire approval of a complete SWMP and obtain a CASDP from the Permit Authority prior to beginning construction. The Contractor is hereby made aware that the Permit Authority allots up to 3 weeks per review cycle for CASDP applications (2 or more review cycles are not uncommon).

Per CASDP requirements, the Contractor shall obtain the endorsement of a Professional Engineer licensed in the State of Colorado for preparation of the initial SWMP and/ or any proposed Major or Minor SWMP Amendments. This will require the Contractor to provide or retain a Professional Engineer or subcontract with the original Professional Engineer of the "For reference only" erosion control drawings.

Per definition, a Major SWMP Modification requires the submission of revised SWMP elements to the Permit Authority for review and approval.

Prior to construction, the Contractor shall obtain the required State Construction Stormwater Permit(s) as applicable.

An approved SWMP has been prepared and CASDP obtained by the City prior to bidding of the Project and as such must be properly transferred to the Contractor prior to the start of construction. The SWMP has been provided within the Bid Documents and shall be made a part of the Contract. The Contractor shall coordinate with the Project Manager and Permit Authority to perform the necessary transfer of CASDP from City to Contractor prior to the start of construction. The CASDP transfer form can be obtained at:

<https://www.denvergov.org/Portals/711/documents/CASDP%20TRANSFER%20FORM.pdf>. The Permit transfer will be performed at no cost to the Contractor.

Prior to transfer of CASDP, additional elements shall be completed by the Contractor before the CASDP will be transferred from City to Contractor:

- (i) Complete Sections B&E (Permittee & Site Supervisor) of the CASDP "Narrative Report Information Worksheet".

- ~~(ii) Prepare a complete SWMP including any required adjustments for proposed construction phasing, staging areas, or additional items necessary to address applicable project specific Permit requirements. This will require the Contractor to provide or retain a Professional Engineer or subcontract with the original Professional Engineer that prepared the Bid Documents.~~
- ~~(iii) Complete the "Construction Scheduling" section of the "Narrative Report Information Worksheet".~~
- ~~(iv) Include specific methods and/or BMPs that the Contractor will implement to address hazardous spill prevention/containment response.~~
- ~~(v) Provide any "Additional Documentation and Correspondence" applicable to the Contractor as stated in the CASM. This will require the Contractor to provide or retain a Professional Engineer or subcontract with the original Professional Engineer that prepared the Bid Documents.~~

~~If deemed necessary, the Contractor may propose modifications to the approved SWMP once the CASDP has been transferred to the Contractor. Per CASDP requirements, the Contractor shall obtain the endorsement of a Professional Engineer licensed in the State of Colorado for any proposed Major or Minor SWMP Amendments. This may require the Contractor to provide or retain a Professional Engineer or subcontract with the original Professional Engineer of the "For reference only" erosion control drawings.~~

~~-5-~~

~~REVISION OF SECTION 208 EROSION CONTROL~~

~~Per definition, a Major SWMP Modification requires the submission of revised SWMP elements to the Permit Authority for review and approval.~~

~~Prior to construction, the Contractor shall obtain the required State Construction Stormwater Permit(s) as applicable. If the City has already obtained the State Construction Stormwater Permit, it shall be transferred to the contractor in the same way as the CASDP. The State Stormwater Permit Transfer form can be obtained at: <https://cdphe.colorado.gov/wq-per-forms>~~

PART V: CONSTRUCTION REQUIREMENTS

A) SCHEDULES:

At least 10 working days prior to the beginning of any construction work, the Contractor shall submit for approval a schedule for accomplishment of temporary and permanent BMPs shown in the SWMP. This schedule shall specifically indicate the sequence of clearing and grubbing, earthwork operations, and construction of temporary and permanent BMPs. The schedule shall include BMPs for all areas within the Project boundaries, including but not limited to, haul roads, borrow pits, and storage and other staging sites. Work shall not be started until the BMP schedule has been approved in writing by the Project Manager, and on site pre-construction inspection is performed and approved by CCD's NPDES inspector. Once the work has started, and during the active construction period, the Contractor shall update the schedule for all BMPs on a regular basis, and as required to keep the SWMP in compliance.

B) CONSTRUCTION IMPLEMENTATION: The Contractor shall incorporate into the Project all BMPs that are appropriate for the current phase of work, as outlined in the accepted schedule.

C) UNFORSEEN CONDITIONS: The Contractor shall direct the ECS (under the supervision of a Professional Engineer licensed in the State of Colorado) to design and implement BMPs for correcting conditions unforeseen during design of the Project, or as possible for emergency situations, which arise during construction. The Project's SWMP, UDFCD Vol 3 standards and details, and CDOTs "Erosion Control and Storm-Water Quality Guide," and any approved modification to these documents as proposed by the Contractor, shall be used as reference documents for the purpose of designing appropriate BMPs. Measures and methods proposed by the Contractor to deal with

Contract Control No. 2021-PROJMSTR-0000693

May 24, 2022

unforeseen conditions shall be reviewed and approved in writing by the Permit Enforcement Authority and the Project Manager prior to implementation and construction.

In an emergency situation, the Contractor shall use best judgment for immediately responding to the emergency situation as it arises, and shall notify the Permit Enforcement Authority and ECS of the emergency situation and BMPs employed in response as soon as practical after installation.

D) PERMITS:

The Contractor shall obtain all required permits for the Project including those required by federal, state, and local agencies. The Contractor shall obtain (or transfer from the City when specified) required erosion control and water quality permits and shall be responsible for compliance with all requirements under any such permits.

E) EROSION CONTROL SUPERVISOR:

Contractor shall assign to the Project an employee or subcontractor to serve as Erosion Control Supervisor (ECS). The ECS shall be a person other than the Contractor's superintendent, foreman, or equivalent supervisory position. The ECS shall be experienced in aspects of BMP construction and have satisfactorily completed a Colorado DOT or equivalent ECS training program authorized by the City. Proof that this requirement has been

-6-

**REVISION OF SECTION 208
EROSION CONTROL**

met shall be submitted to the Project Manager at least ten working days prior to the beginning of any soil disturbance work. A list of authorized ECS training programs is available from the City upon request. Additionally, per definition, the ECS shall be under the direction of a Professional Engineer licensed in the State of Colorado when performing any modifications to the Project Stormwater Management Plan (SWMP).

The ECS shall be responsible for oversight of the implementation, maintenance, and revision of the SWMP for the duration of the Project. CCD requires the ECS to fulfill responsibilities as outlined by CDPS such as having financial control and authority to implement BMPs. The ECS's responsibilities shall be as follows:

- 1) Ensure compliance with all water quality permits or certifications in effect during the construction work.
- 2) Supervise the installation, construction, and maintenance of all BMPs specified in the Contract and coordinate the construction of BMPs with all other construction operations.
- 3) Direct the implementation of suitable BMPs as necessary to correct unforeseen conditions or emergency situations. Direct the dismantling of those features when their purpose has been fulfilled due to completion of each Project phase unless the Permit Enforcement Authority agrees that the features be left in place.
- 4) Attend the preconstruction conference, erosion control preconstruction inspection, Project scheduling meetings, weekly construction/ field meetings, substantial completion and final stabilization inspections, and other meetings regarding construction that could impact water quality.
- 5) Evaluate all non-stormwater coming onto the site, such as springs, seeps, and landscape irrigation return flow. If such flow is identified, the ECS shall propose appropriate SWMP modifications to the Contractor to protect off-site water from becoming contaminated with sediment or other pollutants.
- 6) Coordinate with the Contractor to implement necessary actions to reduce anticipated or presently existing water quality or erosion problems resulting from construction activities.
- 7) Coordinate with the Contractor to ensure all labor, material, and equipment deployed to meet SWMP requirements is judged appropriately.
- 8) During construction, update and record the following items in the SWMP as changes occur:

- (i) Construction boundaries (may require Major SWMP Modification)
- (ii) Areas of disturbance (may require Major SWMP Modification)
- (iii) Areas used for storage of construction materials, equipment, soils, or wastes.
- (iv) Location of any dedicated asphalt or concrete batch plants.
- (v) Location of construction offices and staging areas.
- (vi) Location of work access routes during construction.
- (vii) Location of borrow and waste.
- (viii) Location of temporary and permanent stabilization

The ECS shall start a new site map before the current one becomes illegible. All site maps shall remain with the SWMP paperwork.

-7-

**REVISION OF SECTION 208
EROSION CONTROL**

- 9) Amend the SWMP whenever there are: additions, deletions, or changes in locations of BMPs. SWMP revisions shall be recorded immediately. Items shall be dated and signed at time of occurrence. Specifically, amendments shall include the following:
- (i) A change in design, construction, operation, or maintenance of the site which would require the implementation of new or revised BMPs; or
 - (ii) Changes when the SWMP proves to be ineffective in achieving the general objectives of controlling pollutants in stormwater discharges associated with construction activity.
 - (iii) Changes when temporary BMPs are no longer necessary from changes in Project phase and are removed. All inspection and maintenance activities or other repairs shall be documented.
- All inspection and maintenance activities or other repairs shall be documented. The SWMP and documentation shall be kept on the Project site at all times.
- 10) Modify the site map with arrows to indicate direction of surface and storm water flowing across the Project site.
- 11) When adding or revising BMPs in the SWMP, amend the narrative to explain what, when, where, why, and how the BMP is being used, and add a detail to the SWMP.
- 12) If using existing topography, vegetation, etc. as a BMP, label it as such in the SWMP site map; amend the Narrative to explain when, why, and how the BMP is being used in the SWMP.
- 13) Record on the SWMP, and implement the approved plan for concrete and asphalt saw cutting, grinding, and milling containment and removal.
- 14) Update the potential pollutants list in the SWMP throughout construction meeting CASDP requirements.
- 15) Spills, leaks, or overflows that result in the discharge of pollutants shall be documented on the inspection form. The ECS shall record the time and date, weather conditions, reasons for spill, and how it was remediated. The ECS shall immediately report to the Contractor and Project Manager the following instances of noncompliance:
- (i) Noncompliance which may endanger health or environment.
 - (ii) Spills or discharge of hazardous substance or oil which may cause pollution of the City MS4 or State Waters.

- (iii) Discharge of stormwater which may cause an exceedance of a water quality standard.

16) Perform a thorough inspection of the stormwater management system at least every seven (7) days and within 24 hours after any precipitation or snowmelt event with the potential to cause surface erosion. If no land disturbing construction activities are present during a storm event, post-storm event inspections shall be conducted prior to commencing any new land disturbing construction activities, but no later than seventy-two (72) hours following the storm event. The inspection records shall be kept on-site in a written or previously approved format. Inspections shall be conducted during the progress of the work, during work suspensions, or until Final Stabilization of all disturbed areas is approved by Permit Enforcement Authority and shall include the following services at a minimum:

-8-

**REVISION OF SECTION 208
EROSION CONTROL**

- (i) The construction site perimeter, disturbed areas, and areas used for material storage that are exposed to precipitation shall be inspected for evidence of, or the potential for, pollutants entering the drainage system. BMPs identified in the SWMP shall be observed to ensure that they are operating correctly.
- (ii) The description of potential pollutant sources, and the BMPs identified in the SWMP, shall be revised and modified as appropriate based on the results of the inspection as soon as practicable after such inspection. Modification to the SWMP shall be implemented in a timely manner and in accordance with applicable Permit requirements.
- (iii) The operator shall keep a record of inspections. Uncontrolled releases of sediment or polluted storm water or measurable quantities of sediment found off the site shall be recorded with a brief explanation as to the measures taken to prevent future releases as well as any measures taken to clean up the sediment that has left the site. Inspection records shall be made available to the City upon request. Note: documentation of uncontrolled releases at site DOES NOT alleviate any State or Federal requirements for reporting of discharges or upset conditions. Care shall be taken to ensure compliance with all regulatory requirements at site.
- (iv) Seven (7) day inspections are required during construction and at all times until Final Stabilization has been achieved. Seeding and mulching of disturbed areas does NOT count as final stabilization until such time as 70% pre disturbed vegetative cover has been achieved. Sites with growth in place sufficient to deter erosion that have not yet achieved final stabilization may petition the City to grant an alternative inspection schedule while awaiting additional growth for final stabilization. These inspections must be conducted in accordance with the above paragraphs.

F) APPLYING BMPs TO STABILIZE SITE:

The duration of the exposure of incomplete construction to the effects of weather shall be as short as practicable. BMPs such as: seeding, surface roughening, mulching, applying tackifier, use of geotextiles and matting, permanent landscaping, or other selected BMPs shall be applied within fourteen (14) calendar days of completion of grading/soil disturbance activities to stabilize the construction site unless disturbed area is within 100 feet of an MS4 or State Waters or has slopes of 3 to 1 or greater in which case BMPs shall be implemented within seven (7) calendar days of completion of grading activities. Disturbed areas where work is temporarily halted shall be temporarily stabilized within seven (7) days after the activity ceased unless work is to be resumed within thirty (30) calendar days after the activity ceased.

Clearing and grubbing operations shall be scheduled and performed to minimize both the area of the Project disturbed at a given time and the amount of time that disturbed areas remain open. BMPs such as temporary seeding are required between successive construction stages when disturbed areas will not be stable or active for thirty (30) calendar days or more. No payment will be made for additional work required because the Contractor has failed to properly coordinate the BMP schedule, thus causing previously stabilized areas to be disturbed by operations that could have been performed prior to the stabilization. Upon failure of the Contractor to coordinate the permanent BMPs with the grading operations in a manner to effectively control erosion and prevent water pollution, the Permit Enforcement Authority can suspend the Contractor's grading operations and the Project Manager can withhold monies due to the Contractor on current estimates until such time that all aspects of the work are coordinated in an acceptable manner.

-9-

**REVISION OF SECTION 208
EROSION CONTROL**

G) WORK OUTSIDE LIMITS OF CONSTRUCTION: Non-contiguous areas outside the limits of construction that are used by the Contractor that include, but are not limited to, borrow pits, haul routes, storage and disposal areas, field offices, maintenance, batching areas, etc., shall have appropriate BMPs implemented by the Contractor at the Contractor's expense. Should said areas meet applicable CASDP Permit criteria, the Contractor shall obtain a separate CASDP or amend existing CASDP for each area as applicable at no additional expense to the City.

H) MAINTENANCE: The Contractor shall continuously maintain erosion and sediment control BMPs on a daily basis or as directed by the ECS so that they function properly during and after construction (including work suspensions) until Final Stabilization has been approved by the Permit Enforcement Authority. Maintenance includes, but is not limited to, the following items:

- (i) From the time seeding and mulching work begins until the date the Project has reached Substantial Completion of Erosion Control, the Contractor shall keep all seeded areas stabilized at all times. Any damage to seeded areas or to mulch materials shall be promptly repaired.
- (ii) All inspection sediment removal, and BMP maintenance activities to comply with all Federal, State & Local erosion control permit requirements until Final Stabilization is reached.
- (iii) All removal and replacement of existing BMPs due to damage to same suffered either by the contractor, outside agencies, the public, or acts of God.
- (iv) All required mechanical and/ or manual street sweeping.
- (v) Discretionary changes required of any regulatory enforcement officer.

If the Contractor fails to maintain the BMPs in accordance with the Contract, or as directed, the City may at the expiration of a period of 48 hours, after having given the Contractor written notice, proceed to maintain BMPs as deemed necessary. The cost thereof will be deducted from any compensation due, or which may become due to the Contractor under this Contract.

I) MINOR SWMP MODIFICATIONS: Shall be made in the field by the Contractor and thoroughly documented in the Contractor's SWMP narrative and drawings. Should the Permit Enforcement Authority deem minor field modifications inadequate, the Contractor may be required to a) make specific modifications as requested by the Permit Enforcement Authority or b) return to the original approved design specifications. Minor SWMP Modifications are allowed, covered under the original CASDP, and required as part of standard maintenance and operation.

J) MAJOR SWMP MODIFICATION: The City reserves the right to require changes in the Work or Project Limits that may require a Major Modification to the SWMP and/ or CASDP due to unforeseen circumstances. Should this occur, the Contractor will be responsible for the following (as applicable) and applying for CASDP amendment:

- (i) Make required revisions to comply with changing Federal or State rulemaking if it occurs within timeframe of the Project
- (ii) Make required revisions due to unforeseen or unplanned conditions leading to deficient Drawings/SWMP (hazardous materials encountered, landfills, expansion of work limits, etc.)
- (iii) Prepare revised SWMP elements endorsed by a Professional Engineer licensed in the State of Colorado.

-10-

**REVISION OF SECTION 208
EROSION CONTROL**

K) SUBSTANTIAL COMPLETION OF EROSION CONTROL: When a CASDP is required for the Project, Substantial Completion of the Project as defined by the City and County of Denver General Contract Conditions cannot be reached until Substantial Completion of Erosion Control has been granted. Granting of Substantial Completion of Erosion Control must be requested by the Contractor and be approved by the Permit Enforcement Authority in the form of a “Certificate of Substantial Completion of Erosion Control”.

L) FINAL STABILIZATION: Granting of Final Stabilization must be requested by the Contractor and be approved by the Permit Enforcement Authority. Other permanent soil stabilization techniques may be proposed, in writing, by the Contractor and used upon approval, in writing, by the Project Manager and Permit Enforcement Authority.

The Contractor shall follow the following procedures for approval of Final Stabilization:

- (i) The Contractor shall file Inactivation Request for Construction Activities Stormwater Discharge Permit (available within CASDP guidance documents) with the Permit Enforcement Authority.
- (ii) The Contractor shall coordinate with the Permit Enforcement Authority to hold a Final Inactivation Inspection.
- (iii) If passing, the Permit Enforcement Authority transmits a letter of approval for Final Stabilization.
- (iv) If not passing, the Permit Enforcement Authority transmits a letter of denial for Final Stabilization with associated inspection report to Contractor.
- (v) Stabilization, inspection and maintenance requirements shall continue until confirmation of having met final closure requirements have been granted in writing by the Permit Enforcement Authority.

When Final Stabilization has been reached, the Permit Enforcement Authority shall issue a “Certificate of Final Stabilization”.

- (vi) Once the Inactivation request is approved by the City and County of Denver, the contractor can apply to close the State Stormwater Permit.

M) FINAL ACCEPTANCE:

CASDP obligations (including reaching Final Stabilization) may hinder the ability to reach Final Acceptance for the overall Project as defined in the City General Contract Conditions.

PART VI: CONSTRUCTION OF BMPs

BMPs shall be constructed so that they conform to all requirements as set forth within the Project SWMP. They shall meet all requirements set forth within each BMP detail and shall be installed and maintained so that they function in an effective and operable manner.

PART VII: METHOD OF MEASUREMENT

Contract Control No. 2021-PROJMSTR-0000693

May 24, 2022

No separate measurement will be made for the services or materials required to install, maintain, supervise or inspect erosion control devices as shown on the plans or in accordance with this specification.

Removal and disposal of sediment, concrete & trash that is or is not generated by construction activities, will not be measured separately but shall be included in the work.

-11-
**REVISION OF SECTION 208
 EROSION CONTROL**

Any excavation required for the removal of sediment from traps, basins, areas adjacent to silt fences and erosion bales, and any other cleanout excavation of accumulated sediment, and removal of check dams or storm drain inlet protection will not be measured separately but shall be included in the work.

PART VIII: BASIS OF PAYMENT

Work to furnish, install, maintain, supervise, inspect, replace (if not due to contractor negligence), remove, and dispose of BMPs specified in the Contract will be not be paid for separately but shall be paid for at the Contract bid lump sum price.

Payment will be made under:

| Pay Item | Pay Unit |
|-----------------|-----------------|
| Erosion Control | Lump Sum |

Payment will be full compensation for all work, materials and equipment required to furnish, install, maintain, supervise, inspect, remove, and dispose of BMP's. BMPs as deployed per the SWMP requiring replacement due to Contractor negligence and or carelessness shall be provided at the Contactor's expense.

Temporary BMPs required due to the Contractor's negligence, carelessness, or failure to install permanent controls as a part of the work as scheduled or for the Contractor's convenience, shall be performed at the Contractor's expense.

If the Contractor fails to complete construction within the approved contract time, no additional payment will be made for Section 208 for the period of time after expiration of the approved contract time. These items shall be provided at the Contractor's expense.

The cost for any corrective actions required by the State or City due to contractor's failure to obtain or comply with applicable Permits will be borne by the Contractor, including fines and penalties. In the case of failures on the part of the Contractor in controlling erosion, sedimentation, and/or water pollution, the City may provide the necessary corrective actions. All corrective action costs, including Project engineering costs, will be charged to the Contractor, and appropriate deduction will be made from the Contractor's monthly pay estimate.

The Contractor however may submit a separate itemized Change Order for any required Major SWMP Modification proposed by the City during the course of the Project.

Erosion Control ~~Supervisor~~ shall include all materials, labor and equipment necessary for the ECS to perform the work. Commute time shall be included in the work. ECS shall include all labor, Professional Engineering (includes supervisory Professional Engineer licensed in the State of Colorado), and/ or design fees to prepare modifications to Stormwater Management Plan(s), revise or amend Permits, coordinate with State and Local agencies, design special erosion control plans for emergency situations that develop during construction or unexpected weather conditions.

Contract Control No. 2021-PROJMSTR-0000693

May 24, 2022

No additional payment will be made for multiple stabilized construction/ staging areas proposed by the Contractor.

Concrete washout structure, whether constructed or prefabricated, includes all work and materials required to install, maintain, and remove the item. This includes, but is not limited to: excavation, embankment, liner, erosion bales, fencing, signing, and containment and disposal of concrete washout and all other associated waste material.

Silt berm spikes and dike staples shall be included in the work

-12-

**REVISION OF SECTION 208
EROSION CONTROL**

Storm drain inlet protection includes all work, materials, and equipment required to complete the item, including surface preparation, maintenance throughout the Project, and removal upon completion of the work.

Sweeping, when used as a BMP as shown in the Contract, will be a pickup broom or motorized equipment capable of collecting sediment, authorized by the Project Manager, used to remove sediment from the roadway or other paved surfaces. Operator costs shall be included in the work.

Stakes, anchors, connections, geotextile, riprap and tie downs used for temporary slope drains shall be included in the work.

Vehicle tracking pad includes all work, materials and equipment required to construct, maintain, and remove the entrance upon completion of the work. Aggregate and geotextile shall be included in the work.

Surveying of permanent BMPs shall be included in the work.

END OF SECTION

**REVISION OF SECTION 213
MULCHING
DESCRIPTION**

Section 213 of the Standard Specifications is hereby revised for this project as follows:

Subsection 213.01 shall include the following:

213.01 This work consists of furnishing and placing shredded wood mulch in the planting beds in accordance with the details shown on the plans.

MATERIALS

Subsection 213.02(d) shall include the following:

Wood chip mulch shall be shredded Western Red Cedar (Gorilla Hair Mulch). Contractor shall submit a 0.5 cubic foot sample for approval prior to ordering.

Subsection 213.02 shall include the following:

Pesticides:

- a. Pesticide registered with the EPA, acceptable to authorities having jurisdiction and type recommended by manufacturer for specific problem and as required for project conditions.
- b. Pre Emergent herbicide for controlling the germination and growth of weeds within aggregate surface areas at the base course level of the aggregate layer.

Subsection 213.03(e) is hereby revised as follows:

(e) Shredded Wood Mulch. A 3-inch layer, unless otherwise shown in the plans, of wood chip mulch shall be uniformly applied to all planting beds as shown on the plans or as directed. Wood chip mulch shall be placed in all planting beds and SSP's. Wood chip mulch shall be capable of matting together to resist scattering by the wind. Do not place mulch against stems of plants and keep four inches (4") away from tree trunk.

Install pesticides prior to woodchip mulch installation.

Subsection 213.05 shall include the following:

| Pay Item | Pay Unit |
|----------------------------|--------------------------|
| <u>Mulching Wood Mulch</u> | <u>Square-Cubic</u> Foot |

END OF SECTION

Contract Control No. 2021-PROJMSTR-0000693

May 24, 2022

-7-
**REVISION OF SECTION 214
 PLANTING**

METHOD OF MEASUREMENT

214.05 The quantity of planting to be measured will be the number of plants, of the types and sizes designated in the Contract that are actually planted and accepted.

Landscape Maintenance will not be measured but will be paid for on a lump sum basis.

BASIS OF PAYMENT

214.06 The accepted quantities of planting, and brush layer cuttings will be paid for at the contract unit price for each of the various items listed below that appear in the bid schedule.

Payment for the total cost of the item will be made at the completion of planting. Cost of the performance bond shall be included in the cost of the plant items.

Payment will be made under:

| Pay Item | Pay Unit |
|--|-----------------|
| Deciduous Tree (2-5 3 Inch Caliper) | Each |
| Deciduous Shrub (2 4 Gallon Container) | Each |
| <u>Deciduous Shrub (5 Gallon Container)</u> | <u>Each</u> |
| Perennials (1 Gallon Container) | Each |
| Ornamental Grasses (1 Gallon Container) | Each |
| 1 Year Landscape Maintenance | Lump Sum |

Water required for all items of work will not be measured and paid for separately, but shall be included in the work.

Payment shall be full compensation for all work necessary to complete the item.

For each month that landscape maintenance is performed and accepted during the Landscape Maintenance period as specified in subsection 214.04, payment for Landscape maintenance will be made in installments as follows:

- (1) 10 percent of the lump sum amount will be paid for each of the eight growing season months, March through October.
- (2) 5 percent of the lump sum amount will be paid for each of the winter months, November through February.

Landscape maintenance performed during construction will not be measured and paid for separately, but shall be included in the work.

Landscape Establishment, except for landscape maintenance, will not be paid for separately, but shall be included in the work.

END OF SECTION

-4-

**REVISION OF SECTION 250
ENVIRONMENTAL HEALTH AND SAFETY MANAGEMENT**

The CABI must have sufficient experience to identify historical urban fill and RACS in the field. Depending on the project schedule, a minimum of one CABI will be overseeing excavation work, and it may be necessary to engage multiple CABIs if areas of known historical fill or debris are identified at multiple excavation areas. The basis of payment for the CABI is on an hourly basis. The Contractor should expect that the CABI will be on site 100% of the time during soil-disturbing activities should suspect materials, debris, construction and demolition debris, HUF, or other suspected materials are encountered. When the Contractor is working in “clean” soil – that is, soil that does not contain debris, the CABI is not required to be present. See the RACS SOP for detailed information regarding the CABI’s responsibilities. Costs should include all associated expenses to carry out the work.

The Contractor is permitted (and encouraged) to retain a CABI that can fill the role of the MMP Supervisor concurrently, as this would be a cost-saving measure.

The CABI will be paid under the pay item “Certified Asbestos Building Inspector” and will be measured on an hourly basis.

Asbestos and Chemistry Analytical Costs

If required, to evaluate chemical characteristics in soil and/or groundwater samples, or asbestos content in suspect materials, soil and/or suspect material samples shall be analyzed by a NELAC- (or equivalent) certified laboratory. The Contractor should include costs for up to 5 chemical samples, and 20 asbestos samples.

Analytical costs will be paid for under the “Material Sampling and Delivery – Chemical” and Material Sampling and Delivery – Asbestos” and will be measured by each unit based on quoted laboratory rates for the required analysis.

Solid Waste Excavation, Loading, and Transportation

Materials as described in the MMP that are not considered hazardous waste, may be transported and disposed as non-hazardous solid waste to the Denver-Arapahoe Disposal Site. Tipping fees associated with disposal at the Denver-Arapahoe Disposal Site will be paid for separately by the Owner. The Owner will work to establish a Waste Profile and will supply the Contractor with Waste Manifests that must accompany each load destined to DADS.

Solid waste excavation, loading, and transportation will be paid for under the pay item “Solid Waste Excavation, Loading, and Transportation” and will be measured by on a cubic-yard basis and shall include providing any additional soil required above the excess material generated by the project. –

-4-

**REVISION OF SECTION 412 AND 608
PAVEMENT, SIDEWALKS , CURB RAMPS, AND BIKEWAYS**

Vertical concrete forms shall be maintained until concrete has cured prior to form removal at the discretion of the Engineer.

- (g) *Finishing.* Review drawings to gain full understanding of the different finishing techniques prescribed.

Broom Finish for bikeway shall be medium broom finish applied in perpendicular to flow of traffic or 90 degrees to back of curb. Broom finish for sidewalk shall be medium broom finish perpendicular or 90 degrees to direction of traffic.

- (h) *Steel Reinforcing.* Refer to Section 601 for all reinforcing steel requirements.

- (i) *Directional Warning Tiles.* Tiles shall be installed between intersections to direct sight impaired persons to stay in the designated walk areas. Tiles shall be installed continuously as shown on the plans.

Subsection 608.06 shall include the following:

| Pay Item | Pay Unit |
|---|-----------------|
| Concrete Pavement (6") (Colored) | Square Yard |
| Detectable Directional Warning Tiles | Linear Foot |
| Truncated Domes Detectable Warning Surface (Cast Iron) | Square Foot |
| Detectable Warning Surface Truncated Domes | Square Foot |

All work necessary and incidental to the construction of sidewalks and bikeways, will not be measured and paid for separately but shall be included in the work.

REVISION OF SECTION 412

Section 412 of the Standard Specifications is hereby revised for this project as follows:

Subsection 412.02 shall include the following:

Colors for concrete pavement shall be as noted above in revision to subsection 608.02

Subsection 412.13 shall include the following:

Dowel bars required for concrete pavement, including curbs or tying into existing pavement, shall be as defined in the City of Denver Transportation Standards and Details for the Engineering Division Dwg 11.0-11.9.

Contractor shall submit jointing plans for approval 10 days prior to commencing paving.

END OF SECTION

Contract Control No. 2021-PROJMSTR-0000693

May 24, 2022

**REVISION OF SECTION 613
LIGHTING**

Section 613 of the Standard Specifications is hereby revised for this project as follows:

Subsection 613.02 shall include the following:

Installation shall conform to the City of Denver Street Lighting Design and Xcel Energy Guidelines.

The Contractor shall furnish and install LED luminaires on traffic signal poles in accordance with City of Denver standards at the locations shown on the plans.

The Contractor shall coordinate install of Xcel designed and installed LED Street Lights Luminaire, Bridge underdeck lighs, and Pedestrian Lights ~~pedestrian~~ at locations as shown on the plans with Xcel Energy ~~and install the required conduit and foundations. The LED Street Light Luminaire shall be compatible or interchangeable with standard LED Street Light Luminaire as stocked by Xcel Energy.~~

Luminaires shall be of the following types as noted on the Fixture Schedule in the plans:

| <u>Manufacturer</u> | <u>Catalog Series</u> | <u>Description</u> |
|---------------------|---|---------------------------|
| Kim Lighting | Ouro (LED 3000k 3000 Lumens) | P1 or P2 Pedestrian Light |
| GE Evolve | ERL1 Cobrahead (LED, 3000k, 4900 Lumens) | P3 Street Light |
| Cooper Lighting | UFLD-S (LED, 3000k, 3000 lumens) | U1 Underdeck Light |
| <u>GE Evolve</u> | <u>ERL-HH-016-B3-30-A-6012-035 (LED, 3000k)</u> | <u>Traffic Signals</u> |

The luminaire shall also include a 7-pin photo cell (S-T P124-1.5-PTW or equal). Luminaire finish:

Street Light:

Color: Black or approved by CCD and Xcel

Pedestrian Light:

Color: Black or approved by CCD and Xcel

Underdeck Light:

Color: Black or approved by CCD and Xcel

Traffic Signal:

Color: Federal Green or approved by CCD.

For traffic signals, the Contractor shall submit a lighting materials list to the City and Denver for approval prior to ordering. Contact Matt Blessinger at 720-865-4066.

Subsection 613.04 shall include the following:

Pedestrian lights installed on the bridge approach slab shall have the anchor bolts and conduit installed during the approach slab and sidewalk construction in accordance with the plans.

Subsection 613.08 shall include the following:

For traffic signal light poles at least one grounding electrode shall be installed adjacent to each. Wiring shall be a 120/240 volt or 120/208 volt, 3-wire system with individual luminaire wired for 120 volts.

Wiring for street lights, pedestrian lights and underdeck lights shall be coordinated with Xcel.

-2-

**REVISION OF SECTION 613
LIGHTING**

Subsection 613.14 shall include the following luminaire, pole and foundation:

| Pay Item | Pay Unit |
|--|-----------------|
| P3 Street Luminaire/Pole/Foundation | Each |
| P1 Pedestrian Luminaire/Pole/Foundation | Each |
| P2 Pedestrian Luminaire/Pole/Foundation | Each |
| U1 Under Bridge Lighting | Each |
| Luminaire (LED)(15300 Lumens)(55 Watt) | Each |

Pedestrian light foundation on the approach slab will be paid for per the applicable type listed above.

Traffic Signal Luminaire shall be measured and paid by the number of luminaires installed. The item shall include all labor, materials, and ancillary hardware required to provide a fully-functional system to the satisfaction of the Engineer.

END OF SECTION

**REVISION OF SECTION 635
SITE FURNISHINGS**

Section 635 of the Standard Specifications is hereby revised as follows:

635.01 DESCRIPTION

Provide, install and warranty site improvements and furnishings complete as shown on the drawings and as specified herein. Work of this Section includes benches, bike racks and trash receptacles.

QUALITY ASSURANCE

A. Applicable Standards: Apply the current or latest editions of the standards described below:

ACI - American Concrete Institute, Manual for Concrete Practice.

ASTM - American Society for Testing and Materials

UBC - Uniform Building Code

CPSC – U.S. Consumer Product Safety Commission

City and County of Denver: Streetscape Guidelines and Public Works requirements with respect to work in the public Right of Way.

B. Compatibility with Adjacent Materials: Verify that all site furnishings are coordinated with other site improvements either completed or planned, and that installation shall not adversely affect other site improvements.

C. Qualifications:

1. Installer of site furnishings shall demonstrate successful continuous experience in site work furnishing fabrication and installations similar to the work of this project for a period of not less than five (5) years.
2. Installer Qualifications: An experienced installer who has completed Work similar in material, design, and extent to that indicated for this Project and whose work has resulted in construction with a record of successful in-service performance.
3. Material Certificates: Signed by manufacturers certifying that each of the following items complies with requirements: Anti-graffiti Sealant.
4. Professional Engineer for review of all structural elements as required shall be a professional engineer who is legally qualified to practice in jurisdiction where the Project is located (Colorado) and shall be experienced in providing engineering services of the type indicated. Engineering services are defined as those performed for final design of structural foundations for concrete planter.

SUBMITTALS

A. Samples and Product Data: Submit samples and/or manufacturer's current literature for the specified items including:

1. Catalog cuts and actual color/finish samples for each type of furnishing and anti-graffiti sealant.
2. Dimensioned drawings showing proposed installation method for each piece furnished.

**REVISION OF SECTION 708
ANTI-GRAFFITI COATING**

Section 708 of the Standard Specifications is hereby revised for this project as follows:

Subsection 708 shall also include the following:

This specification covers anti-graffiti coatings, which are coatings applied to substrates to facilitate the removal of graffiti.

MATERIALS

General:

(1) Anti-graffiti coatings must not react deleteriously with above-grade concrete, concrete block, exposed aggregate concrete, brick, stonework, painted steel, or aluminum substrates.

(2) The applied coating must produce a firm, clear, continuous, uniform film that is free of pinholes, cracks, or other film defects and exhibit satisfactory adhesion. The consistency must be such that the coating can be satisfactorily applied by spray, roller, or brush at atmospheric and material temperatures above 50°F without thinning. When applied properly to vertical surfaces, the coating must remain uniform during the required curing period and must not sag, disintegrate, check, peel, or crack.

(3) The VOC content of the coating must comply with the current national rule for industrial maintenance coatings.

(4) When the Contract Documents specify the coating as clear or translucent, the coating must cure clear or translucent, as appropriate. The use of graffiti removers, solvents, or both must not cause damage or pigment loss. The color must be clear or translucent. Provide material complying with the requirements listed in the table below:

| REQUIREMENTS FOR PERMANENT, WATER-CLEANABLE COATING | | |
|--|--------------------|----------------------|
| Property | Test Method | Requirement |
| Graffiti resistance | ASTM D7089 | Cleanability Level 1 |
| Recleanability | ASTM D 7089 | Min. 10 cycles |
| Set to Touch | ASTM D 1640* | 4 hr. maximum |
| Dry Through Time | ASTM D 1640* | 24 hr. maximum |

*3 mil wet film tested at 77 degrees F.

Coating shall allow for the removal of the graffiti with a high-pressure cold water wash. Coatings must be self-recoatable for the life of the coating.

Submit a one-gallon sample for approval. Failure of the material to function appropriately in the field will be cause for removal of the product and re-application with approved product and any repair to existing surfaces at no cost to the owner.

CONSTRUCTION REQUIREMENTS

Apply according to manufacturer's recommendations.

END OF SECTION

Contract Control No. 2021-PROJMSTR-0000693

May 24, 2022

FORCE ACCOUNT ITEMS**DESCRIPTION**

This special provision contains the City and County's estimate for force account items included in the Contract. Force account work shall be performed as directed by the Engineer.

BASIS OF PAYMENT

Contractor shall request written approval for expenditure of any contract allowance PRIOR TO performing the Work involved. List of Work to be performed and estimated cost shall be in the requesting correspondence.

Using the format provided by the City, the Contractors request for payment of all contract allowances shall be included in the Schedule of Values.

Payment will be made in accordance with the provision of General Condition Title 11. Payment will constitute full compensation for all work necessary to complete the item.

Force account work valued at \$5,000 or less, that must be performed by a licensed journeyman in order to comply with federal, state, or local codes, may be paid for after receipt of an itemized statement endorsed by the Contractor.

| <u>Item No.</u> | <u>Allowance Item</u> | <u>Quantity</u> | <u>Estimated Amount</u> |
|------------------------|--|------------------------|--------------------------------|
| 700-70010 | Minor Contract Revisions | F/A | \$100,000.00 |
| 700-70072 | Obtain Power from Xcel | F/A | \$ 50,000.00 |
| 700-70175 | Unknown Utilities | F/A | \$ 25,000.00 |
| <u>700-70210</u> | <u>Lighting</u> | <u>F/A</u> | <u>\$100,000.00</u> |
| 700-70236 | Permits | F/A | \$ 25,000.00 |
| 700-70245 | Utility Tap Fee | F/A | \$ 25,000.00 |
| 700-70305 | Aesthetics | F/A | \$500,000.00 |
| 700-70380 | Erosion Control | F/A | \$ 50,000.00 |
| 700-70581 | Air Monitoring Specialist | F/A | \$ 15,000.00 |
| 700-70588 | RACS Excavation, Loading, and Transportation | F/A | \$ 50,000.00 |

F/A Minor Contract Revisions shall be used at the Engineers direction for unforeseen conditions encountered during construction.

F/A Obtain Power from Xcel shall be used to cover costs associated providing a new meter pedestal and service if needed for the irrigation system. Pending Xcel design and CCD maintenance agreement.

F/A Unknown Utilities shall be used to cover costs associated with utilities that were not discovered during design but are found during construction and need to be adjusted to facilitate construction.

F/A Lighting shall be used to cover costs associated with lighting construction by Xcel.

F/A Permits shall be used for any unexpected permits beyond those identified in the bid documents.

F/A Utility Taps shall be used for any tap fees that will be required to complete project work.

F/A Aesthetics shall be used to incorporate any Engineer requested bridge or other architectural or aesthetic enhancements.

F/A Erosion Control shall be used for any unexpected erosion control measures required through coordination between projects or due to a change in conditions encountered during the course of the work.

F/A - Air Monitoring Specialist and **F/A - RACS Excavation, Loading, and Transportation** shall be as defined in Revision to Section 250.

END OF SECTION

CONNECTING AURARIA - ADDENDUM #1
ATTACHMENT 2 - Revisions to Drawings
PLAN SHEET REVISIONS

| <u>SHEET</u> | <u>REVISION</u> |
|------------------|---|
| 8-9 | SOAQ UPDATES |
| 16, 18 | REMOVAL CLARIFICATIONS |
| 20-22 | ROADWAY CLARIFICATIONS |
| 53-54, 68, 75-76 | CLASS G CONCRETE CHANGED TO CLASS D |
| 55 | STREET NAME SIGNS ADDED |
| 83-84 | DRAINAGE REMOVAL UPDATES |
| 108 | MONUMENT PAY ITEMS ADDED |
| 139, 144 | LIGHTING UPDATES FOR LUMP SUM |
| 145-147 | UTILITY REPRINT FOR CLARITY |
| 168 | SIGNAL PLAN ELECTRIC METER PEDESTAL AND BASE UPDATE |
| 171 | TRAFFIC CONTROL UPDATED FOR LUMP SUM |
| 181 | SWMP UPDATED FOR LUMP SUM |
| 190 | CONSTRUCTION MAT CLARIFICATION |

| Item | Description | Units | Plan | Final |
|------------|--|-------|-------|-------|
| 201-00001 | CLEARING AND GRUBBING | LS | 1 | |
| 202-00001 | REMOVAL OF STRUCTURE | EACH | 1 | |
| 202 | REMOVAL OF TREE GRATE | EACH | 4 | |
| 202 | REMOVAL OF BANNER POLE | EACH | 17 | |
| 202 | REMOVAL OF BIKE RACK | EACH | 7 | |
| 202 | REMOVAL OF PLANTER POT | EACH | 20 | |
| 202 | REMOVAL OF TRASH RECEPTICAL | EACH | 2 | |
| 202 | REMOVAL OF BENCH | EACH | 2 | |
| 202 | REMOVAL OF DELINEATOR | EACH | 11 | |
| 202 | REMOVAL OF DECORATIVE CROSSWALKS (PAINTED BRICK PATTERN) | SF | 1,268 | |
| 202 | REMOVAL OF PRE CAST MEDIANS | LS | 1 | |
| 202-00010 | REMOVAL OF TREE | EACH | 1 | |
| 202-00019 | REMOVAL OF INLET | EACH | 5 | |
| 202-00035 | REMOVAL OF PIPE | LF | 118 | |
| 202-00175 | REMOVAL OF CONCRETE DRIVEWAY | SY | 125 | |
| 202-00200 | REMOVAL OF CONCRETE SIDEWALK | SY | 1,032 | |
| 202-00203 | REMOVAL OF CURB AND GUTTER | LF | 868 | |
| 202-00206 | REMOVAL OF CONCRETE CURB RAMP | SY | 115 | |
| 202-00210 | REMOVAL OF CONCRETE PAVEMENT | SY | 1,789 | |
| 202-00220 | REMOVAL OF ASPHALT MAT | SY | 812 | |
| 202-00250 | REMOVAL OF PAVEMENT MARKING | SF | 909 | |
| 202-00810 | REMOVAL OF GROUND SIGN | EACH | 7 | |
| 202-00821 | REMOVAL OF SIGN PANEL | EACH | 21 | |
| 202-00828 | REMOVAL OF TRAFFIC SIGNAL EQUIPMENT | LS | 1 | |
| 202-010000 | REMOVAL OF FENCE | LF | 7 | |
| 202-04005 | CLEAN VALVE BOX | EACH | 2 | |
| 203-00010 | UNCLASSIFIED EXCAVATION(COMPLETE IN PLACE) | CY | 434 | |
| 203-01597 | POTHOLING | HR | 300 | |
| 206-00000 | STRUCTURE EXCAVATION | CY | 485 | |
| 206-00100 | STRUCTURE BACKFILL (CLASS I) | CY | 309 | |
| 206-00200 | STRUCTURE BACKFILL (CLASS 2) | CY | 70 | |
| 206-00360 | MECHANICAL REINFORCEMENT OF SOIL | CY | 309 | |
| 206-01781 | SHORING (Area 1) | LS | 1 | |
| 208 | WATER CONTROL | LS | 1 | |
| 208-00200 | EROSION CONTROL | LS | 1 | |
| 208-00013 | EROSION CONTROL LOG (TYPE I) | LF | 6 | |
| 208-00035 | AGGREGATE BAG | LF | 240 | |
| 208-00045 | CONCRETE WASHOUT STRUCTURE | EACH | 2 | |
| 208-00053 | INLET PROTECTION (TYPE I) | EACH | 14 | |
| 208-00054 | INLET PROTECTION (TYPE II) | EACH | 2 | |
| 208-00070 | VEHICLE TRACKING PAD | EACH | 2 | |
| 210 | RESET PRE CAST MEDIANS | LS | 1 | |
| 210 | RESET TRASH RECEPTACLE | EACH | 2 | |
| 210-00827 | RESET PULL BOX | EACH | 4 | |
| 210-00831 | RESET TRAFFIC SIGNAL HEAD | EACH | 2 | |
| 210-00842 | RESET TRAFFIC SIGNAL MAST ARM | EACH | 1 | |
| 210-04010 | ADJUST MANHOLE | EACH | 1 | |
| 210-04050 | ADJUST VALVE BOX | EACH | 2 | |
| 212-00101 | TREE PROTECTION | EACH | 9- 12 | |
| 212-00005 | SEEDING (NATIVE) | ACRE | 0.05 | |
| 212-01200 | LANDSCAPE RESTORATION | LS | 1 | |
| 213-00000 | MULCHING | ACRE | 0.05 | |

| Item | Description | Units | Plan | Final |
|-----------|--|-------|---------------|-------|
| 213 | WOOD MULCH | CF | 475 | |
| 214-00000 | 1 YEAR LANDSCAPE MAINTENANCE | LS | 1.00 | |
| 214-00230 | DECIDUOUS TREE (3 INCH CALIPER) | EACH | 9 | |
| 214-00320 | DECIDUOUS SHRUB (2 GALLON CONTAINER) | EACH | 187 | |
| 214-00350 | DECIDUOUS SHRUB (5 GALLON CONTAINER) | EACH | 65 | |
| 214-00910 | PERENNIALS (1 GALLON CONTAINER) | EACH | 448 | |
| 250-00010 | ENVIRONMENTAL HEALTH AND SAFETY MANAGEMENT | LS | 1 | |
| 250-00110 | HEALTH AND SAFETY OFFICER | HR | 20 | |
| 250 | MATERIAL SAMPLING AND DELIVERY-CHEMICAL | EACH | 5 | |
| 250 | MATERIAL SAMPLING AND DELIVERY-ASBESTOS | EACH | 20 | |
| 250 | MATERIALS MANAGEMENT PLAN SUPERVISOR | HR | 80 | |
| 250 | CERTIFIED ASBESTOS BUILDING INSPECTOR | HR | 80 | |
| 250 | ASBESTOS CONTAINING MATERIAL ABATEMENT | CY LS | 7- 1 | |
| 250 | SOLID WASTE EXCAVATION AND TRANSPORTING | CY | 230 | |
| 250 | BRIDGE PRE-DEMOLITION ASBESTOS INSPECTION | LS | 1 | |
| 304-06007 | AGGREGATE BASE COURSE (CLASS 6) | CY | 391 | |
| 403-00721 | HOT MIX ASPHALT (PATCHING) (ASPHALT) | SY | 818 18 | |
| 412-00600 | CONCRETE PAVEMENT (6 INCH) | SY | 595 | |
| 412 | CONCRETE PAVEMENT (6 INCH) (COLORED) | SY | 761 | |
| 412-00800 | CONCRETE PAVEMENT (8 INCH) | SY | 973 | |
| 412 | CONCRETE PAVEMENT (8 INCH) (COLORED) | SY | 914 | |
| 502-00100 | DRILLING HOLE TO FACILITATE PILE DRIVING | LF | 224 | |
| 502-11274 | STEEL PILING (HP 12X74) | LF | 445 | |
| 503-00024 | DRILLED SHAFT (24 INCH) | LF | 28 | |
| 503-00036 | DRILLED SHAFT (36 INCH) | LF | 52 | |
| 504 | CONCRETE PLANTER WALL | LF | 189 | |
| 504 | WATER QUALITY PLANTER WALL | LF | 170 | |
| 506-00212 | RIPRAP (12 INCH) | CY | 14 | |
| 509-00000 | STRUCTURAL STEEL | LB | 42 | |
| 514-99999 | FENCE (SPECIAL)(6-18 INCH) | LF | 81 | |
| 515-00400 | CONCRETE SEALER | SY | 566 | |
| 519-03035 | PLACE THIN BONDED OVERLAY (POLYESTER CONCRETE) | SY | 363 | |
| 519-03055 | FURNISH THIN BONDED OVERLAY (POLYESTER CONCRETE) | CF | 205 | |
| 601-03040 | CONCRETE CLASS D (BRIDGE) | CY | 372 | |
| 601-04550 | CONCRETE CLASS G | CY | 366 | |
| 601-40300 | STRUCTURAL CONCRETE COATING | SY | 313 | |
| 601-40302 | STRUCTURAL CONCRETE COATING (ANTI-GRAFFITI) | SF | 699 | |
| 602-00020 | REINFORCING STEEL (EPOXY COATED) | LB | 44,343 44,748 | |
| 603-01155 | 15 INCH REINFORCED CONCRETE PIPE (CIP) | LF | 54 | |
| 604-13005 | INLET TYPE 13 (5 FOOT) | EACH | 1 | |
| 604-13505 | INLET TYPE 13 (DOUBLE) (5 FOOT) | EACH | 1 | |
| 604-19110 | INLET TYPE L 5 (10 FOOT) | EACH | 1 | |
| 605 | CONCRETE COLLAR | EACH | 1 | |
| 606-11035 | BRIDGE RAIL TYPE 10 MASH | LF | 213 | |
| 607-11580 | TEMPORARY FENCE | LF | 800 | |
| 608 | DETECTABLE DIRECTIONAL WARNING TILES | LF | 609 | |
| 608-00010 | CONCRETE CURB RAMP | SY | 288 | |
| 608 | DETECTABLE WARNING SURFACE | SF | 150 | |
| 608 | DETECTABLE WARNING SURFACE (CAST IRON) | SF | 227 | |
| 609-20010 | CURB AND GUTTER TYPE 2 (SECTION B) | LF | 37 | |
| 609-21010 | CURB AND GUTTER TYPE 2 (SECTION I-B) | LF | 77 | |

C:\wip\p\0456241\Connecting_Auraria_SDAQ.dwg

Print Date: 5/18/2022
 File Name: Connecting_Auraria_SDAQ.dwg
 Horiz. Scale: Vert. Scale: As Noted



990 S Broadway, Suite 220
 Denver, CO 80209
 (303) 297-2976 main
 (303) 297-2693 fax
 www.wilsonco.com

| Sheet Revisions | | |
|-----------------|-------------|-------|
| Date: | Comments | Init. |
| 6/28/22 | ADDENDUM #1 | DH |
| | | |
| | | |



DEPARTMENT OF TRANSPORTATION & INFRASTRUCTURE
 201 WEST COLFAX AVENUE
 DENVER, CO 80202
 PHONE: (720) 913-4501
 FAX: (720) 913-4544

| As Constructed | CONNECTING AURARIA | |
|----------------|-------------------------------|-----------------------|
| No Revisions: | SUMMARY OF APPROX. QUANTITIES | |
| Revised: | Designer: KPM | Structure Numbers |
| Void: | Detailer: KPM | Sheet Subset: SOAQ |
| | | Subset Sheets: 1 of 2 |

Project No./Code

Sheet Number **8**

| Item | Description | Units | Plan | Final |
|-----------|--|-------|-------|-------|
| 609-21020 | CURB AND GUTTER TYPE 2 (SECTION II-B) | LF | 316 | |
| 609-71000 | CURB (SPECIAL) | LF | 200 | |
| 612-00039 | DELINEATOR (FLEXIBLE) (SURFACE MOUNTED) | EACH | 34 | |
| 612 | PRECAST CONCRETE MEDIAN | EACH | 25 | |
| 613-00100 | 1 INCH ELECTRICAL CONDUIT | LF | 144 | |
| 613-00100 | 1 INCH ELECTRICAL CONDUIT (PVC) | LF | 100 | |
| 613-00102 | 1 INCH ELECTRICAL CONDUIT (GALVANIZED RIGID CONDUIT) (SPECIAL) | LF | 100 | |
| 613-00200 | 2 INCH ELECTRICAL CONDUIT | LF | 802 | |
| 613-00300 | 3 INCH ELECTRICAL CONDUIT | LF | 1,002 | |
| 613 | INTERCONNECT 3-INCH ELECTRICAL CONDUIT | LF | 289 | |
| 613 | PULL BOX TYPE B (TRAFFIC) | EACH | 9 | |
| 613 | PULL BOX TYPE C (TRAFFIC COMM) | EACH | 3 | |
| 613-07000 | PULL BOX (SPECIAL) | EACH | 1 | |
| 613-07010 | PULL BOX (SURFACE MOUNTED) | EACH | 2 | |
| 613-10000 | WIRING | LS | 1 | |
| 613 | LUMINAIRE (LED) (5300 LUMENS) (55 WATT) | EACH | 8 | |
| 613-15000 | FLOODLIGHT | EACH | 4 | |
| 613-30005 | LIGHT STANDARD AND LUMINAIRE (PEDESTRIAN) | EACH | 12 | |
| 613-34250 | LIGHT STANDARD-METAL (25 FOOT) | EACH | 1 | |
| 613-50109 | ELECTRIC METER PEDESTAL CABINET AND BASE | EACH | 1 | |
| 614-00011 | SIGN PANEL (CLASS I) | SF | 150 | |
| 614-00012 | SIGN PANEL (CLASS II) | SF | 51 | |
| 614-00216 | STEEL SIGNPOST (2X2 INCH TUBING) | LF | 47 | |
| 614-70117 | PEDESTRIAN SIGNAL FACE (16) | EACH | 16 | |
| 614-70324 | TRAFFIC SIGNAL FACE (8-8-8) | EACH | 4 | |
| 614-70336 | TRAFFIC SIGNAL FACE (12-12-12) | EACH | 19 | |
| 614-72855 | TRAFFIC SIGNAL CONTROLLER CABINET | EACH | 2 | |
| 614-81000 | TRAFFIC SIGNAL-LIGHT POLE STEEL | EACH | 4 | |
| 614-81120 | TRAFFIC SIGNAL-LIGHT POLE STEEL (1-20 FOOT MAST ARM) | EACH | 1 | |
| 614-81125 | TRAFFIC SIGNAL-LIGHT POLE STEEL (1-25 FOOT MAST ARM) | EACH | 1 | |
| 614-81150 | TRAFFIC SIGNAL LIGHT POLE STEEL (1-50 FOOT MAST ARM) | EACH | 1 | |
| 614-81155 | TRAFFIC SIGNAL LIGHT POLE STEEL (1-55 FOOT MAST ARM) | EACH | 1 | |
| 614-84100 | TRAFFIC SIGNAL PEDESTAL POLE ALUMINUM | EACH | 3 | |
| 614-86105 | TELEMETRY (FIELD) | EACH | 2 | |
| 614 | EMERGENCY VEHICLE TRAFFIC SIGNAL PRIORITY CONTROL SYSTEM | EACH | 2 | |
| 614-87333 | CLOSED CIRCUIT TELEVISION CAMERA (TRAFFIC SURVEILLANCE) | EACH | 2 | |
| 618-01994 | PRESTRESSED CONCRETE BOX (32" THROUGH 48") | SF | 6,075 | |
| 622 | BICYCLE RACK | EACH | 9 | |
| 622 | FREESTANDING PLANTER A | EACH | 25 | |
| 622 | FREESTANDING PLANTER B | EACH | 6 | |
| 622 | CIP CONCRETE BENCH SEAT | LF | 132 | |
| 622 | BENCH TOPPER | EACH | 22 | |
| 622 | STACKED TIMBER BENCH | EACH | 1 | |
| 622 | TIMBER BENCH | EACH | 2 | |
| 623 | HI-POP SPRAY HEAD- 12" | EACH | 116 | |
| 623 | ELECTRIC CONTROL VALVE- CONVENTIONAL | EACH | 2 | |
| 623 | ELECTRIC CONTROL VALVE- TWO WIRE | EACH | 2 | |
| 623-07500 | SOIL MOISTURE SENSOR | EACH | 2 | |
| 623 | RAIN SENSOR | EACH | 1 | |
| 623 | ELECTRIC CONTROLLER- TWO WIRE | EACH | 1 | |
| 623 | RP BACKFLOW PREVENTER- 1" | EACH | 1 | |

| Item | Description | Units | Plan | Final |
|-----------|---|-------|-------|-------|
| 623 | BACKFLOW PREVENTER ENCLOSURE | EACH | 1 | |
| 623 | QUICK COUPLING VALVE | EACH | 3 | |
| 623 | HYDROMETER- 1" | EACH | 1 | |
| 623-02008 | MANUAL DRAIN VALVE | EACH | 3 | |
| 623-05012 | GATE VALVE- 1-1/2" | EACH | 1 | |
| 623 | HDPE MAINLINE- 1-1/2" | LF | 150 | |
| 623 | PVC LATERAL- 1" | LF | 1,000 | |
| 623 | PVC SLEEVING- 2" | LF | 250 | |
| 623 | PVC SLEEVING- 4" | LF | 200 | |
| 623-00165 | DRIP VALVE ASSEMBLY- 1-1/2" | EACH | 1 | |
| 623-00162 | SUBSURFACE DRIPLINE | EACH | 575 | |
| 623 | DRIP LINE BLOW-OUT STUB ASSEMBLY | EACH | 2 | |
| 623 | ARRESTOR WITH GROUNDING PLATE | EACH | 2 | |
| 623 | VALVE DECODER | EACH | 3 | |
| 623 | MAXI TWO WIRE CABLE | LF | 150 | |
| 619-00003 | WATER METER- 3/4" | EACH | 1 | |
| 625-00000 | CONSTRUCTION SURVEYING | LS | 1 | |
| 626-01112 | PUBLIC INFORMATION MANAGEMENT (TIER II) | DAY | 175 | |
| 627-00003 | THERMOPLASTIC PAVEMENT MARKING (INLAID) | SF | 74 | |
| 627-00008 | MODIFIED EPOXY PAVEMENT MARKING | GAL | 21 | |
| 627-30405 | PREFORMED THERMOPLASTIC PAVEMENT MARKING (WORD/ SYMBOL) | SF | 854 | |
| 627-30410 | PREFORMED THERMOPLASTIC PAVEMENT MARKING (XWALK/ STOP LINE) | SF | 1,854 | |
| 629-01210 | ADJUST MONUMENT BOX | EACH | 1 | |
| 630 | TRAFFIC CONTROL | LS | 1 | |
| 630-00000 | FLAGGING | HR | 480 | |
| 630-00003 | UNIFORMED TRAFFIC CONTROL | HR | 16 | |
| 630-00007 | TRAFFIC CONTROL INSPECTION | DAY | 70 | |
| 630-00012 | TRAFFIC CONTROL MANAGEMENT | DAY | 170 | |
| 630-80335 | BARRICADE (TYPE 3 M-A) (TEMPORARY) | EACH | 18 | |
| 630-80336 | BARRICADE (TYPE 3 M-B) (TEMPORARY) | EACH | 13 | |
| 630-80341 | CONSTRUCTION TRAFFIC SIGN (PANEL SIZE A) | EACH | 105 | |
| 630-80342 | CONSTRUCTION TRAFFIC SIGN (PANEL SIZE B) | EACH | 14 | |
| 630-80355 | PORTABLE MESSAGE SIGN PANEL | EACH | 1 | |
| 630-80357 | ADVANCE WARNING FLASHING OR SEQUENCING ARROW PANEL (B FLASH ARROW PANEL (B TY) TYPE) | EACH | 5 | |
| 630-80360 | DRUM CHANNELIZING DEVICE | EACH | 74 | |
| 630-80370 | BARRIER (TEMPORARY) | LF | 250 | |

| Item | Force Account | Units | Plan | Final |
|-----------|--|-------|------|-------|
| 700-70010 | MINOR CONTRACT REVISIONS | F/A | 1 | |
| 700-70072 | OBTAIN POWER FROM XCEL | F/A | 1 | |
| 700-70175 | UNKNOWN UTILITIES | F/A | 1 | |
| 700-70210 | LIGHTING | F/A | 1 | |
| 700-70236 | PERMITS | F/A | 1 | |
| 700-70245 | UTILITY TAP FEE | F/A | 1 | |
| 700-70380 | EROSION CONTROL | F/A | 1 | |
| 700-70305 | AESTHETICS | F/A | 1 | |
| 700-70581 | AIR MONITORING SPECIALIST | F/A | 1 | |
| 700-70588 | RACS EXCAVATION, LOADING, AND TRANSPORTATION | F/A | 1 | |

C:\wip\w_0456241\Connecting_Auraria_SDAQ.dwg

Print Date: 5/18/2022
 File Name: Connecting_Auraria_SDAQ.dwg
 Horiz. Scale: Vert. Scale: As Noted



990 S Broadway, Suite 220
 Denver, CO 80209
 (303) 297-2976 main
 (303) 297-2693 fax
 www.wilsonco.com

| Sheet Revisions | | |
|-----------------|-------------|-------|
| Date: | Comments | Init. |
| 6/28/22 | ADDENDUM #1 | DH |



DEPARTMENT OF TRANSPORTATION & INFRASTRUCTURE
 201 WEST COLFAX AVENUE
 DENVER, CO 80202
 PHONE: (720) 913-4501
 FAX: (720) 913-4544

| As Constructed | CONNECTING AURARIA SUMMARY OF APPROX. QUANTITIES | |
|----------------|--|-----------------------|
| No Revisions: | Designer: KPM | Structure Numbers |
| Revised: | Detailer: KPM | |
| Void: | Sheet Subset: SOAQ | Subset Sheets: 2 of 2 |

Project No./Code

Sheet Number **9**

| TABULATION OF REMOVAL ITEMS | | | | | | | | | | | | | | | | | | | |
|-----------------------------|-----|-------|----------|-----------------|-----------|-----------------------|------------|------------------------------|-------------|-------------------------------|------------|----------------------------|------------|-------------------------------|-------------|-------------------------------|------------|-------------------------|--|
| STATION | | | | 202-00010 | | 202-00090 | | 202-00175 | | 202-00200 | | 202-00203 | | 202-00206 | | 202-00210 | | 202-00220 | |
| | | | | REMOVAL OF TREE | | REMOVAL OF DELINEATOR | | REMOVAL OF CONCRETE DRIVEWAY | | *REMOVAL OF CONCRETE SIDEWALK | | REMOVAL OF CURB AND GUTTER | | REMOVAL OF CONCRETE CURB RAMP | | *REMOVAL OF CONCRETE PAVEMENT | | *REMOVAL OF ASPHALT MAT | |
| BEGIN | END | SIDE | EA | EA | EA | EA | EA | EA | EA | EA | EA | EA | EA | EA | EA | EA | EA | EA | |
| TO | POE | LT/RT | PLAN | FINAL | PLAN | FINAL | PLAN | FINAL | PLAN | FINAL | PLAN | FINAL | PLAN | FINAL | PLAN | FINAL | PLAN | FINAL | |
| | | | 1 | | 11 | | 125 | | 1032 | | 868 | | 115 | | 1789 | | 812 | | |
| PROJECT TOTALS | | | 1 | | 11 | | 125 | | 1032 | | 868 | | 115 | | 1789 | | 812 | | |

*SIDEWALK ASSUMED TO BE 6 INCHES IN DEPTH, CONCRETE PAVEMENT ASSUMED TO BE 12 INCHES IN DEPTH, AND ASPHALT MAT ASSUMED TO BE 13 INCHES IN DEPTH

| TABULATION OF REMOVAL ITEMS | | | | | | | | | | | | | | | | | | | | | |
|-----------------------------|-----|-------|----------|------------------|----------|-----------------------|-----------|------------------------|-----------|------------------------|----------|----------------------|----------|------------------|----------|------------------------|----------|----------------|----------|---------------------|--|
| STATION | | | | 202-01000 | | 202 | | 202 | | 202 | | 202 | | 202 | | 210 | | 210-04010 | | 629-01210 | |
| | | | | REMOVAL OF FENCE | | REMOVAL OF TREE GRATE | | REMOVAL OF BANNER POLE | | REMOVAL OF PLANTER POT | | REMOVAL OF BIKE RACK | | REMOVAL OF BENCH | | RESET TRASH RECEPTICAL | | ADJUST MANHOLE | | ADJUST MONUMENT BOX | |
| BEGIN | END | SIDE | LF | EA | EA | EA | EA | EA | EA | EA | EA | EA | EA | EA | EA | EA | EA | EA | EA | | |
| TO | POE | LT/RT | PLAN | FINAL | PLAN | FINAL | PLAN | FINAL | PLAN | FINAL | PLAN | FINAL | PLAN | FINAL | PLAN | FINAL | PLAN | FINAL | PLAN | FINAL | |
| | | | 7 | | 4 | | 17 | | 20 | | 7 | | 2 | | 2 | | 1 | | 1 | | |
| PROJECT TOTALS | | | 7 | | 4 | | 17 | | 20 | | 7 | | 2 | | 2 | | 1 | | 1 | | |

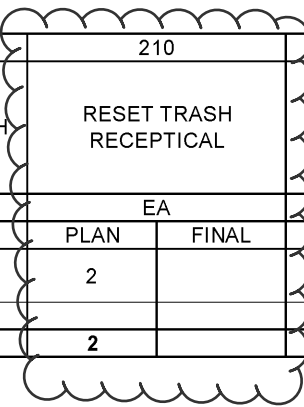

C:\wip\w\0456241\Connecting_Auraria_Renovals.dwg

| | | | | | | | | | | | | | |
|--|---|------------------------|-----------|-------------|---|---|--|---|--|--|--|------------------|----|
| Print Date: 5/18/2022 | <p>990 S Broadway, Suite 220 Denver, CO 80209 (303) 297-2976 main (303) 297-2693 fax www.wilsonco.com</p> | Sheet Revisions | | | <p>DENVER THE MILE HIGH CITY</p> | <p>DEPARTMENT OF TRANSPORTATION & INFRASTRUCTURE 201 WEST COLFAX AVENUE DENVER, CO 80202 PHONE: (720) 913-4501 FAX: (720) 913-4544</p> | <p>As Constructed</p> <p>No Revisions:</p> <p>Revised:</p> <p>Void:</p> | <p>CONNECTING AURARIA REMOVAL TAB</p> <p>Designer: KPM Structure Numbers</p> <p>Detailer: KPM Structure Numbers</p> <p>Sheet Subset: REM TAB Subset Sheets: 1 of 1</p> | | | | Project No./Code | |
| File Name: Connecting_Auraria_Renovals.dwg | | Date: | Comments: | Init.: | | | | | | | | Sheet Number 16 | |
| Horiz. Scale: | | Vert. Scale: As Noted | 6/28/22 | ADDENDUM #1 | | | | | | | | | DH |
| | | | | | | | | | | | | | |

LEGEND

- REMOVAL OF ASPHALT MAT
- REMOVAL OF CONCRETE PAVEMENT
- REMOVAL OF CONCRETE SIDEWALK
- REMOVAL OF CONCRETE CURB RAMP
- REMOVAL OF CURB AND GUTTER
- REMOVAL OF BRIDGE
- REMOVAL OF CONCRETE DRIVEWAY

NOTES

1. SEE SIGNING AND STRIPING PLANS FOR STRIPING REMOVALS
2. SEE SIGNAL PLANS FOR SIGNAL REMOVALS.
3. CONCRETE PAVEMENT REMOVAL SHALL BE FULL PANEL TO THE NEAREST JOINT.
4. REFER TO STORM IMPROVEMENT SHEETS FOR ADDITIONAL REMOVAL ITEMS.
5. REMOVAL OF VOLUNTEER TREES AND MISCELLANEOUS CONCRETE PERFORMED UNDER CLEARING AND GRUBBING.
6. RESET TRASH RECEPTACLES SHALL BE REMOVED PRIOR TO PAVEMENT REMOVAL AND REINSTALLED AFTER NEW PAVEMENT IS ACCEPTED IN PLACE.

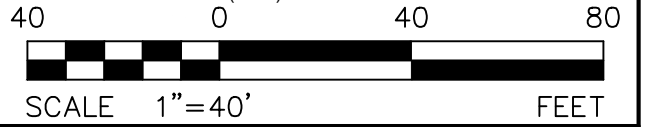
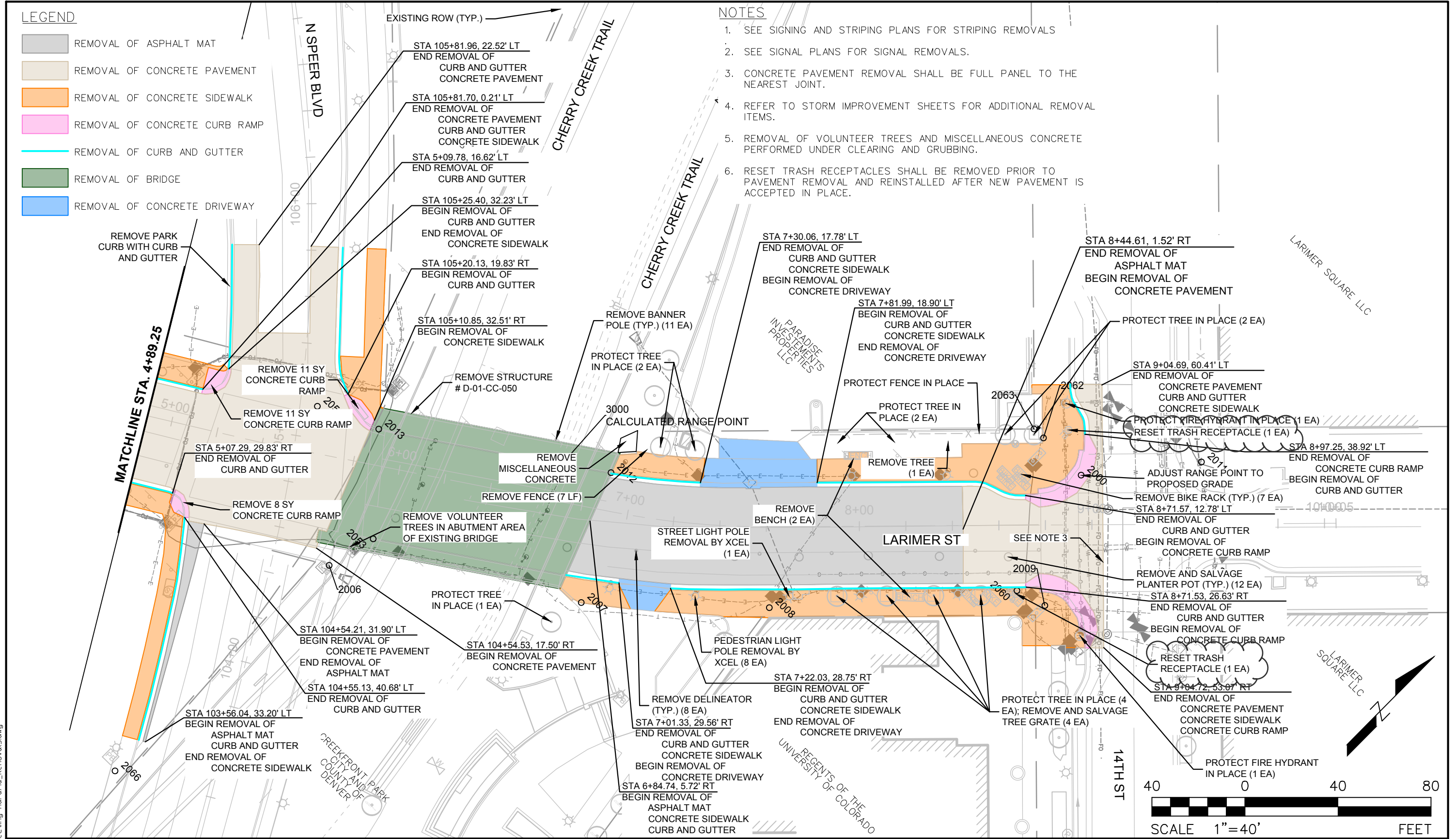

Print Date: 5/18/2022

File Name: Connecting_Auraria_Removals.dwg

Horiz. Scale: 1:40 Vert. Scale: As Noted

WILSON & COMPANY
ENGINEERS & ARCHITECTS

990 S Broadway, Suite 220
Denver, CO 80209
(303) 297-2976 main
(303) 297-2693 fax
www.wilsonca.com

| Sheet Revisions | | |
|-----------------|-------------|-------|
| Date: | Comments | Init. |
| 6/28/22 | ADDENDUM #1 | DH |

DEPARTMENT OF TRANSPORTATION & INFRASTRUCTURE

201 WEST COLFAX AVENUE
DENVER, CO 80202
PHONE: (720) 913-4501
FAX: (720) 913-4544

| |
|-----------------------|
| As Constructed |
| No Revisions: |
| Revised: |
| Void: |

| | | | |
|--|---------|----------------|--------|
| CONNECTING AURARIA REMOVAL PLAN | | | |
| Designer: | KPM | Structure | |
| Detailer: | KPM | Numbers | |
| Sheet Subset: | REMOVAL | Subset Sheets: | 2 of 2 |

| |
|-------------------------|
| Project No./Code |
| Sheet Number 18 |



C:\wip\w0456241\Connecting_Auraria_Removals.dwg

| TABULATION OF MISCELLANEOUS ROADWAY ITEMS | | | | | | | | | | | | | | | |
|---|-----|------|-------|-------------------------------|-------|---|-------|-------------------------------|-------|---|-------|-----------------------|-------|-------------------------------|-------|
| STATION | | | | 412-00600 | | 412 | | 412-00800 | | 412 | | 504 | | 504 | |
| | | | | CONCRETE PAVEMENT (6 INCH) | | CONCRETE PAVEMENT (6 INCH) (COLORED) | | CONCRETE PAVEMENT (8 INCH) | | CONCRETE PAVEMENT (8 INCH) (COLORED) | | CONCRETE PLANTER WALL | | WATER QUALITY PLANTER WALL | |
| BEGIN | END | SIDE | | SY | | SY | | SY | | SY | | LF | | LF | |
| POB | TO | POE | LT/RT | PLAN | FINAL | PLAN | FINAL | PLAN | FINAL | PLAN | FINAL | PLAN | FINAL | PLAN | FINAL |
| | | | | 595 | | 761 | | 973 | | 914 | | 189 | | 170 | |
| PROJECT TOTALS | | | | 595 | | 761 | | 973 | | 914 | | 189 | | 170 | |

| TABULATION OF MISCELLANEOUS ROADWAY ITEMS | | | | | | | | | | | | | | | | | | | |
|---|-----|------|-------|---|-------|--------------------|-------|-------------------------------|-------|---|-------|---------------------------------------|-------|---|-------|--|-------|----------------|--|
| STATION | | | | 608 | | 608-00010 | | 608 | | 608 | | 609-20010 | | 609-21010 | | 609-21020 | | 609-71000 | |
| | | | | DETECTABLE DIRECTIONAL WARNING TILES | | CONCRETE CURB RAMP | | DETECTABLE WARNING SURFACE | | DETECTABLE WARNING SURFACE (CAST IRON) | | CURB AND GUTTER TYPE 2 (SECTION B) | | CURB AND GUTTER TYPE 2 (SECTION I-B) | | CURB AND GUTTER TYPE 2 (SECTION II-B) | | CURB (SPECIAL) | |
| BEGIN | END | SIDE | | LF | | SY | | SF | | SF | | LF | | LF | | LF | | | |
| POB | TO | POE | LT/RT | PLAN | FINAL | PLAN | FINAL | PLAN | FINAL | PLAN | FINAL | PLAN | FINAL | PLAN | FINAL | PLAN | FINAL | | |
| | | | | 609 | | 288 | | 150 | | 227 | | 37 | | 77 | | 316 | | 200 | |
| PROJECT TOTALS | | | | 609 | | 288 | | 150 | | 227 | | 37 | | 77 | | 316 | | 200 | |

| TABULATION OF PAVEMENT ITEMS | | | | | |
|------------------------------|-----|------|-------|---|-------|
| STATION | | | | 403-00721 | |
| | | | | HOT MIX ASPHALT (PATCHING) (ASPHALT) | |
| BEGIN | END | SIDE | | SY | |
| POB | TO | POE | LT/RT | PLAN | FINAL |
| | | | | 18 | |
| PROJECT TOTALS | | | | 18 | |

C:\wip\0456241\Connecting_Auraria_Roadway.dwg

| | | | | | | | | | | | | |
|--|--|------------------------|-------------|-------|--|-----------------------|--------------|--------------------------------|---------|--|------------------|-----------|
| Print Date: 5/18/2022 | <input type="checkbox"/> <input type="checkbox"/> <input type="checkbox"/> <input type="checkbox"/> | Sheet Revisions | | |  DEPARTMENT OF TRANSPORTATION & INFRASTRUCTURE 201 WEST COLFAX AVENUE DENVER, CO 80202 PHONE: (720) 913-4501 FAX: (720) 913-4544 | As Constructed | | CONNECTING AURARIA ROADWAY TAB | | | Project No./Code | |
| File Name: Connecting_Auraria_Roadway.dwg | | Date: | Comments | Init. | | No Revisions: | Designer: | | | | KPM | Structure |
| Horiz. Scale: Vert. Scale: As Noted | | 6/28/22 | ADDENDUM #1 | DH | | Revised: | Detailer: | KPM | Numbers | | | |
|  990 S Broadway, Suite 220 Denver, CO 80209 (303) 297-2976 main (303) 297-2693 fax www.wilsonco.com | | | | Void: | Sheet Subset: RDWY TAB | Subset Sheets: 1 of 1 | Sheet Number | 20 | | | | |

LEGEND

- 8" CONCRETE PAVEMENT
(SEE NOTE 5)
- CONCRETE CURB RAMP
- 6" CONCRETE PAVEMENT
(SEE NOTE 5)
- CURB AND GUTTER
- HMA (PATCHING)(ASPHALT)
- BRIDGE
(SEE BRIDGE PLANS FOR SURFACING)
- DETECTABLE WARNING SURFACE

NOTES

1. SEE INTERSECTION DETAILS FOR MORE INFORMATION ON GRADING AND CURB RAMPS.
2. SEE SIGNING AND STRIPING PLANS FOR MORE INFORMATION ON STRIPING LAYOUTS.
3. SEE SIGNAL PLANS FOR MORE DETAILS ON THE PROPOSED SIGNALS.
4. SEE STORM IMPROVEMENT PLANS FOR MORE INFORMATION ON PROPOSED STORM NETWORK.
5. SEE JOINTING AND LANDSCAPE PLANS FOR COLORED CONCRETE EXTENTS.
6. TRANSITION PROPOSED CURB AND GUTTER TO MATCH EXISTING OVER IT'S LAST 10'.

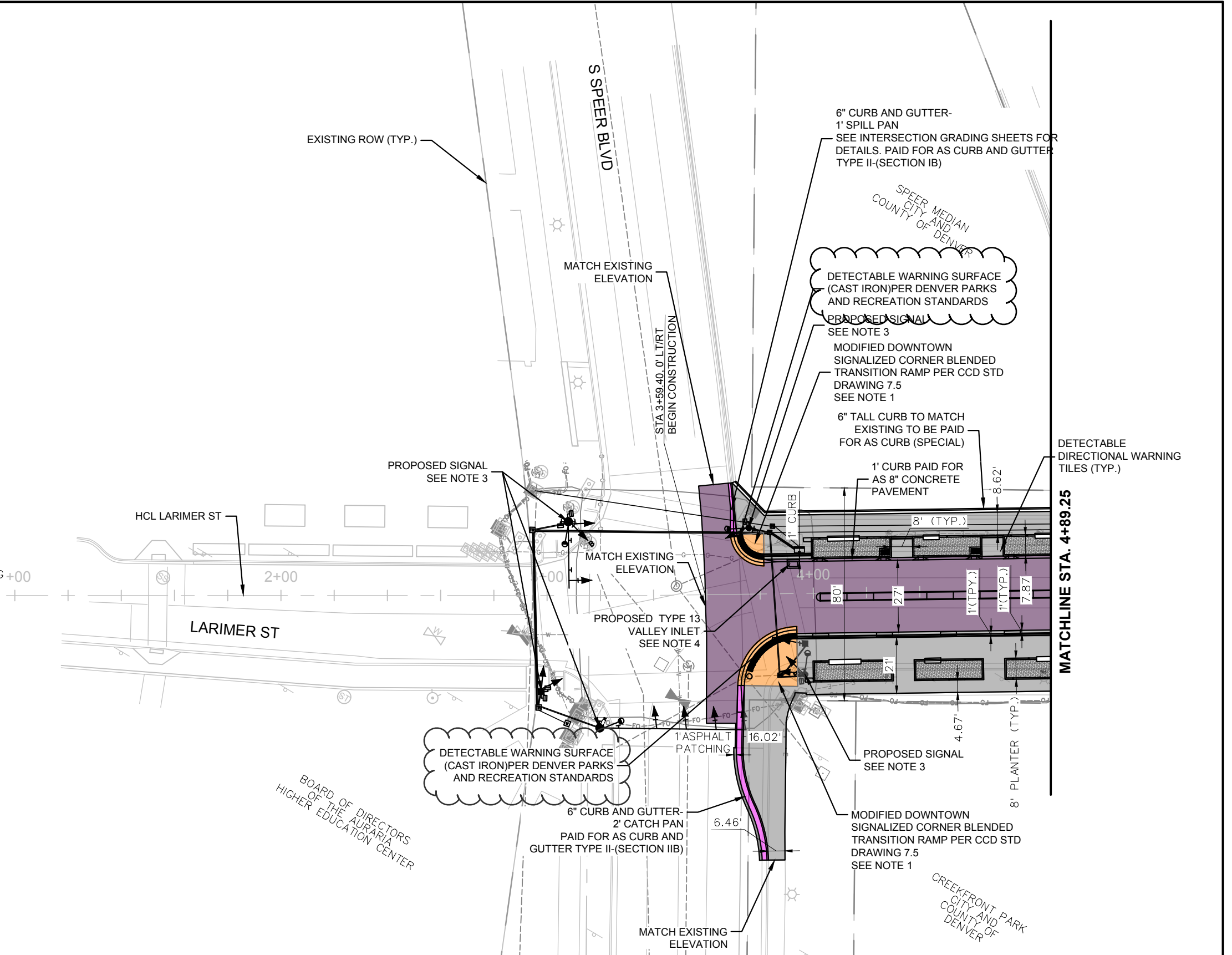

C:\wip\w_0456241\Connecting_Auraria_Roadway.dwg

| | |
|---|-----------------------|
| Print Date: 5/18/2022 | |
| File Name: Connecting_Auraria_Roadway.dwg | |
| Horiz. Scale: 1:40 | Vert. Scale: As Noted |
| | |
| <small>990 S Broadway, Suite 220 Denver, CO 80209 (303) 297-2976 main (303) 297-2693 fax www.wilsonca.com</small> | |

| Sheet Revisions | | |
|-----------------|-------------|-------|
| Date: | Comments | Init. |
| 6/28/22 | ADDENDUM #1 | DH |
| | | |
| | | |

DEPARTMENT OF TRANSPORTATION & INFRASTRUCTURE

201 WEST COLFAX AVENUE
DENVER, CO 80202
PHONE: (720) 913-4501
FAX: (720) 913-4544

| |
|-----------------------|
| As Constructed |
| No Revisions: |
| Revised: |
| Void: |

| CONNECTING AURARIA ROADWAY PLAN | | | |
|---------------------------------|------|----------------|--------|
| Designer: | KPM | Structure | |
| Detailer: | KPM | Numbers | |
| Sheet Subset: | RDWY | Subset Sheets: | 1 of 2 |

| |
|-------------------------|
| Project No./Code |
| |
| Sheet Number 21 |

NOTES

1. SEE INTERSECTION DETAILS FOR MORE INFORMATION ON GRADING AND CURB RAMP.
2. SEE SIGNING AND STRIPING PLANS FOR MORE INFORMATION ON STRIPING LAYOUTS.
3. SEE SIGNAL PLANS FOR MORE DETAILS ON THE PROPOSED SIGNALS.
4. SEE STORM IMPROVEMENT PLANS FOR MORE INFORMATION ON PROPOSED STORM NETWORK.
5. SEE JOINTING AND LANDSCAPE PLANS FOR COLORED CONCRETE EXTENTS.
6. TRANSITION PROPOSED CURB AND GUTTER TO MATCH EXISTING OVER IT'S LAST 10'.

LEGEND

- 8" CONCRETE PAVEMENT (SEE NOTE 5)
- CONCRETE CURB RAMP
- 6" CONCRETE PAVEMENT (SEE NOTE 5)
- CURB AND GUTTER
- HMA (PATCHING)(ASPHALT)
- BRIDGE (SEE BRIDGE PLANS FOR SURFACING)
- DETECTABLE WARNING SURFACE

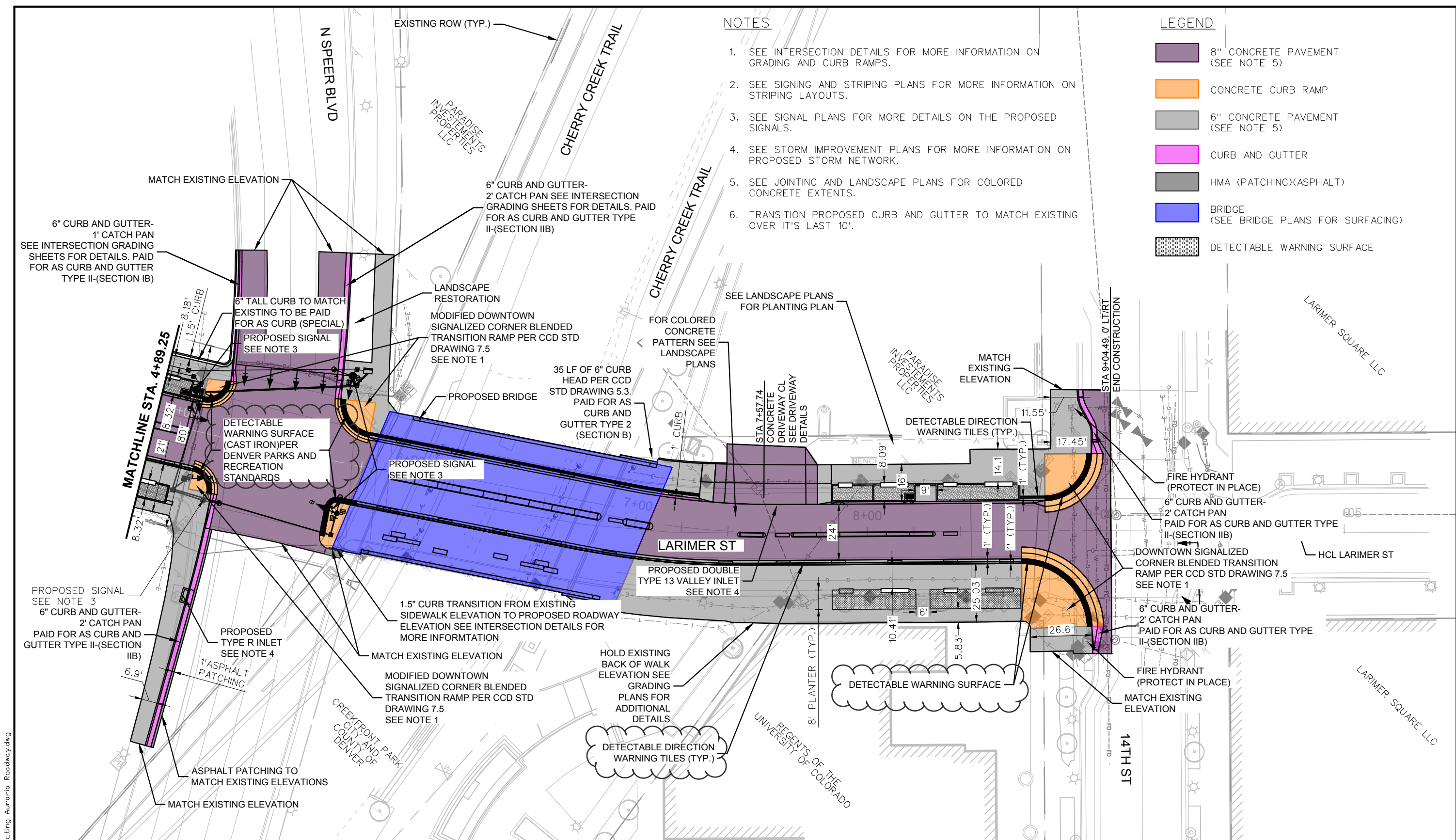

| Print Date: 5/18/2022 File Name: Connecting Auraria_Roadway.dwg Horiz. Scale: 1:40 Vert. Scale: As Noted | Sheet Revisions | DEPARTMENT OF TRANSPORTATION & INFRASTRUCTURE 201 WEST COLFAX AVENUE DENVER, CO 80202 PHONE: (720) 913-4501 FAX: (720) 913-4544 | As Constructed No Revisions: Revised: Void: | CONNECTING AURARIA ROADWAY PLAN Designer: KPM Detailer: KPM Sheet Subset: RDWY Subset Sheets: 2 of 2 | Project No./Code Sheet Number 22 | | | | | | |
|---|--|--|---|---|---|-------------|----|---|--|--|--|
| 0000 | <table border="1" style="width: 100%; border-collapse: collapse;"> <thead> <tr> <th>Date:</th> <th>Comments:</th> <th>Init.</th> </tr> </thead> <tbody> <tr> <td>6/28/22</td> <td>ADDENDUM #1</td> <td>DH</td> </tr> </tbody> </table> | Date: | Comments: | Init. | 6/28/22 | ADDENDUM #1 | DH | <p>DENVER THE MILE HIGH CITY</p> | | | |
| Date: | Comments: | Init. | | | | | | | | | |
| 6/28/22 | ADDENDUM #1 | DH | | | | | | | | | |

GENERAL NOTES

Except as shown in the plans, structure excavation and backfill shall be in Accordance with M-206-2.

Expansion joint material shall meet AASHTO Specification M213.

The final finish for the concrete surfaces of the bridge rails and curbs shall be Class 2. All other exposed concrete surfaces shall receive a Class 1 final finish to one foot below the ground line.

The following structural steel shall be AASHTO M270 Grade 50 (ASTM A-572): H-Piles.

All rail tubes shall be ASTM A-1085. All posts, base plates, and splice tubes fabricated by welding shall be ASTM A-572 Grade 50.

Leveling pads are unlaminated bearings. They shall be cut or molded from AASHTO elastomer grade 3, 4, or 5 as described in CDOT Standard Specifications for Road and Bridge Construction tables 705-1 and 705-2 with a durometer (shore "A") hardness of 60.

All the provisions for bridge deck concrete shall also apply to approach slab concrete.

An emergency deck construction joint may be located at the one quarter span point back from an abutment with respect to the direction of the deck placement.

Grade 60 reinforcing steel is required.

All reinforcing steel shall be epoxy coated unless otherwise noted.

Ⓝ denotes non coated reinforcing steel.

Structural concrete exposed to soil shall conform to cementitious materials requirements Class 0.

The Contractor shall be responsible for the stability of the structure during construction.

Stations, Elevations, and Dimensions contained in these plans are calculated from a recent field survey. The Contractor shall verify all dependent dimensions in the field before ordering or fabricating any material.

All longitudinal and transverse dimensions are measured horizontally and include no correction for grade.

The information shown on these plans concerning the type and location of underground utilities is not guaranteed to be accurate or all inclusive. The Contractor is responsible for making his own determination as to the type and location of underground utilities as may be necessary to avoid damage thereto. The Contractor shall contact the Utility Notification Center of Colorado at 811 (1-800-922-1987) at least 3 days (2 days not including the day of notification) prior to any excavation or other earthwork.

The Contractor shall take care to avoid damage to the existing retaining walls that are to remain in place. See the Nationwide Permit Verification, NWO-2022-00282-DEN for additional requirements.

For Structure Number installation details, see Sheet B25.

Bird Spikes shall be installed along the top of the existing retaining walls underneath the bridge when the gap between the girders and top of wall is greater than 4".

DESIGN DATA

AASHTO, Ninth Edition LRFD with current interims

Design Method: Load and Resistance Factor Design

Live Load: HL-93 (design truck or tandem, and design lane load) and CO Permit Vehicle

Dead Load: Assumes 36.67 lbs. per sq. ft. for bridge deck overlay
Assumes 5 psf allowance for future utilities
Load Case 1: 3 Traffic Lanes and no landscaping
Load Case 2: 1 Traffic Lane and landscaping

Proposed and Future Landscaping load shall not exceed the lane load of 63 pcf

Reinforced Concrete: Class D Concrete: f'c = 4,500 psi
Reinforcing Steel: fy = 60,000 psi
Polyester Concrete Overlay: See Special Provisions

Structural Steel: ASTM A-572 Grade 50 fy = 50,000 psi
And as noted in the plans

Precast prestressed concrete: Class PS concrete f'c = (see details)
f's = 270,000 psi

SEISMIC DESIGN CRITERIA

Earthquake Design method: FORCE BASED Design
Latitude = 39.747°
Longitude = -105.0001°

AASHTO Spectrum for 7% PE in 75 years (1000yr Return Period)
Period Sa (sec) (g)
0.0 0.117 PGA - Site Class B
0.2 0.213 Ss - Site Class B
1.0 0.058 S1 - Site Class B

Spectral Response Accelerations:
As = Fpga*PGA, SDs = Fa*Ss, and SD1 = Fv*S1
Fpga = 1.565, Fa = 1.6, Fv = 2.4
Period Sa (sec) (g)
0.0 0.183 As - Site Class D
0.2 0.341 SDs - Site Class D
1.0 0.139 SD1 - Site Class D

Operational Class: Other

Seismic Zone: Zone 1

ABBREVIATIONS

| | |
|-----------------------------|-----------------------------|
| AS=AS SHOWN | HMA=HOT MIX ASPHALT |
| BF=BACK FACE | MAX=MAXIMUM |
| BRG=BEARING | MIN=MINIMUM |
| CLR=CLEAR | NF=NEAR FACE |
| CONC=CONCRETE | ROW=RIGHT OF WAY |
| CONT=CONTINUOUS | SPA=SPACING |
| DIA=DIAMETER | STA=STATION |
| EF=EACH FACE | TYP=TYPICAL |
| ELEV=ELEVATION | UON=UNLESS OTHERWISE NOTED |
| ES=EACH SIDE | WP=WORKING POINT |
| EQ SPA=EQUAL SPACING | WSE=WATER SURFACE ELEVATION |
| EXIST=EXISTING | |
| FF=FRONT FACE | |
| HCL=HORIZONTAL CONTROL LINE | |

INDEX OF DRAWINGS

- B1 GENERAL INFORMATION
- B2 SUMMARY OF QUANTITIES
- B3 GENERAL LAYOUT
- B4 TYPICAL SECTION
- B5 ENGINEERING GEOLOGY (1 OF 6)
- B6 ENGINEERING GEOLOGY (2 OF 6)
- B7 ENGINEERING GEOLOGY (3 OF 6)
- B8 ENGINEERING GEOLOGY (4 OF 6)
- B9 ENGINEERING GEOLOGY (5 OF 6)
- B10 ENGINEERING GEOLOGY (6 OF 6)
- B11 BRIDGE HYDRAULIC INFORMATION
- B12 CONSTRUCTION LAYOUT
- B13 PILING LAYOUT
- B14 ABUTMENT 1 PLAN AND ELEVATION
- B15 ABUTMENT 2 PLAN AND ELEVATION
- B16 ABUTMENT DETAILS
- B17 WINGWALL DETAILS
- B18 SUPERSTRUCTURE DETAILS
- B19 DECK REINFORCING PLAN
- B20 GIRDER DETAILS
- B21 BRIDGE RAIL TYPE 10MASH
- B22 PLINTH DETAILS
- B23 APPROACH SLAB 1
- B24 APPROACH SLAB 2
- B25 STRUCTURE IDENTIFICATION PANEL DETAIL
- B26 MECHANICALLY STABILIZED BACKFILL
- B27 EXCAVATION AND BACKFILL
- B28 BRIDGE DECK ELEVATIONS (1 OF 3)
- B29 BRIDGE DECK ELEVATIONS (2 OF 3)
- B30 BRIDGE DECK ELEVATIONS (3 OF 3)

BRIDGE DESCRIPTION

Single Span (103'-9³/₄") Bridge, Concrete Slab and Prestressed Concrete Box Girder, side by side, over Cherry Creek
62'-0" Out to Out Width, 59'-0" Curb to Curb
Type 10MASH Bridge Rail
11° 33'57" Skew
1'-6" Curb, 12'-0" Walk (Left), 20'-0" Walk (Right)

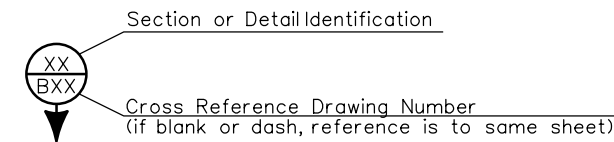

**Know what's below.
Call before you dig.**

cefisher 10:56:02 AM pww\wils-pw.bentley.com\wils-pw\Documents\8100-TRN\City & County of Denver, CO\20-100-077-00_CCD 202055806 Connecting Auraria\00000\Bridges\Drawings\B01_BRDG_Gen-Info

| | | | | | | |
|------------------------------|-----------------------|------------------------|--|----------------------------|------------------------|--------------------------|
| Print Date: 6/27/2022 | | Sheet Revisions | As Constructed | GENERAL INFORMATION | | Project No./Code |
| File Name: B01_BRDG_Gen-Info | | Date: 6-27-22 | No Revisions: | Designer: M. Hildahl | | DOTI-202055806-00 |
| Horiz. Scale: 1:5 | Vert. Scale: As Noted | Comments: Addendum #1 | Revised: | Structure Numbers | D-01-CC-050A | |
| Unit Information | Unit Leader Initials | | Void: | Detailer: C. Fisher | Sheet Subset: BRIDGE | Subset Sheets: B1 of B30 |
| | | | DEPARTMENT OF TRANSPORTATION & INFRASTRUCTURE 201 WEST COLFAX AVENUE DENVER, CO 80202 PHONE: (720) 913-4501 FAX: (720) 913-4544 | | Sheet Number 53 | |

SUMMARY OF QUANTITIES

| Item No. | Description | Unit | Superstructure | Abutment 1 | Abutment 2 | Approach Slab | Total Quantity | As Constructed |
|-----------|--|------|----------------|------------|------------|---------------|----------------|----------------|
| 202-00001 | Removal of Structure | EA | | | | | 1 | |
| 206-00000 | Structure Excavation | CY | | 209 | 276 | | 485 | |
| 206-00100 | Structure Backfill (Class 1) | CY | | 150 | 159 | | 309 | |
| 206-00200 | Structure Backfill (Class 2) | CY | | 10 | 60 | | 70 | |
| 206-00360 | Mechanical Reinforcement of Soil | CY | | 150 | 159 | | 309 | |
| 206-01781 | Shoring (Area 1) | LS | | | 1 | | 1 | |
| 502-00100 | Drilling Hole to Facilitate Pile Driving | LF | | 112 | 112 | | 224 | |
| 502-11274 | Steel Piling (HP 12x74) | LF | | 251 | 194 | | 445 | |
| 506-00212 | Riprap (12 Inch) | CY | | 14 | | | 14 | |
| 509-00000 | Structural Steel | LB | 42 | | | | 42 | |
| 514-99999 | Fence (Special)(6-18 Inch) | LF | | | 81 | | 81 | |
| 515-00400 | Concrete Sealer | SY | 429 | | | 137 | 566 | |
| 519-03035 | Place Thin Bonded Overlay (Polyester Concrete) | SY | 307 | | | 56 | 363 | |
| 519-03055 | Furnish Thin Bonded Overlay (Polyester Concrete) | CF | 173 | | | 32 | 205 | |
| 601-04550 | Concrete Class D | CY | 183 | 44 | 56 | 83 | 366 | |
| 601-40300 | Structural Concrete Coating | SY | 188 | 24 | 54 | 47 | 313 | |
| 601-40302 | Structural Concrete Coating (Anti-Graffiti) | SF | | 215 | 484 | | 699 | |
| 602-00020 | Reinforcing Steel (Epoxy Coated) | LB | 19498 | 5210 | 8123 | 11513 | 44343 | |
| 606-11035 | Bridge Rail Type 10 MASH | LF | 179 | | | 34 | 213 | |
| 613-00100 | 1 Inch Electrical Conduit | LF | 104 | | | 40 | 144 | |
| 613-00200 | 2 Inch Electrical Conduit | LF | 312 | | | 120 | 432 | |
| 618-01994 | Prestressed Concrete Box (32" Through 48") | SF | 6075 | | | | 6075 | |

AM: 11:13:38 AM pw: \\wils-pw.bentley.com\wils-pw\Documents\8100-TRN\City & County of Denver, CO\20-100-077-00_CCD 202055806 Connecting Auraria 00000\Drawings\B02_BRDG_SumOfQuant

Print Date: 6/27/2022

File Name: B02_BRDG_SumOfQuant

Horiz. Scale: 1:1 Vert. Scale: As Noted

Unit Information Unit Leader Initials



990 South Broadway, Suite 220
 Denver, CO 80209
 (303) 297-2976 main
 (303) 297-2693 fax
 www.wilsonco.com

| Sheet Revisions | | |
|-----------------|-------------|-------|
| Date: | Comments | Init. |
| 6-27-22 | Addendum #1 | MCH |
| | | |
| | | |



DEPARTMENT OF TRANSPORTATION & INFRASTRUCTURE
 201 WEST COLFAX AVENUE
 DENVER, CO 80202
 PHONE: (720) 913-4501
 FAX: (720) 913-4544

| As Constructed |
|----------------|
| No Revisions: |
| Revised: |
| Void: |

SUMMARY OF QUANTITIES

Designer: M. Hildahl Structure Numbers: D-01-CC-050A
 Detailer: C. Fisher

Sheet Subset: BRIDGE Subset Sheets: B2 of B30

Project No./Code
 DOTI-202055806-00

Sheet Number **54**

cefisher 12:08:54 PM p:\wils-pw\Documents\100-TRN-City & County of Denver, CO\20-100-077-00_CCD 202055806 Connecting Auraria\00000\Drawings\B03_BRDG_General-Layout

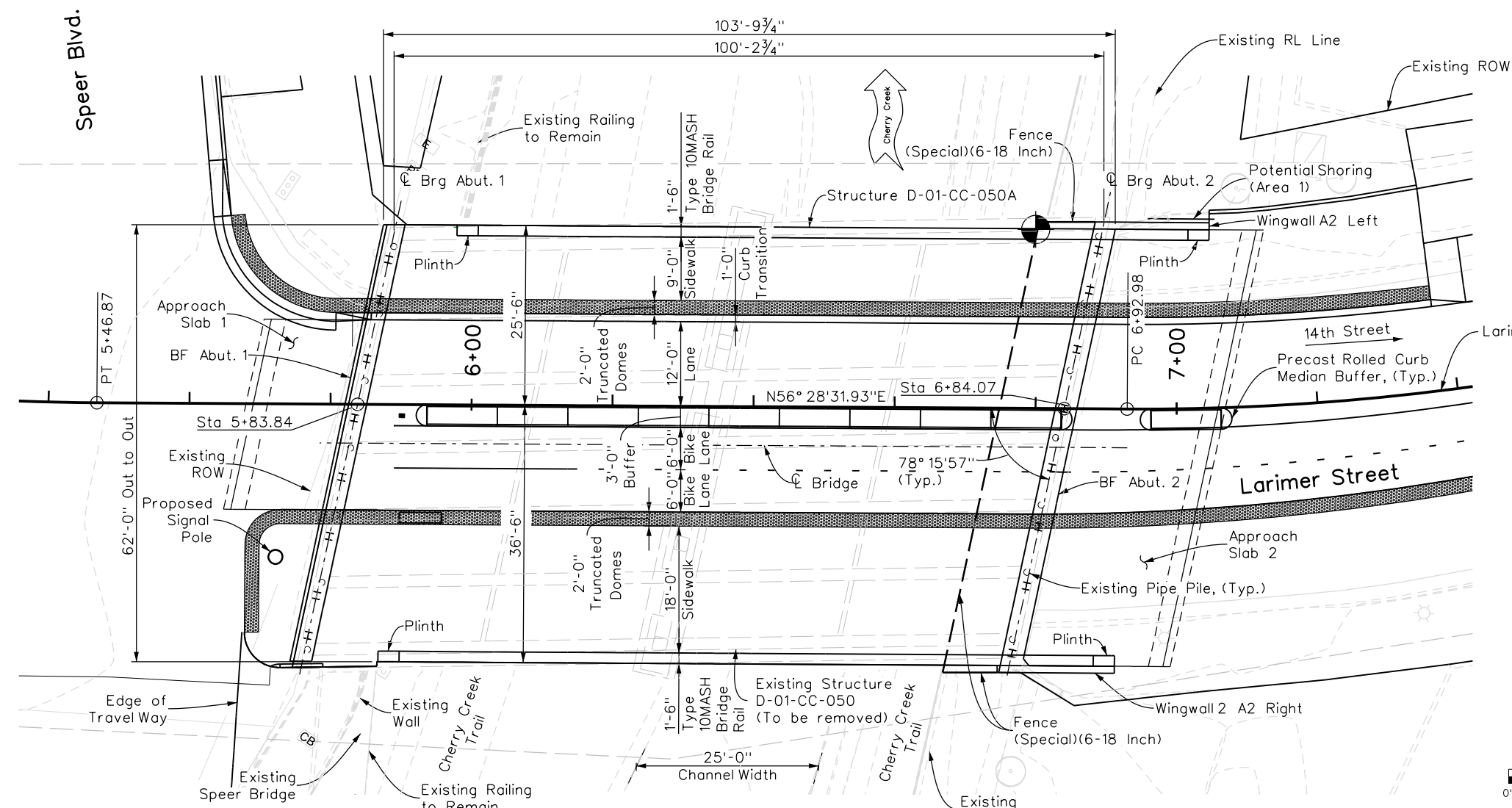

PLAN

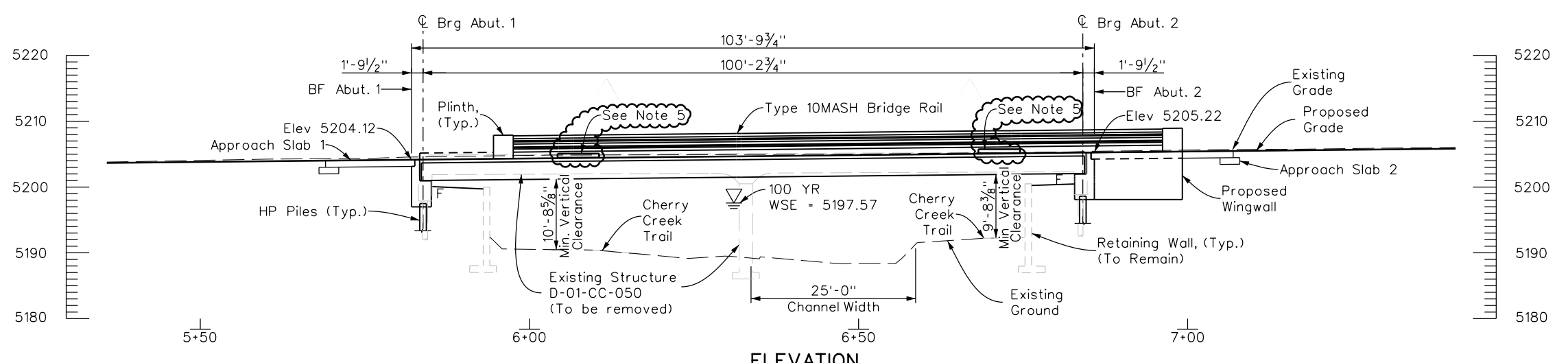

ELEVATION

Indicates location of minimum vertical clearance

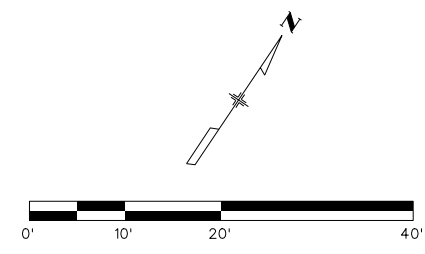

NOTES

- See Utility Plans for utility descriptions & dispositions.
- See Sheet B28-B30 for top of roadway/concrete elevations.
- Pier columns shall be removed to 2'-0" below grade or top of existing footing, whichever comes first.
- Elevations shown are at finished grade at HCL.
- Remove four (4) "Larimer St" signs from existing bridge and reset on new Type 10 Mash Concrete Base, centered over the trail on each side of the bridge. Work shall be incidental to the bridge removal item.

| | |
|--|-----------------------|
| Print Date: 6/27/2022 | |
| File Name: B03_BRDG_General-Layout | |
| Horiz. Scale: 1:20 | Vert. Scale: As Noted |
| Unit Information | Unit Leader Initials |
| 990 South Broadway, Suite 220 Denver, CO 80209 (303) 297-2976 main (303) 297-2693 fax www.wilsonco.com | |

| Sheet Revisions | | |
|-----------------|-------------|-------|
| Date: | Comments | Init. |
| 6-27-22 | Addendum #1 | MCH |

DEPARTMENT OF TRANSPORTATION & INFRASTRUCTURE

201 WEST COLFAX AVENUE
 DENVER, CO 80202
 PHONE: (720) 913-4501
 FAX: (720) 913-4544

| |
|-----------------------|
| As Constructed |
| No Revisions: |
| Revised: |
| Void: |

| GENERAL LAYOUT | | | |
|----------------|------------|-------------------|--------------|
| Designer: | M. Hildahl | Structure Numbers | D-01-CC-050A |
| Detailer: | C. Fisher | Subset Sheets: | B3 of B30 |
| Sheet Subset: | BRIDGE | | |

| | |
|-------------------------|-------------------|
| Project No./Code | DOTI-202055806-00 |
| Sheet Number | 55 |

ABUTMENT 1 SEAT ELEVATIONS

| | | | | | | | | | |
|---------|---------|---------|---------|---------|---------|---------|---------|---------|---------|
| A | B | C | D | E | F | G | H | I | J |
| 5200.16 | 5200.19 | 5200.29 | 5200.32 | 5200.35 | 5200.38 | 5200.41 | 5200.48 | 5200.56 | 5200.63 |

ABUTMENT 2 SEAT ELEVATIONS

| | | | | | | | | | |
|---------|---------|---------|---------|---------|---------|---------|---------|---------|---------|
| A | B | C | D | E | F | G | H | I | J |
| 5200.95 | 5201.06 | 5201.23 | 5201.34 | 5201.45 | 5201.56 | 5201.66 | 5201.74 | 5201.81 | 5201.89 |

NOTES:

- Structural Concrete Coating shall be applied to all exposed concrete surfaces of the abutments to 1 foot below finished ground line. Structural Concrete Coating (Anti-Graffiti) shall be applied to all exposed concrete surfaces of the abutments and wingwalls to 1 foot below finished grade line.
- Grout for #8 dowels shall be approved nonshrink or epoxy (4500 psi) from CDOT's Approved Products List. Grout shall not be paid separately but shall be included in 601 Concrete (Class D).

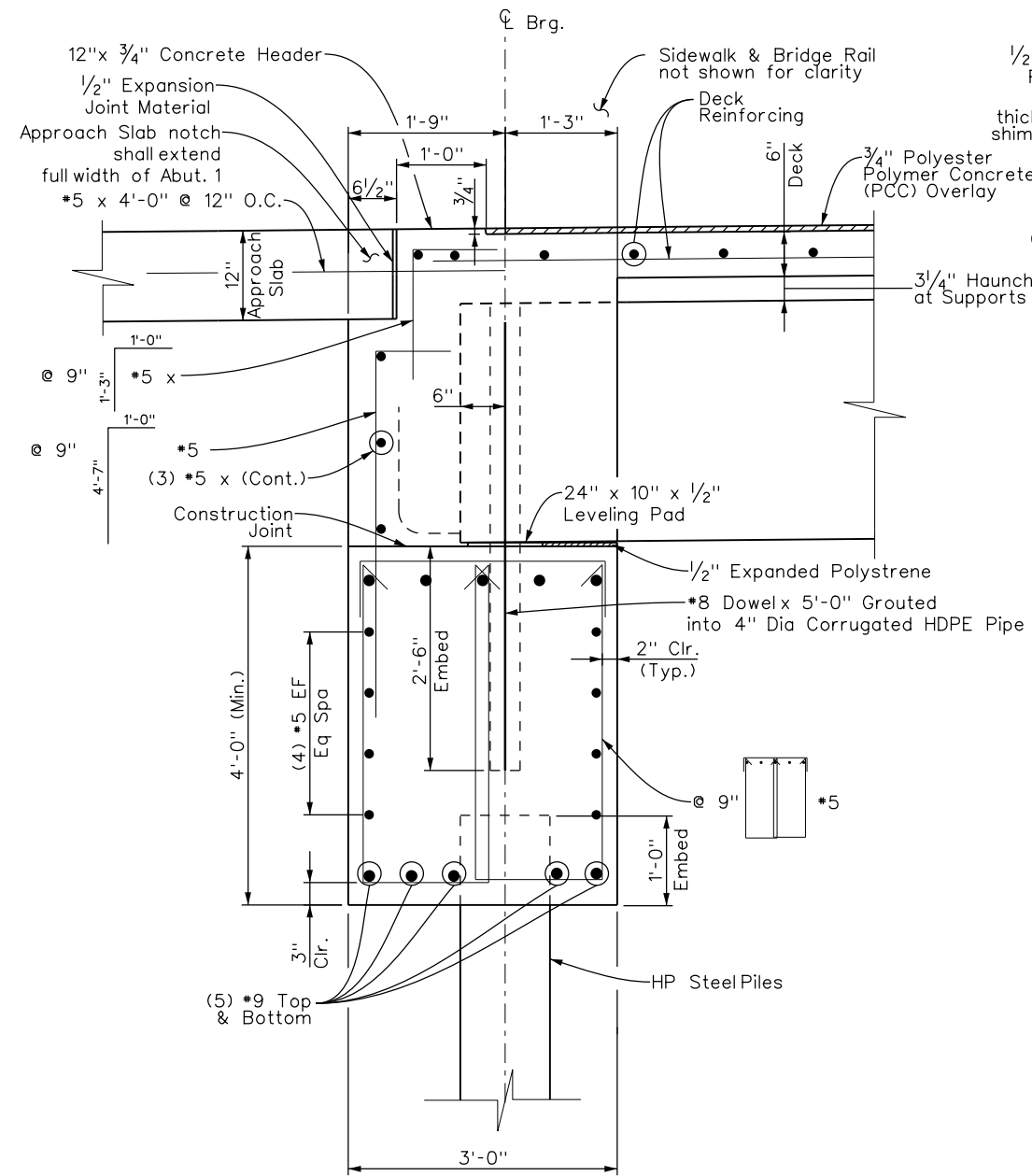

SECTION A/B14

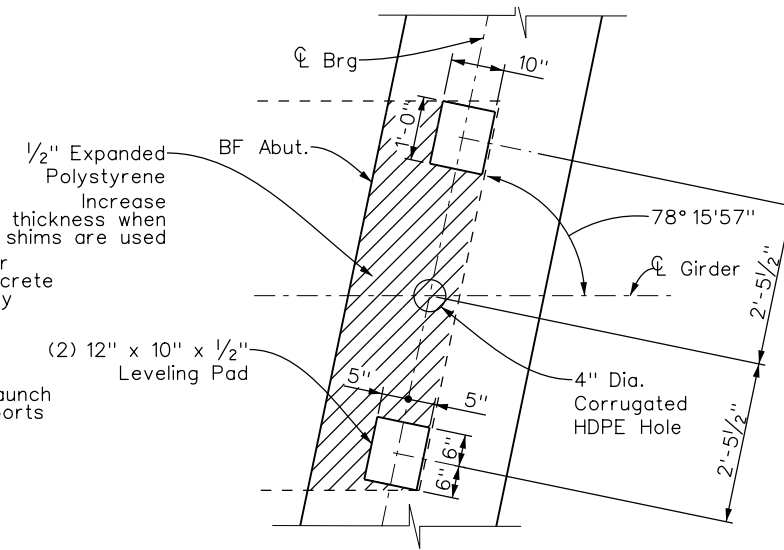

ABUT #2 LEVELING PAD DETAIL

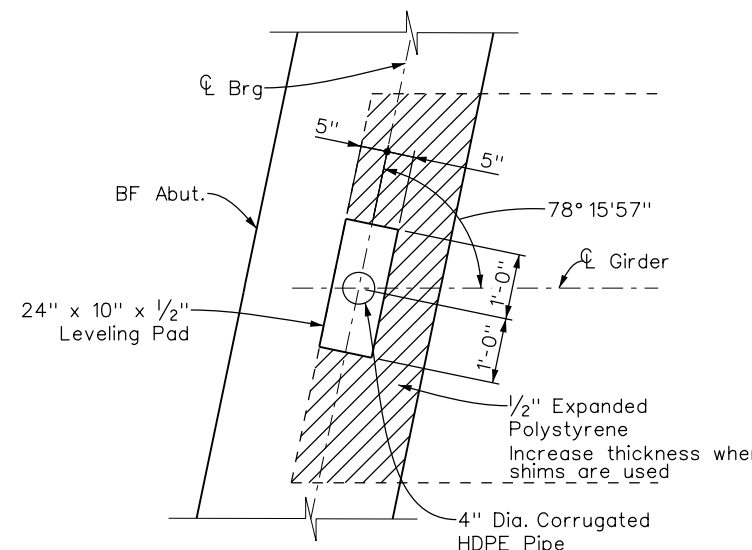

ABUT #1 LEVELING PAD DETAIL

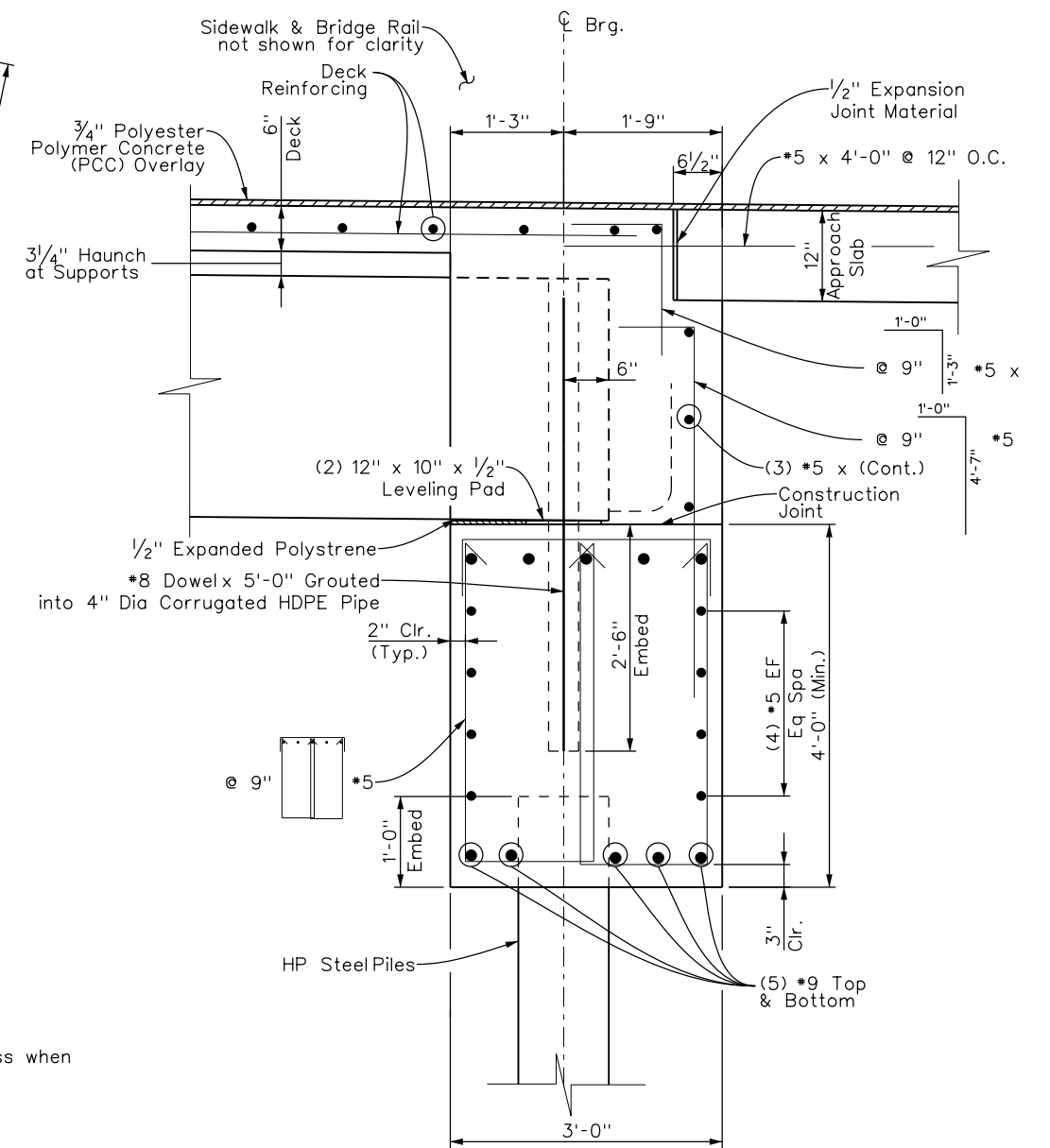

SECTION B/B15

cefisher 12:19:47 PM p:\wils-pw\bentley.com\wils-pw\Documents\8100-TRN\City & County of Denver, CO\20-100-077-00_CCD 202055806 Connecting Auraria\00000\BRDG_Abutment-Details03

| | |
|--|--|
| Print Date: 6/27/2022 | |
| File Name: B16_BRDG_Abutment-Details03 | |
| Horiz. Scale: 1:2 Vert. Scale: As Noted | |
| Unit Information Unit Leader Initials | |

| Sheet Revisions | | |
|-----------------|-------------|-------|
| Date: | Comments | Init. |
| 6-27-22 | Addendum #1 | MCH |
| | | |
| | | |

DEPARTMENT OF TRANSPORTATION & INFRASTRUCTURE
 201 WEST COLFAX AVENUE
 DENVER, CO 80202
 PHONE: (720) 913-4501
 FAX: (720) 913-4544

| |
|-----------------------|
| As Constructed |
| No Revisions: |
| Revised: |
| Void: |

| ABUTMENT DETAILS | | | |
|------------------|------------|-------------------|--------------|
| Designer: | M. Hildahl | Structure Numbers | D-01-CC-050A |
| Detailer: | C. Fisher | Subset Sheets: | B16 of B30 |
| Sheet Subset: | BRIDGE | | |

| |
|-------------------------|
| Project No./Code |
| DOTI-202055806-00 |
| Sheet Number |
| 68 |

cefisher 12:29:24 PM pw:\wils-pw\Documents\8100-TRN\City & County of Denver, CO\20-100-077-00_CCD 202055806 Connecting Auraria\0000\Bridges\Drawings\B23_BRDG_Approach-Slab01

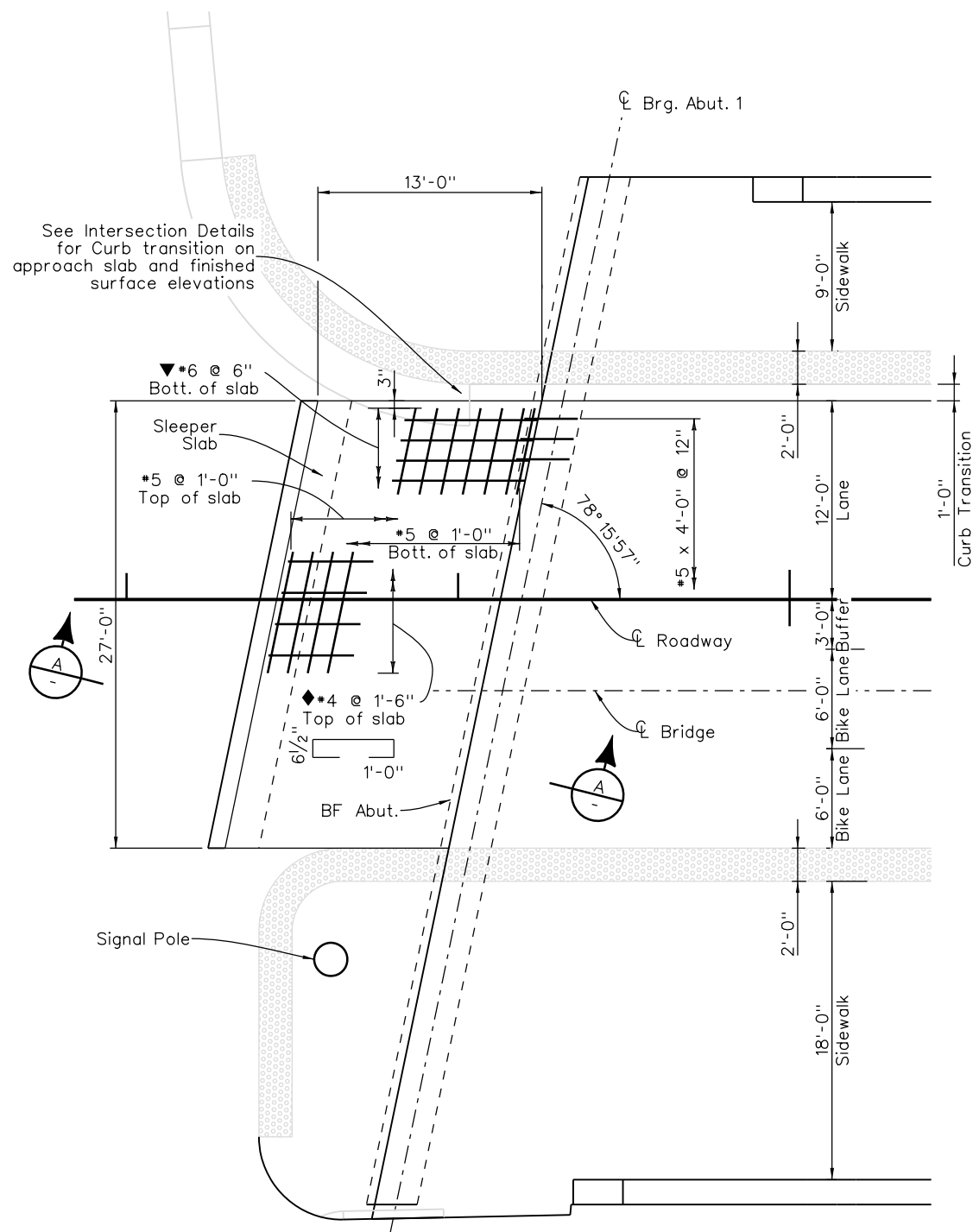

PLAN

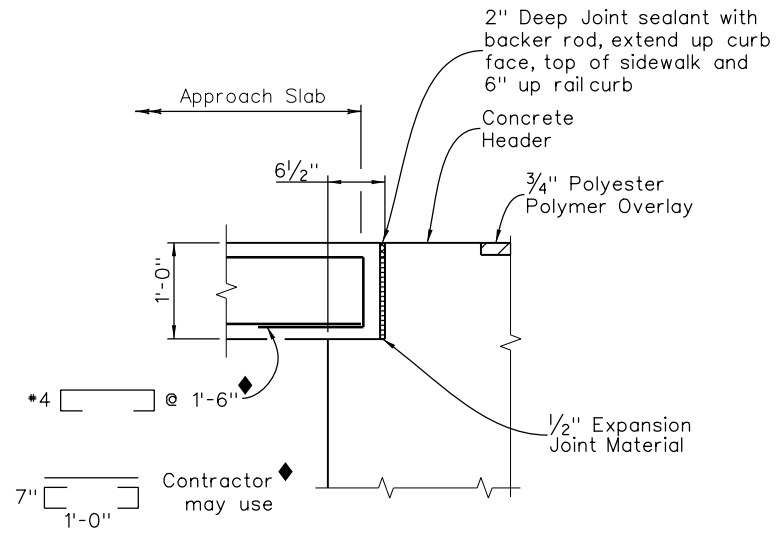

DETAIL 1

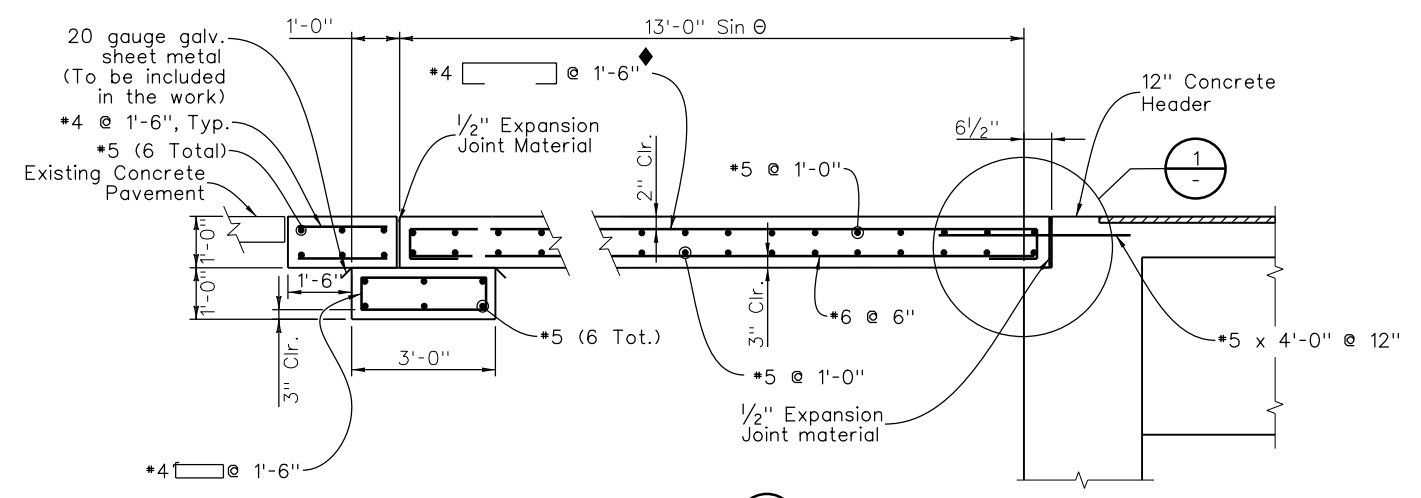

SECTION A-A

NOTES:
 Concrete Class D (Bridge) shall be used for approach slabs.
 Approach slab concrete shall be cured in accordance with the Specifications for Bridge Deck Concrete in Subsection 601.
 1/2" expansion joint material shall meet AASHTO Spec. M213.
 Saw cut 3/4" deep of new Polyester Polymer Concrete (PPC) Overlay for 1/2" joint sealant with backer rod. The joint sealant with backer rod shall be included in Item 519, Place Thin Bonded Overlay (Polyester Concrete).

| | |
|--|-----------------------|
| Print Date: 6/27/2022 | |
| File Name: B23_BRDG_Approach-Slab01 | |
| Horiz. Scale: 1:1 | Vert. Scale: As Noted |
| Unit Information | Unit Leader Initials |
| 990 South Broadway, Suite 220 Denver, CO 80209 (303) 297-2976 main (303) 297-2693 fax www.wilsonco.com | |

| Sheet Revisions | | |
|-----------------|-------------|-------|
| Date: | Comments | Init. |
| 6-27-22 | Addendum #1 | MCH |
| | | |
| | | |

DEPARTMENT OF TRANSPORTATION & INFRASTRUCTURE
 201 WEST COLFAX AVENUE
 DENVER, CO 80202
 PHONE: (720) 913-4501
 FAX: (720) 913-4544

| |
|-----------------------|
| As Constructed |
| No Revisions: |
| Revised: |
| Void: |

| | | | |
|------------------------|------------|-------------------|--------------|
| APPROACH SLAB 1 | | | |
| Designer: | M. Hildahl | Structure Numbers | D-01-CC-050A |
| Detailer: | C. Fisher | Subset Sheets: | B23 of B30 |
| Sheet Subset: | BRIDGE | | |

| |
|-------------------------|
| Project No./Code |
| DOTI-202055806-00 |
| Sheet Number |
| 75 |

cefisher 12:39:12 PM p:\wils-pw\Bentley.com\wils-pw\Documents\8100-TRN\City & County of Denver, CO\20-100-077-00_CCD 202055806 Connecting Auraria\00000\Bridges\Drawings\B24_BRDG_Approach-Slab02

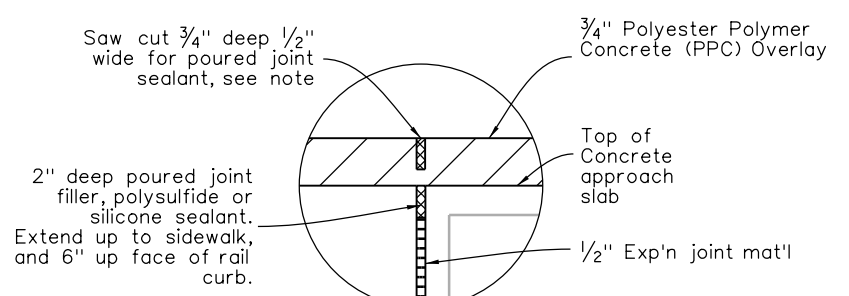
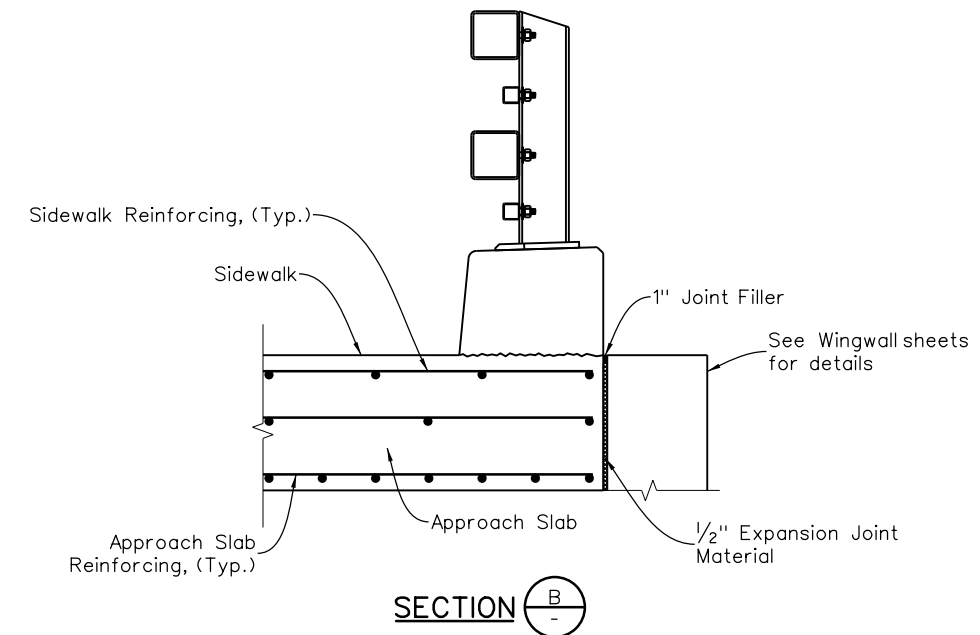
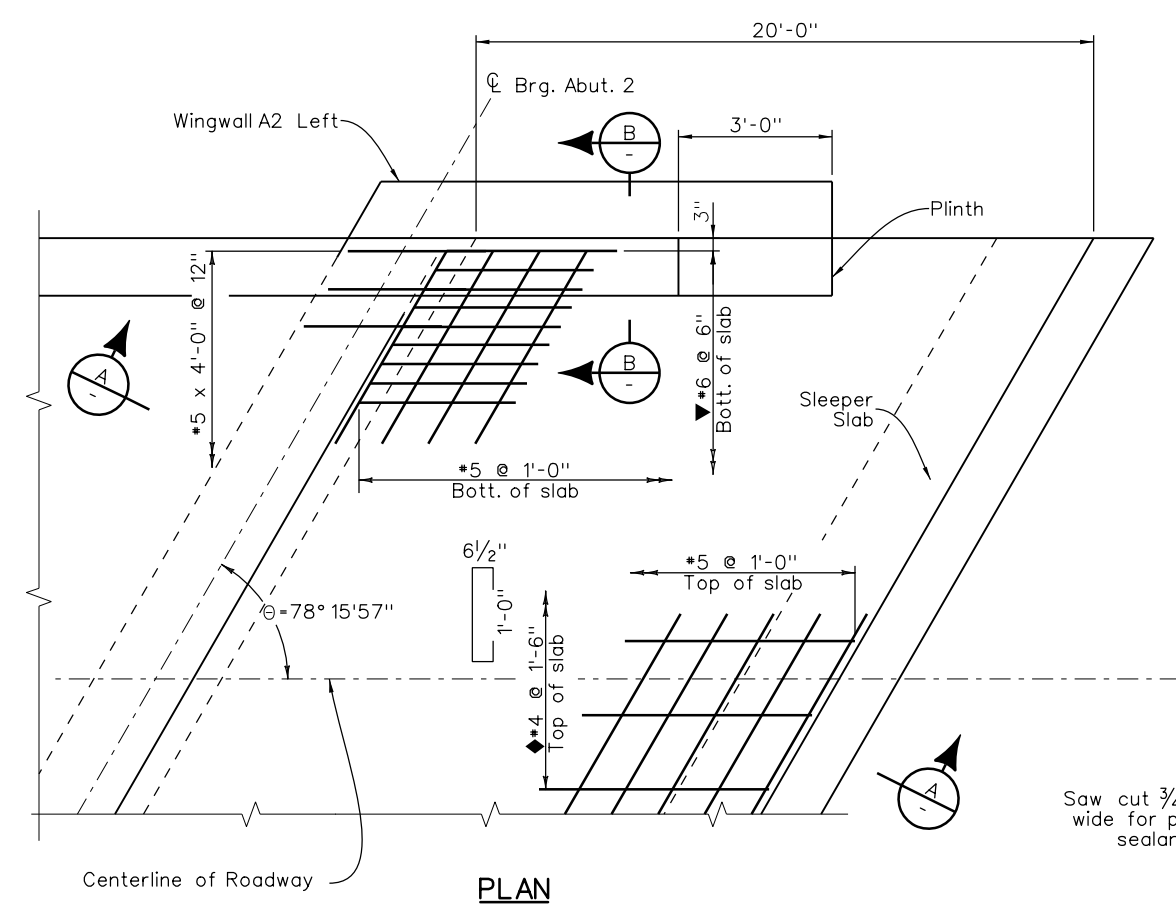

NOTES:
 Concrete (Class D) (Bridge) shall be used for approach slabs.
 Approach slab concrete shall be cured in accordance with the Specifications for Bridge Deck Concrete in Subsection 601.
 1/2" expansion joint material shall meet AASHTO Spec. M213.
 Saw cut 3/4" deep of new Polyester Polymer Concrete (PPC) Overlay for 1/2" joint sealant with backer rod. The joint sealant with backer rod shall be included in Item 519, Place Thin Bonded Overlay (Polyester Concrete).
 No horizontal construction joint between the approach slab and sidewalk will be allowed. This may require a longitudinal, vertical construction joint similar to the deck.

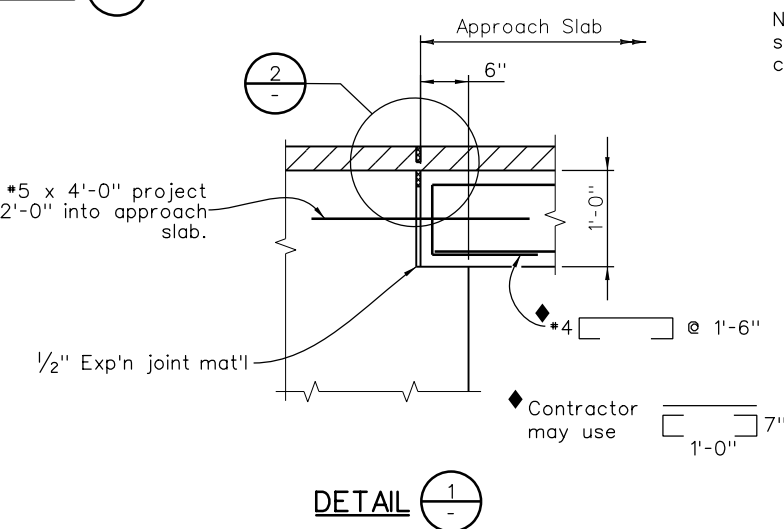
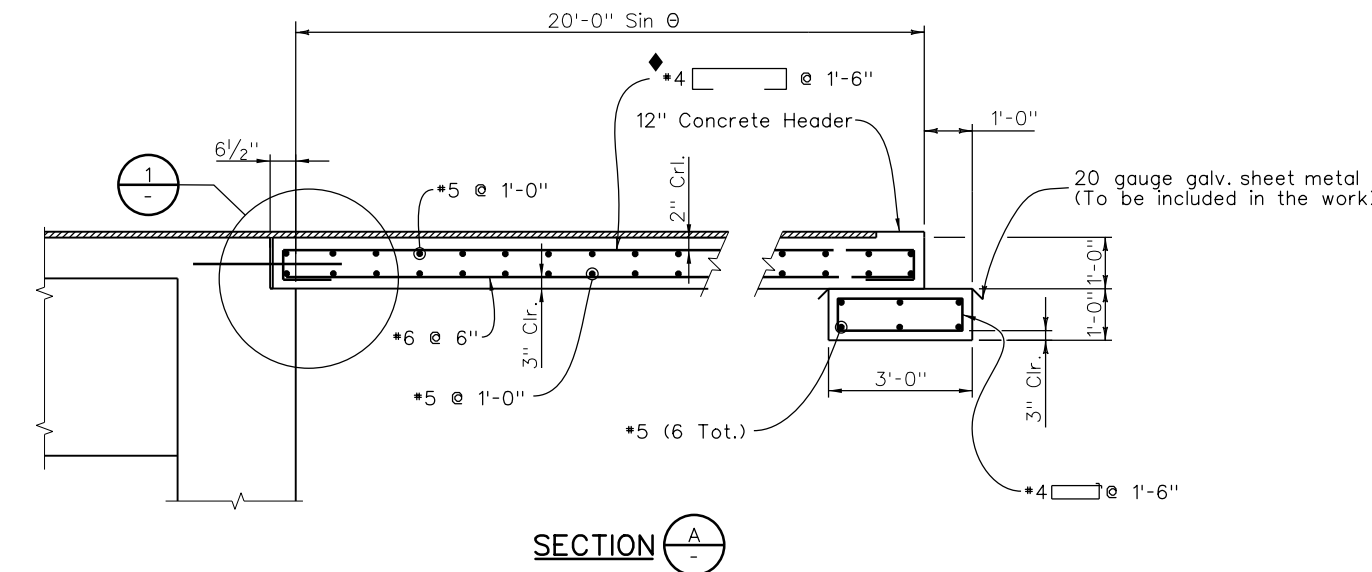

| | |
|--|--|
| Print Date: 6/27/2022 | |
| File Name: B24_BRDG_Approach-Slab02 | |
| Horiz. Scale: 1:1 Vert. Scale: As Noted | |
| Unit Information Unit Leader Initials | |

| Sheet Revisions | | |
|-----------------|-------------|-------|
| Date: | Comments | Init. |
| 6-27-22 | Addendum #1 | MCH |

DEPARTMENT OF TRANSPORTATION & INFRASTRUCTURE
 201 WEST COLFAX AVENUE
 DENVER, CO 80202
 PHONE: (720) 913-4501
 FAX: (720) 913-4544

| |
|----------------|
| As Constructed |
| No Revisions: |
| Revised: |
| Void: |

| APPROACH SLAB 2 | | | |
|-----------------|------------|-------------------|--------------|
| Designer: | M. Hildahl | Structure Numbers | D-01-CC-050A |
| Detailer: | C. Fisher | Sheet Subset: | BRIDGE |
| | | Subset Sheets: | B24 of B30 |

| | |
|------------------|-------------------|
| Project No./Code | DOTI-202055806-00 |
| Sheet Number | 76 |

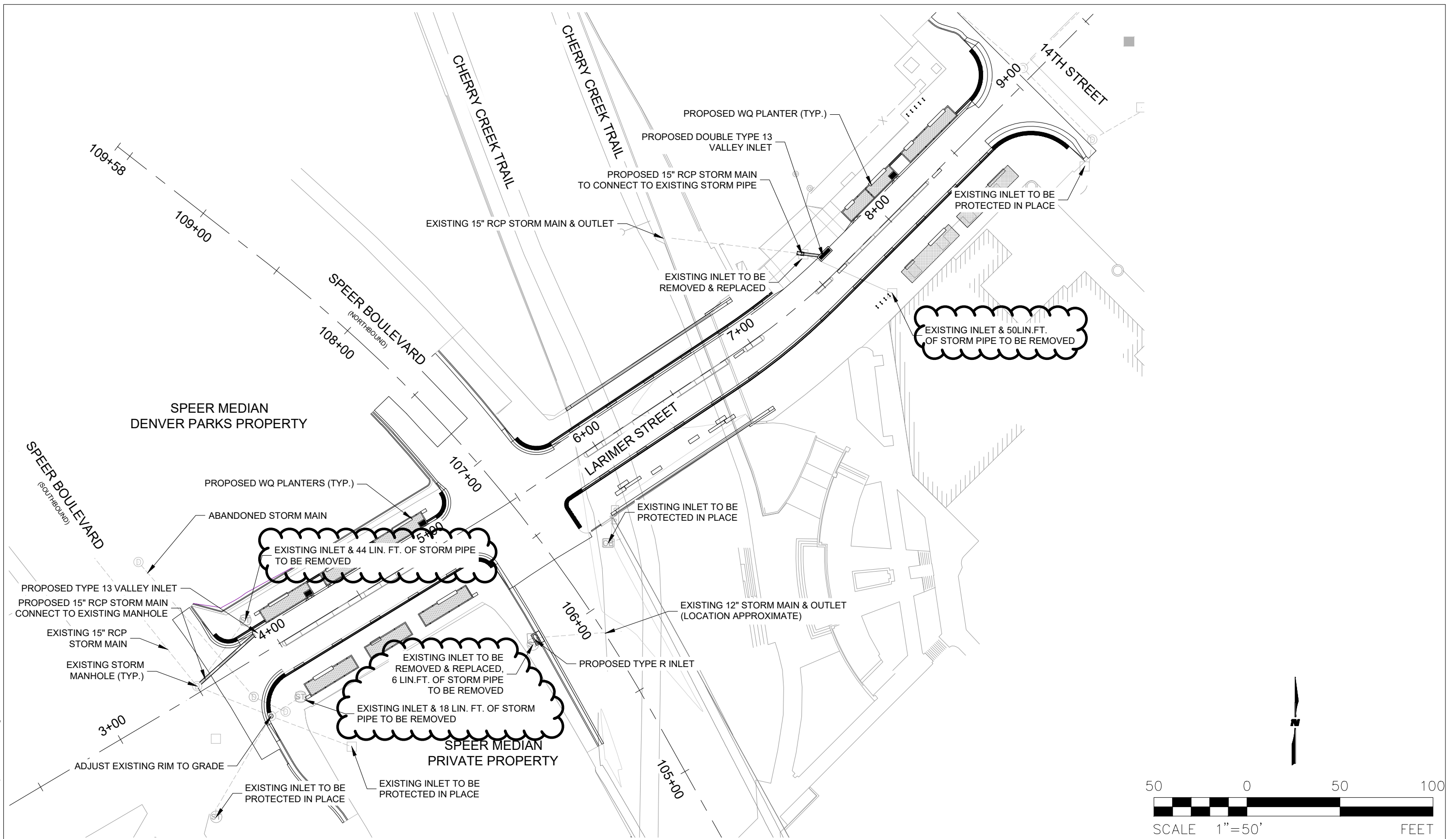

Print Date: 5/18/2022
 File Name: Proposed Storm Improvements.dwg
 Horiz. Scale: Vert. Scale: As Noted

| Sheet Revisions | | |
|-----------------|-------------|-------|
| Date: | Comments | Init. |
| 6/28/2022 | ADDENDUM #1 | BDB |
| | | |
| | | |

DEPARTMENT OF TRANSPORTATION & INFRASTRUCTURE
 201 WEST COLFAX AVENUE
 DENVER, CO 80202
 PHONE: (720) 913-4501
 FAX: (720) 913-4544

As Constructed
 No Revisions:
 Revised:
 Void:

PROPOSED STORM IMPROVEMENTS OVERALL

| | | |
|---------------|-------|-------------------------|
| Designer: | BDB | Structure |
| Detailer: | LML | Numbers |
| Sheet Subset: | STORM | Subset Sheets: 01 of 05 |



Project No./Code
 Sheet Number **83**

C:\wip\100456249\Proposed Storm Improvements.dwg

WILSON & COMPANY
 ENGINEERS & ARCHITECTS
 990 S Broadway, Suite 220
 Denver, CO 80209
 (303) 297-2976 main
 (303) 297-2693 fax
 www.wilsonco.com

| TABULATION OF STORM IMPROVEMENT ITEMS | | | | | |
|---------------------------------------|------------------------------------|------|---------|---------|-------|
| ITEM NUMBER | DESCRIPTION | UNIT | INITIAL | INTERIM | TOTAL |
| 202-00019 | REMOVAL OF AN INLET | EA | 5 | | 5 |
| 210-04010 | ADJUST MANHOLE | EA | | 2 | 2 |
| 603-01155 | 15" REINFORCED CONCRETE PIPE (CIP) | LF | | 54 | 54 |
| 604-13505 | INLET TYPE 13 (DOUBLE) (5 FOOT) | EA | | 1 | 1 |
| 604-13005 | INLET TYPE 13 (5 FOOT) | EA | | 1 | 1 |
| 604-19110 | INLET TYPE R L 5 (10 FOOT) | EA | | 1 | 1 |
| 605- | CONCRETE COLLAR | EA | | 1 | 1 |
| 202-00035 | STORM PIPE REMOVAL | LF | 118 | | 118 |

C:\wip\100456249\Proposed Storm Improvements.dwg

| | | | | | | | | |
|--|--|-------------|----------|--|----------------|--|-------------------------|------------------------|
| Print Date: 5/18/2022 | Sheet Revisions | | |  DEPARTMENT OF TRANSPORTATION & INFRASTRUCTURE 201 WEST COLFAX AVENUE DENVER, CO 80202 PHONE: (720) 913-4501 FAX: (720) 913-4544 | As Constructed | PROPOSED STORM IMPROVEMENTS COST DATA | | Project No./Code |
| | File Name: Proposed Storm Improvements.dwg | Date: | Comments | | | | | |
| Horiz. Scale: Vert. Scale: As Noted | 6/28/2022 | ADDENDUM #1 | BDB | | Revised: | Designer: BDB | Structure | |
|  990 S Broadway, Suite 220 Denver, CO 80209 (303) 297-2976 main (303) 297-2693 fax www.wilsonco.com | | | | | Void: | Detailer: LML | Numbers | |
| | | | | | | Sheet Subset: STORM | Subset Sheets: 02 of 05 | Sheet Number 84 |

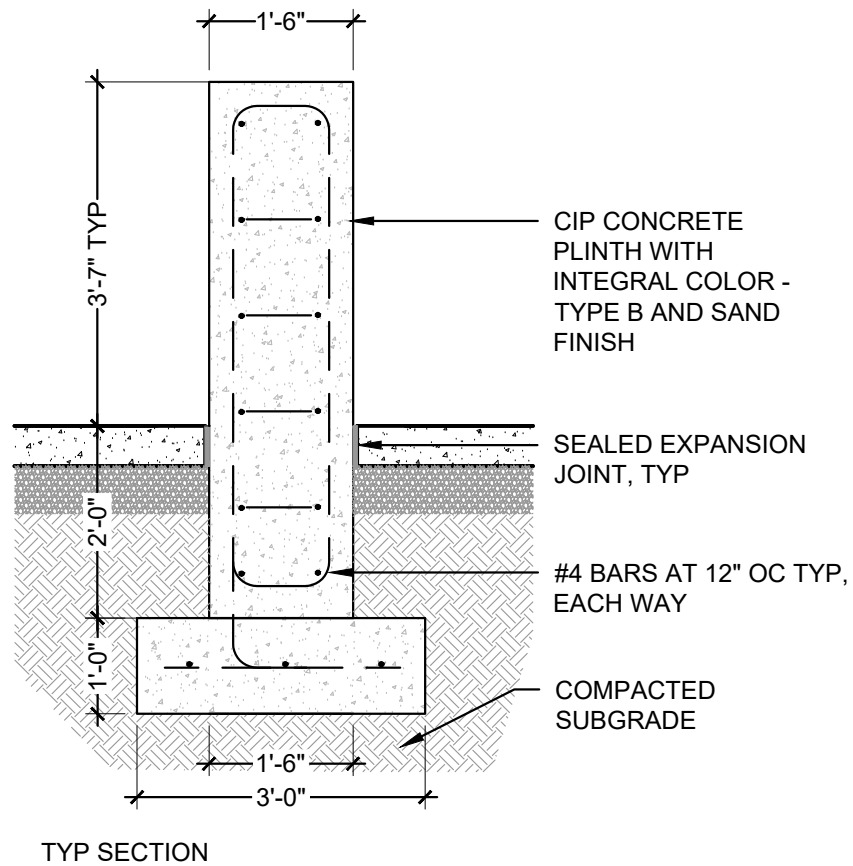
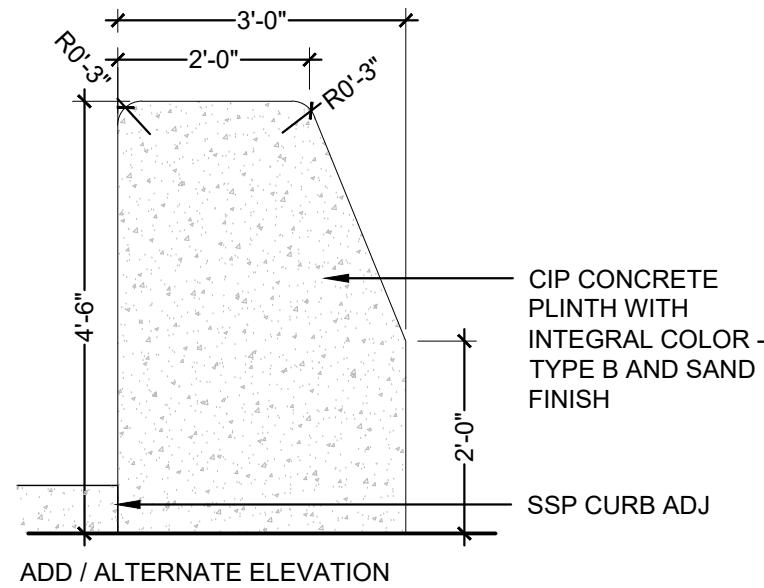
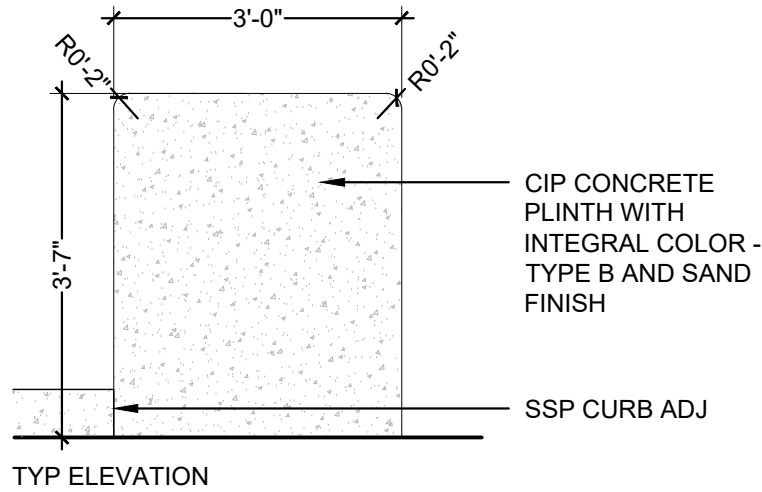

BASIS OF PAYMENT
 CONCRETE MONUMENTS THAT ARE LOCATED WITHIN THE SPEER MEDIAN ARE TO BE PAID FOR AS CONCRETE CLASS D (BRIDGE) = 6CY AND REINFORCING STEEL (EPOXY COATED) = 405 LBS.

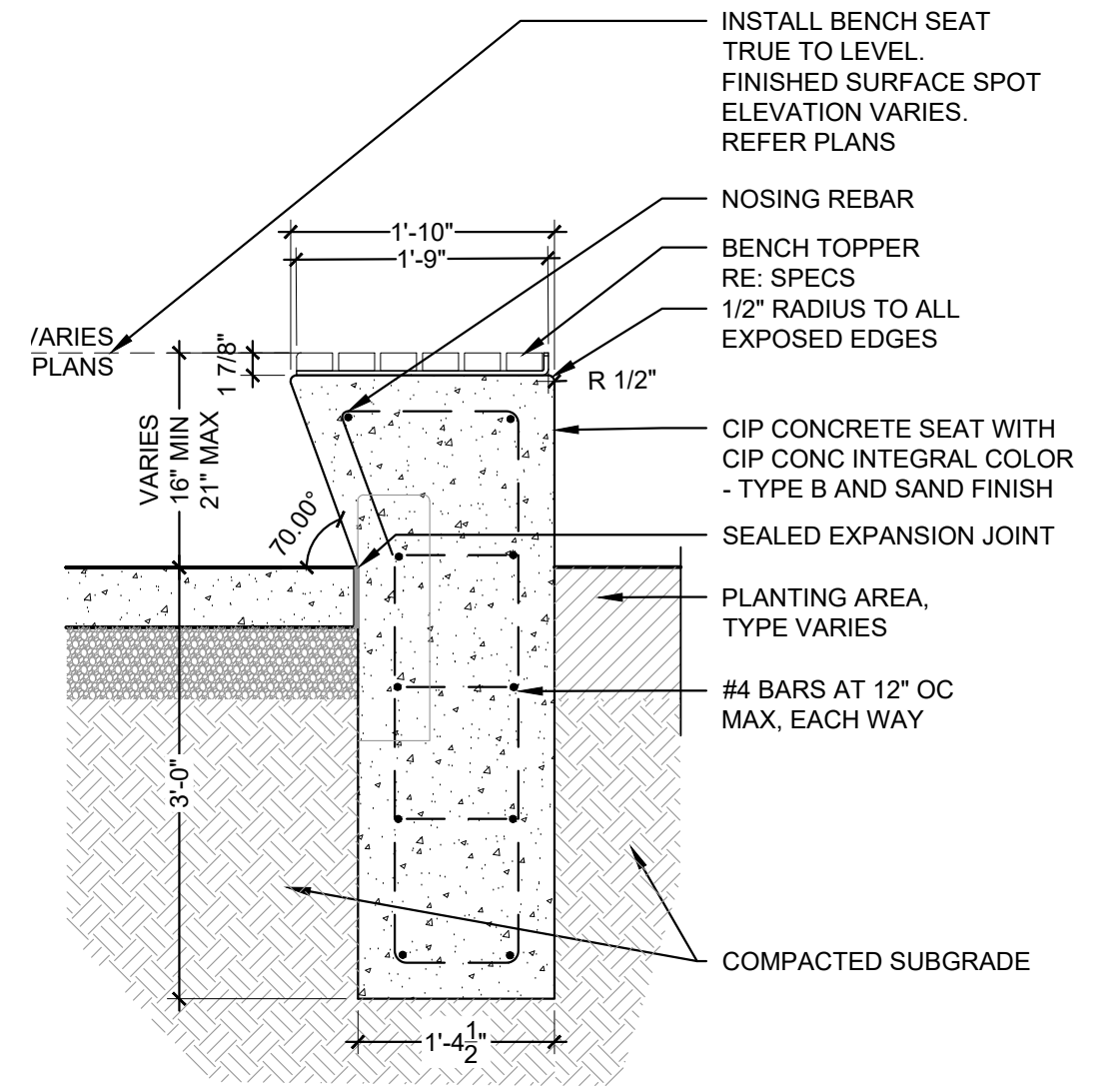

2 CONCRETE PLINTH (IN BETWEEN NORTHBOUND & SOUTHBOUND SPEER)
 SCALE: 1/2" = 1'

1 CIP CONCRETE BENCH SEAT
 SCALE: 3/4" = 1'

| | | | | | | | | |
|--|-----------------------|-----------------------|----------|---|-------------------------|---------------------------------|-------------------|------------------|
| Print Date: 5/20/2022 | Sheet Revisions | | | DEPARTMENT OF TRANSPORTATION & INFRASTRUCTURE 201 WEST COLFAX AVENUE DENVER, CO 80202 PHONE: (720) 913-4501 FAX: (720) 913-4544 | As Constructed | CONNECTING AURARIA SITE DETAILS | | Project No./Code |
| File Name: Connecting Auraria_Landscape.dwg | Date: 6/28/22 | Comments: ADDENDUM #1 | Init: MS | | No Revisions: | Designer: MSS | Structure Numbers | |
| Horiz. Scale: Not to Scale | Vert. Scale: As Noted | | | Revised: | Detailer: MSS | | | |
| 3858 Walnut St. #135 Denver, CO 80205 Phone: 303.800.2201 www.livablecitiesstudio.com | | | | Void: | Sheet Subset: LANDSCAPE | Subset Sheets: L16 of L23 | Sheet Number 108 | |

GENERAL NOTES

1. ALL WORK TO BE COORDINATED WITH XCEL AND DONE TO XCEL STANDARDS PER XCEL'S FINAL DESIGN.
2. ALL WORK SHALL BE IN ACCORDANCE WITH CURRENTLY ADOPTED NATIONAL ELECTRIC CODE (NEC) AND LOCAL CODES.
3. DATA PRESENTED ON THESE DRAWINGS ARE AS ACCURATE AS PLANNING CAN DETERMINE, BUT FIELD VERIFICATION OF ALL DIMENSIONS, LOCATIONS, LEVELS, ETC. TO SUIT FIELD CONDITIONS IS REQUIRED. REVIEW ALL CIVIL DETAILS AND ADJUST WORK TO MEET THE REQUIREMENTS OF CONDITIONS SHOWN. DISCREPANCIES BETWEEN DIFFERENT PLANS OR BETWEEN DRAWINGS AND SPECIFICATIONS, OR REGULATIONS AND CODES GOVERNING THE INSTALLATION SHALL BE BROUGHT TO THE ATTENTION OF THE ENGINEER IN WRITING.
4. ALL WORK SHALL BE COMPLETED IN A NEAT AND WORKMANLIKE MANNER AND IN ACCORDANCE WITH NECA AND XCEL STANDARDS.
5. ALL WORK SHALL BE SUBJECT TO INSPECTION AND POSSIBLE REJECTION IF NOT IN ACCORDANCE WITH THE DRAWINGS AND SPECIFICATIONS AND INSTALLED IN A NEAT AND WORKMANLIKE MANNER.
6. ANY REJECTED WORK SHALL BE REPLACED AT NO ADDITIONAL COST TO THE OWNER.
7. PROVIDE REPRODUCIBLE RECORD DRAWINGS OF ALL COMPLETED WORK.
8. MINIMUM SEPARATIONS FOR OTHER UTILITIES ARE AS FOLLOWS UNLESS OTHERWISE REQUIRED BY THE LOCAL UTILITIES. POWER OR OTHER FOREIGN CONDUIT: 3" CONCRETE, 4" MASONRY, 12" WELL TAMPED EARTH. PIPES (OIL, GAS, ETC.) 6" WHEN CROSSING, 12" WHEN PARALLEL. STORM DRAIN: 6" WHEN CROSSING, 12" WHEN PARALLEL. WATER, SANITARY SEWER: 18" WHEN CROSSING, 5' WHEN PARALLEL.
9. IT IS CONTRACTORS RESPONSIBILITY TO CALL 1-800-227-2600 PRIOR TO DIGGING. IT IS ALSO THE CONTRACTORS RESPONSIBILITY TO LOCATE ALL NON-UTILITY UNDERGROUND ITEMS.
10. DAMAGE TO ANY UTILITIES SHALL BE REPLACED IMMEDIATELY IN COMPLIANCE WITH THE DAMAGED UTILITY OWNER AND INSPECTED PRIOR TO BACKFILL. THE CONTRACTOR SHALL COORDINATE WITH LOCAL UTILITIES PRIOR TO INSTALLATION OF NEW DUCTBANK.
11. THE CONTRACTOR SHALL REMOVE FROM THE JOB SITE ALL DISCARD AND ABANDONED MATERIALS FROM DEMOLITION AND INSTALLATION. THIS INCLUDES BUT IS NOT LIMITED TO CONDUIT, FASTENERS, BOXES, & ETC. MATERIALS EMBEDDED IN GRADE AND/OR CONCRETE MAY BE ABANDONED IN PLACE. ALL ABANDONED CONDUIT SHALL BE CAPPED.
12. DO NOT SPLICE FEEDER CONDUCTORS UNLESS PRIOR APPROVAL HAS BEEN OBTAINED FROM THE ENGINEER AND OWNER/PM.
13. THE MAXIMUM NUMBER OF CONDUIT BENDS SHALL NOT BE GREATER THAN 360 DEGREES BETWEEN PULLING STRUCTURES. THIS INCLUDES THE AGGREGATE OF ALL HORIZONTAL AND VERTICAL CHANGES.
14. ALL CONDUIT, INNERDUCT, PULLBOXES AND VAULTS SHALL BE PER XCEL STANDARDS.
15. COORDINATE DEMO/RELOCATION OF EXISTING ELECTRICAL DEVICES AND EQUIPMENT WITH XCEL.
16. ALL IN-GRADE JUNCTION BOXES AND LIDS SHALL BE A MINIMUM TIER 22 TYPE JUNCTION BOX PER XCEL STANDARDS.
17. MAINTAIN A COMPLETE SET OF ELECTRICAL DRAWINGS AT THE JOB SITE WITH ALL CHANGES OR VARIATIONS IN THE WORK MARKED IN A OBVIOUS MANNER. A COMPLETE AS-BUILT SET OF DRAWINGS INCORPORATING ALL MARK-UPS OF THE WORK SHALL BE DELIVERED TO THE OWNER UPON COMPLETION OF THE PROJECT.

ELECTRICAL LEGEND

- NEW STREET LIGHT STANDARD
- ⊕ NEW PEDESTRIAN LIGHT
- NEW JUNCTION BOX
- NEW IN-GRADE PULLBOX
- — — NEW UNDERGROUND CONDUIT
- NEW SURFACE MOUNTED CONDUIT
- Ⓜ NEW UNDERDECK FLOODLIGHT

L:\2020\20136 - Connecting Auraria US. CAD\PK_Connecting Auraria_Lighting Base.dwg

Print Date: 5/20/2022
 File Name: PK_Connecting Auraria_Lighting Base.dwg
 Horiz. Scale: Vert. Scale: As Noted

| Sheet Revisions | | | |
|-----------------|-------------|-------|--|
| Date: | Comments | Init. | |
| 6/28/22 | ADDENDUM #1 | RP | |
| | | | |
| | | | |
| | | | |



DEPARTMENT OF TRANSPORTATION & INFRASTRUCTURE
 201 WEST COLFAX AVENUE
 DENVER, CO 80202
 PHONE: (720) 913-4501
 FAX: (720) 913-4544

| |
|----------------|
| As Constructed |
| No Revisions: |
| Revised: |
| Void: |

| CONNECTING AURARIA ELECTRICAL LEGEND | | | |
|--------------------------------------|------------|----------------|--------|
| Designer: | RP | Structure | |
| Detailer: | MB | Numbers | |
| Sheet Subset: | Electrical | Subset Sheets: | 1 of 6 |

| |
|------------------|
| Project No./Code |
| Sheet Number |



PK Electrical, Inc
 681 Sierra Rose Dr., Ste. B | Reno, Nevada 89511 | 775.826.9010
 5305 OTC Parkway Suite 420 | Greenwood Village, Colorado 80111 | 720.481.3290
pk-electrical.com © 2008-2011 PK ELECTRICAL, INC. 20136

| Max. Fixture Height | Flush Base | | | | | |
|---------------------|------------|-------|---------------|----------|-------|---------------|
| | Option 1 | | | Option 2 | | |
| | d in. | e in. | Vertical Bars | d in. | e in. | Vertical Bars |
| 12'-0" | 18 | 51 | (4) #5 | 24 | 47 | (4) #6 |
| 16'-0" | 18 | 59 | (4) #5 | 24 | 53 | (4) #6 |
| 20'-0" | 18 | 65 | (4) #5 | 24 | 59 | (4) #6 |
| 25'-0" | 24 | 66 | (4) #6 | 30 | 62 | (6) #6 |
| 30'-0" | 24 | 74 | (4) #6 | 30 | 68 | (6) #6 |
| 35'-0" | 24 | 81 | (4) #6 | 30 | 75 | (6) #6 |

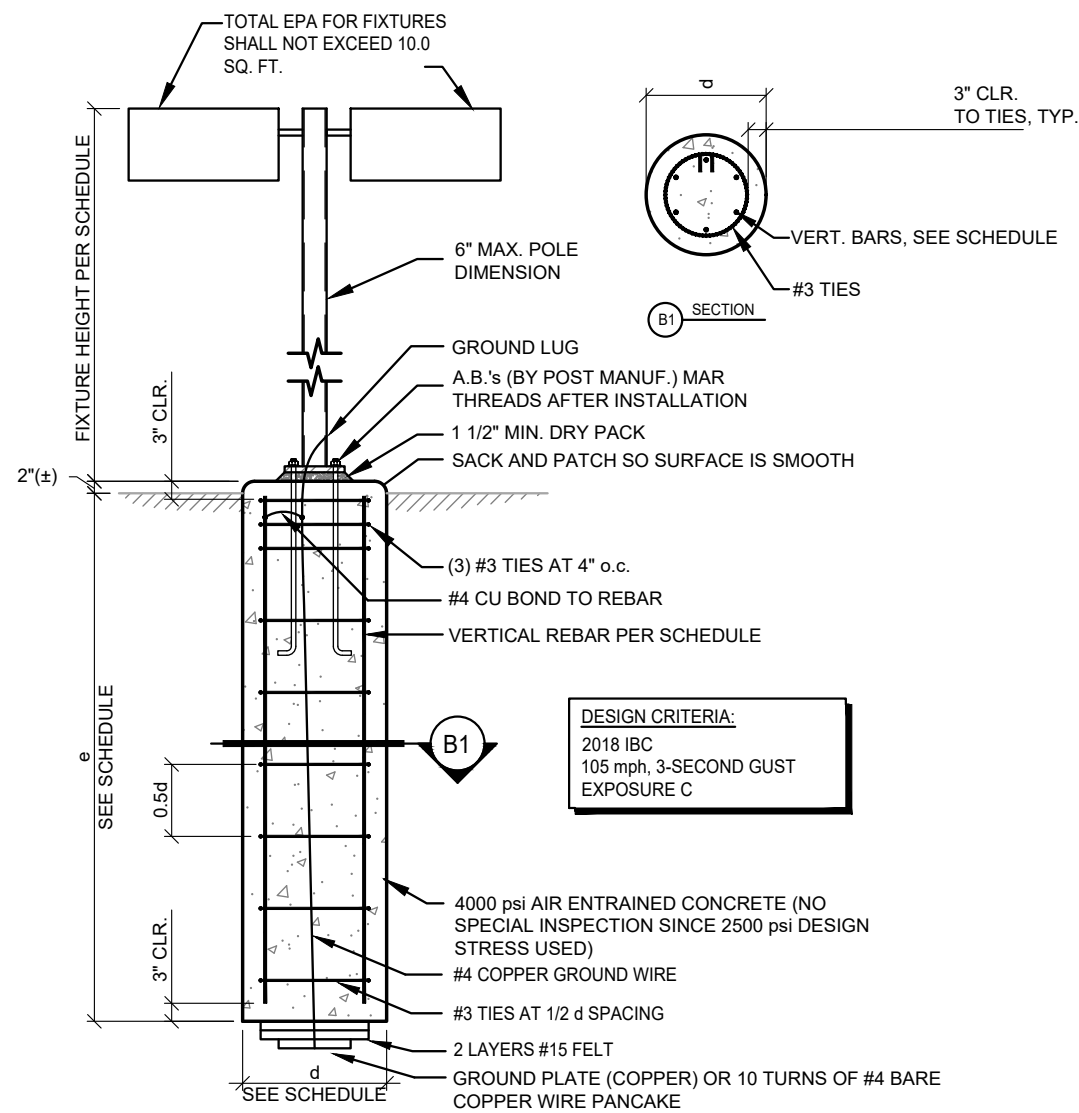

DESIGN CRITERIA:
 2018 IBC
 105 mph, 3-SECOND GUST
 EXPOSURE C

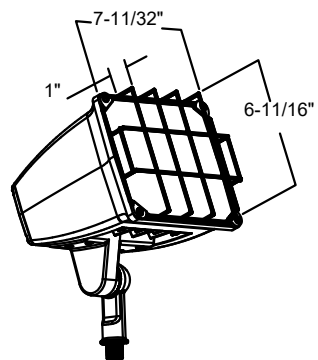

B POLE BASE - FLUSH
 SCALE: NONE

A WIRE GUARD DETAIL
 SCALE: NONE

LIGHTING FIXTURE SCHEDULE

LIGHTING FIXTURE CATALOG NUMBERS ARE SERIES TYPE ONLY. PROVIDE TRIMS, BALLASTS, MOUNTING EQUIPMENT, FITTINGS AND LAMPS AS REQUIRED BY THE SPECIFICATIONS AND PROJECT CONDITIONS FOR A COMPLETE INSTALLATION. THIS IS NOT A STANDALONE SCHEDULE AND FIXTURES MUST INCORPORATE ALL WORK INDICATED OR IMPLIED THROUGHOUT THE DRAWINGS AND SPECIFICATIONS.

- SUBSTITUTION: DEFINITIONS**
- OR EQUAL = EQUAL OR SUPERIOR TO SPECIFIED IN ALL RESPECTS WILL BE ALLOWED. ENGINEER'S PRE-BID APPROVAL IS NOT REQUIRED. PROPOSED EQUAL FIXTURES ARE SUBJECT TO REVIEW DURING THE STANDARD SUBMITTAL PROCESS.
 - NO EQUAL = PROVIDE SPECIFIED FIXTURE. SUBSTITUTIONS ARE NOT ALLOWED.
 - SUBJECT TO REVIEW = EQUAL OR SUPERIOR TO SPECIFIED IN ALL RESPECTS MAY BE ALLOWED ONLY WITH ENGINEER'S APPROVAL. ALL SUBSTITUTIONS MUST BE SUBMITTED AS REQUIRED BY SPECIFICATIONS AND ACCOMPANIED WITH POINT BY POINT LIGHTING CALCULATIONS. DETERMINATION OF EQUAL IS ENGINEER'S SOLE DISCRETION.

| TYPE | SYMBOL | DESCRIPTION AND MANUFACTURER |
|------|--------|--|
| P1 | ⊕ | MODERN LED POST TOP PEDESTRIAN LIGHT, 14' ROUND TAPERED POLE UR20-24L-25-3K7-3-UNV-PT34-RAL9017-7PR LAMP: LED, 3000K, 3000 LUMENS, TYPE 3 VOLTAGE: MVOLT MANUFACTURER: KIM LIGHTING SUBSTITUTIONS: ● OR EQUAL ○ SUBJECT TO REVIEW ○ NO EQUAL |
| P2 | ⊕ | MODERN LED POST TOP PEDESTRIAN LIGHT, 16' ROUND TAPERED POLE UR20-24L-25-3K7-3-UNV-PT34-RAL9017-7PR LAMP: LED, 3000K, 3000 LUMENS, TYPE 3 VOLTAGE: MVOLT MANUFACTURER: KIM LIGHTING SUBSTITUTIONS: ● OR EQUAL ○ SUBJECT TO REVIEW ○ NO EQUAL |
| P3 | ⊕ | LED COBRAHEAD, 4900 LUMENS, 5' ARM, 25' ROUND TAPERED STEEL POLE ERL1-0-05-C3-30-E-BLCK LAMP: LED, 3000K, 4900 LUMENS, TYPE 3 VOLTAGE: MVOLT MANUFACTURER: GE EVOLVE SUBSTITUTIONS: ● OR EQUAL ○ SUBJECT TO REVIEW ○ NO EQUAL |
| U1 | ⊕ | LED UTILITY FLOOD SMALL, SURFACE TRUNION MOUNTED, AIMED TO TRAIL BAA-UFLD-S-CA1-20-730-U-66-T-BK-WGLW/NFFLD LAMP: LED, 3000K, 3000 LUMENS VOLTAGE: MVOLT MANUFACTURER: COOPER LIGHTING STREETWORKS SUBSTITUTIONS: ● OR EQUAL ○ SUBJECT TO REVIEW ○ NO EQUAL |

Master Item Code Book - Spec Year 05
 COLORADO Department of Transportation
 08/20/2020

| Item Number | Description | Units | Total |
|-------------|--|-------|-------|
| 613-00100 | 1 Inch Electrical Conduit (PVC) | LF | 100 |
| 613-00102 | 1 Inch Electrical Conduit (Galvanized Rigid Conduit) (Special) | LF | 100 |
| 613-07000* | Pull Box (Special) | EACH | 1 |
| 613-07010* | Pull Box (Surface Mounted) | EACH | 2 |
| 613-15000* | Floodlight | EACH | 4 |
| 613-30005* | Light Standard and Luminaire (Pedestrian) | EACH | 12 |
| 613-34250* | Light Standard Metal (25 Foot) | EACH | 1 |

* FOR INFORMATION ONLY. WORK TO BE PERFORMED BY XCEL, CONTRACTOR TO COORDINATE THE WORK.

1/2020/20136 - Connecting Auraria US. CAD/PK_Connecting Auraria_Lighting Base.dwg
 20136

Print Date: 5/20/2022
 File Name: PK_Connecting Auraria_Lighting Base.dwg
 Horiz. Scale: Vert. Scale: As Noted

| Sheet Revisions | | | |
|-----------------|-------------|-------|----|
| Date: | Comments | Init. | RP |
| 6/28/22 | ADDENDUM #1 | | |

DEPARTMENT OF TRANSPORTATION & INFRASTRUCTURE
 201 WEST COLFAX AVENUE
 DENVER, CO 80202
 PHONE: (720) 913-4501
 FAX: (720) 913-4544

As Constructed
 No Revisions:
 Revised:
 Void:

CONNECTING AURARIA FIXTURE SCHEDULE AND DETAILS

Designer: RP
 Detailer: MB
 Sheet Subset: Electrical
 Structure Numbers:
 Subset Sheets: 6 of 6

Project No./Code
 Sheet Number 144

| UTILITY MATRIX | | | | | | | | | | |
|-----------------------|--------------|---------------|---|------------------------------------|--|---|---|--|-----------------------------|--|
| EXISTING UTILITY DATA | | | | | CONFLICT DATA AND RESOLUTION | | | | | |
| UTILITY ID NO. | UTILITY TYPE | UTILITY OWNER | LOCATION | Overhead (OH), or Underground (UG) | COMMENTS | UTILITY IN CONFLICT WITH | PROPOSED RESOLUTION | DESIGN & CONSTRUCTION | COST | REMARKS/WORK REQUIRED |
| | | | Roadway / Intersection | | Notes on Detail Information (Abandoned, Environmental, etc.) | (Bridge, C/F, Drainage, Roadway, Bikeway, Wall, etc.) | (Protect-in-Place, Abandon, Encase, Remove, Relocate, Reconfigure, Lower, etc.) | Design & Construction by Contractor or Utility Owner | Contractor or Utility Owner | Notes on Relocation |
| AT&T-FO-101 | FO | AT&T | 14th St. | UG | | Roadway | Protect In Place | Contractor | Contractor | AT&T duct bank is a few inches below existing pavement in flow line. |
| CCD-E-101 | E | CCD | Larimer St. between Speer Blvd. | UG | Traffic Electric | Sidewalk/Roadway | Remove | Xcel | Xcel | Xcel will remove existing Xcel owned traffic signal and electrical feed. The Contractor will install the new City owned traffic signal and electrical feed. See Signal Plans. |
| CCD-E-102 | E | CCD | Larimer St. between Speer Blvd. | UG | Traffic Electric | Sidewalk/Roadway | Remove | Xcel | Xcel | Xcel will remove existing Xcel owned traffic signal and electrical feed. The Contractor will install the new City owned traffic signal and electrical feed. See Signal Plans. |
| CCD-E-103 | E | CCD | Crossing Larimer St. at Speer Blvd. | UG | Traffic Electric | Sidewalk/Roadway | Remove | Xcel | Xcel | Xcel will remove existing Xcel owned traffic signal and electrical feed. The Contractor will install the new City owned traffic signal and electrical feed. See Signal Plans. |
| CCD-E-104 | E | CCD | N. Speer Blvd. | UG | Traffic Electric | Sidewalk/Roadway | Remove | Xcel | Xcel | Xcel will remove existing Xcel owned traffic signal and electrical feed. The Contractor will install the new City owned traffic signal and electrical feed. See Signal Plans. |
| CCD-E-106 | E | CCD | Crossing Larimer St. at 14th St. | UG | Traffic Electric | Sidewalk/Roadway | Remove | Xcel | Xcel | Xcel will remove existing Xcel owned traffic signal and electrical feed. The Contractor will install the new City owned traffic signal and electrical feed. See Signal Plans. |
| CCD-E-107 | E | CCD | Larimer St. and 14th St. | UG | Traffic Electric | Sidewalk/Roadway | Remove | Xcel | Xcel | Xcel will remove existing Xcel owned traffic signal and electrical feed. The Contractor will install the new City owned traffic signal and electrical feed. See Signal Plans. |
| CCD-E-108 | E | CCD | Larimer St. and Cherry Creek | UG | Traffic Signal Pole | Bridge | Remove | Xcel | Xcel | Xcel will remove existing Xcel owned traffic signal and electrical feed. The Contractor will install the new City owned traffic signal and electrical feed. See Signal Plans. |
| CCD-E-109 | E | CCD | Larimer St. and Cherry Creek | UG | Traffic Handhole | Bridge | Remove | Xcel | Xcel | Xcel will remove existing Xcel owned traffic signal and electrical feed. The Contractor will install the new City owned traffic signal and electrical feed. See Signal Plans. |
| CCD-E-110 | E | CCD | Larimer St. and Cherry Creek | UG | Traffic Signal Pole | Bridge | Remove | Xcel | Xcel | Xcel will remove existing Xcel owned traffic signal and electrical feed. The Contractor will install the new City owned traffic signal and electrical feed. See Signal Plans. |
| CCD-FO-101 | FO | CCD | Larimer St. between Speer Blvd. | UG | Traffic Fiber and Pullbox | Sidewalk | Adjust | Contractor | Contractor | Contractor to protect in place the City's traffic fiber, but adjust the pullbox to final grade. |
| CCD-FO-102 | FO | CCD | N. Speer Blvd. | UG | Traffic Fiber and Pullbox | Sidewalk/Roadway | Adjust | Contractor | Contractor | Contractor to protect in place the City's traffic fiber, but adjust the pullbox to final grade. |
| CCD-FO-103 | FO | CCD | Larimer St. between Speer Blvd. | UG | Traffic Fiber and Pullboxes | Sidewalk/Roadway | Adjust | Contractor | Contractor | Contractor to protect in place the City's traffic fiber, but adjust the pullboxes to final grade. |
| DWD-W-101 | W | DENVER WATER | 14th St. | UG | Valve Box (2) | Roadway | Adjust | Contractor | Contractor | Clean and adjust both valve boxes |
| DWD-W-102 | W | DENVER WATER | 14th St. | UG | Fire Hydrant | Sidewalk | Protect In Place | Contractor | Contractor | |
| DWD-W-103 | W | DENVER WATER | 14th St. | UG | Fire Hydrant | Sidewalk | Protect In Place | Contractor | Contractor | |
| LUM-T-101 | T | LUMEN | | UG | Abandoned | Bridge | Remove | Contractor | Contractor | Remove abandoned conduit as needed. |
| XCEL-E-101 | E | XCEL | Larimer St. between Speer Blvd. | UG | Ped Lights And Electric Feed | Sidewalk | Remove | Xcel | Xcel | Xcel will remove existing Xcel owned pedestrian lights and electrical feed. The Contractor will install new pedestrian lights to be inspected and turned over to Xcel. See Lighting plans. |
| XCEL-E-102 | E | XCEL | Larimer St. between Speer Blvd. | UG | Ped Lights And Electric Feed | Sidewalk | Remove | Xcel | Xcel | Xcel will remove existing Xcel owned pedestrian lights and electrical feed. The Contractor will install new pedestrian lights to be inspected and turned over to Xcel. See Lighting plans. |
| XCEL-E-103 | E | XCEL | N. Speer Blvd. | UG | | Roadway | Remove | Xcel | Xcel | |
| XCEL-E-104 | E | XCEL | Larimer St. between Cherry Creek and 14th St. | UG | Ped Lights And Electric Feed | Sidewalk | Remove | Xcel | Xcel | Xcel will remove existing Xcel owned pedestrian lights and electrical feed. The Contractor will install new pedestrian lights to be inspected and turned over to Xcel. See Lighting plans. |
| XCEL-E-105 | E | XCEL | Larimer St. between Cherry Creek and 14th St. | UG | Ped Lights And Electric Feed | Sidewalk | Remove | Xcel | Xcel | Xcel will remove existing Xcel owned pedestrian lights and electrical feed. The Contractor will install new pedestrian lights to be inspected and turned over to Xcel. See Lighting plans. |
| XCEL-E-106 | E | XCEL | 14th St. | UG | | Sidewalk | Protect In Place | Contractor | Contractor | |
| XCEL-E-107 | E | XCEL | Crossing Larimer near Cherry Creek | UG | Ped Lights And Electric Feed | Roadway | Remove | Xcel | Xcel | Xcel will remove existing Xcel owned pedestrian lights and electrical feed. The Contractor will install new pedestrian lights to be inspected and turned over to Xcel. See Lighting plans. |
| XCEL-E-108 | E | XCEL | Larimer St. and Cherry Creek | UG | Lighting Under the Bridge | Bridge | Remove | Xcel | Xcel | Xcel will remove existing Xcel owned underdeck lights and electrical feed. The Contractor will install new underdeck lights to be inspected and turned over to Xcel. See Lighting plans. |
| XCEL-E-109 | E | XCEL | Larimer St. between Cherry Creek and 14th St. | UG | Street Light | Sidewalk | Remove | Xcel | Xcel | Xcel will remove existing Xcel owned street light. The Contractor will install the new street light to be inspected and turned over to Xcel. See Lighting Plans. |
| XCEL-E-110 | E | XCEL | Larimer St. and NB Speer Blvd. | UG | Electric Feed to Irrigation | Sidewalk | Protect In Place | Contractor | Contractor | |
| XCEL-G-101 | G | XCEL | Larimer St. and Speer Blvd. | UG | 4" Stl Gas Main | Sidewalk/Roadway | Protect In Place | Contractor | Contractor | |
| XCEL-G-102 | G | XCEL | 14th St. | UG | 10" Stl Gas Main | Roadway | Protect In Place | Contractor | Contractor | |
| XCEL-G-103 | G | XCEL | Larimer St. between Cherry Creek and 14th St. | UG | 2" Stl Gas Main | Sidewalk | Protect In Place | Contractor | Contractor | |

LEGEND

Quality Level B

--- G(B) --- G(B) --- G(B) --- G(B) --- **Underground Gas**

--- E(B) --- E(B) --- E(B) --- E(B) --- **Underground Electric**

--- FO(B) --- FO(B) --- FO(B) --- FO(B) --- **Underground Fiber Optic**

--- TR(B) --- TR(B) --- TR(B) --- TR(B) --- **Underground Traffic**

--- T(B) --- T(B) --- T(B) --- T(B) --- **Underground Telephone**

--- W(B) --- W(B) --- W(B) --- W(B) --- **Underground Water**

Quality Level C

--- SS(C) --- SS(C) --- SS(C) --- SS(C) --- **Underground Sanitary Sewer**

--- SD(C) --- SD(C) --- SD(C) --- SD(C) --- **Underground Storm Sewer**

Quality Level D

--- FO(D) --- FO(D) --- FO(D) --- FO(D) --- **Underground Fiber Optic**

--- W(D) --- W(D) --- W(D) --- W(D) --- **Underground Water**

Proposed

⊕ **Pothole**

C:\cpcw\0456338\Connecting Auraria Utilities Plans.dwg

Print Date: 05/20/2022

File Name: Connecting Auraria Utilities Plans.dwg

Horiz. Scale: Vert. Scale: As Noted



633 17th Street, Suite 1500
Denver, CO 80202
Phone: (303) 953-0320

| Sheet Revisions | | |
|-----------------|-------------|-------|
| Date: | Comments | Init. |
| 6/28/22 | ADDENDUM #1 | JN |
| | | |
| | | |



DEPARTMENT OF TRANSPORTATION & INFRASTRUCTURE
201 WEST COLFAX AVENUE
DENVER, CO 80202
PHONE: (720) 913-4501
FAX: (720) 913-4544

| | | | | |
|----------------|-----------------------------------|-----------|----------------|------------------|
| As Constructed | CONNECTING AURARIA UTILITY MATRIX | | | Project No./Code |
| No Revisions: | Designer: | TK | Structure | |
| Revised: | Detailer: | LG | Numbers | |
| Void: | Sheet Subset: | UTILITIES | Subset Sheets: | UT01 of UT03 |
| | | | | Sheet Number 145 |

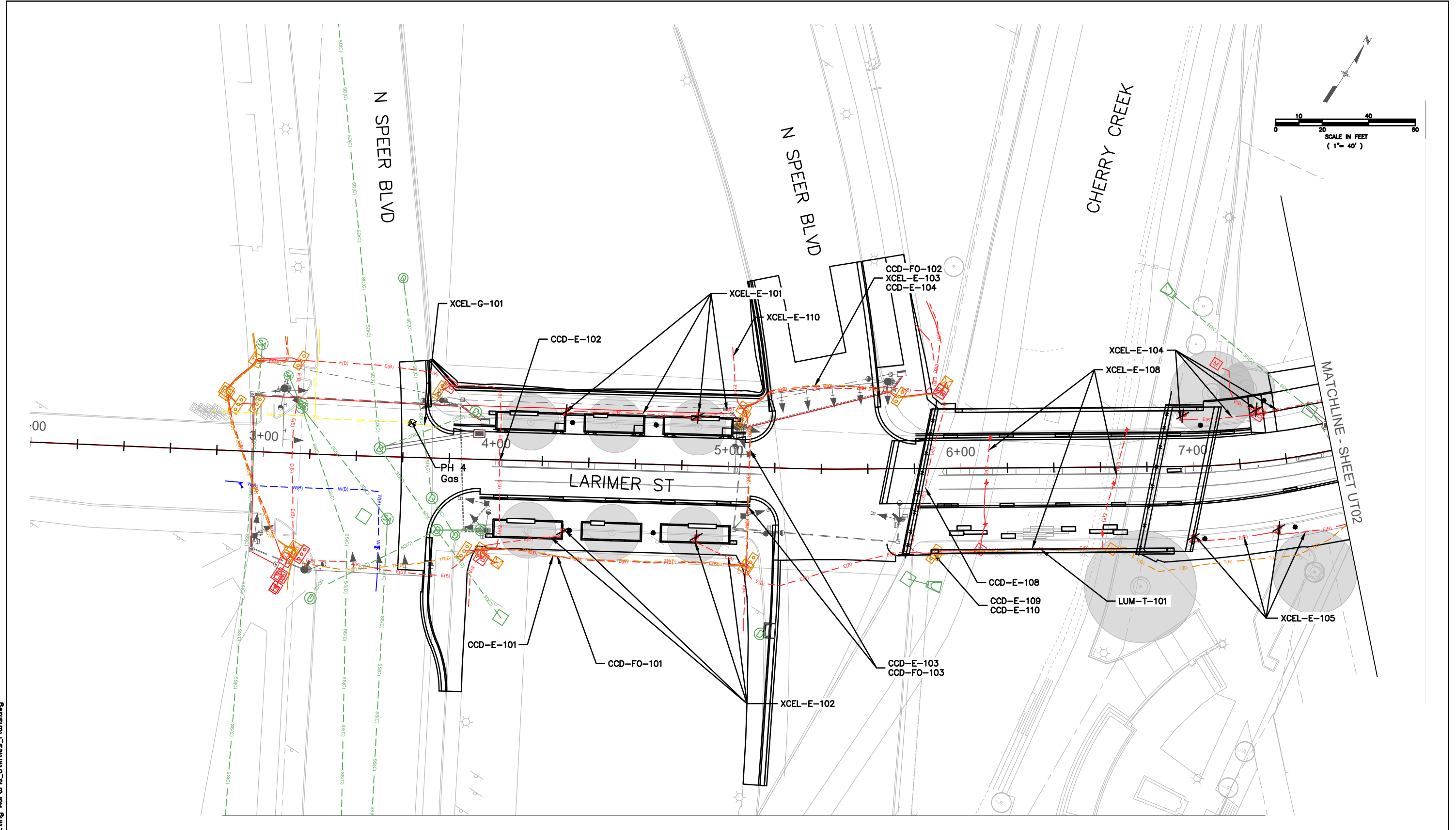

C:\wcpm\0456338\Connecting_Auraria_Utillities_Plans.dwg

Print Date: 05/20/2022
 File Name: Connecting_Auraria_Utillities_Plans.dwg
 Horiz. Scale: Vert. Scale: As Noted

| Sheet Revisions | | |
|-----------------|-------------|-------|
| Date: | Comments | Init. |
| 6/28/22 | ADDENDUM #1 | JN |
| | | |
| | | |

DEPARTMENT OF TRANSPORTATION & INFRASTRUCTURE
 201 WEST COLFAX AVENUE
 DENVER, CO 80202
 PHONE: (720) 913-4501
 FAX: (720) 913-4544

As Constructed
 No Revisions:
 Revised:
 Void:

| CONNECTING AURARIA UTILITY PLAN | | | |
|---------------------------------|-----------|----------------|--------------|
| Designer: | TK | Structure | |
| Detailer: | LG | Numbers | |
| Sheet Subset: | UTILITIES | Subset Sheets: | UT02 of UT03 |

Project No./Code
 Sheet Number 146

633 17th Street, Suite 1500
 Denver, CO 80202
 Phone: (303) 953-0320

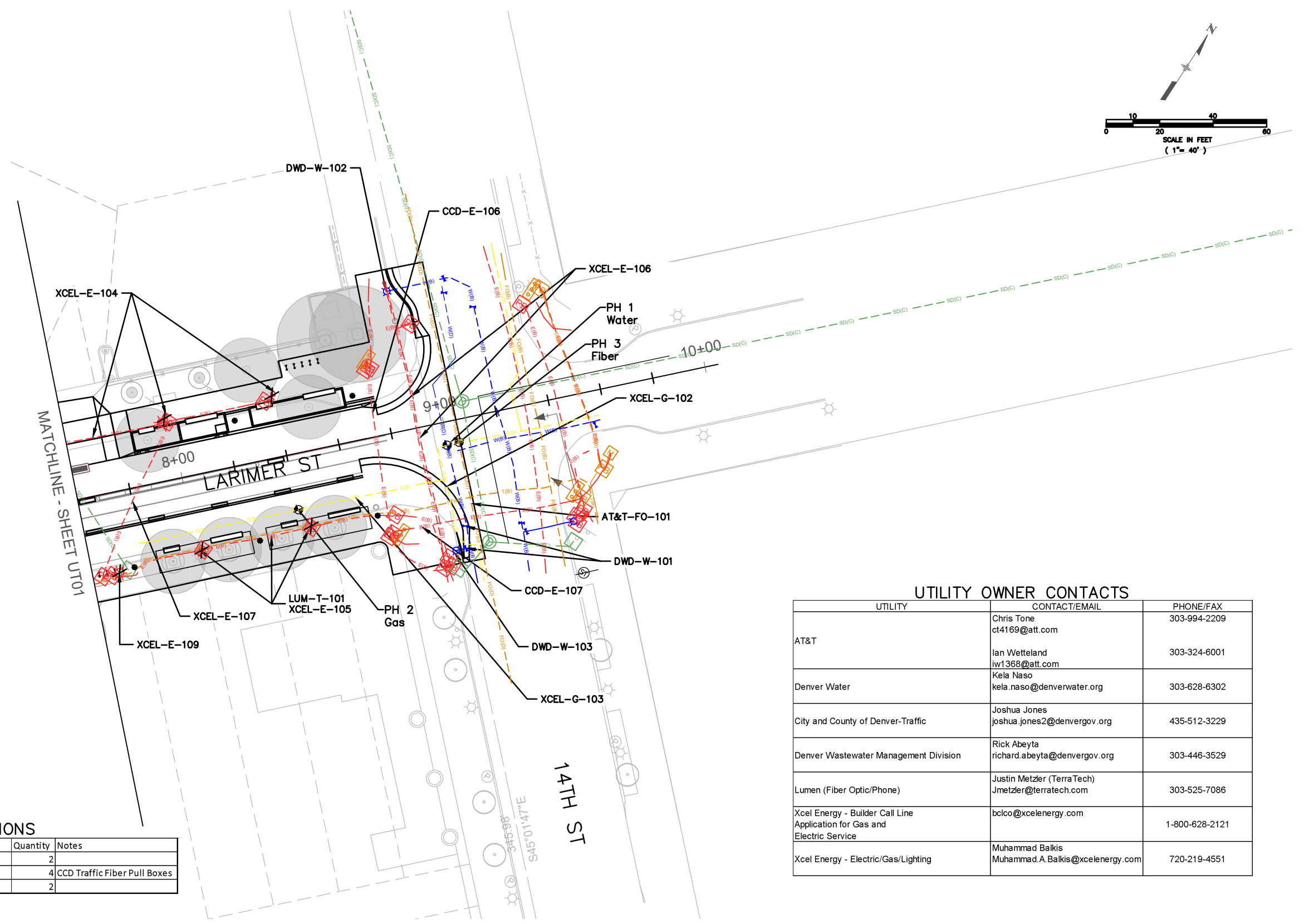
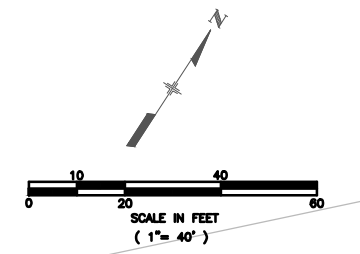

UTILITY TABULATIONS

| Item No. | Description | Unit | Quantity | Notes |
|-----------|------------------|------|----------|------------------------------|
| 202-04005 | Clean Valve Box | EACH | 2 | |
| 210-00827 | Reset Pull Box | EACH | 4 | CCD Traffic Fiber Pull Boxes |
| 210-04050 | Adjust Valve Box | EACH | 2 | |

UTILITY OWNER CONTACTS

| UTILITY | CONTACT/EMAIL | PHONE/FAX |
|--|--|----------------|
| AT&T | Chris Tone ct4169@att.com | 303-994-2209 |
| | Ian Wetteland iw1368@att.com | 303-324-6001 |
| Denver Water | Kela Naso kela.naso@denverwater.org | 303-628-6302 |
| City and County of Denver-Traffic | Joshua Jones joshua.jones2@denvergov.org | 435-512-3229 |
| Denver Wastewater Management Division | Rick Abeyta richard.abeyta@denvergov.org | 303-446-3529 |
| Lumen (Fiber Optic/Phone) | Justin Metzler (TerraTech) jmetzler@terratech.com | 303-525-7086 |
| Xcel Energy - Builder Call Line Application for Gas and Electric Service | bclco@xcelenergy.com | 1-800-628-2121 |
| Xcel Energy - Electric/Gas/Lighting | Muhammad Balkis Muhammad.A.Balkis@xcelenergy.com | 720-219-4551 |

C:\wcpm\0456338\Connecting_Auraria_Uilities_Plans.dwg

Print Date: 05/20/2022
 File Name: Connecting_Auraria_Uilities_Plans.dwg
 Horiz. Scale: Vert. Scale: As Noted

| Sheet Revisions | | |
|-----------------|-------------|-------|
| Date: | Comments | Init. |
| 6/28/22 | ADDENDUM #1 | JN |
| | | |
| | | |

DEPARTMENT OF TRANSPORTATION
 & INFRASTRUCTURE
 201 WEST COLFAX AVENUE
 DENVER, CO 80202
 PHONE: (720) 913-4501
 FAX: (720) 913-4544

| |
|----------------|
| As Constructed |
| No Revisions: |
| Revised: |
| Void: |

**CONNECTING AURARIA
 UTILITY PLAN**

| | | | |
|---------------|-----------|----------------|--------------|
| Designer: | TK | Structure | |
| Detailer: | LG | Numbers | |
| Sheet Subset: | UTILITIES | Subset Sheets: | UT03 of UT03 |

| |
|------------------|
| Project No./Code |
| Sheet Number |

147

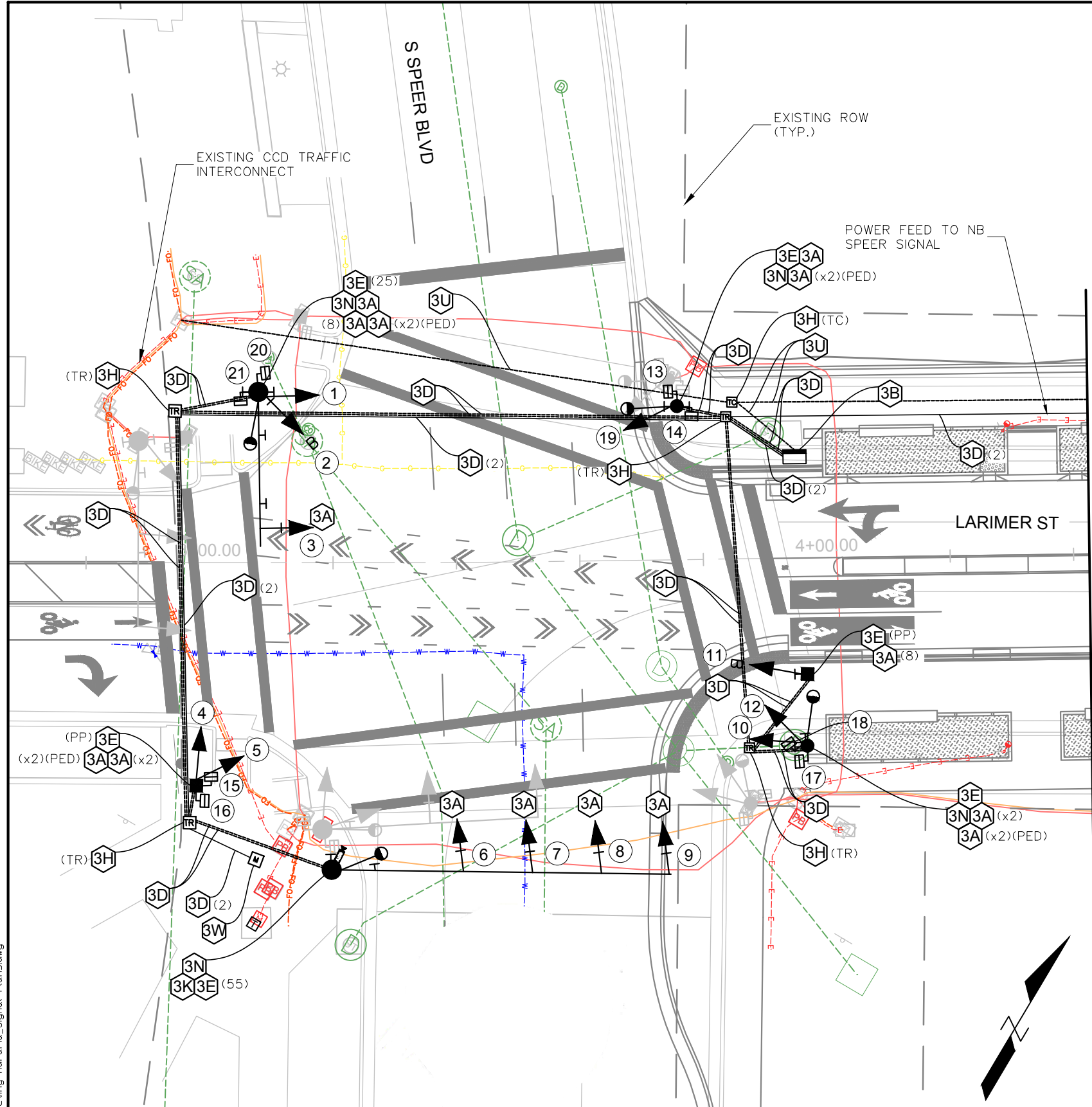

MATCHLINE STA. 4+42.60

| ITEM NO. | KEY | ITEM | UNIT | QUANTITY |
|-----------|------------|--|------|----------|
| 503-00024 | | DRILLED SHAFT (24 INCH) | LF | 14 |
| 503-00036 | | DRILLED SHAFT (36 INCH) | LF | 26 |
| 613-00200 | (3D) (2) | 2 INCH ELECTRIC CONDUIT | LF | 233 |
| 613-00300 | (3D) | 3 INCH ELECTRIC CONDUIT | LF | 572 |
| 613 | (3U) | INTERCONNECT 3-INCH ELECTRIC CONDUIT | LF | 160 |
| 613 | (3H) (TR) | PULL BOX TYPE B (TRAFFIC) | EA | 4 |
| 613 | (3H) (TC) | PULL BOX TYPE C (TRAFFIC COMM) | EA | 1 |
| 613 | (3N) | LUMINAIRE (LED) (5300 LUMENS)(55 WATT) | EA | 4 |
| 613-10000 | | WIRING | LS | 1 |
| 613-50109 | (3W) | ELECTRIC METER PEDESTAL CABINET AND BASE | EA | 1 |
| 614-70117 | (3A) (PED) | PEDESTRIAN SIGNAL FACE (16) | EA | 8 |
| 614-70324 | (3A) (8) | TRAFFIC SIGNAL FACE (8-8-8) | EA | 2 |
| 614-70336 | (3A) | TRAFFIC SIGNAL FACE (12-12-12) | EA | 11 |
| 614-72855 | (3B) | TRAFFIC SIGNAL CONTROLLER CABINET | EA | 1 |
| 614-81000 | (3E) | TRAFFIC SIGNAL-LIGHT POLE STEEL | EA | 2 |
| 614-81125 | (3E) (25) | TRAFFIC SIGNAL-LIGHT POLE STEEL (1-25 FOOT MAST ARM) | EA | 1 |
| 614-81155 | (3E) (55) | TRAFFIC SIGNAL-LIGHT POLE STEEL (1-55 FOOT MAST ARM) | EA | 1 |
| 614-84100 | (3E) (PP) | TRAFFIC SIGNAL PEDESTAL POLE ALUMINUM | EA | 2 |
| 614-86105 | | TELEMETRY (FIELD) | EA | 1 |
| 614 | | EMERGENCY VEHICLE TRAFFIC SIGNAL PRIORITY CONTROL SYSTEM | EA | 1 |
| 614-87333 | (3K) | CLOSED CIRCUIT TELEVISION CAMERA (TRAFFIC SURVEILLANCE) | EA | 1 |

SIGNAL HEAD LEGEND

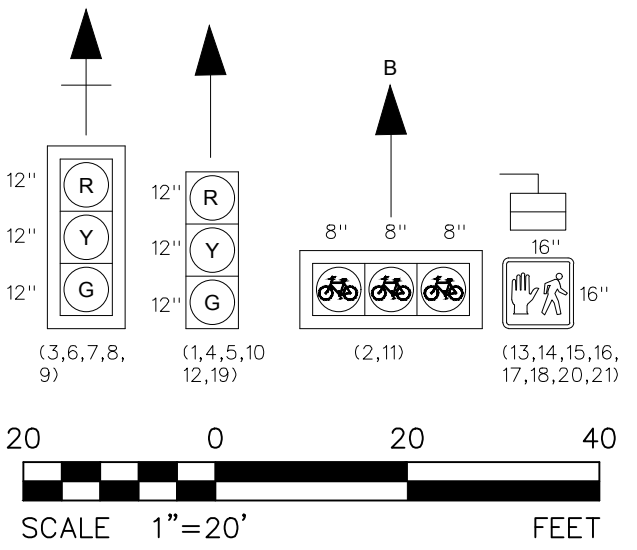

PHASE DIAGRAM

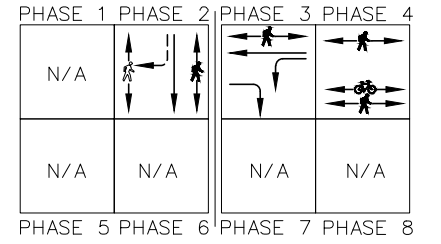

LEGEND

- TURNING MOVEMENT W/ CONFLICT
- TURNING MOVEMENT W/NO CONFLICT
- THROUGH MOVEMENT
- 2-WAY BIKE PHASE (PROTECTED)
- PED PHASE (W/ PERMITTED RIGHT TURN CONFLICT)
- PED PHASE (NO TURN CONFLICT)

Print Date: 5/18/2022
 File Name: Connecting Auraria_Signal Plans.dwg
 Horiz. Scale: 1:20 Vert. Scale: As Noted

990 S Broadway, Suite 220
 Denver, CO 80209
 (303) 297-2976 main
 (303) 297-2693 fax
 www.wilsonco.com

| Sheet Revisions | | |
|-----------------|-------------|-------|
| Date: | Comments | Init. |
| 6/28/22 | ADDENDUM #1 | DH |

DEPARTMENT OF TRANSPORTATION & INFRASTRUCTURE
 201 WEST COLFAX AVENUE
 DENVER, CO 80202
 PHONE: (720) 913-4501
 FAX: (720) 913-4544

| |
|----------------|
| As Constructed |
| No Revisions: |
| Revised: |
| Void: |

CONNECTING AURARIA TRAFFIC SIGNAL PLAN

Designer: KPM Structure:
 Detailer: KPM Numbers:
 Sheet Subset: TRAFFIC Subset Sheets: 1 of 3

Project No./Code

Sheet Number 168

C:\wip\w\0456331\Connecting_Auraria_Signal_Plans.dwg

| TABULATION OF TRAFFIC CONTROL ITEMS | | | |
|--|--|-------|----------|
| Item | Description | Units | Quantity |
| 202 | REMOVE PRE CAST MEDIANS* | LS | 1 |
| 210 | RESET PRE CAST MEDIANS** | LS | 1 |
| 403-00721 | HOT MIX ASPHALT (PATCHING) ASPHALT | SY | 800 |
| 612-00039 | DELINEATOR (FLEXIBLE) (SURFACE MOUNTED) | EA | 17 |
| 627-00008 | MODIFIED EPOXY PAVEMENT MARKING | GAL | 4 |
| 627-30405 | PREFORMED THERMOPLASTIC PAVEMENT MARKING (WORD-SYMBOL) | SF | 127 |
| FOR INFORMATION ONLY (SEE NOTE 1) | | | |
| 630-00000 | FLAGGING | HR | 480 |
| 630-00003 | UNIFORMED TRAFFIC CONTROL | HR | 16 |
| 630-00007 | TRAFFIC CONTROL INSPECTION | DAY | 70 |
| 630-00012 | TRAFFIC CONTROL MANAGEMENT | DAY | 170 |
| 630-80335 | BARRICADE (TYPE 3 M-A) (TEMPORARY) | EA | 18 |
| 630-80336 | BARRICADE (TYPE 3 M-B) (TEMPORARY) | EA | 13 |
| 630-80341 | CONSTRUCTION TRAFFIC SIGN (PANEL SIZE A) | EA | 105 |
| 630-80342 | CONSTRUCTION TRAFFIC SIGN (PANEL SIZE B) | EA | 14 |
| 630-80355 | PORTABLE MESSAGE SIGN PANEL | EA | 1 |
| 630-80357 | ADVANCE WARNING FLASHING OR SEQUENCING ARROW PANEL (B FLASH ARROW PANEL (B TY) TYPE) | EA | 5 |
| 630-80360 | DRUM CHANNELIZING DEVICE | EA | 74 |
| 630-80370 | BARRIER (TEMPORARY) | LF | 250 |

*INCLUDES REMOVAL OF REBAR ANCHORS COMPLETELY OR FLUSH WITH EXISTING PAVEMENT SURFACE

**THIS ITEM SHALL INCLUDE ALL WORK NECESSARY TO RESTORE THE 14TH ST BIKE LANE TO ITS PRE-CONSTRUCTION CONDITION AFTER COMPLETION OF THE DETOUR, INCLUDING REMOVAL OF DELINEATORS AND STRIPING

NOTE 1: CONSTRUCTION TRAFFIC CONTROL ITEMS ARE PROVIDED FOR INFORMATION ONLY AND WILL NOT BE MEASURED AND PAID FOR SEPERATELY BUT SHALL BE PAID FOR BY THE LUMP SUM ITEM "TRAFFIC CONTROL". SEE SPECIFICATIONS FOR ADDITIONAL INFORMATION.

C:\wip\p0456241\Connecting_Auraria_Tab_Sheets.dwg

Print Date: 5/18/2022
 File Name: Connecting_Auraria_Tab_Sheets.dwg
 Horiz. Scale: Vert. Scale: As Noted

WILSON & COMPANY
 ENGINEERS & ARCHITECTS
 990 S Broadway, Suite 220
 Denver, CO 80209
 (303) 297-2976 main
 (303) 297-2693 fax
 www.wilsonca.com



| Sheet Revisions | | |
|-----------------|-------------|-------|
| Date: | Comments | Init. |
| 6/28/22 | ADDENDUM #1 | DH |
| | | |
| | | |



DEPARTMENT OF TRANSPORTATION & INFRASTRUCTURE
 201 WEST COLFAX AVENUE
 DENVER, CO 80202
 PHONE: (720) 913-4501
 FAX: (720) 913-4544

| As Constructed |
|----------------|
| No Revisions: |
| Revised: |
| Void: |

| CONNECTING AURARIA TEMPORARY TRAFFIC CONTROL TABULATIONS | | |
|--|-----------------------|--|
| Designer: KPM | Structure Numbers | |
| Detailer: KPM | | |
| Sheet Subset: TTC TABS | Subset Sheets: 1 of 1 | |

| Project No./Code |
|------------------|
| |
| Sheet Number 171 |

CCD EROSION CONTROL AND STORMWATER MANAGEMENT NOTES:

- THE PERMITTEE AND/OR CONTRACTOR SHALL REMOVE ALL SEDIMENT, MUD, CONSTRUCTION DEBRIS, OR OTHER POTENTIAL POLLUTANTS THAT MAY HAVE BEEN DISCHARGED TO OR, ACCUMULATE IN, THE FLOWLINES, STORM DRAINAGE APPURTENANCES, AND PUBLIC RIGHTS OF WAYS OF THE CITY AND COUNTY OF DENVER AS A RESULT OF CONSTRUCTION ACTIVITIES ASSOCIATED WITH THIS SITE DEVELOPMENT OR CONSTRUCTION PROJECT. SAID REMOVAL SHALL BE CONDUCTED IN A TIMELY MANNER.
- THE CONTRACTOR SHALL PREVENT SEDIMENT, DEBRIS AND ALL OTHER POLLUTANTS FROM ENTERING THE STORM SEWER SYSTEM DURING ALL DEMOLITION, EXCAVATION, TRENCHING, BORING, GRADING, OR OTHER CONSTRUCTION OPERATIONS THAT ARE A PART OF THIS PROJECT. THE CONTRACTOR SHALL BE HELD RESPONSIBLE FOR REMEDIATION OF ANY ADVERSE IMPACTS TO THE MUNICIPAL SEPARATE STORM SEWER SYSTEM, RECEIVING WATERS, WATERWAYS, WETLANDS, AND OR OTHER PUBLIC OR PRIVATE PROPERTIES, RESULTING FROM WORK DONE AS PART OF THIS PROJECT.
- SOIL STABILIZATION MEASURES SHALL BE IMPLEMENTED WITHIN FOURTEEN (14) DAYS FOLLOWING COMPLETION OF GRADING ACTIVITIES. STABILIZATION OF DISTURBED AREAS ADJACENT TO RECEIVING WATERS OR WITH SLOPES THREE TO ONE (3:1) OR GREATER SHALL BE COMPLETED WITHIN SEVEN (7) DAYS FOLLOWING COMPLETION OF GRADING ACTIVITIES. NOTE: FEDERAL AND STATE REGULATIONS MAY SOON REQUIRE STABILIZATION WITHIN SEVEN (7) DAYS OF COMPLETION OF GRADING ACTIVITIES. IN SUCH CASES, THE SHORTER TIMEFRAME SHALL APPLY TO PROJECTS WITHIN DENVER AS WELL.
- THE DEVELOPER, GENERAL CONTRACTOR, GRADING CONTRACTOR AND/OR THEIR AUTHORIZED AGENTS SHALL INSURE THAT ALL LOADS OF CUT AND FILL MATERIAL IMPORTED TO OR EXPORTED FROM THIS SITE SHALL BE PROPERLY COVERED TO PREVENT LOSS OF THE MATERIAL DURING TRANSPORT ON PUBLIC RIGHTS OF WAY (SEC. 49-552; REVISED MUNICIPAL CODE).
- THE USE OF REBAR TO ANCHOR BEST MANAGEMENT PRACTICES (BMPs) IS PROHIBITED. STEEL FENCE POSTS MAY BE USED ON A CASE BY CASE BASIS AND REQUIRES APPROVAL FROM THE CITY AND COUNTY OF DENVER STORMWATER MANAGEMENT PLAN (SWMP) REVIEWER OR THE STORMWATER ENFORCEMENT INVESTIGATOR PRIOR TO INSTALLATION.
- SOILS THAT WILL BE STOCKPILED FOR MORE THAN THIRTY (30) DAYS SHALL BE PROTECTED FROM WIND AND WATER EROSION WITHIN FOURTEEN (14) DAYS OF STOCKPILE CONSTRUCTION. STABILIZATION STOCKPILES LOCATED WITHIN ONE HUNDRED (100) FEET OF RECEIVING WATERS, OR WITH SLOPES THREE TO ONE (3:1) OR GREATER SHALL BE COMPLETE WITHIN SEVEN (7) DAYS FOLLOWING STOCKPILE CONSTRUCTION. STABILIZATION AND PROTECTION OF THE STOCKPILE MAY BE ACCOMPLISHED BY ANY OF THE FOLLOWING: MULCHING, TEMPORARY/PERMANENT REVEGETATION OPERATIONS, CHEMICAL SOIL STABILIZER APPLICATION (REQUIRES DENVER PUBLIC WORKS APPROVAL), OR EROSION CONTROL MATTING/GEOTEXTILES. IF STOCKPILES ARE LOCATED WITHIN ONE HUNDRED (100) FEET OF RECEIVING WATERS, A DRAINAGEWAY OR THE SITE PERIMETER, ADDITIONAL SEDIMENT CONTROLS SUCH SHALL BE REQUIRED.
- APPROVED EROSION AND SEDIMENT CONTROL BEST MANAGEMENT PRACTICES (BMPs) SHALL BE MAINTAINED AND KEPT IN GOOD REPAIR FOR THE DURATION OF THIS PROJECT. AT A MINIMUM, THE PERMITTEE OR CONTRACTOR SHALL PRODUCE AND RETAIN WEEKLY WRITTEN INSPECTION RECORDS FOR ALL BMPs AND AFTER SIGNIFICANT PRECIPITATION EVENTS. ALL NECESSARY MAINTENANCE AND REPAIR SHALL BE COMPLETED IMMEDIATELY. ADDITIONALLY, STREET SWEEPING IS TO BE COMPLETED BY THE CLOSE OF THE BUSINESS DAY OR (AND) ON AN AS NEEDED BASIS THROUGHOUT THE DAY.
- WATER USED IN THE CLEANING OF CEMENT TRUCKS DELIVERY CHUTES SHALL BE DISCHARGED INTO A PREDEFINED, CONCRETE WASHOUT AREA ON THE JOB SITE. BERMED CONTAINMENT OR COMMERCIALY AVAILABLE CONCRETE WASHOUT DEVICES THAT FULLY CONTAIN ALL WASH WATER ARE ACCEPTABLE. WASH WATER DISCHARGED INTO THE CONTAINMENT AREA OR DEVICE SHALL BE ALLOWED TO INFILTRATE, EVAPORATE, AND OR BE DISPOSED OF IN ACCORDANCE WITH ALL APPLICABLE REGULATIONS. DRIED CEMENT WASTE IS TO BE REMOVED FROM THE CONTAINMENT AREA AND PROPERLY DISPOSED.

SHOULD THE USE OF A PREDEFINED BERMED CONTAINMENT AREA OR APPROVED WASHOUT DEVICE BE TECHNICALLY INFEASIBLE DUE TO THE PROJECT SIZE, OR LACK OF AN AREA WITH SUITABLE GROUND SURFACE FOR ESTABLISHING CONTAINMENT, PROPER DISPOSAL OF CONCRETE WASHOUT AND WASH WATER AT THE JOB SITE SHALL CONFORM TO THE APPROVED TECHNIQUES AND PRACTICES IDENTIFIED IN THE COLORADO DEPARTMENT OF PUBLIC HEALTH AND ENVIRONMENT'S TRAINING VIDEO ENTITLED 'BUILDING FOR A CLEANER ENVIRONMENT, READY MIX WASHOUT TRAINING' AND ITS ACCOMPANYING MANUAL ENTITLED, 'READY MIX WASHOUT GUIDEBOOK, VEHICLE AND EQUIPMENT WASHOUT AT CONSTRUCTION SITES.

THE DIRECT OR INDIRECT DISCHARGE OF WATER CONTAINING WASTE CEMENT TO THE STORM SEWER SYSTEM IS PROHIBITED (SEC. 56-102a,c; REVISED MUNICIPAL CODE, CITY AND COUNTY OF DENVER).

- THE CONTRACTOR SHALL PROTECT ALL STORM SEWER FACILITIES ADJACENT TO ANY LOCATION WHERE PAVEMENT CUTTING OPERATIONS INVOLVING WHEEL CUTTING, SAW CUTTING, OR ABRASIVE WATER JET CUTTING ARE TO TAKE PLACE.

THE CONTRACTOR SHALL REMOVE AND PROPERLY DISPOSE OF ALL WASTE PRODUCTS GENERATED BY SAID CUTTING OPERATIONS ON A DAILY BASIS OR AS NEEDED THROUGHOUT THE WORK DAY.

THE DISCHARGE OF ANY WATER CONTAMINATED BY WASTE PRODUCTS FROM CUTTING OPERATIONS TO THE STORM SEWER SYSTEM IS PROHIBITED (SEC 56-102a,c; REVISED MUNICIPAL CODE, CITY AND COUNTY OF DENVER).
- PAVED AND IMPERVIOUS SURFACES WHICH ARE ADJACENT TO CONSTRUCTION SITES MUST BE SWEEPED ON A DAILY BASIS AND AS NEEDED DURING THE DAY WHEN SEDIMENT AND OTHER MATERIALS ARE TRACKED OR DISCHARGED ONTO THEM. EITHER SWEEPING BY HAND OR USE OF STREET SWEEPERS IS ACCEPTABLE. STREET SWEEPERS USING WATER WHILE SWEEPING IS PREFERRED IN ORDER TO MINIMIZE DUST. FLUSHING OFF PAVED SURFACES WITH WATER IS PROHIBITED (SEC. 56-102a,c; REVISED MUNICIPAL CODE, CITY AND COUNTY OF DENVER).

ABBREVIATIONS

| | | | |
|------------|---|-------------|--------------------------|
| ASSY | ASSEMBLY | NIC | NOT IN CONTRACT |
| ASTM | AMERICAN SOCIETY OF TESTING AND MATERIALS | NO | NUMBER |
| APPROX | APPROXIMATE OR APPROXIMATELY | NOM | NOMINAL |
| AVE | AVENUE | NTS | NOT TO SCALE |
| BL OR B/L | BASELINE | OC | ON CENTER |
| BLVD | BOULEVARD | P OR PROP | PROPOSED |
| CI | CAST IRON | PE | PLAIN END |
| CEN | CENTER | PGL | PROFILE GRADE LINE |
| CL OR C/L | CENTERLINE | PL OR P/L | PROPERTY LINE |
| CLR | CLEAR | PVC | POLYVINYL CHLORIDE |
| CMP | CORRUGATED METAL PIPE | PVMT OR PVT | PAVEMENT |
| CONC | CONCRETE | R OR RAD | RADIUS |
| CONST | CONSTRUCTION | RCP | REINFORCED CONCRETE PIPE |
| CONT | CONTINUOUS | RED | REDUCER |
| DWMD | DENVER WASTEWATER MANAGEMENT DISTRICT | REC | RECEPTION |
| DIA | DIAMETER | REF | REFERENCE |
| DIP | DUCTILE IRON PIPE | REINF | REINFORCING |
| DN | DOWN | REQ | REQUIRED |
| DWG | DRAWING | REV | REVISION |
| EA | EACH | ROW | RIGHT OF WAY |
| ELEV OR EL | ELEVATION | RT | RIGHT |
| ELB | ELBOW | SCH | SCHEDULE |
| EW | EACH WAY | ST | STORM SEWER |
| EXIST | EXISTING | SE | SIDEWALK EASEMENT |
| FH | FIRE HYDRANT | SQ | SQUARE |
| FIN | FINISHED | ST | STREET |
| FL OR F/L | FLOWLINE | STA | STATION |
| FLG | FLANGE | STD | STANDARD |
| FT | FOOT/FEET | STL | STEEL |
| FRP | FIBERGLASS REINFORCED PIPE | SS | SANITARY SEWER |
| GAL | GALLON | TB | THRUST BLOCK |
| GALV | GALVANIZED | THD | THREADED |
| GAU | GAUGE (MATERIAL) | THICK | THICKNESS |
| GV | GATE VALVE | TOS | TOP OF SEWER |
| GW | GROUNDWATER | TYP | TYPICAL |
| HP | HIGH POINT | UE | UTILITY EASEMENT |
| HORIZ | HORIZONTAL | UG | UNDERGROUND |
| HCL | HORIZONTAL CONTROL LINE | VERT | VERTICAL |
| HR | HOUR | W | WIDTH |
| INV | INVERT | W/ | WITH |
| LBS | POUNDS | WAT | WATER |
| LF | LINEAR FEET | | |
| LT | LEFT | | |
| LP | LOW POINT | | |
| MAX | MAXIMUM | | |
| MFGR | MANUFACTURER | | |
| MH | MANHOLE | | |
| MID | MIDDLE OR MIDPOINT | | |
| MIN | MINIMUM | | |
| MJ | MECHANICAL JOINT | | |
| MSL | MEAN SEA LEVEL | | |

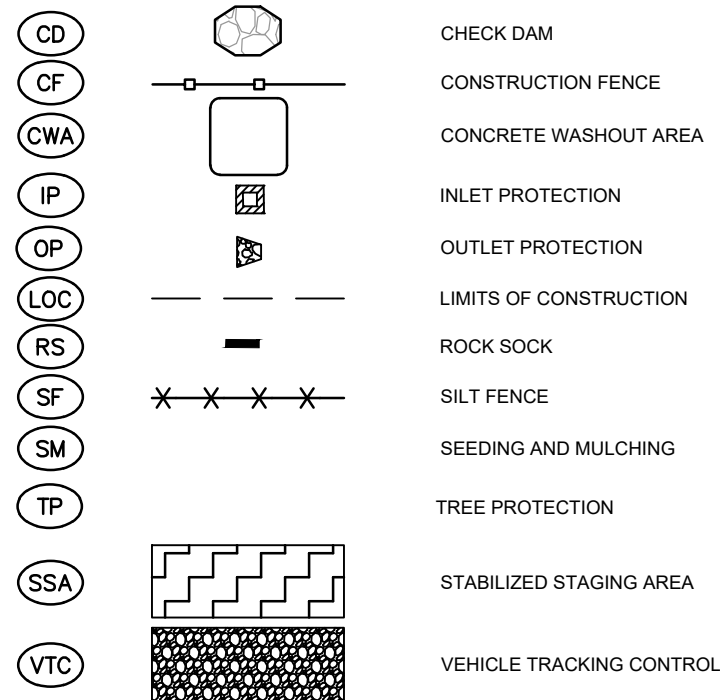

| ITEM NUMBER | DESCRIPTION | UNIT | INITIAL | INTERIM | TOTAL |
|-------------|------------------------------|------|---------|---------|-------|
| 208-00013 | EROSION CONTROL LOG (TYPE I) | LF | 6 | | 6 |
| 208-00035 | AGGREGATE BAG | LF | 140 | 100 | 240 |
| 208-00045 | CONCRETE WASHOUT STRUCTURE | EA | 2 | | 2 |
| 208-00053 | INLET PROTECTION (TYPE I) | EA | 8 | 6 | 14 |
| 208-00054 | INLET PROTECTION (TYPE II) | EA | 2 | | 2 |
| 208-00070 | VEHICLE TRACKING PAD | EA | 2 | | 2 |
| 212-00101 | TREE PROTECTION | EA | 9 | | 9 |
| 212-00005 | SEEDING (NATIVE) | ACRE | | 0.05 | 0.05 |
| 213-00000 | MULCHING | ACRE | | 0.05 | 0.05 |
| 208-00020 | SILT FENCE | LF | 800 | | 800 |

*EROSION CONTROL TO BE MEASURED AND PAID FOR BY THE LUMP SUM ITEM EROSION CONTROL

C:\wip\10056249\Connecting_Auraria_SWMP_Cover.dwg

Print Date: 5/18/2022
 File Name: Connecting_Auraria_SWMP_Cover.dwg
 Horiz. Scale: Vert. Scale: As Noted

990 S Broadway, Suite 220
 Denver, CO 80209
 (303) 297-2976 main
 (303) 297-2693 fax
 www.wilsonco.com

| Sheet Revisions | | |
|-----------------|-------------|-------|
| Date: | Comments | Init. |
| 6/28/2022 | ADDENDUM #1 | BDB |
| | | |
| | | |

DEPARTMENT OF TRANSPORTATION & INFRASTRUCTURE
 201 WEST COLFAX AVENUE
 DENVER, CO 80202
 PHONE: (720) 913-4501
 FAX: (720) 913-4544

| | | | |
|----------------|----------------------------------|-------------------------|------------------|
| As Constructed | STORMWATER MANAGEMENT NOTE SHEET | | Project No./Code |
| No Revisions: | Designer: BDB | Structure Numbers | |
| Revised: | Detailer: LML | | |
| Void: | Sheet Subset: EC | Subset Sheets: 02 of 11 | Sheet Number 181 |

CDOT REVISION SECTION 208: CONSTRUCTION MAT MATERIAL & INSTALLATION REQUIREMENTS

Sample Project Special: 208cm
02-13-2019

1
REVISION OF SECTION 208
CONSTRUCTION MATS

Section 208 of the Standard Specifications is hereby revised for this project to include the following:

DESCRIPTION

208.13 This work consists of furnishing and installing construction mats to support equipment working in wetlands, streams, and other locations designated on the plans while protecting the soils and vegetation beneath from damage.

MATERIALS

208.14 Construction mats shall be capable of supporting the anticipated loads on the types of soil that will be encountered. Larger mats shall be used on soils with low bearing strength (e.g., muck or peat) to spread the weight over a larger area. Construction mats shall be free of leachable preservatives or other constituents harmful to aquatic environments. All treated wood shall contain a quality mark or letter of certification from a third party inspection agency assuring the product meets the minimum American Wood Protection Association (AWPA) Use Category 4A standard. The Contractor may fabricate the mats or use prefabricated mats designed for these purposes.

(a) *Construction Mats Fabricated by the Contractor.* The construction mats shall be fabricated of wooden cants, sawn dense hardwoods, or round logs fastened together. The mats shall be fabricated of cants or logs of length, width, and thickness to meet anticipated loads, soil strength, and construction equipment sizes. Alternative materials may be used if approved by the Engineer.

The mats shall be capable of being connected using quick links or other heavy-duty connectors if needed for stability or to reduce movement.

The Contractor's mat design shall be submitted to the Engineer for review and approval at least three weeks before the mats are to be used on the project. The design shall include a list of equipment and materials to be placed on the mats and anticipated loading.

Mats that are determined to be inadequate to support the required loads or protect the soil and vegetation beneath shall be removed from the project and replaced with adequate mats at the Contractor's expense.

(a) *Prefabricated Construction Mats.* Pre-fabricated mats shall be made of natural timber or other material approved by CDOT's Project Engineer. Mats shall be capable of assembly to form appropriate size mats to be placed directly onto ground surfaces for the purposes of holding or transferring heavy equipment, preventing excessive rutting, and minimizing vegetation disturbance.

(b) *Hardware.* Construction mats shall be supplied with all necessary hardware, including all bolts with nuts and washers, timber connectors, drift pins, dowels, nails, screws, spikes, metal pile protectors, steel anchor plates and all other metal fastenings.

CONSTRUCTION REQUIREMENTS

208.15 General. Prior to placement of mats, woody vegetation (willows, shrubs, trees, etc.) shall be cut or trimmed at or slightly above ground level. Vegetation shall not be uprooted, and the root mat of any vegetation shall not be disturbed.

Crossing sites shall be located where stream channel is narrow for the shortest possible clear span and where stream banks are stable and well defined. When feasible on large wetland complexes, structures shall be accessed from opposite sides to avoid crossing the entire wetland.

208.16 Installation. Mats shall be in good condition to ensure proper installation, use, and removal. Mats shall be inspected by the Engineer to ensure they are clean of soil and any invasive plant species seed stock or plant material from previous use. The spread of aquatic nuisance species, including the New Zealand mud snail, shall

Sample Project Special: 208cm
02-13-2019

2
REVISION OF SECTION 208
CONSTRUCTION MATS

be prevented. Specifically, if heavy equipment (including mats) is used that was previously working in another stream, river, lake, pond, or wetland, it shall be cleaned using one of the following procedures:

(1) Remove all mud and debris from equipment (tracks, turrets, buckets, drags, teeth, etc.) and spray/soak equipment with a solution of commercial grade quaternary ammonium disinfectant compound containing at least 8.0% active ingredient diluted in solution to achieve at least 0.8% concentration (roughly 12 ounces of product per gallon of water). Treated equipment shall be kept moist for at least 10 minutes, managing rinsate as a solid waste in accordance with local, county, state, or federal regulations, OR

(2) Remove all mud and debris from equipment (tracks, turrets, buckets, drags, teeth, etc.) and spray or soak equipment with water hotter than 140 °F for at least 10 minutes.

Hand tools, boots, and any other equipment that will be used in the water shall be cleaned using option (1) or (2) as well. The equipment shall be dried before use. Equipment shall not be moved from one water body to another without cleaning.

Equipment and associated materials (including mats) shall not be stored, maintained, fueled or repaired in waters of the U.S. or wetlands.

Operating heavy equipment on mats in wetlands shall be minimized.

Impacts to waters of the U.S. or wetlands areas shall be minimized during installation, use, and removal of construction mats. Mats shall be placed in a location that would minimize the amount needed for crossing the waters of the U.S. or wetlands.

Construction mats shall not be dragged into position. More than one layer of mats may be necessary in areas which are inundated or have deep organic wetland soils.

At crossings where no flow is present or anticipated during project construction, the mats may be placed directly onto the ground in order to prevent excessive rutting, provided stream banks and bottoms are not adversely altered.

For further protection, mats may be installed on top of nonwoven geotextile that covers the crossing area.

Construction mats may be used as a temporary bridge over a stream to allow vehicles access to the work site. Mats shall not be placed so that they restrict the natural flow of the stream. When used for flowing water crossings, small sections of mat shall be placed within and along the stream parallel to the flow of water. Mats shall then be placed perpendicular to the stream, resting on top of the initial construction mat supports. It may be necessary to place additional reinforcement for extra stability and to minimize the amount of sediment that could fall between the spaces of each timber.

In most cases, construction mats shall be placed along the travel area so that the individual cants or logs are resting perpendicular to the direction of traffic. Mats shall be placed far enough on either side of the stream or wetland to rest on firm ground.

Adequate erosion and sediment controls shall be installed at approaches to mats to promote a smooth transition to, and minimize sediment tracking onto, construction mats.

Matted crossings of waters of the U.S. or wetlands shall be monitored to assure correct functioning of the mats. Mats shall be inspected during use for any defects or structural problems. Mats which become covered with soils or construction debris shall be cleaned and the materials removed and disposed of in an upland location. The material shall not be scraped and shoveled into the resource area. Mats which become imbedded shall be reset or layered to prevent mud from covering them or water passing over them.

Sample Project Special: 208cm
02-13-2019

3
REVISION OF SECTION 208
CONSTRUCTION MATS

208.17 Removal Mats shall be removed by "backing" out of the site, removing mats one at a time. Construction mats shall not be dragged out of position. All other material placed for protection, such as geotextile fabric, straw, etc. shall then be removed. Any rutting or significant indentations identified during mat removal shall be regraded immediately, taking care not to compact soils.

Crossings shall be inspected following mat removal to determine the level of restoration required.

Mats shall be cleaned in an upland area which doesn't drain directly to waters of the U.S. or wetlands before transport to another wetland or stream location. Cleaning methods may include but are not limited to shaking or dropping mats in a controlled manner with a piece of machinery to knock off attached soil and debris, spraying with water or air, and sweeping.

208.18 Restoration. Upon removal of the construction mats, the Contractor and the Engineer shall examine the matted area together to determine what restoration, if any, is required. Restoration shall include, but is not limited to, the following:

Areas of disturbed soil located near waters of the U.S. or wetlands shall be promptly stabilized. Matted areas within wetlands shall be restored to their original condition and elevation. This may involve natural revegetation from existing root and seed stock of native plant species. Conditions may warrant planting and the broadcast of a wetland seed mix over the matted area to supplement the existing seed and rootstock. Seed mixes and vegetation shall contain only native plant species of the appropriate moisture tolerance regime. The use of mulch in wetlands shall consist of weed free mulch to mitigate the risk of the spread of invasive plant species.



METHOD OF MEASUREMENT

208.19 Construction mats will be measured by the square foot. The area to be measured will be the maximum total area of construction mats in place at any one time.

BASIS OF PAYMENT

208.20 Construction mat and any associated items such as geotextile, hay, straw or embankment will not be measured and paid for separately but shall be included in the lump sum item Water Control.

C:\p\p\10056249\Connecting_Auraria_SWMP_Cover.dwg

| | | | | | | | | | | |
|---|--|-----------------|-------------|-------|--|----------------|---------------------------------------|-----------|-------------------------|------------------|
| Print Date: 5/18/2022 | | Sheet Revisions | | |  <p>DEPARTMENT OF TRANSPORTATION & INFRASTRUCTURE 201 WEST COLFAX AVENUE DENVER, CO 80202 PHONE: (720) 913-4501 FAX: (720) 913-4544</p> | As Constructed | STORMWATER MANAGEMENT DETAIL SHEET | | | Project No./Code |
| File Name: Connecting_Auraria_SWMP_Cover.dwg | | Date: | Comments | Init. | | | No Revisions: | Designer: | BDB | Structure |
| Horiz. Scale: Vert. Scale: As Noted | | 6/28/2022 | ADDENDUM #1 | BDB | | Revised: | Detailer: | LML | Numbers | |
|  <p>990 S Broadway, Suite 220 Denver, CO 80209 (303) 297-2976 main (303) 297-2693 fax www.wilsonco.com</p> | | | | | | Void: | Sheet Subset: | EC | Subset Sheets: 11 of 11 | Sheet Number 190 |

CONNECTING AURARIA - ADDENDUM #1

ATTACHMENT 3 - As-built Drawings

Larimer St. Bridge

Table of Contents

| | |
|------------------------|---|
| Title Sheet | 2 |
| General Plan & Summary | 3 |
| Abutments | 4 |
| Pier | 5 |
| Girders | 6 |
| Deck | 7 |

CITY AND COUNTY OF DENVER
 DEPARTMENT OF PUBLIC WORKS
 ENGINEERING SECTION

LARIMER ST. BRIDGE
 OVER
 CHERRY CREEK
 BOND PROJECT NO. 2-4

| INDEX OF SHEETS | | |
|-----------------|---|---------|
| Sheet No. | Description | Dwg No. |
| 1 | Title Sheet | 131-5 |
| 2 | General Plan & Summary | " |
| 3 | Abutments | " |
| 4 | Pier | " |
| 5 | Girders | " |
| 6 | Deck | " |
| | Standard Bridge Rolling, Curb & Drainage Details | 134-20A |
| | Standard Signs | 104-1B |
| | Standard Details for Street Paving | 104-1C |
| | Standard Details for Barricades | 104-1E |
| | Standard Sidewalk & Driveway Details in Commercial Areas | 104-1V |
| | No. 13 Inlet for 6" Vertical Curb, etc. | 114-2 |

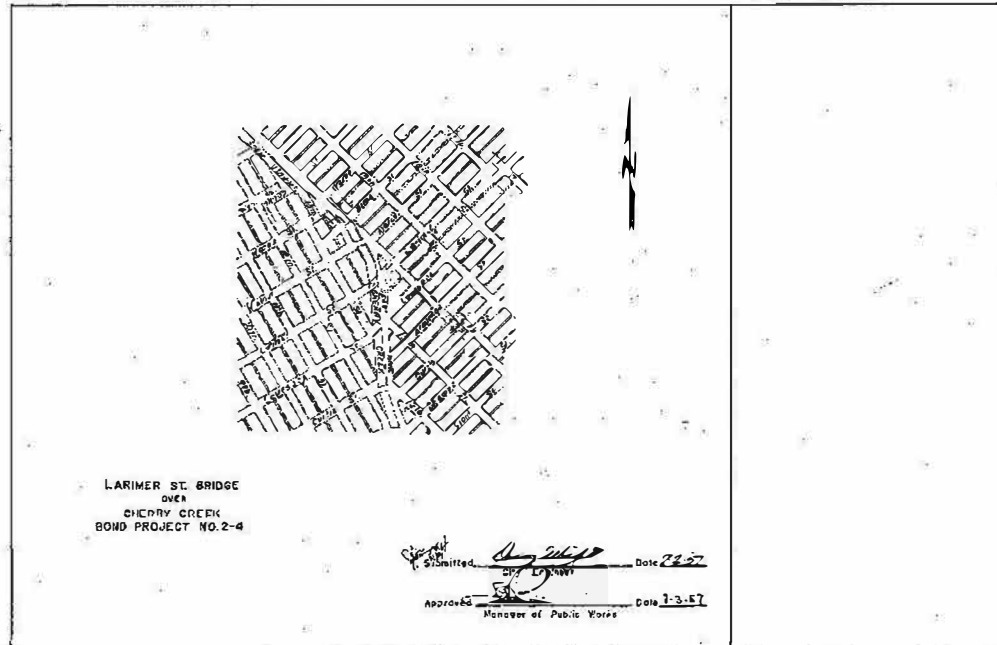

Recommended & Collected By: H. Keshen Date 7-5-57
 Structural Mason Engineer

Recommended: [Signature] Date 7-3-57
 Design Engineer

Recommended: [Signature] Date 7-2-57
 Deputy City Engineer

Approved: [Signature] Date 7-2-57
 City Engineer

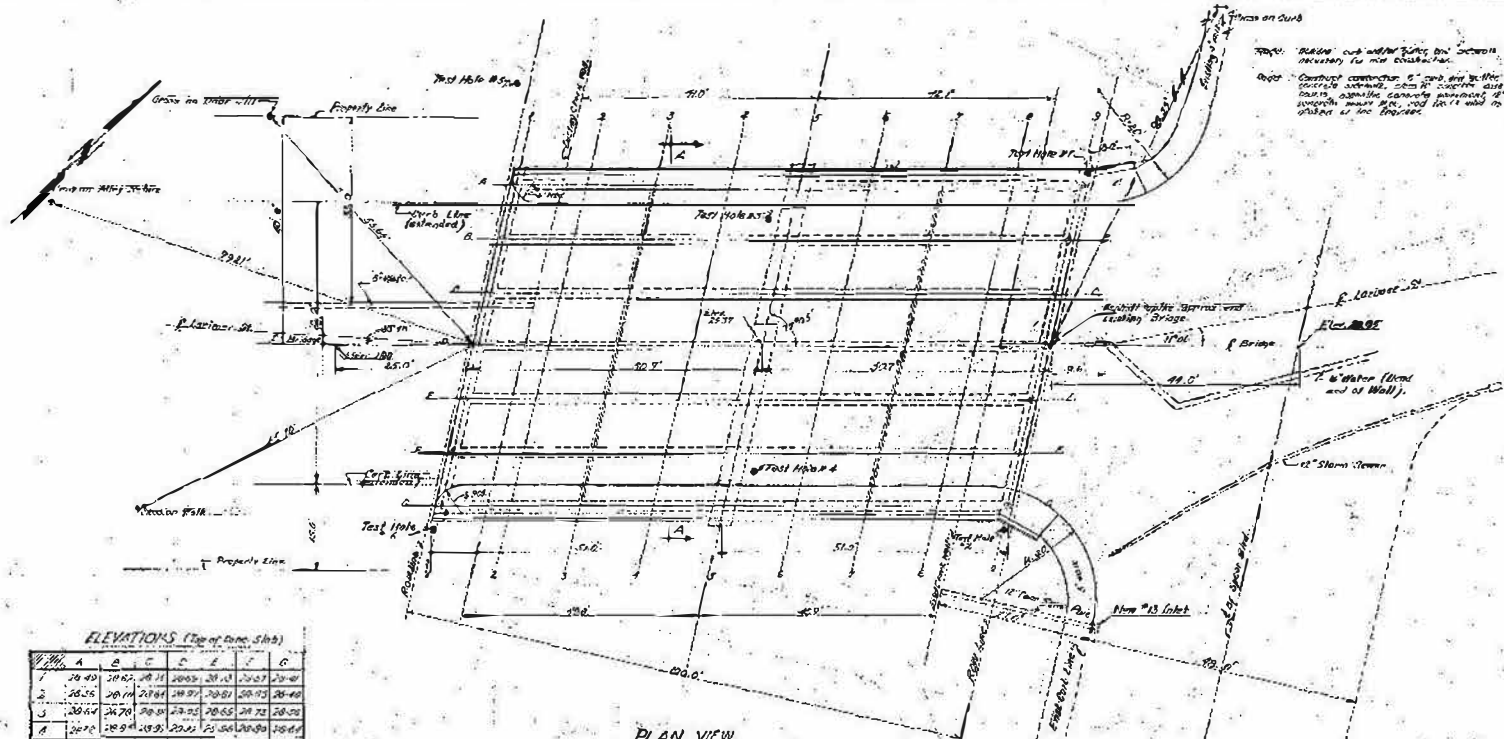

ELEVATIONS (Top of Lane Slabs)

| Station | A | B | C | D | E | F | G |
|---------|-------|-------|-------|-------|-------|-------|-------|
| 1 | 26.40 | 26.62 | 26.71 | 26.65 | 26.41 | 26.27 | 26.20 |
| 2 | 26.25 | 26.44 | 26.64 | 26.67 | 26.67 | 26.72 | 26.46 |
| 3 | 26.64 | 26.70 | 26.80 | 26.92 | 26.65 | 26.72 | 26.52 |
| 4 | 26.76 | 26.94 | 26.93 | 26.91 | 26.54 | 26.47 | 26.47 |
| 5 | 26.00 | 26.03 | 26.01 | 26.03 | 26.07 | 26.01 | 26.02 |
| 6 | 26.04 | 26.07 | 26.05 | 26.26 | 26.42 | 26.21 | 26.00 |
| 7 | 26.57 | 26.53 | 26.21 | 26.56 | 26.20 | 26.44 | 26.07 |
| 8 | 26.02 | 26.46 | 26.36 | 26.34 | 26.17 | 26.11 | 26.01 |
| 9 | 26.21 | 26.24 | 26.30 | 26.51 | 26.35 | 26.19 | 26.03 |

PLAN VIEW
 All elevations shown above are to top of Abutment, Pier and Lane Slab Floor.

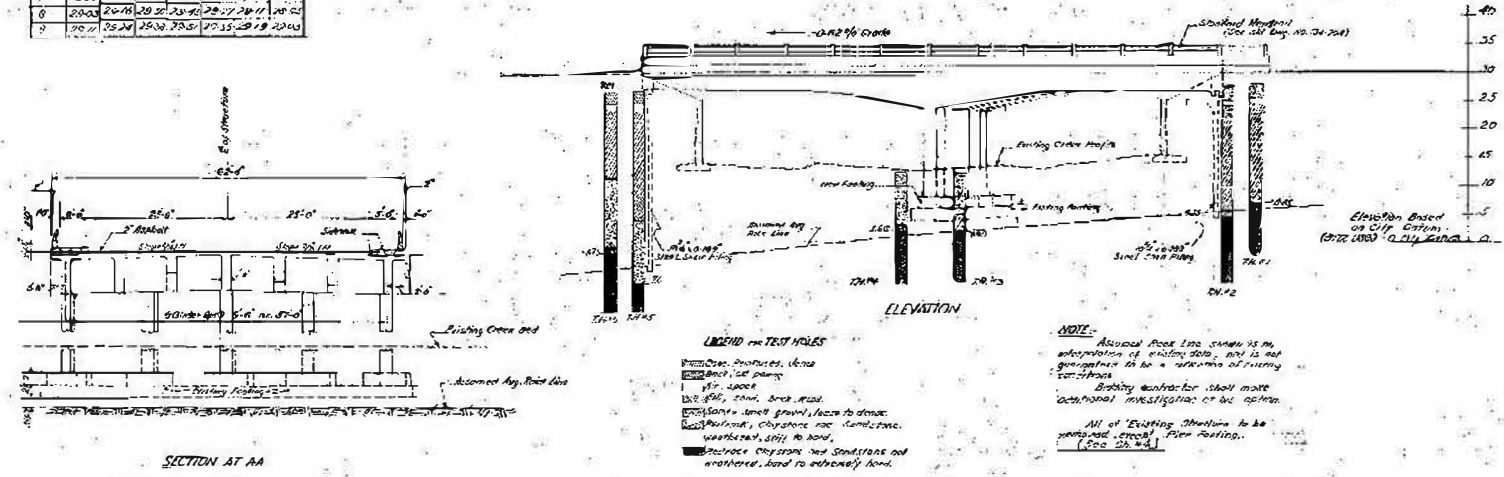

LEGEND FOR TEST HOLES

- Concrete Structures, Ultra
- Reinforcing Steel
- Steel Deck
- Steel Deck, Steel Deck
- Concrete Wall, Foundation to be done
- Reinforcing, Claystone, etc. (see notes)
- Weathered, Still to do
- Reinforcing Claystone and Sandstone and otherwise, hard to extremely hard.

NOTE:
 Actual Road Line shown is no indication of existing data, nor is not guaranteed to be a reference of existing conditions.
 Existing contractor shall make additional investigation as he deems.
 All of Existing Structure to be removed, except Pier Footings.
 (See 26.44)

GENERAL NOTES

All work shall be done in accordance with Specifications of the City Engineer, City and County of Denver, and all applicable standards and codes.
SPECIFICATIONS
 Standard Specifications for Highway Bridges by the American Association of State Highway Officials, 1953 Edition, with amendments.
 Concrete: 2800 psi (compressive strength) Reinforcing Steel: 70,000 psi
LOADING
 Live Load: AASHTO HS-20-44 Loading
 Wind: 50 psi on 10' high flat area of Structure with a duration of 300 psi
TEMPERATURE
 Normal Temperature occurs at 64°F
 Temperature rise 32°F
 Temperature fall 45°F

SUMMARY OF QUANTITIES

| Item No. | Description | Quantity |
|----------------------------|--------------------------------|-------------|
| BRIDGE | | |
| 2a | Reinforcing Existing Bridge | 2000 Sds |
| 6 | Structural Excavation | 170 Cu Yds |
| 14a | Class "C" Concrete | 570 Cu Yds |
| 12a | Reinforcing Steel | 34,000 Lbs |
| 15a | Aluminum Handrail | 276 Lb. Ft. |
| 27 | 10% Class "B" Filling | 350 Cu Yds |
| APPROACHES / PAVING | | |
| 2c | Reinforcing Subgrade | 90 Cu Ft. |
| | Reinforcing Subgrade | 150 Cu Ft. |
| 12c | Construction of Curb / Gutters | 120 Cu Ft. |
| 12c | Concrete Sidewalk | 220 Cu Ft. |
| 12c | Class "C" Concrete Base Course | 23 Cu Yds |
| 21a | Form Coat | 400 Sq. Ft. |
| 20b | Asphaltic Concrete | 100 Tons |
| 23.5 | 12" Concrete Roman Pipe | 28 Lm. Ft. |
| 24 | #12 Inlet for 6" Curb | 1 Ea. |

REVISED

| Date | By | Description |
|------|----|-------------|
| | | |
| | | |

CITY AND COUNTY OF DENVER
 DEPARTMENT OF PUBLIC WORKS
 ENGINEERING SECTION

BOND PROJECT NO. 2-4
 LARIMER ST. BRIDGE
 over CHERRY CREEK

GENERAL PLAN & SUMMARY

DATE: 10-26-57
 DRAWN BY: J.L.S.
 CHECKED BY: J.L.S.
 OFFICE NO. 2
 SHEET 13 OF 15

REINFORCING STEEL SCHEDULE
(See One Abutment)

| Mark | Size | No. | Length | Weight | Height | Type |
|------|------|-----|--------|--------|--------|----------------------|
| A1 | #7 | 2 | 55'1" | 140 | 2048 | SM |
| A2 | #7 | 4 | 30'3" | 127 | 2044 | SM |
| A3 | #4 | 34 | 10'0" | 368 | 2582 | L |
| A4 | #4 | 4 | 32'0" | 128 | 1692 | BS For |
| | | | | | | 975 Total |
| | | | | | | Abutments 1750 Total |

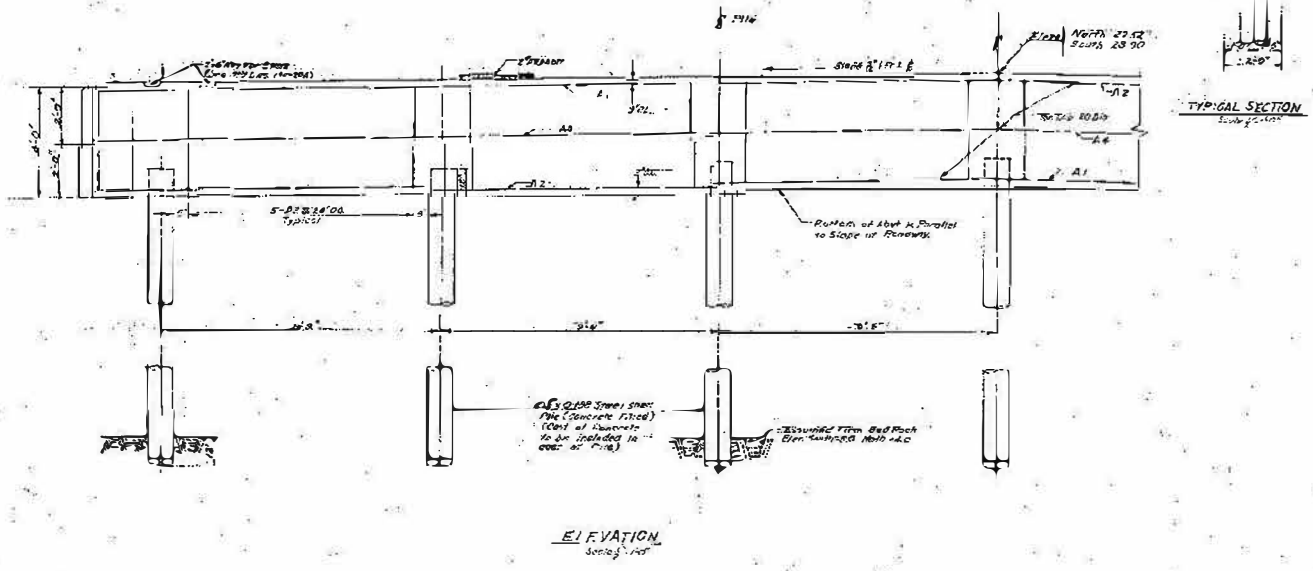
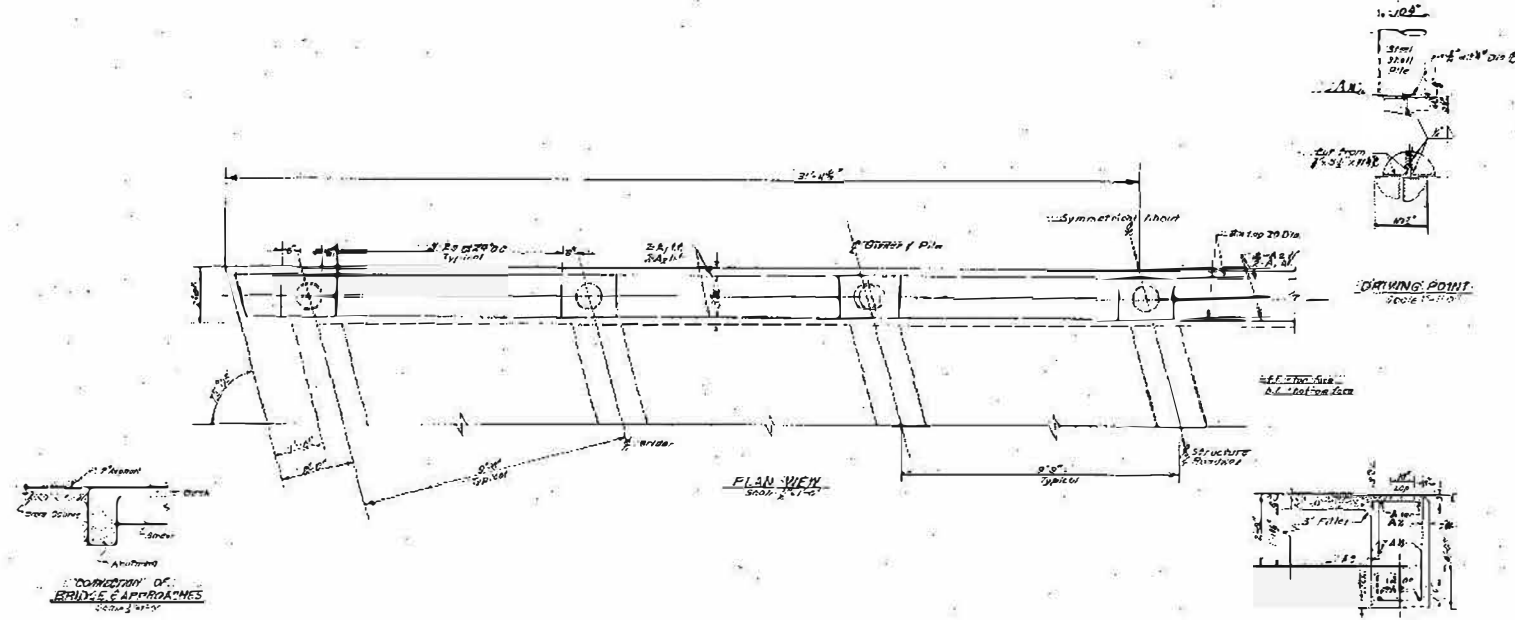

REVISIONS

| NO. | DATE | DESCRIPTION |
|-----|------|-------------|
| | | |

CITY AND COUNTY OF DENVER
 DEPARTMENT OF PUBLIC WORKS
 ENGINEERING SECTION

BOND PROJECT NO. 2-4
 LARIMER ST. BRIDGE
 over CHERRY CREEK
ABUTMENTS

DATE: 10/24/51
 DRAWN BY: J.E. HOFFER
 CHECKED BY: J.E. HOFFER
 DESIGNED BY: J.E. HOFFER
 APPROVED BY: J.E. HOFFER

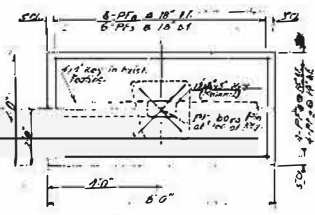
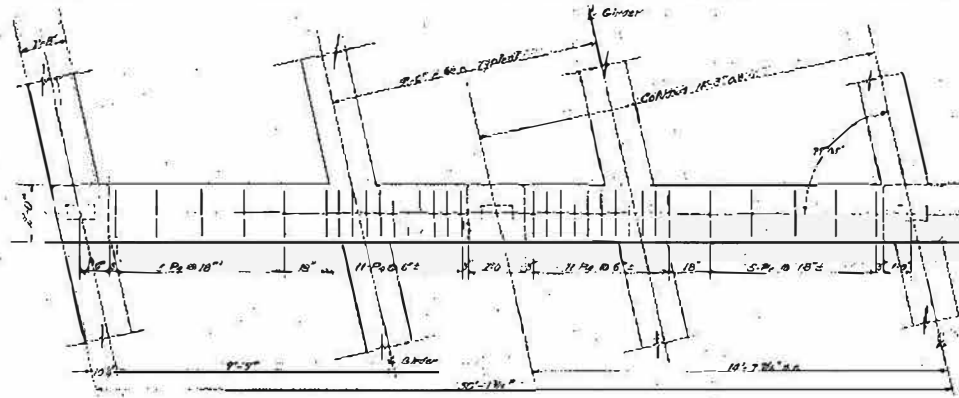

FOOTING PLAN
Scale: 3/4" = 1'-0"

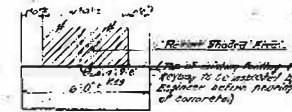

ELEVATION - EXIST. FOOTING
Scale: 3/4" = 1'-0"

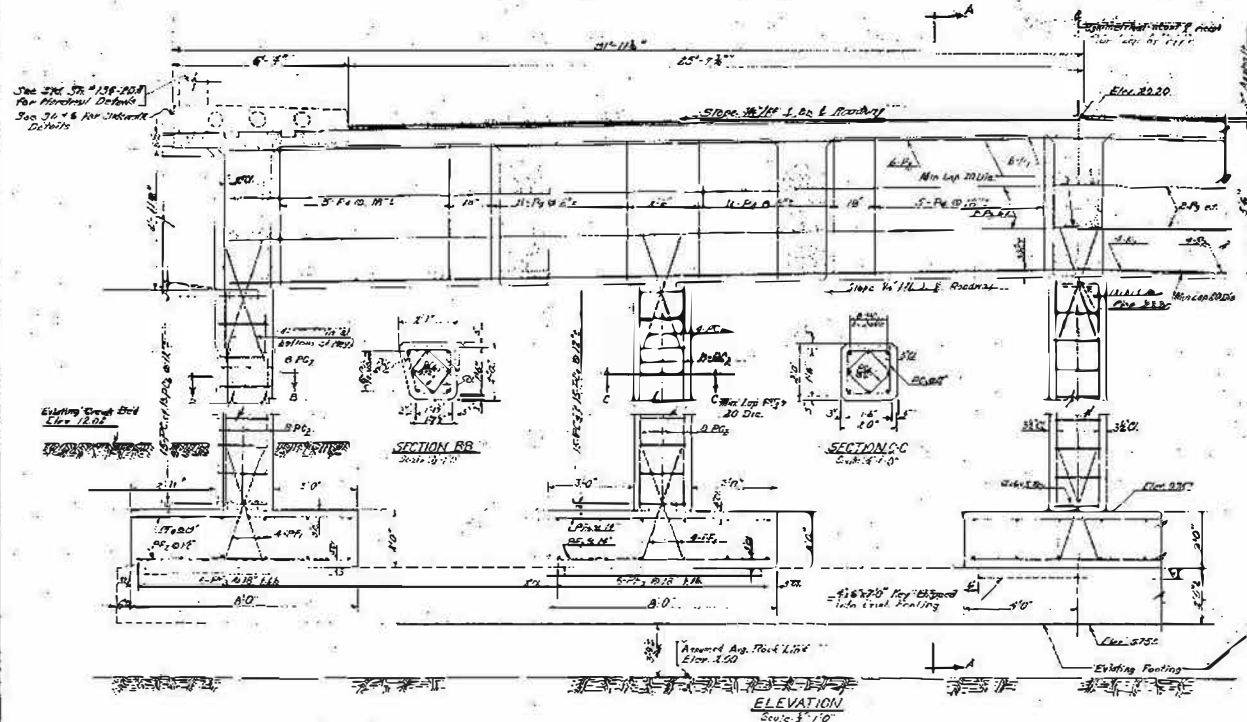

| REINFORCING STEEL SCHEDULE | | | | | | | | | | |
|----------------------------|----------|-----|--------|------|--------------|--------|----------|---|---|---|
| Item No. | Bar Size | No. | Length | Unit | Total Weight | Spec. | A | B | C | D |
| 1 | #10 | 10 | 34.9 | 549 | 4,532.1 | 549 | | | | |
| 2 | #10 | 10 | 27.5 | 258 | 4,500.1 | 258 | | | | |
| 3 | #8 | 8 | 50.6 | 364 | 2,448.1 | 364 | | | | |
| 4 | #8 | 8 | 56.6 | 464 | 2,668.1 | 464 | | | | |
| | | | | | | 38.16" | Pier Cap | | | |
| 5 | #10 | 10 | 1.3 | 85 | 1,365 | 360 | | | | |
| 6 | #10 | 10 | 0.4 | 480 | 4,800 | 2,112 | | | | |
| 7 | #8 | 8 | 1.5 | 288 | 2,058 | 176 | | | | |
| 8 | #8 | 8 | 4.9 | 274 | 2,448 | 183 | | | | |
| 9 | #8 | 8 | 4.7 | 271 | 2,409 | 176 | | | | |
| 10 | #8 | 8 | 4.7 | 271 | 2,409 | 176 | | | | |
| | | | | | | 32.55" | Columns | | | |
| 11 | #10 | 20 | 7.3 | 85 | 1,365 | 360 | | | | |
| 12 | #10 | 20 | 7.6 | 150 | 2,070 | 367 | | | | |
| 13 | #8 | 60 | 3.6 | 270 | 2,409 | 183 | | | | |
| 14 | #8 | 20 | 7.3 | 150 | 2,070 | 360 | | | | |
| | | | | | | 213 | Footings | | | |
| TOTAL | | | | | | | | | | |

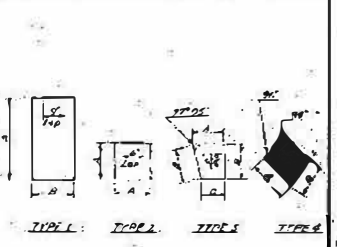

TOTAL REINFORCING STEEL 3,364 LB.
TOTAL CLASS "A" CONCRETE 45 cu. yd.

REVISED
Date: _____ By: _____

CITY AND COUNTY OF DENVER
DEPARTMENT OF PUBLIC WORKS
ENGINEERING SECTION

ROAD PROJECT NO. 4
LARIMER ST. BRIDGE
over CHERRY CREEK
PIER

DATE: _____ DRAWN BY: _____ CHECKED BY: _____

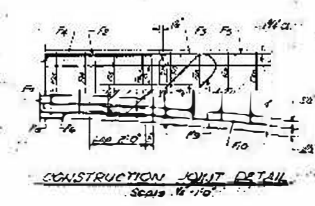
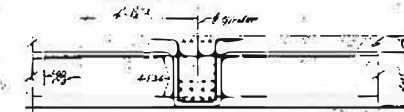
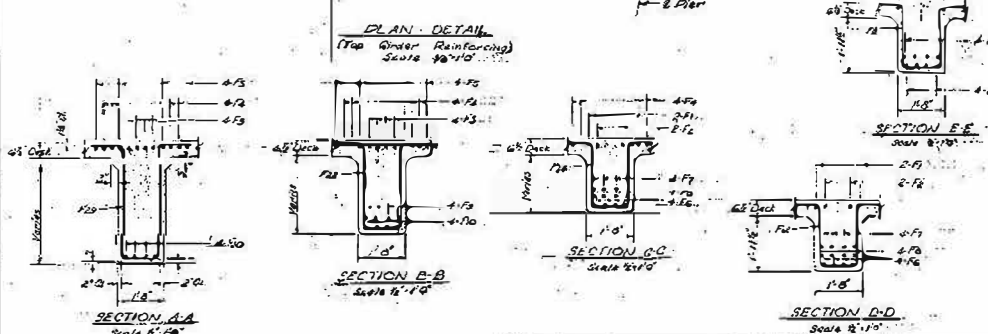
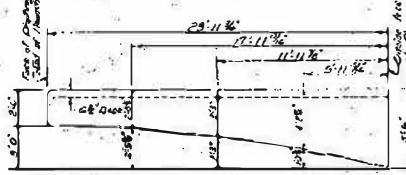
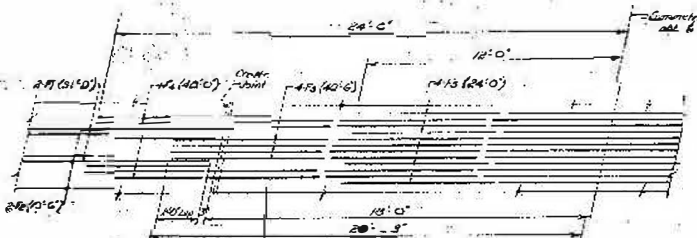
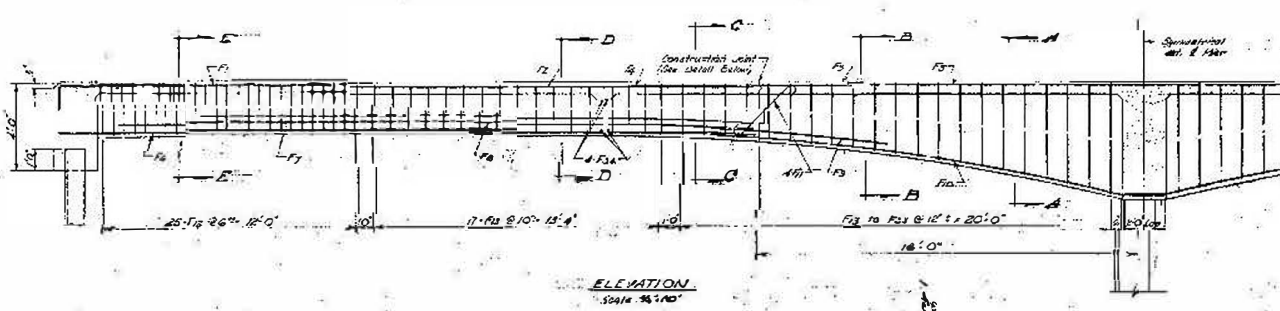
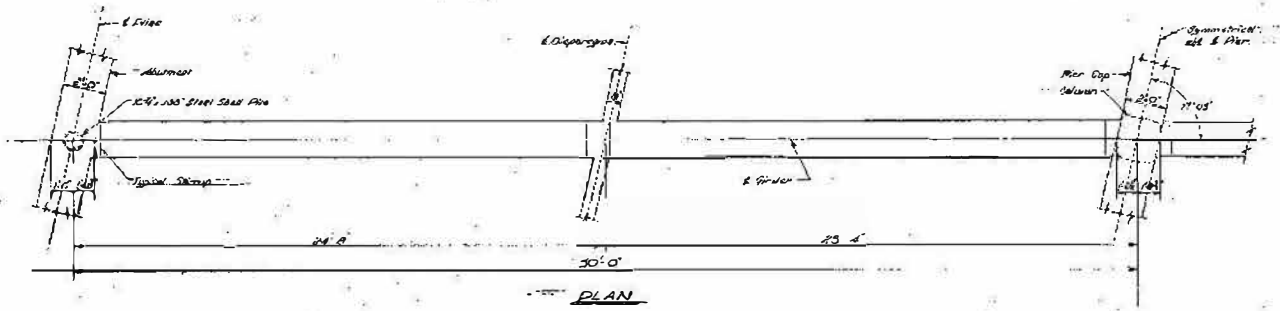

REINFORCING STEEL SCHEDULE

| Bar | Size | No. | Length | Total Length | Weight | Vol. Conc. | Area | Area | Area |
|-----------------------------------|------|-----|---------|--------------|--------|------------|------|------|-----------|
| F1 | #10 | 4 | 30'-0" | 120'-0" | 131' | 230 | 50.4 | 1 | 3'5" 1/2" |
| F2 | #10 | 4 | 100'-0" | 400'-0" | 47' | 101 | 209 | | |
| F3 | #10 | 4 | 100'-0" | 400'-0" | 46' | 97 | 194 | | |
| F4 | #10 | 4 | 100'-0" | 400'-0" | 46' | 97 | 194 | | |
| F5 | #10 | 4 | 100'-0" | 400'-0" | 46' | 97 | 194 | | |
| F6 | #10 | 4 | 100'-0" | 400'-0" | 46' | 97 | 194 | | |
| F7 | #10 | 4 | 100'-0" | 400'-0" | 46' | 97 | 194 | | |
| F8 | #10 | 4 | 100'-0" | 400'-0" | 46' | 97 | 194 | | |
| F9 | #10 | 4 | 100'-0" | 400'-0" | 46' | 97 | 194 | | |
| F10 | #10 | 4 | 100'-0" | 400'-0" | 46' | 97 | 194 | | |
| F11 | #10 | 4 | 100'-0" | 400'-0" | 46' | 97 | 194 | | |
| F12 | #10 | 4 | 100'-0" | 400'-0" | 46' | 97 | 194 | | |
| F13 | #10 | 4 | 100'-0" | 400'-0" | 46' | 97 | 194 | | |
| F14 | #10 | 4 | 100'-0" | 400'-0" | 46' | 97 | 194 | | |
| F15 | #10 | 4 | 100'-0" | 400'-0" | 46' | 97 | 194 | | |
| F16 | #10 | 4 | 100'-0" | 400'-0" | 46' | 97 | 194 | | |
| F17 | #10 | 4 | 100'-0" | 400'-0" | 46' | 97 | 194 | | |
| F18 | #10 | 4 | 100'-0" | 400'-0" | 46' | 97 | 194 | | |
| F19 | #10 | 4 | 100'-0" | 400'-0" | 46' | 97 | 194 | | |
| F20 | #10 | 4 | 100'-0" | 400'-0" | 46' | 97 | 194 | | |
| F21 | #10 | 4 | 100'-0" | 400'-0" | 46' | 97 | 194 | | |
| F22 | #10 | 4 | 100'-0" | 400'-0" | 46' | 97 | 194 | | |
| F23 | #10 | 4 | 100'-0" | 400'-0" | 46' | 97 | 194 | | |
| F24 | #10 | 4 | 100'-0" | 400'-0" | 46' | 97 | 194 | | |
| F25 | #10 | 4 | 100'-0" | 400'-0" | 46' | 97 | 194 | | |
| F26 | #10 | 4 | 100'-0" | 400'-0" | 46' | 97 | 194 | | |
| F27 | #10 | 4 | 100'-0" | 400'-0" | 46' | 97 | 194 | | |
| F28 | #10 | 4 | 100'-0" | 400'-0" | 46' | 97 | 194 | | |
| F29 | #10 | 4 | 100'-0" | 400'-0" | 46' | 97 | 194 | | |
| F30 | #10 | 4 | 100'-0" | 400'-0" | 46' | 97 | 194 | | |
| F31 | #10 | 4 | 100'-0" | 400'-0" | 46' | 97 | 194 | | |
| F32 | #10 | 4 | 100'-0" | 400'-0" | 46' | 97 | 194 | | |
| F33 | #10 | 4 | 100'-0" | 400'-0" | 46' | 97 | 194 | | |
| F34 | #10 | 4 | 100'-0" | 400'-0" | 46' | 97 | 194 | | |
| F35 | #10 | 4 | 100'-0" | 400'-0" | 46' | 97 | 194 | | |
| F36 | #10 | 4 | 100'-0" | 400'-0" | 46' | 97 | 194 | | |
| F37 | #10 | 4 | 100'-0" | 400'-0" | 46' | 97 | 194 | | |
| F38 | #10 | 4 | 100'-0" | 400'-0" | 46' | 97 | 194 | | |
| F39 | #10 | 4 | 100'-0" | 400'-0" | 46' | 97 | 194 | | |
| F40 | #10 | 4 | 100'-0" | 400'-0" | 46' | 97 | 194 | | |
| F41 | #10 | 4 | 100'-0" | 400'-0" | 46' | 97 | 194 | | |
| F42 | #10 | 4 | 100'-0" | 400'-0" | 46' | 97 | 194 | | |
| F43 | #10 | 4 | 100'-0" | 400'-0" | 46' | 97 | 194 | | |
| F44 | #10 | 4 | 100'-0" | 400'-0" | 46' | 97 | 194 | | |
| F45 | #10 | 4 | 100'-0" | 400'-0" | 46' | 97 | 194 | | |
| F46 | #10 | 4 | 100'-0" | 400'-0" | 46' | 97 | 194 | | |
| F47 | #10 | 4 | 100'-0" | 400'-0" | 46' | 97 | 194 | | |
| F48 | #10 | 4 | 100'-0" | 400'-0" | 46' | 97 | 194 | | |
| F49 | #10 | 4 | 100'-0" | 400'-0" | 46' | 97 | 194 | | |
| F50 | #10 | 4 | 100'-0" | 400'-0" | 46' | 97 | 194 | | |
| F51 | #10 | 4 | 100'-0" | 400'-0" | 46' | 97 | 194 | | |
| F52 | #10 | 4 | 100'-0" | 400'-0" | 46' | 97 | 194 | | |
| F53 | #10 | 4 | 100'-0" | 400'-0" | 46' | 97 | 194 | | |
| F54 | #10 | 4 | 100'-0" | 400'-0" | 46' | 97 | 194 | | |
| F55 | #10 | 4 | 100'-0" | 400'-0" | 46' | 97 | 194 | | |
| F56 | #10 | 4 | 100'-0" | 400'-0" | 46' | 97 | 194 | | |
| F57 | #10 | 4 | 100'-0" | 400'-0" | 46' | 97 | 194 | | |
| F58 | #10 | 4 | 100'-0" | 400'-0" | 46' | 97 | 194 | | |
| F59 | #10 | 4 | 100'-0" | 400'-0" | 46' | 97 | 194 | | |
| F60 | #10 | 4 | 100'-0" | 400'-0" | 46' | 97 | 194 | | |
| F61 | #10 | 4 | 100'-0" | 400'-0" | 46' | 97 | 194 | | |
| F62 | #10 | 4 | 100'-0" | 400'-0" | 46' | 97 | 194 | | |
| F63 | #10 | 4 | 100'-0" | 400'-0" | 46' | 97 | 194 | | |
| F64 | #10 | 4 | 100'-0" | 400'-0" | 46' | 97 | 194 | | |
| F65 | #10 | 4 | 100'-0" | 400'-0" | 46' | 97 | 194 | | |
| F66 | #10 | 4 | 100'-0" | 400'-0" | 46' | 97 | 194 | | |
| F67 | #10 | 4 | 100'-0" | 400'-0" | 46' | 97 | 194 | | |
| F68 | #10 | 4 | 100'-0" | 400'-0" | 46' | 97 | 194 | | |
| F69 | #10 | 4 | 100'-0" | 400'-0" | 46' | 97 | 194 | | |
| F70 | #10 | 4 | 100'-0" | 400'-0" | 46' | 97 | 194 | | |
| F71 | #10 | 4 | 100'-0" | 400'-0" | 46' | 97 | 194 | | |
| F72 | #10 | 4 | 100'-0" | 400'-0" | 46' | 97 | 194 | | |
| F73 | #10 | 4 | 100'-0" | 400'-0" | 46' | 97 | 194 | | |
| F74 | #10 | 4 | 100'-0" | 400'-0" | 46' | 97 | 194 | | |
| F75 | #10 | 4 | 100'-0" | 400'-0" | 46' | 97 | 194 | | |
| F76 | #10 | 4 | 100'-0" | 400'-0" | 46' | 97 | 194 | | |
| F77 | #10 | 4 | 100'-0" | 400'-0" | 46' | 97 | 194 | | |
| F78 | #10 | 4 | 100'-0" | 400'-0" | 46' | 97 | 194 | | |
| F79 | #10 | 4 | 100'-0" | 400'-0" | 46' | 97 | 194 | | |
| F80 | #10 | 4 | 100'-0" | 400'-0" | 46' | 97 | 194 | | |
| F81 | #10 | 4 | 100'-0" | 400'-0" | 46' | 97 | 194 | | |
| F82 | #10 | 4 | 100'-0" | 400'-0" | 46' | 97 | 194 | | |
| F83 | #10 | 4 | 100'-0" | 400'-0" | 46' | 97 | 194 | | |
| F84 | #10 | 4 | 100'-0" | 400'-0" | 46' | 97 | 194 | | |
| F85 | #10 | 4 | 100'-0" | 400'-0" | 46' | 97 | 194 | | |
| F86 | #10 | 4 | 100'-0" | 400'-0" | 46' | 97 | 194 | | |
| F87 | #10 | 4 | 100'-0" | 400'-0" | 46' | 97 | 194 | | |
| F88 | #10 | 4 | 100'-0" | 400'-0" | 46' | 97 | 194 | | |
| F89 | #10 | 4 | 100'-0" | 400'-0" | 46' | 97 | 194 | | |
| F90 | #10 | 4 | 100'-0" | 400'-0" | 46' | 97 | 194 | | |
| F91 | #10 | 4 | 100'-0" | 400'-0" | 46' | 97 | 194 | | |
| F92 | #10 | 4 | 100'-0" | 400'-0" | 46' | 97 | 194 | | |
| F93 | #10 | 4 | 100'-0" | 400'-0" | 46' | 97 | 194 | | |
| F94 | #10 | 4 | 100'-0" | 400'-0" | 46' | 97 | 194 | | |
| F95 | #10 | 4 | 100'-0" | 400'-0" | 46' | 97 | 194 | | |
| F96 | #10 | 4 | 100'-0" | 400'-0" | 46' | 97 | 194 | | |
| F97 | #10 | 4 | 100'-0" | 400'-0" | 46' | 97 | 194 | | |
| F98 | #10 | 4 | 100'-0" | 400'-0" | 46' | 97 | 194 | | |
| F99 | #10 | 4 | 100'-0" | 400'-0" | 46' | 97 | 194 | | |
| F100 | #10 | 4 | 100'-0" | 400'-0" | 46' | 97 | 194 | | |
| TOTAL 1701' 7 1/2" = 33, 249 LBS. | | | | | | | | | |

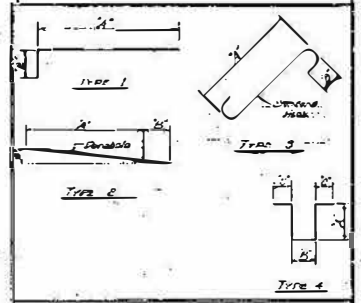

TOTAL REINFORCING STEEL 33,249 LBS.
CLASS A CONCRETE 106 CU YDS.

REVISE

| DATE | BY | NO. | DESCRIPTION |
|------|----|-----|-------------|
| | | | |

CITY AND COUNTY OF DENVER
DEPARTMENT OF PUBLIC WORKS
ENGINEERING SECTION
BOND PROJECT NO. 24
LAWNER ST. BRIDGE
OVER CHERRY CREEK
GIRDERS

CONNECTING AURARIA - ADDENDUM #1
ATTACHMENT 4 - 404 Permit



DEPARTMENT OF THE ARMY
CORPS OF ENGINEERS, OMAHA DISTRICT
DENVER REGULATORY OFFICE
9307 S. WADSWORTH BLVD.
LITTLETON, CO 80128

April 11, 2022

SUBJECT: Nationwide Permit Verification; NWO-2022-00282-DEN, Connecting Auraria - Larimer Street Bridge Replacement, City and County of Denver, Colorado

Deborah Turner
City and County of Denver
Department of Transportation & Infrastructure
201 West Colfax Avenue
Denver, CO 80202

Dear Ms. Turner:

This letter is in response to your February 16, 2022, Pre-construction Notification (PCN), requesting Department of the Army (DA) Nationwide Permit (NWP) verification for the above-referenced project. The project site is located at Latitude 39.74683°, Longitude -105.000569°, within Section 33, Township 3 S, Range 68 W, in Denver County, Colorado.

For the Larimer Street bridge replacement project, you propose to permanently impact 0.01 acre of wetlands and temporarily impact 180 feet of Cherry Creek in order to replacement the Larimer Street bridge.

Project-specific component:

1. Removal of the existing bridge and construction of the new single span bridge with the use of a temporary diversion.

The U.S. Army Corps of Engineers (Corps) regulates the discharge of dredged and fill material into waters of the United States under Section 404 of the Clean Water Act (CWA) (33 U.S.C. 1344). The Corps' regulations are published in the Code of Federal Regulations at 33 CFR parts 320 through 332. NWPs are defined in the Federal Register published on December 27, 2021 (86 FR 73522) and January 13, 2021 (86 FR 2744). Based on a review of the information you furnished and available to us, we have determined the above referenced work requires DA authorization under Section 404 of the CWA.

Based upon the information you provided, we hereby verify that the work described above, which would be performed in accordance with the plans you provided, is

authorized by NWP 14 Linear Transportation Projects. Please note that deviations from the original plans and specifications of your project could require additional authorization from this office. This NWP and associated Regional and General Conditions are enclosed and can be accessed on our website at: <https://www.nwo.usace.army.mil/Missions/Regulatory-Program/Colorado>. Failure to comply with the General and Regional Conditions of this NWP, or the project-specific special conditions of this authorization, may result in the suspension or revocation of your authorization, and you may be subject to appropriate enforcement action. You shall comply with all terms and conditions associated with this NWP, including the following special conditions.

Special Condition:

1. The project will result in no adverse effect to the historic floodwalls (5DV.21.1) with the condition that those walls are not damaged, removed, or relocated during the course of construction. Photographs shall be provided to the State Historic Preservation Officer and this office upon project completion to document the condition of the floodwalls at that time.

Unless this NWP is suspended, modified, or revoked, it is valid until **March 14, 2026**. It is incumbent upon you to remain informed of changes to this NWP. We will issue a public notice when the NWPs are reissued. Furthermore, if you commence or are under contract to commence this activity before the date that the relevant NWP is modified or revoked, you will have twelve (12) months from the date of the modification or revocation of the NWP to complete the activity under the present terms and conditions of this NWP unless discretionary authority has been exercised on a case-by-case basis to modify, suspend, or revoke the authorization as per 33 CFR 330.6(b). Any project specific conditions listed in this letter continue to remain in effect after the NWP verification expires unless the district engineer removes those conditions.

To assist in your compliance with NWP General Condition 30, enclosed is a "Compliance Certification" form, which shall be signed and returned within 30 days of completion of the project, including any required mitigation. Your signature on this form certifies that you have completed the work in accordance with the terms and conditions of the NWP. Activities completed under the authorization of an NWP which was in effect at the time the activity was completed continue to be authorized by that NWP.

Authorizations under this NWP does not relieve permittees from obtaining permits or other authorizations from any required federal, state, or local agency.

-3-

If you have any questions, please contact Celena Cui via email at Celena.H.Cui@usace.army.mil, by mail at the address above, or by phone at (720) 922-3857

Sincerely,

A handwritten signature in black ink, appearing to read 'Kiel Downing', with a stylized flourish at the end.

Kiel Downing
Chief, Denver Regulatory Office

Enclosures

cc: Jon Chesser, Wilson & Company., Inc., Engineers & Architects

The Omaha District, Regulatory Branch is committed to providing quality and timely service to our customers. In an effort to improve customer service, please take a moment to complete our Customer Service Survey found on our website at: <https://regulatory.ops.usace.army.mil/customer-service-survey/>.

COMPLIANCE CERTIFICATION

USACE File Number: NWO-2022-00282-DEN

Permit Type: NWP 14 Linear Transportation Projects

Name of Permittee: Deborah Turner, City and County of Denver

County: Denver County, Colorado

Date of Issuance: April 11, 2022

Project Manager: Celena Cui

Upon completion of the activity authorized by this permit and any mitigation required by the permit, sign this certification and return it to DenverRegulatoryMailbox@usace.army.mil or the following address:

**CORPS OF ENGINEERS, OMAHA DISTRICT
DENVER REGULATORY OFFICE
9307 S. WADSWORTH BLVD.
LITTLETON, CO 80128**

Please note that your permitted activity is subject to a compliance inspection by a U.S. Army Corps of Engineers representative. If you fail to comply with the conditions of this permit, you are subject to permit suspension, modification, or revocation.

I hereby certify that the work authorized by the above referenced permit has been completed in accordance with the terms and conditions of the said permit, and required mitigation was completed in accordance with the permit conditions.

Signature of Permittee

Date

CITY AND COUNTY OF DENVER
STATE OF COLORADO



DENVER
THE MILE HIGH CITY

**DEPARTMENT OF TRANSPORTATION &
INFRASTRUCTURE**

**Updated Pages Only of
Technical Specifications, Plans/Drawings
Complete Copy Filed with Clerk and
Recorder File #20220087**

Contract Number: 202263315

Connecting Auraria

June 6, 2022

**CITY AND COUNTY OF DENVER
DEPARTMENT OF TRANSPORTATION AND INFRASTRUCTURE
CONNECTING AURARIA**

GENERAL CONTRACT CONDITIONS

General Contract Conditions shall be the City and County of Denver, Department of Public Works, “Standard Specifications for Construction General Contract Conditions”, 2011 edition and hereinafter modified shall be used for this project. Supplements or amendments are listed in the Special Contract Conditions.

STANDARD CONSTRUCTION DETAILS

It is the intent of the City to follow City Standard Drawings and details for roadway and traffic signal design. Applicable details from the Colorado Department of Transportation M&S Standards, the City of Denver’s Wastewater Management Division Standard Details, and the Denver Water Department’s Standard Drawings, most recent editions. Drainage related appurtenances shall follow the City and County of Denver (CCD), Department of Public Works document titled “Storm Drainage and Sanitary Sewer Construction Detail and Technical Specifications”. This document can be found at the following web address:
<https://www.denvergov.org/content/denvergov/en/transportation-infrastructure/documents/engineering-plan-review/manuals-regulations.html>

DETAILED CONSTRUCTION SPECIFICATIONS

The Detailed Specifications for this project are defined in the City of Denver Contract Requirements and Contract Documents.

STANDARD CONSTRUCTION SPECIFICATIONS

The 2021 "Colorado Department of Transportation Standard Specifications for Road and Bridge Construction" shall govern the construction and management of this project as follows:

- Division 100 contains the Colorado Department of Transportation General Provisions. With the exception of General Provision Section 101, all other General Provisions Sections are not applicable to this Project and are hereby deleted, and shall be replaced with the General Contract Conditions.
- Division 200 through 700 are the Standard Specifications governing the work on this Project. All applicable sections and subsections shall be followed to control construction of this Project.

PROJECT SPECIAL PROVISIONS

Project Special Provisions listed herein take precedence over Specifications, Standard Provisions or Plans, and supplement or amend the referenced Standard Construction Specifications.

DEFINITION OF PROJECT MANAGER: The term “PROJECT MANAGER” shall refer to the City’s Project Manager. For all situations in which the Contractor requires clarification and direction (e.g. plan interpretation, changing field conditions, unknown utilities, etc.), the Contractor shall contact the Project Manager. The Contract Documents (plans, specifications, project special provisions, general conditions, reports, etc.) were prepared from and reference numerous sources. These sources use various terms to define the project’s ownership and management team (e.g. Project Manager, Inspector, Construction Project Manager, etc.) For purposes of this project, all of these terms shall mean the Project Manager as defined above. When the term “Engineer” or “Owner” is used, the Contractor shall contact the Project Manager, and the Project Manager will coordinate with the Engineer or Owner as needed.

PROJECT SPECIAL PROVISIONS (CONTINUED)

The following special provisions supplement or modify the Standard Specifications and take precedence over the Standard Specifications and plans.

| | <u>Date</u> | <u>Page</u> |
|---|-----------------|-------------|
| Index Pages..... | (May 24, 2022) | 2-3 |
| CDOT Standard Special Provisions | (May 24, 2022) | 4 |
| General Project Description | (May 24, 2022) | 5 |
| Performance of Safety Critical Work | (May 24, 2022) | 6-8 |
| Revision of Section 201 – Clearing and Grubbing..... | (May 24, 2022) | 9 |
| Revision of Section 202 – Removal of Trees | (May 24, 2022) | 10 |
| Revision of Section 202 – Removal of Bridge | (July 31, 2022) | 11-14 |
| Revision of Section 202 – Removal of Inlet..... | (May 24, 2022) | 15 |
| Revision of Section 202 – Removal of Fence | (July 31, 2022) | 16 |
| Revision of Section 202 and 412 – Removal and Replacement of Concrete Pavement .. | (May 24, 2022) | 17-18 |
| Revision of Section 203 – Excavation and Embankment..... | (July 31, 2022) | 19 |
| Revision of Section 208 – Water Control..... | (May 24, 2022) | 20-25 |
| Revision of Section 208 – Erosion Control..... | (June 28, 2022) | 26-36 |
| Revision of Section 208 – Watering and Dust Palliatives..... | (May 24, 2022) | 37 |
| Revision of Section 210 – Valve Box and Manhole Adjustments | (May 24, 2022) | 38-39 |
| Revision of Section 212 – Protection of Existing Vegetation (Special)..... | (July 31, 2022) | 40-50 |
| Revision of Section 212 – Seeding, Fertilizer, Soil, and Conditioner..... | (May 24, 2022) | 51-55 |
| Revision of Section 212 – Landscape Restoration | (May 24, 2022) | 56 |
| Revision of Section 213 – Wood Mulch | (June 28, 2022) | 57 |
| Revision of Section 214 – Planting | (June 28, 2022) | 58-64 |
| Revision of Section 250 – Environmental Health and Safety Management..... | (July 31, 2022) | 65-70 |
| Revision of Section 403 – Hot Mix Asphalt..... | (May 24, 2022) | 71 |
| Revision of Section 503 – Drilled and Vacuumed Caisson..... | (July 31, 2022) | 72 |
| Revision of Section 504 – Planter Walls..... | (July 31, 2022) | 73 |
| Revision of Section 514 – Fence (Special)..... | (May 24, 2022) | 74 |
| Revision of Section 522 – Thin Bonded Overlay (Polyester Concrete)..... | (May 24, 2022) | 75-87 |
| Revision of Section 522 – Duplex Coating System | (May 24, 2022) | 88-93 |
| Revision of Section 601 – Structural Concrete Coating (Anti-Graffiti)..... | (May 24, 2022) | 94 |
| Revision of Section 603 – Culverts and Sewers..... | (May 24, 2022) | 95 |
| Revision of Section 603 – Manholes and Inlets | (May 24, 2022) | 96 |
| Revision of Section 608 and 412 – Sidewalks, Curb Ramps, and Bikeways..... | (June 28, 2022) | 97-100 |
| Revision of Section 613 – Electrical Conductor Identification..... | (May 24, 2022) | 101 |
| Revision of Section 613 – Electrical Conduit – General..... | (May 24, 2022) | 102-103 |
| Revision of Section 613 – Electric Meter Pedestal Cabinet and Base | (May 24, 2022) | 104 |
| Revision of Section 613 – Lighting..... | (June 28, 2022) | 105-106 |
| Revision of Section 613 – Pull Boxes – General..... | (May 24, 2022) | 107-108 |
| Revision of Section 614 – Concrete Footing (Traffic Signal Pole)..... | (May 24, 2022) | 109 |

Contract Control No. 2021-PROJMSTR-0000693

May 24, 2022

| | | |
|--|-----------------|---------|
| Revision of Section 614 – LED Pedestrian Signal Heads (Count Down)..... | (May 24, 2022) | 110 |
| Revision of Section 614 – Traffic Control Devices | (May 24, 2022) | 111-113 |
| Revision of Section 614 – Traffic Signal Cabinet Base | (May 24, 2022) | 114 |
| Revision of Section 614 – Traffic Signal Controller and Cabinet..... | (May 24, 2022) | 115-116 |
| Revision of Section 614 – Ethernet Managed Switch | (May 24, 2022) | 117-118 |
| Revision of Section 614 – Uninterrupted Power Supply System..... | (May 24, 2022) | 119-127 |
| Revision of Section 614 – Emergency Vehicle Traffic Signal Priority Control System.. | (May 24, 2022) | 128-132 |
| Revision of Section 614 – Traffic Signal Poles – General | (May 24, 2022) | 133-134 |
| Revision of Section 614 – Telemetry (Field) | (May 24, 2022) | 135-137 |
| Revision of Section 614 – Closed Circuit Television Camera (Traffic Surveillance)..... | (May 24, 2022) | 140 |
| Revision of Section 620 – Field Facilities..... | (May 24, 2022) | 141 |
| Revision of Section 623 – Landscape Irrigation | (May 24, 2022) | 142-160 |
| Revision of Section 626 – Public Information Management (Tier II)..... | ((May 24, 2022) | 161-165 |
| Revision of Section 630 – Uniformed Traffic Control..... | (July 31, 2022) | 166 |
| Revision of Section 630 – Construction Zone Traffic Control..... | (July 31, 2022) | 167-171 |
| Revision of Section 630 – Portable Message Sign Panel | (July 31, 2022) | 172-173 |
| Revision of Section 622 – Site Furnishings..... | (July 31, 2022) | 174-177 |
| Revision of Section 708 – Structural Concrete Coating..... | (May 24, 2022) | 178 |
| Denver (Only) Noise Ordinance Permit Variance Application Template..... | (May 24, 2022) | 179-182 |
| Utilities | (May 24, 2022) | 183-189 |
| Force Account and Allowance Items..... | (July 31, 2022) | 190-191 |

Denver Parks and Recreation Department

The following specifications shall be followed for improvements adjacent to Parks properties. For this project that is the areas between northbound and southbound Speer and on the south side of Larimer adjacent to Creek Front Park.

SECTION 03 30 00 - CAST-IN-PLACE CONCRETE

SECTION 32 13 13 - CONCRETE WALKS, CURBS, AND MISCELLANEOUS FLATWORK

SECTION 32 80 00 - IRRIGATION SYSTEMS

SECTION 32 84 33 - AUTOMATIC IRRIGATION CONTROLLERS

SECTION 32 91 13 - SOIL PREPARATION

SECTION 32 92 23 - SODDING

Specifications can be downloaded from <https://www.denvergov.org/Government/Agencies-Departments-Offices/Agencies-Departments-Offices-Directory/Parks-Recreation/Planning-Community-Engagement/Construction-Design-Resources>

Should there be a discrepancy between these requirements and other referenced Standards and Specifications, the Contractor shall bring to the attention of the Engineer.

Contract Control No. 2021-PROJMSTR-0000693

May 24, 2022

PROJECT SPECIAL PROVISIONS - APPENDICES

Appendix A – “CCD Standard Materials Management Plan” Prepared by the Denver Department of Public Health and Environment, Environmental Quality Division, dated November 13, 2019 – Under Separate Cover

Appendix B – “Regulated Asbestos Contaminated Soil Standard Operation Procedure.” Prepared by the Denver Department of Public Health and Environment, Environmental Quality Division, dated May 24, 2019 – Under Separate Cover

Appendix C - “Clarification on Guidance for Reuse of Soil on City Projects.” Prepared by the Denver Department of Public Health and Environment, Environmental Quality Division, dated May 8, 2019 – Under Separate Cover

Appendix D - “Limited Environmental Screening, Larimer Street over Cherry Creek Bridge Replacement Project, Denver, Colorado.” Prepared by Pinyon Environmental, Inc., dated May 17, 2022 – Under Separate Cover

Appendix E - Geotechnical Investigation Report - Connecting Auraria Project, Denver, Colorado. Martinez & Associates Project No. 20-0132, March 7, 2022 – Under Separate Cover

Appendix F - MGPEC - Volume I - Pavement Design Standards & Construction Specifications

Appendix G - “Pre-Dig Checklist for Contractors”

CDOT STANDARD SPECIAL PROVISIONS

The listed Colorado Department of Transportation (CDOT) Standard Special Provisions are to be used for the project.

| | <u>Date</u> | <u>#Pages</u> |
|--|-------------------|---------------|
| Revision of Section 107 – Performance of Safety Critical Work | (October 1, 2021) | 3 |
| Revision of Section 202 – Removal of Bridge | (October 1, 2021) | 5 |
| Revision of Section 207 – Topsoil | (October 1, 2021) | 6 |
| Revision of Section 212 – Soil Amendments, Seeding, and Sodding | (October 1, 2021) | 18 |
| Revision of Section 214 – Nursery Stock Containers and Uprooted Cuttings | (October 1, 2021) | 10 |
| Revision of Sections 504 & 641 - Walls | (Nov. 2, 2021) | 27 |
| Revision of Section 601 – Structural Concrete | (October 1, 2021) | 1 |
| Revision of Section 601 – Concrete Mix Designs | (October 1, 2021) | 1 |
| Revision of Section 630 – Traffic Control Management | (March 18, 2022) | 1 |
| Revision of Section 703 - Aggregate | (Nov. 2, 2021) | 9 |

GENERAL PROJECT DESCRIPTION AND REQUIREMENTS CONNECTING AURARIA

GENERAL PROJECT DESCRIPTION

The purpose of the Connecting Auraria project is to replace the existing bridge over Cherry Creek and develop an improved multimodal connection between the Auraria Campus and lower Downtown Denver.

The project improves Larimer Street from 14th Avenue to Southbound Speer Boulevard. The scope of work for the project includes:

- Implementation of erosion and water control measures
- Implementation of vehicular, bicycle and pedestrian detours
- Demolition of the existing bridge, pavements, and sidewalks
- Construction of the bridge over Cherry Creek
- Construction of a buffered on-street 2-way bicycle facility
- Widened pedestrian areas
- Construction of a curbless street typical section
- Construction of storm sewer system improvements
- Implementation of permanent water quality facilities
- Construction of two new traffic signals at Speer Boulevard
- Enhanced street amenities including pedestrian lighting, landscaping and urban hardscape elements

PERFORMANCE OF SAFETY CRITICAL WORK

Performance of Safety Critical Work. The following work elements are considered safety critical work for this project:

- (1) Overhead girder erection
- (2) Overhead structure construction or repair
- (3) Removal of bridge
- (4) Temporary work: falsework, shoring that exceeds 5 feet in height, cofferdams, and temporary bridges.
- (5) Work requiring the use of cranes or other heavy lifting equipment to set girders, sound walls, make overhead repairs; also when construction materials are being lifted that may fall onto active traffic lanes.
- (6) Work operations such as pile driving and jack hammering which may create vibration and cause debris to fall onto traffic.
- (7) Work over or adjacent to river, stream, or other protected water way.
- (8) Urban work near and/or where pedestrian or bicycle pathways must be maintained during construction.

The Contractor shall submit, for review, an initial, detailed construction plan that addresses safe construction methods for each of the safety critical elements applicable to this project. The Engineer's review will be for general conformance with the plans, specifications, best management practices regarding safety of the operation and industry standards. When the specifications already require an erection plan, a bridge removal plan, or a removal of portion of bridge plan, it shall be included as a part of this plan. The detailed construction plan shall be submitted two weeks prior to the safety critical element conference described below. The construction plan shall be stamped "Approved for Construction" and signed by the Contractor. The construction plan will be reviewed for acceptance by the Engineer.

The Construction Plan shall include the following:

- (1) Safety Critical Element for which the plan is being prepared and submitted.
- (2) Contractor or subcontractor responsible for the plan preparation and the work.
- (3) Schedule, procedures, equipment, and sequence of operations, that comply with the working hour limitations.
- (4) Temporary work required: falsework, bracing, shoring, cofferdams, etc.
- (5) Underground, above grade, and overhead utilities identification and protective steps taken.
- (6) Communication plan as necessary with stakeholders, media, and the public.
- (7) Additional actions that will be taken to ensure that the work will be performed safely.

-2-

PERFORMANCE OF SAFETY CRITICAL WORK

- (8) Names and qualifications of workers who will be in responsible charge of the work:
- A. Years of experience performing similar work
 - B. Training taken in performing similar work
 - C. Certifications earned in performing similar work
- (9) Names and qualifications of workers operating cranes or other lifting equipment
- A. Years of experience performing similar work
 - B. Training taken in performing similar work
 - C. Certifications earned in performing similar work
- (10) The construction plan shall address how the Contractor will handle contingencies such as:
- A. Unplanned events (storms, traffic accidents, work accidents, etc.)
 - B. Structural elements that don't fit or line up
 - C. Work that cannot be completed in time for the roadway to be reopened to traffic
 - D. Replacement of workers who don't perform the work safely
 - E. Unexpected absence of critical management team
 - F. Equipment failure
 - G. Other potential difficulties inherent in the type of work being performed
- (11) Name and qualifications of Contractor's person designated to determine and notify the Engineer in writing when it is safe to open a route to traffic after it has been closed for safety critical work.
- (12) Erection plan or bridge removal plan when submitted as required elsewhere by the specifications. Plan requirements that overlap with above requirements may be submitted only once.

A safety critical element conference shall be held two weeks prior to beginning construction on each safety critical element. The Engineer, the Contractor, the safety critical element subcontractors, and the Contractor's Engineer shall attend the conference. Required pre-erection conferences or bridge removal conferences may be included as a part of this conference. Communications staff (Contractor or CDOT) shall also attend in order to address any public/media needs.

After the safety critical element conference, and prior to beginning work on the safety critical element, the Contractor shall submit a final construction plan to the Engineer for record purposes only.

The Contractor shall perform safety critical work only when the Engineer, or an authorized representative, is on the project site. The Contractor's Engineer shall be onsite to inspect and provide written approval of safety critical work for which he provided signed and sealed construction details. Unless otherwise directed or approved, the Contractor's Engineer need not be onsite during the actual performance of safety critical work, but shall be present to conduct inspection for written approval of the safety critical work.

When ordered by the Engineer, the Contractor shall immediately stop safety critical work that is being performed in an unsafe manner or which will result in an unsafe situation for the traveling public. Prior to stopping work, the Contractor shall make the situation safe for work stoppage. The Contractor shall submit an acceptable plan to correct the unsafe process before the Engineer will authorize resumption of the work.

When ordered by the Engineer, the Contractor shall remove workers from the project that are performing the safety critical work in a manner that creates an unsafe situation for the public. ~~in accordance with subsection 108.06.~~

Contract Control No. 2021-PROJMSTR-0000693

May 24, 2022

-3-

PERFORMANCE OF SAFETY CRITICAL WORK

Should an unplanned event occur or the safety critical operation deviate from the submitted plan, the Contractor shall immediately cease operations on the safety critical element, except for performing any work necessary to ensure worksite safety, and provide proper protection of the work and the traveling public. If the Contractor intends to modify the submitted plan, he shall submit a revised plan to the Engineer prior to resuming operations.

All costs associated with the preparation and implementation of each safety critical element construction plan will not be measured and paid for separately, but shall be included in the work.

The Contractor shall not be relieved from ultimate liability for unsafe or negligent acts or receive a waiver of the Colorado Governmental Immunity Act on behalf of the Department.

END OF SECTION

Contract Control No. 2021-PROJMSTR-0000693

May 24, 2022

**REVISION OF SECTION 201
CLEARING AND GRUBBING**

Section 201 of the Standard Specifications is hereby revised for this project as follows:

Subsection 201.02 shall include the following:

Clearing and grubbing shall include removal of trees less than 4-inches in diameter not designated to be protected, miscellaneous landscaping materials (including all rock mulch, organic mulch) sod, shrubs, plant materials, trees, riprap, and other materials within the work area not otherwise listed as a pay item.

Volunteer trees growing from the Speer Bridge abutment adjacent to the Larimer bridge shall be included in this work.

Work involving trees to remain shall conform to applicable provisions of the Tree Retention and Protection specification, included in the plans.

No tree removals shall take place until marked by Contractor and approved by the Project Manager.

Incidental concrete or other materials adjacent to the bridge shall be removed and included in this work.

Subsection 201.02, paragraph 2, shall be deleted and replaced with the following:

Removals shall be completed so that earthwork activities can begin, or as directed by the Project Manager.

Subsection 201.02, paragraph 3, shall include the following:

All tree stumps within the project limits will be ground, grubbed and removed to a depth of 24 inches below required subgrade elevation.

Subsection 201.02, paragraph 8, shall be deleted and replaced with the following:

Locate and suitably identify trees and improvements indicated to remain. No trees or shrubs shall be removed until marked and approved by the Project Manager.

END OF SECTION

Contract Control No. 2021-PROJMSTR-0000693

May 24, 2022

**REVISION OF SECTION 202
REMOVAL OF TREES**

Section 202 of the Standard Specifications is hereby revised for this project as follows:

Subsection 202.02 shall include the following:

This work includes the removal of trees 4” diameter and greater as identified on the plans or as directed by the Engineer. Trees shall be felled at the risk of the Contractor and disposed of offsite.

Subsection 202.12 shall include the following:

| Pay Item | Pay Unit |
|-----------------|-----------------|
| Removal of Tree | Each |

Removal of trees less than 4 inches in diameter will not be paid for separately but shall be included Section 201.

END OF SECTION

**REVISION OF SECTION 202
REMOVAL OF BRIDGE**

Section 202 of the Standard Specifications is hereby revised for this project as follows:

Subsection 202.01 shall include the following:

This work consists of removal of the existing bridge at Larimer Street over Cherry Creek and Cherry Creek Trail. Bridge removal shall consist of the complete removal of all superstructure and substructure elements unless otherwise shown on the plans and the removal of the access control fencing on top of the existing floodway walls as needed to facilitate installation of the new bridge superstructure.

Subsection 202.02 shall include the following:

The removal of the existing bridge shall be performed in a safe manner.

The Contractor shall take care to avoid damage to the existing retaining walls that are to remain in place. See the Nationwide Permit Verification, NWO-2022-00282-DEN for additional requirements.

When removal operations are located over a railroad or in proximity to any live water way, additional coordination with the railroad or other agency, United States Army Corps of Engineers (USACE), US Fish and Wildlife Service, US Forest Service, etc. shall be required.

The Contractor shall submit a Bridge Removal Plan to the Engineer, for record purposes only, at least 20 working days prior to the proposed start of removal operations. This Plan shall detail procedures, sequences, and all features required to perform the removal in a safe and controlled manner. The Bridge Removal Plan shall be stamped "Approved for Construction" and signed by the Contractor. The Bridge Removal Plan will not be approved by the Engineer.

The Bridge Removal Plan shall provide complete details of the bridge removal process, including:

- (1) The removal sequence, including staging of removal operations. Sequence of operation shall include a detailed schedule that complies with the working hour limitations.
- (2) Equipment descriptions including size, number, type, capacity, and location of equipment during removal operations.
- (3) Shoring that exceeds 5 feet in height, all falsework and bracing.
- (4) Details, locations and types of protective coverings to be used. The protective covering shall prevent any materials, equipment or debris from falling onto the property below. When removal operations are located over or in proximity to any live waterway, railroad, or pedestrian/bicycle path, additional width of protective covering sufficient to protect these facilities shall be required. Detailed methods for protection of the existing roadway facilities, including measures to assure that people, property, utilities, and improvements will not be endangered.
- (5) Detailed methods for protection of live waterways including minimization of turbidity and sedimentation, and protection of existing wetlands.
- (6) Detailed methods for mitigation of fugitive dust resulting from the demolition.
- (7) Details for dismantling, removing, loading, and hauling steel elements.

-2-
**REVISION OF SECTION 202
REMOVAL OF BRIDGE**

(8) Methods of Handling Traffic, including bicycles and pedestrians, in a safe and controlled manner.\

A Pre-Removal Conference shall be held at least seven days prior to the beginning of removal of the bridge. The Engineer, the Contractor, the removal subcontractor, the Contractor's Engineer, and the Traffic Control Supervisor (TCS) shall attend the Pre-Removal Conference. The Bridge Removal Plan shall be finalized at this Conference.

The Contractor's Engineer shall sign and seal (1) and (3) listed above in the final Bridge Removal Plan. Calculations shall be adequate to demonstrate the stability of the structure remaining after the end of each stage of removal, before traffic is allowed to resume in its normal configuration.

The final Bridge Removal Plan shall be stamped "Approved for Construction" and signed by the Contractor. The Contractor shall submit a final Bridge Removal Plan to the Engineer prior to bridge removal for record purposes only. The Contractor shall not begin the removal process without the Engineer's written authorization.

Submittal of the final Bridge Removal Plan to the Engineer, and field inspection performed by the Engineer, will in no way relieve the Contractor and the Contractor's Engineer of full responsibility for the removal plan and procedures.

Unless otherwise directed, the Contractor's Engineer need not be on site when bridge removal operations are in progress, but shall be present to conduct daily inspection for written approval of the work. The Contractor's Engineer shall inspect and provide written approval of each phase of the removal prior to allowing vehicles or pedestrians on, below, or adjacent to the structure. The Contractor's Engineer shall certify in writing that the falsework, bracing, and shoring conform to the details of the final Bridge Removal Plan. A copy of the certification shall be submitted to the Engineer.

The Contractor's Engineer shall inspect the bridge removal site and report in writing on a daily basis the progress of the operation and the status of the remaining structure. A copy of this daily report shall be available at the site of the work at all times, and a copy of the previous day's inspection report shall be submitted to the Engineer daily.

The Contractor shall have all necessary workers, materials, and equipment at the site prior to closing any lanes to traffic to accommodate bridge removal operations. While the lanes are closed to public traffic, work shall be pursued promptly and without interruption until the roadway is reopened to traffic.

Removal of hazardous material shall be in accordance with Section 250.

The Contractor shall take all steps to avoid contaminating state waters, in accordance with Revision to Section 208 – Water Control. The Contractor shall adhere to the requirements of the 404 permit to protect the existing floodway walls at all times during the project.

Should an unplanned event occur or the bridge removal operation deviate from the submitted bridge removal plan, the bridge removal operations shall immediately cease after performing any work necessary to ensure worksite safety. The Contractor shall submit to the Engineer, the procedure or operation proposed by the Contractor's Engineer to correct or remedy the occurrence of this unplanned event or to revise the final Bridge Removal Plan. The Contractor shall submit his Engineer's report in writing, within 24 hours of the event, summarizing the details of the event and the procedure for correction.

-3-
**REVISION OF SECTION 202
REMOVAL OF BRIDGE**

Before removal of the protective covering, the Contractor shall clean the protective covering of all debris and fine material.

Bridge removal may be suspended by the Engineer for the following reasons:

- (1) Final Bridge Removal Plan has not been submitted, or written authorization has not been provided by the Engineer to begin the removal.
- (2) The Contractor is not proceeding in accordance with the final Bridge Removal Plan, procedures, or sequence.
- (3) The Contractor's Engineer is not on site to conduct inspection for the written approval of the work.
- (4) Safety precautions are deemed to be inadequate.
- (5) Existing neighboring facilities are damaged as a result of bridge removal.

Suspension of bridge removal operations shall in no way relieve the Contractor of his responsibility under the terms of the Contract. Bridge removal operations shall not resume until modifications have been made to correct the conditions that resulted in the suspension, as approved in writing by the Engineer.

The Contractor shall notify all emergency response agencies of the proposed removal work and any detours 24 hours in advance of work. This shall include the Colorado State Patrol, local Police Department, local Fire Department, all local ambulance services, and the Sheriff's Department, as appropriate.

All required traffic control devices, night time flagging stations, barricades and VMS signs shall be in place, with detours in operation, prior to the beginning of removal operations each day. Night work shall conform to the requirements of the MUTCD, Parts 1, 5, and 6.

Prior to reopening the roadway to public traffic, all debris, protective pads, materials, and devices shall be removed and the roadways swept clean.

Explosives shall not be used for removal work without the written approval of the Engineer.

Removal shall include the superstructure, the substructure, which includes the pier, the abutments and wingwalls, the bridge rail, any approach slabs and sleeper slabs, approach guardrail and the safety fencing below the bridge at each abutment. Existing retaining walls adjacent to Cherry Creek trail shall remain in place and shall be protected from damage, as well as the Cherry Creek Trail pavements. Any damage caused by the Contractor to any portion of the structure not intended for repairs shall be repaired in kind by the Contractor at the Contractor's expense using means and methods approved by the Engineer with no allowance for contract time extension.

Contract Control No. 2021-PROJMSTR-0000693

May 24, 2022

-4-

**REVISION OF SECTION 202
REMOVAL OF BRIDGE**

Removal of the substructure shall be taken down to at least 1 foot below the natural existing or future ground surface at the lowest point of interface with the abutment in accordance with M-206-2, unless otherwise approved by the Engineer. Removal of pier shall be taken to maximum of 2 feet below stream bed or to top of footing, whichever is shallower. Where such portions of existing structures lie wholly or in part within the limits of a new structure, they shall be removed as necessary to accommodate the construction of the proposed structure. Holes resulting from substructure removal shall be backfilled with Structure Backfill (Class 1) to the adjacent existing grades. Holes resulting from pier removal shall be backfilled with Type M d50 Riprap (12 Inch) and grouted to match the existing steam channel.

All other materials removed from the existing structure shall become the property of the Contractor and shall be properly disposed of offsite at the Contractor's expense, unless otherwise stated in the plans.

Existing structures, facilities, and surrounding roadways shall not be damaged by the removal operations. Damage that does occur shall be repaired immediately at the Contractor's expense.

The Contractor shall protect and salvage the girder placard(s) and deliver to the Engineer as directed. The placard(s) shall be flame cut out of the girder, within 1-inch of the edge of the placard.

The Contractor shall protect and salvage the bridge rails and deliver to Rey Jiminez to the facility noted below. The Contractor shall notify Rey at least two weeks prior to scheduled delivery of the rails to the facility. The bridge rail to be salvaged shall be all aluminum portions including all nuts and bolts. Anchor bolts in concrete curb and concrete curb shall not be salvaged and shall be removed and disposed of as stated in this specification.

5440 Roslyn Street, Building C
Denver, CO 80126
Rey.Jiminez@denvergov.org, 303-709-4014

The Contractor shall remove and reset onto the new bridge the bike path trail "Larimer St" sign on the north and south side of the bridge. The signs shall be reset on the side of the deck approximately above the centerline of the trail.

Subsection 202.12 shall include the following:

Payment will be made under:

| Pay Item | Unit |
|----------------------|-------------|
| Removal of Structure | Each |

Payment for Removal of Structure will be full compensation for all labor and materials required to complete the work, including, preparation and implementation of the Bridge Removal Plan, inspection, equipment, debris handling and disposal, salvaging, handling and storage of salvable materials, handling and disposal of all hazardous materials, and disposal of non-salvable materials. Riprap will be paid separately.

Lighting required for nighttime operations will not be measured and paid for separately, but shall be included in the work.

END OF SECTION

Contract Control No. 2021-PROJMSTR-0000693

May 24, 2022

**REVISION OF SECTION 202
REMOVAL OF INLET**

Section 202 of the Standard Specifications is hereby revised for this project as follows:

Subsection 202.11 shall include the following:

Backfilling cavities left by removal of inlets shall not be measured and paid for separately but shall be included in the item Remove Inlet.

END OF SECTION

Contract Control No. 2021-PROJMSTR-0000693

May 24, 2022

**REVISION OF SECTION 202
REMOVAL OF FENCE**

Section 202 of the Standard Specifications is hereby revised for this project as follows:

Subsection 202.01 shall include the following:

Removal of portions of decorative fencing adjacent to existing bridge.

Subsection 202.02 shall include the following:

Decorative fencing shall be removed to nearest posts with clean cuts, and care shall be taken to not damage fencing to remain. Fence posts where fencing has been removed shall be restored to a smooth finished surface by welding, sanding, grinding, and painting as necessary.

Care shall be taken to limit damage of removed fence and fence to remain. Contractor shall coordinate with Engineer to determine if fence shall be stockpiled for pick-up by others.

Subsection 202.11 shall include the following

Removal of decorative fence will be measured and paid for by the linear foot of fence removed and shall include restoration of existing fencing to remain. Removal of decorative fence shall be paid for as Removal of Fence (Special).

Subsection 202.12 shall include the following

| Pay Item | Pay Unit |
|------------------|------------------|
| Removal of Fence | Linear Foot (LF) |

END OF SECTION

Contract Control No. 2021-PROJMSTR-0000693

May 24, 2022

**REVISION OF SECTIONS 202 AND 412
REMOVAL AND REPLACEMENT OF CONCRETE PAVEMENT**

Sections 202 and 412 of the Standard Specifications are hereby revised for this project as follows:

In Subsection 202.02 delete the sixth paragraph and replace with the following:

The areas of concrete pavement to be removed shall be isolated in both the longitudinal and transverse directions by the double saw cut method of sawing in accordance with FHWA's publication entitled "Guide for Full-Depth Repairs". Sawing shall be accomplished with the use of a diamond blade saw or approved equivalent. Sawing of the concrete pavement shall be done to a true line, with a vertical face, unless otherwise specified. Sawing shall be full depth and shall go through the existing tie-bars and dowel bars, leaving free vertical edges at the limits of the removal.

After sawing has been completed, the deteriorated concrete shall be lifted vertically from its position unless otherwise approved by the Engineer. Pavement breakers or jackhammers shall be used in the removal process where lifting is not possible. All loose materials shall be removed from the repair area. Removed concrete slabs and excavated soils shall become the property of the Contractor and shall be disposed of in accordance with subsection 202.07.

After concrete pavement is removed, the underlying material will be evaluated by the Engineer. Unsuitable material shall be removed in accordance with subsection 206.03 and replaced with aggregate base course of the class and depth specified in the Contract.

Subsection 202.11 shall include the following:

Removal of concrete pavement will be measured by the square yard, completed to the required depth, and accepted.

Subsection 202.12 shall include the following:

Payment will be made under:

| Pay Item | Pay Unit |
|------------------------------|-----------------|
| Removal of Concrete Pavement | Square Yard |

Payment for Removal of Concrete Pavement will be full compensation for all work and materials required to complete the item, including sawing, removing, and disposal of the concrete pavement.

Structure excavation for removal of unsuitable material will be measured and paid for in accordance with subsection 206.07.

-2-

**REVISION OF SECTIONS 202 AND 412
REMOVAL AND REPLACEMENT OF CONCRETE PAVEMENT**

Subsection 412.13 shall include the following:

Dowel bars and tie bars for replaced concrete pavement shall be placed in accordance with Standard Plan M-412-1 unless otherwise directed by the Engineer. To anchor dowel bars and tie bars, holes shall be drilled into the sawed face of the existing slab, perpendicular to the joints. All alignments shall be measured and verified prior to the placement of concrete. Dowel baskets shall be used for joints in repair areas that exceed more than one panel replacement.

Compressed air shall be used to remove dirt and debris from all drilled holes. After cleaning and prior to bar insertion, epoxy grout shall be discharged to the back of the hole to force the grout forward. Sufficient epoxy grout shall be injected into the back of the hole in order to cover the bar over the entire length of embedment. Each bar shall be twisted a minimum of one full turn during insertion.

Subsection 412.17 shall include the following:

The smoothness of the replaced concrete shall be tested in accordance with subsection 105.07(a).

In subsection 412.23, first paragraph, delete the first sentence and replace it with the following:

The quantities of Concrete Pavement, Concrete Pavement (Patching), and Placed Concrete Pavement to be paid for under these items will be the number of square yards completed and accepted.

Subsection 412.24 shall include the following:

Payment will be made under:

| Pay Item | Pay Unit |
|------------------------------|-----------------|
| Concrete Pavement (Patching) | Square Yard |

Payment for Concrete Pavement (Patching) will be full compensation for all work and material required to place and finish the replacement concrete pavement in accordance with the Contract.

END OF SECTION

**REVISION OF SECTION 203
EXCAVATION AND EMBANKMENT**

Section 203 of the Standard Specifications is hereby revised for this project as follows:

Subsection 203.03, first paragraph, shall include the following:

Contractor shall furnish any additional fill needed to complete the project grading.

Except as noted below, embankment material shall meet the following requirements for Atterberg limits and gradation:

- (1) Maximum liquid limit of 40
- (2) Maximum plasticity index of 10
- (3) A maximum of 35 percentage of material by dry weight passing the No. 200 sieve

Material shall meet AASHTO A-1, A-2-4, A-2-5, and A-3 soils.

In addition, the upper 2 feet of completed embankment material shall have a resistance value (R-Value) of at least 20 when tested by the Hveem Stabilometer (AASHTO T-190).

In subsection 203.04, add the following:

Excavated material from the project site may be unsuitable for re-use. Refer to PSP Section 250 and the Materials Management Plan (MMP). For bidding purposes, this is assumed to be the following:

- 75% of excavated material is suitable for re-use.
- 25% of excavated material is unsuitable but not classified as Regulated Asbestos Contaminated Soil (RACS). Non-RACS unsuitable material shall be hauled by the Contractor to the Denver Arapahoe Disposal Site (DADS). This will be paid for as 250 - Solid Waste, Excavation, Loading and Transportation. Refer to PSP Section 250.
- 10% of the unsuitable material is classified as Regulated Asbestos Contaminated Soil (RACS). RACS material shall be hauled by the Contractor to the Denver Arapahoe Disposal Site (DADS). This will be paid for as 250 - RACS Excavation, Loading and Transportation. Refer to PSP Section 250.

END OF SECTION

REVISION OF SECTION 208 WATER CONTROL

Section 208 of the Standard Specification is hereby revised for this project to include the following:

The work consists of controlling groundwater, stormwater in-flow, and instream flows during construction, including minimizing sediment entrainment and turbidity of stream flows originating from construction activity. The Contractor shall obtain all necessary permits for instream platforms. The Contractor shall schedule work to ensure adequate time for obtaining permits.

PART I: SUBMITTALS

In addition to the project stormwater management plan (SWMP), the Contractor shall submit a separate water and sediment control plan. The water and sediment control plan shall include location, height, and type of construction materials and best management practices (BMPs) for placement and removal of stream protection, channel diversion, coffer dams, as the Contractor deems necessary to complete the work listed in the commencement and completion of work while protecting existing infrastructure designated to remain including retaining walls and trails.

PART 2: PRODUCTS

Instream construction access, dams, or diversions shall be allowed during low flow season only. The size of dams, berms, dikes, and diversion channels shall be minimized to the extent practical. Instream construction access, dams, or diversions shall be constructed with clean material (e.g., barrier, clean rock, sheet piling, plastic sheeting, or sandbags) to protect water quality. Onsite materials within the limits of construction may also be used to construct temporary dams and berms if appropriate sediment control is achieved and maintained, assuming onsite materials are free of any solid wastes or contaminants. The Contractor may be required by the Project Manager, at no additional cost to the Project, to provide additional protection of water control facilities, if in the opinion of the Project Manager, existing control appears inadequate or is not in conformance with the sediment or water control plan. Water containing elevated levels of sediments generated from the work area shall be treated prior to discharge from the site using filtering mechanisms as approved by the Project Manager. In no instance shall any dams, berms, dikes, or diversion channels be left unprotected.

PART 3: EXECUTION

Cherry Creek and associated wetlands are waters of the US under the jurisdiction and regulation of the US Army Corps of Engineers. If there are any impacts beyond those shown on the plans and as authorized under the project's Nationwide 404 Permit, the Project Manager shall be contacted immediately, and all work shall stop. The Contractor is responsible for the stability of all work elements, temporary and permanent, for all phases of the project, and for all flow conditions. All Contractor activities must be constructed to withstand a flow equal to or greater than twice the 2-year event and must not restrict or impede the passage of flows. All permits shall be onsite during construction. The Contractor and all workers and equipment operators associated with river operations shall be familiar with all the conditions (regional, general, and special requirements) of the 404 permit, Colorado Discharge Permit System (CDPS) permit, and dewatering permit.

-2-

**REVISION OF SECTION 208
WATER CONTROL****PART 4: CDPHE-WQCD DISCHARGE PERMITTING**

In order to access and remove the in-stream piers or otherwise conduct work within the ordinary high water mark of Cherry Creek, it is possible that the Contractor will need to construct access pads or some other way to conduct the work in Cherry Creek, a water of the State. This may include installing sheet piling, a clean-water diversion, or other means to provide for a dry working area for work in Cherry Creek. This work will likely require the displacement of base surface water flows within the Cherry Creek channel to accommodate the work. It is likely that the work will be considered to be “in-stream” based on the following definition: “in-stream work is conducted on the bank of the stream and potentially including subsurface flow to the stream,” as provided in Section D of the Application Guidance Document, CDPS General Permits: Construction Dewatering (COG070000), Remediation Activities Discharging to Surface Water (COG315000), or Remediation Activities Discharging to Groundwater (COG316000). Due to the complexity of permitting with the Colorado Department of Public Health and Environment (CDPHE) – Water Quality Control Division (WQCD), the Contractor is highly encouraged to coordinate with the Project Manager and the WQCD as soon as possible after Project award to discuss the permitting strategy for the project.

Based on the above description, work within Cherry Creek that may displace base flows is likely to be considered in-stream. In-stream work should be conducted under a Construction Dewatering Discharge General Permit (COG080000), as the surface water is likely influencing the quality and quantity of water that will be encountered. This permit generally has minimal treatment requirements, as the assumption that water coming from a surface water and placed back into a surface water is not going to result in adverse impacts to the receiving stream’s water quality. In addition, a Construction Activities Stormwater Discharge Permit (CASDP) permit is required for this work. It is anticipated that treatment would be through the installation of BMPs identified in the SWMP or the Contractor’s water control plan, in accordance with the CASDP. Regardless, the Contractor must comply with the permit requirements at all times. Cost to secure a CDPHE-WQCD permit and all associated compliance requirements such as but not including compliance sampling and reporting, shall not be paid for separately but shall be included in the cost of the work.

PART 5: GENERAL

Construction shall be conducted as not to impede movement of aquatic species. Fish passage shall be provided. The Contractor shall install protective netting or screening over water intake devices or other equipment to prevent fish of all life stages from being entrained, killed, or harmed. During all phases, the Contractor must not restrict flows and must maintain a natural streambed to include features (i.e., baffles) to allow for fish passage, including passage through temporary pipe diversions. The streambed and banks shall be protected during all phases of construction and project operations and restored according to plans. The final grade of the streambed shall have a natural streambed and include features for fish passage. Cost to protect and restore the river shall not be paid for separately but shall be included in the cost of the work. Any work in the river shall follow all applicable federal and state permits, including local requirements and regulations.

For all excavation, the Contractor shall provide suitable equipment and labor to remove water and shall keep the excavation properly dewatered, so the work can be carried on under dewatered conditions where required by the Plans and Specifications. Water and sediment control shall be accomplished in such a way that no damage is done to the adjacent banks.

-3-
**REVISION OF SECTION 208
 WATER CONTROL**

PART 6: LOW FLOWS

Construction will occur between October 1st through March 31st in anticipation of lower stream flows. The box and whisker plot below provide an overview of the distribution of monthly average flows along Cherry Creek.

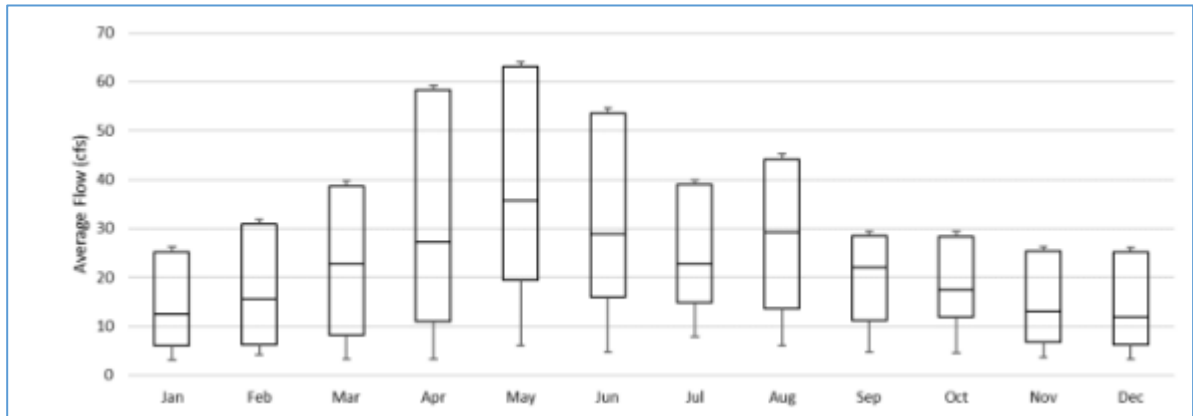

Distribution of Average Monthly Flows at USGS 06713500 (Cherry Creek at Denver, CO)

The Army Corps of Engineers performs annual summertime releases at Cherry Creek Reservoir to flush debris and sediment. Communication with Cherry Creek dam operations will be necessary.

The low flow season for the Larimer Street Bridge replacement shall be from October 1st through March 31st

Temporary access to the river consisting of berms is allowed as an aid to controlling water in work areas.

The design, placement and safety of the temporary access are entirely the Contractor's responsibility.

During in-stream work, flows must be maintained to allow for movement of aquatic species.

All excavations made as part of dewatering operations shall be backfilled with native fill or filter bedding material and compacted to 95 percent of maximum density (AASHTO T-99). Areas excavated for the purpose of substructure demolition shall be backfilled as shown on the plans.

PART 7: STORM FLOWS

Water control measures shall be capable of passing a flow equal to two times the 2-year storm event. The Contractor shall conduct operations in such a manner that storm waters may proceed uninterrupted along their drainage courses. The Contractor shall investigate the risk arising from such waters and plan the work accordingly. The Contractor's operations shall not restrict any flows or cause any backwater conditions. Any damage done during storm flows to temporary, existing, completed or partially completed structures or resulting from the Contractor's operation shall be repaired at the Contractor's expense.

-4-

**REVISION OF SECTION 208
WATER CONTROL**

There are existing and proposed storm sewer outlets within the project limits. The Contractor shall confirm estimated flows from each of the outlets and account for this storm water in their water control plan.

PART 8: SEDIMENT CONTROL

The Contractor shall minimize sediment entrainment within the river and diversion pipes and shall minimize downstream turbidity in the river beyond the approved cofferdam and associated construction activities through the use of protected control structures or BMPs. Such protection shall be maintained throughout the duration of use during the project and consist of, but not necessarily be limited to, geotextile fabrics, riprap, and conduits.

In no instance shall construction activities or equipment be allowed to work in the river except for dates outlined in the commencement and completion of work or as approved by the Project Manager.

PART 9: HAZARDOUS MATERIALS

In no instance shall oil or other hazardous materials be allowed to enter any flowing or contained water in or adjacent to the project site or adjacent wetlands. No hazardous materials shall be stored in the river channel at any time.

PART 10: INVASIVE SPECIES

Equipment and gear that were previously used in another stream, river, lake, pond, or wetland, and that are to be used in or near the water on this project, shall be treated to prevent the spread of aquatic invasive species the species include, but are not limited to:

1. New Zealand Mud Snail
2. Zebra Mussels
3. Quagga Mussels
4. Whirling Disease

Equipment shall be treated including all parts of machinery and vehicles of all types and sizes that come into contact with live water. Gear that must be treated including boots, waders, tools, and all other materials and attire used previously in live water. The Contractor shall use one of the following treatments:

1. Remove all mud and debris from equipment (tracks, turrets, buckets, drags, teeth, etc.), then spray/soak equipment with a 1 to 15 solution of Quat 4 or Super HDQ Neutral institutional cleaner and water. Treated equipment should be kept moist for at least 10 minutes.
2. Remove all mud and debris from equipment as above, then spray or soak equipment and gear with water heated to a temperature greater than 140 degrees Fahrenheit for at least 10 minutes. Prior to moving such equipment onto the project site, the Contractor shall submit to the Project Manager a written list of equipment treated and a signed certification that it was treated using one of the two methods specified above.

-5-
**REVISION OF SECTION 208
 WATER CONTROL**

PART 11: MATERIAL AND EQUIPMENT STORAGE

The Contractor is responsible for all material and equipment maintenance and storage at the project site. At no time shall any equipment or material be stored in the river channel or in adjacent wetlands unless approved by the Project Manager. All material not installed and all equipment other than pumps to maintain water control shall be removed the channel and stored no closer than 25 feet from the top of the banks at the end of each workday unless approved by the Project Manager.

PART 12: METHOD OF MEASUREMENT AND PAYMENT

Subsection 208.12 shall include the following:

Payment will be made under:

| Pay Item | Pay Unit |
|-----------------|-----------------|
| Water Control | Lump Sum |

When the Contractor provides acceptable performance in accordance with these specifications, as determined by the Project Manager, partial payments for the pay item may be submitted as the work progresses. These partial payments will be made as follows:

- a. When 5 percent of the original Contract amount is earned, 25 percent of the amount bid for this item will be paid.
- b. When 10 percent of the original Contract amount is earned, 40 percent of the amount bid for this item, less all previous payments, will be paid.
- c. When 25 percent of the original Contract amount is earned, 50 percent of the amount bid for this item, less all previous payments, will be paid.
- d. When 75 percent of the original Contract amount is earned, 75 percent of the amount bid for this item, less all previous payments, will be paid.
- e. When 100 percent of the original Contract amount is earned, 100 percent of the amount bid for this item, less all previous payments, will be paid.

Failure to provide acceptable performance will result in withholding of progress payment for this item. Continued failure to perform will result in non-payment of the corresponding percentage of the original bid item and may result in suspension of the work in those areas affected until acceptable public information services are provided by the Contractor.

For the purpose of Dewatering, the term "original contract amount" as used above, shall mean the amount bid for the construction items on this Contract, not including the amounts bid for environmental health and safety, temporary drainage, construction surveying, mobilization, public information services and force account items.

Contract Control No. 2021-PROJMSTR-0000693

May 24, 2022

-6-
REVISION OF SECTION 208
WATER CONTROL

Payment will be full compensation for all work necessary to complete the temporary access into the waterway, including all measures implemented to protect completed work, protect and restore the river bed, and minimize sediment entrainment in the river within the project limits, and minimize turbidity in the river beyond the project limits, including but not limited to temporary shoring (if required), diversion berms (earthen, sheet pile or pipes), earthwork, geotextile fabrics, riprap, dewatering wells, pumps, associated grading, revegetation, compliance with associated permits and local, state, and federal regulations, and all work associated with the river banks protection and cleanup.

Payment under this item includes multiple mobilizations if deemed necessary based on the Contractor's construction schedule.

END OF SECTION

**REVISION OF SECTION 208
EROSION CONTROL**

Section 208 of the Standard Construction Specifications is hereby removed in its entirety and replaced with the following:

PART I: DEFINITIONS

Definitions used for this Section shall consist of those listed in Title 1 of the City and County of Denver "Standard Specifications for Construction, General Contract Conditions", 2011 edition.

Definitions used for this Section hereby incorporate those identified within the City and County of Denver Construction Activities Stormwater Manual (CASM).

Additional Definitions applicable to this Section are listed heretofore:

Basis of Payment: The terms under which "Work" is paid, as a designated "Pay Item" in accordance with the quantity measured and the "Pay Unit."

Best Management Practices (BMPs): Schedules of activities, prohibitions of practices, installation of devices, maintenance procedures, and other management practices deployed to stabilize the construction site to prevent or reduce the pollution of State Waters (see definition below). Stormwater BMPs can be classified as "structural" (i.e., devices installed or constructed on a site) or "non-structural" (procedures, such as modified landscaping practices).

Colorado Department of Health and Environment (CDPHE): State of Colorado, Water Quality Control Division responsible for issuance of State Construction Stormwater Permit, Dewatering and Discharge of Groundwater, and Air Pollution Emissions Notice (APEN) for fugitive dust.

Construction Activities Stormwater Discharge Permit (CASDP): Permit issued by the City for compliance with City & County of Denver Revised Municipal Code and Department of Public Works Rules & Regulations concerning the discharge of pollutants in storm generated runoff from construction sites to Municipal Separate Storm Sewer System (MS4, see definition below) or State Waters, via the Municipal Separate Storm Sewer System (MS4).

Construction Activities Stormwater Manual (CASM): City and County of Denver Construction Activities Stormwater Manual (CASM), 2010 edition.

Colorado Department of Transportation (CDOT): State agency that has published standards for Erosion Control with accompanying Erosion Control Supervisor certification courses.

Erosion Control Supervisor (ECS): The Erosion Control Supervisor is assigned by the Contractor to perform duties as described in this Section. The ECS shall be properly trained in BMPs per requirements of Part V below, and shall be under the direction of a Professional Engineer licensed in the State of Colorado when performing any modifications to the Project Stormwater Management Plan (SWMP), as required by CDPHE.

Final Stabilization: Point of construction when all ground surface disturbing activities at the site have been completed and uniform vegetative cover has reached 70% of pre-disturbance vegetative cover (as judged by comparison to nearest fallow vegetation), or equivalent permanent features have been employed. At this point, all temporary BMPs can be removed, all construction and equipment maintenance wastes have been disposed of properly; and all elements of the Stormwater Management Plan have been completed.

-2-

**REVISION OF SECTION 208
EROSION CONTROL**

Major SWMP Modification: Changes to the original SWMP that removes or adds additional area to the Project, or modifies the hydrology or drainage of the Project. A Major SWMP Modification requires the submission of revised Stormwater Management Plan (SWMP) elements to the Permit Authority for review and approval. Any adjustments to a SWMP must be performed either by or under the direction of a Professional Engineer licensed in the State of Colorado.

Minor SWMP Modification: Modification to the SWMP that does NOT increase the scope or change hydrology of the Project but: modifies/improves specific BMPs in use at site, indicates progression in phasing of the Project, or specifies relocation of previously approved BMPs within the Project. Any adjustments to a SWMP must be performed either by or under the direction of a Professional Engineer licensed in the State of Colorado.

Municipal Separate Storm Sewer System (MS4): A conveyance or system of conveyances (including roads with drainage systems, municipal streets, catch basins, curbs, gutters, ditches, man-made channels, or storm drains):

- a) owned or operated by a State, city, town, county, district, association, or other public body (created by or pursuant to State law) having jurisdiction over disposal of stormwater or other wastes, including special districts under State law such as a sewer district, flood control district or drainage district, or similar entity, or a designated and approved management agency under Section 208 of the Federal Clean Water Act that discharges to State Waters;
- b) designed or used for collecting or conveying stormwater;
- c) which is not a combined sewer; and
- d) which is not part of a Publicly Owned Treatment Works (POTW).

Permit Authority: The Department authorized by the City to review and process CASDP Applications for Capital and/ or governmental sponsored Projects. The responsible City department serving as the Permit Authority is the Engineering, Regulatory and Analytics Office. As a clarification, the Development Services Department of the City serves as the point of intake and permit processing center.

Permit Enforcement Authority: The Department authorized by the City to inspect and enforce CASDP Rules and Conditions for all construction Projects within the City's MS4 Boundary. The responsible City department serving as the Permit Enforcement Authority is the Wastewater Management Division of the Department of Public Works.

State Construction Stormwater Permit: Colorado Revised Statutes require that all construction sites/development Projects, which, by definition, disturb one or more acres in area, shall be covered by a State issued general permit for construction activities. Information on the application requirements for the State permit can be obtained by phone at 303-692-3500; or by visiting their offices located at 4300 Cherry Creek Drive South, Denver, CO 80246 – 1530. or on the Web at: <https://www.colorado.gov/pacific/cdphe/news/water-quality-permits>

State Waters: Any and all surface waters which are contained in or flow in or through this State, not to include waters in sewage systems, waters in treatment works of disposal systems, waters in potable water distribution systems, and all water withdrawn for use until use and treatment have been completed.

-3-

REVISION OF SECTION 208 EROSION CONTROL

Examples of State Waters include, but are not limited to, perennial streams, intermittent or ephemeral gulches and arroyos, ponds, lakes, reservoirs, irrigation canals or ditches, wetlands, stormwater conveyances (when they discharge to a surface water), and groundwater.

Stormwater Management Plan (SWMP): The Stormwater Management Plan contains the requirements necessary to accomplish all the following:

The SWMP establishes a minimum standard to construct, install, maintain, and remove required BMPs during the life of the Contract to prevent or minimize pollution of stormwater due to erosion, sediment transport, and construction related pollutant generated during all phases of the Project. A SWMP consists of the following elements:

- (i) CASDP Narrative Worksheet with Narrative Report. The Narrative Report and supporting documents should fully address the methods to be used to prevent sediment, debris, and other pollutants from entering the MS4 and/ or State Waters in and around the Project area. Proposed structural and non-structural BMPs should be described with sufficient implementation detail to insure that the logical phases of the proposed construction Project meet the performance standards listed in the CASM.
- (ii) Proposed site drawings and Best Management Practice (BMP) installation details as they apply to the site conforming to the Urban Storm Drainage Criteria Manual, Vol. 3, "Best Management Practices", most current version as issued by the Urban Drainage and Flood Control District (UDFCD), or those established by the City's Department of Public Works. If erosion control drawings were included within the bid documents for the Project, they shall be used for bid purposes and initial planning/ deployment of BMPs on the Project. If provided drawings are signed/ sealed by a Professional Engineer, they have been pre-approved by the Permit Authority and may be used without revision for purposes of submitting for CASDP. If provided drawings do not have signature/ seal of Professional Engineer licensed by the State of Colorado, they will require revision by the Contractor with Professional Engineer signature/ seal prior to submission to the City and County of Denver for CASDP.
- (iii) Supporting documentation related to proposed BMPs that are not currently identified in UDFCD Vol. 3 or as otherwise published by the City.

Any preparation of or adjustments to a SWMP must be performed either by or under the supervision of a Professional Engineer licensed in the State of Colorado. SWMP elements submitted to the City shall also meet currently established criteria of the CDPHE as the SWMP must meet all local, State and Federal requirements.

Substantial Completion of Erosion Control: Point of construction when permanent BMPs have been installed, initial growth is in place, and the site is waiting for vegetative cover to reach 70% of pre-disturbance vegetative cover.

PART II: DESCRIPTION

This Work shall consist of constructing, installing, maintaining, and removing when required, BMPs during the life of the Contract until Final Stabilization to prevent or minimize erosion, sedimentation, and pollution of any waters including storm, drainageways, MS4, State Waters, and/ or wetlands. Work under this Section includes the Contractor obtaining required Permits, utilizing SWMP elements provided in the Contract, and/ or SWMP elements specifically prepared by the Contractor as defined herein. The work shall also consist of providing on-going maintenance and monitoring of the SWMP as may be necessary due to the specific and/or dynamic needs of the Project as well as meet all requirements set forth within the CASM.

-4-

REVISION OF SECTION 208 EROSION CONTROL

The Contractor shall coordinate the construction of temporary BMPs with the construction of permanent BMPs to assure economical, effective, and continuous erosion and sediment control and water pollution prevention throughout the construction period until Final Stabilization is achieved

When a provision of this Section or an order by the Permit Enforcement Authority requires that an action be immediate or taken immediately, it shall be understood that the Contractor shall at once begin effecting completion of the action and pursue it to completion in a manner acceptable to the Permit Enforcement Authority, and in accordance with applicable Permitting requirements.

PART III: MATERIALS

The materials to be used for BMPs shall conform to each specific detail as set forth within the Project SWMP or as noted on the Contract Drawings.

PART IV: EROSION CONTROL PERMIT STATUS

The current SWMP status for the Project is as follows:

The Contractor shall submit a complete SWMP and application to the Permit Authority to obtain the required CASDP. The Contractor shall use the provided "For reference only" erosion control drawings provided in the Contract as a starting point for preparation of required SWMP elements (as required for CASDP) and for general information as to the origin of pay items included in the Bid Documents. The included erosion control drawings have been previously reviewed by the Permit Authority, and the BMPs shown therein have been found to be generally acceptable by the Permit Authority.

It shall be the responsibility of the Contractor to prepare and acquire approval of a complete SWMP and obtain a CASDP from the Permit Authority prior to beginning construction. The Contractor is hereby made aware that the Permit Authority allots up to 3 weeks per review cycle for CASDP applications (2 or more review cycles are not uncommon).

Per CASDP requirements, the Contractor shall obtain the endorsement of a Professional Engineer licensed in the State of Colorado for preparation of the initial SWMP and/ or any proposed Major or Minor SWMP Amendments. This will require the Contractor to provide or retain a Professional Engineer or subcontract with the original Professional Engineer of the "For reference only" erosion control drawings.

Per definition, a Major SWMP Modification requires the submission of revised SWMP elements to the Permit Authority for review and approval.

Prior to construction, the Contractor shall obtain the required State Construction Stormwater Permit(s) as applicable.

PART V: CONSTRUCTION REQUIREMENTS

A) SCHEDULES:

At least 10 working days prior to the beginning of any construction work, the Contractor shall submit for approval a schedule for accomplishment of temporary and permanent BMPs shown in the SWMP. This schedule shall specifically indicate the sequence of clearing and grubbing, earthwork operations, and construction of temporary and permanent BMPs. The schedule shall include BMPs for all areas within the Project boundaries, including but not limited to, haul roads, borrow pits, and storage and other staging sites. Work shall not be started until the BMP schedule has been approved in writing by the Project Manager, and on site pre-construction inspection is performed and approved by CCD's NPDES inspector. Once the work has started, and during the active construction period, the Contractor shall update the schedule for all BMPs on a regular basis, and as required to keep the SWMP in compliance.

-5-

**REVISION OF SECTION 208
EROSION CONTROL**

B) CONSTRUCTION IMPLEMENTATION: The Contractor shall incorporate into the Project all BMPs that are appropriate for the current phase of work, as outlined in the accepted schedule.

C) UNFORSEEN CONDITIONS: The Contractor shall direct the ECS (under the supervision of a Professional Engineer licensed in the State of Colorado) to design and implement BMPs for correcting conditions unforeseen during design of the Project, or as possible for emergency situations, which arise during construction. The Project's SWMP, UDFCD Vol 3 standards and details, and CDOTs "Erosion Control and Storm-Water Quality Guide," and any approved modification to these documents as proposed by the Contractor, shall be used as reference documents for the purpose of designing appropriate BMPs. Measures and methods proposed by the Contractor to deal with unforeseen conditions shall be reviewed and approved in writing by the Permit Enforcement Authority and the Project Manager prior to implementation and construction.

In an emergency situation, the Contractor shall use best judgment for immediately responding to the emergency situation as it arises, and shall notify the Permit Enforcement Authority and ECS of the emergency situation and BMPs employed in response as soon as practical after installation.

D) PERMITS:

The Contractor shall obtain all required permits for the Project including those required by federal, state, and local agencies. The Contractor shall obtain (or transfer from the City when specified) required erosion control and water quality permits and shall be responsible for compliance with all requirements under any such permits.

E) EROSION CONTROL SUPERVISOR:

Contractor shall assign to the Project an employee or subcontractor to serve as Erosion Control Supervisor (ECS). The ECS shall be a person other than the Contractor's superintendent, foreman, or equivalent supervisory position. The ECS shall be experienced in aspects of BMP construction and have satisfactorily completed a Colorado DOT or equivalent ECS training program authorized by the City. Proof that this requirement has been met shall be submitted to the Project Manager at least ten working days prior to the beginning of any soil disturbance work. A list of authorized ECS training programs is available from the City upon request. Additionally, per definition, the ECS shall be under the direction of a Professional Engineer licensed in the State of Colorado when performing any modifications to the Project Stormwater Management Plan (SWMP).

The ECS shall be responsible for oversight of the implementation, maintenance, and revision of the SWMP for the duration of the Project. CCD requires the ECS to fulfill responsibilities as outlined by CDPS such as having financial control and authority to implement BMPs. The ECS's responsibilities shall be as follows:

- 1) Ensure compliance with all water quality permits or certifications in effect during the construction work.
- 2) Supervise the installation, construction, and maintenance of all BMPs specified in the Contract and coordinate the construction of BMPs with all other construction operations.
- 3) Direct the implementation of suitable BMPs as necessary to correct unforeseen conditions or emergency situations. Direct the dismantling of those features when their purpose has been fulfilled due to completion of each Project phase unless the Permit Enforcement Authority agrees that the features be left in place.
- 4) Attend the preconstruction conference, erosion control preconstruction inspection, Project scheduling meetings, weekly construction/ field meetings, substantial completion and final stabilization inspections, and other meetings regarding construction that could impact water quality.

-6-
REVISION OF SECTION 208
EROSION CONTROL

- 5) Evaluate all non-stormwater coming onto the site, such as springs, seeps, and landscape irrigation return flow. If such flow is identified, the ECS shall propose appropriate SWMP modifications to the Contractor to protect off-site water from becoming contaminated with sediment or other pollutants.
- 6) Coordinate with the Contractor to implement necessary actions to reduce anticipated or presently existing water quality or erosion problems resulting from construction activities.
- 7) Coordinate with the Contractor to ensure all labor, material, and equipment deployed to meet SWMP requirements is judged appropriately.
- 8) During construction, update and record the following items in the SWMP as changes occur:
 - (i) Construction boundaries (may require Major SWMP Modification)
 - (ii) Areas of disturbance (may require Major SWMP Modification)
 - (iii) Areas used for storage of construction materials, equipment, soils, or wastes.
 - (iv) Location of any dedicated asphalt or concrete batch plants.
 - (v) Location of construction offices and staging areas.
 - (vi) Location of work access routes during construction.
 - (vii) Location of borrow and waste.
 - (viii) Location of temporary and permanent stabilization

The ECS shall start a new site map before the current one becomes illegible. All site maps shall remain with the SWMP paperwork.

- 9) Amend the SWMP whenever there are: additions, deletions, or changes in locations of BMPs. SWMP revisions shall be recorded immediately. Items shall be dated and signed at time of occurrence. Specifically, amendments shall include the following:
 - (i) A change in design, construction, operation, or maintenance of the site which would require the implementation of new or revised BMPs; or
 - (ii) Changes when the SWMP proves to be ineffective in achieving the general objectives of controlling pollutants in stormwater discharges associated with construction activity.
 - (iii) Changes when temporary BMPs are no longer necessary from changes in Project phase and are removed. All inspection and maintenance activities or other repairs shall be documented.

All inspection and maintenance activities or other repairs shall be documented. The SWMP and documentation shall be kept on the Project site at all times.

- 10) Modify the site map with arrows to indicate direction of surface and storm water flowing across the Project site.
- 11) When adding or revising BMPs in the SWMP, amend the narrative to explain what, when, where, why, and how the BMP is being used, and add a detail to the SWMP.
- 12) If using existing topography, vegetation, etc. as a BMP, label it as such in the SWMP site map; amend the Narrative to explain when, why, and how the BMP is being used in the SWMP.
- 13) Record on the SWMP, and implement the approved plan for concrete and asphalt saw cutting, grinding, and milling containment and removal.

-7-

**REVISION OF SECTION 208
EROSION CONTROL**

- 14) Update the potential pollutants list in the SWMP throughout construction meeting CASDP requirements.
- 15) Spills, leaks, or overflows that result in the discharge of pollutants shall be documented on the inspection form. The ECS shall record the time and date, weather conditions, reasons for spill, and how it was remediated. The ECS shall immediately report to the Contractor and Project Manager the following instances of noncompliance:
- (i) Noncompliance which may endanger health or environment.
 - (ii) Spills or discharge of hazardous substance or oil which may cause pollution of the City MS4 or State Waters.
 - (iii) Discharge of stormwater which may cause an exceedance of a water quality standard.
- 16) Perform a thorough inspection of the stormwater management system at least every seven (7) days and within 24 hours after any precipitation or snowmelt event with the potential to cause surface erosion. If no land disturbing construction activities are present during a storm event, post-storm event inspections shall be conducted prior to commencing any new land disturbing construction activities, but no later than seventy-two (72) hours following the storm event. The inspection records shall be kept on-site in a written or previously approved format. Inspections shall be conducted during the progress of the work, during work suspensions, or until Final Stabilization of all disturbed areas is approved by Permit Enforcement Authority and shall include the following services at a minimum:
- (i) The construction site perimeter, disturbed areas, and areas used for material storage that are exposed to precipitation shall be inspected for evidence of, or the potential for, pollutants entering the drainage system. BMPs identified in the SWMP shall be observed to ensure that they are operating correctly.
 - (ii) The description of potential pollutant sources, and the BMPs identified in the SWMP, shall be revised and modified as appropriate based on the results of the inspection as soon as practicable after such inspection. Modification to the SWMP shall be implemented in a timely manner and in accordance with applicable Permit requirements.
 - (iii) The operator shall keep a record of inspections. Uncontrolled releases of sediment or polluted storm water or measurable quantities of sediment found off the site shall be recorded with a brief explanation as to the measures taken to prevent future releases as well as any measures taken to clean up the sediment that has left the site. Inspection records shall be made available to the City upon request. Note: documentation of uncontrolled releases at site DOES NOT alleviate any State or Federal requirements for reporting of discharges or upset conditions. Care shall be taken to ensure compliance with all regulatory requirements at site.
 - (iv) Seven (7) day inspections are required during construction and at all times until Final Stabilization has been achieved. Seeding and mulching of disturbed areas does NOT count as final stabilization until such time as 70% pre disturbed vegetative cover has been achieved. Sites with growth in place sufficient to deter erosion that have not yet achieved final stabilization may petition the City to grant an alternative inspection schedule while awaiting additional growth for final stabilization. These inspections must be conducted in accordance with the above paragraphs.

-8-
REVISION OF SECTION 208
EROSION CONTROL

F) APPLYING BMPs TO STABILIZE SITE:

The duration of the exposure of incomplete construction to the effects of weather shall be as short as practicable. BMPs such as: seeding, surface roughening, mulching, applying tackifier, use of geotextiles and matting, permanent landscaping, or other selected BMPs shall be applied within fourteen (14) calendar days of completion of grading/soil disturbance activities to stabilize the construction site unless disturbed area is within 100 feet of an MS4 or State Waters or has slopes of 3 to 1 or greater in which case BMPs shall be implemented within seven (7) calendar days of completion of grading activities. Disturbed areas where work is temporarily halted shall be temporarily stabilized within seven (7) days after the activity ceased unless work is to be resumed within thirty (30) calendar days after the activity ceased.

Clearing and grubbing operations shall be scheduled and performed to minimize both the area of the Project disturbed at a given time and the amount of time that disturbed areas remain open. BMPs such as temporary seeding are required between successive construction stages when disturbed areas will not be stable or active for thirty (30) calendar days or more. No payment will be made for additional work required because the Contractor has failed to properly coordinate the BMP schedule, thus causing previously stabilized areas to be disturbed by operations that could have been performed prior to the stabilization. Upon failure of the Contractor to coordinate the permanent BMPs with the grading operations in a manner to effectively control erosion and prevent water pollution, the Permit Enforcement Authority can suspend the Contractor's grading operations and the Project Manager can withhold monies due to the Contractor on current estimates until such time that all aspects of the work are coordinated in an acceptable manner.

G) WORK OUTSIDE LIMITS OF CONSTRUCTION: Non-contiguous areas outside the limits of construction that are used by the Contractor that include, but are not limited to, borrow pits, haul routes, storage and disposal areas, field offices, maintenance, batching areas, etc., shall have appropriate BMPs implemented by the Contractor at the Contractor's expense. Should said areas meet applicable CASDP Permit criteria, the Contractor shall obtain a separate CASDP or amend existing CASDP for each area as applicable at no additional expense to the City.

H) MAINTENANCE: The Contractor shall continuously maintain erosion and sediment control BMPs on a daily basis or as directed by the ECS so that they function properly during and after construction (including work suspensions) until Final Stabilization has been approved by the Permit Enforcement Authority. Maintenance includes, but is not limited to, the following items:

- (i) From the time seeding and mulching work begins until the date the Project has reached Substantial Completion of Erosion Control, the Contractor shall keep all seeded areas stabilized at all times. Any damage to seeded areas or to mulch materials shall be promptly repaired.
- (ii) All inspection sediment removal, and BMP maintenance activities to comply with all Federal, State & Local erosion control permit requirements until Final Stabilization is reached.
- (iii) All removal and replacement of existing BMPs due to damage to same suffered either by the contractor, outside agencies, the public, or acts of God.
- (iv) All required mechanical and/ or manual street sweeping.
- (v) Discretionary changes required of any regulatory enforcement officer.

If the Contractor fails to maintain the BMPs in accordance with the Contract, or as directed, the City may at the expiration of a period of 48 hours, after having given the Contractor written notice, proceed to maintain BMPs as deemed necessary. The cost thereof will be deducted from any compensation due, or which may become due to the Contractor under this Contract.

-9-

**REVISION OF SECTION 208
EROSION CONTROL**

I) MINOR SWMP MODIFICATIONS: Shall be made in the field by the Contractor and thoroughly documented in the Contractor's SWMP narrative and drawings. Should the Permit Enforcement Authority deem minor field modifications inadequate, the Contractor may be required to a) make specific modifications as requested by the Permit Enforcement Authority or b) return to the original approved design specifications. Minor SWMP Modifications are allowed, covered under the original CASDP, and required as part of standard maintenance and operation.

J) MAJOR SWMP MODIFICATION: The City reserves the right to require changes in the Work or Project Limits that may require a Major Modification to the SWMP and/ or CASDP due to unforeseen circumstances. Should this occur, the Contractor will be responsible for the following (as applicable) and applying for CASDP amendment:

- (i) Make required revisions to comply with changing Federal or State rulemaking if it occurs within timeframe of the Project
- (ii) Make required revisions due to unforeseen or unplanned conditions leading to deficient Drawings/ SWMP (hazardous materials encountered, landfills, expansion of work limits, etc.)
- (iii) Prepare revised SWMP elements endorsed by a Professional Engineer licensed in the State of Colorado.

K) SUBSTANTIAL COMPLETION OF EROSION CONTROL: When a CASDP is required for the Project, Substantial Completion of the Project as defined by the City and County of Denver General Contract Conditions cannot be reached until Substantial Completion of Erosion Control has been granted. Granting of Substantial Completion of Erosion Control must be requested by the Contractor and be approved by the Permit Enforcement Authority in the form of a "Certificate of Substantial Completion of Erosion Control".

L) FINAL STABILIZATION: Granting of Final Stabilization must be requested by the Contractor and be approved by the Permit Enforcement Authority. Other permanent soil stabilization techniques may be proposed, in writing, by the Contractor and used upon approval, in writing, by the Project Manager and Permit Enforcement Authority.

The Contractor shall follow the following procedures for approval of Final Stabilization:

- (i) The Contractor shall file Inactivation Request for Construction Activities Stormwater Discharge Permit (available within CASDP guidance documents) with the Permit Enforcement Authority.
- (ii) The Contractor shall coordinate with the Permit Enforcement Authority to hold a Final Inactivation Inspection.
- (iii) If passing, the Permit Enforcement Authority transmits a letter of approval for Final Stabilization.
- (iv) If not passing, the Permit Enforcement Authority transmits a letter of denial for Final Stabilization with associated inspection report to Contractor.
- (v) Stabilization, inspection and maintenance requirements shall continue until confirmation of having met final closure requirements have been granted in writing by the Permit Enforcement Authority.

When Final Stabilization has been reached, the Permit Enforcement Authority shall issue a "Certificate of Final Stabilization".

- (vi) Once the Inactivation request is approved by the City and County of Denver, the contractor can apply to close the State Stormwater Permit.

-10-
REVISION OF SECTION 208
EROSION CONTROL

M) FINAL ACCEPTANCE:

CASDP obligations (including reaching Final Stabilization) may hinder the ability to reach Final Acceptance for the overall Project as defined in the City General Contract Conditions.

PART VI: CONSTRUCTION OF BMPs

BMPs shall be constructed so that they conform to all requirements as set forth within the Project SWMP. They shall meet all requirements set forth within each BMP detail and shall be installed and maintained so that they function in an effective and operable manner.

PART VII: METHOD OF MEASUREMENT

No separate measurement will be made for the services or materials required to install, maintain, supervise or inspect erosion control devices as shown on the plans or in accordance with this specification.

Removal and disposal of sediment, concrete & trash that is or is not generated by construction activities, will not be measured separately but shall be included in the work.

Any excavation required for the removal of sediment from traps, basins, areas adjacent to silt fences and erosion bales, and any other cleanout excavation of accumulated sediment, and removal of check dams or storm drain inlet protection will not be measured separately but shall be included in the work.

PART VIII: BASIS OF PAYMENT

Work to furnish, install, maintain, supervise, inspect, replace (if not due to contractor negligence), remove, and dispose of BMPs specified in the Contract will be not be paid for separately but shall be paid for at the Contract bid lump sum price.

Payment will be made under:

| Pay Item | Pay Unit |
|-----------------|-----------------|
| Erosion Control | Lump Sum |

Payment will be full compensation for all work, materials and equipment required to furnish, install, maintain, supervise, inspect, remove, and dispose of BMP's. BMPs as deployed per the SWMP requiring replacement due to Contractor negligence and or carelessness shall be provided at the Contactor's expense.

Temporary BMPs required due to the Contractor's negligence, carelessness, or failure to install permanent controls as a part of the work as scheduled or for the Contractor's convenience, shall be performed at the Contractor's expense.

If the Contractor fails to complete construction within the approved contract time, no additional payment will be made for Section 208 for the period of time after expiration of the approved contract time. These items shall be provided at the Contractor's expense.

The cost for any corrective actions required by the State or City due to contractor's failure to obtain or comply with applicable Permits will be borne by the Contractor, including fines and penalties. In the case of failures on the part of the Contractor in controlling erosion, sedimentation, and/or water pollution, the City may provide the necessary corrective actions. All corrective action costs, including Project engineering costs, will be charged to the Contractor, and appropriate deduction will be made from the Contractor's monthly pay estimate.

-11-
REVISION OF SECTION 208
EROSION CONTROL

The Contractor however may submit a separate itemized Change Order for any required Major SWMP Modification proposed by the City during the course of the Project.

Erosion Control shall include all materials, labor and equipment necessary for the ECS to perform the work. Commute time shall be included in the work. ECS shall include all labor, Professional Engineering (includes supervisory Professional Engineer licensed in the State of Colorado), and/ or design fees to prepare modifications to Stormwater Management Plan(s), revise or amend Permits, coordinate with State and Local agencies, design special erosion control plans for emergency situations that develop during construction or unexpected weather conditions.

No additional payment will be made for multiple stabilized construction/ staging areas proposed by the Contractor.

Concrete washout structure, whether constructed or prefabricated, includes all work and materials required to install, maintain, and remove the item. This includes, but is not limited to: excavation, embankment, liner, erosion bales, fencing, signing, and containment and disposal of concrete washout and all other associated waste material.

Silt berm spikes and dike staples shall be included in the work

Storm drain inlet protection includes all work, materials, and equipment required to complete the item, including surface preparation, maintenance throughout the Project, and removal upon completion of the work.

Sweeping, when used as a BMP as shown in the Contract, will be a pickup broom or motorized equipment capable of collecting sediment, authorized by the Project Manager, used to remove sediment from the roadway or other paved surfaces. Operator costs shall be included in the work.

Stakes, anchors, connections, geotextile, riprap and tie downs used for temporary slope drains shall be included in the work.

Vehicle tracking pad includes all work, materials and equipment required to construct, maintain, and remove the entrance upon completion of the work. Aggregate and geotextile shall be included in the work.

Surveying of permanent BMPs shall be included in the work.

END OF SECTION

Contract Control No. 2021-PROJMSTR-0000693

May 24, 2022

**REVISION OF SECTION 209
WATERING AND DUST PALLIATIVES**

Section 209 of the Standard Specifications is hereby revised for this project as follows:

Delete the first paragraph in Subsection 209.07 and replace with the following:

Water for moisture-density control, landscaping, pre-wetting, and for dust palliatives will not be measured and paid for separately but shall be included in the cost of the work.

END OF SECTION

**REVISION OF SECTION 210
VALVE BOX AND MANHOLE ADJUSTMENTS**

Section 210 of the Standard Specifications is hereby revised for this project as follows:

Subsection 210.10 shall include the following:

The Contractor shall notify each utility company (Owner) prior to any construction that will involve the adjustment of its valve boxes or manholes.

Each Owner will mark all of its valve boxes and manholes that will be involved in the specified construction area.

Prior to commencing construction, the Contractor shall coordinate and conduct, with the Engineer and each Owner, an inspection of all impacted manholes and valve boxes. The purpose of this inspection will be to account for all valve boxes and manholes involved in the construction and determine their accessibility and condition. The Contractor shall provide traffic control for this inspection and for the final inspection. The Contractor shall coordinate construction with the Owner to allow sufficient time for the Owner to make all necessary repairs to, or supply replacements for valve boxes and manholes before construction begins in the area of the valve boxes and manholes. All parties shall agree on the condition of each valve box and manhole prior to construction.

The Contractor shall replace all valve box sections damaged or misplaced during construction with new valve box sections complying with the requirements of the Owner's specifications. The Contractor shall set each valve box to be adjusted so that it 1/4 inch to 1/2 inch below the final grade of the paved surface, or to the satisfaction of the Owner, and so that it is plumb over the operating nut of the valve.

The Contractor shall replace all manhole sections damaged or misplaced during construction with new manhole ring and cover complying with the requirements of the Owner's specification. The Contractor shall adjust each manhole so that it is 1/4 inch to 1/2 inch below the final grade of the paved surface, or to the satisfaction of the Owner.

Some adjustments may require the addition, removal, or replacement of a manhole or cone section. If manhole adjustment requires a manhole cone or barrel section to be added, removed, or replaced, this work will not be considered as "Adjust Manhole", but shall be considered "Modify Manhole".

The Contractor shall prevent tools, concrete, dirt, or debris of any kind from falling into the channel of the existing manhole. The Contractor shall clean or remove debris from downstream sewer that enters as a result of the Contractor's work.

When the project includes planing prior to resurfacing, the Contractor shall first lower all valve boxes and manholes below the surface to be planed and then adjust them up to final grade after the paving operation is complete.

Prior to the final inspection, the Contractor shall thoroughly clean all valve boxes designated for cleaning. This work shall be incidental to the Adjust Valve Box item.

The Contractor shall coordinate and conduct, with the Engineer and each Owner, a final inspection upon completion of construction. This inspection shall assure that all valve boxes and manholes are in compliance with these requirements, The Engineer will obtain the Owner's written approval before accepting the work.

Subsection 210.12 shall include the following:

The Contractor will be paid once for each valve box or manhole adjustment completed to final grade. There will not be separate measurement and payment for interim adjustments up or down to facilitate construction.

Contract Control No. 2021-PROJMSTR-0000693

May 24, 2022

-2-

**REVISION OF SECTION 210
VALVE BOX AND MANHOLE ADJUSTMENTS**

Subsection 210.13 shall include the following:

Payment will be made under:

| Pay Item | Pay Unit |
|------------------|-----------------|
| Adjust Valve Box | Each |
| Adjust Manhole | Each |
| Modify Manhole | Each |

END OF SECTION

**REVISION OF SECTION 212
PROTECTION OF EXISTING VEGETATION (SPECIAL)**

Section 212 of the Standard Specifications is hereby revised for this project as follows:

Subsection 212 shall include the following:

(a) General Requirements.

There should be daily supervision of field crews by the City Forestry Staff or Project Consulting Arborist during the critical phases of the project: for example, demolition of existing concrete; root pruning; construction of retaining walls and construction of new curb or sidewalk in tree protection areas.

If it appears that the completion of the construction may cause damage to the branches of any tree, the contractor shall contact the City Forester's Office. The Forester will make a determination as to whether such damage is imminent.

To prevent or minimize soil compaction, designated routes for equipment and foot traffic by work crews shall be determined prior to commencing construction activities, and shall be indicated in the tree protection plan to be submitted by Contractor. These routes shall be marked at the site, prior to commencement of construction, with tree protection fencing and signage as specified in Sections (e) and (f) (tree protection fencing).

Motorized equipment and trailers, including tractors, Bobcats, bulldozers, trackhoes, trucks, cars, and carts shall not be allowed access within tree protection areas. Should access be necessary within designated tree protection areas, the existing grade shall be covered with six (6) to eight (8) inches of wood mulch to help distribute the weight of equipment and to minimize soil compaction and rutting. Plywood and/or mulch is not acceptable bridging material for driving over exposed tree roots. Exposed tree roots shall not be driven over. The City Forester or Project Consulting Arborist shall be notified and shall approve of the access and driving surface prior to its use.

Materials and supplies shall not be stockpiled or stored within the tree protection area. Should temporary storage be necessary within designated tree protection areas, the existing grade shall be covered with double, overlapping sheets of $\frac{3}{4}$ inch thick plywood, or six (6) to eight (8) inches of wood mulch to help distribute the weight of materials or supplies and to minimize soil compaction.

Under no circumstances shall any objects or materials be leaned against or supported by a tree's trunk, branches, or exposed roots. The attachment or installation to trees of any sign, cable, wire, nail, swing, or any other material that is not needed to help support the natural structure of the tree is prohibited. Standard arboricultural techniques such as bracing or cabling that are performed by professional arborists are acceptable upon approval by the City Forester or Project Consulting Arborist.

-2-

**REVISION OF SECTION 212
PROTECTION OF EXISTING VEGETATION (SPECIAL)**

(b) Definitions.

1. **TREE PROTECTION AREA:** Generally, a tree protection area should consist of the ground encompassing from 1.5 (minimum) to 2.0 times the distance between the trunk and dripline, or one linear foot away from the trunk base for every inch diameter of the trunk, whichever is greater. (See section below.) Areas of ground covered by pavement, buildings, or other permanent structures where the presence of roots is minimal or negligible are excluded. The area under or within the tree's dripline is also referred to as the "Critical Zone" (see below).

Within groups of trees or where an array effect is present, there may be discontinuous (non-overlapping) perimeters of tree protection areas, which result in difficult to maintain or ineffective tree protection fencing. In these cases, even though tree protection areas do not overlap, they should be treated as though they do if the distance between the perimeters of such areas is less than thirty (30) feet. In effect, this will artificially enlarge the area of tree protection, but will result in a more clearly defined, manageable area.

2. **DRIPLINE:** The outermost edge of the tree's canopy or branch spread. The area within tree's dripline is at the ground under the total branch spread.
3. **CRITICAL ROOT ZONE:** Generally, all of the ground area included in the dripline.
4. **DIAMETER (CALIPER):** The size (in inches) of a tree's trunk is measured at: [1]- six (6) inches above grade for trunk diameters up to and including four (4) inches [2]-twelve (12) inches above grade for trunk diameters from four (4) inches up to and including eight (8) inches; and [3]-four and a half (4 ½) feet above grade for trunk diameters greater than eight (8) inches; in accordance with guidelines established in the "Guide for Plant Appraisal" (see Section c). All measurements should be rounded to the nearest inch.
5. **HIGH-VALUE SHRUB:** Any specimen shrub with an appraised value of \$100.00 or more.
6. **PROJECT CONSULTING ARBORIST:** An independent consultant with a degree in a field related to arboriculture, and at least five years field experience in tree preservation or on-site monitoring of public works or construction projects involving tree retention and protection. The consultant should be an active member in the American Society of Consulting Arborists and International Society of Arboriculture.

(c) Reference Standards and Guidelines. Contractor shall comply with applicable requirements and recommendations of the most current versions of the following standards and guidelines. Where these conflict with other specified requirements, the more restrictive requirements shall govern.

1. SNSI Z133.1-1998
American National Standard for Tree Care Operations
2. ANSI A300-1994
Standard Practices for Trees, Shrubs and Other Woody Plant Maintenance
3. NATIONAL ARBORIST ASSOCIATION STANDARDS
Pruning, Cabling and Bracing, Fertilization
4. GUIDE FOR PLANT APPRAISAL-8TH EDITION
Authored by the Council of Tree and Landscape Appraisers; published by the International Society of Arboriculture.

-3-
**REVISION OF SECTION 212
PROTECTION OF EXISTING VEGETATION (SPECIAL)**

CONSTRUCTION REQUIREMENTS

This section provides standards and guidelines for the retention and protection of trees and high-value shrubs for any proposed public works or construction project.

(a) Demolition of Existing Concrete. Caution should be used during removal of existing street, curb, gutter, sidewalk, drain inlets, and other concrete demolition, to minimize injury to tree root systems. The following procedures should be used when removing existing concrete.

1. Breaking of the existing concrete for removal should be done in a manner that will minimize ground disturbance and vibration.
2. Curbs and sidewalks within designated tree protection areas and critical root zones shall be removed by hand. When removing existing sidewalks and curbs, care should be taken to avoid injury to roots located under, over, or adjacent to paved surfaces.
3. Roots and root-trunk flares growing over curbs should not be injured during breaking of curbs and removal of debris. Wood and bark tissues shall not be injured by striking tissues with equipment.
4. During the removal of concrete, all root systems and soil areas exposed shall not be disturbed.
5. Motorized equipment and trailers, including tractors, Bobcats, bulldozers, trackhoes, trucks, cars, and carts are to be limited to access on the existing paved street only. Access is not allowed behind the curb within tree protection areas.
6. Should access be necessary within designated tree protection areas, the existing grade shall be covered with double, overlapping sheets of ¾ inch thick plywood, or six (6) to eight (8) inches of wood mulch to help distribute the weight of equipment and to minimize soil compaction and rutting. Plywood and/or mulch is not acceptable bridging material for driving over exposed tree roots. Exposed tree roots shall not be driven over. The City Forester or Project Consulting Arborist shall be notified and shall approve of the access and driving surface prior to its use.

(b) Construction of Sidewalks, Curbs, Concrete Paving and Drainage Inlets. The following procedures shall be used when constructing sidewalks, curbs, concrete paving, and drainage inlets.

1. Protect exposed roots from contamination by stabilization materials and concrete.
2. When excavating for the construction of inlets, excavated soil shall be deposited in trucks and hauled off or deposited temporarily in an area designated by the Owner's Representative. Excavated and fill soil shall not be deposited, even temporarily, on unprotected natural grade.

-4-

**REVISION OF SECTION 212
PROTECTION OF EXISTING VEGETATION (SPECIAL)**

3. After proper pruning (see section (d)), as needed, cover exposed roots within thirty (30) minutes to minimize desiccation. Roots may be covered with soil, mulch, or moistened burlap (7 ounce or equivalent), and shall be kept moist during the period until the final grade is established.
4. Where possible, sidewalks should be raised, narrowed, curved, or relocated to prevent cutting and removing major roots (e.g. roots greater than three inches in diameter).
5. Place a sheet of six (6) mil or thicker plastic over the grade within affected portions of tree protection areas prior to pouring concrete sidewalks, curbs, inlets, ramps, and driveway approaches. The plastic will assist in providing a non-leaching barrier between the concrete, soil and roots.
6. Construct new sidewalks on, or above, the existing grade instead of excavating into root zones. The new grade shall not interfere with sheet-flow drainage.
7. Limit grading to a maximum of two (2) inches fill over natural grade within critical root zones. Fill should consist of sandy loam topsoil. Clay soils shall not be used as fill. When using fill soil, the existing surface to receive fill should be scarified prior to filling. Any filling operation should not occur during water saturated soil conditions.
8. Existing soil may be used as a form for back of curb and gutter, with or without the use of a thin masonite-type form, although a masonite form is preferred. This will minimize excavation in the critical root zone and prevent undue injury to the roots. This method is unnecessary in areas outside the critical root zone. Place a layer of Typar BioBarrier between the curb and tree roots to help inhibit root growth that may exploit small cracks in the curb. Where appropriate, use curbs with discontinuous footing to maintain natural grade near the base of trees adjacent to the curbing, and to minimize injury to root flares.
9. Provide for easy concrete removal and replacement where an obvious raised root may cause sidewalk cracking in the future. This can be accomplished by installing an expansion joint on either side of the root or by etching the concrete on either side of the root to allow that particular section to be broken out and replaced. Compaction rating for the replacement walkway should not exceed 80% Proctor density. Tree roots will continue to slowly add girth every year; therefore, the base material needs to be malleable (e.g. suitable subgrade aggregates, crushed granite, or compacted sand) to prevent a fulcrum or pressure point which can crack or heave the walkway.

-5-

**REVISION OF SECTION 212
PROTECTION OF EXISTING VEGETATION (SPECIAL)**

10. Where appropriate, and under the direction of the City Forester or Project Consulting Arborist, root restricting barriers can be installed with a minimal amount of disturbance. There are several promising landscape relater materials used as barriers to root growth, especially away from sidewalks, curbs and streets. Three such materials are: (1) a stiff nylon woven fabric (Q899 nylon fabric with extra firm finish from Jason Mills, Westwood, NJ); (2) 14-mesh or smaller copper wire screen; and (3) Typar BioBarrier (REEMAY, Inc., Old Hickory, TN). The nylon fabric has holes approximately 1/26th-inchthick, with strands fused together. Copper screen has been shown to be effective in controlling seedling root growth. Typar BioBarrier is a commercial product developed specifically to control roots of trees, and consists of a felt-like spun-bounded polypropylene fabric to which polyethylene pellets are attached at one and a half (1 ½) by one and a half (1 ½) inch spacing. The pellets are impregnated with the herbicide Trifluralin and release it slowly over time (many years). After a two (2) foot deep, narrow trench is dug adjacent to the curb, sidewalk, or other structure involved, and after any affected roots are properly pruned (see section 6.04), the material of choice should be placed against the side of the wall closest to the roots that were severed (side of the wall farthest from the structure being protected). Note: This procedure should not be used if large, fabric and copper screen will constrict roots will be greatly stunted except for knobs that form against the barriers. The barrier should be installed at least eighteen (18) to twenty-four (24) inches deep (in a vertical plane).
11. In areas where roots have to be removed for construction of drain inlets or outfalls, roots shall be severed prior to excavation to eliminate unnecessary tearing of roots by equipment.
- A. Excavate soil by hand at the construction cut limit to a depth of thirty (30) inches or to the depth of the required root cut, whichever is less.
 - B. Prune roots as specified in section (d).
 - C. Protect exposed roots as specified in section (b) 5.
12. Concrete or chemicals spilled within tree protection areas should be completely removed. Contaminated soil shall be completely removed at the time of the spill and removed by hand without disturbance to root systems. Appropriate soil should be added as necessary to restore the grade.

(c) Irrigation or Utility Installation.

1. PROTECTION OF TREES AND HIGH-VALUE SHRUBS:
Contractor shall protect all trees and high-value shrubs from injury due to irrigation related work. All injuries to trees and high-value shrubs shall be mitigated to the satisfaction of the Owner, and, if appropriate in accordance with guidelines established in the "Guide for Plant Appraisal". All costs of such mitigating shall be charged to and paid by the Contractor.

-6-

**REVISION OF SECTION 212
PROTECTION OF EXISTING VEGETATION (SPECIAL)**

All irrigation lines shall be indicated on construction plans and pre-approved by the City Forester or Project Consulting Arborist. Unless absolutely necessary, no irrigation lines shall be located within 10 feet of any existing tree trunk. (See Section 2 below).

2. EXISTING TREES

- A. The City Forester or Project Consulting Arborist shall be notified prior to any trenching or excavation known or suspected to involve cutting of more than: [1]-two roots, three inches or more in diameter; and/or [2]-four roots between two (2) and three (3) inches in diameter. The City Forester or Project Consulting Arborist shall be notified immediately in the event that roots in excess of that described above are cut, torn, ripped, or otherwise injured.
- B. All trenching or other work under the dripline of any tree shall be done by hand or by other methods which will prevent breakage or other injury to branches and roots.
- C. Where it is necessary to excavate within the critical root zone of existing trees, contractor shall use all possible care to avoid injury to trees and tree roots. Excavation, in areas where two (2) inch diameter and larger roots occur, shall be done by hand with approved hand tools. Where possible, tree roots two (2) inches or larger in diameter shall be tunneled or bored under and shall be covered with moistened burlap to prevent excessive drying.
- D. Wherever a trenching machine exposes roots smaller than two (2) inches in diameter, such roots extending through the trench wall shall be hand pruned (see section (d)). All trenches within critical root zones shall be closed within twelve (12) hours-if this is not possible, the trench walls shall be covered with burlap and kept moistened. Prior to backfilling, Contractor shall contact the City Forester or Project Consulting Arborist to inspect the condition and treatment of roots larger than two (2) inches in diameter injured by trenching.
- E. Horizontal directional boring (auger tunneling), rather than open trenching, should be used for irrigation line or other utility installation within one half (1/2) foot linear distance from the trunk base for every inch of trunk diameter, if root disruption or utility installation occurs on no more than one side of the tree. If trenching or utility installation will occur on two or more sides of the trunk (e.g. N,S,E, or W), then horizontal directional boring should be used if line installation is within one (1) foot linear distance from the trunk base for every inch of trunk diameter.

-7-

**REVISION OF SECTION 212
PROTECTION OF EXISTING VEGETATION (SPECIAL)**

(d) Root Pruning. Tree roots shall not be pruned or cut unless their removal is unavoidable or absolutely necessary. The City Forester or Project Consulting Arborist shall be notified prior to any operation known or suspected to involve cutting of more than: [1]-two roots, three (3) inches or more in diameter; and/or [2]-four (4) roots between two (2) and three (3) inches in diameter. The City Forester or Project Consulting Arborist shall be notified immediately in the event that roots in excess of that described above are cut, torn, ripped, or otherwise injured.

1. Upon approval by the City Forester, prior to any excavation, removal of sidewalk, or other activity that will result in removal of soil and tree roots, all tree roots within a designated area will be pruned to a depth of fourteen (14) inches. Pruning shall occur with a Dosko Root Pruner, or equivalent, in accessible areas, and by hand in areas inaccessible to the root pruning machine. All other root pruning shall be done by hand with approved tools.
2. Removal or roots greater than one (1) inch diameter or parts of roots that are injured or diseased should be performed as follows:
 - A. Preserve the root bark ridge (similar in structure and function to a branch bark ridge). Directional root pruning is the recommended technique and should be used during hand excavation around tree roots. Roots are similar to branches in their response to pruning practices. With directional root pruning, objectionable and severely injured roots are properly cut to a lateral root, if possible, that is growing downward or in a favorable direction.
 - B. All roots needing to be pruned or removed shall be cut cleanly with sharp hand tools, with oversight by the City Forester or Project Consulting Arborist. No wound dressings shall be used.
 - C. Recommended root pruning tools:
 - Scissor-type lopper.
 - Scissor-type pruner.
 - Large and small hand saws.
 - Wound scriber.
 - Trowel or small shovel.
 - Garden Fork.
 - Hand broom.

-8-
**REVISION OF SECTION 212
PROTECTION OF EXISTING VEGETATION (SPECIAL)**

e) Root Pruning near Sidewalks:

1. Root pruning should be done carefully, by hand, to achieve the objective of reducing future sidewalk problems as well as preserving the trees. Removing anchoring roots or causing injuries in anchoring roots and root flares can cause future decay and windthrow hazards. Indiscriminate cutting of vigorous roots results in their resprouting so that several more new roots may grow from the cut end, back under the sidewalk, thereby reducing the time between sidewalk repairs. Roots can be managed in the ground without significant harm to trees, if care is taken to avoid injuries that lead to root and trunk decay.
2. Directional root pruning is recommended because it considers the tree's response to root pruning and decay. With directional root pruning, roots are cut to a large lateral, if possible, that is growing downward or in a more favorable direction. The pruned root ends will be less likely to resprout, since a large lateral can assume the new terminal role of the root.

Proper removal of selected roots or parts of roots can direct roots away from sidewalks in the future. Procedures for root pruning directly next to sidewalks are as follows:

- A. Hand dig a trench (6) to eight (8) inches in depth at the edge of the planting strip and sidewalk.
 - B. Remove all roots less than two (2) inches in diameter in this trench back to a desirable lateral root, preserving the root bark ridge. If careful excavation does not reveal a desirable lateral root within twelve (12) inches of the exposed root in question, then the exposed root shall be pruned properly so that a minimal amount of root is removed.
 - C. Small root bundles, the source of future sidewalk problems, should also be removed at this time.
3. All roots between two (2) and four (4) inches in diameter should be examined by the City Forester or Project Consulting Arborist in terms of their role in anchoring the tree.
 - A. All roots that contribute significantly to anchorage should be preserved. Remove all other roots in this size range to sound, downward growing lateral roots that are at least one half (1/2) the size of the root being removed.

-9-

**REVISION OF SECTION 212
PROTECTION OF EXISTING VEGETATION (SPECIAL)**

B. All roots larger than four (4) inches in diameter are to be preserved unless their removal is absolutely necessary. Preservation of large roots may require: [1]-reducing the sidewalk width near the root flare; and/or [2]-ramping or bridging the sidewalk over the roots to allow for root growth.

4. Tree guying subsequent to root pruning:

Upon review of on-site root pruning and constructing grading limits, the City Forester or Project Consulting Arborist shall determine if existing trees subject to root pruning should be guyed or otherwise stabilized. Contractor shall retain a qualified tree service company to complete tree guying and stabilization in accordance with National Arborist Association standards as referenced in Section 5.00. Tree Service Company shall be licensed by the City and County of Denver, through the City Forester's Office.

(f) Tree Protection Fencing.

1. Tree protection fencing should be installed two (2) feet behind the existing curb in areas where the street surface will be removed and replaced. Tree protection areas shall be designated on construction documents, and fencing locations should be staked for approval by the Construction Manager and City Forester or Project Consulting Arborist.
2. Tree protection fencing should be constructed of one of the following:
 - A. Galvanized chain-link – six (6) feet in height. Posts should be installed on ten (10) foot centers (maximum), at a depth of three (3) feet minimum. Installation of post shall not result in injury to surface roots or root flares of trees.
 - B. Colored (orange), molded plastic construction fencing, four (4) feet in height.
3. Fencing should be installed to completely surround the limits of tree protection area, and should extend at least ten (10) feet beyond the designated construction limits.
4. Tree protection fencing shall be installed prior to any site activity and shall remain until its removal is authorized by the City Forester or Project consulting Arborist.

-10-

**REVISION OF SECTION 212
PROTECTION OF EXISTING VEGETATION (SPECIAL)**

(g) Tree Protection Signage. A sign shall be mounted on tree protection fencing at fifty (50) foot intervals warning constructing personnel and the public to keep out of the tree protection area.

(h) Project Site Monitoring. As determined by the City Forester for projects of sufficient size to warrant such, a Project Consulting Arborist should be retained to enforce and monitor the Tree Retention and Protection objectives. The project site should be monitored a minimum of two (2) times weekly—more frequently at the start of the project until all procedures and specifications are understood and properly executed by all parties. Specific monitoring schedules should be developed at a Preconstruction meeting and modified as deemed necessary by the appropriate parties.

(i) Injuries to Existing Plants—Damage Penalties

1. TREE AND HIGH-VALUE SHRUB APPRAISAL:

All trees and high-value shrubs will be evaluated and appraised by the City Forester or Project Consulting Arborist, and a list of all tree values for the project will be on file in the Construction manager's office. Any tree or other plant requiring retention or protection that is not on the list shall be appraised by the City Forester or Project Consulting Arborist as necessary to comply with this damage penalty.

Documentation for appraisals will consist of:

[1]-measurement of plant size: [2]-identification by common and botanical names: [3]- Current condition (overall health, injuries, overt hazard status, etc.), and [4]- Location factors as described in the "Guide for Plant Appraisal". Photographs may be taken of certain trees and shrubs to document debilitating condition factors.

The threshold level for plants to be appraised shall be \$100.00; only those trees and shrubs estimated to have a monetary value greater than \$100.00 shall be appraised.

2. Trees and other plants designated as requiring retention or protection shall be identified and located on construction plans. Loss of, or partial injury to, any of these plants due to Contractor neglect or improper construction activities will result in liquidated damages for the assessed value of the tree as determined by the City Forester or Project Consulting Arborist.
3. Trees determined as requiring "general protection" or "special protection" in the construction areas and in other key locations should be clearly identified by the City Forester or Project Consulting Arborist. Loss or partial injury to any of these trees due to Contractor neglect or improper construction activities will result in liquidated damages for the assessed value of the trees as determined by the City Forester or Project Consulting Arborist. Injury to a portion of these trees will be assessed by the City Forester or Project Consulting Arborist and a corresponding portion of the liquidated damages will be assessed to the Contractor.

-11-
REVISION OF SECTION 212
PROTECTION OF EXISTING VEGETATION (SPECIAL)

4. A fine of one-thousand dollars (\$1,000.00) will be levied against the Contractor for each incident of construction damage (including construction traffic) within designated tree protection areas. Any fine shall be independent of any applicable liquidated damages for the assessed value of the tree or tree part.
5. Trees or roots visibly and unnecessarily injured will cause the Owner to withhold from the Contractor an assessed amount conforming to the requirements stipulated above, for a period of one full year. After that period the impact of the injury to any tree will be assessed by the City Forester or the Project Consulting Arborist.
6. If any trees or shrubs designated to be retained or protected are injured, and replacement is justified, a number and equivalent diameter inches of trees or shrubs of same or similar species shall be furnished and planted by the Contractor. The total inch diameter of the replacement plant(s) shall equal the diameter of the plant(s) to be replaced, in accordance with the latest edition of the "Guide for Plant Appraisal."

(j) Submittals.

1. Proposed methods and schedule for effectuating tree and other plant protection shall be submitted for approval. Contractor shall submit a construction schedule which includes a time frame for work near existing plants. Approval of such shall be obtained from the City Forester prior to commencement of construction near tree protection areas.
2. Proposed methods, materials, and schedule for root pruning, branch pruning, and other tree maintenance shall be submitted for approval. The City Forester or Project Consulting Arborist shall mark the location of root pruning lines in the field prior to the operation. If possible, root pruning should occur between autumnal leaf fall and spring foliation. Root pruning during the growing season shall require approval of the City Forester or Project Consulting Arborist.

(k) Tree and other Plant Maintenance During and after Completion of Construction.

1. Proper maintenance should include, but without limitation to: structural and remedial pruning; watering; mulching; remediating soil compaction; fertilization; insect and disease control; soil and tissue analysis; aeration; and wound treatment.
2. The timing, duration and frequency of necessary maintenance practices should be determined by the City Forester or Project Consulting Arborist, based on factors associated with the site and affected plants.

Subsection 212.07 is hereby revised to include the following:

Measurement for tree protection shall be by each item and shall include full compensation for the protection of trees in accordance with the drawings and specifications. Payment shall include removal of tree protection devices and any labor, materials or equipment required to restore the site to its original condition.

Subsection 212.08 is hereby revised to include the following:

| Pay Item | Basis of Payment |
|-----------------|-------------------------|
| Tree Protection | Each |

END OF SECTION

**REVISION OF SECTION 212
SEEDING, FERTILIZER, AND SOIL CONDITIONER**

Section 212 of the Standard Specifications is hereby revised for this project as follows:

Subsection 212.02 is hereby revised to include the following:

- a) *Seed*: All seed and seed mixes shall be furnished in bags or containers clearly labeled to show the name and address of the supplier, the common, scientific, and variety name(s) of the seed(s), the lot number, point of origin, net weight, percent of weed content, and the guaranteed percentage of purity and germination. These labels shall be submitted to the project Landscape Architect at the completion of each project.

All materials furnished shall be free of noxious or other invasive weeds including, but not limited to, Russian Knapweed, Diffuse Knapweed, Canada Thistle, Field Bindweed, Johnsongrass, Leafy Spurge, and Kochia. All seed shall conform to all current State and Federal regulations and shall be subject to the testing provisions of the Association of Official Seed Analysis. All seed must be guaranteed for purity and germination, free of noxious weed seed and supplied on a Pure Live Seed (PLS) basis.

b) *Soil Conditioners and Fertilizer*.

1. **Preconstruction Soil Testing**: Engage a qualified testing agency, approved by the Project Manager, to perform preconstruction soil analyses on existing, on-site soil, imported topsoil and pre-amended imported soil.
 - a. Notify Project Manager seventy-two (72) hours in advance of the dates and times when laboratory samples will be taken.
2. **Fertilizer**: Fertilizer (plant nutrients) shall conform to the applicable State fertilizer laws. It shall be uniform in composition, dry, and free flowing, and shall be delivered to the site in the original, unopened containers, each bearing the manufacturer's guaranteed analysis. Fertilizer which becomes caked or damaged will not be accepted.
3. **Soil Conditioner**: Soil conditioner shall consist of compost, biological nutrient, biological culture (Mycorrhiza), or humic acid based material.

Humic acid based material (Humate) shall include the following:

- (a) pH 3 to 5
- (b) Maximum 20 percent inert ingredient
- (c) Minimum 80 percent organic matter with 40 percent minimum humic acid.

Compost shall be weed-free, organic compost derived from a variety of feed stocks including agricultural, biosolids, forestry, food, leaf and yard trimmings, manure, tree wood with no substances toxic to plants. Material shall be aerobically composted in a facility permitted by the Colorado Department of Public Health and Environment (CDPHE) to produce or sell compost in accordance with House Bill (HB) 1181. The Contractor shall submit a copy of this permit to the Engineer for approval and the project records. The compost shall be tested in accordance with the U.S. Composting Council's Test Methods for Examining of Composting and Compost (TMECC) manual.

-2-

**REVISION OF SECTION 212
SEEDING, FERTILIZER, AND SOIL CONDITIONER**

The compost manufacturer shall be a participating member of in the U.S. Composting Council's Seal of Testing Assurance Program (STA). The Contractor shall provide a participation certificate and test data on a Compost Technical Data Sheet.

Compost shall have the following physical properties:

| Compost Parameters | Reported as | Requirements | Test Method |
|--|--|---|--|
| pH | pH units | 6.0 - 8.5 | TMECC 04.11-A |
| Soluble Salts (Electrical Conductivity) | dS m ⁻¹ or mmhos cm ⁻¹ | Maximum 10dS/m | TMECC 04.10-A |
| Moisture Content | %, wet weight basis | 30 - 60% | TMECC 03.09-A |
| Organic Matter Content | %, dry weight basis | 30 - 65% | TMECC 05.07-A |
| Particle Size (Sieve Sizes) | %, dry weight basis for each sieve fraction | <u>Passing</u> 1 inch - 100% ½ inch - 95% | TMECC 02.02-B |
| Man-made Inert Contamination | %, dry weight basis | < 1% | TMECC 03.08-A |
| Stability (Respirometry) | mg CO ₂ -C per g TS per day mg CO ₂ -C per g OM per day | 8 or below | TMECC 05.08-B |
| Select Pathogens | (PASS/FAIL) Limits: Salmonella <3 MPN/4grams of TS, or Coliform Bacteria <1000 MPN/gram | Pass | TMECC 07.01-B Fecal Coliforms, or 07.02 Salmonella |
| Trace Metals | (PASS/FAIL) Limits (mg kg ⁻¹ , dw basis): As 41, Cd 39, Cu 1500, Pb 300, Hg 17, Ni 420, Se 100, Zn 2800 | Pass | TMECC 04.06 |
| Maturity (Bioassay) | | | |
| Percent Emergence | %, (average) | > 80% | TMECC 05.05-A |
| Relative Seedling Vigor | %, (average) | > 80% | |
| The Contractor shall provide a CTR in accordance with subsection 106.13 confirming that the material has been tested in accordance with TMECC. | | | |

-3-

**REVISION OF SECTION 212
SEEDING, FERTILIZER, AND SOIL CONDITIONER**

In general planting areas shall receive Soil Amendments unless otherwise noted or specified by the Project Manager. For bidding, the Contractor shall assume all areas to receive soil amendments will be at four (4) cubic yards per one thousand (1,000) square feet. Once soils tests have been received and determination is made on the proper amount to be added the site-specific soils the rate to be applied may be adjusted per the price based on the Schedule of Values for Soil Amendment.

For planting areas a soil fertility and texture test conducted by the Colorado State University Soils Lab or other approved certified lab shall be completed and submitted to the project Landscape Architect for review. Lab reports shall contain recommendations for soil amendments and fertilizer. Lab reports shall contain recommendations for soil amendments and fertilizer. Recommendations in the lab reports shall be followed in all cases unless directed otherwise by the project Landscape Architect. Soil tests shall be performed on existing, on-site soil, imported topsoil, and pre-amended topsoil.

Recommendations: Based on the test results, state recommendations for soil treatments, soil amendments, and soil conditioners to be incorporated to produce satisfactory planting soil suitable for healthy, viable plants indicated in the contract documents. Include, at a minimum, recommendations for nitrogen, phosphorous, and potassium fertilization, and for micronutrients.

Fertilizers and Soil Amendment Rates: State recommendations in weight per one thousand (1,000) sq. ft. for six-inch (6") depth of soil.

***Generally, adjust soil reaction (pH) only in soils where the pH is near the extreme ends of the acceptable range for the plants indicated. ***

Soil Reaction: State the recommended liming rates for raising pH or sulfur for lowering pH according to the buffered acidity or buffered alkalinity in weight per one thousand (1,000) sq. ft. for six-inch (6") depth of soil.

Sample collection and labeling:

Number and Location of Samples: Minimum of five (5) samples per acre collected randomly throughout the areas to receive similar soil preparation, including seed/sod, native seeding, planting beds, and gardens. Provide a map to the Project Manager of sampling locations prior to sampling for approval.

Procedures and Depth of Samples: Collect samples to a depth of six inches (6") and combine in a clean plastic container.

Mixing of Samples: Mix samples together thoroughly, removing plant debris and breaking up clods.

Labeling: Label each sample with the date, location keyed to a site plan or other location system, visible soil condition, and sampling depth.

Subsection 212.06 (a) is hereby revised to include the following:

Thoroughly till or rip all areas which are to be planted to a depth of twelve (12) inches. The soils shall be worked until no clods greater than two (2) inches in diameter remain, unless directed otherwise by Project Landscape Architect. Remove rocks and other objects three (1) inches or greater in any dimension.

Proceed with application and installation only after unsatisfactory conditions have been corrected and approved by the Project Manager.

-4-

**REVISION OF SECTION 212
SEEDING, FERTILIZER, AND SOIL CONDITIONER**

Beginning of application and installation means Acceptance of existing conditions by the Contractor.

Soil Preparation in Planting Areas. Apply Soil Amendments at the following rates:

Soil Amendments: Bid quantity to be four (4) cubic yards per one thousand (1,000) square feet, or per soil test recommendations.

Fertilizer: Refer to Related Sections. Mycorrhizal inoculants: Apply per manufacturer's instructions and quantities appropriate to the planting type.

After applying Soil Amendments, thoroughly till area to depth of six inches (6") minimum by plowing, rototilling, harrowing, or disking until soil is well pulverized and thoroughly mixed. Soil Conditioners and Fertilizer shall be applied topically once final grade has been established and just prior to planting.

Take soil samples, in similar locations to pre-construction testing, and test amended soil to ensure the final product meets the laboratory recommendations prior to planting.

Complete fine grading for all areas prior to seeding or planting. Allow for natural settlement.

For ground surface areas surrounding buildings to be landscaped, maintain required positive drainage away from buildings.

Establish finish grades as follows:

Unpaved Planting Areas: Finish areas to within not more than +/- five one-hundredths (.05') of a foot above or below required elevations.

Water Quality Planters: Finish areas to within not more than +/- five one-hundredths (.05') of a foot above or below elevations indicated on Construction Documents.

Finish grade shall be below edge of pavement prior to planting.

Planting Beds: Allow four inches (4") for mulch.

Compaction of Surface Grade Prior to Landscape Installation: Firm, but not hard, eighty five percent (85%) standard Proctor density within two percent (2%) optimum moisture.

Restore planting areas to specified condition if eroded or otherwise disturbed after fine grading and prior to planting.

Contractor shall be responsible for coordinating soil preparation inspections with Denver Water, call (303) 628-6682 at least seventy-two (72) hours prior to installing sod, seed or plantings.

-5-

**REVISION OF SECTION 212
SEEDING, FERTILIZER, AND SOIL CONDITIONER**

Subsection 212.06 (b) is hereby revised to include the following:

Fertilizing and Soil Conditioning. Prior to planting, fertilizer, soil conditioner, or both shall be applied. The fertilizer and soil conditioner type and rate of application shall be as designated in the Contract. Fertilizer called for on the plans shall be worked into the top 4 inches of soil at the rate specified in the contract. Biological nutrient, culture or humic acid based material called for on the plans shall be applied in a uniform application onto the soil service. Organic amendments shall be applied uniformly over the soil surface and incorporated into the top 6 inches of soil. No measurable quantity of organic amendment shall be present on the surface after incorporation.

Subsection 212.06 (c) is hereby revised as follows:

Provide notice to the Project Manager requesting inspection at least seventy-two (72) hours prior to anticipated date of the work.

Deficiencies: The Project Manager will specify deficiencies to the Contractor who shall make satisfactory adjustments and shall again notify the Project Manager for an additional inspection.

Protect areas adjacent to soil preparation and planting areas from contamination. Keep adjacent paving and construction clean and work area in an orderly condition.

Remove debris and excess materials from site. Clean out drainage inlet structures. Clean all paved and finished surfaces that are soiled as a result of work under this Section

Provide and install barriers as required and as directed by the Project Manager to protect completed areas against damage from pedestrian and vehicular traffic until Acceptance by the City.

Protect areas of in-place soil from additional compaction, disturbance, and contamination. Prohibit the following practices within these areas except as required to perform planting operations:

- Storage of construction materials, debris, or excavated material.
- Parking vehicles or equipment.
- Vehicle traffic.
- Foot traffic.
- Erection of sheds or structures.
- Impoundment of water.
- Excavation or other digging unless otherwise indicated.

If prepared soil or subgrade is disturbed or contaminated prior to planting, the Contractor shall restore or replace the planting soil as directed by the Project Manager at no cost to the City

Subsection 212.08 shall include the following:

Seeding, fertilizing and soil conditioning shall not be measured and paid for separately but shall be included in the planting items.

END OF SECTION

**REVISION OF SECTION 212
LANDSCAPE RESTORATION**

Section 212 of the Standard Specifications is hereby revised for the project as follows:

The following shall be included in Section 212.01:

Areas designated on the plans for Landscape Restoration shall include fine grading, minor sodding, and modification of irrigation systems to allow for the construction of project improvements.

Section 212.05 shall include the following:

- (d) Landscape restoration as noted on the plans shall include the grading for placement of sod to cover disturbed areas and restore the lawn area adjacent to the new improvements. Contractor shall select a sod type to match existing and provide a sample to the engineer for approval prior to ordering.

This item shall also include making modifications or relocations to sprinkler heads and irrigation lines to provide irrigation coverage of all sod areas. Sprinklers shall be adjusted to not irrigate the hard project improvements.

Restoration of Landscape in the Speer Median shall be completed in accordance with Denver Parks and Recreation Department standards and specifications.

The following shall be included in Section 212.07:

Elements for Landscape Restoration will not be measured and paid for separately but shall be paid for as a Lump Sum item to include all work described herein, including materials and labor needed to restore the landscape areas adjacent to the project improvements.

The following shall be included in Section 212.08:

| Pay Item | Pay Unit |
|-----------------------|-----------------|
| Landscape Restoration | Lump Sum |

END OF SECTION

**REVISION OF SECTION 213
MULCHING
DESCRIPTION**

Section 213 of the Standard Specifications is hereby revised for this project as follows:

Subsection 213.01 shall include the following:

213.01 This work consists of furnishing and placing shredded wood mulch in the planting beds in accordance with the details shown on the plans.

MATERIALS

Subsection 213.02(d) shall include the following:

Wood chip mulch shall be shredded Western Red Cedar (Gorilla Hair Mulch). Contractor shall submit a 0.5 cubic foot sample for approval prior to ordering.

Subsection 213.02 shall include the following:

Pesticides:

- a. Pesticide registered with the EPA, acceptable to authorities having jurisdiction and type recommended by manufacturer for specific problem and as required for project conditions.
- b. Pre Emergent herbicide for controlling the germination and growth of weeds within aggregate surface areas at the base course level of the aggregate layer.

Subsection 213.03(e) is hereby revised as follows:

(e) Shredded Wood Mulch. A 3-inch layer, unless otherwise shown in the plans, of wood chip mulch shall be uniformly applied to all planting beds as shown on the plans or as directed. Wood chip mulch shall be placed in all planting beds and SSP's. Wood chip mulch shall be capable of matting together to resist scattering by the wind. Do not place mulch against stems of plants and keep four inches (4") away from tree trunk.

Install pesticides prior to woodchip mulch installation.

Subsection 213.05 shall include the following:

| Pay Item | Pay Unit |
|-----------------|-----------------|
| Wood Mulch | Cubic Foot |

END OF SECTION

**REVISION OF SECTION 214
PLANTING**

Section 214 of the Standard Specifications is hereby revised for this project as follows:

214.01 This work consists of furnishing and planting trees, shrubs, perennials, and other plant material, hereinafter referred to as “plants” and as shown on the plans or as directed.

MATERIALS

214.02 General. Plants shall be of the species or variety designated in the Contract, in healthy condition with normal well developed branch and root systems, and shall conform to the requirements of the current American Standard for Nursery Stock. The Contractor shall obtain certificates of inspection of plant materials that are required by Federal, State, or local laws, and submit the certificates to the Engineer.

All plants shall be free from plant diseases and insect pests. All shipments of plants shall comply with all nursery inspection and plant quarantine regulations of the State of origin and destination, and the Federal regulations governing Interstate movement of nursery stock.

The minimum acceptable sizes of all plants, with branches in normal position, shall conform to the measurements specified in the Contract.

Plants hardy in hardiness zones 2, 3, 4, and 5 only will be accepted. Hardiness zones are defined in U.S. Department of Agriculture publications.

All container grown plants shall be those plants that have been growing in a nursery for at least one growing season, or plants that have established themselves in accordance with definitions set forth in the Colorado Nursery Act, Title 35, Article 26, CRS.

- 1) *Trees:* Nursery stock shall be harvested and planted during the same growing season. Do not prune, except as approved by the City Forester and Project Landscape Architect. Protect bark, branches, and root systems from sun scald, drying, sweating, whipping, and other handling and tying damage. Do not bend or tie trees in such a manner as to destroy natural shape. Provide protective covering during delivery. Plant materials delivered without protective covering may be rejected. Do not drop trees during delivery. All trees shall be labeled with a securely attached waterproof tag bearing a legible plant name. Remove all tags and flagging as directed by the Project Landscape Architect.

Apply antidesiccant to trees and shrubs using power spray to provide an adequate film over trunks (before wrapping), branches, stems, twigs, and foliage to protect during digging, handling, and transportation.

- a. If deciduous trees or shrubs are moved in full leaf, spray with antidesiccant at nursery before moving and again (2) two weeks after planting.

Handle planting stock by the root ball only.

Deliver trees after preparations for planting have been completed and install immediately. If planting is delayed more than six (6) hours after delivery, set planting materials in shade, protect from weather and mechanical damage, and keep roots moist.

- a. Set balled stock on ground and cover ball with wood chips, or other acceptable material.
- b. Do not remove container-grown stock from containers before planting.
- c. Water root systems of trees stored on site with a fine-mist spray. Water as often as necessary to maintain root systems in a moist condition

-2-
**REVISION OF SECTION 214
 PLANTING**

Trees and shrubs shall have been root-pruned during their growing period in the nursery in accordance with standard nursery practice.

If plants of acceptable quality and specified variety or size are not available locally, the Contractor may:

- (1) Substitute acceptable plants that are larger than specified at no change in contract price.
- (2) On written approval, substitute smaller plants than those specified in the Contract at the adjusted price stated in the written approval.
- (3) On written approval, substitute plants of a different genus, species, or variety at the adjusted price stated in the written approval.

Before any substitution of plants will be considered, the Contractor shall furnish to the Project Landscape Architect written statements from three sources verifying that the plants designated on the plans are not available.

At the landscape pre-construction conference, the Contractor shall name the nursery stock supplier for all items. The Contractor shall tag all nursery stock for inspection by the Engineer. The Engineer will reject any nursery stock not meeting the Contract at any of the three following times and locations:

- (1) At the named supplier's location. The Engineer will notify the Contractor when nursery stock will be inspected at the supplier's location.
- (2) On the project site at the time of delivery, prior to planting.
- (3) At the time of installation. Final acceptance of all plant material will be made at the time of installation on the project site.

Deciduous plants, broadleaf evergreens, and conifers shall be balled and burlapped, or in containers used in standard nursery practice. Balling and burlapping shall conform to the recommended specifications in the American Standard for Nursery Stock. The ball of the plant shall be natural, not made, and the plant shall be handled by the ball at all times. No balled and burlapped plant shall be accepted if the ball is broken or the trunk is loose in the ball.

Each species shall be identified by means of grower's label affixed to the plant. The grower's label shall include the data necessary to indicate conformance to specifications.

Plants for fall planting shall be furnished balled and burlapped or container-grown unless otherwise designated in the Contract or approved.

- (a) At-Grade Planter Stakes. Wood stakes shall be 2 inches x 2 inches square, or 2 ½ inch diameter and 6 feet long free from bends. Metal stakes shall be 6 feet long standard T-bar steel fence post. Wood stakes shall be made of untreated wood guaranteed to last in the ground at least two growing seasons. The bottom of wood stakes shall be pointed. All staked material shall include fabric guys at plant material contact points made specifically for guying purposes. Fabric or plastic flags, measuring 1' X 1' shall be affixed to wire guys located a minimum of 2' above finished grade and maintained until the staking systems are removed.

-3-
**REVISION OF SECTION 214
 PLANTING**

- (b) *Planter Stakes Trunk Stabilization by Underground Guying (Subsurface Anchoring System (Plati -Mat):* Install tree stabilization as follows unless otherwise indicated on Contract Drawings.
- 1) Underground tree anchoring system: Use Platipus brand Plati-Mat (RF1P model) rootball anchoring system.
 - a. Drive earth anchor into undisturbed grade below tree pit in a triangular pattern. Avoid penetrating root balls or root masses.
 - b. Pull on earth anchor cable to securely load lock the anchor.
 - c. Lay Plati-Mat protection mat in triangular pattern across rootball surface.
 - d. Thread tensioning cable through the three earth anchor cables and tighten with tensioning device.
 - e. Backfill with designated soil mixture per Contract Drawings.
- (c) Soil Conditioners and Fertilizer. Soil conditioner shall consist of composted plant material, 90 percent ¼ inch or less with a carbon to nitrogen ratio of 15:1 to 25:1. A sample of the soil conditioner and certificate of compliance shall be provided to the Engineer to verify the organic matter content, and carbon matter to nitrogen ratio shall be submitted one month prior to planting for approval.
- Fertilizer for planting shall be used as specified in the Contract.

CONSTRUCTION REQUIREMENTS

- 214.03 General.** All plants shall be protected from drying out or other injury. Broken and damaged roots shall be pruned before planting.
- (a) **Planting Seasons.** Plants shall be planted in accordance with the Contract, generally from Spring thaw to June 15th and again starting August 15th until October 1st.
- Areas to be planted shall be brought to the lines and grades designated or approved. The location of plants shown in the Contract is approximate to the degree that unsuitable planting locations shall be avoided. Trees shall be planted at least 30 feet from the edge of the traveled way, except when guardrail or vertical curb exists, this distance may be reduced to 20 feet. Locations and layouts shall be approved before preparatory work for planting is started. Shrubs shall not be planted closer than 6 feet from the edge of pavement.
- All layout staking for planting shall be done by the Contractor and shall be approved by the Engineer before planting holes are prepared.
- The Contractor shall place all plant material according to the approved planting plans, or as directed.
- (b) **Excavation.** Planting pits shall be circular in outline with vertical or sloped sides. Pits for trees and shrubs shall be at least two times greater in diameter than the earth ball.
- (c) **Planting.** Planting shall be done in accordance with good horticultural practices. Plants of upright growth shall be set plumb and plants of prostrate type shall be set normal to the ground surface. Plants with dry, broken, or crumbling roots will not be accepted for planting.

-4-
**REVISION OF SECTION 214
 PLANTING**

Planting pits shall be dug 2 to 4 inches shallower than the height of the rootball for trees, and 2 inches shallower for shrubs. The tree rootball shall be set in the center of the planting pit on undisturbed soil. Trees shall be stabilized and then the wire basket, any twine or wire, and burlap shall be removed before the pit is backfilled. Shrubs shall be planted in the center of the pit. Plastic, metal, fabric, or peat containers shall be removed. Shallow scores ¼ to ½ inch deep shall be made along the edges of the rootball.

Areas to be planted with ground cover shall be prepared by placing topsoil and a ½ inch layer of soil conditioner on the ground surface, and roto-tilling to a depth of 6 inches. Ground cover shall be planted by excavating to a depth sufficient to accommodate the root structure of plant materials without crimping or bending roots. After planting, backfill shall be placed around the ground cover and compacted firmly around the roots. The planted areas shall be brought to a smooth and uniform grade, and then top dressed with a 2 inch mulch cover of the type specified on the plans.

- (d) Backfilling. When soil conditioner is specified, composted plant material shall be added and thoroughly mixed into the backfill material at the rate of 0.5 cubic foot per tree and 0.1 cubic foot per shrub.

Backfill shall be thoroughly worked and watered-in to eliminate air pockets.

Watering shall be done immediately after the plant is placed. Backfilling of the planting pit shall be resumed after this water is absorbed. Roots and crown shall be covered with soil at this time. After the soil has settled, plants must be in the proper position and at the proper depth. Saucers shall be prepared around each plant to the dimensions shown on the planting details. When saucers are required they shall be covered with a 4 inch thick layer of fresh moist shredded wood mulch conforming to Section 213. After completion of all planting and before acceptance of the work, the Contractor shall water plants installed under this Contract, as needed to maintain a moist root zone optimum for plant growth. Plants damaged by the Contractor's operations shall be replaced at the Contractor's expense.

Surplus soil remaining after backfilling is completed shall be removed from the site and disposed of per local regulations.

- (e) Pruning. All deciduous trees and shrubs shall be pruned in accordance with standard horticultural practice, preserving the natural character of the plant. Guidelines for pruning are indicated in the planting details. Pruning cuts shall be made with sharp clean tools.

All clippings shall become the property of the Contractor and be removed from the site.

- (f) Staking. All deciduous trees 2 inch caliper and greater shall be staked with two stakes. Stakes shall conform to subsection 214.02(c). Stakes shall be driven 2 feet into the ground with one stake on the side of the prevailing wind (generally the west side) and the other stake on the opposite side. Stakes shall be driven at least 1 foot outside each edge of the planting pit. Trees shall be guyed with 1 to 2 inch wide strips of nylon webbing with metal grommets.

Stakes shall be placed parallel to the street in order to minimize conflict with pedestrians.

Trees specified to be guyed with wire shall be secured with No. 12 gage annealed galvanized steel wire free of bends and kinks.

- (g) Wrapping Materials. Wrapping material shall be horticulturally approved waterproof wrapping paper. Wrapping shall be applied from the base of the tree upward to the second scaffold branch and secured with arbor tape. Populus sp. are exempt from tree wrap. The Contractor shall submit the manufacturer's certification for the wrapping material requirements.

-5-
**REVISION OF SECTION 214
 PLANTING**

Wrapping shall be done in the fall months prior to freeze, and removed in the spring. Wrapping shall not remain on any trees throughout the summer months. Wrapping shall be removed by the Contractor.

All plant tags shall be removed from plants and all packing or other material used by the Contractor shall be removed from the site.

- (h) Irrigation. Plantings that are to be irrigated shall be planted so that the irrigation system is operating and supplying the designated amount of water as planting is occurring. Plants shall be watered within 15 minutes of planting.

214.04 Landscape Establishment. From the time of installation, during construction, and throughout the Landscape Establishment period the Contractor shall maintain all plant material and seeded areas in a healthy and vigorous growing condition, and ensure the successful establishment of vegetation. This includes performing establishment, replacement work, and landscape maintenance work as described below.

The beginning of the Landscape Establishment period depends upon receipt of the written Notice of Substantial Landscape Completion from the Engineer.

Substantial Landscape Completion occurs when all plant materials in the Contract have been planted and all work under Sections 212, 213, 214 and 623 has been performed, except for the Section 214 pay item, Landscape Maintenance. If the Notice of Substantial Landscape Completion is issued during the spring planting season, the Landscape Establishment period begins immediately and lasts for a period of 12 months. If the Notice of Substantial Landscape Completion is issued at any other time, the Landscape Establishment period begins at the start of the next spring planting season and lasts for a period of 12 months.

- (a) Establishment and Replacement. After all planting on the project is complete, a plant inspection shall be held including the Contractor, Engineer and Project Landscape Architect to determine acceptability of plant material. During the inspection, an inventory of rejected material will be made, and corrective and necessary cleanup measures will be determined.

Dead, dying, or rejected material shall be removed each month during the Landscape Establishment period as directed. Plant replacement shall be performed during the spring planting seasons at the beginning and end of the Landscape Establishment Period. Plant replacement stock shall be planted in accordance with the Contract and is subject to all requirements specified for the original material. Plant replacement shall be at the Contractor's expense.

- (b) Landscape Maintenance. During the Landscape Establishment period the Contractor shall perform landscape maintenance as described herein. The Contractor shall maintain all landscaped areas in the condition they were in when first installed and accepted.

Prior to the Notice of Substantial Landscape Completion, the Contractor shall submit a detailed maintenance plan which includes a schedule showing the number of hours or days personnel will be present, the type of work to be performed, supervision, equipment and supplies to be used, emergency program and responsible person to contact for emergency work, and inspection schedule. The detailed maintenance plan is subject to review and approval by the Engineer. The Engineer will not issue the Notice of Substantial Completion until the Engineer has received and approved the maintenance plan.

The proposed types, brand names, material safety data sheets, and rates of application of herbicides, pesticides, and fertilizers to be used shall be submitted for approval with the detailed maintenance plan. Herbicides, pesticides, and fertilizers shall meet all local, state, and federal regulations and shall be applied by a licensed applicator.

-6-
**REVISION OF SECTION 214
 PLANTING**

The Contractor shall perform start-up, watering, programming, operation, and fall winterization of the irrigation system. The Contractor shall do a spring start-up of the irrigation system prior to Final Acceptance and perform all irrigation system warranty work as specified in Section 623.

The Contractor shall keep a project diary documenting all landscape and irrigation maintenance activities including work locations and time spent. The Contractor shall provide copies of the diary to the Engineer upon request.

The Contractor shall restore and reseed eroded areas and areas of poor establishment in accordance with Sections 212 and 213. The Contractor shall maintain staking and guying until the end of the Landscape Establishment period. The Contractor shall remove all guying wire, straps, and stakes at the end of the Landscape Establishment period.

During the landscape establishment period, the Contractor shall water, cultivate, and prune the plants and repair, replace, or readjust guy material, stakes, and posts as required or directed by the Engineer. The Contractor shall reshape plant saucers, repair washouts and gullies, replace lost wood chip mulch, keep all planting sites free from weeds and do other work necessary to maintain the plants in a healthy and vigorous growing condition. This includes seasonal spraying or deep root watering with approved insecticides or fungicides as required.

1. Watering in Irrigated Areas. Trees planted at all locations on the project shall be watered once per month at the rate of 30 gallons per tree for the months November through April until the Landscape Establishment period ends.

Shrubs planted at all locations on the project shall be watered once per month at the rate of 10 gallons per shrub for the months November through April until the Landscape Establishment period ends.

The contract performance bond, required by subsection 103.03, shall guarantee replacement work during the plant establishment period.

If all other work is completed on a project, no contract time will be charged during the plant establishment period.

Subsection 214.03(g) is hereby revised to include the following:

Tree Wrapping Materials. Wrap tree trunks with tree wrap and secure with tape. Tree wrap tape shall be two layers of crinkled paper cemented together with bituminous material, four-inches (4") wide minimum, with stretch factor of thirty-three percent (33%). Start at base of trunk and spiral cover trunk to height of first branches. Overlap wrap, exposing half the width, and securely attach without causing girdling. Use tape as approved by the City Forester and or the Project Manager to secure. Do not use staples. Inspect tree trunks for injury, improper pruning, and insect infestation and take corrective measures required before wrapping.

- 1) All deciduous trees shall be wrapped between November 1st and November 15th or per the direction of the City Forester and or the Project Manager. All tree wrap shall be removed by May 15.
- 2) Contractor shall be responsible for wrapping and unwrapping trees during the warranty period.

Subsection 214.04 is hereby revised to include the following:

Contractor shall maintain the landscape improvements through the 12 month warranty period until Final Acceptance is granted for the project.

-7-
**REVISION OF SECTION 214
 PLANTING**

METHOD OF MEASUREMENT

214.05 The quantity of planting to be measured will be the number of plants, of the types and sizes designated in the Contract that are actually planted and accepted.

Landscape Maintenance will not be measured but will be paid for on a lump sum basis.

BASIS OF PAYMENT

214.06 The accepted quantities of planting, and brush layer cuttings will be paid for at the contract unit price for each of the various items listed below that appear in the bid schedule.

Payment for the total cost of the item will be made at the completion of planting. Cost of the performance bond shall be included in the cost of the plant items.

Payment will be made under:

| Pay Item | Pay Unit |
|--------------------------------------|-----------------|
| Deciduous Tree (3Inch Caliper) | Each |
| Deciduous Shrub (2 Gallon Container) | Each |
| Deciduous Shrub (5 Gallon Container) | Each |
| Perennials (1 Gallon Container) | Each |
| 1 Year Landscape Maintenance | Lump Sum |

Water required for all items of work will not be measured and paid for separately, but shall be included in the work.

Payment shall be full compensation for all work necessary to complete the item.

For each month that landscape maintenance is performed and accepted during the Landscape Maintenance period as specified in subsection 214.04, payment for Landscape maintenance will be made in installments as follows:

- (1) 10 percent of the lump sum amount will be paid for each of the eight growing season months, March through October.
- (2) 5 percent of the lump sum amount will be paid for each of the winter months, November through February.

Landscape maintenance performed during construction will not be measured and paid for separately, but shall be included in the work.

Landscape Establishment, except for landscape maintenance, will not be paid for separately, but shall be included in the work.

END OF SECTION

**REVISION OF SECTION 250
ENVIRONMENTAL HEALTH AND SAFETY MANAGEMENT**

Section 250 of the Standard Specifications is hereby appended to for this project as follows:

Subsection 250.03 shall include the following:

- (e) References: The following reports are made part of this project. The Contractor is instructed to become familiar with the provisions of these documents, which are part of the design specifications:
1. "City and County of Denver Standard Materials Management Plan." Prepared by the Denver Department of Public Health and Environment, Environmental Quality Division, dated November 13, 2019.
 2. "Regulated Asbestos Contaminated Soil Standard Operation Procedure." Prepared by the Denver Department of Public Health and Environment, Environmental Quality Division, dated May 24, 2019.
 3. "Clarification on Guidance for Reuse of Soil on City Projects." Prepared by the Denver Department of Public Health and Environment, Environmental Quality Division, dated May 8, 2019.
 4. "Pre-Dig Checklist For Contractors"
 5. "Limited Environmental Screening, Larimer Street over Cherry Creek Bridge Replacement Project, Denver, Colorado." Prepared by Pinyon Environmental, Inc., dated May 17, 2022 – Under Separate Cover
- (f) Additional Requirements and Information
- The Contractor shall identify a point of contact responsible for compliance with environmental provisions. The point of contact may be the Materials Management Plan (MMP) Supervisor, Health and Safety Officer, project Supervisor, or another responsible person. The environmental point of contact must have the appropriate training to understand this Specification, as well as the various documents as described herein and appended to the specifications. The environmental point of contact will be responsible for coordinating compliance with those portions of the Contract and Specifications that have impacts on environmental and/or permit compliance, as well as local, state, and federal environmental regulations. The Contractor should expect that this person will coordinate with the Engineer as necessary regarding compliance.
 - Workers shall be alert during excavation for any visual or olfactory signs of impacts. If impacted soil and/or groundwater is encountered, work will stop immediately, and the procedures outlined in the CDOT Specification Section 250, this revision to Section 250, and subsection 107.25.8 shall be followed.
 - Environmental investigations have been completed in the vicinity of the project area with results being below regulatory screening values (Environmental Protection Agency [EPA] Regional Screening Levels [RSLs]); however, historical grading and channelization near Cherry Creek indicates that potential solid wastes may be discovered unexpectedly during the work.
 - Asbestos-Containing Material has been identified with a white sealant on the bridge railings; this material must be properly abated prior to bridge demolition.

-2-

**REVISION OF SECTION 250
ENVIRONMENTAL HEALTH AND SAFETY MANAGEMENT**

- Procedures for the management of Regulated Asbestos-contaminated Soil (RACS) are included in the City and County of Denver Regulated-Asbestos Contaminated Soil Standard Operating Procedure (RACS SOP), appended to the Specifications.
- The Contractor shall be responsible for the required workers' health and safety; providing a Health and Safety Officer (HSO), MMP Supervisor, and Certified Asbestos Building Inspector (CABI); conducting sampling & testing (if necessary); and the handling of regulated materials according to the MMP, RACS SOP, and applicable local, state, and federal regulations.
- All personnel that will be conducting any subsurface work/earth disturbing activities will be required to complete a 15-minute training video and pass the exam on RACS. The Contractor and all personnel (doing earth work) shall maintain the certification records and will submit to the City Project Manager a valid certification upon demand. The certification will need to be renewed every two (2) years. The training video can be accessed at: <https://www.denvergov.org/content/denvergov/en/environmental-health/our-divisions/environmental-quality/land-use-and-planning/racs.html>
- The Contractor shall complete and submit to the City Project Manager the Pre-Dig Checklist for Contractors found in the Appendix, prior to starting soil disturbing activities.

Environmental Health and Safety Management

- The Contractor will prepare a project Health and Safety Plan and submit an electronic copy of the plan to the Engineer.
- The Contractor may share its Health and Safety Plan with its subcontractors or require each subcontractor to prepare his own plan.
- The Contractor shall hold an environmental coordination meeting with Engineer and DDPHE a minimum of 15 days prior to the start of excavation to review the Contractor's Project Health and Safety Plan and procedures that the Contractor will deploy to implement the MMP, RACS SOP, and other environmental topics and permits as applicable.
- Workers and managers associated with intrusive activities will be required to undergo a one-time health and safety orientation meeting at the start of the Project, to include a brief on-site description of Project area conditions. This meeting must include two-hour asbestos awareness training conducted by a trained asbestos professional such as a Certified Asbestos Building Inspector. If Project personnel change for any reason during Project work (i.e., additional or replacement personnel), additional asbestos awareness trainings are required.
- All associated work related to *Environmental Health and Safety Management* will be not be measured separately but will be paid for on a lump-sum basis.

-3-

**REVISION OF SECTION 250
ENVIRONMENTAL HEALTH AND SAFETY MANAGEMENT**

Health and Safety Officer

The Contractor will assign a health and safety officer (HSO) to provide project support in accordance with the requirements in the MMP. The HSO will meet the definition of an HSO as described in CDOT's Specification 250, including, but not limited to: "having at least two years of field experience in chemical related health and safety. The HSO shall be either a Certified Industrial Hygienist, Certified Hazardous Material Manager, Professional Engineer, Certified Safety Professional, or Registered Environmental Manager meeting the criteria set forth in 29 CFR 1926." The HSO will be paid under the pay item "Health and Safety Officer" and will be measured on an hourly basis.

MMP Supervisor

Prior to implementation of the MMP, the awarded Contractor will retain an MMP Supervisor (referred to in the referenced MMP as an 'Environmental Professional') to independently verify that the requirements of MMP are followed in a Quality Assurance (QA) role. The MMP Supervisor must be a competent individual with at least two years of experience in the field-identification of suspect regulated materials and potential environmental hazards (e.g., abandoned underground storage tanks, asbestos, uncontrolled fill), as well as appropriate characterization, management, and disposal methods for impacted materials. The MMP Supervisor will have a minimum training requirement of 40-Hour Occupational Safety and Health Administration (OSHA) Hazardous Waste Operations Training and current 8-hour OSHA annual update. Ideally, the MMP Supervisor will also meet the requirements of a Certified Asbestos Building Inspector, as described in the MMP and below, and fill both roles concurrently to provide project efficiencies. The MMP Supervisor is not required to be on-site on a full-time basis but should be available to quickly mobilize to the work site in the event the Contractor identifies suspicious materials, such as stained or odorous soil or soil containing debris, trash, suspected asbestos, etc. Costs should include all associated expenses to carry out the work.

The MMP Supervisor will be paid under the pay item "MMP Supervisor" and will be measured on an hourly basis.

Certified Asbestos Building Inspector (CABI) Support

The Contractor shall provide a CABI who will be required to be on site during soil-disturbing activities if buried debris, solid wastes, or other suspicious materials that could be associated with asbestos are encountered. The CABI shall meet the training requirements of Section 5.5.3(D) of the Colorado Solid Waste Regulations. The CABI must be employed independently of the Contractor (i.e., the CABI cannot be an employee of the Contractor). The CABI will also be trained and certified in accordance with Air Quality Control Commission Regulation No. 8 (5 CCR 1001-10, Part B), for the identification of asbestos-containing materials and the collection of samples to evaluate asbestos content. The CABI must have worked on at least three different asbestos-in-soil projects and with a minimum of 40 hours of experience as a CABI.

-4-

**REVISION OF SECTION 250
ENVIRONMENTAL HEALTH AND SAFETY MANAGEMENT**

The CABI must have sufficient experience to identify historical urban fill and RACS in the field. Depending on the project schedule, a minimum of one CABI will be overseeing excavation work, and it may be necessary to engage multiple CABIs if areas of known historical fill or debris are identified at multiple excavation areas. The basis of payment for the CABI is on an hourly basis. The Contractor should expect that the CABI will be on site 100% of the time during soil-disturbing activities should suspect materials, debris, construction and demolition debris, HUF, or other suspected materials are encountered. When the Contractor is working in “clean” soil – that is, soil that does not contain debris, the CABI is not required to be present. See the RACS SOP for detailed information regarding the CABI’s responsibilities. Costs should include all associated expenses to carry out the work.

The Contractor is permitted (and encouraged) to retain a CABI that can fill the role of the MMP Supervisor concurrently, as this would be a cost-saving measure.

The CABI will be paid under the pay item “Certified Asbestos Building Inspector” and will be measured on an hourly basis.

Asbestos and Chemistry Analytical Costs

If required, to evaluate chemical characteristics in soil and/or groundwater samples, or asbestos content in suspect materials, soil and/or suspect material samples shall be analyzed by a NELAC- (or equivalent) certified laboratory. The Contractor should include costs for up to 5 chemical samples, and 20 asbestos samples.

Analytical costs will be paid for under the “Material Sampling and Delivery – Chemical” and Material Sampling and Delivery – Asbestos” and will be measured by each unit based on quoted laboratory rates for the required analysis.

Solid Waste Excavation, Loading, and Transportation

Materials as described in the MMP that are not considered hazardous waste, may be transported and disposed as non-hazardous solid waste to the Denver-Arapahoe Disposal Site. Tipping fees associated with disposal at the Denver-Arapahoe Disposal Site will be paid for separately by the Owner. The Owner will work to establish a Waste Profile and will supply the Contractor with Waste Manifests that must accompany each load destined to DADS.

Solid waste excavation, loading, and transportation will be paid for under the pay item “Solid Waste Excavation, Loading, and Transportation” and will be measured by on a cubic-yard basis and shall include providing any additional soil required above the excess material generated by the project.

-5-

**REVISION OF SECTION 250
ENVIRONMENTAL HEALTH AND SAFETY MANAGEMENT**

Lead-based Paint

Per Executive Order No. 123, Chapter 5, the Contractor shall recycle construction and demolition when possible. Contractor shall provide proof of any recycling of materials. All metal project components (e.g., light poles, metal railing, and bridge girders) removed for this project shall be recycled. The recycling facility must be notified that metal project components could contain lead. The Contractor should treat painted components as lead-containing or lead-based until laboratory sampling confirms otherwise. Regardless of lead content, the future Contractor must comply with Occupational Safety and Health Administration (OSHA) Regulation 1926.62 for worker safety. OSHA regulations do not define a minimum concentration of lead as a threshold for action. The potential for lead-containing or lead-based paint and regulatory requirements are hereby disclosed to the Contractor so that the Contractor may avoid accidental disturbance or worker exposure, and for the Contractor to follow applicable regulations. The Contractor shall avoid sanding, cutting, burning, or otherwise causing the release of lead from paint.

Costs for managing metal project components covered with lead paint shall not be paid for separately but shall be included in the cost of the work.

Asbestos-Containing Material Abatement

As discussed in the “Limited Environmental Screening, Larimer Street over Cherry Creek Bridge Replacement Project, Denver, Colorado,” prepared by Pinyon Environmental, Inc., dated May 17, 2022, friable asbestos-containing material has been identified on the bridge, associated with a white sealant on the bridge railings. Before demolition may begin, this material must be abated in accordance with Colorado Department of Public Health and Environment Air Quality Control Commission Regulation No. 8 (5 CCR 1001-10, Part B). The Contractor shall provide a lump sum bid to conduct all removal/abatement of asbestos-containing materials associated with the bridge structure, including associated permits, clearances, disposal, etc., necessary to demolish the bridge in accordance the applicable local, state, and federal regulations. Ultimately, a CABI must clear the bridge for demolition, and the Contractor must secure a demolition permit from the CDPHE.

Environmental Allowance Account

The following items, if needed, will be paid for from the Environmental Allowance Account:

Air Monitoring Specialist:

An Air Monitoring Specialist, who is also a CABI as described above, must oversee the RACS management, in accordance with the RACS SOP. The Contractor should expect that the Air Monitoring Specialist will be on site 100% of the time during RACS Excavation and Loading activities (i.e., excavation and loading of 1% of solid waste, as described below). Costs would include all associated labor and expenses to carry out the work, as described in the RACS SOP, including samples, field equipment, instrumentation, etc.

-6-

**REVISION OF SECTION 250
ENVIRONMENTAL HEALTH AND SAFETY MANAGEMENT**

RACS Excavation, Loading, and Transportation:

Once RACS have been confirmed, and management required, all costs, including those related to excavation and loading and transportation, shall be included with this pay item. This includes, but is not limited to, setting up a regulated work area, decontamination of equipment and personnel, health and safety, etc., as well as construction costs such as excavation, loading and transportation. Materials determined to be RACS must be handled according to the RACS SOP and disposed of at the Denver-Arapahoe Disposal Site. Tipping fees associated with disposal at the Denver-Arapahoe Disposal Site will be paid for separately by the owner.

METHOD OF MEASUREMENT

All work including monitoring, material handling, sampling and testing, loading, containerization and disposal of soil will be paid according to the basis of payment.

BASIS OF PAYMENT

| Pay Item | Pay Unit |
|--|-----------------|
| Environmental Health and Safety Management | Lump Sum |
| Health Safety Officer | Hours |
| Materials Management Plan Supervisor | Hours |
| Certified Asbestos Building Inspector | Hours |
| Material Sampling and Delivery - Chemical | Each |
| Material Sampling and Delivery - Asbestos | Each |
| Solid Waste Excavation and Transporting | Cubic Yards |
| Asbestos Containing Material Abatement | Lump Sum |
| A/A - Air Monitoring Specialist | A/A |
| A/A - RACS Excavation, Loading, and Transportation | A/A |

END OF SECTION

Contract Control No. 2021-PROJMSTR-0000693

May 24, 2022

**REVISION OF SECTION 403
HOT MIX ASPHALT**

Section 403 of the Standard Specifications is hereby revised for this project as follows:

Section 403.01 shall include the following:

Areas to be paved with hot mix asphalt that are less than 8-feet in width shall be considered patching. Depth of HMA shall match the existing pavement sections.

Sawcutting of pavement to a neat line is required for pavement removal and placement of patching, and is incidental to the removal item.

Sections 403.02 through 403.06 are hereby deleted and replaced with the following:

Asphalt pavements shall be provided in accordance with MGPEC Volume 1 "Pavement Design Standards and Construction Specifications" included in this document.

END OF SECTION

**REVISION OF SECTION 503
DRILLED AND VACUUMED CAISSON**

Section 503 of the Standard Specifications is hereby revised for this project as follows:

Section 503.01 shall include the following:

This work consists of constructing the Traffic Signal Pole Foundations using a drill or vacuum method at the locations as shown on the plans and as directed by the Engineer. The placing of reinforcing steel and concrete in the excavated holes must in accordance with these specifications and in conformity with the lines and grades on the plans or established.

Traffic Signal Pole Foundations shall conform to the requirements of the City and County of Denver's Standard Details for Signal Pole Foundations (Detail 16.1.8).

Section 503.03, delete the first paragraph and replace with the following:

Caisson excavations performed with a vacuum pothole machine will be to prevent drilling through existing utilities. The locations where vacuum method is employed shall be at the discretion of the Engineer.

Section 503.08 is hereby revised to include the following:

Drilled or Vacuumed Caissons will be measured by the linear foot from the elevation shown on the plans to the bottom of the hole excavated.

Section 503.09 is hereby revised to include the following:

| Pay Item | Pay Unit |
|--------------------------|-----------------|
| Drilled Shaft (XX Inch) | Linear Foot |
| Vacuumed Shaft (XX Inch) | Linear Foot |

The unit price of drilled or vacuumed shaft (XX Inch) shall be full compensation for making all excavations; hauling and disposal of excavated material; performing all necessary pumping; furnishing and placing required concrete and anchor bolts and reinforcement steel, including the reinforcement projecting above the tops of the caissons necessary for splicing; all backfilling; removing casings; and for furnishing all tools, labor, equipment, and incidentals necessary to complete the work. No extra payment will be made for casing left in place.

END OF SECTION

Contract Control No. 2021-PROJMSTR-0000693

May 24, 2022

**REVISION OF SECTION 504
PLANTER WALLS**

Section 504 of the Standard Specifications is hereby revised for this project to include the following:

Subsection 504.01 shall include the following:

This work consists of furnishing and constructing a curb/retaining wall system for the various planters at the locations and to the lines and grades shown on the plans. This work includes the concrete, reinforcing, excavation, and backfill or disposal of all material required for the construction of the planters.

Subsection 504.02 shall include the following:

Unless otherwise specified on the plans, wall backfill material shall conform to the requirements for Structure Backfill (Class 1) of Section 206.

Concrete for the curb wall shall, forebays and weirs to be Concrete (Class D) conforming to the requirements of Section 601.

Reinforcing steel shall be epoxy coated.

Weirs, forebays and Type C prefabricated openings shall be designed in accordance with the details on the plans and as defined in the Denver Green Continuum Streets Guidelines.

Subsection 504.13 is deleted and replaced with the following:

Construction requirements for the planter wall shall conform to the applicable requirements of Section 206 and 601.

Subsection 504.43 shall include the following:

Planter walls will be measured by the linear foot in place.

Water Quality Planter Walls will be measured by the linear foot of wall and weir in place. Forebays and Type C prefabricated openings will not be measured separately for payment but shall be incidental to the Water Quality Planter Wall item.

Subsection 504.44 shall include the following:

The accepted quantities will be paid for at the contract unit price per unit of measurement for the pay items listed below:

Payment will be made under:

| Pay Item | Pay Unit |
|----------------------------|-----------------|
| Concrete Planter Wall | Linear Foot |
| Water Quality Planter Wall | Linear Foot |

Payment will be full compensation for all work and materials required to construct the curb wall. Structure excavation, structure backfill, concrete, reinforcing, forming and any miscellaneous items required to construct the planter walls will not be measured and paid for separately but shall be included in the work.

END OF SECTION

Contract Control No. 2021-PROJMSTR-0000693

May 24, 2022

**REVISION OF SECTION 514
FENCE (SPECIAL)**

Subsection 514 of the Standard Specifications is hereby revised as follows:

Subsection 514.01 shall include the following:

Fencing (Special) to prevent entry or occupation of the space below the bridge girders between the abutment and retaining wall. Fencing shall be provided where the space between bottom of girder and wall exceeds six inches (6"). Height of fence shall vary to match the opening height up to seventeen inches (17"). Fence shall be fastened to top of walls and face of abutment.

In spaces less than 6-inches in height Contractor shall install bird spikes to prevent birds from standing on the wall.

Subsection 514.03 is revised to include the following:

Fence (Special) shall match the existing fencing removed from the top of wall during demolition of the existing bridge and be constructed of Steel tubing.

Contractor to submit shop drawings of layout, materials and fastening method for approval, prior to fabrication.

Subsection 514.07 is revised to include the following:

Fence (Special) will be measured by the linear foot and include design, fabrication, welding, corner posts, fasteners, and painting as needed to complete the item in place.

Subsection 514.08 is revised to include the following:

| Pay Item | Pay Unit |
|--------------------------|-----------------|
| Fence (Special)(XX Inch) | Linear Foot |

END OF SECTION

SECTION 519
THIN BONDED OVERLAY (POLYESTER CONCRETE)

Section 519 is hereby added to the Standard Specifications for this project as follows:

DESCRIPTION

519.01 This work consists of furnishing and placing a Polyester Polymer Concrete (PPC) overlay system with a high molecular weight methacrylate (HMWM) resin primer on bridge concrete surfaces. The surface of the concrete shall be prepared and the PPC overlay system shall be applied in accordance with these specifications in conformity with the lines, grades, thickness, and typical cross-sections shown on the plans or as approved by the Project Manager.

MATERIALS

519.02 The Contractor shall submit a certified test report from independent accredited laboratories for each of the materials associated with the polyester concrete overlay in accordance with subsection 106.13.

The PPC shall consist of polyester resin binder and aggregate as specified herein. It shall also include a compatible primer which, when mixed with other specified ingredients and applied as specified herein, is capable of producing a polyester concrete meeting the requirements of this specification.

519.03 Polyester resin binder: Polyester resin binder shall have the following properties:

1. Be an unsaturated isophthalic polyester-styrene co-polymer. The resin content shall be 12 percent \pm 1 percent of the weight of the dry aggregate.
2. Contain at least 1 percent by weight gamma-methacryloxypropyltrimethoxysilane, an organosilane ester silane coupler.
3. Be used with a promoter that is compatible with suitable methyl ethyl ketone peroxide and cumene hydroperoxide initiators.
4. Have the values for the material properties in accordance with Table 519-1.

Accelerators or inhibitor may be required to achieve proper setting time of polyester concrete. They shall be used as recommended by the overlay System Provider.

-2-

SECTION 519
THIN BONDED OVERLAY (POLYESTER CONCRETE)

Table 519-1 Polyester Resin Binder Properties (Test each lot sent to the job)

| Property | Test Method | Requirement |
|---|-------------|---|
| Viscosity* | ASTM D2196 | 0.1x10 ⁻⁵ to 2.9x10 ⁻⁵ psi sec (0.075 to 0.20 Pa) RVT No.1 Spindle, 20 RPM at 77 °F |
| Specific Gravity* | ASTM D1475 | 1.05 to 1.10 at 77 °F |
| Elongation | ASTM D638 | 35% minimum Type I specimen, thickness 0.25 ± 0.03 inches at Rate = 0.45 inch/minute |
| | ASTM D618 | Sample Conditioning: 18/25/50+5/70 |
| Tensile Strength | ASTM D638 | 2,500 psi minimum Type I specimen, thickness 0.25 ± 0.03 inches at Rate = 0.45 inch/minute |
| | ASTM D618 | Sample Conditioning: 18/25/50+5/70 |
| * Test shall be performed before initiator is added | | |

519.04 High Molecular Weight Methacrylate (HMWM) Primer: Primer for the concrete surface shall be a wax-free, low odor, high-molecular-weight methacrylate primer, and consist of a resin, initiator, and promoter. The primer shall conform to Table 519-2 and the promoter shall be as recommended by the system provider.

Initiator for the methacrylate resin shall consist of a metal drier and peroxide. If supplied separately from the resin, the metal drier shall not be mixed with the peroxide directly. The containers shall not be stored in a manner that allows leakage or spilling to contact the containers or materials of the other.

Table 519-2 High Molecular Weight Methacrylate Resin (Tested yearly)

| Property | Test Method | Requirement |
|--|--------------------------------------|---|
| Viscosity* | ASTM D2196 | 4.0x10 ⁻⁵ psi (0.025 Pa) maximum (Brookfield RVT with UL adapter, 50 RPM at 77 °F) |
| Volatile Content* | ASTM D2369 | 30% maximum |
| Specific Gravity* | ASTM D1475 | 0.90 minimum at 77 °F |
| Flash Point | ASTM D3278 | 180 °F minimum |
| Vapor Pressure* | ASTM D323 | 0.04 inch Hg maximum at 77 °F |
| PCC Saturated Surface-Dry Bond Strength (Adhesive) | Colorado Procedure – Laboratory 4302 | 700 psi minimum at 24 hours and 70 ± 1 °F (with polyester concrete at 12% resin content by weight of the dry aggregate) |
| *Test shall be performed before initiator is added | | |

519.05 Aggregates: Polyester concrete aggregate shall have the following properties:

1. The aggregate shall not have more than 45 percent crushed particles retained on the No. 8 sieve when tested in accordance with AASHTO Test Method T335.
2. Fine aggregate shall consist of natural sand.
3. The aggregate shall have a weighted-average aggregate absorption of no more than 1 percent when tested under AASHTO Test Methods T84 and T85.
4. At the time of mixing with resin, the aggregate shall have a moisture content of not more than one half of the weighted-average aggregate absorption when tested under AASHTO Test Method T255.

-3-

SECTION 519
THIN BONDED OVERLAY (POLYESTER CONCRETE)

5. The aggregate shall meet the requirements for aggregate gradation in Table 519-3.

Table 519-3 Aggregate Gradation (Tested yearly)

| Sieve Size | Percent Passing |
|--------------------|-----------------|
| $\frac{3}{8}$ inch | 100 |
| No. 4 | 62-85 |
| No. 8 | 45-67 |
| No. 16 | 29-50 |
| No. 30 | 16-36 |
| No. 50 | 5-20 |
| No. 100 | 0-7 |
| No. 200 | 0-3 |

Sand for abrasive sand finish shall have the following properties:

- The sand shall be commercial-quality blast sand.
- At least 95 percent of the sand shall pass the No. 8 sieve and at least 95 percent shall be retained on the No. 20 sieve when tested under AASHTO Test Method T27.
- The sand shall have an average absorption of not more than 1 percent when tested under AASHTO Test Method T85.

519.06 Composite System: The composite material shall meet the requirements of Table 519-4.

Table 519-4 Composite Properties (Tested every two years)

| Property | Test Method | Requirement |
|-----------------------|--------------------------------------|--|
| PPC (Bond Strength) | Colorado Procedure – Laboratory 4302 | 500 psi minimum at 24 hours and 70 °F (without primer, at 12% resin content by weight of the dry aggregate, on Saturated Surface Dry Specimen) |
| Abrasion Resistance | Colorado Procedure – Laboratory 4301 | <2g weight loss (at 12% resin content by weight of the dry aggregate) |
| Modulus of Elasticity | ASTM C469 | 1,000,000 psi to 2,000,000 psi (at 12% resin content by weight of the dry aggregate) |

CONSTRUCTION REQUIREMENTS

519.07 Qualifications: The Contractor shall submit the overlay system, system provider qualifications, contractor qualifications, system provider technical representative qualifications, overlay placement plan, equipment, certificates of compliance with laboratory testing for each property, and any other relevant documents for the overlay system at least 15 working days prior to the polyester overlay pre-paving conference and delivery of any of the overlay materials. These submittals shall be approved by the Project Manager.

- Overlay System:* The Contractor shall submit two copies of the System Provider's material information, written installation instructions, material safety data sheets, and independent test results for approval.

-4-

SECTION 519**THIN BONDED OVERLAY (POLYESTER CONCRETE)**

2. *System Provider Qualifications:* The Contractor shall install an overlay system with all components provided through a single System Provider, with documented experience successfully supplying five projects of similar size and scope within the past five years. The Contractor shall submit documentation of the System Provider's project experience including the following:
 - a) Project construction date
 - b) Overlay quantities
 - c) Reference name and contact information of owner's representative
3. *Contractor Qualifications:* The Contractor shall submit documentation of completing five successful projects placing polyester polymer concrete systems on bridge decks or concrete pavement to established grade lines using similar equipment as specified herein within the past 5 years. The documentation of Contractor's qualifications shall include the following:
 - a) Project construction date
 - b) Overlay quantities
 - c) Reference name and contact information of owner's representative

The Contractor shall arrange for a qualified system provider technical representative with 5 years of documented experience with PPC to be on-site throughout the duration of the PPC operation to provide technical support for the materials. Once the Contractor has demonstrated an acceptable experience level with the PPC, the requirement to have the Technical Representative continuously on-site during the PPC operation may be reduced at the Project Manager's discretion.

4. *System Provider Technical Representative Qualifications:* The system provider technical representative shall have a minimum of 5 years of experience with PPC and be knowledgeable in all aspects of the work, including all materials to install the overlay system. The technical representative shall have experience on a minimum of five successful projects of similar size and scope within the past 5 years. The Contractor shall submit documentation of the system providers technical representative's experience including the following:
 - a) Years of experience working with polyester concrete
 - b) Project construction dates
 - c) Overlay quantities
 - d) Reference name and contact information for owner representatives

The Technical Representative shall be available on-site while the Contractor is placing the overlay system to facilitate the installation of polyester concrete to provide technical support for the materials. This includes, but is not limited to, trial slab preparation and PPC application, deck surface preparation and PPC application, and PPC cure. Once the Contractor has demonstrated an acceptable experience level with the PPC, the requirements for the on-site Technical Representative may be reduced at the Project Manager's discretion.

-5-

SECTION 519**THIN BONDED OVERLAY (POLYESTER CONCRETE)**

5. *Overlay Placement Plan:* The Contractor shall submit an Overlay Placement Plan that includes the following:
- a) Schedule of overlay work and testing for each bridge
 - b) Staging plan describing overlay placement sequence including:
 - i) Paving widths
 - ii) Anticipated paving lengths
 - iii) Paving directions:
 - (a) Contractor shall pave from high side of the bridge to the low side.
 - (b) No gaps between passes will be allowed.
 - iv) Joint locations: Cold joints between passes shall be within 1 foot of the lane lines.
 - v) Location of proposed trial overlay(s)
 - c) Description of equipment used for:
 - i) Surface preparation including grinding and shot blasting
 - ii) Applying HMWM resin
 - iii) Measuring, mixing, placing, and finishing the polyester concrete overlay
 - iv) Applying sand
 - v) Method of protecting and finishing inlets and bridge drain
 - d) Method for preventing leakage of primer onto areas of deck that have not received surface preparation
 - e) Method for isolating expansion joints including pourable joints at the abutment and over the piers
 - f) Method for measuring and maintaining overlay thickness and profile
 - g) Tining plan showing tining locations and describing methods that will be used for hand tining. Mainline tining shall be automated with the finisher.
 - h) Cure time for polyester concrete.
 - i) Storage and handling of HMWM resin and polyester concrete components.
 - j) Procedure for disposal of excess HMWM resin, polyester concrete, and containers.
 - k) Procedure for cleanup of mixing and placement equipment.

-6-

SECTION 519**THIN BONDED OVERLAY (POLYESTER CONCRETE)**

6. *Equipment:* The Contractor shall submit documentation of certification of scales that will be used to calibrate the mobile mixing truck. The certification shall be dated within one month of the start of the placing of the Overlay System. A new certification shall be done if any adjustments are made to the scales.

The Contractor shall submit a documented history of the use of the paving machine to successfully place Polyester Polymer Concrete overlays on major bridge projects for review and approval by the Project Manager.

7. *Materials Samples:* Samples of materials, from the same lots used for the project, for all components of the overlay system shall be submitted to the Engineer a minimum of seven working days prior to the overlay application. Samples shall be representative of the materials to be used in the overlay application and shall consist of one 4-liter sample for each liquid and a 5-pound sample for each dry component. The Contractor shall perform a minimum of one gradation analysis per project of combined sand and aggregate taken from the belt during production. Additional gradations may be required as directed by the Project Manager.

519.08 Polyester Overlay Pre-Paving Conference. A pre-paving conference shall be held before any overlay paving operations begin. Attendees shall include all parties involved in the work.

519.09 Trial Application: Prior to constructing the overlay, one or more trial applications shall be placed on a concrete base to determine the initial set time and to demonstrate the effectiveness of the mixing, placing, and finishing equipment proposed. The set time shall be determined when the in-place PPC cannot be deformed by pressing with a finger, indicating the resin binder is no longer in a liquid state. Each trial application shall be the planned paving width and a minimum of 20 feet long, with the same thickness as the specified overlay. The trial applications shall be tined as per the tining requirements in this specification for the final application. The trial applications shall replicate field conditions and be constructed using all the equipment that is used in the production work including the paving machine and volumetric mixer. The location of the trial applications shall not be on the bridge deck or approach slab and shall be approved by the Project Manager. Trial applications shall be properly disposed of off-site by the Contractor.

The number of trial applications required shall be as many as necessary for the Contractor to demonstrate the ability to construct an acceptable trial overlay section and competency in ability to perform the work.

Overlay pull bond testing shall be performed in accordance with the acceptance testing described herein. Acceptable test results shall be achieved on a trial application before the installation may proceed.

The methods, installer, or overlay system may be rejected after three trial applications if not shown to be adequate or in compliance with this specification as ordered by the Project Manager.

519.10 Equipment: All equipment for cleaning the existing concrete surface and mixing and applying the overlay system shall be in accordance with the System Provider's recommendations as approved by the Project Manager prior to commencement of work.

1. *Measuring Equipment:* The following equipment shall be used:
 - a) Certified Scales used to calibrate the mobile truck mixing equipment
 - b) Means to measure the resin levels in the tank of the mobile truck mixer during paving operations and access to the resin tank

-7-

SECTION 519**THIN BONDED OVERLAY (POLYESTER CONCRETE)**

2. *Mixing Equipment.* A continuous mixer shall be used for all polyester concrete overlay applications. The Contractor shall submit a written calibration plan that is specific to the Contractor's continuous mixing truck(s). The calibration plan shall be submitted a minimum of seven days prior to use of the mixer(s). The continuous mixer shall:
- a) Employ an auger screw/chute device.
 - b) Be equipped with an automatic metering device that measures and records aggregate and resin weights and/or volumes. Record weights or volumes at least every five minutes, including time and date. Submit recorded volumes at the end of the work shift.
 - c) Have a visible readout gage that displays weights or volumes of aggregate and resin being recorded.
 - d) Produce a satisfactory mix consistently during the entire placement.
 - e) Be calibrated by certified scales provided by the Contractor. Calibration shall be verified by demonstrating that the computer tickets from the metering device are within 2 percent of the certified scale weights. With the Project Manager witnessing, the Contractor shall produce three consecutive batches of aggregate that have batch tickets and actual material weights that are within 2 percent of each other, and three consecutive batches of resin that have scale weight tickets and actual material weights that are within two percent of each other. The calibration shall be verified at the beginning of the project, and the calibration shall be done every 60 days.

A portable mechanical mixer of appropriate size for proposed batches, as recommended by the System Provider and approved by the Project Manager, may be used for all PPC patching applications and for smaller area applications of less than 4,000 square feet per bridge or pavement section.

3. *Finishing Equipment:* A self-propelled slip-form paving machine, which is modified or specifically built to effectively place the PPC overlay in a manner that meets these specifications, shall be used for all polyester concrete overlay applications. The paving machine shall:
- a) Employ a vibrating pan to consolidate and finish the PPC.
 - b) Be fitted with hydraulically controlled grade automation to establish the finished profile. The automation shall be fitted with profile grade averaging devices on both sides of the new placement. The sensor shall be constructed to work with string-line control. A 30-foot ski grade control device may be used in locations where traffic restricts the use of string-line control. It is acceptable to match grade when placing lanes adjacent to previously placed PPC.
 - c) Be equipped with controls capable of maintaining the screed at the specified transverse slope.
 - d) Have sufficient engine power and weight to provide adequate vibration of the finishing pan while maintaining consistent forward placement speed.
 - e) Have mainline tining automated with the finisher.

-8-

**SECTION 519
THIN BONDED OVERLAY (POLYESTER CONCRETE)**

- f) Be capable of forward or reverse motion.

519.11 Surface Preparation: For newly constructed bridge decks and approach slabs, the deck shall cure a minimum of 28 days and attain the required Field Compressive Strength per Section 601 prior to overlay placement.

The surface of concrete substrate shall be prepared for application of the overlay by shot blasting in order to remove all existing grease, slurry, oils, paint, dirt, striping, cure compound, membrane, and all other contaminants that could interfere with the proper adhesion of the overlay system. Steel shot shall comply with SSPC-AB3 and recycled steel shot shall comply with SSPC-AB2.

The final prepared surface shall adhere to the following requirements:

1. The areas to be overlaid shall be cleaned by shot blasting. Areas not accessible by shot blast shall be abrasive blast. Cleaning shall not commence until all work involving the repair of the concrete deck surface has been completed and the deck is dry. All contaminants shall be picked up and stored in the vacuum unit and no dust shall be created during the blasting operation that will obstruct the view of motorists in adjacent roadways. The travel speed and/or number of passes of the shot blasting unit shall be adjusted so as to result in all weak or loose surface mortar being removed and the aggregates of the concrete being exposed, as well as a visible change in the concrete color. Cleaned surfaces shall not be exposed to vehicular traffic unless approved by the Project Manager. If the deck becomes contaminated before placing the overlay, the Contractor shall shot blast or abrasive sandblast the contaminated areas, per recommendation of the System Supplier's Technical Representative, and to the satisfaction of the Project Manager at no additional cost to the project.
2. All loose particles shall be removed prior to the overlay placement by magnets and compressed air and vacuuming such that no trapped particles remain. Power washing will not be allowed.
3. The areas to be overlaid shall be blown off with compressed air just prior to placement of the primer and shall be completely dry.

519.12 Application of Overlay: Methods shown in this specification are typical of general installations and may be modified per the System Provider's recommendations as approved by the Project Manager. The application of the overlay shall not begin until the deck patches have cured for five days, completely surface dry in accordance with ASTM D4263 or have a moisture content of five percent or less when measured by a moisture meter approved by the Project Manager. Actual surface conditions at the time of overlay placement shall be evaluated based on more than just time to dry. The surface shall be free of any standing water or darkening of the surface that would indicate locations of previously standing water. The entire surface to receive PPC overlay shall uniformly appear light in color and show no further lightening when drying methods such as compressed air or propane torch are applied. There shall be no evidence of moisture in substrate cracks. The concrete surface temperature shall be between 40 °F rising and 100 °F falling, or per System Provider's recommendation, whichever is higher or lower, respectively. Stockpiled materials shall not be stored on the bridge deck.

HMWM Primer Application: Immediately before placing primer, all exposed surfaces shall be completely dry and blown clean with oil-free compressed air. Exposed surfaces shall be protected from precipitation and heavy dew during and after the application of the primer.

-9-

**SECTION 519
THIN BONDED OVERLAY (POLYESTER CONCRETE)**

After the exposed surfaces have been prepared and allowed to dry, primer shall be applied in accordance with the System Provider's recommendations. Primer shall be placed within five minutes of mixing at approximately 90 square feet per gallon, or at the rate recommended by the system provider.

Primer shall be uniformly spread to completely cover surfaces to be overlaid. Primer shall be applied with push brooms or rollers. Care shall be taken to avoid excess application that results in puddling. Excess material shall be removed or distributed to meet the required application rate. Primer shall be reapplied to any areas that appear dry after 15 minutes of absorbing the material. Primer shall not be allowed to leak onto areas that have not received surface preparation.

Polyester Concrete Application: The polyester concrete shall be applied after 15 minutes and within two hours after the primer has been applied. The polyester concrete shall be placed prior to gelling or 15 minutes following addition of initiator, whichever occurs first, or within a more restrictive range if recommended by the system provider.

The polyester resin binder shall be initiated and blended completely. Aggregate shall be added and mixed for at least 2 minutes when a portable mechanical mixer is used.

Polyester concrete shall have an initial set time of at least 30 minutes and at most 120 minutes when tested using an initial-setting time. The set time shall be determined in the field when the in-place PPC cannot be deformed by pressing with a finger, indicating that the resin binder is no longer in a liquid state. If the initial set is not within 30 to 120 minutes, the material shall be removed and replaced. Shorter set times may be required if suggested by the System Provider and approved by the Project Manager.

The overlay shall be consolidated and finished to the required grade and cross-section using a PPC paver as defined herein.

Placement of the overlay to the profile and cross-section shall be controlled by taut reference line string-lines on both sides of the paver. Placement and finishing equipment shall use the string-lines as a reference for automatic hydraulic control of finished grade. The reference elevation and string-line shall be established by the Contractor and is subject to approval by the Project Manager.

Although the paver should yield a finished surface, additional finishing may be necessary. PPC shall be finished as necessary through traditional concrete finishing methods, producing a slight resin bleed indicating complete consolidation of aggregates.

A surface friction sand finish of at least 2.2 pounds per square yard shall be broadcast onto the glossy surface immediately after finishing and before resin gelling occurs. Surface friction sand shall be broadcast after finishing and prior to tining by hand; if the tining device is mounted directly to the paving machine the surface friction sand shall be broadcast after tining. To ensure adequate pavement friction, the completed PPC overlay surface shall be free of any smooth or "glassy" areas such as those resulting from insufficient quantities of surface aggregate. Any such surface defects shall be repaired by the Contractor in the manner recommended by the System Provider and approved by the Project Manager at no additional cost to the project.

The overlay shall be longitudinally tined unless Plans indicate that the overlay shall be textured per CDOT Standard Specification 601.15(e)2.

Tining shall produce grooves of 1/8 inch by 1/8 inch spaced at 3/4 to 1 inch apart. Tining grooves shall be neat in appearance and uniform in depth. Tining devices shall be maintained clean and free from encrusted mortar, polyester resin, sand, and polyester concrete to ensure uniform groove thickness.

-10-

SECTION 519**THIN BONDED OVERLAY (POLYESTER CONCRETE)**

Unless indicated on the plans, tining shall run parallel with the direction of traffic and shall extend across the entire applied deck surface except for 1 foot next to the curb. The tining shall not be performed too early whereby the grooves may close, or too late whereby the grooves are of inadequate depth.

Polyester concrete overlay edges shall be tapered if the overlay is not completed within the allowable lane closure time and is more than $\frac{3}{4}$ inch higher in elevation than the adjacent pavement.

If the overlay thickness is greater than $\frac{3}{4}$ inch in height, longitudinal polyester concrete tapered edges parallel to the direction of traffic shall be tapered to not less than a 4:1 (H:V) slope. Transverse temporary asphalt tapered edges perpendicular to the direction of traffic shall be tapered to not less than a 50:1 (H:V) slope. Longitudinal polyester tapers may remain and be overlaid with polyester concrete overlay. Transverse temporary asphalt tapers shall have a bond breaker and be completely removed prior to overlay placement.

Saw Cut Joints: Saw cutting and sealing of all joints shall be done according to the joint specifications and the details in the plans. The time of sawing shall be determined by the Contractor to prevent random cracking and raveling from the sawing. The time will be dependent upon weather conditions, temperature, and other factors affecting the setting of the polyester concrete. If uncontrolled cracking occurs, the Contractor shall repair the crack as recommended by the System Provider and as approved by the Project Manager.

Curing: The Contractor shall protect the overlay from moisture for a minimum of four hours. The Contractor shall allow the overlay to cure sufficiently before subjecting it to loads or traffic of any nature that may damage the overlay. Cure time depends upon the ambient and deck temperatures. The overlay shall be considered cured to a firm, hard state when 4 hours have passed or a minimum reading of 25 on a properly calibrated Schmidt hammer.

519.13 Acceptance Testing. Acceptance of the deck patch, surface preparation, and thin bonded overlay will be determined by the Project Manager based on materials sampling, moisture transmission tests, vertical axis pull bond tests, and smoothness quality testing performed by the Contractor.

Materials Sampling: Contractor shall provide access to equipment in order to acquire materials samples and measuring of resin binder levels in the resin tank of the mobile mixing truck.

Deck Patch Moisture Transmission Testing: Moisture transmission tests shall be performed by the Contractor using the Plastic Sheet Method in accordance with ASTM-D4263. This test consists of an 18 inch by 18-inch square of clear plastic sheeting that is sealed to the concrete surface with tape on all four sides. If after 16 hours any condensation is found on the underside of the plastic or if the concrete surface is darkened, the test will be considered failing. An alternative to the plastic sheet method is a moisture meter test, with a moisture meter approved by the Project Manager, with a passing moisture reading on the patch or patches, of 5 percent or below. The patches to be tested will be approved by the Project Manager.

Overlay Pull Bond Testing: Vertical axis pull bond tests shall be performed after 24 hours by the Contractor in accordance with ASTM C1583, Standard Test Method for Tensile Strength of Concrete Surfaces and the Bond Strength or Tensile Strength of Concrete Repair and Overlay Materials by Direct Tension (Pull-Off Method). A minimum of two pull bond tests shall be performed on each bridge. For bridges with deck areas greater than 15,000 square feet, additional tests shall be performed at a frequency of one test per 15,000 square feet of additional deck area, rounded up. Additional testing may be required as directed by the Project Manager.

The test result shall be the average of the number of tests for each structure, drilled a minimum of 0.25 inches but no greater than 0.50 inches below the bond line.

-11-

SECTION 519**THIN BONDED OVERLAY (POLYESTER CONCRETE)**

The bond strength of the PPC overlay system on normal weight concrete shall be 250 pounds per square inch. An acceptable test will demonstrate that the overlay bond strength is sufficient by producing a concrete subsurface failure area greater than 50 percent of the test surface area. The Contractor shall repair all bond test locations with polymer overlay in accordance with this specification.

Smoothness Quality Testing: The finished transverse and longitudinal surface elevation of the pavement shall be measured using a 10-foot straightedge. Areas to be measured will be as directed by the Project Manager. The Contractor shall furnish an approved 10-foot straightedge, depth gauge, and operator to aid the Project Manager in testing the pavement surface.

519.14 Corrective Work.

Repair of Surface Defects: The repair materials and finishing methods for surface defects in the overlay shall be in accordance with those used for the application of the overlay. All surface defects shall be repaired to the satisfaction of the Project Manager before acceptance of the work.

Correction for Smoothness: Areas showing high spots of more than 3/16 inch in ten feet shall be marked and diamond ground until the high spot does not exceed 3/16 inch in 10 feet. Longitudinal tining shall be grooved to restore the longitudinal texture (tining). Areas showing low spots of more than 3/16 inch in ten feet shall be marked, saw cut, removed with diamond grinding, and replaced at the Contractor's expense.

Replacement of Defective Overlay: A defective overlay, identified by sounding for delamination or a failing pull bond test result, shall be removed, and replaced at the Contractor's expense. The Contractor shall submit a written corrective work proposal to the Project Manager, which shall include the methods and procedures that will be used. The Contractor shall not commence corrective work until the methods and procedures have been approved in writing by the Project Manager. The Project Manager's approval will not relieve the Contractor of the responsibility of producing work in conformity with the Contract.

Defective Tining: If the Project Manager determines tining to be unacceptable on any deck surfaces measuring 30 square feet or more, based on criteria in CDOT Standard Specifications subsection 519.12(b), the tined surface shall be repaired with resin and the repaired surface shall be textured per requirements in subsection 601.15(e)2.

519.15 Furnish Thin Bonded Overlay (Polyester Concrete) will be measured by the actual quantity of polyester concrete material complete-in-place and accepted. The volume shall include material used for patching Class 1 removal areas as shown on the plans. Any additional quantities in excess of the plan thickness as required for profile adjustments shall be included in the Contractor's submittal and approved by the Project Manager prior to placement.

-12-

SECTION 519
THIN BONDED OVERLAY (POLYESTER CONCRETE)
METHOD OF MEASUREMENT AND PAYMENT

The Contractor shall collect a weight ticket for all material placed and ensure that the following information is shown on each ticket:

1. Project Number
2. Bridge Number
3. Date and Time
4. Ticket Number
5. Material Type
6. Location of Placement (Lane and Station Limits)
7. Aggregate Weight
8. Polyester Resin Binder Weight

Tickets shall be available on-site for project personnel to inspect.

Each day, the Contractor shall provide to the Project Manager separate envelopes for each bridge which contains the previous day's weight tickets and the following:

1. On each envelope: Project number, bridge number, date of paving, type of material, daily total, cumulative total, and suppliers name.
2. One of the following:
 - a) Two adding machine tape tabulations of the weight tickets with corresponding totals run and signed by different persons.
 - b) One signed adding machine tape tabulation of the weight tickets that has been checked and signed by a second person.
 - c) Signed check tape of computer scale tickets that have a cumulative total. These scale tickets must be consecutive.
3. A comparison of the actual yield for each day's placement to the theoretical yield. Theoretical yield shall be based on the actual area paved and the planned thickness of the mixture being placed. Any variance greater than 5 percent shall be indicated on the envelope with a written explanation included.

Place Thin Bonded Overlay (Polyester Concrete) will not be measured, but will be the quantities, in square yards, specified on the plans for the final surface.

-13-

SECTION 519
THIN BONDED OVERLAY (POLYESTER CONCRETE)

519.16 The accepted quantities will be paid at the contract unit price for each of the pay items listed below that appear in the bid schedule.

-13-

SECTION 519**THIN BONDED OVERLAY (POLYESTER CONCRETE)**

Payment will be made under:

| Pay Item | Pay Unit |
|--|-----------------|
| Furnish Thin Bonded Overlay (Polyester Concrete) | Cubic Foot |
| Place Thin Bonded Overlay (Polyester Concrete) | Square Yard |

Construction and removal of trial applications including concrete base surfaces will not be measured and paid for separately but shall be included in the work.

Payment for Furnish Thin Bonded Overlay (Polyester Concrete) will be full compensation for all costs required to furnish the polyester concrete material, including freight, to the project site and disposal of any unused overlay material. All costs for time, labor, materials, and equipment for all necessary trial slabs shall be included in the Furnish Thin Bonded Overlay (Polyester Concrete). Payment by cubic foot will be based on an average of three-unit weight tests on three separate samples. A unit weight of 135 pounds per cubic foot may be used as the basis of payment if the unit weight tests become impractical at the Project Manager's discretion.

Payment for Place Thin Bonded Overlay (Polyester Concrete) will be full compensation for all labor, materials, tools, equipment, and incidentals required to prepare the concrete surface and complete the overlay placement. Quantities for placement of patching areas will not be measured and paid for separately but shall be included in the work.

Costs for placement of polyester concrete material in class 1 removal areas will not be measured and paid for separately but shall be included in the work.

END OF SECTION REVISION

**REVISION OF SECTION 522
DUPLEX COATING SYSTEM**

Section 522 of the standard specifications is hereby added to the Standard Specifications for this project as follows:

DESCRIPTION

522.01 This work consists of hot dip galvanizing and duplex coating steel structures as shown in the Contract.

MATERIALS AND CONSTRUCTION REQUIREMENTS

522.02

- (a) *General.* The Contractor shall provide, install, and repair if necessary, all steel items that are prepared and coated in conformance with this Section. All repair and replacement of the finished coating necessary for final acceptance shall be at the Contractor's expense.

Steel products to be galvanized and coated shall be cleaned of weld spatter and bevel finished at exposed corners, edges and points. Areas having welds, cuts, bores, notches, or grooves shall also be beveled unless otherwise noted in the Contract or directed by the Engineer. Bevel work shall produce a uniform, smooth finish for galvanizing. Bevel size to be used is based on steel thickness and other criteria as follows:

| Steel Thickness/Type | Bevel Size (inches) |
|--------------------------|-----------------------------|
| Less than ½" thick | 1/32" to 1/16" |
| Over ½" thick | 1/16" to 1/8" |
| Bores, notches & grooves | root face of 1/32" to 1/16" |

Welds shall be cleaned and finished according to AWS standards.

All coating measurements shall be taken with a Type 2 fixed probe Dry Film Thickness (DFT) gauge. The gauge shall be calibrated, and measurements shall be taken, according to the Society for Protective Coatings (SSPC) Standard PA-2.

- (b) *Galvanizing.* Galvanizing shall be done in accordance with the Contract requirements and AASHTO M 111 (ASTM A123) for the type of material being galvanized, except that items shall only be quenched with ambient air. The poles and arms for traffic signals and signs shall be hot dipped galvanized inside and outside. Chromate treatment of any type will not be permitted. Zinc-phosphate pretreatment or acrylic passivation pretreatments shall be as described in (d) below.

The Contractor shall submit a certificate of compliance (COC), conforming to subsection 106.12, confirming that all materials meet or exceed the galvanizing requirements described herein.

All galvanized surfaces shall be free from drips, slag or surface irregularities.

Spot areas not requiring galvanizing shall be marked and cleanly patched with material that prevents galvanization but does not weaken the adjacent spelter coating. Repair of patched areas shall be achieved by metallizing as described in (c) below.

-2-

**REVISION OF SECTION 522
DUPLEX COATING SYSTEM**

Prior to galvanizing, the Contractor's galvanizer shall notify the Engineer in writing that the galvanized order is chromate free and air quenched. Products not certified chromate free by the Contractor's galvanizer shall be tested prior to galvanizing. The Contractor shall provide the Engineer with certification from an independent ASTM accredited laboratory listing all individual items that test chromate free. Testing shall comply with ASTM D-2092 Appendix X2. Test results shall be provided to the Engineer prior to galvanizing.

- (c) *Repair of Galvanized Products.* Uncoated areas or damaged coating exceeding applicable specification limits shall be re-galvanized to meet the original specification requirements. Cuts made after galvanizing shall be ground, beveled, and smoothed before repair. Damaged galvanized areas shall be re-galvanized or metallized.

Re-galvanizing shall conform to ASTM A-780, Annex A1. Metalizing shall conform to ASTM A-780, Annex A3, except that minor repair areas shall be cleaned according to SSPC method SP-3. SSPC Method SP-2 may be used to clean difficult access areas. Thickness of the repair coat shall match adjacent galvanizing, as measured by a calibrated DFT gauge.

Coating imperfections such as burring, runs or drips, high spots, heavy dross, or ash inclusion shall be removed and cleaned at the Contractor's expense. Areas of re-work falling below zinc thickness limits shall be repaired at the Contractor's expense.

Printed Technical Data Sheets (PTDS) shall be provided to the Engineer for repair materials used.

- (d) *Preparing Galvanized Surfaces for Coating.* Products shall be inspected for shipping and handling damage before surface preparation begins. Damage shall be reported to the Contractor's galvanizer and to the Engineer prior to repair. The Engineer will determine whether damaged items are to be repaired or replaced. Minor repair of galvanizing shall conform to (c) above, and shall be at the Contractor's expense.

The Contractor shall prepare each surface to be coated so that it has a slightly roughened profile without removing over 1.0 mil of the galvanized coating. Minimum ASTM zinc thickness specifications shall still apply after preparation.

Surfaces of fasteners to be coated shall be lightly brushed or sanded in a manner that will remove the least amount of zinc.

Surfaces that become soiled after pretreatment shall be cleaned prior to coating by low pressure, mild detergent wash and rinse. Stained or oiled surfaces may also be mildly scrubbed with a soft bristle nylon brush. Stubborn stains may be mildly scrubbed with a mix of 1 - 2 percent ammonia solution and thoroughly rinsed. Wash and rinse pressure shall not exceed 100 psi at 185° F temperature.

Surface preparation work shall be done according to one of the following methods:

1. *Zinc-Phosphate Pretreatment.* This treatment may be used only on new galvanizing less than 48 hours of age.

Items shall be immersed in a bath of acidic zinc-phosphate solution for 3 - 6 minutes, rinsed with clean water, and dried. The first epoxy coat shall be applied within 48 hours after immersion treatment.

-3-

**REVISION OF SECTION 522
DUPLEX COATING SYSTEM**

If treated items are shipped to a different coating facility they shall be rewashed, rinsed and dried to remove surface soiling. The first epoxy coat must still be applied within 48 hours after immersion treatment.

2. *Acrylic Passivation Pretreatment.* This treatment may be used only on fresh hot galvanizing or new galvanizing less than 48 hours of age. Only chrome-free solutions shall be used, applied by a method that ensures complete coverage of all surfaces to be coated. The Contractor shall provide the Engineer with treatment dates for each item and the PTDS for the solutions used. The Contractor's galvanizer may apply solution to fresh hot galvanizing that is less than 6 hours of age, still clean, and dry and that has cooled to treatment application temperature guidelines.

If newly galvanized items are shipped to another treatment facility they shall be washed, rinsed and dried to remove surface soiling. The solution shall then be applied and cured according to the supplier's instructions.

Fully cured and treated items shall be rewashed, rinsed, and dried again just before coating. Items not coated within 100 days of treatment shall be abrasive blasted in conformance with subsection (d) 3.

3. *Abrasive Blasting.* This treatment may be used on galvanized items of any age if beveling requirements as listed in the third and fourth paragraphs of subsection (a) have been met. The Contractor shall notify the Engineer in writing at least five working days before blasting begins. Zinc thickness shall be measured and recorded immediately after blasting and provided to the Engineer within 48 hours of blasting. Thickness limits and measurement frequency shall comply with the original applicable ASTM specification. Blast operations shall reasonably conform to ASTM Standard Practice D-6386, Subsection 5.4.1 except for small areas falling below required zinc thickness. These areas shall be repaired in accordance with subsection (c). No single area shall exceed 2 inches at its largest width or 12 inches at its longest dimension. The total repair area shall not exceed 1 percent of the coatable surface of the item; if limits are exceeded or zinc thickness is below the specification requirement, the item shall be re-galvanized in conformance with the original specification.

The Contractor shall measure and record the size, location and repair method used for all repairs. This information shall be included on the report of thickness measurements.

The first epoxy coat shall be applied within 24 hours of abrasive blasting. Items shall be cleaned free of blast debris before coating. Compressed air used to clean items shall be free of oil, residue, oil and other harmful contaminants.

Thickness measurement is not required after surface preparation work has been completed.

- (e) *Coating and Paint Systems.* Prepared items shall be coated with a two or three coat system described in this subsection. Alternative coating systems shall be pre-approved in writing by the Engineer. Manufacturer's PTDS for each coating type shall state test values for ASTM requirements of this subsection. Prior to product use the coating supplier shall provide the PTDS and certify to the Engineer in writing that all furnished coating materials meet applicable requirements of this subsection.

-4-

**REVISION OF SECTION 522
DUPLEX COATING SYSTEM**

Faying surfaces shall not be painted unless written approval is given by the Engineer. All shop fabrication, including welds and attachments, shall be completed prior to coating unless otherwise specified in the Contract or directed in writing by the Engineer.

Inorganic zinc coatings shall not be used. Combined DFT of all coats applied over the galvanizing shall range from 6.5 to 10 mils with a topcoat DFT of 3 mils minimum. Dried color of the base coat and topcoat shall be visually contrasting. Finished color shall not vary more than 4 ΔE^*_{ab} units from the specified color determined in accordance with ASTM D 2244.

Volatile Organic Compound (VOC) levels shall not exceed 3.5 pounds per gallon for each applied coat. Dry films shall contain less than 1 percent lead and other toxic heavy metals. The zinc concentration of each epoxy coat shall not exceed 40 percent. Top coats shall have a semi-gloss value of 50-75.

All coatings shall be able to withstand temperatures up to 180° F without sag, blister, or peel damage. Topcoat formulation shall provide weathering, chemical, and ultraviolet (UV) resistance. All coatings shall meet the following ASTM requirements as amended:

- (1) Corrosion Weathering. ASTM D-5894, minimum 6-cycles of exposure:
Corrosion rating of 8 or higher according to ASTM D-1654.
Blistering rating of 8 or higher according to ASTM D-714.
- (2) Impact Resistance. ASTM D-2794, 30 day test:
Epoxies – Minimum 40 inch-pounds
All Topcoats – Minimum 90 inch-pounds
- (3) Adhesion Testing. ASTM D-4541, 30 day test, Minimum 500 psi for either: Method B - flat surface or Method E - curved surface.
- (4) Abrasion Resistance. ASTM D-4060, 30 day test: Maximum 90 mg loss after 1000 cycles with a CS10 or CS17 wheel.
- (5) Flexibility. ASTM D-522, 30 day test - Method B: Epoxies shall pass a 180 degree bend over a ¾ inch mandrel. All Topcoats shall pass a 180 degree bend over a 3/8 inch mandrel.

Each coat shall be applied uniformly to provide an appearance free of laps, streaks, sags, drips, pinholes, and other discontinuities; all such defects shall be repaired prior to product shipment.

The Contractor's coater shall measure the DFT of each applied coat according to SSPC, Guide PA-2, except that measurements shall be taken with a calibrated Type 2 fixed probe gauge. Thickness records shall be provided to the Engineer prior to project shipment. The following two coating systems do not require pre-approval:

1. Powder Coating. The Contractor's coater shall oven preheat the articles to abate out-gassing potential. The Contractor's coater shall use compatible materials and coating processes to obtain proper coat to coat adhesion.

The epoxy powder base coat shall measure 2 to 6 mils DFT and be applied by electrostatic or airstatic spray. The powder formulation shall be a non-hybrid epoxy of anti-gassing grade.

-5-
REVISION OF SECTION 522
DUPLEX COATING SYSTEM

The powder topcoat shall be electrostatic or airstatic spray applied and measure 3 to 6 mils DFT. The powder formulation shall be a non-acrylic, high-build, aliphatic-based, enhanced polyester or urethane polyester of anti-gassing grade.

2. Liquid Coating. The Contractor's coater shall apply coats by conventional or airless spray according to the supplier's guidelines. Minimal striping at difficult work areas is permissible. The Contractor's Coater shall use proper work methods and compatible materials to obtain proper coat adhesion. Thinning of paints shall be done according to the manufacturer's instructions so that thinned products conform to the solids content and VOC limits of this subsection.

The epoxy base coat shall measure 2 to 6 mils DFT. Paint shall be a low-blush epoxy polyamide, or a low-blush cycloaliphatic bisphenol-A polyamine. Minimum solids by weight of all epoxies used shall be 68 percent.

The topcoat shall measure 3 to 6 mils DFT. Paint shall be an aliphatic-based urethane polyester or aliphatic-based polyurea urethane. Specially formulated aliphatic-based polyaspartic polyureas may also be used over compatible epoxy bases.

- (f) *Repair of Coated Products.* The Contractor shall repair damage from shipment, installation, field welding, or other activity during the construction. Damage shall be reported to the Engineer prior to repair. Repairs shall be as directed by the Engineer.

Significant repair procedures require written submittal of a proposed repair process from the Contractor. The Engineer shall approve the proposal in writing before repairs begin. Significant repairs are classified as:

- (1) Any damaged area to the base coat material over 1 square inch
- (2) Total repair areas exceeding 5 percent of the coating per item
- (3) Any single topcoat repair area over 64 square inches

Minor and touchup repair of topcoats shall be done as follows:

A UV rated, aliphatic-based liquid topcoat paint shall be used. The paint shall be compatible with the existing topcoat material and closely match existing color. The paint shall meet the requirements of subsection (e). The paint supplier shall provide the Engineer with PTDS for the products used.

Single areas smaller than 8 square inches requiring repair shall be scuffed with 220 grit sandpaper or equivalent scuff material. Larger areas up to 64 square inches may be cleaned according to SSPC, Method SP-2. All border areas at the undamaged topcoat shall be scuffed with 220 grit material.

Cleaned, scuffed areas shall be bordered and coated by airless or conventional spray. Work areas shall be adequately shielded to contain errant spray. Fresh repair areas shall be protected as necessary during the initial cure. Repair thickness shall reasonably match the adjacent coating.

The repair coat shall provide an appearance free of sags, runs, streaks, drips, pinholes, or other discontinuities. Spray can paint repair shall not be used.

-6-

**REVISION OF SECTION 522
DUPLEX COATING SYSTEM**

(g) *Conditions for Final Acceptance of Coating.* Within six weeks immediately prior to final project acceptance, the Engineer and a representative of CDOT's Staff Bridge Branch will conduct a final inspection of the coating. The Contractor's Superintendent shall also attend the inspection. Before final project acceptance, the Contractor shall repair the following defects found during the inspection:

- (1) Peeling on any portion of the coatings.
- (2) Blistering on any portion of the coatings.
- (3) Color fading below a 35 gloss rating, in accordance with ASTM D523.
- (4) Mottling defects that exceed 3 percent of the topcoat surface.
- (5) Visible cracking of the topcoat material.
- (6) Visible rusting discoloration on the coating.
- (7) Sag or other evidence of coating adhesion loss.

METHOD OF MEASUREMENT AND BASIS OF PAYMENT

Duplex Coating System will not be measured and paid for separately, but shall be included in the work.

END OF SECTION

**REVISION OF SECTION 601
STRUCTURAL CONCRETE COATING (ANTI-GRAFFITI)**

Section 601 of the Standard Specifications is hereby revised for this project as follows:

Subsection 601.01 shall include the following:

This work consists of: (1) Application of Structural Concrete Coating (Anti-Graffiti) on all exposed concrete surfaces, except where noted otherwise; (2) surface preparation, providing and applying a one-component, non-sacrificial coating to all concrete surfaces, new and existing, as designated in the Plans.

The color(s) of the Structural Concrete Coating (Anti-Graffiti) shall be clear, and shall be approved by the Engineer from test panels provided by the CONTRACTOR. The anti-graffiti coating shall be applied to the test panels as specified in the Standard Specifications for Structural Concrete Coating.

The Anti-Graffiti Coating shall be the following product:
Sherwin-Williams
Protective & Marine Coatings
Anti-Graffiti Coating
1K Siloxane
Product Number: B97C00150

Another product will not be accepted.

Subsection 601.14 shall include the following:

Following the application of the Structural Concrete Coating, the concrete surface shall be prepared, and Structural Concrete Coating (Anti-Graffiti) applied, and in accordance with the coating Manufacturer's recommendations. At a minimum, the stained concrete surface shall be free of all dust, dirt, grease or other foreign matter detrimental to the bond of the coating to the surface.

Subsection 601.19 shall include the following:

Structural Concrete Coating (Anti-Graffiti) will not be re-measured but shall be the quantity shown on the plans; except that measurements will be made when field changes are ordered, or for an error of plus or minus five percent of the plan quantity.

Subsection 601.20 shall include the following:

The accepted quantities of Structural Concrete Coating (Anti-Graffiti) will be paid for at the contract unit price per unit of measurement for the Pay Items listed below.

Payment will be made under:

| Pay Item | Pay Unit |
|---|-----------------|
| Structural Concrete Coating (Anti-Graffiti) | Square Feet |

Payment shall be full compensation for all work necessary to complete the item and shall include, but not be limited to, sample preparation and test panels, surface preparation, and supply and application of anti-graffiti coating.

END SECTION

Contract Control No. 2021-PROJMSTR-0000693

May 24, 2022

**REVISION OF SECTION 603
CULVERTS AND SEWERS**

Subsection 603 of the Standard Specifications is hereby revised as follows:

Subsection 603.02 shall include the following:

Reinforced concrete pipe shall be manufactured from concrete that meets the requirements for severity of sulfate exposure Class 2 specified in subsection 601.04.

Pipe to pipe connections where the lateral is steeper than 45 degrees shall be reinforced at the connection point to prevent the lateral pipe from sliding into the main pipe, similar to Denver Wastewater Management Division Standard Detail Sheet S-450 "Inlet Connection into Storm Sewer". Contractor shall submit a detail for approval.

Subsections 603.03 through 603.11 shall be replaced with the City and County of Denver, Department of Public Works, Wastewater Management Division "Storm Drainage and Sanitary Sewer Construction Detail and Technical Specifications", hereby incorporated into this Section by reference for any and all work on City facilities.

The referenced documents can be found at the following website:

<http://www.denvergov.org/>

Compaction Method B as defined in the above replacement specifications shall be used.

Subsection 603.12 is revised to include the following:

Complete in Place (CIP) items shall include the following: structural excavation, shoring, dewatering, bedding, pipe joint, trench bulkheads, structural backfill, reinforced pipe connections, and any other miscellaneous items, materials, and labor needed to complete the installation of the pipe. These elements will not be measured and paid for separately but shall be included in the price of the pipe item.

Payment will be in accordance with the Measurement & Payment section of the above-referenced specifications.

END OF SECTION

Contract Control No. 2021-PROJMSTR-0000693

May 24, 2022

**REVISION OF SECTION 604
MANHOLES AND INLETS**

Subsection 604 of the Standard Specifications is hereby revised as follows:

Subsection 604.01 shall include the following:

This work shall include the construction of inlets, manholes and outlet structures needed to complete the drainage installation.

Subsection 604.02 shall include the following:

Concrete for these structures shall use concrete that meets the requirements for severity of sulfate exposure Class 2 specified in subsection 601.04.

Subsections 604.04 through 604.06 shall be replaced with the City and County of Denver, Department of Public Works, Wastewater Management Division “Storm Drainage and Sanitary Sewer Construction Detail and Technical Specifications”, hereby incorporated into this Section by reference for any and all work on City facilities.

The referenced documents can be found at the following website:

<http://www.denvergov.org/>

Compaction Method B as defined in the above replacement specifications shall be used.

Subsection 603.12 is revised to include the following:

Manholes, inlets and other special drainage structures, shall include the following: structural excavation, shoring, bedding, trench bulkheads, structural backfill, reinforced pipe connections, grating, filters, and any other miscellaneous items, materials, and labor needed to complete the installation of the pipe. These elements will not be measured and paid for separately but shall be included in the price of the pipe item.

END OF SECTION

**REVISION OF SECTION 412 AND 608
PAVEMENT, SIDEWALKS , CURB RAMPS, AND BIKEWAYS**

Section 608 of the Standard Specifications is hereby revised for this project as follows:

608.1 This work consists of the construction of concrete sidewalks and bikeways, and detectable warning indicators in accordance with these specifications and in conformity with the lines and grades shown on the plans or established.

MATERIALS

608.2 Materials shall meet the requirements specified in the following subsections:

| | |
|---------------------|--------|
| Joint Fillers | 705.01 |
| Bed Course Material | 703.07 |

Concrete shall be Class P and meet the requirements of Section 601.

Seal all concrete and pavers with clear, sealer meeting ASTM C-1315 that will not stain nor change color of concrete and pavers. Apply to test area and call Landscape Architect for approval prior to applying on entire project.

Concrete mixes will be subject to inspection and tests as required to assure compliance with quality requirements.

New Curb Ramps shall be standard gray and constructed with integral Truncated Domes per “City and County of Denver Department of Public Works Standards and Details for Engineering Division.” Truncated Domes within Parks maintained areas shall be unpainted grey cast iron plates conforming ASTM A-48 class 30.

1. 14th Street Intersection per Public Works Standards
2. Speer Boulevard Intersections shall be per Parks standards

All concrete used for sidewalks, and curb ramps shall be reinforced with polypropylene fibers. Polypropylene fibers shall be FIBERMESH or FORTA FIBRE. Length of fibers shall be as recommended by the manufacturer. Add 1.5 pounds FIBERMESH or FORTA FIBRE per cubic yard of concrete.

Colored concrete shall be integrally colored at the rate of 4 pounds per sack of cement, or of an equal color and intensity approved by the Project Manager and cured with a non-pigmented "clear" curing compound. The Project Manager may adjust the color additive \pm one pound, if desired.

Concrete Finishes: The following concrete finishes are for the sidewalk, roadway, and bikeway areas indicated on the plans:

1. Cast in place Concrete Paving – Gray
 - a. Color: Uncolored
 - b. Finish: As noted on drawings
2. Cast in place Concrete Paving – Red
 - a. Color: Davis Integral Color Tile Red (#1117) or equal
 - b. Finish: Match Existing

-2-

**REVISION OF SECTION 412 AND 608
PAVEMENT, SIDEWALKS , CURB RAMPS, AND BIKEWAYS**

3. Cast in place Concrete Paving – Integral Color Type A
 - a. Color: Davis Integral Color – Light Grey – Iron Oxide (#860) or equal
 - b. Finish: Light Broom
4. Cast in place Concrete Paving – Integral Color Type B
 - a. Color: Davis Integral Color - Mesquite (#677) or equal
 - b. Finish: Medium Broom

Colored and uncolored concrete for sidewalks, bikeways, and curb ramps shall be Class P, and meet the requirements of Section 601.

Detectable Directional Warning Tiles

Manufacturer: Armor-Tile or an approved equal <https://armor-tile.com/detectable-directional/>

Product: Detectable Directional Tile

Size: 12” in width

Color: Brick Red

Attachment method: per manufacturers recommendations

608.3 Submittals

Submit samples of all materials to Landscape Architect for approval prior to starting mock-up. Submittals shall include a 4’ X 4’ mockup of each type of concrete specified indicating color, finish and all jointing. Test panel shall include one transverse control joint and one expansion joint and finished with a light to medium broom finish. The samples shall be placed on site and be representative of requirements stated herein. All samples approved by the Project Landscape Architect, shall be retained on site until project completion and act as the project standard. If for any reason the Project Landscape Architect or Project Manager does not find the sample acceptable it shall be removed and replaced up to five (5) times at the contractor’s expense.

CONSTRUCTION REQUIREMENTS

608.4 Sidewalks, Curb Ramps and Bikeways.

- (a) *Excavation.* Excavation shall be made to the required depth and to a width that will permit the installation and bracing of the forms. The foundation shall be shaped and compacted to a firm even vertical and horizontal surface conforming to the section shown on the plans or as staked. When the Engineer determines that material is uncompactable, the material shall be overexcavated and removed and replaced in accordance with subsection 206.03.
- (b) *Forms.* Forms shall be of wood, metal, or other suitable material, and shall extend for the full depth of the concrete. All forms shall be straight, free from warp and of sufficient strength to resist the pressure of the concrete without springing. Bracing and staking of forms shall be such that the forms remain in both horizontal and vertical alignment until their removal. All forms shall be surveyed to comply with all horizontal and vertical requirements shown in the plans, and to meet existing and or proposed adjacent improvements.

-3-

**REVISION OF SECTION 412 AND 608
PAVEMENT, SIDEWALKS , CURB RAMPS, AND BIKEWAYS**

- (c) *Placing Concrete.* Upon confirmation of subgrade and accuracy of horizontal and vertical grades and geometry per the plans, the foundation shall be thoroughly moistened, without ponding or standing water, immediately prior to the placing of the concrete. The proportioning, mixing and placing of the concrete shall be in accordance with the requirements for the class of concrete specified. If the contractor selects and gains approval by the Engineer to utilize concrete pumping apparatus, the terminal trunk end shall not exceed 10 vertical feet drop from the chute.

The Contractor shall insure that new concrete items built under this contract drain properly and, as such, there are no areas of standing water on new concrete items.

- (d) *Finishing.* The horizontal surface shall be floated with a wooden or magnesium float and given a finish as shown in the drawings. Plastering of the surface will not be permitted. Tooled joints shall penetrate 1/3 the depth of the concrete pour. Tooled joints shall not leave a penetration or shine upon completion. All required hand finishing shall be performed in conformance with subsection 601.12(a).
- (e) *Joints.* Expansion joints, at intervals shown in the drawings, shall be filled with ½ inch thick full depth, preformed expansion joint filler. The sidewalk or bikeway shall be divided into sections by dummy joints formed by a jointing tool or other acceptable means as directed. These dummy joints shall extend into the concrete for at least 1/3 of the depth and shall be approximately 1/8 inch wide. Dummy joints shall be spaced at intervals shown in the drawings.

Construction joints shall be formed around all appurtenances such as manholes, utility poles, etc., extending into and through the sidewalk. Preformed expansion joint filler ½ inch thick shall be installed in these joints. Expansion joint filler ½ inch thick or the thickness indicated shall be installed between new concrete and any fixed structure such as a building or bridge. This expansion joint material shall extend for the full depth of the contact surface. Provide and apply approved joint sealant. Expansion joint material must be left below adjacent finished surfaces allowing installation of sealant to be flush or just below adjacent finished surfaces.

Contraction (Control) Joints in Walks and Roadway: Sawcut joints are acceptable and shall meet requirements of Section 601. Contraction joints shall be formed with power saws equipped with shatterproof abrasive or diamond-rimmed blades. Cut one-eighth inch (1/8") wide joints into concrete that has hardened sufficiently that cutting action will not tear, abrade, or otherwise damage surface, but before development of random contraction cracks. Saw cut joints shall be spaced at a distance equal to the width of the walk, but not over ten feet (10') unless approved by the Project Manager. Depth of joints shall be one-fourth (1/4) the slab thickness. Any joints that will be sawcut must be preapproved prior to execution of the sawing activity and discussed in a preconstruction meeting gaining approval prior to pouring of concrete.

Tooled joints will not be allowed on concrete sidewalks, unless directed by the Project Manager.

Steel reinforcing bars shall comply with Section 601 and be installed and secured to maintain locations as shown in the drawings. Expansion joints in vertical walls shall include rebar as shown with papered ends.

- (f) *Curing.* Immediately upon completion of the finishing, sidewalks and bikeways shall be moistened and kept moist for three days, or they shall be cured by the use of membrane forming curing compound. The method and details of curing shall be subject to the approval of the Engineer.

During the curing period all traffic, both pedestrian and vehicular, shall be excluded. Vehicular traffic shall be excluded for such additional time as the Engineer may direct.

-4-

**REVISION OF SECTION 412 AND 608
PAVEMENT, SIDEWALKS , CURB RAMPS, AND BIKEWAYS**

Vertical concrete forms shall be maintained until concrete has cured prior to form removal at the discretion of the Engineer.

- (g) *Finishing.* Review drawings to gain full understanding of the different finishing techniques prescribed.

Broom Finish for bikeway shall be medium broom finish applied in perpendicular to flow of traffic or 90 degrees to back of curb. Broom finish for sidewalk shall be medium broom finish perpendicular or 90 degrees to direction of traffic.

- (h) *Steel Reinforcing.* Refer to Section 601 for all reinforcing steel requirements.

- (i) *Directional Warning Tiles.* Tiles shall be installed between intersections to direct sight impaired persons to stay in the designated walk areas. Tiles shall be installed continuously as shown on the plans.

Subsection 608.06 shall include the following:

| Pay Item | Pay Unit |
|--|-----------------|
| Concrete Pavement (6") (Colored) | Square Yard |
| Detectable Directional Warning Tiles | Linear Foot |
| Detectable Warning Surface (Cast Iron) | Square Foot |
| Detectable Warning Surface | Square Foot |

All work necessary and incidental to the construction of sidewalks and bikeways, will not be measured and paid for separately but shall be included in the work.

REVISION OF SECTION 412

Section 412 of the Standard Specifications is hereby revised for this project as follows:

Subsection 412.02 shall include the following:

Colors for concrete pavement shall be as noted above in revision to subsection 608.02

Subsection 412.13 shall include the following:

Dowel bars required for concrete pavement, including curbs or tying into existing pavement, shall be as defined in the City of Denver Transportation Standards and Details for the Engineering Division Dwg 11.0-11.9.

Contractor shall submit jointing plans for approval 10 days prior to commencing paving.

END OF SECTION

**REVISION OF SECTION 613
ELECTRICAL CONDUCTOR IDENTIFICATION**

Section 613 of the Standard Specifications is hereby revised for this project as follows:

Subsection 613.08 shall include the following:

All electrical conductors shall be tagged as follows:

Electrical conductor cable tags shall be located below the termination in the base of the streetlight, in the pull box, in the pedestal, and at the point of termination to existing facilities of the Local Utility

Company supplying electrical service. The tags shall be attached with a cable tie. The information written on the tag shall include the direction and approximate length of cable, feeds running from where and to, etc.

Each incoming conductor shall be individually color coded with one (1) tape mark, while outgoing conductors shall have two (2) tape marks.

Example:

| | |
|----------------------|-------------------|
| ----- | |
| FEEDS TO PULL BOX | FEEDS FROM XFMR |
| 50' NORTH & 75' WEST | 250' SOUTH & EAST |
| THEN TO HIGHWAY SIGN | 200' WEST |
| ----- | |

Uniform tags are available in a Tag Kit. *The Tag Kit consists of: 100 tags, 3-part yellow with 1 hole, 100 black nylon ties and 1 black Sharpie pen.

| | |
|----------------------|------------------------|
| <u>Manufacturers</u> | <u>Catalog Numbers</u> |
| Uticom Systems Inc. | U5025Y1 |
| Or approved equal | |

Subsection 613.14 shall include the following:

Electrical conductor tagging will not be paid for separately, but shall be included in the cost of wiring.

END OF SECTION

**REVISION OF SECTION 613
ELECTRICAL CONDUIT – GENERAL**

Section 613 of the Standard Specifications is hereby revised for this project as follows:

Add the following to subsection 613.07:

This work is for the installation electrical conduits. These conduits (laterals) shall be to connect the already installed traffic signal conduits to the traffic signal controller cabinets, electric meters, pedestrian lights, street lights, bridge underdeck lighting, and traffic signal poles. The conduit installation shall be in accordance with this specification:

All conduit bends, including factory-installed bends, shall not have a bend radius less than six times the inside diameter of the conduit.

The excavations required for the installation of conduit or cable shall be performed in such a manner as to avoid unnecessary damage to streets, sidewalks, landscaping, sprinkler systems and other improvements. Trenches shall not be excavated wider than necessary for the installation of the electrical appurtenances. Excavation shall not be performed until immediately before installation of conduits. The material from the excavation shall be placed in a position not to cause damage or obstruction to vehicular or pedestrian traffic or interfere with surface drainage.

Trenches shall be made with a rock-wheel or other machine capable of cutting a narrow trench (4") so as to allow traffic to pass over prior to back filling. The machine shall be equipped with shields to direct the spoil downward and away from passing vehicles, workmen and pedestrians.

Off-street trenches shall be back-filled with the same material that was removed and shall be compacted and shaped to match the surrounding surface. On-street trenches within ALL roadway areas shall be back-filled with CDOT approved Structure Backfill (Flow-Fill) and capped with 9" minimum of Hot Mix Asphalt Pavement (Patching) in accordance with Section 403 and City and County of Denver Street Cut Regulations if applicable. If surrounding pavement depth is greater than 9 inches, the HMA (Patching) depth shall match the existing pavement.

All surface materials including sprinkler systems, landscaping, shrubs, sod grass, and native growth vegetation which is disturbed by trenching and back-filling operation shall be restored in kind equal to or exceeding the original conditions.

All conduit runs that will not have a copper conductor installed shall have a #12 AWG stranded copper conductor placed inside for locating purposes. Locating conductor and tape will not be measured and paid separately, but shall be included in the unit price for conduit.

Conduit shall always enter a pull box, hand-hole, or any other type structure from the direction of the run only.

All conduits shall be fully compatible with fiber optic cable. Plastic conduit shall be Schedule 80 in the diameters shown on the plans and shall be compliant with Bellcore TW-NWT-000356 requirements. Each conduit shall be equipped with a pull tape and each bore shall have a copper tracer wire of at least 12 gauge.

Plastic PVC conduit shall be certified by the manufacturer as meeting ANSI/UL 6 and 651. The manufacturer shall be ISO 9000 compliant.

-2-

**REVISION OF SECTION 613
ELECTRICAL CONDUIT – GENERAL**

All conduit bends, including factory-installed bends, shall not have a bend radius less than six times the inside diameter of the conduit.

Conduit plugs for sealing conduit shall also be supplied and installed in all open conduit ends as soon as the conduit is installed. Plugs shall be durable, fabricated from no metallic parts, be of the split design to allow removal and reinstallation around in-place cables and be easily removable and reusable. Plugs shall be capable of being installed by hand without any tools and shall provide a water and air tight seal of at least 100 psi and shall cause no damage to the cable when installed.

At some locations (as illustrated on the Plans or in these specifications, or as directed by the Engineer), new conduits shall be installed in an existing pull box. At these locations, the Contractor shall carefully excavate around the pull box and install the new conduit in the pull box in a manner that meets the requirements of this Special Provision. The Contractor shall not damage the existing pull box. If the existing pull boxes or concrete collars are cracked or damaged during conduit installation, the Contractor shall be required to replace either or both conforming to the requirements of the contract at no additional cost.

Subsection 613.10 shall include the following:

Electrical Conduit will be measured by the linear feet of conduit and installed in accordance with these Special Provisions, the Project Standards or as directed by the Engineer. Electrical Conduit will include groundwork, sweeps, pull cord, copper tracer wire, adapters, fittings, splice couplings, conduit plugs (for conduits both with and without fiber optic cable), equipment, labor, and all other items necessary to complete the work.

Subsection 613.11 shall include the following:

| Pay Item | Pay Unit |
|-----------------------------|-----------------|
| 1" Electrical Conduit | Linear Foot |
| 1" Electrical Conduit (GRC) | Linear Foot |
| 2" Electrical Conduit | Linear Foot |
| 3" Electrical Conduit | Linear Foot |

Conduit shall be plastic (PVC) unless otherwise noted on the plans.

END OF SECTION

Contract Control No. 2021-PROJMSTR-0000693

May 24, 2022

**REVISION OF SECTION 613
ELECTRIC METER PEDESTAL CABINET AND BASE**

Section 613 of the Standard Specifications is hereby revised for this project as follows:

Subsection 613.07 shall include the following:

New lighting and traffic signal installations require an Electric Meter Pedestal Cabinet and Base. Xcel Energy will furnish only the electric meter. The Contractor shall furnish the electric meter pedestal cabinet, and shall install the pedestal cabinet and base, by a licensed electrician (journeyman), at the locations as show on the plan and in accordance with the City and County of Denver’s standard – sheets 16.1.19 and 16.1.20.

Subsection 613.10 shall include the following:

Electric Meter Pedestal Cabinet and Base will be measured and installed in accordance with these Special Provisions, the Project Standards or as directed by the City. The Electric Meter Pedestal Cabinet and Base installation will include groundwork, sweeps, pull cord, copper tracer wire, adapters, fittings, splice couplings, conduit plugs, equipment, labor, and all other items necessary to complete the work.

Contractor shall submit material specifications to the Engineer for prior approval.

Subsection 613.11 shall include the following:

Contractor shall submit material specifications to the Engineer for prior approval.

| Pay Item | Pay Unit |
|--|-----------------|
| Electric Meter Pedestal Cabinet and Base | Each |

END OF SECTION

Contract Control No. 2021-PROJMSTR-0000693

May 24, 2022

**REVISION OF SECTION 613
LIGHTING**

Section 613 of the Standard Specifications is hereby revised for this project as follows:

Subsection 613.02 shall include the following:

Installation shall conform to the City of Denver Street Lighting Design and Xcel Energy Guidelines.

The Contractor shall furnish and install LED luminaires on traffic signal poles in accordance with City of Denver standards at the locations shown on the plans.

The Contractor shall coordinate install of Xcel designed and installed LED Street Lights, Bridge underdeck lights, and Pedestrian Lights at locations as shown on the plans with Xcel Energy.

Luminaires shall be of the following types as noted on the Fixture Schedule in the plans:

| <u>Manufacturer</u> | <u>Catalog Series</u> | <u>Description</u> |
|-------------------------------------|--|---------------------------|
| GE Evolve | ERLH-016-B3-30-A-6012-035 (LED, 3000k) | Traffic Signals |
| For Information Only by Xcel | | |
| Kim Lighting | Ouro (LED 3000k 3000 Lumens) | P1 or P2 Pedestrian Light |
| GE Evolve | ERL1 Cobrahead (LED, 3000k, 4900 Lumens) | P3 Street Light |
| Cooper Lighting | UFLD-S (LED, 3000k, 3000 lumens) | U1 Underdeck Light |

The luminaire shall also include a 7-pin photo cell (S-T P124-1.5-PTW or equal). Luminaire finish:

Traffic Signal:

Color: Federal Green or approved by CCD.

For Information Only by Xcel

Street Light:

Color: Black or approved by CCD and Xcel

Pedestrian Light:

Color: Black or approved by CCD and Xcel

Underdeck Light:

Color: Black or approved by CCD and Xcel

For traffic signals, the Contractor shall submit a lighting materials list to the City and Denver for approval prior to ordering. Contact Matt Blessinger at 720-865-4066.

Subsection 613.04 shall include the following:

Pedestrian lights installed on the bridge approach slab shall have the anchor bolts and conduit installed during the approach slab and sidewalk construction in accordance with the plans.

Subsection 613.08 shall include the following:

For traffic signal light poles at least one grounding electrode shall be installed adjacent to each. Wiring shall be a 120/240 volt or 120/208 volt, 3-wire system with individual luminaire wired for 120 volts.

Wiring for street lights, pedestrian lights and underdeck lights shall be coordinated with Xcel.

-2-

**REVISION OF SECTION 613
LIGHTING**

Subsection 613.14 shall include the following luminaire, pole and foundation:

| Pay Item | Pay Unit |
|---------------------------------------|-----------------|
| Luminaire (LED)(5300 Lumens)(55 Watt) | Each |

Pedestrian light foundation on the approach slab will be paid for per the applicable type listed above.

Traffic Signal Luminaire shall be measured and paid by the number of luminaires installed. The item shall include all labor, materials, and ancillary hardware required to provide a fully-functional system to the satisfaction of the Engineer.

END OF SECTION

**REVISION OF SECTION 613
PULL BOXES – GENERAL**

Section 613 of the Standard Specifications is hereby revised for this project as follows:

DESCRIPTION

Subsection 613.01 shall include the following:

At locations shown in the plans, the Contractor shall install one or more pull boxes of the size and type indicated in the following section. This work shall also include the removal and replacement of existing pull boxes at locations specified in the plans and as directed by the Project Engineer.

MATERIALS

Subsection 613.02 shall include the following:

All traffic signal pull boxes, except surface mounted ones, shall be made of fiberglass reinforced polymer concrete and shall be designed to support a minimum service load of 15,000 pounds over a 10" x 10" square. Pull boxes shall be of the type specified in the plans. The pull box shall have a detachable cover that has a skid-resistant surface. Pull box size and general use are as follows:

Pull boxes that are installed to house traffic signal cables, specified as Pull Box (Type B) (Traffic), shall have the words "TRAFFIC SIGNAL" physically impressed (not painted) on its top. The traffic pull boxes shall have minimum inside dimensions of 30.5" long by 17.5" wide by 24" deep.

Electric pull boxes, specified as Pull Box (Type 1 or 2) (City Electric), shall have the words "CITY ELECTRIC" physically impressed on their top. The pull box shall have minimum inside dimensions of 20" long by 13" wide by 12" deep or as is consistent with CCD standard drawing DS-02 for type identified on plans.

Pull boxes that are installed for XCEL utility use shall be consistent with the size requirements listed in CCD standard drawing DS-02 and installed per current XCEL design and installation guidelines.

Pull boxes that are installed to house communication cables, specified as either Pull Box (Special) or Pull Box (Type C) (Comm), shall have the words "TRAFFIC COMM" physically impressed (not painted) on its top. The communication pull boxes shall have minimum inside dimensions of 30.5" long by 17.5" wide by 24" deep. The covers shall be attached to the pull box body by screw-in bolts and shall have two lift slots to aid in the removal of the lid.

Pull boxes that are to be in traveled ways shall be outfitted with traffic bearing lids rated for HS 20-44 loads. The pull boxes shall have a special concrete footing extending 8 inches around the outside and 6 inches around the inside of the pull box bottom, as shown in the plans. Pull boxes installed in dirt or landscape areas shall have a 12 inch wide by 6 inch thick concrete collar placed around the top in lieu of the concrete footing, as shown in the plans.

-2-

**REVISION OF SECTION 613
PULL BOX – GENERAL**

CONSTRUCTION REQUIREMENTS

At some intersections, existing pull boxes and conduits may need to be modified to accommodate minimum bend requirements of interconnect cable and/or splice closures. At the direction of the Engineer or Engineer's designee, the Contractor shall remove existing pull boxes and replace with a pull box large enough to meet the interconnect manufacturer's recommended minimum bend radius or the splice closure requirements. Replacement of pull boxes to accommodate these requirements will be paid for as Pull Box (Type C) (Comm), Pull Box (Type 2) (City Electric) or Pull Box (Type B) (Traffic) as specified in the plans.

The covers shall be attached to the pull box body by screw-in bolts and shall have two lift slots to aid in the removal of the lid.

Any surface mounted communication pull boxes shall be aluminum NEMA type enclosures, and are intended for above ground applications only. Enclosures shall be watertight with a lockable door (Type 4 or better rating) with minimum dimensions of 20" long by 16" high by 8 inches deep. Connection between surface mounted pull boxes and nearest communication pull boxes shall be by means of Liquid-tight Flexible Metal Conduit (LFMC).

METHOD OF MEASUREMENT

Subsection 613.11 shall include the following:

Pull Box (Type C) (Comm), Pull Box (Type 2) (City Electric), or Pull Box (Type B) (Traffic) shall include the removal of any existing pull box, installation of the new pull box, modification of conduit ends, restoration of disturbed surface materials, and all other work necessary to complete the installation. Pull boxes shall be measured and paid on the basis of the number of boxes installed as specified in the plans. The contract unit price for each pull box shall be full compensation for all work described above, specified in the plans and complete and in place.

Removal and Disposal of any existing pull boxes and associated material will not be measured and paid for separately, but shall be included in the work.

BASIS OF PAYMENT

Subsection 613.12 shall include the following:

Payment will be made under:

| Pay Item | Pay Unit |
|-----------------------------------|-----------------|
| Pull Box (Type A) (Electric) | Each |
| Pull Box (Type B) (Traffic) | Each |
| Pull Box (Type C) (Traffic Comm) | Each |
| Pull Box (Type 1) (City Electric) | Each |
| Pull Box (Type 2) (City Electric) | Each |

END OF SECTION

**REVISION OF SECTION 614
CONCRETE FOOTING (TRAFFIC SIGNAL POLE)**

Section 614 of the Standard Specifications is hereby revised to include the following:

Subsection 614.01 shall include the following:

This work consists of installing concrete footing (foundations) for traffic signal pedestal pole; traffic signal imbedded steel poles (span wire poles); and traffic signal street light poles (no mast arms). Locations of the concrete footing (foundations) are shown on the plans or as directed by the Engineer.

Subsection 614.08 (g) shall include the following:

Concrete Footing (Pedestal Pole) shall conform to the requirements of the City and County of Denver's Traffic Signal Standard Detail sheet no. 16.1.13 and detail nos. 4 and 5.

Concrete Footing (Imbedded Steel Pole) for span wire traffic signal poles shall conform to the requirements of the City and County of Denver's Traffic Signal Standard Detail sheet no. 16.1.14 and detail no. 6.

Concrete Footing (Traffic Street Light Pole – no mast arm) shall conform to the requirements of the City and County of Denver's Traffic Signal Standard Detail sheet no. 16.1.15, Foundations for XCEL Facilities, and detail no. 9.

Subsection 614.13 shall include the following:

Concrete Footings for Pedestal Poles, Imbedded Steel Poles, and Traffic Street Light Poles will not be measured and paid for separately but shall be included in the cost of Pedestal Poles, Imbedded Steel Poles, and Traffic Signal Light Poles installation.

END OF SECTION

**REVISION OF SECTION 614
LED PEDESTRIAN SIGNAL HEADS (COUNT DOWN)**

Section 614 of the Standard Specifications is hereby revised for this project as follows:

Subsection 614.01 shall include the following:

This work includes the installation of LED Pedestrian Signal Faces with countdown timers as shown in the Contract.

Subsection 614.08 (h) shall include the following:

Pedestrian signal faces with count down timers shall meet the following requirements:

- i. The dimensions of the signal housing and the LED symbols, as well as moisture and dust resistance requirements shall be in accordance with the current ITE PTCSI Standards.
- ii. Signal housing shall be aluminum, painted in Federal Green and “clam-shell” mounted.
- iii. The signal shall have user-selectable modes for countdown for walk cycle only, pedestrian cycle only, or both walk and pedestrian clearance.
- iv. The countdown module shall have an internal conflict monitor to prevent any possible conflicts between the Hand/Person signal indications and the time display. The display shall not countdown during a Solid Hand indication.
- v. LED symbols shall be solid icons and shall provide uniform light dispersion such that the “pixel” effect is minimized. Lettered or outline symbol styles will not be permitted.
- vi. The Man/Hand configuration shall provide clear and distinct lamination where either symbol is in use.
- vii. The LED module shall be rated for use in an ambient operating temperature range of 40° F to 165° F.
- viii. The signal shall meet NEMA Standard TS2 for voltage surge protection, and shall have an automatic reset in case of a power outage.

Subsection 614.13 shall include the following:

LED Pedestrian Signal Heads will be measured by the actual number of units that are installed and accepted.

Subsection 614.14 shall include the following:

Payment will be made under:

| Pay Item | Pay Unit |
|-----------------------------|-----------------|
| Pedestrian Signal Face (16) | Each |

END OF SECTION

**REVISION OF SECTION OF 614
TRAFFIC CONTROL DEVICES**

Section 614 of the Standard Specification is hereby revised as follows:

Subsection 614.08 (h) shall include the following:

“Light Emitting Diode” (LED) signal lenses shall be installed in all Red, Yellow, Green, signal displays. The LED signal lenses for the 12” and 8” circular balls and 12” circular arrows are hereby added to the Standard Specifications and shall comply with the following specifications:

Manufacturer Requirements and Approvals:

- The manufacturer supplying product to this specification shall have a minimum of 13 years of experience in the manufacture of LED Traffic Signals with High Flux LEDs used in the North American market.
- Manufacturers supplying products to this specification must be a registered participant and have the unique long life module part numbers being provided certified and listed on the Intertek-ETL LED Traffic Signal Modules Certification Program approved products website prior to bid opening.
- Manufacturers supplying products to this specification shall manufacture and assemble product on an Intertek ETL audited line located in the USA.
- Unique part number shall be listed on manufacturers label proving difference between standard modules and long life modules.
- If requested, documentation shall be provided by manufacturer demonstrating the changes made to their standard product that allows for ITE specification compliance over 15 year warranty period.

Physical & Mechanical Requirements:

General

- Tinted or Non-Tinted Lens. Unless designated otherwise in the below table the standard lens color shall be tinted with a color meeting the colors required in paragraph 4.2 of the ITE specification. The products shall be available with non-tinted lenses as an option.
- The LED module shall utilize high flux LEDs rated at 1 watt or higher and have an incandescent, non-pixelated appearance when illuminated. The use of low power LEDs, for example 5 mm LEDs, is not permissible in the design and production of long life arrow products.
- The external lens shall have a smooth outer surface to prevent the buildup of dirt/dust and shall be designed to minimize the potential for sun phantom signals.
- All LEDs utilized to illuminate circular signal modules, shall be LEDs that have been manufactured utilizing materials that have industry acceptance as being suitable for uses in outdoor applications. At no time is the use of LEDs that utilize AlGaAs technology acceptable.
- The thermal management system used in the traffic ball must be self-contained and internal to the traffic module. At no time shall the thermal management system used for the power supply or LEDs form any part of the external surface of the LED module.
- All plastic components shall be molded and assembled in the USA. This includes: back housing, spreading lens and front lens. Certificate of manufacturing location must be available and supplied at time of bid requested.
- All lenses shall be hard coated in the USA. Certificate of manufacturing location must be available and supplied at time of bid requested. All reflectors shall be metalized in the USA.
- Certificate of manufacturing location must be available and supplied at time of bid requested.

-2-

REVISION OF SECTION 614 TRAFFIC CONTROL DEVICES

Module Identification

- In addition to the required ITE labeling all modules must be labeled with the ETL Verified label shown in Figure 1. This label designates the compliance and listing with the Intertek- ETL Traffic Signal Certification Program.

Electrical:

General

- The following color scheme shall be used for all modules AC power leads: White for Common, Red for the Red ball signal, Yellow for the Yellow ball signal, and Brown for the Green ball signal.
- The AC power leads shall exit the module via a rubber grommetted strain relief, and shall be terminated with insulated female quick connect terminals with spade/tab adapters. The leads shall be separate at the point at which they leave the module.
- All external wiring utilized in the LED traffic signal module shall be anti-capillary type wire to prevent the wicking of moisture to the interior of the module.
- LED Module and power supply shall be design to remain ITE compliant over a 15 year life.
- To minimize the temperature exposure of the power supply all power supplies should be located at the bottom of the module when the arrow is facing left.
- For additional protection from moisture, all power supplies shall be conformal coated for additional protection.

Transient Voltage Protection

- In addition to the transient test requirements defined in the Design Qualification Testing section of ITE Vehicle Traffic Control Signal Heads (VTCSH) specification all power supplies used in the circular signals supplied to this specification shall be capable of passing an additional ring-wave surge testing in accordance with the IEEE Recommended Practice on Characterization of Surges in Low-Voltage (1000V and less) AC Power Circuits, ANSI/IEEE C62.41.2-2002, 6KV, 100 kHz ring-wave with an output impedance of 30 ohms. The short circuit current shall be 200 Amps.

Power

- Typical wattages at 25 °C for the 12" circular arrow LED traffic Signal Modules shall be: Red - 8 watts, Yellow - 13 watts, and Green - 8 watts.
- Typical wattages at 25°C for the 12" circular ball LED traffic Signal Modules shall be: Red – 7 watts, Yellow - 11 watts, and Green - 7 watts. Typical wattages at 25°C for the 8" circular ball LED traffic Signal Modules shall not exceed: Red - 8 watts, Yellow - 10 watts, and Green- 8 watts.

Quality Assurance

General

- Upon Request, the supplier must provide an Intertek-ETL test report for the base model being supplied to this specification.
- The base products must be listed in the Intertek Directory of LED Traffic Signal Modules Certified Products listing at the time of bid. Upon request the supplier must provide a copy of the listing in the bid package.

-3-

**REVISION OF SECTION 614
TRAFFIC CONTROL DEVICES****Warranty Requirements:****Warranty**

- Manufacturers shall provide a detailed written warranty issued by the factory of module origin with the following minimum provisions:
- Modules shall, at the manufacturer's option, be repaired or replaced if the module fails to function as intended due to workmanship or material defects within the first 15 years from the date of delivery.
- Modules shall, at the manufacturer's option, be repaired or replaced if the module exhibit luminous intensities less than the minimum specified values within the first 15 years of the date of delivery.
- Upon request, the LED lamp module manufacturer shall provide written documentation of its ability to satisfy a worst-case, catastrophic warranty claim.
- A current corporate annual report duly-certified by an independent auditing firm, containing financial statements illustrating sufficient cash-on-hand and net worth to satisfy a worst-case, catastrophic warranty claim is an example of suitable documentation.
- The documentation shall clearly disclose:
 - The country in which the factory of module origin is located
 - The name of the company or organization that owns the factory of module origin including any and all of its parent companies and/or organizations, and their respective country of corporate citizenship
- For firms with business and/or corporate citizenship in the United States of less than fifteen years, the process by which the end-users/owners of the modules will be able to obtain worst-case, catastrophic warranty service in the event of bankruptcy or cessation-of operations by the firm supplying the modules within North America, or in the event of bankruptcy or cessation-of-operations by the owner of the factory of origin, shall be clearly disclosed.

Subsection 614.14 shall include the following:

LED signal lenses shall be included in the cost of the item for Traffic Signal Face and will not be paid for separately.

END OF SECTION

REVISION OF SECTION 614 TRAFFIC SIGNAL CABINET BASE

Section 614 of the Standard Specifications is hereby revised for this project as follows.

Subsection 614.01 shall include the following:

This work is for the furnishing and installation of a composite Traffic Signal Controller Cabinet Base in accordance with City & County of Denver standards.

Dimensions of the cabinet base are as shown in the following drawing:

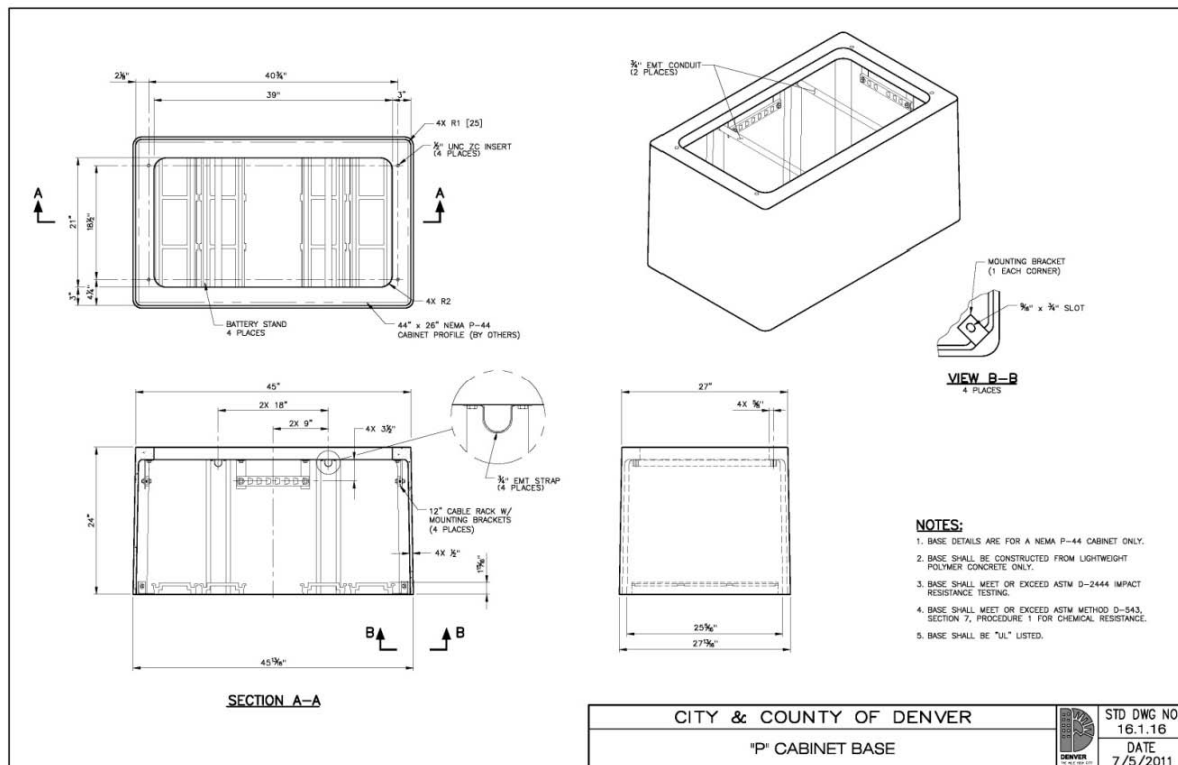

Subsection 614.10 shall include the following:

Prior to starting cabinet base installation, Contractor shall obtain field verification of the location of the cabinet from the Engineer.

Cabinet base installation shall include all labor and materials to completely install a new P-size cabinet base as directed in the plans. The item shall include all excavation, conduit installation and modification work, backfill and restoration of adjacent surface area.

Subsection 614.13 shall include the following:

Installation of the traffic signal cabinet base shall not be measured and paid for separately, but shall be included in the cost of the Traffic Signal Controller and Cabinet.

END OF SECTION

**REVISION OF SECTION 614
TRAFFIC SIGNAL CONTROLLER AND CABINET**

Section 614 of the Standard Specifications is hereby revised for this project as follows:

Subsection 614.01 shall include the following:

This work shall consist of the furnishing and installation of a completed Traffic Signal Controller and Cabinet assembly, malfunction management units (MMU), vehicle detector amplifiers, uninterrupted power supply (UPS), other ancillary hardware, and traffic signal cabinet base as per City and County of Denver standards. Delete Subsection 614.08 (b), and replace with the following:

Traffic Signal Controllers – General

This specification sets forth the minimum requirements for a shelf-mountable, two through twelve phases, fully-actuated, digital, solid-state traffic controller. The controller shall meet, as a minimum, all applicable sections of the NEMA Standards Publication No. TS2-1998. Where differences occur, this specification shall govern. Controller versions shall be available to comply with NEMA

TS2 Types 1 and 2. Type 2 versions of the controller shall be capable of operating as a Type 1. The controller shall meet or exceed the specifications of the Econolite model COBALT ATE Fully Actuated controller (http://www.econolite.com/docs/cobalt_atc_tough_hardware_specification.pdf), or an equivalent approved by the City and County of Denver Traffic Engineering Services.

Delete Subsection 614.08 (c) and replace with the following:

All new cabinets are the P-type cabinets as per the City & County of Denver Traffic Standards. Each cabinet shall be installed on a newly installed traffic signal controller cabinet base unless otherwise specified on the plan. Contact Chris Lillie at 720-865-0466 for cabinet assembly requirements and all other necessary auxiliary hardware.

Controller cabinet assemblies shall include an integrated uninterrupted power supply (UPS) units that comply with the City and County of Denver standards (see UPS specification).

Subsection 614.09 shall include the following:

The Contractor shall deliver the traffic signal controller, and cabinet assemblies and other auxiliary hardware, to the City and County of Denver Traffic Operations Center at 5440 Roslyn Street, Building E, Denver, Colorado 80216 six (6) weeks before installation for controller programming.

The Contractor shall coordinate the pick-up of the controller and cabinet assembly from the City and County of Denver's Traffic Engineering Services and shall install it at the proper location. The Contractor shall coordinate pick-up times with Chris Lillie at (720) 865-4066.

The controller shall be installed in accordance with the details shown in the plans and in accordance with manufacturer's recommendations.

-2-

**REVISION OF SECTION 614
TRAFFIC SIGNAL CONTROLLER AND CABINET**

Subsection 614.10 shall include the following:

The Contractor shall demonstrate successful traffic signal operations at all new controller and cabinet locations to the satisfaction of the Engineer or Engineer’s designee prior to acceptance of this item.

The Contractor shall contact the Engineer or Engineer’s designee 3 days before turning on signal. Work shall include all required programming of controllers and establishing or re-establishing all required wiring connections. Phasing and timing information at each location shall be furnished to the Contractor by the City & County of Denver.

All new wiring shall conform to City & County of Denver and International Municipal Signal Association (IMSA) specifications.

Subsection 614.13 shall include the following:

The unit price for the furnishing and installation of traffic signal controllers cabinets shall include all labor, materials, ancillary hardware, traffic signal cabinet base, wiring and wiring re-connection (including Xcel Energy power feed) required to provide and install a complete system and successful operation of the item. Connection of the controller to the fiber optic interconnect system shall be paid for separately under item 614 "Telemetry (Field)".

Removal and disposal of existing cabinets shall be in accordance with the Project Special Provision for the referenced item.

Subsection 614.14 shall include the following:

| Pay Item Pay | Unit |
|---------------------------------------|-------------|
| Traffic Signal Controller and Cabinet | Each |

END OF SECTION

**REVISION OF SECTION 614
ETHERNET MANAGED SWITCH**

Section 614 of the Standard Specifications is hereby revised for this project as follows:

Subsection 614.01 shall include the following:

This work consists of the furnishing and installation of an Ethernet Managed Field Switch in the CCD controller cabinets. The switch will be furnish by the Contractor as part of the Traffic Signal Controller Cabinet at the locations as shown in the plans.

Subsection 614.08 shall include the following:

The Ethernet Managed Field Switch installation is hereby added to the Standard Specifications and Ethernet Switch complies with the following specifications:

General System Requirements –The Ethernet Managed Field Switch, or equivalent with the Industrial Ethernet Managed Field Switch, will be a Garrettcom Magnum Ethernet Managed Field Switch comprising of the following four (4) parts:

- 1) 6KQ-24VDC base unit with four 10/100 copper ports in slot A (without 24VDC power supply).
- 2) 6KQ-RJ45 module with four 10/100 copper ports in slot B.
- 3) 6KQ4-MLC module with four 100Mb 2km multi-mode LC fiber ports in slot C.
- 4) 6KQ-BLNK blank cover for 1 unused module in slot C.

The field switch also meets the following requirements:

- May be configured with a variety of 10/100/1000 Mb fiber and copper port connector types -16 total ports maximum.
- Heavy duty and environmentally hardened fully enclosed metal case with advanced thermal design used as a heat sink (no fan).
- Dual LEDs for all-around status viewing.
- Wire speed filtering and forwarding across all ports - 802.3x flow control, 802.1p priority packet processing, self-learning 4K-node address table, large 240KB packet buffers for 10/100 and 120KB for 1000Mb.

The unit is configured as a minimum:

Filtering/Forwarding Rate Performance:

- Ethernet (10Mb):14,880 pps
- Fast Ethernet (100Mb): 148,800 pps
- Gigabit Ethernet (1000Mb): 1, 488,000 pps
- Switching Processing Type: Store and Forward with IEEE 802.3x full duplex flow control, non-blocking
- Data Rate: 10Mbps, 100Mbps and 1000Mbps
- Address Table Capacity: 4K node, self-learning with address aging
- Packet buffer size: 240KB for 10/100 and 120KB for 1000Mb
- Latency: 5 μ s + packet time (100 to 100Mbps); 15 μ s + packet time (10 to 10 Mbps, and 10 to 100Mbps)
- Throughput with 12 10/100 and 2Glink max.- 4.76M pps (Transmit)
- Back plane- 2.66 GB/s per slot LEDs:

-2-

**REVISION OF SECTION 614
ETHERNET MANAGED SWITCH**

- Per Port (one set at the port, one set on swivel top on right side)
- LK: Steady ON when media link is operational
- ACT: ON with receiver port activity
- FDX/HDX: ON = Full-Duplex Mode; OFF = Half-Duplex Mode
- 100/10: ON = 100Mbps speed; OFF = 10 Mbps

Network cable connectors:

- 1000Mb fiber ports: all standard Gb SFP Transceiver types supported
- 1000Mb copper ports: 10/100/1000Mb auto-negotiating, Cat5e & 6 UTP/STP
- 100Mb Copper and PoE: Category 5 UTP/STP; 10 Mb: Cat. 3, 4, 5 UTP/STP
- 100 Mb Fiber ports connector options: multi-mode FX-MTRJ, LC, ST, SC; Single-mode 15Km LC, 20Km SC and ST, and 40 Km “long reach” single-modes SC.

Operating Environment:

- Ambient Temperature: -40° to 140° F (-40° to 60°C)

Alarm Relay Contacts:

- One NC indicating internal power, one NC software controllable

DC Power Supply:

- 24VDC Power Input nominal (range 18 to 36VDC)
- Power Consumption: 35 watts worst case (for a fully loaded fiber model); 12 watts typical (for a small 4 port copper-only model)

Vertical mounting normal:

- Suitable for wall or DIN-Rail mounting

Subsection 614.13 shall include the following:

The Ethernet Managed Switch installation will be tested in accordance with this specification or as directed by the Engineer. Installation shall include all wiring for hook-up, related labor, material, and all necessary documentation of testing.

Subsection 614.14 shall include the following:

Installation of the Ethernet Managed Field Switch will not be measured and paid for separately, but shall be included in the cost of Traffic Signal Controller and Cabinet.

END OF SECTION

**REVISION OF SECTION 614
UNINTERRUPTED POWER SUPPLY SYSTEM**

Section 614 of the Standard Specifications is hereby revised for this project as follows:

Subsection 614.08 shall include the following:

The double conversion uninterruptible power supply system (UPS) is a fully integrated system within the new controller cabinet and shall provide emergency battery power to the traffic signal controller. The UPS shall conform to the following specifications:

Operation:

The UPS system shall be capable of producing a fully regenerated, conditioned, pure sine wave AC. The online operational mode shall be continuous to all loads. It shall incorporate a high frequency Pulse-Width Modulated technology and shall use an input rectifier, charger, battery and inverter in a single board configuration. The UPS double conversion UPS shall provide a clean, pure AC sinewave output at all times with a voltage input variation of 85VAC to 145VAC while providing 120VAC to the connected load at all times. The UPS shall be capable of operating in the voltage range of 85VAC to 135VAC without using the batteries and always provide a regulated output to the protected loads.

The Input rectifier shall be rated at 2.5 times the output rating of the inverter.

The Inverter circuit shall be in continuous operation at all times (constant duty). The inverter shall be rated for 100% duty cycle and simultaneously fed from the rectifier and battery to eliminate any switching to battery or transitions during power fluctuations or power interruption. The inverter's output shall be pure clean sine wave with an efficiency of up to 85%.

The constant duty operation shall be rated in total watts. This will enable the traffic UPS to support any combination of signal heads whether Incandescent, LED or Neon, by any manufacturer, regardless of power-factor.

The UPS shall be capable of operating from a generator source without the need for over-sizing the UPS system. During operation from a generator source, the UPS shall operate in a normal fashion and provide filtered and regulated power with or without automatic input/output frequency synchronization. Upon excessive generator frequency drift, the UPS shall compensate through regeneration and supplying both continuous frequency and voltage regulation to the protected load.

The UPS shall be capable of glitch ride through capabilities and provide a seamless output to the connected load during this anomaly without the use of the batteries.

The UPS shall be capable of providing an overload output rating of 120% for 60 seconds, 150% for 10 seconds to any combinations of signal types whether Incandescent, LED or Neon during inrush or overload conditions.

The UPS shall have an internal static bypass that will transfer to line power if over load exceeds 150% for more than 5 sec. This bypass will maintain the load until this overload has cleared.

-2-

**REVISION OF SECTION 614
UNINTERRUPTED POWER SUPPLY SYSTEM**

The UPS shall have a separate Neutral detecting circuit that shall monitor loss of utility neutral and completely disconnect any input source to the UPS system.

The UPS shall have an input back feed relay operating in series with the Neutral monitoring circuit.

Upon loss of utility power, the UPS inverter shall continue to provide seamless pure sine-wave AC from the batteries without switching, transfer or changing its' operating status. The UPS will use the battery mode in '0' ms. This will insure that the UPS provides pure sine wave power under all conditions, at all times without interruption.

The UPS will continue to provide generated AC from the inverter until the batteries are depleted.

When the batteries have been depleted, the UPS will ensure upon the return of Utility Power that the UPS will restart automatically and provide regenerated AC to the protected equipment and allow the equipment to resume normal operation.

The UPS shall be capable of operating in a full regenerated, power-conditioning mode with depleted batteries or failed batteries. The regenerative power conditioning will ensure that there will be regulated and conditioned pure AC power to the equipment. This regenerative mode will provide extended brown-output protection with wide input line regulation, noise filtering and surge protection.

The UPS shall operate in an uninterruptible regenerative on-line mode during flash or normal signal operation.

The UPS shall be rated at Unity Power Factor. The output VA and Watts rating shall be equal on the output at all times.

The UPS shall be capable of COLD starting without AC present and provide AC power to the load.

The UPS shall be capable of self-diagnostics during start up or with the use of the front panel TEST button.

The UPS case shall be constructed from .064 aluminum and carbon steel.

The UPS input and output connections shall be Anderson Power Pole quick lock connector to eliminate exposed terminals or connections.

The UPS to bypass interconnect harness shall be reversible with matching Anderson Power connectors that will prevent risk of shock, or damage to the connected equipment.

The UPS shall be capable of Hot-Swapping the batteries or battery bank, without shutting down the UPS.

The UPS shall be capable of being Hot-Swapped during normal operation when used with the external Hot Swap Bypass. The UPS may also be shut-off with the Hot Swap Bypass in place without loss of AC to the loads.

-3-

**REVISION OF SECTION 614
UNINTERRUPTED POWER SUPPLY SYSTEM**

The UPS shall be capable of providing a replaceable relay card with relay output contacts for AC fail, Inverter ON, Low Battery, Battery Fail, Bypass and Alarms.

The UPS relay card may be replaced with an SNMP card for SNMP communications and information.

The UPS shall provide a programmable Dry Relay output for flash.

The contacts shall be provided in N/O and N/C positions. The delay timer shall be a maximum of 10 hours.

The timer shall be front panel mounted.

The Timer dial shall be 4.7 inches in circumference.

The timer shall have a scale in increments of 1s to 10seconds. This scale can be changed to indicate 1 minute, to 10 minutes or a maximum scale of 1 hour to 10 hours.

The scale shall be controlled by two (2) separate dip switches on the timer face.

The timer shall indicate using a flashing RED LED that the timing function is operating.

The timer shall use a steady RED LED to indicate that the timing is now completed

The timer shall count in a down mode to '0' from the preset time indicated on the scale.

The LED indicators shall provide status for AC line, UPS Battery Mode, Charging, Low Battery, Fault, Bypass, Percentage of Load and Battery Charge.

The Event counter and Hour meter may be rest to '0' using separated buttons.

The UPS shall have a battery charger rated at 200 watts @ 36VDC with an optional of 400 watts.

This charger shall be completely separate from the rectifier/inverter included with the main UPS board.

The UPS chargers may be used in a parallel configuration for increased charger ratings.

The UPS uses a redundant internal 1 amp charger that will continue to charger the batteries if the separate board charger fails.

The UPS may be used with redundancy in mind with the use of the Dual Hot Swap Option.

That will provide a secondary UPS source in less than 20ms. The Secondary UPS may be connected to the alternate input of the Hot Swap Bypass

The Flash programming shall be a simple and field programmable without the use an external connected device such as a laptop or computer.

The Hot swap Bypass shall allow the UPS to be removed or installed at any time during normal load operation.

The UPS shall include standard graphical real time software and connection cable.

-4-

**REVISION OF SECTION 614
UNINTERRUPTED POWER SUPPLY SYSTEM**

The UPS shall be capable of sending programmable system alarms to the Econolite “icons” Traffic Management System.

Physical Description:

The UPS shall consist of 3 major components - the Main board Rectifier/Inverter, charger and control board.

The Main Board shall consist of a True-Sine-Wave constant duty high frequency inverter utilizing High-Frequency Pulse-Width Modulated technology.

The Input Rectifier shall be rated for the total wattage output rating of the UPS including the 150% overload and the charger rating. The inverter shall be a high efficiency constant duty design with an efficiency of 83%. The inverter shall include its own static bypass which provides an alternate AC path during overload and or Inverter alarm conditions.

The heat-sink shall be a continuous aluminum extrusion design with plenum directed airflow cooling. The 12VDC dual stage cooling fans shall be variable speed controlled by the logic board.

The charger portion shall be a 3 stage Hysterisis .5 amp, 36 or 72VDC charger with temperature compensation. The supplementary charger is a parallel design rated for 200, 500 and 1000 watts.

The Electronic Control board shall monitor the Rectifier and Inverter functions. It shall also provide the overall control of all the UPS functions and or operational capabilities.

Mounting Configuration:

The UPS shall be shelf mounted or rack mounted per the documents. Shelves and cabinets shall be supplied by others. Where rack mounting is required, the 170 style mounting method shall be 19” rack mount. Rack mounting ears shall be removable.

A separate standalone NEMA Traffic cabinet may be supplied if required in the plans and specifications. 4 rubber feet shall be installed on the bottom of the unit for shelf mounting.

Battery System:

The batteries shall be comprised of a quantity of three (3), high temperature, deep cycle (45AH) batteries which have been proven under extreme temperature conditions. The battery system or configuration shall consist of one string. Each string shall be 36 VDC. The batteries shall be provided with the appropriate interconnect cables. The battery cables shall have a minimum conductor size rating of #10.

The battery cable shall consist of a quick release Anderson connector rated at 25 amps. For the purpose of safety, the connector shall have recessed pins and keyed interlock to prevent reversal of connection or separation.

-5-
REVISION OF SECTION 614
UNINTERRUPTED POWER SUPPLY SYSTEM

Battery construction shall be of a polycarbonate high temperature design combined with high, pure lead content with internal resistance of .0028 ohms and a high impact poly case construction, to withstand high vibration and shock. The connections shall be of stainless steel 3/8 stud, with 3/8 stainless nut and locking washer. Removable lifting handle shall be standard.

The batteries shall also meet the following characteristics:

| | |
|----------------------------|--|
| Nominal voltage: | 12VDC |
| Capacity@ 25C: | 45AH |
| Approx. weight: | 13.5Kg |
| Internal Resistance: | 9.5 mOhms |
| Dimensions: | 197mm x 165mm x 170mm (7.76 x 6.50 x 6.69) |
| Capacity (10hr rate): | 75c-112% 65c-108% 55c-105% 25c-100% 0c- 85% -15c- 65% |
| Self Discharge: | 3 months 91% capacity remaining 6 months 82% capacity remaining 12 months 65% capacity remaining |
| Operating Temperature: | -15c to +75C |
| Float Voltage: | 13.5 to 13.80 |
| Cyclic charging voltage: | 14.5 to 14.90 |
| Maximum charge current: | 12A |
| Terminal material: | Copper |
| Maximum discharge current: | 400A (5 sec) |

The system must be 36 volt DC maximum (no exception).

Electrical Specifications:

The unit shall meet the following electrical specifications:

| | |
|----------------------|--|
| Design: | Double Conversion true on line. |
| Nominal input: | 110, 115 & 120v AC single phase dip switch selectable. |
| Input Voltage Range: | 80v to 140v AC |
| Input frequency: | 50/60hz (47 to 63) |
| Efficiency: | 83 % |
| Input configuration: | 3 wire with ground |
| Input Protection: | 15 amp re-settable breaker (on UPS 700) |

-6-
REVISION OF SECTION 614
UNINTERRUPTED POWER SUPPLY SYSTEM

| | |
|----------------------------------|--|
| Input Current: | 10.4 amps (includes charger) (on UPS 700) |
| Power Rating Continuous: | 700 watts, 1400watts, 2100 watts |
| Output Current: | @ 700 watts 5.8 amps / 11.6 @1400/ 17.7@2100 |
| Output regulation: | +/- 3% with 100% resistive load |
| Output regulation w/low battery: | +/- 3% with 100% resistive load |
| Output Voltage: | 120v AC |
| Output Wave Form: | Pure sine wave |
| Harmonic Distortion: | 3% Linear Load; 5% Non Linear Load |
| Dynamic Response: | +/- 5% RMS for 100% step load change 1 ms recovery time |
| Overload Capability: | 120% for 60 sec 150% watts for 10 sec |
| Charger: | 200 watt 36VDC UPS 700, 72VDC on UPS 1400 Parallel 400, 1000 and 2000 watt. |
| Surge: | ANSI-C62.41 |
| Fault Clearing: | Current Limit and automatic to bypass |
| Short Circuit protection: | Output Breaker / Fuse, then shut down |
| Load Power Factor: | 6 leading to .6 lagging |
| Output Connection: | Anderson Power Pole Connector 6 pin keyed. |
| DC Connection: | Anderson 50 amp Keyed Recessed connector |
| Recognition: | UL Recognized & IEE 587 / C62.41 on main UPS board |

Mechanical:

The UPS shall meet the following physical dimensions:

For 700 W UPS:

| | |
|---------|------------------------------|
| Size: | 6.00" H x 10.5" D x 15.15" W |
| Weight: | 18 lbs |

The enclosure shall be constructed of 0.064 Carbon steel and aluminum. The enclosure shall be painted with powder coat paint with a minimum of 1.5 mil thickness.

Environmental:

The UPS shall meet or exceed NEMA temperature standards from -40c to + 74c.

Communications, Control & Diagnostics

LED indicators shall be provided for line monitoring, battery mode, charging, low battery, fault / bypass load level, battery level and ground fault. Manual test functions shall be available for alarm function, low battery, battery fail, bypass and overload. An RS 232 port with communication software shall be provided for real time UPS operational status in place of a relay status card when required.

-7-
REVISION OF SECTION 614
UNINTERRUPTED POWER SUPPLY SYSTEM

The relay status card shall have the following I/O via contact closure:

1. Bypass ON
2. AC fail or out of tolerance.
3. AC normal or in tolerance.
4. Inverter is operating (ON)
5. Battery low
6. Battery failed or bad
7. UPS general alarm
8. Ground (logic)
9. Apply 6 to +25VDC
10. between pin 9 and 10, will shut the UPS down

Options:

The UPS must be able to accept the following future options

- SNMP/WEB monitoring.
- 24/7 Adjustable perpetual timer.
- Generator input option for hot swap bypass switch.
- Rack mount hot swap bypass switch.

In place of the relay card, an SNMP card can be installed that shall support TCP/IP, UDP, SNMP, and HTTP protocols and shall provide the SNMP MIB for UPS monitoring and UPS status. Remote access to UPS real time information including unit identification, data logging and UPS status in real time shall also be provided on a by unit basis. It shall be possible to use Microsoft Internet Explorer for remote viewing of the following:

1. UPS load
2. Battery Charger status
3. UPS operation Normal/Alarm
4. Input Voltage
5. Output Voltage
6. Battery Voltage
7. UPS Temperature
8. UPS information logging
9. Remote UPS battery testing.
10. Send output email if UPS status has changed
11. Built in reset with panel mounted led indicators for SNMP status.

The SNMP card shall have the following status LEDs:

| | |
|---------|-----------------------------|
| LED(1) | Green LED: Status receiving |
| Yellow: | Data Transmitting |
| LED(2) | Green: SNMP connecting |
| Yellow: | SNM P functioning |

-8-
REVISION OF SECTION 614
UNINTERRUPTED POWER SUPPLY SYSTEM

The optional 24/7 timer shall be integral to the UPS. It shall include a DB9 connector to provide the connection and programming to the timer. This timer shall be programmable for any number of flash delays related to the time of day. It allows the complete flexibility of flash delay or skipping the flash during that particular event related to traffic flow and even holidays. The time shall have the follow features:

1. 7 days, 24 hrs Flash delay timing.
2. Perpetual Clock.
3. Maximum of 31 setting per day.
4. Timing resolution to the minute.
5. 4 Possible commands per event.
6. Real-time operation, editing functions will not interrupt the unit's functions.
7. J-Tag port for instant preload of complete 7-day schedule file.
8. SPDT 10 amp 240VAC /24VDC ratings.
9. Input Voltage 110 to 240VAC or 24VDC unregulated supply.
10. Plus! Capable of scheduling for holidays or specific year/dates.
11. Capable of operating at 2400 baud micro-modem for direct phone connection
12. Capable of operating at 1200 to 230,000 baud rate on a serial port.
13. Capable of log retention

An optional generator input shall be available for the UPS.

Reliability:

Calculated MTBF shall be 120,000 hours based on component ratings. When bypass switch is installed, system MTBF shall increase to 160,000 hours.

Hot Swap Bypass Switch:

A hot bypass switch shall be provided and wired to function within the UPS system. The bypass switch shall have the following characteristics:

| | |
|------------------|---|
| Bypass Rating: | 30 amps maximum |
| Bypass Transfer: | Automatically to line in 20ms, '0' crossing at full load |
| Control: | Rocker On/Off switch indicating 'Auto' and Bypass |
| Relays: | AC internal Load relay at 'Zero Crossing' with parallel function DC relay for interlocking and protection failsafe mode to N/C for AC power direct to load when failure occurs or in Bypass position. |
| Protection: | Internal Snubber circuit for spike attenuation during transfer at 'Zero' crossing. Internal fuse required. |
| Connections: | Flush mounted Anderson Power connector. With locked and keyed. |
| Indicators: | LED for Line Available, Bypass, Ups On Line, UPS Available. |
| Dimensions: | 7.5 x 5 x 2.5 |
| Weight: | 1.4 lbs |

-9-

**REVISION OF SECTION 614
UNINTERRUPTED POWER SUPPLY SYSTEM**

Warranty:

A standard (2) two year manufacturer warranty shall be provided for all electronic components. All batteries shall carry a one year warranty.

Subsection 614.13 shall include the following:

Emergency Vehicle Traffic Signal Priority Control System units shall include a four-channel card and the number of detectors as shown on the plans. Emergency Vehicle Traffic Signal Priority Control System shall be measured and paid by the number of intersections at which the system is installed. The item shall include all labor, materials, and ancillary hardware required to provide a fully functioning system to the satisfaction of the Engineer.

Subsection 614.14 shall include the following:

Traffic signal uninterrupted power supply system installation will not be paid for separately, but shall be included in the cost of the Traffic Signal Controller and Cabinet.

END OF SECTION

**REVISION OF SECTION 614
EMERGENCY VEHICLE TRAFFIC SIGNAL PRIORITY CONTROL SYSTEM**

Section 614 of the Standard Specifications is hereby revised for this project as follows:

Subsection 614.08 shall include the following:

System Description:

The emergency vehicle traffic signal priority control system shall enable designated vehicles to remotely cause the traffic signal controller to advance to and/or hold a desired traffic signal display by using existing controller functions. The control shall be activated at a minimum distance of 548.6M (1,800 feet) along an unobstructed "line of sight" path. The control shall not terminate until the vehicle is within 12.2M (40 feet) of the detector or at the intersection.

The system shall consist of the following components:

- A. Vehicle Emitter which shall be mounted on the emergency vehicle and shall transmit optical energy signals only in the forward direction. If the municipality presently uses optical preemption, the emitters shall be of the same manufacture currently used by the City and County of Denver Fire Department.
- B. Phase Selector (minimum 2 channels) which shall cause the signal controller to advance to and/or hold the desired traffic signal display for the emergency vehicle. A pre-emption system chassis shall house two phase selectors.
- C. Optical Detector which shall be mounted on or near a traffic signal and shall receive the optical energy signals generated by the Vehicle Emitter.
 - a. Detector (Type A), 1 Direction, 1 Channel
 - b. Detector (Type B), 2 Direction, 1 Channel
 - c. Detector (Type C), 2 Direction, 2 Channel
- D. Detector Cable (Optical).

System Operations:

- A. The operating sequence shall be initiated when the optical detector receives the required optical energy signal from the Emitter.
- B. The phase selector shall cause the traffic signal controller to advance to and/or hold the desired traffic signal display for the emergency vehicle.
- C. The phase selector shall cause the controller to advance to and/or hold the desired traffic signal display even if the optical energy signals cease before the desired display is obtained.
- D. The phase selector shall allow the traffic signal controller to resume normal operation within ten seconds after optical energy signals cease if the optical energy signals cease after the desired traffic signal display is obtained.
- E. The phase selector shall not respond to optical energy signals from an emergency vehicle if it is already processing optical energy signals from another emergency vehicle.

-2-

**REVISION OF SECTION 614
EMERGENCY VEHICLE TRAFFIC SIGNAL PRIORITY CONTROL SYSTEM**

System Components:

A. Vehicle Emitter:

The emitter assembly consists of an emitter and power supply and an emitter control switch assembly. The emitter assembly is mounted on a vehicle and produces a flashing optical signal when in operation. The following shall apply to the vehicle emitter:

1. Shall operate on ten to fifteen volts DC input voltage, but shall not be damaged by input voltage surges up to twenty-five volts DC.
2. Shall be controlled by a single on/off switch that requires no other adjustments by the operator. The on/off condition shall be indicated by a light located adjacent to the switch.
3. Shall be automatically disabled or de-activated by one or a combination of the following: seat switch, emergency brake switch, door switch, and transmission safety switch.
4. Shall operate over an ambient temperature range of minus 34O C to plus 60O C (minus 30O F. to plus 140O F.)
5. Shall operate in 0 to 95 % humidity.
6. Shall be a pulsed optical energy source with a controlled repetition rate.
7. Shall not generate voltage transients on the battery input line which exceed battery voltage by more than four volts.
8. Shall produce optical energy in a cone of not more than 90 degrees horizontal and not more than 30 degrees vertical. The detectors and/or phase selector shall not sense a pre-emption signal from an emitter outside this cone.

B. Optical Detector:

The optical detector receives the high intensity optical pulses produced by the emitter.

These optical energy pulses are transformed by the detector into appropriate electrical signals which are transmitted to the phase selector. The optical detector is mounted at or near the intersection in a location which permits an unobstructed line of sight to vehicular approaches. The units may be mounted on signal span wires, mast arms or other appropriate structures. The following shall apply to the optical detector:

1. Shall produce optical energy in a cone of not more than 90 degrees horizontal and not more than 30 degrees vertical. The detectors and/or phase selector shall not sense a pre-emption signal from an emitter outside this cone.
2. Shall be of solid state construction.
3. Shall operate over an ambient temperature range of minus 34O C to plus 60O C. (minus 30O F. to plus 140O F.)
4. Shall have internal circuitry potted in a semi-flexible compound to ensure moisture resistance.
5. Shall operate in 0 to 95 % humidity.
6. Shall have a cone of detection of not more than 13 degrees. The detector and/or phase selector shall not sense a pre-emption signal from an emitter outside this cone.

C. Phase Selector:

The phase selector supplies power to and receives electrical signals from the optical detector. When detector signals are recognized as a valid call, the phase selector causes the signal controller to advance to and/or hold the desired traffic signal display. This is accomplished by activating the pre-empt input to the controller.

-3-

**REVISION OF SECTION 614
EMERGENCY VEHICLE TRAFFIC SIGNAL PRIORITY CONTROL SYSTEM**

The phase selector is capable of assigning priority traffic movement to one of two channels on a first-come, first-serve basis. Each channel is connected to select a particular traffic movement from those normally available within the controller. Once a call is recognized, "commit to green" circuitry in the phase selector functions so that the desired green indication will be obtained even if optical communication is lost. After serving a priority traffic demand, the phase selector will release the controller to follow normal sequence operation. The following shall apply to the phase selector:

1. Shall include an internal power supply to supply power to the optical detectors.
2. Shall have minimum two-channel operation with the capability of interfacing with an additional phase selector for expansion of channels of operation.
3. Shall have adjustable detector range controls for each channel of operation, from 12M (40 feet) to 548M (1800 feet).
4. Shall have solid state indicator lights for power on and channel called.
5. Shall operate over an ambient temperature range of minus 34O C to plus 60O C (minus 30O F. to plus 140O F.)
6. Shall operate in 0 to 95 % humidity.

D. Detector Cable (Optical):

The following shall apply to the detector cable:

1. 3-Conductor cable with shield and ground wire.
2. AWG #20 (7x28) stranded.
3. Individually tinned copper strands.
4. Conductor insulation: 600 volt, 75 deg. C (167O F.).
5. 1 Conductor-yellow; 1 Conductor-blue; 1 Conductor-orange.
6. Aluminized Mylar shield tape or equivalent.
7. AWG #20 (7x28) stranded uninsulated drain wire
8. DC resistance not to exceed 11.0 ohms per 305M (1000 feet).
9. Capacitance from one conductor to other two conductors and shield not to exceed 157pf/M (48pf /ft.).
10. Jacket: 600 volts, 80 deg. C (176O F.), minimum average wall thickness - 1.14mm (.045").
11. Finished O.D.: 7.62mm (0.3") max.

System Interface:

System shall be capable of operating in a computerized traffic management system when appropriate interfacing is provided by the computer supplier.

General:

The Contractor shall furnish the manufacturer the phasing diagrams indicating controller sequence and timing.

The Contractor shall secure from the manufacturer a guarantee for the equipment for a period of sixty (60) months, which time shall commence from the date of delivery. Manufacturer shall certify upon request that all materials furnished will conform to this specification. The manufacturer or his designated representative shall be responsible for determining and setting all required range and emitter intensity for the emergency vehicle operation.

-4-

**REVISION OF SECTION 614
EMERGENCY VEHICLE TRAFFIC SIGNAL PRIORITY CONTROL SYSTEM**

Construction Methods:

All equipment except the vehicle emitter assembly shall be installed and wired in a neat and orderly manner in conformance with the manufacturers' instructions. The vehicle emitter assembly shall be delivered to a designated City representative.

Installation of the vehicle emitter assembly shall be the responsibility of the City and County of Denver Fire Department.

Traffic signals owned and maintained by the State that have optical pre-emption equipment owned and maintained by the town shall have an Auxiliary Equipment Cabinet (AEC) attached to the controller cabinet. The optical pre-emption equipment shall be housed in the AEC. Traffic signals owned and maintained by the town do not require an AEC to house the pre-emption equipment.

Detector cables shall be continuous with no splices between the optical detector and the AEC.

Detector locations shown on the plan are for illustration purposes only. Exact location shall be determined by the contractor or the designated representative for the best possible line of sight.

- Controller "D" harness and adapter.
- Pre-emption termination panel with terminal block and relay bases.
- Pre-emption disconnect switch, mounted on the emergency switch panel (on inside of cabinet door).
- Pre-emption test buttons, mounted on the pre-emption termination panel.

All connections from the phase selector to the "D" harness and to the cabinet wiring shall be made at the termination panel. The termination panel shall have AC+ Lights, AC-, and a switched logic ground. The switched logic ground feeds all the pre-empt inputs to the phase selector. When switched off by the pre-emption disconnect switch, the traffic controller shall not be affected by preempt calls from the optical pre-emption system. A minimum of two test buttons shall be provided. If there are more than two pre-empt runs, a button for each shall be installed. A chart or print out indicating the program steps and settings shall be provided along with the revised cabinet wiring diagrams.

Test the Pre-emption System According to the following Guidelines:

1. Notify the system owner/user, such as the Municipal Fire Chief or City Traffic Engineer, of the scheduled inspection
2. Request a fire department representative and an emergency vehicle, which has an emitter to conduct the test. If not available, the contractor shall provide an emitter.
3. In the presence of the Engineer and the municipal representative, test each preempted approach with the emergency vehicle. Test the following items of the system:
 - a. Confirm that the emitter activates the phase selector and the phase selector activates the correct pre-emption input to the controller.
 - b. Confirm adequate range. The traffic signal must be pre-empted to green sufficiently in advance of the emergency vehicle arrival. The vehicle emitter shall initiate pre-emption at a minimum distance of 548.6M (1800 feet).
 - c. Confirm there are no false calls. Keep the emitter active as the emergency vehicle passes through the intersection. No other optical detectors shall sense the strobe.
4. Document the test. Provide the Engineer and, upon request, the municipality copies of the test results.

-5-

**REVISION OF SECTION 614
EMERGENCY VEHICLE TRAFFIC SIGNAL PRIORITY CONTROL SYSTEM**

If a malfunction is found or the system needs adjustment (such as range, emitter intensity, or detector location), schedule a follow-up test. Repeat the above steps for all approaches that did not pass.

All adjustments such as emitter intensity, phase selector range, sensitivity, detector placement, shall be made at the intersection by the contractor so that the optical pre-emption operates correctly with other major manufacturers' equipment currently owned by the town.

Subsection 614.13 shall include the following:

Emergency Vehicle Traffic Signal Priority Control System units shall include a four-channel card and the number of detectors as shown on the plans. Emergency Vehicle Traffic Signal Priority Control System shall be measured and paid by the number of intersections at which the system is installed. The item shall include all labor, materials, and ancillary hardware required to provide a fully functioning system to the satisfaction of the Engineer.

Subsection 614.14 shall include the following:

| Pay Item | Pay Unit |
|--|-----------------|
| Emergency Vehicle Traffic Signal Priority Control System | Each |

END OF SECTION

**REVISION OF SECTION 614
TRAFFIC SIGNAL POLES – GENERAL**

Section 614 of the Standard Specifications is hereby revised as follows:

Subsection 614.08 (g) shall include the following:

This work is for the installation of the traffic signal poles. Traffic signal span wire poles (imbedded steel poles) will be furnish and install by the Contractor at locations as shown on the plans or as directed by the Engineer. The traffic signal span wire poles shall be painted dark olive green in conformance with Federal Specification No. 14056.

Mast arm traffic signal poles, traffic signal light poles, pedestal poles and the mast arms will be furnished and installed by the Contractor at locations as shown on the plans or as directed by the Engineer. The mast arm traffic signal poles, light poles and the mast arms will be the type manufactured by Valmont in accordance with the City and County of Denver's standards and specifications. General specifications of the imbedded steel poles, traffic signal light poles, and traffic signal poles with mast arms are as follows:

TRAFFIC SIGNAL POLES: All traffic signal poles (imbedded poles, traffic light poles and traffic poles with mast arms) shall conform to City and County of Denver's Traffic Standard Details 16.1.3 and 16.1.9 to 16.1.12. Traffic Signal Pedestal Poles shall conform to the requirements of the City and County of Denver's Traffic Signal Standard Detail 16.1.13.

The Contractor shall furnish and install a 5300 Lumens LED luminaire as shown on the plans or as directed by the Engineer. The LED luminaire shall be in accordance with the City and County of Denver's specifications and Sections 613 – LIGHTING. The luminaire shall be installed on the traffic signal poles with a 10 foot luminaire arm as per the City and County of Denver's Traffic Standard Details 16.1.3, and 16.1.9 to 16.1.12.

FINISH: All traffic signal mast arm poles shall be finish in accordance with Valmont finish process F540 or equal – galvanized, epoxy primer and powder coated in accordance with the following specifications:

PAINTING: All traffic signal mast arm poles shall be powder coated in accordance with the following specifications:

General:

Super Durable Powder Coating: The super durable powder coating shall consist of a Urethane or Triglycidylisocyanurate (TGIC) Polyester Powder, and provide a minimum of 3 times the gloss retention, color retention and ultraviolet light (UV) resistance as standard powder coatings. Color shall be dark olive green, in conformance with Federal Specification No. 14056.

Surface Preparation:

The exterior steel surface shall be blast cleaned to Steel Structures Painting Council Surface Preparation Specification No. 6 (SSPC-SP6) requirements utilizing cast steel abrasives conforming to the Society of Automotive Engineers (SAE) Recommended Practice J827. The blast method is a recirculating, closed cycle centrifugal wheel system with abrasive conforming to SAE Shot Number S280.

-2-

**REVISION OF SECTION 614
TRAFFIC SIGNAL POLES – GENERAL**

Interior Color:

Interior surfaces (pole shafts only) at the base end for a length of approximately 2.0' shall be mechanically cleaned and coated with a zinc rich epoxy powder. The coating shall be electrostatically applied and cured in a gas fired convection oven by heating the steel substrate to a minimum of 350 degrees Fahrenheit and a maximum of 400 degrees Fahrenheit.

Exterior Coating:

All exterior surfaces shall be coated with Urethane or Triglycidylisocyanurate (TGIC) Polyester Powder to a minimum film thickness of 2.0 mils (0.002"). The coating shall be electrostatically applied and cured in a gas fired convection oven by heating the steel substrate to a minimum of 350 degrees Fahrenheit and a maximum of 400 degrees Fahrenheit. The thermosetting powder resin shall provide both intercoat as well as substrate fusion adhesion that meets 5A or 5B classifications of ASTM D3359.

Packaging:

Prior to shipment, small poles shall be wrapped in 0.188" thick Ultraviolet inhibiting plastic backed foam. Larger poles shall be cradled in a 1.0" rubberized foam base.

Handling and Shipment:

Poles shall be handled in a manner that will preserve the overall appearance and prevent damage to the coating. The use of chains or cables for loading, unloading, or installing is prohibited. Only ¾ inch diameter or larger nonabrasive nylon rope or equivalent nylon belting will be used. Adequate hold-downs and appropriate blocking shall be utilized for shipping to prevent load movement and damage to the outer coating in transit. No handling should be allowed until "dry through" condition has been achieved with the coating.

Extra care will be taken not to damage the coating. Upon arrival of the poles at the delivery point, neither chains nor cables will be used to either unloading or installation of poles.

Procedure for Field Touch-Up:

The pole manufacturer will furnish extra paint, both primer and color coat, to satisfy the needs of field touch-up requirements, in the event of minor physical damage to the coating from handling or transit. Damaged area must be clean and dry before repair application. Field touch-up will be at the direction of the pole manufacturer or their authorized representative.

Subsection 614.14 shall include the following:

| Pay Item Pay | Unit |
|--|-------------|
| Traffic Signal-Light Pole Steel (1-XX Foot Mast Arm) | Each |
| Traffic Signal-Light Pole Steel | Each |

END OF SECTION

**REVISION OF SECTION 614
TELEMETRY (FIELD)**

Section 614 of the Standard Specifications is hereby revised for this project as follows.

Subsection 614.01 shall include the following:

This work consists of fan-out and termination of fiber optic (interconnect) cable at each controller cabinet locations as identified in the plans. This work also includes providing and installing all necessary fiber optic lateral cables and telemetry equipment including but not limited to optical splice closures, field patch panels, splice organizers, cables, pigtails/jumpers and labels.

Color-coded fibers and buffer tubes shall be used throughout the entire project. At the terminal points the jackets shall be stripped and the ends taped. Gel filled compound shall be removed using filled cable cleaner.

At every cabinet or optical closure, only the fibers identified in the plans to be spliced and/or connected to a patch panel or other internal device are required to be landed. All cut and unconnected fibers shall be sealed in a manner recommended by the fiber optic cable manufacturer and coiled neatly in a splice organizer.

The same color-coded pairs of fibers and/or wires shall be used throughout the entire project unless shown as otherwise in the plans. Gel filling compound shall be removed using filled cable cleaner.

Subsection 614.08 shall include the following:

Fiber Optic Patch Pigtail:

The fiber optic pigtail cables shall consist of MM fibers housed individually in protective jackets. Both ends of the cable shall be connected. Fiber optic patch cord cable shall be suitable for operation over a temperature range of -30 degrees to +60 degrees Celsius. Fiber optic patch cord cables shall be of length suitably long to be connected between the interconnect panel and the communications equipment (i.e. fiber optic transceivers). Patch cord couplings shall be compatible with termination points. Appropriate strain relief in the cabinet (through cable ties) shall be installed at a minimum of three locations. Sufficient slack shall be left to allow relocation of the equipment anywhere in the cabinet. The attenuation of a fiber optic patch cord cable after installation, not including the connector loss, shall not exceed 0.1 dB measured at 850 nm and 1300 nm.

Connectors:

The connector shall have a ceramic ferrule with a nickel-plated nut and body. The connector shall be an AT&T ST style compatible field mounted connector. The connector shall be compatible with a physical contact (PC) finish. All connectors shall be polished to a PC finish such that the return loss per mated pair of connectors is less than -25 dB. The return loss when the connector is mated with previously installed connectors shall be less than -18 dB.

The connector insertion loss shall not be greater than 0.20 dB (typical). The connector loss shall not vary more than 0.20 dB after 1000 repeated matings. Tensile strength shall withstand an axial load of 20 lb. with less than 0.20 dB change.

-2-

**REVISION OF SECTION 614
TELEMETRY (FIELD)**

Index matching fluids or gels shall not be used. The connectors shall be compatible with the optical fiber surrounding jacket and shall be installed on one end of the optical fiber in accordance with the manufacturer's recommended materials, equipment and practices. The connector shall be suitable for the intended environment and shall meet the following environmental conditions:

Operating Temperature: -40° to +80° C
Storage Temperature: -40° to +85° C

The connector loss shall not vary more than 0.20 dB over the operating temperature range. Connectors shall be protected by a suitably installed waterproof protection cap.

Miscellaneous Cabling:

Fiber optic patch cords shall be fiber optic jumper cable, duplex, ceramic ferrule, MM 62.5 nm, adaptable to AT&T ST style connectors, 2 meters in length, ITT Canon Model 161001-4020 or approved equal. Cable from fiber optic modem to Port 3 controller harness shall be 25-pin cable Model 44982G4 or approved equal. The Contractor shall deliver transceivers to the City's Traffic Signal Shop. Contact Joe Strauss (720) 865-4062 for coordination.

Optical Splice Closures:

Coyote Runt or Coyote Pup Type closures shall be provided for splicing lateral fiber optic cables to the main (backbone) fiber cable in all pull box locations that are identified in the plans. All closures shall include 1-Inch future port kit (part no. 8003408, Pre-Formed Line Products). The Coyote Runt Closure shall be used at locations with 3 fiber optic cables. In locations requiring more than 3 cables, a Coyote Pup Closure shall be installed.

Subsection 614.13 shall include the following:

Telemetry (Field) shall be measured by the total number of cabinets at which the interconnect cable is fanned out, terminated, connected, patch panels and fiber-optic interfaces installed. All labor and materials required to perform panel installations, provide in-cabinet strain relief, fan-out, cable termination and connection to the controller is considered included in the unit price for this item.

This item, therefore, includes the following:

1. All required in-cabinet cable ties and strain relief (including ancillary hardware and labor to complete);
2. All required fan-out kits, kit tools, ancillary hardware and labor to accomplish the fan-out at the cabinet;
3. All required pigtails and harness cables;
4. All required interconnect centers and fiber optic interface panels in individual controller cabinets as shown in the plans;
 - o All required termination enclosures (including specified features), connectors, adapters, jumpers, pigtails, patch cord cables, ancillary hardware and labor required to accomplish the cabinet termination;

-3-

**REVISION OF SECTION 614
TELEMETRY (FIELD)**

- All required optical splice closures;
- All other labor and material necessary to complete the item

All labor and materials necessary to complete this item shall be considered included in the unit price and will not be paid separately.

Subsection 614.14 shall include the following:

Payment will be made under:

| Pay Item | Pay Unit |
|-------------------|-----------------|
| Telemetry (Field) | Each |

END OF SECTION

**REVISION OF SECTION 614
LED OPTIC BLANK-OUT SIGNS**

Section 614 of the Standard Specifications is hereby revised for this project as follows:

Subsection 614.01 shall include the following:

This work consists of furnishing and installing a fully-functional LED Optic Blank-Out Signs.

Subsection 614.04 shall include the following:

General Description

- a) Sign shall be capable of displaying one or multiple messages.
These messages may be red, amber or bluish/green.
These messages may be displayed on one side or two.
The messages shall be formed by single or double rows of LED's.

Functional Description

- a) All messages shall be clearly legible, attracting attention under any lighting condition.
At full intensity, the signal will be highly visible anywhere within a 15 degree cone centered about the optic axis.
- b) The sign shall consist of:
 - a. Weatherproof housing and door.
 - b. LED's.
 - c. Transformers.
- c) All LED's will be T-1 $\frac{3}{4}$ (5 millimeters).
- d) LED's will have an expected lifetime of 100,000 hours.
- e) All LED's will be high in optical power.
They will be Agilent Technologies (HP) highest performance AlInGaP for the Red and Amber and Nichia's InGaN for the Bluish/Green and White.
- f) Operating wavelengths will be:
 - a. Red - 626 nm.
 - b. Amber - 590 nm.
 - c. Bluish/Green - 505 nm.
- g) Transformers shall be used to reduce the incoming 120 volts AC to the design DC voltage.
- h) The transformers shall contain Class A insulation and weatherproofing.
- i) The sign shall be capable of continuous operation over a range in temperatures from -35F to +165F (-37C to +75C).
- j) 50% Pulse Width Modulation Dimming available for improved nighttime visibility.

-2-

**REVISION OF SECTION 614
LED OPTIC BLANK-OUT SIGNS**

Aluminum Housing

- a) Housings shall be constructed of extruded aluminum. A flat aluminum panel shall be welded into the housing back for one-way signs.
- b) All corners and seams of one or two-way housings are heli-arc welded to provide a weatherproof seal around the entire case.
- c) Continuous full-length stainless steel hinges shall connect the housing and the extruded aluminum door.
- d) Signs shall have #3 stainless steel ¼ turn link-locks per door to tightly secure the door onto a gasket between it and the housing. Link-locks provide tool free access to the interior of the sign.
- e) Door gaskets shall be 3/16" x 1" neoprene to provide a weatherproof seal.
- f) The 0.125" extruded aluminum doors have one side removable to gain access to the sign face.
- g) Sign face shall be 0.080" aluminum or equivalent, and have the entire LED assembly mounted to it.
- h) Each door is fitted with a sun hood of 0.063" aluminum. Standard length is 6".
- i) The sign face will be protected by a polycarbonate, matte clear, lexan faceplate.
- j) Drainage shall be provided by four drain holes at the corners of the housing.
- k) Finish on the sign housing shall be two coats of exterior enamel applied after surface material is acid-etched and primed with zinc-chromate primer.

LED Message Modules

- a) The LED message module shall consist of the following components:
 - a. A rigid aluminum message plate.
 - b. High intensity LED's.
 - c. LED drive electronics.
- b) The LED's shall be mounted in panel via mounted fixing clips.
- c) Each LED shall be individually serviceable with spares included from the same batch to assure color uniformity upon replacement.
- d) Door panels shall be flat black to maximize legibility when activated.
- e) Electrical connections shall be made via barrier-type terminal strip.
- f) All fasteners and hardware shall be corrosion resistant stainless steel.

Warranty

All products will be warranted to be free of defects due to material and workmanship for a period of two (2) years.
Subsection 614.14 shall include the following:

| Pay Item | Pay Unit |
|-------------------|-----------------|
| LED Blankout Sign | Each |

END OF SECTION

**REVISION OF SECTION 614
CLOSED CIRCUIT TELEVISION CAMERA (TRAFFIC SURVEILLANCE)**

Section 614 of the Standard Specifications is hereby revised to include the following:

Subsection 614.01 shall include the following:

This work consists of the installation of a closed circuit television camera at the locations shown on the plans.

Subsection 614.08 shall include the following:

(m) Closed Circuit Television Camera (Traffic Surveillance)

Closed circuit television camera shall be the Panasonic WV-X6531N CCTV IP Camera or an equivalent IP (Ethernet) camera as approved by the City and County of Denver Traffic Engineering Services. The following accessories shall be provided for each IP camera: Panasonic PAPM3 Pole Mount Bracket; Panasonic POD9CW Dome Housing (wall mount); VOR-OS OUTSOURCE MIDSPAN 15/20W POE 802.3AF INJECTOR - 1 PORT and Altronix T2428100 24 VAC transformer.

Subsection 614.10 shall include the following:

The closed circuit television camera shall be installed in accordance with the details shown in the plans and in accordance with manufacturer's recommendations. The Contractor shall deliver the camera and accessories to the City and County of Denver's Traffic Operations

Department at 5440 Roslyn, Denver, Colorado at least 4 weeks prior to installation for the camera calibration and set up. The Contractor shall pick up the camera and shall install it at the proper location. The Contractor shall make arrangements for a City and County of Denver Traffic Operations' representative to be on-site to ensure proper installation.

Subsection 614.13 shall include the following:

Closed circuit television cameras will be measured by the actual number of closed circuit television cameras that are installed and accepted. All accessories shall not be measured separately.

END OF SECTION

Contract Control No. 2021-PROJMSTR-0000693

May 24, 2022

**REVISION OF SECTION 620
FIELD FACILITIES**

Section 620 of the Standard Specifications is hereby revised for this project as follows.

Subsection 620.02 shall include the following:

It is anticipated that the contractor will provide a Field Office for his own use. The cost for this field office will be included in the pay item for Mobilization.

Subsection 620.05 shall include the following:

Sanitary facilities shall be provided for the use of the Contractor and the City, including the City's Integrated Construction Contractor and consultants. The cost of sanitary facilities shall be included in the pay item for Mobilization.

Subsection 620.06 shall include the following:

The existing public right of way shall not be used for field office or material storage. Contractor shall coordinate with the Project Manager on the location for placement of the field office or material storage.

END OF SECTION

SECTION 623 LANDSCAPE IRRIGATION

Section 623 of the Standard Specification is hereby revised for this project as follows.

Subsections 623.01 through 623.31 are deleted and replaced with the following.

Part 1 - GENERAL

1.1 RELATED DOCUMENTS

Contract Drawings and general provisions of the Contract, including General and Supplementary Conditions.

City and County of Denver Engineering Division, Wastewater Capital Project Management Standard Construction Specifications, dated March 15, 2016.

2017 Transportation Standards and Details for the Engineering Division City and County of Denver Public Works

Wastewater Management Division – Standard Details (2015)

1.2 SUMMARY

This Section includes the requirements for the installation of an underground irrigation system including the following:

- Trenching, stockpiling excavation materials, refilling and compacting trenches.
- Complete irrigation system including but not limited to piping, valves, fittings, heads and wiring, sensors, backflow preventer(s), Automatic Irrigation Controller(s) and final adjustments to insure complete coverage.
- Water connections.
- Testing
- Replacement of unsatisfactory materials.
- Cleanup, inspections, and approval.

1.3 REFERENCES

- A. Conform to requirements of reference information listed below except where more stringent requirements are shown or specified in Contract Documents.
- 1) American Society for Testing and Materials (ASTM) - Specifications and Test Methods specifically referenced in this Section.
 - 2) Underwriters Laboratories (UL) - UL Wires and Cables
 - 3) National Sanitation Foundation (NSF) – Piping and backflow prevention.
 - 4) American Water Works Association (AWWA) Piping and backflow prevention.

1.4 QUALITY CONTROL

- A. Special Requirements.
- 1) Tolerances: Specified depths of mains and laterals and pitch of pipes shall be installed per the Contract Drawings and specifications.
 - 2) Compaction: Settlement of trenches is cause for removal of finish grade treatment, refilling, compaction, and repair of finish grade treatment.
 - 3) Coordination with Other Contractors: Protect, maintain, and coordinate work.

-2-

REVISION OF SECTION 623**LANDSCAPE IRRIGATION**

- 4) Damage to other Improvements: Contractor shall replace or repair grading, soil preparation, seeding, sodding, planting and/or new site features damaged during Work associated with installation of irrigation system at no additional cost to the City and county of Denver.
 - 5) Damage or Disturbance to the Existing “Private” Irrigation Components: Damage to existing components as a result of work being performed by the Contractor will require the Contractor to replace the damaged components in order to return the system to original condition, using product matching the original condition, at no additional cost to the City.
 - 6) Where reclaimed water supplies are available for irrigation, refer to contract documents for additional requirements.
 - 7) Water Delivery Interruption: When working on an existing irrigation system, the Irrigation Contractor shall contact the Project Manager and notify impacted property owners seventy-two (72) hours in advance of any water interruption that is anticipated. The maximum irrigation system interruption shall be no more than seventy-two (72) hours during the growing season. The contractor shall make all necessary provisions including material, equipment, labor, delivery and scheduling as required to complete all points of connection, upgrades, and improvements within seventy-two (72) hours.
 - 8) Watering: The Contractor is responsible for following all Denver Water rules and regulations for sod and seed establishment, available at <http://www.denverwater.org>. The Contractor shall post signage (available from Denver Water) per Denver Water guidelines in a visible location(s) on site indicating “IRRIGATION TESTING AND MAINTENANCE IN PROGRESS” when Work (establishment, construction or warranty) requires irrigation system operation between the hours of 10 AM and 6 PM.
 - 9) Permits: Work involving plumbing for installation of copper piping, ductile iron piping, backflow preventer(s), and related Work shall be executed by licensed and bonded plumber(s). The Contractor shall secure a permit at least forty-eight (48) hours prior to start of installation. Work involving high voltage electrical wiring, grounding and related Work shall be executed by licensed and bonded electrician. The Contractor shall secure a permit at least forty-eight (48) hours prior to start of installation.
- B. Pre-Construction Conferences and Site Meetings:
- 1) Contractor shall schedule and conduct a pre-construction conference to review, in detail, the quality control and construction requirements for equipment and materials used to perform the Work. Conference shall be scheduled ten (10) days prior to commencement of Work. All parties required to be in attendance shall be notified no later than seven (7) days prior to date of conference. Contractor shall notify qualified representatives of each party concerned with that portion of Work to attend conference, including but not limited to the Project Manager, City Owner’s Representative, Contractor’s Superintendent, and Installer.
 - 2) Prior to commencement of Work, Contractor shall schedule an on-site conference with Project Manager, Denver Forestry and all other parties designated by Project Manager to discuss tree protection requirements, marshalling locations, traffic control, and equipment access. The contractor shall provide a minimum of seven (7) day’s notice prior to date of conference.

-3-

**REVISION OF SECTION 623
LANDSCAPE IRRIGATION**

- 3) Contractor shall schedule on-site conferences the frequency of which is to be determined by the Project Manager and any other parties designated by the Project Manager to review project progress.
- 4) Contractor shall record Minutes of each conference and distribute to all parties in attendance within three (3) days of conference.

1.5 SUBMITTALS

Prepare and make submittals in accordance with conditions of the Contract prior to installation of any irrigation equipment:

Plumber's licensing and bonding information.

Material List: Submit a PDF file of complete list of materials, and cut sheets indicating manufacturer, model number and description of all materials and equipment to be used. Show appropriate dimensions and adequate detail to accurately portray intent of construction.

Shop Contract Drawings: If applicable, submit shop Contract Drawings for pumps, backflows and assemblies. Include plumbing and foundation/support systems if the installation differs from the manufacturer's recommended installation.

Mock Ups:

Valve assembly: Provide a completely built electrical valve assembly. This mockup, to include electric valve, service tee, lateral valve riser length as required for mainline depth, and male thread by spigot outlet adapter. The mock up may be incorporated into the work toward the end of the project.

Swing joints: Provide a pre-manufactured or constructed swing joint assembly for each detail shown (e.g. - quick coupler, rotors and pop-up spray head) or as directed by the Project Manager

Drain valves: Provide a mock up including the service tee, required fittings, and drain valve.

Other: Mock ups that may be requested by the Project Manager.

Operation and Maintenance Manual: Coordinate scheduling/precipitation instructions with the Project Manager, City Owner's Representative, Contractor's Superintendent. Submit one (1) digital copy in PDF format to the Project Manager including:

Winterization and spring start-up procedures.

Cut sheets of products.

Manufacturer's inspection and maintenance instructions for backflow preventer (if applicable).

Manufacturer's maintenance and operation instructions for all irrigation system components.

Warranty:

Submit manufacturer written warranty for irrigation components, two year minimum.

Contractor warranty is for 3 years from Date of Acceptance, G.C.C.1801.4A

-4-

**REVISION OF SECTION 623
LANDSCAPE IRRIGATION**

1.6 CONTRACT RECORD DRAWINGS

Prior to the installation of irrigation system, the Contractor will provide on-site copies of original irrigation design Contract Drawings "Record Contract Drawings". Contractor to revise Record Contract Drawings in red ink as Work progresses to show any changes to the plan and include field dimensions. Record Contract Drawings shall be brought up-to-date prior to any Pay Application Submittals that contain irrigation installation. Should the Contractor choose to utilize GPS for the purposes of documenting Work in progress, a hard copy print will need to be provided prior to Pay Application Submittal. A print of Record Contract Drawings shall be available at Project Site for review by the Project Manager at any time during the project.

Record Contract Drawings shall encompass entire scope of work including any altered existing equipment and altered zones, and notate the Automatic Irrigation Controller zone number, type of irrigation, GPM, operating PSI for any altered or added zone.

Preparation of Contract Record Drawings: Dimension from range points showing the location of the following items:

Point of connection.

Meters and vault dimensions

Curb Stops

Isolation Valves

Drain Valves

Backflows

All Service lines (horizontal and vertical) within the City and County of Denver Right of Way

Routing of irrigation mainline. Provide dimensions for each one-hundred linear feet (100 L.F.) maximum along each routing and for each change of direction.

Routing of non-pressure lateral lines, layout and size.

Valves: Sprinkler control, Quick coupling, Drain valves, Gate, Air Relief, Flush

Hydrometer or Master Valve/ Flow Sensor assemblies

Soil Moisture Sensors

Wire splice boxes

Control wire routing if not with pressure mainline.

Sleeves.

Power service drop or solar panel and battery housing locations.

Other related equipment as directed.

Make dimensions accurately at the same scale used in the original Contract Drawings, or larger. Notes and dimension lettering must be legible.

-5-

**REVISION OF SECTION 623
LANDSCAPE IRRIGATION**

The irrigation legend must be changed to accurately reflect the irrigation equipment installed, if such equipment is not the same as originally specified on the contract documents. This includes flow rates, effective spray diameter/radius and operating pressure of all sprinkler heads.

The Project Manager will not certify any pay request submitted by the Contractor if the Record Drawings are not current. Pay requests may be delayed, at the discretion of the Project Manager, if the Record Drawings are not updated.

Final Submittal: Upon completion of Project, prior to final acceptance, secure digital copy of irrigation design from the Project Manager and record installation information that reflects all changes made over the course of the construction project, prepared by a qualified draftsman. Contract Record Drawings shall include details of any revisions as per actual installation. Deliver and submit to the Project Manager for review the following items:

Digital Contract Record Drawings in both PDF and AutoCAD release compatible with current version used by the City and County of Denver as directed by City Project manager; bound format (include any related X-ref files, plot files and pen settings.) Make any additional changes to the file as directed by the Project Manager prior to final submittal and approval.

Request for final payment will not be certified or processed until all Contract Record Drawing prints and digital files have been received and approved.

1.7 DELIVERY, STORAGE AND HANDLING

- A. **Packing and Shipping:** Deliver all components to job site in original unopened packaging containers prominently displaying manufacturer's name, volume, quantity, contents, instructions, and conformance to local, state, and federal law. Remove and replace cracked, broken, or contaminated items or elements prematurely exposed to moisture, inclement weather, snow, ice, temperature extremes, fire, or jobsite damage.
- B. **Handling, Storage, and Delivery of PVC Pipe:**
 - Exercise care in handling, loading and storage of PVC pipe.
 - Provide forty-eight (48) hours advance notice of delivery to the Project Manager for observation of unloading and handling of PVC materials during delivery.
 - All PVC pipe shall be transported in a vehicle which allows length of pipe to lie flat so as not to subject it to undue bending or concentrated external loads. All sections of pipe that have been dented or damaged shall be discarded, and shall be replaced with new piping.
- C. **Storage and Protection:** Deliver, unload, store, and handle materials, packaging and bundling products in dry, weatherproof condition in manner to prevent damage, breakage, deterioration, intrusion, ignition, and vandalism.
- D. **Only materials and equipment meeting project specifications and to be used as part of Project shall be stored on site. Project Manager may verify at any time during construction period**

-6-
**REVISION OF SECTION 623
LANDSCAPE IRRIGATION**

1.8 JOBSITE CONDITIONS**A. Existing Conditions:**

Soil Conditions: The Contractor is responsible for investigating the type of soil and conditions in which lines are to be installed. No extra payment will be allowed due to difficulty in trenching.

Contractor is responsible for understanding the scope of related operations as specified and indicated in the Contract Drawings and Specifications before beginning Work under this Section.

Report unsatisfactory conditions in writing to the Project Manager within twenty-four (24) hours of discovery.

B. Protection of Property:

- 1) Protect buildings, walks, walls, and other property from damage. Erect and maintain barricades, warning signs and lights, and provide guards as necessary or required to protect all persons on the site. Damage caused to asphalt, concrete, monuments, structures or other building material surfaces shall be repaired or replaced at no cost to the City. Restore disturbed areas to original condition.
- 2) The Contractor is responsible for potholing of all existing utilities, irrigation lines or any other underground improvements that may be damaged due to the installation of Irrigation Systems.

C. Protection of Existing Trees:

- 1) Consult with the Office of the City Forester as requested by the Project Manager prior to trenching or boring within tree drip-lines. No trenching will be allowed within tree root zone, only boring will be allowed.
- 2) Directional boring that is permitted within tree protection area must occur at thirty-six inches (36") below grade and may not take place anywhere within four feet (4') of the critical root zone as defined by City Forester. Any exception must be agreed upon by the Office of the City Forester or the Project Manager.

D. Protection and Repair of Underground Lines:

- 1) Request utility locates seventy-two (72) hours in advance of any excavations by calling the Utility Notification Center of Colorado at 811. Take whatever precautions are necessary, including pot holing to verify location and depth to protect these underground lines from damage. If damage does occur, all damage shall be repaired by the Utility Owner. All costs of such repairs shall be borne by Contractor.
- 2) The Contractor is required to contact all private utility companies including Denver City Departments to locate all private utilities. The request for locates shall be a minimum of seventy two (72) hours prior to proceeding with any excavation. If, after such requests private utilities are encountered and damaged by the Contractor these shall be repaired at no cost to the City. If the Contractor damages staked or located private utilities, they shall be repaired by the Utility Owner at the Contractor's expense.

-7-

**REVISION OF SECTION 623
LANDSCAPE IRRIGATION**

- E. Replacement of Paving and Curbs: Any damage due to work that occurs adjacent to or crosses existing roadways, paths, trails, curbing, sidewalks, etc. shall be restored to original condition at the contractor's expense, and the satisfaction of the Project Manager.

1.9 WARRANTY/GUARANTEE

Per GCC 1801, the contractor shall provide a 3-year warranty from the date of Final Acceptance for material, workmanship and products related to the irrigation systems.

Losses due to vandalism before Final Acceptance shall be the Contractor's responsibility.

Once Final Acceptance is granted, the City will maintain the Green Infrastructure in the Water Quality Planters during warranty period. The Contractor is responsible to monitor and coordinate Automatic Irrigation Controller scheduling and maintenance with the Project Manager, City Owner's Representative, Contractor's Superintendent for planting areas under the Contractor's warranty.

The Contractor shall make warranty repairs and replacements within three days of notification from the City. If the Contractor fails to make repairs within three days, the City will make such repairs at the Contractor's expense. The City Project Manager reserves the right for to make temporary repairs during the warranty period as necessary to keep systems in operating condition without voiding the Contractor's warranty, nor relieving the Contractor of their responsibilities.

1.10 TURN OVER ITEMS

Where applicable, furnish the following maintenance items to the Project Manager and the City Owner's Representative prior to Final Acceptance:

Two (2) sprinkler heads for each size and type specified.

Two (2) nozzles for each type of head.

Two (2) head adjustment tools for each type of head installed.

Two (2) valve keys for operating each type of manual valve. (Manual drain valves, isolation valves).

Two (2) valve keys and hose swivels for each type of quick coupling valve.

Two (2) valve decoders.

1.11 MAINTENANCE DURING PROJECT CONSTRUCTION

Within Limits of Construction: Contractor shall fence, water, and keep weed free any turf, trees and any plantings within the limits of construction. Contractor is responsible for maintenance which includes picking up trash, weed control and mowing of turf and native areas within the limits of construction. Contractor is responsible for watering existing landscape within limits of construction. Turf and plants affected by mainline work or irrigation water service shutdown during irrigation season shall receive watering per Denver Water Guidelines, with no interruption of watering greater than seventy-two (72)-hours. Contractor is responsible for maintenance until final acceptance is granted.

-8-
**REVISION OF SECTION 623
LANDSCAPE IRRIGATION**

Part 2 – PRODUCTS**GENERAL**

Equipment must have performance characteristics to operate per the design conditions indicated. If any discrepancy or conflict exists between the quantities of equipment listed in the schedule and quantities shown on the Contract Drawings, the greater quantity shall govern.

All material shall be of the highest grade possible and where applicable, shall be marked accordingly and shall be new.

PIPE AND PIPE FITTINGS**Copper Pipe and Fittings:**

Pipe: Type K, rigid, hard tempered.

Fittings - Wrought copper, solder joint type. Joints - Soldered with solder, forty five percent (45%) silver, fifteen percent (15%) copper, sixteen percent (16%) zinc, and twenty four percent (24%) cadmium and solidus at 1125° F and liquids at 1145° F.

Main and Lateral Lines:

Main Lines (pressurized, downstream of backflow prevention units):

Class 200 PVC BE, size one inch (1") to two inch (2").

Velocities in PVC mainline shall not exceed five feet (5') per second.

All PVC pipe shall conform to the requirements of Type 1-ASTM-D-2241.

PVC Lateral Lines

Class 200 PVC BE, size one-inch (1") to three-inch (3") inch.

Velocities in PVC mainline shall not exceed five feet (5') per second.

All PVC pipe shall conform to the requirements of Type 1-ASTM-D-2241.

Sleeving:

Horizontal sleeves under paved surfaces: Class 200 PVC.

Vertical sleeves for access to drains and valves: Class 200 PVC.

Horizontal sleeving for boring applications: HDPE.

Brass Pipe and Fittings:

Brass Pipe: Eighty-five percent (85%) red brass, ANSI Schedule 40 screwed pipe.

Fittings: Medium brass, screwed one hundred twenty five (125) pound class.

Mainline larger than three (3") inch to be installed using tapping saddles.

-9-

**REVISION OF SECTION 623
LANDSCAPE IRRIGATION**

Pipe and Fittings:

Identification Markings: Identify all pipe with following indelible markings:

- Manufacturer's name.
- Nominal pipe size.
- Schedule of class.
- Pressure rating.
- NSF (National Sanitation Foundation) seal of approval.
- Date of extrusion.

Class 200 PVC Pipe (pressurized main line two inches (2") and smaller, where allowed by Project Manager):

- Pipe will be assembled with Schedule 80 PVC fittings and solvent welded using ASTM-F-656 purple primer followed with heavy bodied ASTM-D-2564 cement.
- Main lines shall be installed with concrete thrust blocks as per Details.

Class 200 PVC Pipe (all lateral lines)

- Pipe will be assembled with Schedule 40 PVC fittings and solvent welded using ASTM-F-656 purple primer followed with heavy bodied ASTM-D-2564 cement.

Risers for Pop-up Heads: Shall be swing pipe, 0.49 ID, operating pressure of eighty (80) PSI.

VALVES

Gate Valve or Isolation Valve:

- Valve for one and one-half inch (1-1/2") and smaller mainline (solvent-weld): Shall be cast iron body, threaded ends, left-hand opening, square nut operated, rubber resilient seated, FIPT joint AWWA gate valve with clear waterway equal to full diameter of pipe. Able to withstand continuous working pressure of one hundred fifty (150) PSI. Wheel type handle is unacceptable.

Automatic Control Valve:

- Automatic Valve for Potable Water System: Rain Bird PEB Series Valve having manual flow adjustment and both internal and external manual bleed. PRS-D shall be used if pressure at the heads is greater than ten pounds over the optimal pressure as stated on the contract drawings or measured in the field.

Systems with AC Power shall utilize decoders BL-5201, and BL-5201MV as master valve decoder.

Valve Riser: Epoxy coated ductile iron riser with integral stainless-steel angle valve or approved equal.

Install one flexible marker tag on each valve. Mark each tag with inedible ink indicating zone number. Tags shall be: Potable water systems (yellow), Non-potable systems (purple).

Manual Drain Valve:

- Drain Valve: Mueller Oriseal #H-10283 or AY McDonald, one inch (1") 3061 with brass swing joint assembly, or approved equal.

-10-
REVISION OF SECTION 623
LANDSCAPE IRRIGATION

Quick Coupling Valves:

Buckner QB44RCAR10 brass two-piece body with winged stabilizer, designed for working pressure of one hundred fifty (150) PSI; one inch (1") FIP size, or approved equal, as shown on drawing.

Quick Coupling Valves immediately after the backflow shall be used for winterization and shall be constructed of all brass swing joint and fittings. All other Quick Coupling Valve swing joints shall be constructed as shown on the details.

Hydrometers, Master Valves and Flow Sensors:

Baseline BHM Hydrometer, normally open, Two-Wire Ready, per plan.

Valve Boxes:

All valve boxes will have a stainless steel hex bolt locking system.

Isolation Valves, Quick Coupling Valves, Drain Valves, Wire Splices and Ground Rods: Carson Brooks, Model #910-4, ten inch (10") round box or approved equal.

Electric Control Valve Box: Shall have locking cover branded with the zone numbers.

Three-quarter inch (3/4") through one-inch (1") valves: Carson, Model #1419 standard box with bolt down T-cover or approved equal.

One and one-half inch (1-1/2") and two-inch (2") valves: Carson 1220 jumbo valve box with bolt down T-cover or approved equal.

Box color for valves:

Green for potable systems.

Gravel Leveling Bed and Drainage Sump in Valve Boxes: three quarters inch (3/4") crushed gravel covered in geo-textile fabric, as indicated on Contract Drawings.

Backflow Preventer:

High hazard, reduced pressure type, approved by University of Southern California (USC) or other approved testing laboratory; fully ported, ball-type gate valves on units 2-inch or smaller, as manufactured by Febco Model 825YA or approved equal. Resilient gate valves on units larger than two inch (2"); as manufactured by Febco Model 880V or approved equal.

Backflow Preventer Cover: StrongBox stainless steel enclosure (or approved equal) of appropriate size.

Concrete Pad: per direction of the project manager following CDOT Specifications.

Air Relief Valve: On mainlines three inches (3") or larger, as per contract drawings: Bermad 4415 (all cast iron) 2-inch double purpose vacuum air release valve or approved equal.

Pressure Reducing Valve: Watts 223-HP where system pressures exceed one-hundred (100) PSI, or approved equal.

-11-
REVISION OF SECTION 623
LANDSCAPE IRRIGATION

SPRINKLER HEADS

Heads: Provide fabricated riser units of the type and size as indicated on the Contract Drawings. Heads of a specific type or function in the system shall be of the same manufacturer and shall be marked with the manufacturer's name and identification in such a position that they can be identified without being removed from the system.

Pop-Up Sprinkler Heads: Rain Bird RD12-S-P-30, or approved equal.

Pop-Up Sprinkler Nozzles shall be Rain Bird MPR Series nozzle, or approved equal. Strip series, rotary, and VAN nozzles may be used for specific approved applications at the direction of the Project Manager.

Flexible Connectors to Lateral Pipe:

Pop-up Heads: Shall be one-half inch (1/2") swing pipe

Gear Driven Heads: Shall be manufactured PVC swing joints as per detail.

AUTOMATIC CONTROL SYSTEM

See Water Quality Planters Specification 32-84.33 Section "Automatic Irrigation Controllers".

Two-Wire Specifications:

The two-wire shall have the following operating voltage: 600 V RMS max.

The two-wire shall have the following temperature rating: 140°F (60°C)

The two-wire shall meet one criterion within each of the following categories:

Outer Jacket

High density polyethylene (HDPE) between 0.035" and 0.048" thick, conforming to ICEA S-61-402 and NEMA WC5

Conductors - two of the same gauge, conforming to ASTM B-33, B-3, or B-8

Bare Copper

Tin coated solid copper

Conductor Arrangement

Conductors that are twisted

Conductors that are laid in parallel

Conductor Insulation

Low density, high molecular weight polyethylene (PE) with a thickness of 0.045"

PVC conforming to UL-493 or UL-719 for thermoplastic-insulated style UF (Underground Feeder)

Conductor Color Coding

Black & red (recommended)

Black & white

Blue & red

-12-
REVISION OF SECTION 623
LANDSCAPE IRRIGATION

Miscellaneous control wiring materials:

Materials for standard wire systems.

Control Wire connections and splices shall be made with 3M DBR/Y-6M direct bury splice, or approved equal, UL listed dry splice methods.

Mainline Tracer Wire: One (1) continuous AWG UL #12 tracer wire as detailed above all mainline

Splice Box: Carson ten-inch (10") round box or approved equal.

MISCELLANEOUS MATERIALS

Soil Moisture sensors: Baseline biosensor BL-5315B. Soil moisture sensors shall be installed in the quantity shown on plans, and the approximate locations shown, and shall be installed per manufacturer's recommendations.

Part 3 – EXECUTION

PREPARATION

Utility Locates: Contact Utility Notification Center of Colorado at or 8-1-1 or 1-800-922-1987 prior to any excavation, for the marking of underground member utilities. The indication of utilities on the Contract Drawings does not relieve the Contractor of the responsibility for utility location. Contractor is responsible for potholing all utility locations to verify the depth and locations. Potholing related to irrigation installation shall be considered incidental to irrigation installation and will not be paid for separately. Route trenches to avoid existing utilities. Verify with the Project Manager any required relocation prior to installation.

Landscape Plan Review and Coordination: Contractor will be held responsible for coordination between landscape and irrigation system installation. Landscape material locations shown on the Landscape Plan shall take precedence over the irrigation system equipment locations. If irrigation equipment is installed in conflict with the landscape material locations shown on the landscape plan, the Contractor will be required to relocate the irrigation equipment, as necessary, at Contractor's expense.

Pressure Verification: Contractor shall field verify the tap size, static pressure and verify Gallons Per Minute flow at the project site, prior to commencing Work or ordering irrigation materials, and submit findings in writing to the Project Manager. If Contractor fails to verify tap size, static water pressure and flow prior to commencing Work or ordering irrigation materials, Contractor shall assume responsibility for all costs required to make system operational and the costs required to replace any damaged landscape material. Damage shall include all required material costs, design costs, labor costs and plant replacement costs.

Inspection: Examine areas and conditions under which Work of this Section is to be performed. Do not proceed with Work until unsatisfactory conditions have been corrected.

Grading operations, with the exception of fine grading, shall be completed and approved by Project Manager before staking or installation of any irrigation system begins.

Layout: Layout and stake system before beginning installation. Staking shall occur as follows:

Mark, with paint, routing of pressure supply line and flag heads for all new zones. Contact the Project Manager forty-eight (48) hours in advance and request review of staking. The Project Manager will review staking and direct changes if required. Review does not relieve installer from coverage problems due to improper placement of heads after staking.

-13-
REVISION OF SECTION 623
LANDSCAPE IRRIGATION

Review backflow prevention device location and operation with the Project Manager prior to mainline installation.

EXCAVATION AND BACKFILL

Install mainline and service line pipe and wire sleeving under existing asphalt paving, concrete walks and critical root zones by directional boring. Pot-hole existing utilities for location and depth in advance of boring operations. When pot-holing in cross streets: include all permits, traffic control, backfill, compaction and surface restoration as required by the City and County of Denver Transportation Engineering Standards and Specifications. Compact backfill at bore pits around the end of sleeves to ninety-five percent (95%) compaction in landscape areas.

Excavation:

Trenching:

Trench excavation shall follow, as much as possible, the layout shown on Drawing. Dig trenches straight and support pipe continuously on bottom of trench. Trench bottom shall be clean and smooth with all rock and organic debris removed. Comply with OSHA standards for all trenching and excavation.

Trenching under limb spread of existing trees: only boring will be allowed within tree drip line.

Clearances and Depths:

Main pressure line: Make trenches of sufficient width to properly assemble and position pipe in trench. Clearances:

Mainline and Lateral Piping clearance: Minimum clearance shall be one inch (1") horizontally on both sides of the pipe.

Line Clearance: Provide minimum six inches (6") of clearance between each line, and minimum twelve inches (12") of clearance between lines of other trades.

Installation of multiple runs of piping in common trench is prohibited.

Pipe and Wire Depth to finish grade:

Pressure Supply Piping: Twenty-seven inches (27") from the top of pipe, maximum variation +/- one inch (1").

PVC Sleeving: At specified pipe or wire depth.

Non-pressure Piping (gear driven heads): Eighteen inches (18") from top of pipe, maximum variation two inches (2").

Non-pressure Piping (pop-up heads):

Turf and planter zones: eighteen inches (18") from top of pipe.

Control Wiring: Side of pressure main when installed in the same trench; twenty-four (24) inches deep when installed separately from the mainline trench.

Vibratory Plow: Not permitted without written authorization of the Project Manager.

-14-
REVISION OF SECTION 623
LANDSCAPE IRRIGATION

INSTALLATION OF IRRIGATION EQUIPMENT

Locate all equipment as near as possible to locations designated. Deviations shall be reviewed and approved by the Project Manager prior to installation.

Service Line Piping (copper or ductile iron piping from water meter to connection to backflow prevention device) - When pipe installation is not in progress, or at the end of each day, close pipe ends with tight plug or cap.

Copper piping – Installation shall match specifications for copper service line as required by Denver Water and in accordance with City and County of Denver Building Codes.

Sleeving:

Install sleeving under any hard surface prior to surface being installed to accommodate piping and wiring.

Minimum depth to top of pipe shall be determined by depth of mainline and lateral lines.

Provide for a minimum cover of twenty-four (24) inches between the top of the sleeve and the bottom of the aggregate base for all pressure and non-pressure piping installed under asphaltic concrete or concrete paving.

Sleeving located under areas where asphalt or concrete paving will be installed shall be bedded with a sand layer six inches (6”) below the pipe and six inches (6”) above the pipe.

Sleeving under existing walks or concrete pavement shall be done by boring or hydraulic driving. Where cutting of asphalt and/or concrete is necessary, it shall be done per the City and County of Denver Right of Way Standards. Cutting of concrete is not permitted the contractor shall remove the entire concrete section or “stone”.

Compact backfill material in three uniform lifts at ninety-five percent (95%) determined in accordance with ASTM D698 using mechanical tamping devices under pavement.

Do not allow sleeves to become filled with soil or other undesirable material. Tape ends of sleeves until commencement of pipe installation.

Mark sleeves on hard surfaces with a three inch (3”) by three inch (3”) “X” as per contract drawings in a manner to ensure easy location in the future.

Sleeve size requirements for wire and pipe, control wire shall be placed in sleeving separate from pipe sleeving:

| | |
|-------------------------|--------|
| 1” to 1-1/4” Pipe: | 2” PVC |
| 1-1/2” to 2” Pipe: | 4” PVC |
| 1 to 25 Control Wires: | 2” PVC |
| 26 to 50 Control Wires: | 3” PVC |

All connection fittings between PVC or any other pipe material being used are to be made a minimum of twenty-four inches (24”) away from any hard surface or tree drip line.

Fittings to be used as couplings between PVC shall be an epoxy coated repair coupler with joint restraints and stainless-steel pipe stiffener, installed as specified per the Contract Drawings and Manufacturer’s recommendations.

-15-
REVISION OF SECTION 623
LANDSCAPE IRRIGATION

Installation of Piping:

Solvent Weld PVC Pipe (where approved by Project Manager): Lay pipe and make all plastic to plastic joints in accordance with manufacturer's recommendations. Do not install pipe when air temperature is below forty degrees (40°) F.

Control Wiring:**Two Wire Systems:**

Two-wire path may be looped, spliced, or branched.

The distance from the controller to the end of any one wire run shall not exceed the maximum distance specified for the gauge of wire.

The distance from the controllers to the farthest device shall not exceed a distance of 5000 feet (1524 m) using 14-gauge wire or 8000 feet (2438.4 m) using 12-gauge wire.

The total length of wire connected to any one controller shall not exceed 16,000 feet (4572 m) on 14-gauge or 12-gauge.

The lengths of wire for DC powered systems shall reduce by half from distances above.

Bury control wiring between Automatic Irrigation Controller and electric valves in pressure supply line trenches, strung as close as possible to mainlines with such wires to be consistently located to one side of pipe, or in separate trenches.

Provide an expansion loop at every mainline change of direction, every electric control valve location (in valve box), and every five hundred feet (500').

Form expansion loop in each control valve box by wrapping twenty-four inches (24") of wire around a one-inch (1") pipe and withdrawing pipe.

Install all control wire splices not occurring at control valve in a separate Carson Industries Model #910-10 body with 910-4 bolt down T-cover wire splice valve box or approved equal.

Wire Testing:

Existing wiring indicated to remain on documents is to be ohm-tested for continuity prior to construction. Contractor to produce report and copy the Project Manager of the results of such testing.

New wiring: All new wiring to be tested for proper resistance prior to connection to valves and controller(s) for continuity. The Contractor is to produce the report and copy the Project Manager of the results of such testing.

Two-wire shall be tested before decoders are installed.

Installation of Valves:

Electric Control Valves: Install electric control valves as detailed on the Contract Drawings.

Valve decoders shall be connected to the valve and two wire path and shall be mounted to the side of the valve box with the serial number face up.

Quick Coupling Valves: Install quick coupling valves as detailed on the Contract Drawings.

Drain Valves: Install manual drain valves at all low points in pressure supply line, whether indicated on the Contract Drawings or necessitated by actual conditions, to ensure proper drainage of the mainline.

-16-
REVISION OF SECTION 623
LANDSCAPE IRRIGATION

Isolation/Gate Valves: Install as detailed in locations shown on the Contract Drawings.

Valve Boxes: Install one valve box for each type of valve as detailed. Install compacted gravel leveling bed after compaction of subgrade and prior to setting of valve box.

Valve Box Identification Branding:

| | |
|----------------------|------|
| Isolation/Gate Valve | “GV” |
| Quick Coupler Valve | “QC” |
| Manual Drain Valve | “DV” |
| Wire Splice Box | “SB” |
| Grounding Rod | “GR” |

BACKFLOW PREVENTION DEVICES

Backflow Prevention Device: Contractor must meet all applicable laws, rules and codes, including but not limited to Uniform Building codes and applicable amendments Plumbing Codes and State Water Regulations. Assemblies must be installed per the manufacturer’s specifications. Backflow devices shall not be installed within a sight triangle.

Install in strict accordance with current requirements of Denver Water. Connections to the Denver Water System are to have an approved assembly for the type of protection they provide, either isolation or containment.

Successful Testing of backflow assembly by a certified Backflow Prevention Assembly Tester is Contractor’s responsibility and any cost shall be considered incidental. Test reports shall be forwarded to Denver Water in accordance with the State of Colorado regulations. Copies of the report, the tester’s certification and the certification of the testing equipment used are to be forwarded to the Project Manager.

INSTALLATION OF SPRINKLER HEADS

Install sprinkler heads where designated after the Project Manager has approved staking. Set to finish grade as detailed.

Spacing of heads shall not exceed the maximum indicated on the Contract Drawings unless re-staked or as directed by the Project Manager. In no case shall the spacing exceed maximum recommended by manufacturer.

Install gear driven heads on swing-joint risers as detailed. Swing joints to non-pressure lines shall be set at no more than forty-five degrees (45°) or less than ten degrees (10°).

Install pop-up heads on swing pipe as detailed.

Adjust part circle heads for proper coverage. Adjust heads to correct height after planting is installed. Plant placement shall not interfere with intended sprinkler head coverage, piping, or other equipment. The Project Manager may request nozzle changes or adjustments without additional cost to the City.

-17-
**REVISION OF SECTION 623
LANDSCAPE IRRIGATION**

BACKFILLING

Do not begin backfilling operations until all piping and system components have been inspected by or by the Project Manager. Backfilling shall not be done in freezing weather unless authorized by the Project Manager.

Leave trenches slightly mounded to allow for settlement after backfilling is completed.

Trenches shall be finish graded prior to walk-through of system by the Project Manager.

Contractor shall be responsible for providing suitable backfill if excavated to meet backfill, compaction, and final grade requirements.

Do not leave trenches open. Open excavations shall be protected in accordance with City and County of Denver Right of Way Standards and OSHA regulations.

Utilize flood compaction of planters to meet compaction requirements of soils.

SOIL MOISTURE SENSOR

Moisture Sensor: Install in accordance with manufacturer's instructions, and as shown on the Contract Drawings.

Install sensor(s) prior to starting any irrigation schedules for new planting area programs.

ADJUSTING

Upon completion of installation, the contractor shall "fine-tune" entire system by regulating valves, adjusting arcs and radius, and setting pressure reducing valves at proper and similar pressure to provide optimum and efficient coverage. Flush and adjust all sprinkler heads for optimum performance and to prevent overspray onto walks, roadways, and buildings as much as possible. Heads of same type shall be operating at same pressure within plus or minus ten percent (10%).

If it is determined by the Project Manager that irrigation adjustments will provide improved coverage and water distribution, the Contractor shall make such adjustments prior to Final Acceptance.

Adjustments may include but are not limited to changes in nozzle sizes, degrees of arc, and control valve flow control regulations. Adjustments shall be completed at no additional costs to the City.

All sprinkler heads shall be set perpendicular to finish grade or within allowable limits shown on Contract Drawings.

Areas that do not conform to designated operation requirements, due to unauthorized changes or poor installation practices, shall be immediately corrected at no additional cost to the City.

FIELD QUALITY CONTROL

Flushing: After piping, risers, and valves are in place and connected, but prior to installation of sprinkler heads, quick coupler assemblies, and hose valves, thoroughly flush piping system under full head of water pressure from dead end fittings. Maintain flushing for five (5) minutes through furthest valves. Cap risers after flushing.

Testing Pressurized Mainline: Prior to installing any plant materials, arrange and conduct pressure test(s) in the presence of the Project Manager, Contractor's Superintendent, and Installer. Arrange for testing a minimum of forty-eight (48) hours in advance. The contractor is responsible to supply the hydrostatic test pump and all other equipment required to complete the test.

Set in place, cap and pressure test all piping under paving, in presence of the Project Manager prior to backfilling and paving operations.

-18-
REVISION OF SECTION 623
LANDSCAPE IRRIGATION

After backfilling and installation of all control valves, fill pressure supply line with water, and pressurize to forty (40) PSI over the designated static pressure or one hundred twenty (120) PSI, whichever is greater, for a test period of two (2) hours.

All isolation valves, angle valves, ball valves and zone valve flow controls are to remain open during testing.

Leakage, Pressure Loss:

Fused HDPE or Solvent welded PVC Pipe: Test is acceptable if zero pounds of pressure is evident during the test period.

Leaks: Detect and repair leaks. Replace defective pipe with new full length pipe section. No pipe splices will be accepted within pipe sleeve. No PVC pressure couplings or slip-fix repair couplings will be allowed.

Retest system until test pressure can be maintained for duration of test.

COMPLETION INSPECTION

Arrange for the Project Manager to be present. Provide a minimum of forty-eight (48) hours of notice in advance of walk-through.

Entire system shall be completely installed and operational and trenches shall be finish graded and sod and seed in place prior to scheduling of walk-through.

Electrically operate each zone in its entirety for the Project Manager the time of walk-through.

A project inspection walk through shall include but is not limited to the following:

Contractor shall adjust, straighten and nozzle all heads prior to walk through. Review operation, coverage, head/nozzle adjustment, and system adjustment per specifications.

Contractor shall have all valves boxes unlocked prior to walk through. Open valve boxes to confirm materials, filter fabric, gravel bedding, wire splices, compaction, elevation, workspace access within boxes, clearance from lid and bedding, locking mechanisms, and zone branding. Interior of boxes should be free of foreign material, only filter fabric shall be visible in the bottom of boxes. All valves must be tagged with zone identification, Christy's valve marker tags or approved equal and valve box lids must be branded with zone valve identification. Verify connections in all valve and wire splice boxes.

Contractor shall provide documentation that resistance tests for all spare common and hot wires or two-wire paths has been performed and the results for ohms reading on each wire tested.

Confirm irrigation heads are at specified elevation and distance(s) from paved surfaces and curbs, plumb and soil compacted.

Inspect concrete size and elevation of pads for backflow assembly, hydrometer, and enclosure pads. Confirm quality of concrete, finishes, access to the Irrigation Controller and spare conduit/sleeving as required for wiring.

Review trench and related excavation repair including backfill, compaction, fine grade, and planting installation.

Review appropriate use of purple valve lids and other product as required for reuse water applications.

Generate a punch list of items to be corrected prior to Final Completion.

-19-
REVISION OF SECTION 623
LANDSCAPE IRRIGATION

Furnish all materials and perform all work required to correct all inadequacies of coverage due to deviations from Contract Documents.

CLEANING

Maintain continuous cleaning operation throughout duration of Work. Dispose of, all trash, waste materials, debris and excess soil generated by installation of irrigation system, off-site, at no additional cost to the City. Contractor shall clear all debris, including, soil, from all paths, walks, roads, and other hard surface areas.

PROTECTION

Restrict vehicular and pedestrian traffic from areas where irrigation has been installed. Erect temporary fencing or barricades and install warning signs as required by the Revocable Right of Way permit.

END OF SECTION

**REVISION OF SECTION 626
PUBLIC INFORMATION MANAGEMENT**

Section 626 of the Standard Specifications is hereby revised for this project as follows:

Subsection 626.01 shall include the following:

DESCRIPTION

This work consists of providing Public Information Management throughout the duration of the project. The Contractor shall submit the Public Information Management deliverables to the Engineer for approval.

Anticipated communication issues on this project include:

- (1) Lane closures on Larimer Street and Speer Boulevard♦
- (2) Closure of the Cherry Creek Trail
- (3) Closure of Larimer Street bridge over Cherry Creek
- (4) General updates on construction schedule

CONSTRUCTION REQUIREMENTS

- (a) *Public Information Manager (PIM)*. The Contractor shall designate a PIM who shall be responsible for all activities associated with Public Information Management for this project. Within ten days following the date of the Notice to Proceed, the Contractor shall submit the name, contact information, and resume qualifications of the PIM and the Backup PIM for approval by the Engineer. The RCM will also review the PIM's and Backup PIM's resume. The PIM shall be identified, approved, and able to perform all requirements in this Section at least 14 days before the start of work. If this is not feasible, the Contractor is responsible for the project start-up deliverables and the individual preparing the deliverables shall meet the minimum qualifications of the PIM. The PIM shall have a minimum of five years of professional experience in public/media relations, marketing, or other related field and good verbal and written communication skills. Administrative/business office experience is not considered experience in a related field. The PIM shall not be the Project Superintendent.
- (b) *Activities of the PIM*. From the Notice to Proceed through the * Final Acceptance of the project, the PIM shall be responsible for the following:
- (1) *Project Onboarding Checklist*. The PIM or Backup PIM shall complete and update the Project Onboarding Checklist (<https://form.jotform.com/71167524405150>) on a monthly basis or as requested by the Engineer. The checklist will assist the PIM and DOTI with tracking required activities and deliverables.
 - (2) *On-Call*. The PIM shall be available or on-call each day there is work on the project and shall be available upon the Engineer's request outside of normal working hours.
 - (3) *Weekly Project Meetings*. The PIM shall participate in weekly project meetings held on-site. At the meetings, PIM shall discuss weekly communications issues and shall develop strategies to provide timely details for upcoming media advisories/press releases, lane closure reports, website updates and information line recordings.

Public Information Office. The Contractor shall establish a public information office equipped with a telephone, a local telephone number with voicemail, a computer, and an email address. The public information office may be located within the project office, off-site, or within the PIM's office. The telephone line will be the Project Hotline and shall be included on the Project Information signs. The voicemail greeting shall be updated at least weekly. The greeting shall include the project's completion date, forthcoming activities for the update period, and allow the caller to leave a voice message.

-2-

**REVISION OF SECTION 626
PUBLIC INFORMATION MANAGEMENT**

The PIM shall answer calls, check voicemail and email messages, and respond to messages throughout each day that construction operations are in effect. The PIM, and when necessary the Engineer, shall respond to all inquiries with a phone call, a voice message, or an email within one work day. The PIM shall document the name, contact information, either a phone number or email address, and the action taken. Within two days of receiving the message, the PIM or Backup PIM shall enter message details and follow-up action into Dialog.

(4) *Lane Closure Reporting.*

(i) *Weekly Lane Closures.* The PIM shall provide the planned weekly lane closures and updates to the Engineer by Thursday at 12:00 P.M. for the upcoming Sunday through Saturday. The information will be provided in a media report. The PIM shall develop Traffic Advisories that include lane closure and update information. The PIM or Backup PIM shall notify the Engineer one week in advance of all planned “no work” periods. The Engineer will approve the Lane Closure and Updates by each Friday at 3:00 P.M.. Each Monday by 12:00 P.M., the PIM shall verify that the lane closure and update information is accurate. If corrections are necessary, the PIM shall coordinate those corrections with the Engineer.

(ii) *Real-Time Lane Closure Changes.* The PIM or Backup PIM shall notify the Engineer at least 24 hours in advance for changes to an approved Lane Closure.

(5) *Public Information Collateral.* ## The PIM shall develop a variety of Public Information Collateral to share project information with the public as necessary for major project milestones such as long-term closures or impactful construction activities. Collateral includes the following:

(i) *Photographs and Video Recordings.* The PIM shall take photographs and video recordings on regular intervals and submit them to the Engineer. A cell phone camera is permitted. Photographs and video recordings may capture traffic control, paving, slope repair, erosion control, bridge deck, and rail work activities. Photographs and video recordings may also include other key areas of work as identified by the Contractor or the Engineer and will be used in Public Information Collateral. The Contractor shall submit a minimum of two digital photographs or video recordings each month to the Engineer. Each photograph and video recording shall include project number, project code, date, time, location and station or milepost, and name of person taking the picture or video recording.

(ii) *Web Page Updates.* The PIM shall work with DOTI to develop the latest project information for the internet web page content. The PIM shall supply information for the web page in a DOTI approved format. When applicable, the updates shall contain all appropriate web page links to and from other sites. The PIM shall provide updated information at least weekly. DOTI will update the web page.

Project Fliers. The Contractor or PIM shall develop Project Fliers using the DOTI template and shall include DOTI’s logo, and at the Engineer’s discretion may include the project logo. The Contractor or PIM shall contact the Engineer for copies of the templates. At least 14 days prior to delivering Project Fliers, the Contractor or PIM shall prepare and submit a draft of the flier to the Engineer. The Engineer’s review will not exceed seven days. Fliers shall be approved by the Engineer before distribution. Fliers shall be delivered in person, by mail, and by email.

-3-

**REVISION OF SECTION 626
PUBLIC INFORMATION MANAGEMENT**

The list of recipients shall be developed via <http://uspseverydoordirectmail.com>, the use of a mailing list from county GIS mapping, or other approved method. An email containing the flier shall be sent to stakeholders identified in the Stakeholder List. DOTI will post the Project Fliers on social media.

This project requires Project Fliers at the following milestones:

1. Initial Project Flier
2. Significant lane closure and opening milestones

Initial Project Flier. At least four days prior to the start of work, the PIM shall deliver one approved flier per property and tenant owner within 2 blocks of the project limits. The Initial Project Flier shall provide the project start and end dates, project location, description of work, traffic impacts, scheduled work hours and work days, the Project Hotline, email address, web address, project map, photo of project area, and a construction safety message as defined by CDOT. The estimated number of printed fliers is 100.

Media Relations. The PIM shall develop media releases. The releases shall include detour maps or other visual aids. The PIM shall develop media releases based on major construction milestones such as project start, lane shifts, a traffic switch, closures, and on other occasions as directed by DOTI. At least 14 days prior to the construction milestone, the PIM shall submit a draft to the Engineer for approval. The Engineer's review will not exceed seven days. The media release shall be approved by the Engineer before distribution. DOTI will distribute media releases.

At least 14 days prior to the start of work, the Contractor or PIM shall submit for approval by the Engineer a media release summarizing the project scope, construction phasing, potential construction activities that impact traffic, the project end date, and a summary of project benefits.

DOTI will address all media inquiries and media requests. The PIM or Backup PIM shall immediately notify the Engineer of any on-site situations involving the media. When the media contacts the PIM or Contractor staff, the PIM shall provide the Engineer's contact information.

Maps and Graphics. The PIM shall develop maps, detour maps, and graphics for use in Public Information Collateral.

- (6) *Public Information Plan.* The PIM shall submit a Public Information Plan (PIP) within ten days of the Pre-construction Conference for approval by the Engineer. The PIP shall be specific to the project. The Plan shall include the public information strategies for community and business relations, government affairs and media relations, the stakeholder list, identification of public information issues, proposed outreach, and approach to crisis communications using the Public Information Collateral. The PIP shall be updated as necessary and as directed by the Engineer.
- (7) *Project Meetings.* The PIM shall participate in the weekly project meetings. The PIM shall discuss communication issues, and provide a status on the items in this specification.

-4-

**REVISION OF SECTION 626
PUBLIC INFORMATION MANAGEMENT**

- (8) *Language Assistance for LEP Persons.* DOTI is required to provide access to Limited English Proficient (LEP) persons. LEP persons are individuals for whom English is not their primary language and who have a limited ability to read, write, speak, or understand English. Examples of language assistance include translation of meeting notices and interpretation services at meetings. The PIM shall work with DOTI to provide interpretation services upon request by an LEP person. When the project is located in a community that has greater than five percent LEP persons, Public Information Collateral shall be translated for those individuals. The PIM shall document all measures taken to communicate with LEP persons and record all requests for language assistance.
- (c) *Response Protocol to DOTI and the Public.* The PIM shall follow Table 626-1 in responding to correspondence from stakeholders and the public.

**Table 626-1
RESPONSE PROTOCOL**

| TYPE OF COMMUNICATION | TIMING OF RESPONSE |
|--|---|
| Project Hotline calls and voice messages | Answer calls and check messages throughout each work day. Respond the same day or within 24 hours. Enter details into Dialog within two days. |
| Email messages | Respond the same day. For high volume situations, respond within two work days. Enter details into Dialog within two days. |
| Calls from DOTI Staff | Respond as soon as possible, and within 24 hours. |
| Web page Inquiries | Respond the same day. For high volume situations, respond within two work days. |
| Public Meeting Inquiries | Respond within one week of the meeting. |

- (d) *Deliverable Protocol.* The PIM shall conform to the Project Onboarding Checklist.
- (e) *Public Information Management Contact Sheet.* The PIM shall complete and update a Public Information Management (PIM) Contact Sheet with the names and contact information of the individuals pertinent to Public Information for approval by the Engineer. At a minimum the Contact Sheet will include the Project Engineer, DOTI Website Administrator, and Traffic Control Supervisor. The PIP shall include the PIM Contact Sheet.
- (f) *Stakeholder List.* The PIM shall submit a Stakeholder List as part of the PIP. The Stakeholder List shall include stakeholder's information including stakeholder group, contact name, telephone number, email, and notes on communication needs for the project and project impacts.

METHOD OF MEASUREMENT

Public Information Management will be measured as the number of days elapsed from the project Notice to Proceed date up to the Final Acceptance date.

Failure to provide acceptable Public Information Management will result in withholding of payment for the days affected.

-5-

**REVISION OF SECTION 626
PUBLIC INFORMATION MANAGEMENT**

BASIS OF PAYMENT

Payment will be made under:

| Pay Item | Pay Unit |
|-----------------|-----------------|
|-----------------|-----------------|

| | |
|---|-----|
| Public Information Management (Tier II) | Day |
|---|-----|

Payment for Public Information Management will be full compensation for all work, materials and equipment to provide public information throughout the project in accordance with this specification.

If the Contractor fails to complete construction within the approved contract time, payment will not be made for Public Information Management for the period of time after expiration of the approved contract time. These items shall be provided at the Contractor's expense.

END OF SECTION

Contract Control No. 2021-PROJMSTR-0000693

May 24, 2022

**REVISION OF SECTION 630
UNIFORMED TRAFFIC CONTROL**

Section 630 of the Standard Specifications is hereby revised for this project as follows:

Subsection 630.09 shall include the following:

Uniformed Officers - The Contractor shall employ off-duty police officers to provide traffic control and traffic enforcement throughout the project as required by the Project Manager. Authorization must be made by the Project Manager in advance of working arrangements for Uniformed traffic Control. Arrangements for officers shall be made at least 2 weeks in advance by contacting the following police agency:

Denver Police Department (Special Events Unit)

Phone Number: (720) 913-6034

Subsection 630.18 shall include the following:

Uniformed traffic control will not be measured and paid for separately but shall be included in the item Traffic Control.

END OF SECTION

**REVISION OF SECTION 630
CONSTRUCTION ZONE TRAFFIC CONTROL**

Section 630 of the Standard Specifications is hereby revised as follows:

Subsection 630.06 Channelizing Device (fixed) shall include the following:

Non-metallic drums or tubular markers may be substituted for vertical panel channelizing devices.

Subsection 630.09 General shall include the following:

The flagger's STOP/SLOW sign paddle shall be 18 inches with letters six inches high.

Subsection 630.10(a), shall include the following:

When a different MHT is required for a subsequent construction phase, the request must be submitted to the Program-wide Traffic Control Contractor at least four weeks prior to starting that phase. All proposed methods of handling traffic shall be approved, in writing, by the Project Manager following approval of the Traffic Engineering Services Department.

Approval of the proposed MHT does not relieve the Contractor of liability specifically assigned to him under the contract. The Contractor shall protect warning lights, signs, barricades, and sufficient safeguards around all excavations, embankments, and obstructions.

The contractor shall notify the Project Manager by Thursday at 3:00 P.M. which streets they intend to work on the following week. This notification will be made for all phases of construction.

Subsection 630.10(a) (1) shall be added as follows:

The key elements of the Contractor's method of handling traffic (MHT) are outlined in subsection 630.10(a).

The components of the Traffic Control Plan (TCP) for this project are included in the following:

- Title 8 of the City & County of Denver's General Conditions and Section 630 of the Standard Specifications.
- Latest revised Standard Plan S-630-1, Traffic Controls for Highway Construction and Standard Plan S-630-2.

Special Traffic Control Plan requirements for this project are as follows:

1. During the construction of this project, traffic shall use the present traveled roadway unless identified on the plans or approved by the Project Manager.
2. The Contractor shall be allowed to close Larimer Street between 14th Avenue and Southbound Speer Boulevard as shown on the phasing and detour plans. All other road closures are subject to CCD permitting and as outlined herein.

-2-

**REVISION OF SECTION 630
CONSTRUCTION ZONE TRAFFIC CONTROL**

3. The Contractor shall maintain two lanes of traffic in each direction on Speer Boulevard at all times and three lanes during peak hours unless otherwise approved by the Project Manager.
4. Access to the parking lot on the north side of Larimer Street east of 14th Street shall be maintained. Contractor will need to complete signal modifications for the 14th intersection and provide one lane in each direction during closure of Larimer Street.
5. Contractor shall be allowed two full weekend closures of the northbound Speer intersection provided that the closures do not coincide with any special events in the area.
6. Contractor shall coordinate with Denver Parks Department to allow maintenance access to Creekfront Park from Larimer Street during construction.
7. Work that interferes with traffic shall adhere to the following:
 - The Contractor shall perform all the work between the hours of 8:30 AM and 3:30 PM or as approved by the Project Manager. Weekend and nighttime work will be allowed with the prior written approval of the Project Manager. During this time, only one lane can be closed on each approach.
 - Work will not be permitted that directly or indirectly interferes with the flow of traffic between the hours of 5:30 AM and 8:30 AM Monday through Friday; between the hours of 3:30 PM to 6:30 PM Monday through Thursday; and after 2:00 PM on Fridays unless otherwise authorized by the Project Manager.
 - No work on Holidays
 - Contractor shall not close lanes during special events. A list of special events will be provided by the Project Manager. The Contractor shall coordinate all of the work during any special event with the City and County of Denver.
8. Contractor shall coordinate lane closures with adjacent projects. Contractor shall contact the Project Manager for information on adjacent projects at the time of construction. Contractor shall be aware that adjacent construction projects may be ongoing simultaneously with this project and may require coordination for the placement of traffic control devices, work areas and the timing of any lane or road closures:
9. Access to businesses shall be maintained at all times. Impacts of reconstruction of all driveways shall be coordinated with each property owner prior to performing any demolition.
10. Contractor shall provide traffic control for the installation of utilities within the project limits.
11. The Contractor shall install construction traffic control devices where they do not block or impede other existing traffic control devices or sidewalks for pedestrians, disabled persons or bicyclists. The Contractor is restricted from storing any materials, construction traffic control devices, signs, etc. in any median area or park area.
12. Vertical cuts or fills greater than 1 inch resulting from construction operations adjacent to traffic lanes, or within the clear zone shall be temporarily sloped at a 6:1 or flatter slope, and delineated at 35 foot intervals immediately after removal operations to safeguard the traveling public.
13. Construction equipment used on this project shall meet the same minimum exhaust requirements as those specified by the manufacturer of the equipment.

-3-

**REVISION OF SECTION 630
CONSTRUCTION ZONE TRAFFIC CONTROL**

14. The Contractor and subcontractors shall equip their construction vehicles with flashing amber lights. Equipment to be used at night shall also be equipped with flashing amber lights. Flashing amber lights on vehicles and equipment shall be visible from all directions.
15. The Contractor shall maintain access to all roadways, side streets, walkways, alleyways, driveways, and hike/bike paths at all times unless otherwise directed by the Project Manager. Parking areas temporarily disturbed by construction activities shall be restored to a useable condition during non-working hours. Such temporary parking shall utilize an all-weather surface. The Contractor shall work with the Program-wide Traffic Control Contractor to develop an Access Maintenance Plan in coordination with, and based on the requirements of, the affected property owners and tenants, and submit it to the Project Manager for approval prior to commencement of work. This plan shall detail all barricades, ramps, signs, and temporary means of access required by the property owners or tenants. Prior to commencing any work which affects access to a property, the Access Maintenance Plan for that property must be submitted and approved by the Project Manager.
16. The Access Maintenance Plan shall be coordinated with all affected owners and tenants. The Access Maintenance Plan shall include documentation of this coordination, including the approval signature of each affected owner or tenant. Should the Contractor be unable to obtain approval and signatures, documentation of the efforts made to obtain said approval and signatures must be submitted. All access shall be maintained on surfaces equal to or better than those existing at the time the access is first disturbed. For short periods of time only as allowed by the Project Manager, access may be maintained on an aggregate base course surfaces.

The Contractor shall maintain continuous access throughout the project for pedestrians, bicyclists, and disabled persons. When the existing access route is disturbed by construction, a temporary all-weather access shall be provided. All temporary access shall be a minimum of 5 feet wide and meet Americans with Disabilities Act (ADA) requirements. Acceptable all-weather surfacing shall be concrete or asphalt surface, or as approved by the Project Manager. Delineation of pedestrian access through the work area shall be accomplished using temporary plastic fencing.
17. The costs of maintaining access will not be paid for separately, unless otherwise provided, but shall be included in the work. Utilization of materials to be incorporated into the work may be permitted. However, any degradation or other contamination or destruction shall be corrected at the Contractor's expense prior to acceptance.
18. During non-construction periods (evenings, weekends, holidays, etc.) all work shall be adequately protected to ensure the safety of vehicular and pedestrian traffic, as detailed in the Contractor's MHT. Excavations or holes shall be filled in or fenced when unattended.
19. Whenever the Contractor removes, obliterates, or overlays any pavement markings, they shall be replaced on a daily basis prior to opening the affected areas to traffic. All temporary pavement markings shall fully comply with the Standard Specifications and Special Provisions.
20. Any existing pavement markings that conflict with temporary or permanent pavement markings shall be completely removed.
21. The Contractor shall not have construction equipment or materials in the lanes open to traffic any time unless directed by the Project Manager.

-4-

**REVISION OF SECTION 630
CONSTRUCTION ZONE TRAFFIC CONTROL**

22. All personal vehicle and construction equipment parking is prohibited where it conflicts with safety, access, or the flow of traffic. Landscaped areas, public park areas, and roadway shoulders shall be kept clear of parking and storage of all personal and construction equipment except where approved by the Project Manager.
23. The Contractor shall not place tack coat on any surface to be paved where traffic will be forced to travel upon fresh bituminous materials.
24. The Contractor shall be required to maintain temporary drives at any existing establishment that has singular access off of the roadways, unless otherwise approved in writing by the property owner.
25. No work that interferes with traffic will be allowed on holidays or any day of a three-day or four-day weekend that includes a holiday. Holidays on which this restriction applies consist of those holidays recognized by the City & County of Denver.
26. During no-working hours, the roadways shall be restored to a safe travel condition for the free flow of traffic. Any maintenance required restoring the roadways to this condition, including the pavement patching and grading, shall be done prior to opening the areas to traffic or completing work for the day.
27. The Contractor shall clean the roadway of all construction debris before opening it to traffic.
28. All flagging stations used at night shall be illuminated with floodlights. Street, highway lights and "high mast lighting" may be used for flagging station illumination when approved by the Project Manager. Floodlights shall be located and directed so as not to interfere with the sight of any motorists, and the cost to be included in the work.
29. Prior to removal and resetting of any sign the Contractor and Project Manager shall prepare an inventory. Any signs damaged due to the Contractor's operations shall be replaced in kind or repaired by the Contractor at no additional cost to the project.
30. Unless noted otherwise, all costs incidental to the foregoing requirements shall be included in the original contract prices for the project, including any additional traffic control items required for haul routes into the project.

Subsection 630.10 (10) shall be added as follows:

Contractor shall obtain all required access and construction permits from the City & County of Denver prior to initiating work along City right of way.

All lane closures require an arrow board to be installed.

Subsection 630.15 is hereby deleted and replaced with the following:

Temporary pavement markings for traffic control will not be measured and paid for separately, but shall be included in the work.

-5-

**REVISION OF SECTION 630
CONSTRUCTION ZONE TRAFFIC CONTROL**

Subsection 630.17 is hereby deleted and replaced with the following:

Construction Traffic Control will not be measured for payment, but shall be paid on a lump sum basis.

All costs incidental to maintenance of access will not be paid for separately, but shall be included in the work.

All costs incidental to the foregoing requirements shall be included in the original contract prices for the project.

Subsection 630.18 is hereby deleted and replaced with the following:

Payment will be made under:

| Item | Pay Unit |
|-----------------|-----------------|
| Traffic Control | Lump Sum |

All costs associated with Construction Traffic Control shall be included in the work.

END OF SECTION

**REVISION OF SECTION 630
PORTABLE MESSAGE SIGN PANEL**

Section 630 of the Standard Specifications is hereby revised for this project as follows:

Subsection 630.01 shall include the following:

This work shall consist of furnishing, operating, and maintaining portable message sign panels, to be on the project site at least two weeks prior to the start of active roadway construction.

Subsection 630.03 shall include the following:

Portable message sign panels shall be furnished as a device, fully self-contained on a portable trailer, capable of being licensed for normal highway travel, and shall include leveling and stabilization jacks. The panel shall display a minimum of three (3), eight-character lines. The panel shall be a dot matrix type LED legend or approved alternate, on a flat black background. LED signs shall have a pre-default message that activates before power failure. The sign shall have its own separate power source with independent back-up battery power. The sign shall be capable of 360 degrees horizontal rotation and be able to be elevated to a height of at least five feet above the ground surface as measured to the bottom of the sign. The sign should be visible from one-half mile under both day and night conditions. The message should be legible from a minimum of 750 feet. The sign shall automatically adjust its light source to meet legibility requirements during the hours of darkness. The sign enclosure shall be watertight and provide a clear polycarbonate front cover.

Solar powered message signs shall be capable of operating continuously for ten days without sun. All instrumentation and controls shall be contained in a lockable enclosure. The sign shall be capable of changing and displaying sign messages and other sign features such as flash rates, moving arrows, etc.

Each sign shall conform to the following:

1. In addition to the onboard solar power operation with battery back-up, each sign shall be capable of operating on a hard-wire, 100-110 VAC external power source.
2. All electrical wiring including connectors and switch controls necessary to allow all sign functions required by the specification shall be provided with each sign.
3. Each sign shall be furnished with an operating and parts manual, wiring diagrams, and troubleshooting guide.
4. The portable message sign shall be capable of maintaining all required operations under Colorado mountain/winter weather conditions.
5. Each sign shall be furnished with an attached license plate and mounting bracket.
6. Each sign shall be wired with a 7-prong male electric plug for the brake light warning system.

Subsection 630.13 shall include the following:

The portable message sign panel shall be on the project site at least 14 calendar days prior to the start of active roadway construction. Maintenance, storage, operation, relocation to different sites during the project, and all repairs of portable message sign panels shall be the responsibility of the Contractor.

Contract Control No. 2021-PROJMSTR-0000693

May 24, 2022

Subsection 630.18 shall include the following:

Portable message sign panels will not be measured and paid for separately but shall be included in the item Traffic Control.

Maintenance, storage, operation, relocation to different sites during the project, and all repairs of portable message signs shall be the responsibility of the Contractor and will not be measured and paid separately.

END OF SECTION

**REVISION OF SECTION 622
SITE FURNISHINGS**

Section 622 of the Standard Specifications is deleted and replaced as follows:

622.01 DESCRIPTION

Provide, install and warranty site improvements and furnishings complete as shown on the drawings and as specified herein. Work of this Section includes benches, bike racks and trash receptacles.

QUALITY ASSURANCE

A. Applicable Standards: Apply the current or latest editions of the standards described below:

ACI - American Concrete Institute, Manual for Concrete Practice.

ASTM - American Society for Testing and Materials

UBC - Uniform Building Code

CPSC – U.S. Consumer Product Safety Commission

City and County of Denver: Streetscape Guidelines and Public Works requirements with respect to work in the public Right of Way.

B. Compatibility with Adjacent Materials: Verify that all site furnishings are coordinated with other site improvements either completed or planned, and that installation shall not adversely affect other site improvements.

C. Qualifications:

1. Installer of site furnishings shall demonstrate successful continuous experience in site work furnishing fabrication and installations similar to the work of this project for a period of not less than five (5) years.
2. Installer Qualifications: An experienced installer who has completed Work similar in material, design, and extent to that indicated for this Project and whose work has resulted in construction with a record of successful in-service performance.
3. Material Certificates: Signed by manufacturers certifying that each of the following items complies with requirements: Anti-graffiti Sealant.
4. Professional Engineer for review of all structural elements as required shall be a professional engineer who is legally qualified to practice in jurisdiction where the Project is located (Colorado) and shall be experienced in providing engineering services of the type indicated. Engineering services are defined as those performed for final design of structural foundations for concrete planter.

SUBMITTALS

A. Samples and Product Data: Submit samples and/or manufacturer's current literature for the specified items including:

1. Catalog cuts and actual color/finish samples for each type of furnishing and anti-graffiti sealant.
2. Dimensioned drawings showing proposed installation method for each piece furnished.

-2-

**REVISION OF SECTION 622
SITE FURNISHINGS**

3. Manufacturer's installation instructions and maintenance requirements.

PRODUCT DELIVERY, STORAGE AND HANDLING

- A. Labeling: Furnish standard products in unopened manufacturer's original containers bearing original labels showing quantity, description and name of manufacturer.
- B. Delivery: Deliver and unload at the site on pallets and bound in such a manner that no damage occurs to the product.
- C. Storage: Store products in a manner that will preclude all damages. Damaged materials will be rejected. Remove all damaged materials from the job site immediately and replace at no cost to Owner.
- D. Handling: Furnish suitable equipment to locate all site furnishing materials carefully and efficiently. Lift materials using lifting inserts provided by manufacturer where applicable.

622.02 Materials**Site Furnishings**

- A. Bench Topper:
Supplier: Site Pieces, or approved equal
1. Product: ML-TOP
 2. Description: 6' Flat Topper Bench
 3. Size: 72"x 21" x 2" H
 4. Color: Dark Bronze
 5. Material: TMA-Thermally Modified Ash Slats
 6. Contact: Site Pieces, Inc., Mike Honerlaw, 720.665.5251, mike@sitepieces.com
- B. Stacked Timber Bench:
Supplier: Streetlife, or approved equal
1. Product: Drifter Structure DB-STR-H2-800-160-PC-UH
 2. Description: Large multi-tiered seating bench
 3. Size: 63" W x 315" L x 32.9" H
 4. Color: Powdercoated Steel Supports, color TBD
 5. Material: Upcycled Hardwood
 6. Contact: TBD

-3-

**REVISION OF SECTION 622
SITE FURNISHINGS****C. Timber Bench:**

Supplier: Streetlife, or approved equal

1. Product: Drifter Bench DB-L1-300-PC-UH
2. Description: Seating bench
3. Size: 12" W x 118" L x 19" H
4. Color: Powdercoated Steel Supports, color TBD
5. Material: Upcycled Hardwood
6. Contact: TBD

D. Freestanding Planter

Supplier:

1. Tournesol , or approved equal
 - a. Type A
 1. Model: Willshire Steel Planter
 2. Size: 18"w x 72" l x 30" h
 3. Finish: Cedar Bronze
 - b. Type B
 1. Model: Boulevard Planter
 2. Size: 24"W x 72"L x 30" h
 3. Finish: Ipe

E. Bicycle Rack

Supplier:

1. Doro, or approved equal
2. Model: Hoop Rack
3. Finish: Stainless
4. Mounting: In-Ground

F. Anti-Graffiti Sealant

1. Sealant for the exposed finish of all exposed architectural cast-in-place concrete or stone surfaces:
 - a. Sure Klean Weather Seal "Blok-Guard & Graffiti Control" water and oil repellant as manufactured by: ProSoCo Inc., Kansas City, KS.: a clear solvent-based silicone elastomer formulated to weatherproof concrete block and other porous masonry surfaces from repeated graffiti attacks without altering the natural appearance.
 - b. Sealer shall not produce any visible color change to cast-in-place concrete or stone following application.

-4-

**REVISION OF SECTION 622
SITE FURNISHINGS**

622.03 Construction requirements**GENERAL**

- A. Acceptance: Do not install site furnishings prior to acceptance of finished grade in area to receive such materials.
- B. Locations: Install as shown on the Drawings, per the manufacturer's instructions or as directed by the Owner's Representative.
- C. Special Precautions: Protect against damage of adjacent pavements and plantings where site furnishings are to be installed.

SITE FURNISHINGS

- A. Layout: Final locations of all site furnishings shall be approved by the Landscape Architect.
- B. Attachment: All site furnishings shall be permanently secured by means of foundations, footings and or corrosion resistant anchors as shown on the plans and in accordance with the manufacturer's requirements. Spot weld anchor bolts to prevent unauthorized removal. Do not damage furnishings during attachment.
- C. Fabrication: All furnishing shall be shop fabricated and delivered to the site in protective containers to reduce the chance of damage prior to installation.

CLEAN-UP

- A. Keep all areas of work clean, neat and orderly at all times.
- B. Clean up and remove all debris from the entire work area to satisfaction of Owner's Representative Architect prior to Final Acceptance.

622.04 Measurement and Payment

Work of each item shall include concrete footings, anchors, form-work and anchor bolts as required to complete the work in accordance with the plans and specifications and to conform with manufacturer's installation instructions, and all incidental items required for a complete and functional installation.

| Pay Item | Pay Unit |
|-------------------------------|-----------------|
| Bench Topper | Each |
| Timber Bench | Each |
| Stacked Timber Bench | Each |
| Freestanding Planter (Type _) | Each |
| Bicycle Rack | Each |

END OF SECTION

Contract Control No. 2021-PROJMSTR-0000693

May 24, 2022

**REVISION OF SECTION 708
STRUCTURAL CONCRETE COATING**

Section 708 of the Standard Specifications is hereby revised for this project as follows:

Subsection 708.08 shall include the following:

All exposed concrete bridge surfaces including girders, edge of deck, railing curb, wingwalls and abutments shall be coated the following color:

RAL 7035 Light Grey

A 4'x4' sample section of the coating shall be installed for review and approval prior to installation on entire project. Sample section may be incorporated into the work.

END OF SECTION

**DENVER (ONLY) NOISE ORDINANCE – PERMIT
VARIANCE APPLICATION TEMPLATE**

Date:

Subject: **Request for Variance to Noise Ordinance**

[location where work is to be performed]

Dear Ms. VanDerLoop,

- Name of company/organization seeking the variance
- What is being proposed, where it will occur, expected duration of project
- Brief history regarding proposed project
- Description of the community in the vicinity of the proposed project area

6 (a) Type and Timing of Claim:

- Specific description of proposed project (figures are helpful)
- Why does work need to be conducted at night? (CDOT can provide details to contractor)
- Are there limiting factors preventing this work from being conducted during the day? (CDOT can provide details to contractor)
- Requested variance duration; start and end dates
- Proposed work hours
- Types/categories of equipment being used for the project (if known, a detailed list should be provided as an appendix)
- Is this variance request contingent on other regulatory approvals/permits? (construction, demo, remediation)

6 (b) Date of Payment:

- [The Company's] date of payment is the date shown of this letter/request.

6 (c) Objections to Manager's Determinations:

- Specific items applicant may be in disagreement with concerning Department's recommendations or requirements

6 (d) (1) Hardship if Variance is Not Granted:

- Public safety concerns (CDOT can provide details to contractor)
- Logistical concerns
- Time constraints with a detailed explanation as to why they are necessary
- Cost considerations (specifics desirable)
- Document and evaluate possible alternatives

6 (d) (2) No Adverse Affects to Public Health:

- List expected noise levels to be generated (1) at the site where work is being performed, and (2) at the nearest sensitive receptor (CDOT can provide details to contractor from Roadway Construction Noise Model)
- Detail existing ambient sound levels (L90, Leq, Lmax) for the same areas (at least 1 night of pre-work monitoring; 9 p.m. to 7 a.m.; two nights (one weekday, one weekend) if work will occur on weekdays and weekends)
- How do the proposed levels compare with existing EPA or other guidance? (CDOT can provide details to contractor)
- Are there adverse health effects other than noise to be concerned with as a result of the proposed work? (CDOT can provide details to contractor)

-2-

**DENVER (ONLY) NOISE ORDINANCE – PERMIT
VARIANCE APPLICATION TEMPLATE**

6(d) (3) Maintain Harmony with the Spirit and Purpose of the Ordinance:

(CDOT can provide details to contractor for sec 6(d) (3))

- Is the scope of work considerate of present and future community concerns?
- How does the scope of work seek to minimize impacts to the community?
- Have noise mitigation techniques been included and/or considered?
- Has a noise monitoring plan been considered or proposed?
- How will community outreach be conducted prior to the start of work?
- Has a community response plan been developed to deal with any future complaints? (contact name and number of on-site representative)

6 (e) Project Location and Haul Routes:

- Figures are preferable (CDOT can provide details to contractor)

6 (f) Petitioner Information

[Company Name and Address]

[Contact Person/Project Manager info]

6 (g) Petitioner's Signature

Sincerely,

[Name and Title]

Note: In addition to this template, CDOT can provide an example of a previously written (City and County of Denver) variance application at the contractor's request.

The following field work summary of requirements will be the sole responsibility of the contractor for maintaining compliance with the Denver (only) Permit Variance agreements once granted by the Department of Environmental Health.

- 1) **Construction Activity Allowable Noise Levels:** Unless the accommodations described in below are provided, construction noise levels shall not exceed:
 - a. an hourly Leq of 75 dBA, or 5 dBA greater than an ambient hourly Leq measuring more than 75 dBA, or
 - b. an Lmax of 86 dBA during the hours of 9:00 p.m. to 7:00 a.m. (Nighttime Hours)
- 2) **Hotel accommodations within eligibility zones:** (Contractor) shall make hotel accommodations available for persons residing within eligibility zones where Nighttime construction noise levels exceed allowable noise levels. The eligibility zone shall be determined by a sound study conducted by the (contractor) and approved by DEH prior to a seven-day notification period. During nighttime construction, (contractor) shall conduct noise monitoring to verify the sound study results and shall expand and may restrict the eligibility zone to the areas where the actual noise levels exceed an hourly Leq of 75 dB(A) or an Lmax of 86 dB(A). (Contractor) shall consider any special circumstances brought to their attention regarding individuals in the eligibility zone who cannot utilize hotel vouchers and who may be at risk during this period of time, e.g., residents of 24-hour health care facilities. (Contractor) shall make their best effort to accommodate the needs of such individuals during Construction Activity.

-3-

**DENVER (ONLY) NOISE ORDINANCE – PERMIT
VARIANCE APPLICATION TEMPLATE**

- 3) **Notifications:** Not less than seven days prior to commencement of construction during Nighttime Hours, (contractor) shall notify individual households located within a 1000 foot radius of the construction, as well as representatives of each affected Registered Neighborhood Organizations. Notice shall be in writing or by direct personal contact from (contractor) representative, and shall include the expected start time, expected duration, character of work activity planned, names and telephone numbers of available contact persons (for additional information or questions), contact numbers for complaints, and any other relevant parameters or programs. Households within the eligibility zone shall receive notice regarding their eligibility for hotel vouchers at the same time or earlier.
- 4) **Mitigation Requirements/Activity Restraints:** When construction is conducted during Nighttime Hours and such activity emits noise levels that exceed ambient noise levels at residential properties, (contractor) shall utilize best reasonable management practices to mitigate construction noise impacts to the adjacent property owners. Best reasonable management practices include the following:
- a. Using reasonable best efforts to complete the construction as quickly as possible.
 - b. Minimizing nighttime construction duration near residential areas whenever possible.
 - c. Re-routing of truck traffic away from residential streets when possible.
 - d. Conducting truck loading, unloading and hauling operations so that noise levels are kept to a minimum
 - e. Configuring equipment on the site to minimize back-up alarm noise, where practical and feasible (for example, by using circular movement of trucks).
 - f. Shielding jackhammers, saws, and pavement breakers through use of an existing sound barrier wall or temporary barrier where practicable
 - g. Maintaining all equipment to meet manufacturer’s specifications.
 - h. Informing employees, contractors and subcontractors performing construction of the general requirements of this variance and exercising best efforts to ensure that such employees, contractors and subcontractors follow best management practices in mitigating construction noise.
- 5) **Monitoring:** (Contractor) shall perform monitoring sufficient to demonstrate compliance with the requirements of the noise variance and to demonstrate to the community the noise levels that are present.
- a. Noise measurements shall be collected using ANSI guidelines for community noise monitoring
 - i. Manufacturer’s specifications for appropriate meter use shall be followed.
 - ii. All noise measurements shall be made using the A-weighted scale (dB(A)) and a slow response. Fast response measurements may be used to measure impact noise levels.
 - iii. Noise measurements shall be made at the nearest residential property line, unless physically impractical.
 - b. All nighttime construction activity shall be initially monitored. Monitoring shall include spot measurements, as appropriate and hourly Leq. Monitoring shall be required for the following activity groups, but not be limited to:
 - i. Joint Repair
 - ii. Milling Operations
 - iii. Rubble load-out
 - iv. Paving operations
 - c. Monitoring shall meet the following requirements:
 - i. Each construction activity shall be monitored a minimum of two days for Lmax and hourly Leq levels to establish an activity baseline for each activity when initially undertaken, and to establish the expected worst case situation (outside lane).
 - ii. Noise monitoring shall be provided in response to all noise complaints.

-4-

**DENVER (ONLY) NOISE ORDINANCE – PERMIT
VARIANCE APPLICATION TEMPLATE**

- iii. All noise monitoring data and documentation shall be provided to DEH at least weekly when applicable, and such data shall be available to the public from DEH. DEH and their designated representatives may inspect collected data more frequently.
 - d. The following documentation, in a manner and form mutually agreed upon by City/County of Denver, (contractor) and DEH, shall be provided for noise monitoring that is conducted:
 - i. Manufacturer names, model numbers, and serial numbers of each SLM and acoustical calibrator used.
 - ii. Software manufacturer, program and version.
 - iii. Dates of annual certified calibration of SLM, microphone and acoustical calibrator.
 - iv. Pre- and post- monitoring calibration data for the Sound Level Meter.
 - v. Date and specific location (address if appropriate) of monitoring.
 - vi. Start time and end time of monitoring
 - vii. Ambient weather conditions including temperature, relative humidity, wind speed and cloud cover.
 - viii. Signature of technician collecting the data
 - ix. List of each hourly Leq for the monitoring period, with associated Lmax levels.
 - x. All measurements associated with any unusual noise events that occurred, cause of such event if known, correction of such event (if any), and adjusted and unadjusted measurements.
- 6) **Complaint Notification and Response:** (Contractor) shall ensure that methods are available to receive, address, and respond to concerns raised by people in the community, through:
- a. Assuring that a field representative is available to respond to complaints regarding construction noise levels and provide monitoring. The field representative shall be empowered to shut down construction activity, authorize correction or remediation of sources of excess noise, and authorize resumption of construction activity as necessary to maintain compliance with allowable noise levels.
 - b. Providing telephone access to a field representative during hours of project activities to receive complaints or comments from the public for the duration of the project. All complaints immediately shall be recorded, investigated and addressed as appropriate by the field representative and reported to DEH in a manner mutually agreed by DEH, City/County of Denver and (contractor). A response, in a reasonable form requested by the caller, summarizing the investigation and any corrective actions taken by City/County of Denver and (contractor) shall be provided to the caller. Written copies of complaints received and responses by (contractor) shall be provided weekly to DEH and CDOT.

All application requirements and chapter 36 ordinance requirements regarding night time construction noise activities must be coordinated by the contractor with the City/County Denver. The contractor is fully responsible for the timely submittal of the variance application and fulfilling the requirements set forth by the City/County of Denver to allow construction activities during p.m. hours under the granted variance.

END OF SECTION

UTILITIES

Known utilities within the limits of this project are:

| UTILITY COMPANY ADDRESS | CONTACT NAME EMAIL | TELEPHONE |
|---|---|------------------|
| AT&T 619 W. Bannock Street, Rm 342 Boise, ID 83702 | Chris Tone ct4169@att.com Ian Wetteland (Field) iw1368@att.com | 303-944-2209 |
| Denver Traffic 5440 N. Roslyn Street Denver, CO 80126 | Joshua Jones joshua.jones2@denvergov.org | 435-512-3229 |
| Denver Wastewater Management Division 201 W. Colfax 5.C.5-5 Denver, CO 80202 | Rick Abeyta Richard.abeyta@denvergov.org | 303-446-3529 |
| Denver Water 1600 West 12th Avenue Denver, CO 80204 | Kela Naso kela.naso@denverwater.org | 303-628-6302 |
| Lumen 5325 Zuni Street Denver, CO 80221 | Justin Metzler (TerraTech) jmetzler@terratech.com | 303-525-7086 |
| Xcel Energy – Electric and Gas 5460 W. 60 th Avenue Arvada, CO 80003 | Alex Speer Alex.M.Speer@xcelenergy.com | 720-670-7501 |
| Xcel Energy – Builder Call Line Application for Gas and Electric Service | bclco@xcelenergy.com | 1-800-628-2121 |

The work described in these plans and specifications requires coordination between the Contractor and the utility companies in accordance with subsection 105.11 in conducting their respective operations as necessary to complete the utility work with minimum delay to the project.

-2-
UTILITIES

PART 1 - CONTRACTOR SHALL PERFORM THE WORK LISTED BELOW:

Coordinate project construction with performance by the utility owner of each utility work element listed in Part 2 below. Perform preparatory work specified in Part 2 for each utility work element. Provide an accurate construction schedule that includes all utility work elements to the owner of each impacted utility. Provide each utility owner with weekly updates to the schedule. Conduct necessary utility coordination meetings, and provide other necessary accommodations as directed by the Engineer. Notify each utility owner in writing, with a copy to the Engineer, prior to the time each utility work element is to be performed by the utility owner. Provide notice, as specified in Part 2, immediately prior to the time the utility work must begin to meet the project schedule.

Provide traffic control, as directed by the Engineer, for any utility work performed by the utility owner within the project limits expected to be coordinated with construction. However, traffic control for utility work outside of typical project work hours shall be the responsibility of the utility owner.

Perform each utility work element for every utility owner listed in Part 1. Notify each utility owner in advance of any work being done by the Contractor to its facility, so that the utility owner can coordinate its inspections for final acceptance of the work with the Engineer. Obtain written acceptance from the utility owner for work performed by Contractor.

The Contractor shall remove all abandoned utility facilities as necessary to accommodate construction.

Project Limits - All Utility Companies

Prior to excavating, the Contractor shall positively locate (through potholing if necessary) all potential conflicts with existing underground utilities and proposed construction, as determined by the Contractor according to proposed methods and schedule of construction. The Contractor shall modify construction plans to avoid existing underground facilities as needed, and as approved by the Engineer. Please note that Colorado811 notifies member utilities, who are then responsible for marking their own facilities – Other facilities, such as ditches and drainage pipes may exist, and it is the Contractor's responsibility to investigate, locate and avoid such facilities.

AT&T

The Contractor shall notify AT&T one (1) week in advance of construction operations commencing near AT&T facilities.

The Contractor shall protect in place the AT&T facilities located along the project corridor and shall coordinate with AT&T if any facility is found to be in conflict. If a relocation, adjustment, or support is necessary, the Contractor shall coordinate with AT&T to schedule and facilitate the work by AT&T forces.

Denver Department of Transportation and Infrastructure (DOTI) - ITS

The Contractor shall notify the DOTI - ITS one (1) week in advance of construction operations commencing near DOTI facilities.

The Contractor shall coordinate with DOTI - ITS for work to be done at each intersection as shown in the Traffic Signal Plans. The contractor will be responsible for the installation, adjustment, and reconfiguration of ITS facilities as shown on the plans.

-3-
UTILITIES

Denver Wastewater Management

The Contractor shall notify the Denver Wastewater one (1) week in advance of construction operations commencing near Denver Wastewater facilities. The Contractor shall maintain access to existing sanitary manholes at all times during construction.

The Contractor shall coordinate with the Denver Wastewater if any facility is found to be in conflict. If a relocation, adjustment, or support is necessary, the Contractor shall coordinate with Denver Wastewater Management to schedule and facilitate the work by Contractor forces.

The Contractor shall coordinate inspections with Denver Wastewater. The Contractor shall provide the utility owner written notice 5 days immediately prior to required inspections.

Denver Water

No work shall commence on Denver Water facilities until a pre-construction meeting is held with a Denver Water inspector.

The Contractor shall arrange for a Pre-Construction conference with Denver Water Department forces.

The Contractor shall clean and adjust the water valves in 14th Street to final grade, as shown on the plans.

The Contractor shall coordinate inspections and outages with Denver Water Department forces. The Contractor shall provide Denver Water written notice forty-eight (48) hours immediately prior to required inspections.

The Contractor shall coordinate with the Denver Water if any facility is found to be in conflict. If a relocation, adjustment, or support is necessary, the Contractor shall schedule and facilitate the work by Contractor forces.

Lumen

The Contractor is not required to notify Lumen in advance of construction operations commencing near abandoned Lumen facilities.

The Contractor may remove abandoned Lumen facilities as needed during construction and shall coordinate with Lumen if any other facility is found to be in conflict with construction. If a relocation, adjustment, or support is necessary, the Contractor shall coordinate with Lumen to schedule and facilitate the work by Lumen forces. The Contractor shall provide Lumen two (2) weeks notice if a Lumen facility is found to be in conflict.

-4-
UTILITIES

Xcel Energy – Electric Distribution/Lighting/Traffic

The Contractor shall call the Builder's Call Line ninety (90) days prior to construction at 1-800-628-2121.

The Contractor shall notify Xcel Energy one (1) week in advance of construction operations commencing near Xcel Energy electric facilities.

The Contractor shall be responsible for the coordination of power source work to be performed by Xcel Energy. The Contractor shall complete and submit a Builder's Call Line (BCL) Application/Request for electrical services for every Xcel Energy work element that is to be coordinated with the project. A separate application is required for each electrical service, demolition work, pedestrian lights, underdeck lights, and streetlight work. The request is to be processed through Xcel Energy's Builder's Call Line at 1-800-628-2121 or <https://my.xcelenergy.com/BuildingRemodeling/s/>. The name of the owner for each meter or flat-rated service shall be the owner's name and billing address responsible for paying the utility bill and shall be listed on the BCL application. The Contractor shall be listed as the Builder and the contact during construction on the BCL application. The Contractor shall perform the required coordination to establish the power sources for pedestrian lighting, street lighting, underdeck lighting, various other equipment that requires electrical service and traffic signals as shown on the plans. The Contractor shall perform all work necessary to maintain existing or establish new power sources to the devices called for in the plans and per the standard for any metered or flat-rated services. The Xcel Energy portion of this work shall be completed within the time frames set forth in the franchise agreement in a manner that does not interfere with the project construction activities of the City and County of Denver.

To facilitate coordination with Xcel Energy, the City has submitted Work Requests to Xcel for the installation of new traffic signal services, removal of existing traffic signal services, poles, luminaires, streetlights, pedestrian lights and feed, and installation of new pedestrian lights, underdeck lights, and streetlight.

The Contractor shall coordinate with Xcel Energy if any facility is found to conflict with the proposed roadway improvements. If a relocation, adjustment, or support is necessary, the Contractor shall coordinate with Xcel Energy to schedule and facilitate the work by Xcel Energy forces. If no conflicts are identified, the Contractor shall protect the electrical facilities in place while work is being conducted in the immediate area.

The contractor shall coordinate with Xcel Energy regarding the removal and installation of new Xcel electric facilities in the project's construction limits by Xcel Energy Forces.

Xcel Energy – Gas Distribution

The Contractor shall call the Builder's Call Line ninety (90) days prior to construction at 1-800-628-2121.

The Contractor shall notify Xcel Energy thirty (30) days in advance of construction operations commencing near Xcel Energy gas facilities. The Contractor shall coordinate with Xcel Energy if any facility is found to be in conflict with the proposed roadway improvements. If a relocation, adjustment, or support is necessary, the Contractor shall coordinate with Xcel Energy to schedule and facilitate the work by Xcel Energy forces. If no conflict is identified, the Contractor shall protect the facility in place while work is being conducted in the immediate area.

-5-
UTILITIES

An Xcel Energy Gas Operations representative shall be present during all work near and surrounding the intermediate pressure gas pipelines. The Contractor shall adhere to the recommendations provided by the Xcel Energy representative. The Contractor shall protect-in-place the intermediate pressure gas pipelines during all construction activities. The protection in place will not be paid separately but shall be included in the work.

The Xcel Energy Gas Operations representative will inspect the pipe prior to and after completion of the work to ensure the integrity of the pipeline and the pipeline coating if coating is present. The Contractor shall be responsible for any repairs necessary if the Xcel Operations representative discovers damage caused by the construction work.

The Xcel Energy Gas Operations representative shall not be paid for separately but shall be included in the work.

PART 2 - UTILITY OWNERS SHALL PERFORM THE WORK LISTED BELOW:

Although the Contractor shall provide traffic control for utility work expected to be coordinated with construction, traffic control for utility work outside of typical project work hours or outside of project limits shall be the responsibility of the utility owner. The utility owner shall prepare and submit to the Engineer a Method of Handling Traffic for utility work to be performed outside typical project work hours or outside of project limits. The utility owner shall obtain acceptance of the Method of Handling Traffic from the Engineer prior to beginning the utility work to be performed outside typical project work hours or outside of project limits.

This work will be performed by the utility owners as necessary to avoid conflicts with construction activities. New locations shall be as indicated in the plans. Utility owners shall comply with schedule requirements of the Contractor and make every effort not to impact the overall construction schedule. Unless otherwise approved by the Engineer, abandoned aboveground appurtenances such as pedestals shall be removed and abandoned underground utilities and manholes/handholds shall be abandoned in place.

Utility owners are responsible for obtaining all necessary permits from the City and County of Denver, as required.

AT&T

AT&T shall coordinate with the Contractor regarding AT&T's facilities in the project limits if a relocation, adjustment, or support is necessary to schedule and facilitate the work by AT&T forces.

Denver Wastewater Management

Denver Wastewater shall inspect utility work performed by the Contractor listed in Part 1 above. The Contractor shall provide the utility owner written notice five (5) days immediately prior to each required inspection.

Denver Water

Denver Water forces shall inspect utility work performed by the Contractor listed in Part 1 above. The Contractor shall coordinate inspections with the Denver Water forces. The Contractor shall provide the utility owner written notice forty-eight (48) hours immediately prior to required inspections.

-6-
UTILITIES

Xcel Energy – Electric Distribution/Lighting/Traffic

Xcel Energy shall coordinate with the Contractor regarding Xcel's electric facilities in the project limits and shall remove the facilities as needed.

Xcel Energy shall remove the existing pedestrian lights and electric feeds on Larimer St. between southbound Speer Blvd. and 14th St. The Contractor shall install new pedestrian lighting and electrical feeds to be inspected and turned over to Xcel as shown on the plans.

Xcel Energy shall remove the existing streetlight and electrical feed on Larimer St. between Cherry Creek and 14th St. The Contractor shall install a new streetlight and electrical feed to be inspected and turned over to Xcel as shown on the plans.

Once the proposed traffic signals, including luminaires, conduits and wiring to the proposed meters/disconnects, have been installed by the Contractor as shown on the plans, Xcel Energy forces shall make the final connections to the metered power sources. Xcel shall provide power sources for streetlights, pedestrian lights, and traffic signals.

The above work items are expected to be coordinated with construction.

Xcel Energy – Gas Distribution

Xcel Energy shall coordinate with the Contractor to protect in place Xcel facilities as follows:

- Xcel's 4" steel gas main at Larimer St. and Speer Blvd., where they will be near the proposed sidewalk/roadway construction.
- Xcel's 10" steel gas main on 14th St., where they will be near the proposed roadway construction.
- Xcel's 2" steel gas main on Larimer St. between Cherry Creek and 14th St., where they will be near the proposed sidewalk/roadway construction.

If no adjustment by Xcel is required, the Contractor shall notify Xcel one (1) week in advance of construction. If Xcel needs to adjust, relocate, or support the facility, it is expected to take eight (8) weeks for design and construction.

GENERAL:

The Contractor shall comply with Article 1.5 of Title 9, CRS ("Excavation Requirements") when excavating or grading is planned in the area of underground utility facilities. The Contractor shall notify all affected utilities at least two (2) business days, not including the actual day of notice, prior to commencing such operations. The Contractor shall contact Colorado811 at phone no. **811 or 1-800-922-1987**, to have locations of Colorado811 registered lines marked by member companies. All other underground facilities shall be located by contacting the respective owner. Utility service laterals shall also be located prior to beginning excavation or grading.

Utilities are depicted on these plans in accordance with their achieved "Quality Level" as defined in the American Society of Civil Engineer's document ASCE 38, "Standard Guideline for the Collection and Depiction of Existing Subsurface Utility Data". Reliance upon this data for risk management purposes during bidding does not relieve the excavator or utility owner from following all applicable utility damage prevention statutes, polices, and/or procedures during excavation.

Contract Control No. 2021-PROJMSTR-0000693

May 24, 2022

-7-
UTILITIES

The contractor's attention is directed to Standard Specifications for Road and Bridge Construction subsection 105.11. No guarantee is made that utility conflicts will be resolved prior to construction activities and any delays resulting from utility relocation work shall be dealt with in accordance with subsection 108.08 of the Standard Specifications for Road and Bridge Construction as amended.

All costs incidental to the foregoing requirements will not be paid for separately but shall be included in the work.

END OF SECTION

Contract Control No. 2021-PROJMSTR-0000693

May 24, 2022

FORCE ACCOUNT AND ALLOWANCE ACCOUNT ITEMS**DESCRIPTION**

This special provision contains the City and County's estimate for force account and allowance account items included in the Contract. Force account and allowance account work shall be performed as directed by the Engineer.

Force account items shall be for needed items that have a cost from a third party such as a Tap Fees or added permits.

Generally, estimated allowance account amounts are for anticipated work with unknown quantities or unknown scope that will be later negotiated by the Engineer once quantities are known. The Contractor will solicit bids and provide a cost to perform once the quantity is known. Allowance items will be included in the total bid to determine the project commitment and the amount of performance payment bonds.

BASIS OF PAYMENT

Contractor shall request written approval for expenditure of any force account or contract allowance PRIOR TO performing the Work involved. List of Work to be performed and estimated cost shall be in the requesting correspondence.

Using the format provided by the City, the Contractors request for payment of all contract allowances shall be included in the Schedule of Values.

Payment will be made in accordance with the provision of General Condition Title 11. Payment will constitute full compensation for all work necessary to complete the item.

Work valued at \$5,000 or less, that must be performed by a licensed journeyman in order to comply with federal, state, or local codes, may be paid for after receipt of an itemized statement endorsed by the Contractor.

| <u>Item No.</u> | <u>Item</u> | <u>Quantity</u> | <u>Estimated Amount</u> |
|-----------------|--|-----------------|-------------------------|
| 700-70072 | Obtain Power from Xcel | A/A | \$ 50,000.00 |
| 700-70175 | Unknown Utilities | A/A | \$ 25,000.00 |
| 700-70210 | Lighting | A/A | \$100,000.00 |
| 700-70236 | Permits | F/A | \$ 25,000.00 |
| 700-70245 | Utility Tap Fee | F/A | \$ 25,000.00 |
| 700-70305 | Aesthetics | A/A | \$338,000.00 |
| 700-70380 | Erosion Control | A/A | \$ 50,000.00 |
| 700-70581 | Air Monitoring Specialist | A/A | \$ 15,000.00 |
| 700-70588 | RACS Excavation, Loading, and Transportation | A/A | \$ 50,000.00 |

A/A Obtain Power from Xcel shall be used to cover costs associated providing a new meter pedestal and service if needed for the irrigation system. Pending Xcel design and CCD maintenance agreement.

A/A Unknown Utilities shall be used to cover costs associated with utilities that were not discovered during design but are found during construction and need to be adjusted to facilitate construction.

A/A Lighting shall be used to cover costs associated with lighting construction by Xcel.

F/A Permits shall be used for any unexpected permits beyond those identified in the bid documents.

F/A Utility Taps shall be used for any tap fees that will be required to complete project work.

A/A Aesthetics shall be used to incorporate any Engineer requested bridge or other architectural or aesthetic enhancements.

Contract Control No. 2021-PROJMSTR-0000693

May 24, 2022

-2-

FORCE ACCOUNT AND ALLOWANCE ACCOUNT ITEMS

A/A Erosion Control shall be used for any unexpected erosion control measures required through coordination between projects or due to a change in conditions encountered during the course of the work.

A/A Air Monitoring Specialist and **A/A - RACS Excavation, Loading, and Transportation** shall be as defined in Revision to Section 250.

END OF SECTION

Contract Control No. 2021-PROJMSTR-0000693

May 24, 2022

APPENDICES

PROVIDED UNDER SEPARATE COVER

APPENDIX A - Materials Management Plan

APPENDIX B – Regulated Asbestos Contaminated Soil Standard Operation Procedure

APPENDIX C – Clarification on Guidance for Reuse of Soil on City Projects

APPENDIX D – Limited Environmental Screening, Larimer Street over Cherry Creek Bridge Replacement Project, Denver, Colorado

APPENDIX E - Geotechnical Report

Contract Control No. 2021-PROJMSTR-0000693

May 24, 2022

APPENDIX F

PAVEMENT DESIGN

Contract Control No. 2021-PROJMSTR-0000693

May 24, 2022

**MGPEC - VOLUME I –
PAVEMENT DESIGN STANDARDS
& CONSTRUCTION SPECIFICATIONS**

ITEM 20 ASPHALT PAVEMENT

| | | |
|-------------|---|-----------|
| 20.1 | DESCRIPTION | 3 |
| | A. Definition of Terms | 3 |
| | B. Contractor Process Control | 3 |
| 20.2 | MATERIALS | 4 |
| | A. Aggregate | 4 |
| | B. Reclaimed Asphalt Pavement (RAP) | 6 |
| | C. Quality Control (QC) Plan for RAP | 7 |
| | D. Reclaimed Asphalt Shingles (RAS) | 8 |
| | E. Mix Requirements | 11 |
| | F. Warm Mix Asphalt (Technologies) | 11 |
| | G. Mineral Filler | 11 |
| | H. Performance Graded Asphalt Binders | 12 |
| | I. Additives | 14 |
| 20.3 | DESIGN AND PRODUCTION REQUIREMENTS | 14 |
| | A. Superpave Mixture Design Method | 14 |
| 20.4 | MIXTURE DESIGN SUBMITTALS | 17 |
| | A. General Requirements | 17 |
| | B. Change in Source or Grade | 18 |
| | C. Mix Production Verification | 18 |
| | D. Pre-Paving Meeting | 19 |
| 20.5 | MANUFACTURE | 20 |
| | A. Preparation of Aggregates | 20 |
| | B. Mixing | 20 |
| | C. Hauling | 21 |
| 20.6 | TACK COAT | 21 |
| 20.7 | EQUIPMENT | 22 |
| | A. Mixing Plant | 22 |
| | B. Hauling Equipment | 22 |
| | C. Material Transfer Vehicle (MTV) | 22 |
| | D. Bituminous Pavers | 22 |
| 20.8 | PLACEMENT | 23 |
| | A. SMA Pre-Placement | 25 |
| | B. SMA Placement | 25 |
| | C. WMA Construction Requirements | 26 |

| | | |
|--------------|--|----|
| 20.9 | LONGITUDINAL JOINTS | 26 |
| 20.10 | TRANSVERSE JOINTS | 27 |
| 20.11 | SEGREGATION | 28 |
| 20.12 | COMPACTION | 28 |
| 20.13 | PRODUCTION TOLERANCES | 29 |
| A. | Top Lift Surface Tolerances | 29 |
| B. | Job Mix Formula Tolerances | 31 |
| 20.14 | CONFORMITY WITH PLANS AND SPECIFICATION | 32 |
| A. | General | 32 |
| B. | Pavement Thickness Deficiencies | 33 |
| C. | Use of Cores to Determine Acceptable Asphalt Thickness | 34 |
| D. | Verification of Thickness and Remedial Action | 34 |
| E. | Price Reduction on Thickness | 35 |
| F. | Average Core Thickness | 35 |
| G. | Individual Core Thickness | 35 |
| H. | Remove and Replace | 36 |
| I. | Cost Reduction Formula | 36 |
| 20.15 | TESTING AND INSPECTION | 38 |
| 20.16 | PAYMENT | 40 |

ITEM 20 ASPHALT PAVEMENTS

20.1 DESCRIPTION

This work shall consist of providing a bituminous mixture to be placed in one or more lifts over a prepared aggregate base or underlying subgrade as shown on the plans, or as directed by the **AGENCY**. The **CONTRACTOR** shall be responsible for Quality Control (QC) of the bituminous mixture; including the design, and control of the quality of the material incorporated into the project. The **AGENCY** will be responsible for Quality Assurance (QA); including testing, to assure the quality of the material incorporated into the project meet design parameters. The following specifications include general requirements applicable to all types of plant mixed asphaltic pavements. The work consists of one or more lifts of an asphalt mixture constructed on a prepared subgrade foundation. The work shall meet the requirements within the contract documents and in conformity with the lines, grades, thickness, and design cross sections as shown on the plans or established by the Agency's representative.

This specification is to provide a pavement with adequate thickness and quality to provide a serviceable life of at least 30 years. It is also the intent of this document to provide construction requirements in accordance with these specifications to a higher standard of practice. This item shall include all labor, equipment, and materials to manufacture, place, and compact asphaltic concrete for roadway pavement purposes.

A. Definition of Terms

Wherever the following abbreviations are used in the specifications or other contract documents, the intent and meaning will be interpreted as shown below:

| | |
|------------|--|
| AASHTO | American Association of State Highway & Transportation Officials |
| ASTM | American Society for Testing & Materials |
| HMA | Hot Mixed Asphalt |
| CP-## | Colorado Department of Transportation: Field Materials Manual (Colorado Testing Procedures) |
| CP-L ##### | Colorado Department of Transportation: Laboratory Manual of Test Procedures (Lab Testing Procedures) |
| RAP | Reclaimed Asphalt Pavement |
| RAS | Reclaimed Asphalt Shingles |
| HMA | Hot Mix Asphalt Pavement |
| SMA | Stone Matrix Asphalt |
| WMA | Warm Mix Asphalt Pavement |

B. Contractor Process Control

At least 30 days prior to placing any mixture on the project, the **CONTRACTOR** shall submit a mix design for acceptance.

The **CONTRACTOR** shall assume full responsibility for controlling all operations and processes such that the requirements of the Specifications are met at all

times. The **CONTRACTOR** shall perform any tests necessary at the plant and on site for process, control purposes and maintains a log of all process control testing. The Project Manager's representative will use both Quality Assurance (QA) and Quality Control (QC) test results when determining acceptability.

Prior to use on the project the **CONTRACTOR** shall submit a quality control plan that addresses production, sampling, testing, qualifications of testing personnel, timing, and methods for making adjustments to assure compliance with the specifications. The **CONTRACTOR** will provide a process or schedule for making corrections for material that was placed but does not meet specifications as well as obtain a follow up sample immediately after corrective actions are taken to assess the adequacy of the corrections. In the event the follow-up process control sample also fails to meet Specification requirements, the **CONTRACTOR** shall cease production of the asphalt mixture until the problem is adequately resolved to the satisfaction of the QC Manager and Project Manager.

20.2 MATERIALS

Asphalt mixtures will consist of various aggregates, filler, hydrated lime, and asphalt binder. If stated in the contract document, Asphalt mixtures may contain Reclaimed Asphalt Pavement (RAP), Reclaimed Asphalt Shingles (RAS), as well as a variety of binders and additives.

A. Aggregate

Asphalt material aggregate shall be of uniform quality, composed of clean, hard, durable particles of crushed stone, crushed gravel, or crushed slag. The material shall not contain clay balls, vegetable matter, rounded aggregate, or other deleterious substances, and shall meet the following requirements:

**TABLE 20.2A-1
Aggregate Properties**

| Aggregate Test Property | Coarse: Retained on #4 | Fine: Passing the #4 |
|---|--|-------------------------|
| Fine Aggregate Angularity, CP-L 5113 Method A or AASHTO T 304 (Does not apply to RAP or RAS aggregates) | | 45% Min |
| Two Fractured Faces, ASTM D 5821 SG Mixtures Top and Middle Lifts Bottom Lifts SMA Mixtures | 90% Min. 80% Min. 70% Min. 100% required | |
| LA Abrasion, AASHTO T 96 | 45% Max. | |
| Flat and Elongated (Ratio 5:1) %, AASHTO M 283 | 10% Max. | |
| Sand Equivalent. AASHTO-T 176 | | 45% Min. |
| Micro Deval AASHTO T 327 | 18% Max for individual materials 20% Max. for combined sample | |

TABLE 20.2A-2
Dense Graded Asphalt Material Gradation Range
(Percent by Weight Passing Square Mesh Sieves, AASHTO T 11 & T 27)

| Mixture Grading | ST (3/8" Nominal) | SX (1/2" nominal) | S (3/4" nominal) | G (1" nominal) |
|------------------|---------------------------------------|--|----------------------------|----------------------------|
| Traffic Loading, | Repair Segregation Bike path Sidewalk | Low to Medium 0 to 300,000 Top Lift only | Medium To High >300,000 | All Loading Lower lifts |
| Sieve Size | Control Points | Control Points | Control Points | Control Points |
| 1 1/2" | | | | 100 |
| 1" | | | 100 | 90-100 |
| 3/4" | | 100 | 90-100 | @ |
| 1/2" | 100 | 90-100 | @ | @ |
| 3/8" | 90-100 | @ | @ | @ |
| #4 | @ | @ | @ | @ |
| #8 | 28-58 | 28-58 | 23-49 | 19-45 |
| #16 | @ | @ | @ | @ |
| #30 | @ | @ | @ | @ |
| #50 | @ | @ | @ | @ |
| #200** | 2.0-10.0 | 2.0-8.0 | 2.0-7.0 | 1.0-7.0 |

**These limits shall include the required 1% of lime by weight.

@ These sieve sizes used to determine the final Job Mix Formula (JMF) in accordance with **Section 20.2B**.

TABLE 20.2A-3
SMA Aggregate Gradation Range Properties
(Percent by Weight Passing Square Mesh Sieves, AASHTO T 11 & T 27)

| Sieve Size | Stone Mastic Grading Designation for Top Layer for Traffic Loading in High Range greater than 3.0 Million ESALs (Percent by Weight Passing Square Mesh Sieves) | |
|----------------|---|--------------|
| | 1/2" Nominal | 3/4" Nominal |
| 25 mm (1") | | 100 |
| 19.0 mm (3/4") | 100 | 90-100 |
| 12.5 mm (1/2") | 90-100 | 50-88 |
| 9.5 mm (3/8") | 50-80 | 25-60 |
| 4.75 mm (#4) | 20-35 | 20-28 |
| 2.36mm (#8) | 16-24 | 16-24 |
| 1.18mm (#16) | @ | @ |
| 600 µm (#30) | 12-18 | 12-18 |
| 300 µm (#50) | @ | @ |
| 150 µm (#100) | @ | @ |
| 75 µm (#200) | 8-11 | 8-11 |

@ These sieve sizes used only to determine the final Job Mix Formula (JMF) in accordance with **Section 20.2B**.

B. Reclaimed Asphalt Pavement (RAP)

Material may be used only where specifically allowed and shall be of uniform quality and gradation with a maximum size no greater than the nominal aggregate size of the mix. Grading G shall not contain more than 35% RAP. All other gradations may contain up to 25% or as specified in the construction documents. The allowable percentage of RAP or recycled materials allowed will be listed in the construction documents and may vary by pavement layer. When RAP content is greater than 15%, the in-place properties of the binder will need to meet the required Performance-Graded Binder as tested using Dynamic Shear testing procedure TP 5. TP 5 shall be performed during the initial mix design and periodically throughout the paving season, at a suggested rate of one test per every 20,000 tons per mix design.

RAP if allowed in the Asphalt mixture shall be of uniform quality and gradation with a maximum size particle no greater than the maximum size allowed in the mixture. HMA mixtures containing RAP shall meet the same gradation requirements as a virgin HMA mix. The **AGENCY** may determine the allowable percentage of RAP to be utilized in the top lift, The **AGENCY** may allow a maximum of 25% RAP in mixture grading S may be allowed in layers below the top lift or a maximum of 35% RAP in mixture grading G. RAP or RAS are not allowed in Stone Mastic Asphalt Mixtures.

The reclaimed asphalt pavement shall meet all the requirements for Asphalt Pavements, as contained herein. The **CONTRACTOR** shall have an approved mix design for HMA with RAP prior to placement and shall include the asphaltic binder and virgin aggregate that are to be used to meet the requirements contained herein.

The **CONTRACTOR** shall maintain separate stockpiles for each type of RAP material. All processed material shall be free of foreign materials and segregation shall be minimized. Any RAP material that cannot be readily broken down in the mixing process, and/or affects the paving operation, shall be processed prior to mixing with the virgin material.

Fine Aggregate Angularity requirements shall not apply to RAP aggregate. RAP shall not contain clay balls, vegetable matter, or other deleterious substances.

Verification testing for asphalt content and gradation will be performed on RAP at the frequencies listed on **Table 20.2B-1**, below. The Asphalt Supplier shall provide testing results on RAP, and RAP/RAS mixtures daily. The Asphalt Supplier shall provide results of tests for properties listed in this specification.

When RAP is allowed for use in Asphalt mixtures, the following additional conditions shall apply:

The aggregate obtained from the processed RAP shall be 100% passing the 1" sieve. The aggregate and binder obtained from the processed RAP shall be uniform in all the measured parameters to the mix design submitted in accordance with the following:

**Table 20.2B-1
RAP Aggregate Uniformity Tolerances**

| Element | Uniformity* |
|----------------|-------------|
| Binder Content | 0.5 |
| % Passing 3/4" | 4.0 |
| % Passing 1/2" | 4.0 |
| % Passing 3/8" | 4.0 |
| % Passing #4 | 4.0 |
| % Passing #8 | 4.0 |
| % Passing #30 | 3.0 |
| % Passing #200 | 1.5 |

*Uniformity is the Maximum allowable Standard Deviation of test results of processed RAP.

C. Quality Control (QC) Plan for RAP

A QC plan details how the RAP will be processed and controlled shall be developed and followed by the Asphalt Producer/ Contractor and shall address the following:

A schematic diagram and narrative that explains their RAP processing techniques required for crushing, screening, rejecting, and stockpile operation for normal plant operation,

The control of RAP Asphalt Binder Content with a minimum testing frequency of 1/1,000 tons of processed RAP material (minimum 3 tests) for most recent production of the mix,

The control of RAP Gradation (AASHTO T-30) with a minimum testing frequency of 1/1,000 tons of processed RAP material (minimum 3 tests) for most recent production of the mix,

Process control charts shall be maintained for binder content and each screen when RAP material is added to the stockpile. Separate control charts for each RAP stockpile shall be maintained. These charts shall be displayed and shall be provided upon request.

D. Reclaimed Asphalt Shingles (RAS)

When allowed by the construction documents RAS may be allowed in Asphalt Mixtures up to a maximum of 5 percent of the total weight of the mix for all lifts other than the top lift, provided all specifications for HMA are met. **Mixtures with more than 3 percent RAS shall not be used in the top lift of any asphalt pavement.** RAS may be obtained from either pre-consumer or post-consumer asphalt shingles. Post-consumer (tear off) asphalt shingles shall be in accordance with AASHTO MP 15 and prepared by approved asbestos management facilities shall operate in accordance with this plan and maintain all necessary state issued operating facility permits as required. A copy of this letter shall be submitted to the **AGENCY**. Deleterious material present in post-consumer asphalt shingles shall be limited to the percentages stated in AASHTO MP 15. Pre-consumer and post-consumer asphalt shingles shall not be blended for use in HMA mixtures and shall be stockpiled separately from other materials.

The in-place properties of the binder will meet the required for the specified Performance-Graded Binder as stated in **Table 20.2H-1**

RAS material shall not contain clay balls or vegetative matter. Deleterious substances such as metals, glass, rubber, soil, brick, tar-paper, wood, or plastic shall not exceed 1.5% by weight as verified by test results run for every 5,000 tons of mix or fraction thereof. The **CONTRACTOR** shall provide test results verifying no asbestos has been detected in the RAS and certified as meeting EPA NESHAP requirements.

RAS will be ground to meet AASHTO PP 53 requirements. The RAS shall be sampled and tested for gradation at a frequency of every 5,000 tons or at least once per day during production.

RAS samples collected and analyzed, for the purpose of identifying properties of RAS as defined in this specification, shall be representative of the RAS that will be used in the HMA production.

The moisture content of the RAS shall at no time exceed 15% by mass.

The **CONTRACTOR** shall have an approved mix design for the amount of RAS to be used. The AC content of the RAS utilized in the **CONTRACTOR** RAS mix design shall be the average AC content determined in accordance with 1B below. The AC content of the RAS utilized in the mix design shall be determined in accordance with AASHTO T164, Method A or B. The **CONTRACTOR** may use both RAS and RAP in the mix design. The **CONTRACTOR** shall determine the total binder replacement by the binder in the RAS and RAP and the percentage of virgin binder in the HMA pursuant to AASHTO PP 53 methods and the following equation:

$$\text{Total Binder Replacement} = ((A \times B) + (C \times D)) \times 100/E$$

Where: A= RAP% binder Content*

B= RAP% in Mix*

C=RAS % Binder Content*

D= RAS % in Mix*

E = Total Effective Binder Content*

*In decimal format

The Total Binder Replacement by the binder in the RAS and/or RAP shall not exceed 30% of the effective binder content of either the mix design or the production mix.

The **CONTRACTOR** may uniformly blend sand or fine aggregate with RAS in the stockpiles if needed to keep the processed material workable. The sand or fine aggregate added must be considered in the final gradation of the HMA design.

HMA with RAS and/or RAP shall be tested in accordance with the above section. Project verification testing for asphalt content and gradation will be performed at the frequency noted in the above section.

The **CONTRACTOR** shall have an approved Quality Control (QC) Plan that details how the RAS will be processed and controlled. The QC plan shall address the following:

RAS Processing Techniques:

This requires a schematic diagram and narrative that explains the processing (crushing, screening, and rejecting) and stockpile operation for the project.

Determination and Control of RAS Asphalt Binder Content shall be determined by (AASHTO T 164, Method A or B) at a frequency of 1/1,000 tons of processed RAS material.

Control of RAS Gradation (AASHTO T 30): Testing of RAS shall be at a frequency of 1/1,000 tons of processed RAS material.

Process Control Charts shall be maintained for binder content and gradation, during addition of any RAS material to the stockpile. The **CONTRACTOR** shall maintain separate control charts for each RAS stockpile. The control charts shall be displayed and shall be made available to the Agency upon request.

Asbestos content of RAS:

Test RAS sample for asbestos at a frequency of 1/1,000 tons of processed RAS material.

Moisture content of RAS:

Testing at a frequency of 1/day

Deleterious Material Frequency of 1/100 tons of RAS material utilized.

The processed RAS shall meet the following gradation requirements:

**Table 20.2D-1
Shingle Aggregate Gradation**

| Sieve Size | Percent Passing by Mass |
|------------|-------------------------|
| 3/8 in | 100 |
| No.4 | 95 |
| No.8 | 85 |
| No. 16 | 70 |
| No. 30 | 50 |
| No. 50 | 45 |
| No. 100 | 35 |
| No. 200 | 25 |

The aggregate and binder obtained from the processed RAS shall be uniform in all the measured parameters to during production, the asphalt mixture shall be in accordance with the approved mix design and in accordance with the following:

**Table 20.2D-2
Uniformity* Tolerances**

| Element | Uniformity* |
|-------------------------------------|-------------|
| Binder Content | 0.5 |
| % Passing 19 mm ($\frac{3}{4}$ " | 4.0 |
| % Passing 12.5 mm ($\frac{1}{2}$ " | 4.0 |
| % Passing 9.5 mm ($\frac{3}{8}$ " | 4.0 |
| % Passing 4.75 mm (#4) | 4.0 |
| % Passing 2.36 mm (#8) | 4.0 |
| % Passing 600 μ m (#30) | 3.0 |
| % Passing 75 μ m (#200) | 1.5 |

*Uniformity is the Maximum allowable Standard Deviation of test results of processed RAS.

The **CONTRACTOR** shall supply a Performance Graded Binder which meets the AASHTO MP-1 specifications for one temperature grade lower for both the high and low end than that specified in the contract when RAS is included in the mix. For example, if the Contract originally specified a PG 64-22, the **CONTRACTOR** shall supply a binder meeting the AASHTO MP-1 specifications for a PG 58-28, subject to **AGENCY** approval.

The **CONTRACTOR** shall supply the **AGENCY** with total binder grading tests from production samples collected when utilizing RAP and RAS.

Warm Mix Asphalt Provisions

Warm Mix Asphalt (WMA) is the generic term used to describe the reduction in production, paving and compaction temperatures achieved through the application of one of several WMA technologies. The producer shall submit a mix design for Warm Mix Asphalt production, or submit a statement that details production and testing items that require attention if the design is performed by standard HMA practice. All provisions for the production and placement of conventional hot mix asphalt (HMA) mixtures as stipulated in above sections except as noted below.

E. Mix Requirements:

One or a combination of several technologies involving hot mix asphalt plant foaming processes and equipment, mineral additives, or chemicals that allows the reduction of mix production temperatures by as much as 100°F. A WMA mixture design shall identify the technology to be used. The producer shall comply with the manufacturer's recommendations for incorporating additives and WMA technologies into the mix. Comply with the manufacturer's recommendations regarding receiving, storage, and delivery of additives. Maintain supplier recommendations on file at the asphalt mixing plant, make available for reference while producing WMA, and be available to the **AGENCY** upon request.

F. Warm Mix Asphalt (Technologies):

WMA designs shall be developed using the specified additives or method. Each WMA design shall specify the production temperatures recommended by the WMA additive manufacturer to be used in production of Warm Mix Asphalt.

Chemical Modifiers to be considered are:

- The addition of a synthetic zeolite called Aspha-Min® during mixing at the plant to create a foaming effect in the binder.
- A two-component binder system called WAM-Foam® (Warm Asphalt Mix Foam), which introduces a soft binder and hard foamed binder at different stages during plant production.
- The use of organic additives such as Sasobit®, a Fischer-Tropsch paraffin wax and Asphaltan B®, a low molecular weight esterified wax.
- Plant production with an asphalt emulsion product called Evotherm™, which uses a chemical additive technology and a "dispersed asphalt technology" delivery system.
- The addition of a synthetic zeolite called Advera® WMA during mixing at the plant to create a foaming effect in the binder.

Foamed WMA technologies must be submitted to and approved by the **AGENCY** for use on a specific project or asphalt layer.

G. Mineral Filler

Mineral filler for use with Stone Matrix Asphalt (SMA) pavement may consist of limestone dust or any other material filler that will meet the requirements of this

subsection and have a maximum Plasticity Index (AASHTO T 90) of less than or equal to 4.0 %.

The **CONTRACTOR** shall submit hydrometer analysis (AASHTO T 88) for the gradation of mineral filler used in the SMA mixture.

H. Performance Graded Asphalt Binders

The **CONTRACTOR** shall provide to the **AGENCY** acceptable 'Certifications of Compliance' of each applicable asphalt binder grade from the supplier. Should testing or certificate show nonconformance with the specifications, the asphalt binder may be rejected. When production begins, the **CONTRACTOR** shall, upon request, provide to the **AGENCY** a one quart can of each specified asphalt binder for analysis. Additionally, the **CONTRACTOR** shall provide the refinery test results that pertain to the asphalt binders used during production.

Asphalt binder shall meet the requirements of the Superpave Performance-Graded Binders (PG) as presented in **Table 20.2H-1**.

**TABLE 20.2H-1
Properties of Performance Graded Binders**

| Usage for each Binder Grade | PG 58-28 | PG 64-22 | PG 76-28 |
|--|--------------------------|--------------------------|---------------------------|
| Traffic Loading, Total 18 kip ESALs Over Design Life (20 to 30 Years) | Low Volume (0-300,000) | >300,000 to <3.0 Million | >3.0 Million |
| Superpave Compactor Design gyrations Recommended Usage | N _{design} = 50 | N _{design} = 75 | N _{design} = 100 |
| Property of Binder Grade | PG 58-28 | PG 64-22 | PG 76-28 |
| Flash Point Temperature, °C, AASHTO T 48 | 230 Min. | 230 Min. | 230 Min. |
| Viscosity at 135 °C, Pas, ASTM D 4402 | 3 Max. | 3 Max. | 3 Max. |
| Dynamic Shear, Temperature °C, where C*/Sin δ @ 10 rad/sec. ≥ 1.00 Kpa, AASHTO TP 5 | 58 ° C | 64 ° C | 76 ° C |
| Rolling Thin Film Oven Residue Properties, AASHTO T 240 | | | |
| Mass Loss, %, AASHTO T 240 | 1.00 Max. | 1.00 Max. | 1.00 Max. |
| Dynamic Shear, Temperature °C, where G*/Sin δ @ 10 rad/sec. ≥ 2.20 Kpa, AASHTO TP 5 | 58 ° C | 64 ° C | 76 ° C |
| Elastic Recovery ₁ , 25°C, % Min.* | N/A | N/A | 50 Min. |
| Pressure Aging Vessel Residue Properties, Aging Temperature 100 °C AASHTO PP1 | | | |
| Dynamic Shear, Temperature °C, where G*/Sin δ @ 10 rad/sec. ≤ 5,000 Kpa, AASHTO TP 5 | 19 ° C | 25 ° C | 28 ° C |
| Creep Stiffness, @ 60 sec. Test Temperature in °C, AASHTO TP 1 | -18 ° C | -12 ° C | -18 ° C |
| S, Mpa, AASHTO TP 1 | 300 Max. | 300 Max. | 300 Max. |
| m-value, AASHTO TP 1 | 0.300 Min. | 0.300 Min. | 0.300 Min. |
| **Direct Tension Temperature in °C, @ 1.0 mm/min., Where Failure Strain >1.0%, AASHTO TP 3 | -18 ° C | -12 ° C | -18 ° C |

*Elastic Recovery by Task Force 31, Appendix B Method

** Direct tension measurements are required when needed to show conformance to AASHTO MP.1

*** Agency is to determine PG Binder

I. Additives

Hydrated Lime shall be added at the rate of 1% by dry weight of the aggregate and shall be included in the amount of material passing the No. 200 sieve. Hydrated lime for aggregate pretreatment shall conform to the requirements of ASTM C 207, Type N. In addition, the residue retained on a No. 200-mesh sieve shall not exceed 10% when determined in accordance with ASTM C 110. Drying of the test residue in an atmosphere free from carbon dioxide will not be required.

Use of any other additives used in the production of asphalt mixtures shall be approved by the **AGENCY**.

20.3 DESIGN AND PRODUCTION REQUIREMENTS

There shall be no substitutions of materials allowed during production. All substitutions will require checkpoint verification if the checkpoint differs from the Job Mix Formula (JMF) a new mix design will be required. Upon request of the **AGENCY**, the binder grade may be changed by one available binder grade level without requiring a new mix design.

The **AGENCY** shall indicate on "**Mixture Design Requirements for Hot Mix Asphalt Pavements**" form provided in the appendix project specification documents the criteria concerning mix design method, traffic level, binder type, mixture grading, and maximum amount of RAP allowed. This information form is provided on MGPEC Form "**Mixture Design Requirements for Hot Mix Asphalt Pavements**", or other Contract bidding documents.

Grading SG (1-inch nominal aggregate) shall only be designed using the 150 mm Superpave molds. Hveem Stability and Lottman test are not required for Grading G mixtures. Grading ST, SX, and S shall be designed using 100 mm Superpave molds.

A. Superpave Mixture Design Method

A JMF design shall be submitted for each mixture required, at least seven (7) days prior to construction. The JMF design shall be determined using AASHTO T-312 for the Superpave Method of Mixture Design.

Mixture design and field control testing shall meet the following of **Table 20.3A-1** for Dense Graded Asphalt Mixes.

Mixture design and field control testing of SMA shall meet the following requirements of **Table 20.3A-2** for Stone Matrix Asphalt.

TABLE 20.3A-1
Superpave Mixture Properties for Dense Graded Asphalt Mixtures

| Property or Test | Traffic Level | | |
|---|---|--------------------------------------|----------------------|
| | Low (0-300,000) | Medium >300,000 to 3.0 Million | High >3.0 Million |
| Traffic Loading, Total 18 kip ESALs Over Design Life (20 to 30 Years) | Low (0-300,000) | Medium >300,000 to 3.0 Million | High >3.0 Million |
| Design gyrations, N _{design} (Air Void: 3.5% to 4.5%) (See Note 1,2) | 50 | 75 | 100 |
| Air Voids in Total Mix (VTM) AASHTO T-312 (See Note 1) | 3.5-4.5 | 3.5-4.5 | 3.5-4.5 |
| Hveem Stability AASHTO T-246 (Grading S & SX only) (See Note 3) | N/A | 28 Min. | 30 Min. |
| Voids Filled with Asphalt, MS-2 | 70-80 | 65-78 | 65-75 |
| Lottman, Tensile Strength Ratio, % Retained, AASHTO T-283, Method B | 80 Min. | 80 Min. | 80 Min. |
| AASHTO T-283 Dry Tensile Strength, psi | 30 Min. | 30 Min. | 30 Min. |
| Voids in Mineral Aggregates (VMA) %. AASHTO PP 19 (See notes 2,3,4) | A minimum VMA criterion applies to the mix design only (Table 20.2-3). The minimum VMA criteria shall be linearly interpolated based on actual air voids. See 20.12-1 for production tolerances | | |

Note 1: Target Optimum asphalt binder content of mix: Choose target % as close to 4.0 air voids as possible (3.5% to 4.5% air voids).

VTM is also referred to as Pax in CPL 5115, and %Gmmx in AASHTO T 312

Note2: Maximum Theoretical Specific Gravity of mix is to be determined by AASHTO T 209.

Note 3: Refer to **Section 20.2B** for production tolerances.

Note 4: VMA shall be based on tests of the Bulk Specific Gravity of the Compacted Mix (AASHTO T 166) and Aggregate (AASHTO T 84 & T 85), and calculated according to AASHTO PP 19. All mixes shall meet the minimum VMA specified in **Table 20.3A-3**.

**Table 20.3A-2
Superpave Mixture Properties for Open Graded SMA**

| Property | Test Method | Value for SMA |
|--|---------------------------|-------------------------|
| Lab compaction (Revolutions) N_{Design} | AASHTO T-312 | 100 |
| Air Voids, percent at: N_{Design} (See Note 1) | AASHTO T-312 | 3.0 – 4.0 |
| Hveem Stability | AASHTO T-245 75 Blows | 1400 psi Min. |
| Accelerated Moisture Susceptibility, tensile strength Ratio, (Lottman) | AASHTO T 283, Method B | 80 Min. |
| Dry Split Tensile Strength, psi | ASHTO T 283, Method B | 30 Min. |
| Grade of Asphalt Binder | n/a | PG 76-28 |
| Voids in the Mineral Aggregate (VMA) %, minimum | AASHTO PP 19 | 17 (See Note 5) |
| Draindown at Production Temperature | AASHTO T305 | 0.3 maximum |
| $\% VCA_{Mix}^1$ (See Note 2) | AASHTO PP41-02 | Less than VCA_{DRC}^2 |

Note1: Copies of AASHTO PP 41-02 and MP 8-02 (designing SMA mixes) can be obtained from the CDOT Region Materials or the Agency

Note 2: Select target Job Mix Optimum Binder Content for SMA grading at 3.0% to 4.0% air voids

Note 3: Voids in the Coarse Aggregate
Note 4: Dry-rodged condition

Note 5: The formula for VMA can be developed as follows based on the weight volume relationship. It is recommended that the bulk specific gravity of aggregate be used for calculating VMA.

$$VMA = \{ \{ VT - V_{Agg}(\text{bulk}) \} / VT \} * 100$$

**TABLE 20.3A-3
Minimum Voids in Mineral Aggregate (VMA) for
Dense Graded & Open Graded (SMA), %**

| Nominal Maximum* Particle Size | Air Voids ++ | | |
|-----------------------------------|--------------|------|------|
| | 3.5% | 4.0% | 4.5% |
| 1" | 12.2 | 12.7 | 13.2 |
| ¾" | 13.2 | 13.7 | 14.2 |
| ½" | 14.2 | 14.7 | 15.2 |
| SMA | 17.0 | 17.0 | 17.0 |

*Nominal Maximum Particle Size is defined as one sieve size larger than the first sieve to retain more than 10%, but shall not exceed the 100% passing size. The Nominal Maximum Particle Size can vary during mix production even when the 100% passing size is constant.

++

Minimum VMA criteria apply to the mix design only. The minimum VMA criteria shall be linearly interpolated based on actual air voids. See **Section 20.2B** for tolerances.

20.4 MIXTURE DESIGN SUBMITTALS

A. General Requirements:

The **CONTRACTOR** shall submit all mix designs, Certificates of Compliance, and laboratory data to the **AGENCY** for approval at least 7 calendar days before construction is to begin. The mix design (Proposed Design Job Mix) must be approved by the **AGENCY** prior to the start of construction.

Designs shall be developed and performed in a materials laboratory that meets the requirements set forth by AASHTO Materials Reference Laboratory (AMRL) for all required testing procedures and be under the direct supervision of and be stamped and signed by a Professional Engineer licensed in the State of Colorado and practicing in this field. In addition, the **CONTRACTOR** shall submit, as part of the mixture design, laboratory data documents to verify the following:

- Gradation, specific gravity, source and description of individual aggregates and the final blend.
- Aggregate physical properties.
- Source and Grade of the Performance Graded Binder
- Proposed Design Job Mix: aggregate and additive blending, final gradation shown on 0.45 power graph, optimum asphalt content.
- Mixing and compaction temperatures used.
- Mixture properties shall be determined with a minimum of four asphalt contents and interpolated at optimum and graphs showing mixture properties versus asphalt content.

CONTRACTOR shall obtain approval of all mix designs for any Asphaltic Pavement Material (HMA, WMA, or SMA) by **AGENCY** prior to placement. The Project Manager reserves the right to verify the asphalt supplier's mix design for each Asphaltic Material grading utilizing materials actually produced and stockpiled. The asphalt supplier shall provide, at no cost, a sufficient quantity of

each aggregate, mineral filler, RAP, and additive for the required laboratory tests, as well as all Certificates of Conformance/ Compliance at any time on any material used. The Asphalt Supplier shall provide copies of quality control testing results during the production of asphaltic mixtures used within one (1)-business day from the sampling date.

B. Change in Source or Grade:

Should a change in the source of any material used in the production of asphaltic pavement material (Aggregate, Mineral filler, Lime, or Performance Graded Asphalt Binder) occur, a one point verification test (at optimum asphalt content) of the mix must be performed to verify that the applicable criteria shown on **Table 20.3A-1** (Dense Graded Asphalt Mix), **Table 20.3A-2** (SMA), and **Table 20.3A-3** (VMA), is still met. If this testing shows noncompliance, the **CONTRACTOR** shall establish a new Job Mix Design and obtain approval by the **AGENCY** before the new Asphaltic Material is used.

C. Mix Production Verification:

Production verification shall occur prior to the start of the project. Technicians that have current LabCAT Level C certification shall verify the volumetric properties of the mix. Certified technicians shall maintain current Certification to verify the volumetric properties of the mix. If the mix was produced for another project within the last 90 days, data from that project can be submitted for verification. Volumetric properties for mix verification testing shall be within the following tolerances compared to the Proposed Design Job Mix. The mix verification test reports shall be submitted to the **AGENCY** prior to mix placement.

**TABLE 20.4C-1
Mix Design Verification Tolerances**

| | |
|------------------------|--------------------|
| Air Voids | +/- 1.2% |
| VMA | +/- 1.2% |
| Asphalt Binder Content | +/-0.3% |
| Stability | Applicable minimum |

The tolerances in this table are for mix design verification only. See **Section 20.2B** for production tolerances.

Project Verification Testing for asphalt content and gradation will be performed at the frequencies listed in **Table 20.15-1**

**Table 20.4C-2
Minimum Quality Control Sampling and Testing for Bituminous Mixtures**

| | AASHTO | ASTM | Minimum Frequency of Tests |
|--|-------------------------|---------------------------|--|
| Sampling* | T 168 | D 979 D 3665 | One per 1,000 tons or fraction thereof (not less than one test per day) |
| Hveem properties | T 245 T 247 T 166 | D 1559 D 1561 | One per 1,000 tons or fraction thereof (not less than one test per day) |
| In-place density | | D 1188 D 2950 | One per 250 linear lane feet per layer |
| Asphalt content | T 164 T 269 TP 53 | D 2172 D 3203 PS 90 | One per 1,000 tons or fraction thereof (not less than one test per day) |
| Maximum Specific Gravity of HBP | T 209 | D 2041 | One per 1,000 tons or fraction thereof (not less than one test per day) |
| Air voids and VMA | T 269 | D 3203 | One per 1,000 tons or fraction thereof (not less than one test per day) |
| Thickness | | D 3549 | One for each 250 linear lane feet |
| Aggregate Gradation | T 27 | C 136 | One per 1,000 tons or fraction thereof (not less than one test per day) |
| Binder Performance-Graded, Dynamic Shear | TP 5 | | One test per every 15,000 tons or fraction thereof |

*Contractor shall provide plant split samples to the appropriate testing Agency.

D. Pre-paving Meeting:

The **AGENCY** may require a pre-paving meeting of all parties that are directly involved in supply, haul, laydown, inspection, quality control, and quality assurance of asphalt pavement are required. Traffic control, haul, direction, sequence of paving and construction (joint) plan will be reviewed and discussed at the pre-paving meeting, see **Section 20.9** and **Section 20.10** for joint requirements. MGPEC Asphalt Design Requirements Form provided in this document or online at:

http://mgpec.org/assets/Form_20_-_202143349.pdf.

The Asphalt Index of this specification is an example of a pre-paving meeting agenda. Areas of responsibility and contact names and numbers **should** be shared.

A minimum of seven (7) days prior to the proposed use of any Asphalt pavement on the project, a pre-paving conference may be conducted at the Agency's discretion. Two (2) weeks prior to the meeting, the **CONTRACTOR** shall submit, a mix design for all proposed asphaltic materials specified in the projects specification and will meet the appropriate materials specification requirements.

20.5 MANUFACTURE

A. Preparation of Aggregates:

Heating and drying of the aggregates shall be accomplished without damaging the aggregate. Hydrated lime shall be added to achieve complete and uniform coating of the aggregate, in accordance with one of the following methods:

- 1) Lime Slurry Added to Aggregate: The hydrated lime shall be added to the aggregate in the form of slurry and then thoroughly mixed in an approved pugmill. The slurry shall contain a minimum of 70 percent water by weight.
- 2) Hydrated Lime Added to Wet Aggregate: The hydrated lime shall be added to wet aggregate (a minimum of three percent above saturated surface dry) and then thoroughly mixed in an approved pugmill. The lime-aggregate mixture may be fed directly into the hot plant after mixing or it may be stockpiled for not more than 90 days before introduction into the plant for mixing with the asphalt binder. The hydrated lime may be added to different sized aggregates and stockpiled by adding 75 percent of the lime to the aggregate passing the No. 4 sieve and 25 percent to the aggregate retained on the No. 4 sieve.

A minimum of 1 percent hydrated lime by weight of the combined aggregate shall be added to the aggregate for all Dense Graded and Open Graded Stone Matrix Asphalt mixtures.

B. Mixing:

The dried aggregates and asphalt binder shall be combined in the mixer in the quantities required to meet the design job mix. The materials shall be mixed until the aggregate is completely and uniformly coated, and the asphalt binder is uniformly distributed throughout the aggregate. Baghouse fines may be fed back to the mixing plant in a uniform and continuous manner to maintain uniformity in the mixture.

The minimum temperature of HMA or SMA mixtures when discharged from the mixer shall be according to refinery recommendations or as shown in the following table:

**TABLE 20.5B-1
Mixture Discharge Temperatures**

| HMA and SMA Asphalt Grade | Minimum Discharge Temperature | Maximum Discharge Temperature |
|---------------------------|-------------------------------|-------------------------------|
| PG 58-28 | 275° F | 310° F |
| PG 64-22 | 290° F | 325° F |
| PG 76-28* | 318° F | 326° F |
| WMA | 212° F | 280° F |

*Contractor or Binder supplier must supply production temperature as required by their product

HMA mix shall be produced at the lowest temperature within the specified temperature range that produces a workable mix and provides for uniform coating of aggregates (95 percent minimum in accordance with AASHTO T 195), and that allows the required compaction to be achieved.

Asphaltic mixtures may be stored provided that any and all characteristics of the mixture are not altered by storage. Unsuitable mixture shall be removed and disposed of at the **Contractor 's** expense.

When placing hot mix asphalt over bridge decks covered by waterproofing membrane, the minimum temperature of the mixture, when rolling operations begin, shall be 250 ° F. The job mix temperature may be increased up to 30 ° F to obtain this temperature.

Mineral filler for SMA shall be stored in a separate silo and added automatically in the correct proportion.

The SMA mineral filler shall be added at the same point the asphalt binder

C. Hauling:

Each truck shall be completely covered (non-porous tarps preferred) to completely protect the mix during transport at all times. The **AGENCY** can reject any mix which was transported through adverse weather or shows an excess or deficiency of asphalt cement, damage due to burning or overheating, when it arrives on the jobsite uncovered.

20.6 TACK COAT

The emulsified asphalt, for Tack Coat emulsion shall meet the specification for emulsified asphalt, consisting of CSS-1h or SS-1h and conform to AASHTO M208 or M140, respectively.

Prior to placement of HMA, a tack coat shall be applied to all existing concrete and asphalt surfaces. The material shall be in accordance with **20.2**. The emulsified asphalt shall be applied per **Table 20.6-1**. The surface prior to receiving the tack coat shall be dry and clean. All dust, debris, and foreign matter shall be removed. Tack coat shall be applied uniformly by distributor. Prior to paving, all water shall have evaporated from the tack coat, the time required between the application of the tack coat and the application of the asphalt may require 20 minutes or greater to achieve a set. Areas where the tack becomes contaminated during construction shall be cleaned and tack coat shall be reapplied and allowed to cure before paving resumes.

**TABLE 20.6-1
Tack Coat Application Rates**

| Pavement Condition | Application Rate (gal/yd ²) | | |
|----------------------|---|-------------|---------------|
| | Residual | Undiluted | Diluted (1:1) |
| New HMA | 0.03 - 0.04 | 0.05 – 0.07 | 0.10 – 0.13 |
| Oxidized HMA | 0.04 – 0.06 | 0.07 – 0.10 | 0.13 – 0.20 |
| Milled Surface (HMA) | 0.06 – 0.08 | 0.10 – 0.13 | 0.20 – 0.27 |
| Milled Surface (PCC) | 0.06 – 0.08 | 0.10 – 0.13 | 0.20 – 0.27 |

| | | | |
|--------------------------|-------------|-------------|-------------|
| Portland Cement Concrete | 0.04 – 0.06 | 0.07 – 0.10 | 0.13 – 0.20 |
|--------------------------|-------------|-------------|-------------|

Per NCHRP Report 712

20.7 EQUIPMENT

A. Mixing Plant

The mixing plant shall be capable of producing a uniform material, have adequate capacity, and be maintained in good mechanical condition. Defective parts shall be replaced or repaired immediately if they adversely affect the proper functioning of the plant or plant units, or adversely affect the quality of the HMA.

The mixing plant shall meet all air quality requirements in the "Colorado Air Quality Control Act," Title 25, Article 7, CRS and any other applicable regulations promulgated there under for dust, smoke, or other contaminants and shall be controlled at the plant and project site. As well as all acceptable safety equipment required by OSHA to accommodate sampling and testing.

B. Hauling Equipment:

Trucks used for hauling HMA material shall have tight, clean, smooth beds or functional and maintained conveyor belt bottom that is thinly coated with a minimum amount of paraffin oil, lime solution, or other approved release agent. **Petroleum distillates such as kerosene or fuel oil will not be permitted.** Each truck shall have a cover of canvas or other suitable material to protect the mixture from the weather and excessive temperature loss or cooled layers of mix in the truck, as covered in **Section 20.5C** hauling.

C. Material Transfer Vehicle (MTV):

Will be required for placement of SMA, a MTV shall be a self-propelled storage unit capable of receiving material from trucks, storing the material and transferring the material from the unit to a paver hopper insert via a conveyor system. The required paver hopper insert and unit shall have a combined minimum storage capacity of 15 tons. Prior to placing the asphalt material on the roadway surface, the storage unit or paver hopper insert must be able to remix the material in order to produce a uniform, non-segregated mix, having a uniform temperature.

D. Bituminous Pavers:

Self-propelled pavers shall be provided for full lane width paving capable of spreading and finishing the HMA material in full lane widths applicable to the typical section and thicknesses as discussed at the prepaving conference or shown in the Contract documents and shall be equipped with:

- Anti-segregation devices.
- A vibratory screed assembly capable of being heated.

Pavers used for shoulders, patching and similar construction, not requiring fine grade control, shall be capable of spreading and finishing courses of asphalt to the required widths and depths as shown in the Contract without segregation.

The paver's receiving hopper shall have sufficient capacity for a uniform spreading operation and shall have an automatic distribution system that will place and spread the mixture uniformly in front of the screed.

The paver shall be capable of operating at forward speeds consistent with uniform and continuous placement of the mixture. Stop and go operations of the paver shall be avoided. The screed or strike-off assembly shall produce the specified finished surface without tearing, shoving, segregating, or gouging the mixture. Self-propelled pavers shall be equipped with automatic screed controls with sensors capable of detecting grade provided by a source of reference line, and maintaining the screed at the specified longitudinal grade and transverse slope. The sensors may be contact or non-contact type devices. The sensor shall be constructed to operate from either or both sides of the paver and shall be capable of working with the following devices when they are required for the situation:

- Grade control device at least 30 feet in length.
- Joint matching device
- Adequate length of control line and stakes, if no other type of geometric control is present
- A straight edge at least 10 feet in length will be available to verify the crown on the screed, at the request of the **AGENCY**.

The controls shall be capable of maintaining the screed at the specified transverse slope within plus or minus 0.1 percent. Automatic mode should be used where possible. If the automatic controls fail or malfunction, the equipment may be operated manually for the remainder of the normal working day, provided specified results are obtained.

If the **CONTRACTOR** fails to obtain and maintain the specified thickness or surface tolerances, the paving operations shall be suspended until satisfactory corrections, repairs, or equipment replacements are made. Placement of HMA on a waterproofed bridge deck shall be accomplished with equipment that will not damage the membrane or protective covering the situation is corrected. Material placed that does not meet thickness or smoothness requirements shall be removed and replaced or diamond ground at the owners discretion at the Contractor's expense.

20.8 PLACEMENT

Bituminous pavement shall be placed on approved, properly constructed surfaces that are free from loose material, water, frost, snow, or ice. HMA and tack coat shall be placed in accordance with the temperature limitations of **Table 20.8-1** and only when weather conditions permit the pavement to be properly placed, finished, and compacted in accordance with the project specifications. Placement temperature shall be increased by 5 °F for each 10 miles per hour wind velocity to a maximum increased placement temperature of 70 °F as measured at the laydown location. In-place density for Asphaltic Pavement Material shall be 94 ± 2 percent of the Asphalt Mix maximum specific gravity as measured according to Maximum Theoretical Value (Rice) (AASHTO T 209). Test results will be reported to the nearest tenth of a percent, under no circumstance shall results be rounded to the nearest whole number.

TABLE 20.8-1
Minimum Air and Surface Temperatures for placement of (HMA or SMA)

| Compaction Layer Thickness | Top Layer of Pavement* | | Lower Layers * | |
|-----------------------------|------------------------|----------|----------------------|----------|
| | PG 58-28 PG 64-22 | PG 76-28 | PG 58-28 PG 64-22 | PG 76-28 |
| <2 inches (not recommended) | 60 °F | 75 °F | N/A | N/A |
| 2 inches to <3 inches | 50 °F | 65 °F | 40 °F | 50 °F |
| > 3 inches | 50 °F | 50 °F | 40 °F | 40 °F |
| SG mix only | N/A | N/A | 38 °F | 38 °F |

*Air and surface (subgrade base or previously placed AC lift) temperatures are to be taken in the shade where applicable.

The **AGENCY** shall not waive the above temperature limitations for PG 76-28.

WMA minimum ambient paving temperature requirements can be lowered 20°F but not at or below freezing. Air and surface temperatures are important and become more critical when modified binders are used.

The internal temperature of HMA and SMA shall not be placed at a temperature lower than 245 °F during placement for mixes containing PG 58-28 or PG 64-22 binder, and 290 °F for mixes containing polymer modified binder PG 76-28. Mix that is too cold or damaged by weather will be rejected.

The mixture shall be placed on an approved surface, spread and struck off to obtain the required grade and elevation after compaction. The minimum lift thickness shall be **at least three times (preferably four times) the nominal particle size**. The un-compacted mixture should be placed approximately 10-25 percent thicker than the existing surrounding mat to account for compaction based on the materials being placed.

Redistribution of the mixture using hand tools is only permitted when necessary around utilities and in areas inaccessible to equipment. Casting or raking that causes any segregation will not be permitted.

In areas where the use of mechanical spreading and finishing equipment is impractical; the mixture shall be carefully dumped, uniformly spread, raked, screeded, and luted by using hand tools to the required compacted thickness plus approximately 25 percent based on the materials being placed. Carefully move or minimally work the HMA mix with the use of rakes, lutes, or shovels to avoid segregation. Mixtures made with modified asphalt binder require more rapid completion of handwork areas than for normal mixtures.

Hauling and placement sequences shall be coordinated so that the paver is in constant motion. Bituminous pavers shall be used to distribute the mixture over the entire width or

over such partial width as may be practical. Echelon paving is encouraged. Excessive starting and stopping shall not be allowed. A construction joint shall be placed any time the paver stops, or when the screed drops enough to cause a surface dip in violation of section 20.2B, surface tolerances; or when the mat temperature falls below what is allowed in section 20.2A.

Placement of HMA on a waterproofed bridge deck shall be accomplished with equipment that will not damage the membrane or protective covering. Use of a vibratory roller will not be allowed to obtain compaction when placement of bituminous pavement on bridge deck utilizing a waterproof membrane.

A. SMA Pre-Placement:

Before proceeding with SMA placement, the **CONTRACTOR** shall demonstrate the ability to produce and place a satisfactory mix. The actual work may proceed when a full lane width demonstration control strip, having a minimum length of 1,000 feet has been successfully placed. The **CONTRACTOR** shall determine properties VMA, Voids, in-place density, and Marshall Stability of the project produced mix that is used in the demonstration control strip and provide the results to the Project Manager. No other SMA production or placement will be allowed until densities are determined. If the material in the demonstration control strip is not in close conformity with the specifications, the demonstration control strip will be removed and replaced at the Contractor's expense. The Project Manager will designate the location of the control strip.

The **CONTRACTOR** shall submit a plan for a Roller Pass Study (RPS) to the Project Manager for acceptance. Upon acceptance by the Project Manager, the **CONTRACTOR** shall perform a RPS. The plan for the RPS shall include, but is not limited to the following:

- Number, size, and type of rollers.
- Amplitude, frequency, size and speed of vibratory rollers.
- Temperature of mixture being compacted.
- Roller patterns.

For SMA the in-place density shall be determined through the completion of a Roller Pass Study (RPS) to be conducted during placement of the required 1,000 feet demonstration control strip. The RPS will determine the necessary roller compaction process needed to produce a minimum pavement density of 95.62 percent of Theoretical Maximum Density (Rice).

Density will be determined daily using the same method as during the RPS for each day of production to confirm pavement density. If a daily density check shows density below 93 percent of Rice, the **CONTRACTOR** shall stop production and the **CONTRACTOR** will again complete a RPS to establish the necessary compaction process. All subsequent daily checks that identify locations having density below 93 percent of Rice shall be removed and replaced at the Contractor's expense. A new RPS shall be completed and approved prior to resuming production.

B. SMA Placement:

SMA mixture shall be transported and placed with the use of a MTV, see **Section 20.8**, on the roadway without drain-down or flushing. All flushed areas shall be removed immediately. If there are more than 50 square feet of flushed areas within the pavement, operations shall be discontinued until the source of the flushing has been found and corrected. The **AGENCY** will designate the depth and area of all flushed areas requiring removal and replacement. All costs associated with the removal and replacement of the flushed areas shall be at the **CONTRACTOR's** expense.

SMA Pavement shall be placed and compacted in accordance with the temperatures listed in **Table 20.8-1** or as revised for the project during the pre-paving meeting.

The relative compaction for all Asphaltic Pavement Material will be measured based on cores in accordance with AASHTO T 166, Method B, unless the material being placed is on a structure (bridge deck) in which case the **AGENCY** may allow nuclear gauge measurements used.

When cores are used, the **CONTRACTOR** shall provide all labor and equipment for the coring and repair of the core holes. When nuclear density gauges are used, the tests will be performed in accordance with ASTM D 2950 and AASHTO T 230.

C. 2WMA Construction Requirements

Asphalt Manufacturing:

The asphalt manufacturing plant may be modified as required by the producer of the WMA technology.

Equipment:

WMA technology shall be capable of producing an asphalt mixture that meet specification requirements and is workable at the minimum placement and compaction temperature.

Placement:

Placement shall be the same as HMA but at lower production and placement temperatures. No pavement operations will be done when ambient paving temperatures is to below freezing.

Compaction Test Section:

A test section shall be constructed to verify compaction requirements are being met at the lower placement temperatures and the appearance of the mixture is acceptable to the **AGENCY**.

20.9 LONGITUDINAL JOINTS

Longitudinal joints in all pavement layers shall offset the joint in the layer immediately below by a minimum of six (6) inches. The joint in any pavement layer shall not fall in or between wheel paths. Joints in the top layer of new pavement shall be located on lane lines unless otherwise shown on the plans. Longitudinal joints shall be minimized with wide paving pulls, if paver is equipped with heated adjustable screed plates with augers and the ability to provide initial compaction. Hydraulic screed extensions that just strike

off the mixture are not acceptable or echelon paving. Joints shall be parallel to the flow of traffic and shall not cross any centerline, lane line, or edge line. Prior to the pre-paving meeting the **CONTRACTOR** shall submit a joint plan and pavement marking plan showing locations and the methods to establish the paving control lines. The **plan must be acceptable to the AGENCY and be developed based on the lane lines shown on the final stripping plan** prior to paving. The **CONTRACTOR** shall use a continuous string line to delineate longitudinal joints during paving. When applicable, string lines shall be removed at the end of each day's paving.

All paving shall be placed parallel to the roadway centerline and as straight as possible,. All joints shall receive a coat of tack prior to placement of adjacent paving.

When placing a layer of pavement against a previously compacted layer in an adjacent lane of pavement the edge of new layer shall not overlap the compacted layer by more than 1.5 inches. Overlap or excess thickness shall not be cast onto the new un- compacted layer but shall be pulled away from the joint and removed. The hot edge shall be bumped in a vertical smooth line consistent with the previous longitudinal edge. A minimal amount of raking will be allowed around manholes and other utilities. Longitudinal joints should be rolled from the hot side and overlap the cold joint by approximately six (6) inches.

20.10 TRANSVERSE JOINTS

Prior to paving, the **CONTRACTOR** shall submit a joint plan showing locations and the methods to be used to construct transverse joints. The **plan must be acceptable to the AGENCY** prior to paving. In areas where the use of mechanical spreading and finishing equipment is impracticable, the mixture shall be carefully dumped, spread, raked, screeded, and luted by hand tools to meet the elevation of the adjacent pavement. Placing of the HMA shall be continuous with a minimum of transverse joints, and rollers shall not pass over the unprotected end of a freshly laid mixture. Transverse joints shall be formed by cutting back on the previous run to expose the full depth of the course. Tack coat material shall be applied to contact surfaces of all joints before additional mixture is placed against the previously compacted material.

Transverse joints shall be located so they will be constructed with a full head of mix in front of the screed. When butt joints are constructed, runoff boards shall be used to support the roller on the downstream side of the joint. All tapered sections, rounded edges, and segregated areas shall be removed to achieve a vertical face at the butt joint before paving is restarted. When a temporary tapered joint is required for temporary traffic access, the ramp shall be removed back to a full depth section before paving is restarted.

When paving operations are to resume the screed of the paver should be placed on thin strips of material on the completed pavement. The strips should be of sufficient thickness so that adequate grade and compaction can be achieved on starting the paving operation. The screed should be nulled (angle removed) when starting from blocks and set in an up angle of attack. Proper head of mix should be introduced into the paver prior to starting. The new compacted (downstream) side of the joint may be up to 3/16 inches higher than the old (upstream) side. Raking of this joint shall a bump is not created by the transverse joint The surface tolerance at the transverse joint must be verified by the **CONTRACTOR** with a 10- foot straight edge before the paver is more than 50 feet from the joint. If the surface tolerance is not within the 3/16", the **CONTRACTOR** shall stop the paver and make corrections to the joint before proceeding.

20.11 SEGREGATION

Segregated areas may be determined visually, by density or gradation. The extent of the segregation will be determined visually. The **CONTRACTOR** will remove and replace or repair segregated areas at their expense to the satisfaction of the **AGENCY**.

The asphalt mixture shall be transported and placed on the roadway without segregation. All segregated areas shall be removed immediately and replaced with specification material before the initial rolling. If more than 50 square feet of segregated pavement is removed and replaced in any continuous 500 linear feet of paver width paving shall be discontinued until the source of the segregation has been corrected.

20.12 COMPACTION

The temperature of the mixture immediately behind the screed shall be sufficient to allow for proper compaction of the HMA layer and at least 245 ° F for PG 58-28 or PG 64-22 binder and between 297°F and 305° F for PG 76-28 binder. The breakdown compaction should be completed as quickly as possible after placement occurs and before the mixture temperature drops 20°F from placement temperature.

The HMA shall be compacted by rolling. Both steel wheel and pneumatic tire rollers will be required. The number, weight, and type of rollers furnished shall be sufficient to obtain the required density and surface texture while the mixture is in a workable condition. Compaction shall begin immediately after the mixture is placed and continued until the required density is obtained. Final compaction shall be obtained using steel wheel rollers.

Pavement operations shall be suspended when density requirements are not met and the surface temperature falls below 165 °F, or when there is obvious surface distress or breakage; further compaction effort shall not be applied unless approved. If the mixture contains modified asphalt cement (PG 76-28, PG 70-28, or PG 64-28) and the surface temperature falls below 230 °F, further compaction effort shall not be applied unless approved.

The minimum compaction temperatures may be adjusted according to the asphalt binder supplier recommendations. Adjusted minimum compaction temperatures must be shown on the approved mix design or on other asphalt binder supplier documents and be available on the job site. Pay Reduction criteria in **Section 20.2D** shall still apply in such cases of substandard compaction, but within the range of acceptability.

All roller marks shall be removed with the finish rolling. Use of vibratory rollers with the vibrator on will not be permitted during surface course final rolling and will not be permitted on bridge decks covered with waterproofing membrane.

The **CONTRACTOR** shall establish a rolling pattern or procedure during the beginning of paving operations, which will achieve the required compaction and surface tolerances.

This procedure may be re-evaluated by the **CONTRACTOR** and **AGENCY** throughout the paving operations.

All HMA paving shall be compacted to **94.0 ± 2** percent of Maximum Theoretical (Rice) Density, (AASHTO T 209: Maximum Specific Gravity of Bituminous Paving Mixtures) as determined by ASTM D 2950. Rice values shall be used in calculating Relative Compaction according to AASHTO T 166. Rice value(s) will be based on a three (3) production day's average. The **CONTRACTOR** shall provide the producer's Rice value, which shall be used for production

until the actual day's Rice value is determined by the testing firm of record for the project.

All joints shall be compacted to minimum of 92.0 ± 2 percent of Rice, taken six (6) inches on each side of joint, every 200 Linear Feet. Rice values shall be used in calculating Relative Compaction according to AASHTO T 166, cores if needed will be used to verify compaction results.

The **CONTRACTOR** shall core the pavement, as required by the **AGENCY**; for field density tests in accordance with AASHTO T 230, Method B, or for field calibration of nuclear density equipment in accordance with the ASTM D 2950. At a minimum, cores for nuclear density equipment calibration shall be taken at the beginning of placement of each pavement layer or change of mixture materials or gradation. Untested areas during placement will also require cores to verify compaction.

Along forms, curbs, headers, walls, and all other places not accessible to the rollers, the mixture shall be thoroughly compacted with mechanical tampers. Any mixture that becomes loose and broken, mixed with dirt, or is in any way defective, shall be immediately removed and replaced with uncontaminated hot mixture and compacted to conform to the surrounding area at the expense of the **CONTRACTOR**.

Compaction requirements for SMA are covered in **Section 20.8**. Rollers shall not be used in a vibratory mode on SMA unless they are first used successfully in the demonstration control strip. Pneumatic wheel rollers shall not be used on SMA Mix.

20.13 PRODUCTION TOLERANCES

A. Top Lift Surface Tolerances:

Surface variation between any two contacts shall not exceed 3/16 inch in 10 feet for full lane width paving. For patching surface tolerances, the variation shall not exceed 3/8 inch in 10 feet. All humps or depressions exceeding the specified tolerance shall be corrected by removing defective work and replacing it with new material or by overlaying (patching) as directed by the **AGENCY**. The final pavement surface shall not vary from the specified cross section by more than one (1) inch at any point. Irregularities exceeding the specified tolerance shall be corrected at the **CONTRACTOR's** expense. Transverse measurements for variations shall exclude breaks in the crown sections. Roadway smoothness testing will not be measured or paid for separately, but shall be included in the work.

The final surface pavement adjacent to concrete gutter shall be finished from 1/8-inch to 3/8-inches above the lip of the gutter into which it drains. Any surface pavement that is above the lip more than 3/8 inch shall be removed and replaced to the specified height. Any pavement surface that is below the lip of the gutter shall be corrected as directed by the Project Manager. This provision does not apply to "tipped" or standard median gutter but does apply to median "catch" gutters used on super-elevated roadways, but the final surface pavement adjacent to these gutters shall be finished level to the lip.

Prior to placing the surface course, the **CONTRACTOR** shall adjust all manholes, valve boxes, and survey range boxes so they are from 1/8 to 1/2- inch below finish grade after the final surface course is placed. The **CONTRACTOR** shall notify the **AGENCY** of the timing of adjustments to all manholes and valve boxes so he may observe. The **CONTRACTOR** shall remove any foreign matter introduced into all

manholes and valve boxes during construction. It shall also be the Contractor's responsibility to insure proper compaction around all manholes and valve boxes after they have been raised. At no time shall manholes and valve boxes be covered up or buried. Valve boxes and manholes are to be maintained fully accessible at all times for emergency and maintenance operation by City personnel. The cost of adjusting valve boxes, manholes, and survey range boxes shall be included in the work, unless otherwise specified in the Special Conditions or Proposal. The **CONTRACTOR** shall be responsible for any cost incurred by the **AGENCY** to provide access to the covered manholes or valve boxes. Valve boxes, manholes, and survey range boxes shall be clean when work is completed. Valve boxes, manholes, and survey range boxes shall be adjusted to match the slope of the roadway. Final adjustment of all utility access points shall be completed within seven (7) days of from the time the roadway pavement was placed.

B. Job Mix Formula Tolerances:

For production test results that deviate from the design job mix by more than shown in the following table are subject to this section:

**TABLE 20.13B-1
Job Mix Formula Tolerances**

| Mixture Grading | ST (3/8" Nominal) | | SX (1/2" nominal) | | S (3/4" nominal) | | SG (1" nominal) | |
|------------------|--|-----------|-------------------------------|-----------|----------------------------|-----------|-----------------|-----------|
| Traffic Loading, | Repair Segregation Bike path Sidewalk | | Low To Medium 0 to 300,000 | | Medium To High >300,000 | | Lower lifts | |
| Sieve Size | Control Points | Tolerance | Control Points | Tolerance | Control Points | Tolerance | Control Points | Tolerance |
| 1 1/2" | | | | | | | 100 | + 1% |
| 1" | | | | | 100 | + 1% | Design | ± 6% |
| 3/4" | | | 100 | + 1% | Design | ± 6% | Design | ± 6% |
| 1/2" | 100 | + 1% | Design | ± 6% | Design | ± 6% | Design | ± 6% |
| 3/8" | Design | ± 6% | Design | ± 6% | Design | ± 6% | Design | ± 6% |
| #4 | Design | ± 5% | Design | ± 5% | Design | ± 5% | Design | ± 5% |
| #8 | Design | ± 5% | Design | ± 5% | Design | ± 5% | Design | ± 5% |
| #16 | Design | ± 4% | Design | ± 4% | Design | ± 4% | Design | ± 4% |
| #30 | Design | ± 4% | Design | ± 4% | Design | ± 4% | Design | ± 4% |
| #50 | Design | ± 4% | Design | ± 4% | Design | ± 4% | Design | ± 4% |
| #200 | Design | ± 2% | Design | ± 2% | Design | ± 2% | Design | ± 2% |
| Air Voids | Design | 3.0-5.0% | Design | 3.0-5.0% | Design | 3.0-5.0% | Design | 3.0-5.0% |
| VMA | Design | ± 1.2% | Design | ± 1.2% | Design | ± 1.2% | Design | ± 1.2% |
| Hveem Stability | See Table 20.3A-1 | | | | | | | |

| | | | | | | | | |
|-----------------|--------|--------|--------|--------|--------|--------|--------|--------|
| Asphalt Content | Design | ± 0.3% | Design | ± 0.3% | Design | ± 0.3% | Design | ± 0.3% |
|-----------------|--------|--------|--------|--------|--------|--------|--------|--------|

(Note 1) There is 1.0 percent tolerance for the maximum sieve size.

(Note 2) Mixes with passing No. 200 sieve material produced over 7.0 percent are allowed only when the above Air Voids and VMA tolerances are still met.

(Note 3) Hveem Stability must meet the minimum value specified in **Table 20.3A-2**

(Note 4) When calculating VMA, use the most current aggregate specific gravity G_{sb} .

When disagreements concerning determination of specification compliance occur, only valid tests from all testing parties may be considered. Valid tests are those in which sampling and testing have been performed according to referenced procedures and the results are within applicable precision statements. When disagreements occur with asphalt content and gradation tests results, solvent extracted aggregate testing shall take precedence over burn off oven extracted aggregate, which shall take precedence over cold feed belt testing.

20.14 CONFORMITY WITH PLANS AND SPECIFICATION

A. General

All work performed and all materials furnished shall conform to the lines, grades, cross sections, dimensions, and material requirements, including tolerances, shown or stated in the contract documents.

When tolerances are not specified, the **CONTRACTOR** shall perform the work in a manner consistent with reasonable and customary manufacturing and construction practices.

When the **AGENCY** finds that the materials furnished, the work performed, or the finished product does not conform with the contract, but that reasonably acceptable work has been produced, the **AGENCY** shall determine the extent of the work to be accepted and remain in place.

Cost reduction, when allowed, shall be accomplished by adjusting pay quantities as indicated herein and applying contract unit prices to the reduced quantities. If the work is to be accepted, the **AGENCY** will:

- Document the basis for acceptance by "Cure Notice" which may provide for an appropriate adjustment in the payment quantity for such work or materials not otherwise provided for in this section.
- Notify the **CONTRACTOR** in writing that the payment may be adjusted in accordance with this section when "P" is 25 or less, or require appropriate remediation to be performed.

In lieu of cost (quantity) adjustment, permit correction or replacement of the finished product provided the correction or replacement does not adversely affect the work or the **AGENCY**.

When the **AGENCY** determines that the material furnished, work performed, or the finished product is not in conformity with the contract and has resulted in inferior or unsatisfactory product, the finished product or materials shall be removed and

replaced or otherwise corrected by, and at the expense of, the **CONTRACTOR**.

Materials shall be sampled and tested by a qualified testing laboratory in accordance with the sampling, testing schedules, and procedures contained in the **Section 20.2D** Testing and Inspection. The approximate maximum quantity represented by each sample shall be as set forth in the testing schedule. An additional number of samples, in relation to the quantity of materials represented, may be selected and tested at the Agency's discretion. The quantity represented by five consecutive random samples shall constitute a lot, whenever production schedules and material continuity permits. When it is necessary to represent short production runs, significant material changes, or other unusual characteristics of the work, the **AGENCY** may establish a lot consisting of the quantity represented by any number of consecutive random samples from one to seven inclusive. Testing results that are determined to have sampling or testing errors, as determined by the **AGENCY**, shall not be used.

B. Pavement Thickness Deficiencies

If the full depth cores indicate a thickness deficiency, additional cores will be taken by the Contractor to be given to the Agency so that price reductions can be determined per Lot. A Lot encompasses 250 lineal lane feet or the quantity between tests, and a price reduction shall be determined as a percentage of the bid unit cost of the Asphalt Pavement.

Asphalt Pavement thickness will be determined from cores secured from each sub-lot for this purpose. Such cores will be taken and measured by the Asphalt Concrete Coring Method.. Each core location will be patched by the party responsible for the testing.

- (1) If the pavement thickness is deficient from the target thickness by 0.25 inches or less, it will be paid for at the contract unit price. If the pavement thickness deficiency is greater than 0.25 inches and the contracting **AGENCY** is not the owner (i.e. permits) the following steps will apply: If the core thickness indicate a deficiency in the pavement exceeds 0.25 inch, the limits of the deficient area will be isolated evaluated by coring at maximum intervals of 100 feet from the deficient core. The thicknesses of the original deficient core will be averaged with the thicknesses of the cores taken from 100 feet on each side of it to determine compliance with the acceptance requirements. **If the resulting average thickness deficiency is greater than 0.25 inch, then Table 20.14H-1 shall apply to the sub-lot. Additional cores may be required to define the limits of the deficient area, and shall not be used for re-evaluating acceptance.**
- (2) If the pavement thickness from step one above deviates from the target thickness by more than 0.25 inch but not more than 0.50 inch, corrective action will be required. This corrective action will consist of application of a Type II slurry seal coat in accordance to Item 26 (Slurry Seal). The **CONTRACTOR** may present an engineering analysis outlining other proposed remedial measures for the consideration of the Engineer. The Engineer will review the engineering analysis and decide within 30 working days whether to accept the proposed remedial measures.

- (3) If the pavement thickness from step one above deviates from the target thickness by more than 0.50 inch, corrective action will be required. The deficient area will be overlaid with no less than 1 inch thick lift, for the full width of the pavement to meet or exceed the designed thickness, with the appropriate end and edge milling, with a mixture approved by the Engineer. The **CONTRACTOR** may present an engineering analysis outlining other proposed remedial measures for the Engineer's consideration. The Engineer will review the engineering analysis and decide within 10 working days whether to accept the proposed remedial measures. If the Engineer chooses to reject the engineering analysis, the indicated overlay will be constructed by the **CONTRACTOR** at no additional cost to the Owner.

If the pavement thickness deficiency is greater than 0.25 inches and the contracting **AGENCY** is the owner, **Table 20.14H-1** will apply.

C. Use of Cores to determine acceptable asphalt thickness

All cores shall be no more than 0.25-inch deficient than the required thickness shown on plans or pavement design report for full payment or acceptance. A minimum of 90% of all the pavement thickness cores must equal or exceed the required thickness shown on plans or pavement design report for full payment or acceptance... Any deficient pavement thickness shall be dealt with is listed on **Table 20.14H-1**

D. Verification of Thickness and Remedial Action

When the **AGENCY** determines that deficient thickness exists, the **CONTRACTOR** may define the deficient section boundaries by any means acceptable to the **AGENCY**, and then verify the boundaries to the satisfaction of the **AGENCY** at the boundary, or by direct measurement when cutting the pavement.

When the **AGENCY** determines that they do not want the top lift cored, they shall require the **CONTRACTOR** to use non-destructive survey techniques to determine top lift thickness. This shall be combined with core information taken from lower lifts to determine total pavement thickness.

The **CONTRACTOR** will be responsible for coring of the Asphaltic Pavement and notifying the **AGENCY** of the coring operations, so they may be present to observe. Duplicate cores will be required. The **CONTRACTOR** will retain one set and the Agency shall receive the other set for comparison testing.

Referee: In the event the **CONTRACTOR** elects to question the acceptance test results for either asphalt binder content, laboratory air voids, density, thickness, or a combination thereof for a lot, the **CONTRACTOR** may make a written request for additional testing of that lot. Any request for referee testing must describe the Contractor's reasons for questioning the validity of the original acceptance results and must clearly describe which set of acceptance tests are in question. The **CONTRACTOR** will engage an independent laboratory (at their own expense) who is accredited by AMRL in all of the acceptance test methods. The independent laboratory shall be acceptable to the engineer and shall perform a complete new set of acceptance tests (as required to represent the area or set of tests in

question). The results of these determinations will be binding on both the **CONTRACTOR** and the **AGENCY**. If the test results obtained by the independent laboratory result in elimination or reduction of the magnitude of the applicable penalty the contracting **AGENCY** will bear the cost of the referee testing. If the applicable penalty remains unchanged or increases, the cost for verification testing will be deducted from payments that were to be made to the **CONTRACTOR**.

These tests may include asphalt binder content, aggregate gradation, Gyratory unit weight, maximum theoretical unit weight, laboratory air voids, and in-place air voids (compaction). Samples for referee testing shall come from representative samples obtained from the completed pavement.

The number of samples taken will be the same as specified. The independent laboratory shall compile the test results and transmit them to both the **AGENCY** and the **CONTRACTOR**. The independent laboratory shall include a report signed by an engineer registered in the State of Colorado, who is experienced in asphalt concrete testing and mix design development. The signed report shall give an opinion that the material evaluated either does or does not comply with project specifications, will clearly describe any deficiencies, and the results will be binding between all parties.

E. Price Reductions on Thickness

Price reductions shall not be allowed for Thickness deficiencies on projects to be accepted from developers. Remedial action is required of the **CONTRACTOR** to the satisfaction of the **AGENCY** to meet the design thickness requirements. Extended warranty will not be an acceptable alternate to remedial action.

For an Agency's Capital Project, the **AGENCY** may elect to apply a linear price reduction based on pavement thickness in lieu of remedial action using a base number that equates to 4% deficiency in thickness to 25% reduction of traffic capacity over the design life hence justification for a similar payment reduction.

F. Average Core Thickness

If the average core thickness is greater than or equal to the specified core thickness, the **AGENCY** will not apply a payment reduction/incentive. If the average thickness is less than the specified thickness, but is greater than or equal to the specified thickness minus 1/4 inch, the Agency will determine payment reduction by the following formula:

$$\text{Payment Reduction} = Q \times BP \times \text{PPR}$$

Where:

| | |
|-------|--|
| Q= | Thickness Lot Quantity (Tons or square yard) |
| BP = | Bid Price (\$/ton) |
| TS = | Specified thickness. |
| TA = | Average thickness |
| PPR = | Percent payment reduction = $\frac{TS - TA}{TS}$ |

G. Individual Core Thickness

When more than 2 individual cores in the lot are less than the specified thickness minus 1/4 inch, the Agency will determine the payment reduction using for the

above noted formula and using an initial PPR = 2 percent.

H. Remove and Replace

If the average thickness is less than the specified thickness minus 1/2 inch, the Agency will require that the lot be removed and replaced.

**TABLE 20.14H-1
Price Reduction – Thickness**

| Thickness and Remedial action | ACTION TO BE TAKEN |
|--|--|
| Average core thickness is greater than or equal to the specified core thickness. | <u>NO payment reduction/incentive will apply</u> |
| Average thickness is less than the specified thickness, but is greater than or equal to the specified thickness minus 1/4 inch | Determine payment reduction by the following formula or remediation of pavement |
| If the average thickness is less than the specified thickness minus 1/2 inch. | Remove and Replace |

* Price reductions are not applicable to developer projects, as a financial deterrent, but may be used as a determination for acceptance.

I. Cost Reduction Formula

Materials or work shall only be evaluated for price adjustment when deviations from specifications occur on any of the individual tests for the lot. Several individual test values shall be averaged and the percentage of cost (quantity) reduction for the lot shall be determined by applicable formula. This shall apply only when a cost reduction factor "F" for the element is listed in **Table 20.13-3**.

When the Lot is represented by three through seven Tests the formula in (1) and (2) below shall be used.

- 1) $P = (X_n + aR - Tu) * F$ Shall be used if a maximum limit only is specified or; when the average of the several test values is above the midpoint of the specification band or above the job-mix formula value.
- 2) $P = (TL + aR - X_n) * F$ shall be used if the minimum limit only is specified or; when the average of the several test values is below the midpoint of the specification band or below the job-mix formula value.

When the lot is represented by fewer than three tests, **the** materials shall be evaluated for cost (quantity) reduction by the following procedure: Lots represented by two tests shall be divided into two separate lots represented by one test each, as determined by the Agency. Each lot that deviates from the specifications shall be cost adjusted by one of the following formulas.

- 3) $P = 0.76 * (To - Tu) * F$ When a maximum limit only is specified or the test value is above the maximum specified limit.
- 4) $P = 0.76 * (TL - To) * F$ When a minimum limit only is specified or the test value is below the minimum specified limit.

Where:

- P** is the percentage of reduction in payment quantity.
- X_n** is the average of the several test values from samples taken from the lot, with "n" indicating the number of values.
- a** is a variable factor to be used if "n" changes according to the following:

**TABLE 20.14I-1
Cost Reduction Factors**

| when "n" is | "a" equals |
|--------------|------------|
| 3 | 0.45 |
| 4 | 0.38 |
| 5 | 0.33 |
| 6 | 0.30 |
| 7 or greater | 0.28 |

R is the difference between the highest and lowest values in the group of several test results from the lot.

T_u is the upper or maximum tolerance limit permitted by the specifications.

T_L is the lower or minimum tolerance limit permitted by the specifications.

T_o is the test value of the test that deviates from the specifications.

F is the cost reduction factor to be applied for each element as shown in **Table 20.14I-2**

**TABLE 20.14I-2
Price Reduction Factors**

| ELEMENT | FACTOR "F" |
|---|--------------------|
| 100 percent size sieve | 1 |
| 1/2 inch sieve and larger | 1 |
| 3/8 inch sieve, #4, #8, #30 sieves No. 100 | 3 |
| No. 200 sieve | 6 |
| Density of Hot Mix Asphalt | 8 |
| Asphaltic Cement Binder content (all asphalt-aggregate mixtures) | 10 |
| Total air voids | 5 |
| Voids in mineral aggregate | Informational Only |
| Stability | 5 |

If "**P**" is less than three (3) or a negative quantity, the material shall be accepted as being in conformity. In cases where one or more elements show a positive "**P**" value, such positive values shall be added and the resulting sum shall be used to determine whether the material is in conformity. If the total "**P**" value is between 3 and 25, the **AGENCY** may require correction or may accept the material at a reduced cost. If "**P**" is greater than 25, the **AGENCY** may:

Require complete removal and replacement with specification material at no additional cost to the **AGENCY**;

Require corrective action to bring the material into conformity at no additional cost to the **AGENCY**;

Where finished product is found to be capable of performing the intended purpose and the value of the finished product is not affected, permit the **CONTRACTOR** to leave the material in place with an appropriate cost adjustment to be based on the Agency's evaluation but not less than that which would have occurred had an adjustment been made where "P" = 25.

If binder content, aggregate sieve analysis, or compaction deviates from the specification requirements and the total "P" is three or greater, the reduction shall apply to the contract cost (quantity) multiplied by 0.60 for aggregate base course and Hot Bituminous Pavement mixtures.

The **CONTRACTOR** shall not have the option of accepting a cost reduction in lieu of intentionally producing material not meeting specification. Continued production of non-specification material shall not be permitted. Material that is defective as identified by visual inspection shall be isolated and rejected without regard to sampling sequence or location within a lot.

20.15 TESTING AND INSPECTION

If any materials furnished or work performed fails to fulfill the specification requirements, such deficiencies shall be reported to the Agency immediately. Written field reports prepared by Geotechnical consultants and contractors of all tests taken and observation results shall be delivered to the **AGENCY** within 3 business days after samples were obtained or density testing performed. Reports of in place density using rice values from samples taken during construction or other test results that cannot be reported within 3 days of construction shall be provided to the **AGENCY** no later than 1 week following the testing.

Reports of all tests taken, including failing tests, shall be reported to the **AGENCY** no later than 1 week following the sampling. Density test results will be provided to the **AGENCY** at the time the testing occurs.

Failing Test results must reported to the **AGENCY** representative and **CONTRACTOR** **immediately**.

Testing of Hot Mix Asphalt Pavement shall be performed in accordance with **Table 20.15-1** and **Table 20.15-2**. Laboratories shall be accredited by AASHTO for the material being tested. Technicians taking samples and conducting compaction tests must have a LabCAT Level A certification or equivalent. Technicians conducting tests of asphalt content and gradation must have a LabCAT Level B certification or equivalent. Technicians performing volumetric testing must have a LabCAT Level C certification or equivalent.

TABLE 20.15-1
Minimum Materials Sampling and Testing for all Asphalt Pavement

| Test | Standard* | Minimum Frequency |
|--|---|---|
| Sampling | AASHTO T168, ASTM D 979 and ASTM D3665 | 1/1000 tons or fraction thereof (not less than one test per day) |
| Density | AASHTO T 166, T 238, T 230 | One test for each 250 lineal feet per Lane |
| Thickness (Core) | ASTM D3549 | One test for each 1000 lineal feet per Lane, |
| Air Voids & VMA | AASHTO T 166 & AASHTO PP 19 | 1/1000 tons or fraction thereof (not less than one test per day) Table 20.3A-2 |
| Gradation | AASHTO T 27, T 11 | 1/1000 tons or fraction thereof (not less than one test per day) |
| Hveem/Marshall Stability As Applicable | AASHTO T 245, AASHTO T-246 | 1/1000 tons or fraction thereof (not less than one test per day) |
| Asphalt (AC) Content | AASHTO T 164 or other methods agreed upon between Agency and Contractor | 1/1000 tons or fraction thereof (not less than one test per day) |
| Maximum Theoretical Specific Gravity (Rice) | AASHTO T 209 | 1/1000 tons or fraction thereof (not less than one test per day) |
| Lottman Stripping, TSR & Dry Density | AASHTO T 283 | One per project per mix used.** |
| Micro Deval | AASHTO T 327 | One per 5000 tons or 1 per project minimum |
| Determining the Rheological Properties of Asphalt Binder | AASHTO TP5 | One per 20,000 tons or 1 per project minimum per mix designed used. |

*Agency may determine the method used (CP vs. AASHTO).

**QC/QA must verify presents of lime used within mix. (by visual observation)

The **CONTRACTOR** shall provide assistance, at all facilities and at the job site, to inspectors whose duties shall include checking temperatures of mix in the truck and on pavement, segregation, rolling patterns and other construction means and methods that affect the performance of the pavement system. The **CONTRACTOR** shall provide assistance in sampling and testing at all facilities and at the job site.

The HMA or SMA mix design must be approved by the **AGENCY** before any pavement is placed on the project. In addition, the **CONTRACTOR** shall provide field control testing during production of the SMA mix and for the demonstration control strip. The **CONTRACTOR** shall perform the following tests and provide the results to the **AGENCY** during production:

If a Superpave SMA mix design is used, the **CONTRACTOR** shall perform the following tests and provide the results to the **AGENCY** during production:

TABLE 20.15-2
Minimum Materials Sampling and Testing for SMA Pavement

| Superpave Mix Property | Frequency |
|---|----------------------------------|
| Draindown (AASHTO T 305) | 1/1,000 tons or fraction thereof |
| Percent Voids in the total mix @ $N_{(design)}$ | 1/1,000 tons or fraction thereof |
| VMA (Percent Voids in the Mineral Aggregate) @ N_{design} | 1/1,000 tons or fraction thereof |
| Lottman, AASHTO T 283, Method B | 1/5,000 tons or fraction thereof |
| Dry Tensile Strength, AASHTO T 283 | 1/5,000 tons or fraction thereof |
| Percent AC & Aggregate Gradation AASHTO T 308 | 1/1,000 tons or fraction thereof |

20.16 PAYMENT

HMA shall be measured by the square yard at the compacted depths specified on the plans or as directed by the Project Manager. Accepted quantities of hot bituminous pavement shall be paid for at the contract price per square yard of the type, grading, and thickness specified, complete and in place according to the Conformity with Plans and Specification. The contract price per square yard shall include full compensation for all labor, materials, and equipment necessary to complete the work. If the final pavement surface varies from the theoretical cross section by more than specified tolerances, 25% of the payment due for the entire pavement width and for the full depth of the pavement and base shall be withheld until corrections are made.

Mix design, furnishing, hauling, preparing, and placing all materials, including aggregates, asphalt binder, limestone dust, hydrated lime, tack coat, and approved demonstration control strip; labor, equipment tools, setting of lines and guides where specified, and all other work necessary to complete the item will not be paid for separately but shall be included in the work.

Emulsified asphalts and liquid asphalts shall be measured by the gallon. Emulsions will be measured prior to the addition of water.

**TABLE 20.16-1
Payment**

| Item | Description | Payment |
|-------------|---------------------------|-------------------------|
| 20.1 | Asphalt Pavement Material | \$ per SY of spec depth |
| | | Tons placed |
| 20.1a* | Emulsified Tack Coat | Inclusive to Pavement** |
| | | \$ per Gallon |
| 20.2*** | Stone Matrix Asphalt | \$ per SY of spec depth |
| | | Tons placed |

*When the cost of the tack coat is a separate bid item.

**Cost of Tack Coat is to be inclusive within the Asphalt placement.

***Stone Matrix Asphalt will be measured by either Tons or SY of work completed and accepted.

Contract Control No. 2021-PROJMSTR-0000693

May 24, 2022

APPENDIX G

PRE-DIG CHECKLIST



CONNECT WITH US | 311 | POCKETGOV.COM | DENVERGOV.ORG | DENVER 8 TV

Pre-Dig Checklist for Contractors

| INFORMATION | |
|-----------------------------------|--|
| Project | |
| Project Name | |
| Telephone number: | |
| Superintendent or Project Manager | |

| CHECKLIST | | YES | NO | N/A |
|--------------------------|---|-----|----|-----|
| <input type="checkbox"/> | City Project Inspector and Project Manager were notified a minimum of 10 days in advance of any soil disturbing activities. | | | |
| <input type="checkbox"/> | Contractor has posted the DIG SAFE Poster in trailer. | | | |
| <input type="checkbox"/> | Contractor has developed a project-specific Health and Safety Plan? | | | |
| <input type="checkbox"/> | If yes, Contractor has hired a Health and Safety Officer and he/she has reviewed the project-specific Health and Safety Plan. | | | |
| <input type="checkbox"/> | If no, Contractor's field representative has read the City and County of Denver's Safety and Health Manual. | | | |
| <input type="checkbox"/> | Has the Contractor's field representative read the City and County of Denver's Standard Materials Management Plan and/or project-specific Materials Management Plan? | | | |
| <input type="checkbox"/> | Has the Contractor's field representative read the City and County of Denver's Regulated Asbestos-Contaminated Soil (RACS) Standard Operating Procedure? | | | |
| <input type="checkbox"/> | Has the Contractor's and Subcontractor's personnel who will be completing any soil disturbing activities completed the required on-line RACS training video, passed the associated exam and submitted certificates to the project manager? Link to RACS video below: https://www.denvergov.org/Government/Departments/Public-Health-Environment/Environmental-Quality/Land-Use-and-Planning/Regulated-Asbestos-Contaminated-Soils-RACS | | | |
| <input type="checkbox"/> | If there is reasonable suspicion that RACS or ACM (asbestos-containing materials) may be encountered during soil disturbing activities, the Contractor has hired a Certified Asbestos Building Inspector (CABI) who will be present for all soil disturbing activities. | | | |
| <input type="checkbox"/> | The Contractor has verified that all field personnel has completed Two-Hour Asbestos Awareness Training. | | | |
| <input type="checkbox"/> | The Contractor's field representative completed Tailgate training with all personnel associated with trenching or digging. | | | |

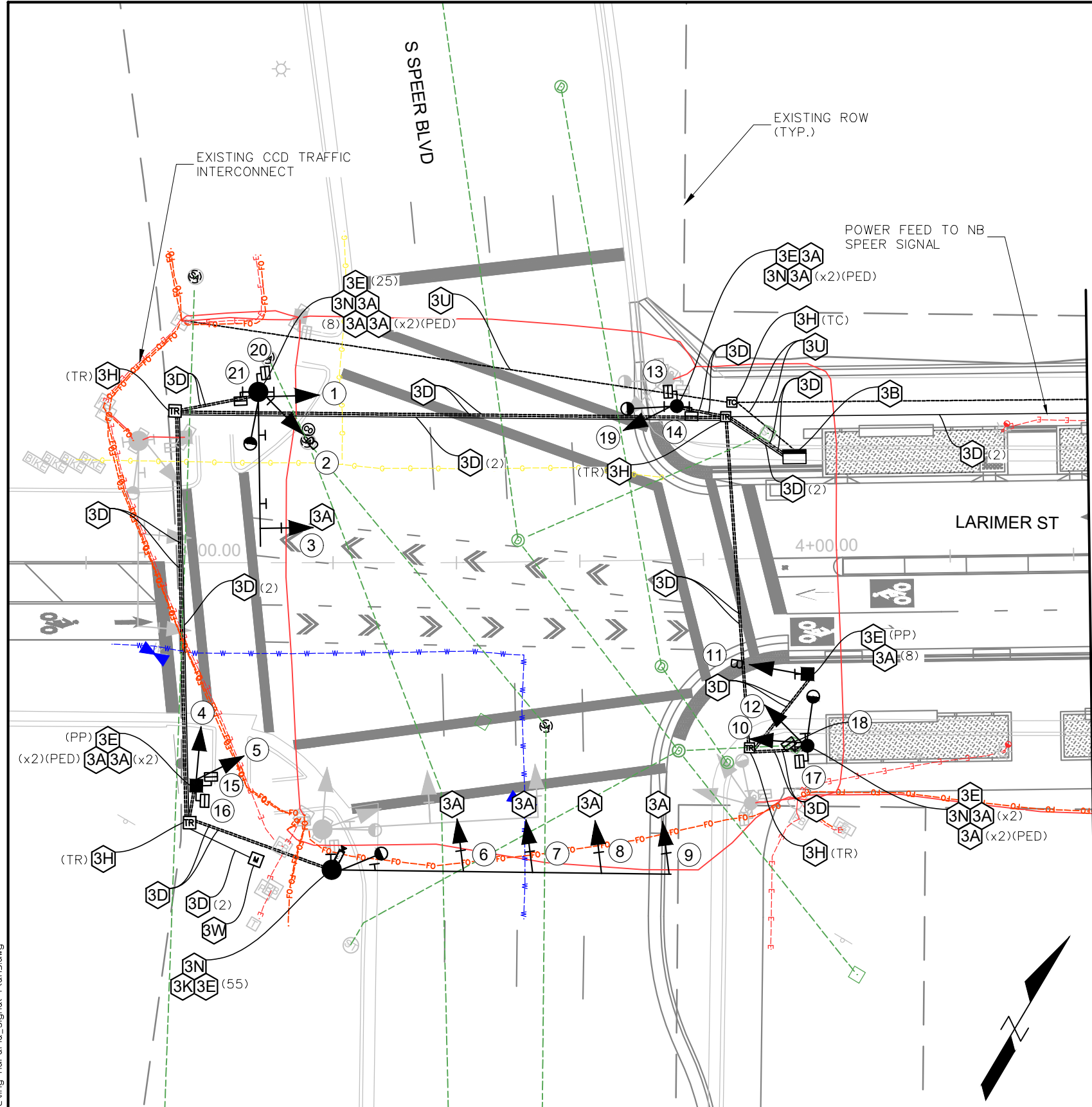

MATCHLINE STA. 4+42.60

| ITEM NO. | KEY | ITEM | UNIT | QUANTITY |
|-----------|----------|--|------|----------|
| 503-00024 | | DRILLED SHAFT (24 INCH) | LF | 14 |
| 503-00036 | | DRILLED SHAFT (36 INCH) | LF | 26 |
| 613-00200 | 3D (2) | 2 INCH ELECTRIC CONDUIT | LF | 233 |
| 613-00300 | 3D | 3 INCH ELECTRIC CONDUIT | LF | 572 |
| 613 | 3U | INTERCONNECT 3-INCH ELECTRIC CONDUIT | LF | 160 |
| 613 | 3H (TR) | PULL BOX TYPE B (TRAFFIC) | EA | 4 |
| 613 | 3H (TC) | PULL BOX TYPE C (TRAFFIC COMM) | EA | 1 |
| 613 | 3N | LUMINAIRE (LED) (5300 LUMENS)(55 WATT) | EA | 4 |
| 613-10000 | | WIRING | LS | 1 |
| 613-50109 | 3W | ELECTRIC METER PEDESTAL CABINET AND BASE | EA | 1 |
| 614-70117 | 3A (PED) | PEDESTRIAN SIGNAL FACE (16) | EA | 8 |
| 614-70324 | 3A (8) | TRAFFIC SIGNAL FACE (8-8-8) | EA | 2 |
| 614-70336 | 3A | TRAFFIC SIGNAL FACE (12-12-12) | EA | 11 |
| 614-72855 | 3B | TRAFFIC SIGNAL CONTROLLER AND CABINET | EA | 1 |
| 614-81000 | 3E | TRAFFIC SIGNAL-LIGHT POLE STEEL | EA | 2 |
| 614-81125 | 3E (25) | TRAFFIC SIGNAL-LIGHT POLE STEEL (1-25 FOOT MAST ARM) | EA | 1 |
| 614-81155 | 3E (55) | TRAFFIC SIGNAL-LIGHT POLE STEEL (1-55 FOOT MAST ARM) | EA | 1 |
| 614-84100 | 3E (PP) | TRAFFIC SIGNAL PEDESTAL POLE ALUMINUM | EA | 2 |
| 614-86105 | | TELEMETRY (FIELD) | EA | 1 |
| 614 | | EMERGENCY VEHICLE TRAFFIC SIGNAL PRIORITY CONTROL SYSTEM | EA | 1 |
| 614-87333 | 3K | CLOSED CIRCUIT TELEVISION CAMERA (TRAFFIC SURVEILLANCE) | EA | 1 |

SIGNAL HEAD LEGEND

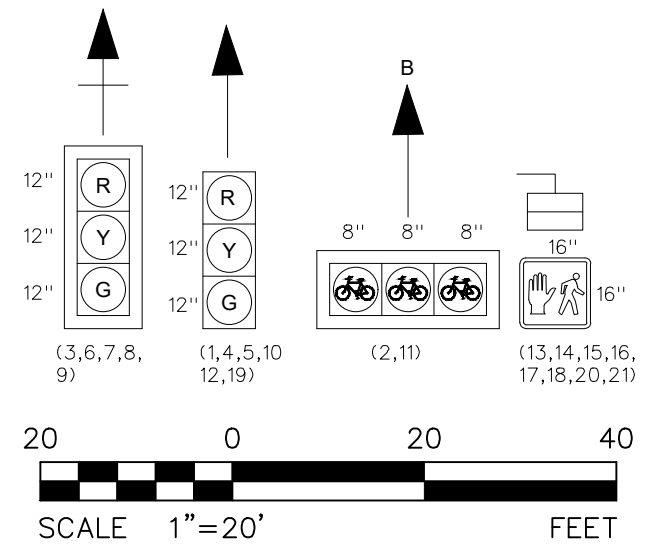

PHASE DIAGRAM

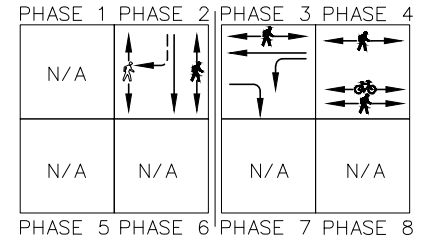

LEGEND

- TURNING MOVEMENT W/ CONFLICT
- TURNING MOVEMENT W/NO CONFLICT
- THROUGH MOVEMENT
- 2-WAY BIKE PHASE (PROTECTED)
- PED PHASE (W/ PERMITTED RIGHT TURN CONFLICT)
- PED PHASE (NO TURN CONFLICT)

Print Date: 7/27/2022
 File Name: Connecting Auraria_Signal Plans.dwg
 Horiz. Scale: 1:20 Vert. Scale: As Noted

| Sheet Revisions | | |
|-----------------|----------|-------|
| Date: | Comments | Init. |
| | | |
| | | |

DEPARTMENT OF TRANSPORTATION & INFRASTRUCTURE
 201 WEST COLFAX AVENUE
 DENVER, CO 80202
 PHONE: (720) 913-4501
 FAX: (720) 913-4544

As Constructed
 No Revisions:
 Revised:
 Void:

CONNECTING AURARIA TRAFFIC SIGNAL PLAN

Designer: KPM
 Detailer: KPM
 Sheet Subset: TRAFFIC
 Structure Numbers:
 Subset Sheets: 1 of 3

Project No./Code
 Sheet Number

C:\wip\w\0456331\Connecting_Auraria_Signal_Plans.dwg

WILSON & COMPANY
 ENGINEERS & ARCHITECTS
 990 S Broadway, Suite 220
 Denver, CO 80209
 (303) 297-2976 main
 (303) 297-2693 fax
 www.wilsonco.com

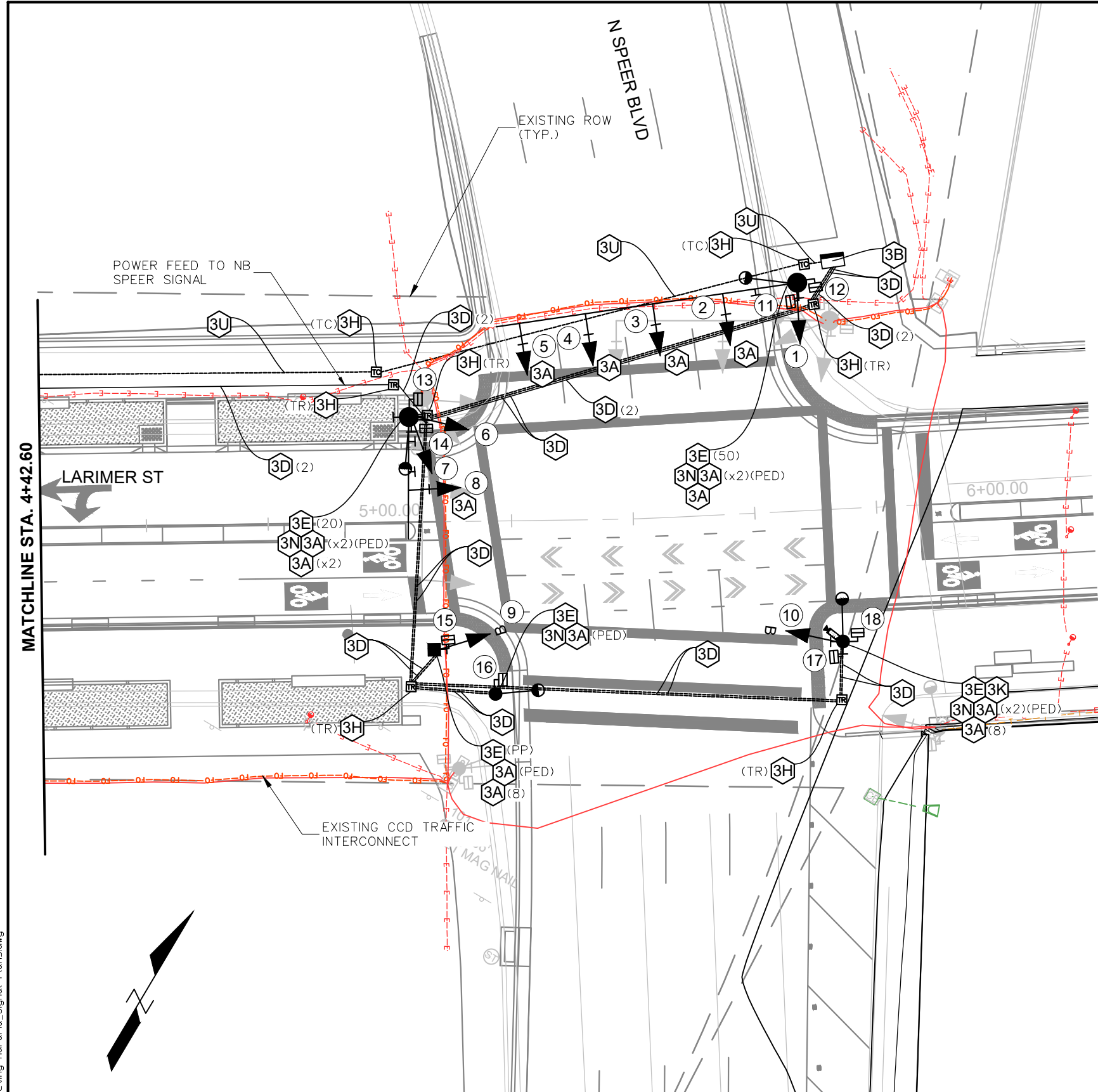

| ITEM NO. | KEY | ITEM | UNIT | QUANTITY |
|-----------|----------|--|------|----------|
| 503-00024 | | DRILLED SHAFT (24 INCH) | LF | 14 |
| 503-00036 | | DRILLED SHAFT (36 INCH) | LF | 26 |
| 613-00200 | 3D (2) | 2 INCH ELECTRIC CONDUIT | LF | 137 |
| 613-00300 | 3D | 3 INCH ELECTRIC CONDUIT | LF | 430 |
| 613 | 3U | INTERCONNECT 3-INCH ELECTRIC CONDUIT | LF | 129 |
| 613 | 3H (TR) | PULL BOX TYPE B (TRAFFIC) | EA | 5 |
| 613 | 3H (TC) | PULL BOX TYPE C (TRAFFIC COMM) | EA | 2 |
| 613 | 3N | LUMINAIRE (LED) (5300 LUMENS)(55 WATT) | EA | 4 |
| 613-10000 | | WIRING | LS | 1 |
| 614-70117 | 3A (PED) | PEDESTRIAN SIGNAL FACE (16) | EA | 8 |
| 614-70324 | 3A (8) | TRAFFIC SIGNAL FACE (8-8-8) | EA | 2 |
| 614-70336 | 3A | TRAFFIC SIGNAL FACE (12-12-12) | EA | 8 |
| 614-72855 | 3B | TRAFFIC SIGNAL CONTROLLER AND CABINET | EA | 1 |
| 614-81000 | 3E | TRAFFIC SIGNAL-LIGHT POLE STEEL | EA | 2 |
| 614-81120 | 3E (20) | TRAFFIC SIGNAL-LIGHT POLE STEEL (1-20 FOOT MAST ARM) | EA | 1 |
| 614-81150 | 3E (50) | TRAFFIC SIGNAL-LIGHT POLE STEEL (1-50 FOOT MAST ARM) | EA | 1 |
| 614-84100 | 3E (PP) | TRAFFIC SIGNAL PEDESTAL POLE ALUMINUM | EA | 1 |
| 614-86105 | | TELEMETRY (FIELD) | EA | 1 |
| 614 | | EMERGENCY VEHICLE TRAFFIC SIGNAL PRIORITY CONTROL SYSTEM | EA | 1 |
| 614-87333 | 3K | CLOSED CIRCUIT TELEVISION CAMERA (TRAFFIC SURVEILLANCE) | EA | 1 |

SIGNAL HEAD LEGEND

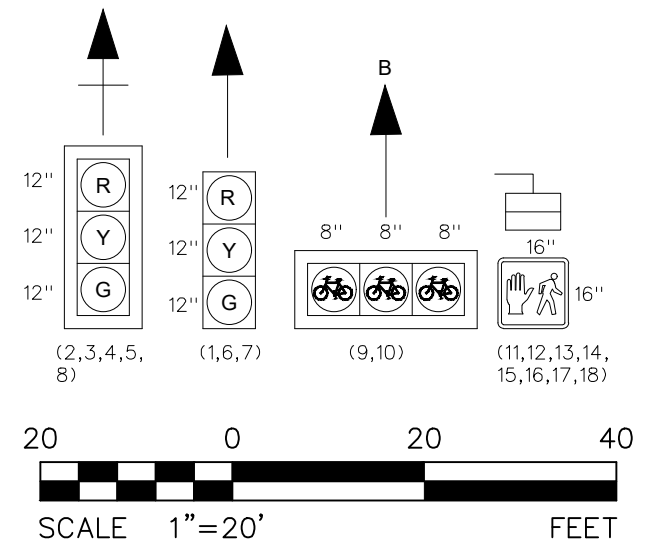

PHASE DIAGRAM

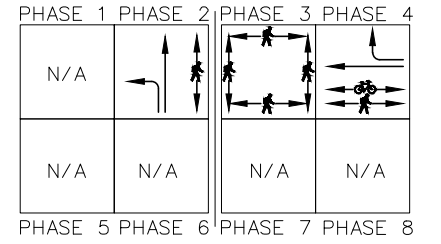

LEGEND

- TURNING MOVEMENT W/ CONFLICT
- TURNING MOVEMENT W/NO CONFLICT
- THROUGH MOVEMENT
- 2-WAY BIKE PHASE (PROTECTED)
- PED PHASE (W/ PERMITTED RIGHT TURN CONFLICT)
- PED PHASE (NO TURN CONFLICT)

Print Date: 7/27/2022
 File Name: Connecting Auraria_Signal Plans.dwg
 Horiz. Scale: 1:20 Vert. Scale: As Noted

| Sheet Revisions | | |
|-----------------|----------|-------|
| Date: | Comments | Init. |
| | | |
| | | |

DEPARTMENT OF TRANSPORTATION & INFRASTRUCTURE
 201 WEST COLFAX AVENUE
 DENVER, CO 80202
 PHONE: (720) 913-4501
 FAX: (720) 913-4544

| |
|----------------|
| As Constructed |
| No Revisions: |
| Revised: |
| Void: |

| | | | |
|--|---------|----------------|--------|
| CONNECTING AURARIA TRAFFIC SIGNAL PLAN | | | |
| Designer: | KPM | Structure | |
| Detailer: | KPM | Numbers | |
| Sheet Subset: | TRAFFIC | Subset Sheets: | 2 of 3 |

Project No./Code
 Sheet Number

C:\wip\w\0456331\Connecting_Auraria_Signal_Plans.dwg



CITY AND COUNTY OF DENVER
STATE OF COLORADO



DENVER
THE MILE HIGH CITY

**DEPARTMENT OF TRANSPORTATION &
INFRASTRUCTURE**

**Technical Specifications, Plans/Drawings,
Addendum 1 – Dated June 28, 2022**

Contract Number: 202263315

Connecting Auraria

June 6, 2022

**PLEASE NOTE: Documents listed above are
incorporated by reference and filed with the
Clerk and Recorder. File #: 20220087**