



**DENVER**  
THE MILE HIGH CITY  
JOHN W. HICKENLOOPER  
MAYOR

# CITY AND COUNTY OF DENVER

DEPARTMENT OF GENERAL SERVICES  
**PURCHASING DIVISION**  
www.denvergov.org/purchasing

WELLINGTON E. WEBB  
MUNICIPAL OFFICE BUILDING  
201 WEST COLFAX AVE., DEPT. 304  
DENVER, CO 80202  
PHONE: (720)913-8100  
FAX: (720)913-8101

Date: August 11, 2010

TO: John Burton Public Works  
Charlotte Pitt Public Works

FROM: Melissa Bordwine, Buyer *MB*

**SUBJECT:**

Master Purchase Order Number 0578A0110  
Title: Polyethylene Recycling, Trash & Compost Carts  
Term: August 11, 2010 to August 10, 2011

10-901

Please note the below Master Purchase Order Number; it may be up to 10 characters long and is unique for each vendor. You must use the Master Purchase Order Number in the "Purchasing Auth" field on your Payment Requests.

Master Purchase Order(s) have been issued to the following vendors:

Item No.:	EPP Attribute	Contract Reference ID Number	Vendor ID Number	Successful Bidder's Name and Address
All	RC, RY, TB	0578A0110	0000000274	Rehrig Pacific Company 625 West Mockingbird Lane Dallas, TX 75247 Attn: Jeris Queen Phone: 800-426-9189 Fax: 214-638-7477 jqqueen@rehrigpacific.com

/mmb

**Environmentally Preferred Purchasing Positive Attributes that apply to this proposal.**

AQ	Indoor Air Quality	LH	Less Harmful Content	RC	Recycled Content
AQ-M	Indoor Air Quality - Manufacturer	LV	Low Volatile Organic Compounds	RR	Reconditioned / Remanufactured
AQ-V	Indoor Air Quality - Vendor	LV-M	Low VOC - Manufacturer	RU	Reusability
BB	Bio-Based	LV-V	Low VOC - Vendor	RY	Recyclability
BD	Bio-Degradable	NA	No Attributes	TB	Take-Back
DY	Durability	OA	Other Attributes	WE	Water Efficiency
EE	Energy Efficient	OA-M	Other Attributes - Manufacturer	3-M	Third party certifications - Mfr
EE-M	Energy Efficiency - Manufacturer	OA-V	Other Attributes - Vendor	3-V	Third party certifications - Vendor
EE-V	Energy Efficiency - Vendor	PD	Product Disassembly Potential		

## Master Purchase Order

<b>DO NOT INVOICE TO THIS ADDRESS</b>		Master Purchase Order No.	0578A0110	
<b>City &amp; County of Denver</b>		Date:	July 29, 2010	Revision No.
Purchasing Division		Payment Terms	Net 30	
201 West Colfax Avenue, Dept. 304		Freight Terms	DESTINATION	
Denver, CO 80202		Ship Via	Vendor's Choice	
United States		Buyer:	Melissa Bordwine	
Phone: 720-913-8100 Fax: 720-913-8101		Phone:	720-913-8114	

Vendor: Rehrig Pacific Company      Phone: 800-426-9189      Fax: 214-638-7477

Rehrig Pacific Company  
625 West Mockingbird Lane  
Dallas, TX 75247

Ship To: See Exhibit A

Attn: Jeris Queen, jqueen@rehrigpacific.com

Bill To: City and County of Denver  
Public Works Finance / Administration  
201 West Colfax Avenue, Dept. 611  
Denver, CO 80202

**1. Goods/Services:**

Rehrig Pacific Company, a Corporation in the State of Texas, ("Vendor") shall provide the goods, and any services related thereto, identified and described on attached **Exhibit A**, to the City and County of Denver, a Colorado municipal corporation (the "City"), all in accordance with the terms and conditions of this Master Purchase Order.

**2. Ordering:**

The City shall purchase one or more of the goods/services by issuing a written purchase order(s) or similar appropriate written document ("Order"), each of which will be deemed incorporated into this Agreement for purposes of such Order only.

**3. Pricing:**

The pricing/rates for the goods/services is contained on **Exhibit A** and shall be held firm for the term of this Master Purchase Order.

**4. Extension or Renewal:**

The effective period of this Master Purchase Order shall be one year from date of City signature. It is also a specific provision of this Master Purchase Order that the City and the vendor may mutually agree to renew and continue the contract or agreement consummated under this Master Purchase Order for additional periods of one year at the same prices, terms and conditions. However, no more than four (4) yearly extensions shall be made to the original Master Purchase Order.

**5. Non-Exclusive:**

This Master Purchase Order is non-exclusive. City does not guarantee any minimum purchase other than as provided herein.

**6. Inspection and Acceptance:**

City may inspect all goods/services prior to acceptance. Payment does not constitute acceptance. Vendor shall bear the cost of any inspection/testing that reveal goods/services that are defective or do not meet specifications. City's failure to accept or reject goods/services shall not relieve Vendor from its responsibility for such goods/services that are defective or do not meet specifications nor impose liability on City for such goods/services. If any part of the goods/services are not acceptable to City, City may, in addition to any other rights it may have at law or in equity: (1) make a warranty claim; (2) repair and/or replace the goods or substitute other services at Vendor's expense; or (3) reject and return the goods at Vendor's cost and/or reject the services at Vendor's expense for full credit. Any rejected goods/services are not to be replaced without written authorization from City, and any such replacement shall be on the same terms and conditions contained in this Master Purchase Order. Vendor shall perform all services in accordance with the standard of care exercised by highly competent vendors who perform like or similar services.

**7. Shipping, Taxes and Other Credits and Charges:**

All pricing is F.O.B. destination unless otherwise specified. Shipments must be marked with Vendor's name, the Master Purchase Order number, and contain a delivery or packing slip. Vendor shall not impose any charges for boxing, crating, parcel post, insurance, handling, freight, express or other similar charges or fees. Vendor shall notify City in writing of any price decreases immediately, and City shall receive the benefit thereof on all unshipped items. Vendor shall comply with any additional delivery terms specified herein. Vendor shall be responsible for the cleanup and reporting of any contamination (environmental or otherwise) or spillage resulting from the delivery and/or unloading of goods within twenty-four (24) hours of the contamination or spillage or sooner if required by law. Vendor shall procure all permits and licenses; pay all charges, taxes and fees; and give all notices necessary and incidental to the fulfillment of this Master Purchase Order and all cost thereof have been included in the prices contained herein. City shall not be liable for the payment of taxes, late charges or penalties of any nature, except as required by D.R.M.C. § 20-107, et seq. The price of all goods/services shall reflect all applicable tax exemptions. City's Federal Registration No. is 84-6000580 and its State Registration No. is 98-02890. Vendor shall pay all sales and use taxes levied by City on any tangible personal property built into the goods/services. Vendor shall obtain a Certificate of Exemption from the State of Colorado Department of Revenue prior to the purchase of any materials to be built into the goods/services and provide a copy of the Certificate to City prior to final payment.



## CITY AND COUNTY OF DENVER

DEPARTMENT OF GENERAL SERVICES  
PURCHASING DIVISION  
[www.denvergov.org/purchasing](http://www.denvergov.org/purchasing)

WELLINGTON E. WEBB  
MUNICIPAL BUILDING  
201 WEST COLFAX AVENUE  
DEPT 304  
DENVER, CO 80202  
PHONE: (720) 913-8100  
FAX: (720) 913-8101

Date: August 2, 2010

Rehrig Pacific Company  
625 West Mockingbird Lane  
Dallas, TX 75247

ATTN: Jeris Queen

Re: Master Purchase Order Number: 0578A0110

Dear Mr. Queen,

Attached is a Master Purchase Order (MPO) for materials recently quoted to the City by your company. Material will be ordered on an as needed basis by various City Agencies over the term of the MPO.

If you agree to provide these items to the City & County of Denver according to the stated Scope of Work and in accordance with the Pricing and Terms and Conditions, please make two copies of all documents and provide original signatures on each set. Please return both sets to the City, to my attention at the address listed above.

The Master Purchase Order will be countersigned by the City and a complete original set of documents will be returned to you for your records. If you should have any questions, please feel free to contact me at  
(720) 913-8114.

Sincerely,

Melissa Bordwine  
Associate Buyer

**8. Risk of Loss:**

Vendor shall bear the risk of loss, injury or destruction of goods prior to delivery to City. Loss, injury or destruction shall not release Vendor from any obligation hereunder.

**9. Invoice:**

Each invoice shall include: (i) the Master Purchase Order number; (ii) individual itemization of the goods/services; (iii) per unit price, extended and totaled; (iv) quantity ordered, back ordered and shipped; (v) an invoice number and date; (vi) ordering department's name and "ship to" address; and (vii) agreed upon payment terms set forth herein.

**10. Payment:**

Payment shall be subject to City's Prompt Payment Ordinance D.R.M.C. § 20-107, et-seq. after City accepts the goods/services. Any other provision of this Agreement notwithstanding, in no event shall the City be liable for aggregate payments under this Master Purchase Order in excess of Three Million Dollars (\$3,000,000.00). This Master Purchase Order is valid up to \$499,999.99. The balance is subject to City Council approval. The Vendor acknowledges that any goods/services provided beyond those specifically described in **Exhibit A** are performed at Contractor's risk and without authorization from the City. City's payment obligations hereunder, whether direct or contingent, shall extend only to funds appropriated by the Denver City Council for the purpose of this Master Purchase Order, encumbered by the City after receipt of Vendor's invoice and paid into the Treasury of City. Vendor acknowledges that: (i) City does not by this Master Purchase Order, irrevocably pledge present cash reserves for payments in future fiscal years; and (ii) this Master Purchase Order is not intended to create a multiple-fiscal year direct or indirect debt or financial obligation of City. City may setoff against any payments due to Vendor any claims and/or credits it may have against Vendor under this Master Purchase Order.

**11. Amendments/Changes:**

Only the Manager of General Services or his delegate is authorized to change or amend this Master Purchase Order by a formal written change order. Any change or amendment that would cause the aggregate payable under this Master Purchase Order to exceed the amount appropriated and encumbered for this Master Purchase Order is expressly prohibited and of no effect. Vendor shall verify that the amount appropriated and encumbered is sufficient to cover any increase in cost due to changes or amendments. Goods/services provided without such verification are provided at Vendor's risk. The Vendor has no authority to bind City on any contractual matters.

**12. Warranty:**

Vendor warrants and guarantees to City that all goods furnished under this Master Purchase Order are free from defects in workmanship and materials, are merchantable, and fit for the purposes for which they are to be used. For any goods furnished under this Master Purchase Order which become defective within twelve (12) months (unless otherwise specified) after date of receipt by City, Vendor shall either, at City's election and to City's satisfaction, remedy any and all defects or replace the defective goods at no expense to City within seven (7) days of receipt of the defective goods or accept the defective goods for full credit and payment of any return shipping charges. Vendor shall be fully responsible for any and all warranty work, regardless of third party warranty coverage. Vendor shall furnish additional or replacement parts at the same prices, conditions and specifications delineated herein.

**13. Indemnification/Limitation of Liability:**

Vendor shall indemnify and hold harmless City (including but not limited to its employees, elected and appointed officials, agents and representatives) against any and all losses (including without limitation, loss of use and costs of cover), liability, damage, claims, demands, actions and/or proceedings and all costs and expenses connected therewith (including without limitation attorneys' fees) that arise out of or relate to any claim of infringement of patent, trademark, copyright, trade secret or other intellectual property right related to this Master Purchase Order or that are caused by or the result of any act or omission of Vendor, its agents, suppliers, employees, or representatives. Vendor's obligation shall not apply to any liability or damages which result solely from the negligence of City. City shall not be liable for any consequential, incidental, indirect, special, reliance, or punitive damages or for any lost profits or revenues, regardless of the legal theory under which such liability is asserted. In no event shall City's aggregate liability exceed the agreed upon cost for those goods/services that have been accepted by City under this Master Purchase Order. Notwithstanding anything contained in this Master Purchase Order to the contrary, City in no way limits or waives the rights, immunities and protections provided by C.R.S. § 24-10-101, et seq.

**14. Termination:**

City may terminate this Master Purchase Order, in whole or in part, at any time and for any reason immediately upon written notice to Vendor. In the event of such a termination, City's sole liability shall be limited to payment of the amount due for the goods/services accepted by City. Vendor acknowledges the risks inherent in this termination for convenience and expressly accepts them. Termination by City shall not constitute a waiver of any claims City may have against Vendor.

**15. Interference:**

Vendor shall notify the Director of Purchasing immediately of any condition that may interfere with the performance of Vendor's obligations under this Master Purchase Order and confirm such notification in writing within twenty-four (24) hours. City's failure to respond to any such notice shall in no way act as a waiver of any rights or remedies City may possess.

**16. Venue, Choice of Law and Disputes:**

Venue for all legal actions shall lie in the District Court in and for City and County of Denver, State of Colorado, and shall be governed by the laws of the State of Colorado as well as the Charter and Revised Municipal Code, rules, regulations, Executive

Orders, and fiscal rules of City. All disputes shall be resolved by administrative hearing, pursuant to the procedure established by D.R.M.C. § 56-106. Director of Purchasing shall render the final determination.

**17. Assignment/No Third Party Beneficiary:**

Vendor shall not assign or subcontract any of its rights or obligations under this Master Purchase Order without the written consent of City. In the event City permits an assignment or subcontract, Vendor shall continue to be liable under this Master Purchase Order and any permitted assignee or subcontractor shall be bound by the terms and conditions contained herein. This Master Purchase Order is intended solely for the benefit of City and Vendor with no third party beneficiaries

**18. Notice:**

Notices shall be made by Vendor to the Director of Purchasing and by City to Vendor at the addresses provided herein, in writing sent registered, return receipt requested.

**19. Compliance With Laws:**

Vendor shall observe and comply with all federal, state, county, city and other laws, codes, ordinances, rules, regulations and executive orders related to its performance under this Master Purchase Order. City may immediately terminate this Master Purchase Order, in whole or in part, if Vendor or an employee is convicted, plead nolo contendere, or admits culpability to a criminal offense of bribery, kickbacks, collusive bidding, bid-rigging, antitrust, fraud, undue influence, theft, racketeering, extortion or any offense of a similar nature.

**20. Insurance:**

Vendor shall secure, before delivery of any goods/services, the following insurance covering all operations, goods and services provided to City. Vendor shall keep the required insurance coverage in force at all times during the term of the Purchase Order, or any extension thereof, during any warranty period, and for three (3) years after termination of this Purchase Order. The required insurance shall be underwritten by an insurer licensed to do business in Colorado and rated by A.M. Best Company as "A-VIII" or better. Each policy shall contain a valid provision stating "Should any of the above-described policies be canceled or non-renewed before the expiration date thereof, the issuing company shall send written notice to the Denver Risk Management, 201 West Colfax Avenue, Dept. 1105, Denver, Colorado 80202. Such written notice shall be sent thirty (30) days prior to such cancellation or non-renewal unless due to non-payment of premiums for which notice shall be sent ten (10) days prior." Additionally, Vendor shall provide written notice of cancellation, non-renewal and any reduction in coverage to the address above by certified mail, return receipt requested. If any policy is in excess of a deductible or self-insured retention, City must be notified by Vendor. Vendor shall be responsible for the payment of any deductible or self-insured retention. The insurance coverages specified in this Purchase Order are the minimum requirements, and these requirements do not lessen or limit the liability of Vendor. Vendor shall provide a copy of this Purchase Order to its insurance agent or broker. Vendor may not commence services or work relating to the Purchase Order prior to placement of coverage. Contractor certifies that the attached certificate of insurance attached to the Purchase Order documents, preferably an ACORD certificate, complies with all insurance requirements of this Purchase Order. The City's acceptance of a certificate of insurance or other proof of insurance that does not comply with all insurance requirements set forth in this Purchase Order shall not act as a waiver of Vendor's breach of this Purchase Order or any of the City's rights or remedies under this Agreement. The City's Risk Management Office may require additional proof of insurance, including but not limited to policies and endorsements. Vendor's insurer shall name as Additional Insured to its Commercial General Liability and Business Auto Liability policies the City and County of Denver, its elected and appointed officials, employees and volunteers. Vendor's insurer shall waive subrogation rights against the City. All sub-contractors and sub-consultants (including independent contractors, suppliers or other entities providing goods/services required by this Purchase Order) shall be subject to all of the requirements herein and shall procure and maintain the same coverages required of Vendor. Vendor shall include all such entities as insureds under its policies or shall ensure that they all maintain the required coverages. Vendor shall provide proof of insurance for all such entities upon request by City. For Worker's Compensation Insurance, Vendor shall maintain the coverage as required by statute for each work location and shall maintain Employer's Liability insurance with limits of \$100,000 for each bodily injury occurrence claim, \$100,000 for each bodily injury caused by disease claim, and \$500,000 aggregate for all bodily injuries caused by disease claims. Vendor expressly represents to City, as a material representation upon which City is relying, that none of the Vendor's officers or employees who may be eligible under any statute or law to reject Workers' Compensation Insurance shall effect such rejection during any part of the term of this Purchase Order, and that any such rejections previously effected, have been revoked. Vendor shall maintain Commercial General Liability coverage with limits of \$1,000,000 for each occurrence, \$1,000,000 for each personal and advertising injury claim, \$2,000,000 products and completed operations aggregate, and \$2,000,000 policy aggregate. Vendor shall maintain Business Auto Liability coverage with limits of \$1,000,000 combined single limit applicable to all owned, hired and non-hired vehicles used in performing services under this Purchase Order. For Commercial General Liability coverage, the policy must provide the following: (i) That this Purchase Order is an Insured Contract under the policy; (ii) Defense costs in excess of policy limits; (iii) A severability of interests, separation of insureds or cross liability provision; and (iv) A provision that coverage is non-contributory with other coverage or self-insurance provided by City. For claims-made coverage, the retroactive date must be on or before the first date when any goods or services were provided to City. Vendor must advise the City in the event any general aggregate or other aggregate limits are reduced below the required per occurrence limits. At their own expense, and where such general aggregate or other aggregate limits have been reduced below the required per occurrence limit, the Contractor will procure such per occurrence limits and furnish a new certificate of insurance showing such coverage is in force.

**21. Severability:**

If any provision of this Master Purchase Order, except for the provisions requiring appropriation and encumbering of funds and limiting the total amount payable by City, is held to be invalid, illegal or unenforceable by a court of competent jurisdiction, the validity of the remaining portions or provisions shall not be affected if the intent of City and Vendor can be fulfilled.

**22. Survival:**

All terms and conditions of this Master Purchase Order which by their nature must survive termination/expiration shall so survive. Without limiting the foregoing, Vendor's insurance, warranty and indemnity obligations shall survive for the relevant warranty or statutes of limitation period plus the time necessary to fully resolve any claims, matters or actions begun within that period. Bonds shall survive as long as any warranty period.

**23. No Construction Against Drafting Party:**

No provision of this Master Purchase Order shall be construed against the drafter.

**24. Status of Vendor/Ownership of Work Product:**

Vendor is an independent contractor retained on a contractual basis to perform services for a limited period of time as described in Section 9.1.1E(x) of the Charter of City. Vendor and its employees are not employees or officers of City under Chapter 18 of the D.R.M.C. for any purpose whatsoever. All goods, deliverables, hardware, software, plans, drawings, reports, submittals and all other documents or things furnished to City by Vendor shall become and are the property of City, without restriction.

**25. Records and Audits:**

Vendor shall maintain for three (3) years after final payment hereunder, all pertinent books, documents, papers and records of Vendor involving transactions related to this Master Purchase Order, and City shall have the right to inspect and copy the same.

**26. Remedies/Waiver:**

No remedy specified herein shall limit any other rights and remedies of City at law or in equity. No waiver of any breach shall be construed as a waiver of any other breach.

**27. No Discrimination in Employment:**

Vendor shall not refuse to hire, discharge, promote or demote, or to discriminate in matters of compensation against any person otherwise qualified, solely because of race, color, religion, national origin, gender, age, military status, sexual orientation, marital status, or physical or mental disability; and Vendor shall insert the foregoing provision in any subcontracts hereunder.

**28. Use, Possession or Sale of Alcohol or Drugs:**

Vendor shall cooperate and comply with the provisions of Executive Order 94. Violation may result in City terminating this Master Purchase Order or barring Vendor from City facilities or from participating in City operations.

**29. Conflict of Interest:**

No employee of City shall have any personal or beneficial interest in the goods/services described in this Master Purchase Order; and Vendor shall not hire or contract for services any employee or officer of City which would be in violation of City's Code of Ethics, D.R.M.C. §2-51, et seq. or the Charter §§ 1.2.8, 1.2.9, and 1.2.12.

This Master Purchase Order is acknowledged and agreed to by:

Vendor Name: REHRIG PACIFIC COMPANY  
(Company Name)

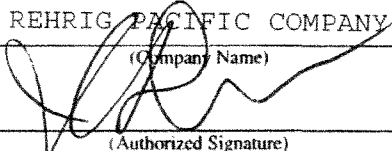
By:   
(Authorized Signature)

Print Name: JAMES L. DREW

Title: C.F.O.

Date: 8/4/2010

City & County of Denver, Purchasing Division

By: 

Print Name: Melissa Bordwine

Title: Associate Buyer

Date: 8-11-10

EXHIBIT "A"

Vendor: Rehrig Pacific Company  
Title: Polyethylene Recycling, Trash & Compost Carts  
Master Purchase Order No.: 0578A0110

---

It is recommended that you use your Master Purchase Order No. – 0578A0110, in all future correspondence, billing, invoicing or other communications.

**1. SPECIFICATIONS AND REQUIREMENTS:**

It is the intent of the City and County of Denver to purchase recycling, trash and/or compost carts that conform to the best practices known to the trade in design, quality of material, and workmanship. Carts shall be standard and interchangeable throughout the entire quantity of carts provided to the City pursuant to award of a particular bid item. Carts shall be new and unused.

**1.a CART DESIGN**

Cart shall be compatible with a fully automated and semi-automated collection system and shall comply with ANSI standards B/G type cart of ANSI Z245.60-1999 and must meet safety standards of ANSI Z245.30-1999.

Carts shall be stable and self-balancing in an upright position, whether loaded or empty and shall maintain stability when returned to the ground after dumping.

Empty carts shall be able to maintain an upright position in sustained or gusting winds up to 25 miles per hour from any direction.

Carts shall be designed to be easily maneuvered when filled to the maximum designed weight on a level or sloped surface.

**1.b CART MATERIAL**

Carts shall be manufactured of first quality virgin polyethylene resin and post-consumer recycled polyethylene resin of equal quality.

Post-consumer recycled resin should make up a minimum of 10% by weight. Vendor shall include a letter(s) certifying the actual percentage of post-consumer and pre-consumer resin used in the containers by weight of the container (that is, % in lid, % in body, % in wheels, etc.) and the sources of that resin.

All virgin resin must be provided by a nationally recognized brand supplier (petrochemical supplier) such as Phillips, Dow, Dupont, BP, Exxon, etc., and must satisfy the manufacturer's original specification for first quality material.

The carts shall be molded of polyethylene resin meeting the requirements of ASTM D4976 "Specifications for Polyethylene Plastics Molding and Extrusion Materials," table PE as follows:

Group	2 Linear	
Class	3 Density 0.940-0.960	ASTM 4883
Grade	3, Flow Rate 1-10 decigrams/minute	ASTM D1238
	Tensile Yield Strength 2600 psi minimum and Elongation at break of 200%	ASTMD638, type IV specimen, 2 inch/minute crosshead rate.
	Secant modulus, 65,000 psi minimum	ASTM D790B, at 2% strain, specimen 0.125"x0.50" with 2" span.

If the cart is rotationally molded, the impact strength of molded specimens at -40C shall exceed 50 ft lbs as tested by ARM (Association of Rotational Molding) impact test using 1/8" thick specimen.

\*A rotationally molded resin may have density as low as 0.935.

If the container is injection molded, the tensile impact strength of molded specimens at -40C shall exceed 120 ft lb/sq in as tested by ASTM D1822.

The cart resin shall contain sufficient ultraviolet absorber additive (ultraviolet stabilizer additive) to provide protection from ultraviolet degradation in the direct sunlight of Denver Colorado for a period of 10 years without brittle fracture in normal use. Resin shall contain a minimum of 1% ultraviolet stabilizer additive.

Resin weight for the 65 gallon cart should be no less than 26 lbs for the base and lid. Resin weight for the 95 gallon carts shall be no less than 34 lbs for the base and the lid. Both weights shall be unassembled carts and shall not include the wheels or other materials required for assembly.

Carts must be made from a material that can be recycled at its end of life. The ability to recycle the cart into another beneficial use product is essential.

**1.c CART COLOR**

The 65 gallon carts shall be purple in color, and shall be a reasonable match to PMS 2755. Alternatively, the City may order green carts, color to match existing carts as closely as possible. The 95 gallon carts shall be black. The City may chose to order either size cart, in purple, green and black. Color must be hot melted into the resin with ½ to 1% color pigment. Dry mixing and or blending of pigment and resin are unacceptable. Color must be uniform within the cart and shall not be streaked in the finished product. Rehrig Pacific Company (Rehrig) shall provide Denver Recycles/Solid Waste Management with color samples prior to production.

The city reserves the right to changes these colors. Should the City need to change the cart color, that change will be requested prior to an order being placed.



**1.d CART DIMENSIONS AND CAPACITY:**

The carts supplied must be of two sizes:

- a. No less than 60 gallon and no greater than 68 gallon
- b. No less than 90 gallon and no greater than 100 gallon

All volumetric capacities are expressed as liquid measures and shall be measured at the full level of the cart body, excluding any additional volume enclosed by the domed lid in the closed position.

The maximum width of the lid and cart shall be:

- a. Twenty-eight (28) inches for 65 gallon cart
- b. Thirty-two (32) inches for the 95 gallon cart

Total height including lid on both sizes shall be no greater than forty-seven (47) inches.

Horizontal section of the carts shall not be square at the place where it is picked up by the clasp arm. The minimum curvature shall be 26%.

Rehrig has submitted drawings, on 8 ½ x 11 paper illustrating the relevant container dimensions.

**1.e CART LIDS:**

Each cart shall be furnished with a lid molded from the same quality material as the cart body.

When open, the lid shall expose the entire circumference of the cart body to allow for clean, smooth dumping.

The lid shall be of such configuration that it shall not warp, bind, slump, or distort.

Lid shall shed water by an overlap not to exceed 1 inch over cart and shall be dome shaped.

The lid shall be designed to remain closed in winds up to 30 miles per hour from any direction. Vendors are required to furnish wind tunnel test information based upon the relevant ANSI testing standard.

The lid shall be attached to the cart without the use of a metal hinge, metal cable, or metal pin. Lids with a living hinge are not acceptable. And the lid and hinge shall be designed to withstand and maintain functionality through the serviceable life of the cart.

The lid shall have the same approximate thickness as the cart base.

The lid shall have space for a photographic education message to be placed on it. The City will provide Rehrig with 4-color photographic artwork that will be no smaller than 4 x 16, or 9 x 14 inches. It is required that this education message be in-molded into the lid and produce a high quality visual image. It is required that the label be photographic quality. The lid shall also contain two (2) arrows, with language to be determined indicating the cart should face this way.

The lid shall open to a minimum of 110 degrees.

The lid and cart must be designed so that a full or empty container will not flip backwards when opening the lid.

**Lf CART BASE:**

The exterior of the cart shall be of textured non-slip finish. It shall be free from sharp corners, edges, points and other structures that could present a hazard or nuisance. Carts shall be adequately designed to prevent slipping through lifting arm when lifted and turned upside down.

The interior surface of the cart shall have a high-gloss finish.

The cart base shall have molded/hot-stamped into it in a prominent location the manufacturer's name, the month and year of manufacture and cart serial number.

Carts shall be hot stamped on up to three sides with messages selected by the City. The City prefers that hot stamped messages on the carts purchased for use in the **trash** collection program have **reflective** hot stamp messages. This applies only to the trash carts. Messages shall incorporate the following information (subject to modification after award). Messages on 95 gallon containers may be slightly different:

- "Please place the container at the designated pick up area by 7:00AM on your day of service. This container and its contents are the property of the City and County of Denver and distributed for the express purpose of holding residential recyclable materials." (Approximate size 6" x 6")
- "Scavenging is prohibited" (Approximate size 6" x 6").
- Denver Recycles Logo, Phone Number and Web Address (Approximate size 12" x 12")

The cart handles and lid hinges must be designed so the cart can be dumped cleanly from any angle.

The cart handle must be designed so that it is attached to the cart without penetrating the surface of the cart body. The cart handle may be part of the hinge. The only exposed portion of the hinge shall be the gripping surface. All other hinge points shall be completely enclosed in a cylinder and molded into the cart. The cart handle must be so designed that if broken it can be replaced to its original condition. Each handle shall have two grasping locations. Handles mounted with screws, bolts or fasteners are unacceptable.

Axle brackets shall be molded into the cart body and shall be positioned in such a manner that they support the outer ends of the axle. They shall be set against the hub of the wheel for maximum support. The cart shall have molded-in "wheel wells" of such size so that the wheels are fully recessed within the bottom width diameter of the container.

The carts shall be designed to regularly receive and dump the following weights:

- 65 gallon cart up to two hundred (200) pounds
- 95 gallon cart up to three hundred (300) pounds

Carts must be stackable in their fully assembled condition, except for the attachment of the wheels. If the wheels are not attached they must accompany each cart and be easy to install.

Wall thickness of the base shall be no less than 0.175 inches average throughout the cart and shall be a minimum of 0.185 inches in critical areas defined as cart bottom, handle and lift mechanisms. Test shall be performed daily during manufacturing with results forwarded to the City prior to shipment.

Carts must come equipped with either a plastic or metal lift bar on the front of the cart to allow use in semi-automated applications. Metal lift bars must be factory installed. Plastic lift bars must be part of the cart mold.

Each cart shall have a foot-hold area on the back of the container to allow for foot placement so as to assist in tilting back the container prior to rolling it.

**1.g CART AXLE AND WHEEL:**

Each cart shall be equipped with an axle and two snap on wheels.

Axle shall be constructed of zinc chromate plated steel or approved equal, and shall be a minimum 5/8 inch in diameter.

Axle shall be located in such a manner that it is not exposed to the inside of the cart and not attached to the cart by any bolts, screws, or rivets.

Wheels shall be no less than 10 inches diameter and approximately 2 inches wide and shall be constructed of first quality grade resin. Capacity of wheels and axle shall be a minimum of two hundred (200) pounds each and four hundred pounds per pair.

**1.h EDUCATION ASSISTANCE**

Rehrig shall support the City and County of Denver's efforts to provide effective education to its residents. Effective education will lead to increased participation in the recycling program, which could result in an increased number of carts purchased.

The ability of Rehrig to provide adequate education on the lid of the cart is essential. Rehrig shall have the ability to in-mold the graphic education message on the lid.

Rehrig shall also provide the City with \$1.00 per cart for the life of this contract to support education efforts. These funds will be made available to the City on July 30th of each year and calculated based on the actual number of carts purchased during the previous year from July 1st through June 30th. These funds will be used by the city to market increased participation in the recycling and composting program.

**1.i AVAILABILITY OF PARTS:**

Replacement parts shall be readily available from the manufacturer or the distributor and must be delivered within three (3) business days of order or notice of warranty defect. Up to 250 extra lids and wheels shall be provided (upon request) annually to the City at no extra charge for replacements and repairs.

**1.j WARRANTY:**

Rehrig shall provide the City with a minimum full, non-prorated, ten year warranty from date of delivery against breakage or material failure (including all hardware) for each container. Container shall be replaced or repaired if failure occurs because of:

1. Cracking, chipping, peeling, or distortion.
2. Lowered ultraviolet resistance to aging in the process of normal operational use. Fading of the plastics will be used as the guide for lowered UV resistance. A color match will be established when colors are finalized at the time of purchase as well as the shade scale. A color degradation of more than 3 shades will be considered unacceptable. For example, if the cart is an exact match to PMS 2755, color degradation to PMS 2725 would be considered unacceptable.
3. Weathering degradation, improper or inadequate materials.

4. Poor material workmanship on the part of the manufacturer.
5. Failure at attachment points for lids, hinges, wheels, or other points of attachments.

Defective carts that are replaced under the warranty provision shall be replaced as complete carts, that is, with lids provided. However, if lids should fail then only the lid shall be replaced. Rehrig agrees to reimburse the City for any cost that may be incurred by the City incidental to the loading; shipping; and recycling of defective carts; lids; and hardware. If vendor fails to remove any defective items at time of delivery of new carts or parts, or upon request, the City may recycle/dispose of the items and charge the contractor for the cost of said recycling/disposal.

In addition to any warranty implied by law, vendor expressly warrants all items to be new, free from defects in design, materials, and workmanship and to be fit and sufficient for their intended purpose. Vendor shall be required to make quarterly warranty inspection visits to the locations specified in item 1.p as needed and warranty replacement must be made within 45 calendar days.

**1.k ORIGINAL MANUFACTURER:**

Rehrig has specified that they are the original manufacturer. Once specified the original manufacturer cannot sub-contract the construction of the carts for the City.

**1.l PRODUCT QUALITY:**

All equipment shall be new, current models. All components must be of current manufacture, no discontinued or out-of-production components. One-of-a-kind or prototypes will not be allowed.

**1.m CART RECYCLING AT END OF LIFE:**

Rehrig shall be required to take back carts that have reached the end of their useful life. Old carts must be diverted from the landfill (disposal) and recycled. The vendor shall be responsible for all costs associated with ensuring these carts are recycled. They shall communicate with the City as to proposed disposition. Landfill daily cover and waste to energy is not an acceptable means of recycling.

**1.n DEFINITIONS:**

**Post-Consumer** is defined as "Material or product that has served its intended use and has been discarded for disposal after passing through the hands of a final user".

**1.o ESTIMATED QUANTITIES:**

Quantities listed are the City and County of Denver's best estimate and do not obligate the Buyer to order or accept more than City and County of Denver's actual requirements during the period of this agreement, as determined by actual needs and availability of appropriated funds. It is expressly understood and agreed that the resulting MPO is to supply the City with its complete actual requirement of the materials specified in this proposal for the contract period.

Orders are usually placed two times per year, however no guarantee is made as to the frequency of orders.

The City reserves the right to place orders for larger quantities up to 25,000 carts per order, should a cart expansion be approved. The City reserves the right to request a spot quote or to perform a formal bid, if such order(s) should be needed.

**1.p F.O.B. POINT:**

All prices quoted at a firm price F.O.B. Denver, Colorado, delivered to one of five (5) possible locations within the City limits to include:

- 5440 Roslyn
- 2013 Osage
- 7301 East Jewell
- 1390 Decatur
- 1271 West Bayaud

**1.q DELIVERY CONSIDERATIONS:**

Deliveries are to be made as soon as possible after orders are placed and are anticipated within no more than a six (6) week period from the date the Vendor receives a PO.

**1.r COOPERATIVE PURCHASING:**

The City and County of Denver encourages and participates in cooperative purchasing endeavors undertaken by or on behalf of other governmental jurisdictions, pursuant to Denver Revised Municipal Code Sec. 20-64.5. To the extent other governmental jurisdictions are legally able to participate in cooperative purchasing endeavors, the City and County of Denver supports such cooperative activities. Further, it is a specific requirement of this proposal or Request for Proposal that pricing offered herein to the City and County of Denver may be offered by the vendor to any other governmental jurisdiction purchasing the same products.

The vendor(s) must deal directly with any governmental agency concerning the placement of purchase orders, freight charges for destinations outside of the Denver Metro area, contractual disputes, invoicing, and payment. The City and County of Denver shall not be liable for any costs, damages incurred by any other entity.

**1.s PALLET CHARGE:**

All pallets supplied shall be non-returnable, no deposit.

**1.t LABORATORY / PROFESSIONAL TESTING:**

In the event materials shipped to the City as outlined herein indicate substandard specifications in a qualitative or quantitative manner, the City reserves the right to have a laboratory, or other appropriate professional test made. If material is found to be deficient, the vendor shall be required to pay all costs of testing. If found to meet specifications, the City shall pay all costs.

Description of the goods, and services related thereto, being purchased and pricing:

Item No.	Description	Manufacturer Offered	Model # (if applicable)	Net Unit Price
1	90 to 100 gallon cart for use in a fully automated system (Est. 2,000 per year) as per specification or approved equal	Rehrig Pacific Company	ROC-95U	\$43.23
Guaranteed Delivery within <u>40</u> Calendar Days after receipt of order.				
2	60 to 68 gallon cart for use in a fully automated system (Est. 12,000 per year) as per specification or approved equal	Rehrig Pacific Company	ROC-65U	\$38.76
Guaranteed Delivery within <u>40</u> Calendar Days after receipt of order.				
3	Cost of Optional REFLECTIVE logo hot stamp, per cart			
4	Cost per Cart to Install RFID Tags in/on carts (NOTE: This is an optional accessory. The City may or may not take advantage of this during the term of the agreement)			

## RESIN MARKET PRICING ADJUSTMENTS

A resin market review and price adjustment will be allowed three (3) times each year, every four (4) months from start date of contract. The most recent "PLASTIC NEWS" Resin Price List, Volume Thermoplastics Section, Column II (Annual Volumes of 2-5 million pounds), Injection GP Pricing will be used as the basis for determining the relevant increase or decrease in quoted Cart Pricing. The most recent PLASTICS NEWS Resin Price List in effect at the time of contract award will become the initial benchmark. These PLASTIC NEWS prices are shown as a range, for example the April 26, 2010 Volume Thermoplastics List shows HDPE, Injection GP, Column II as 92-94 cents/lb. Historically, all pricing on the Volume Thermoplastics Sheet has normally moved in unison per PLASTICS NEWS, so this item has been chosen for comparison. The tri-annual comparison will be made using the high figures in the columns. The percentage increase or decrease will be applied to the "Current Resin Cost" you submitted with your proposal in Section C.5 (Proposal Pricing Item No. 5). The difference between the resulting cents per pound figure and the quoted figure from Section C.5 will then be multiplied by the resin weight of the carts you supply. If the comparison results in a 5% annual increase, you will only be allowed to increase the resin component of your cart pricing by 5%, you will not be allowed to increase the total cost of the carts by 5%. If the comparison results in a 5% decrease, you will be required to reduce the resin component of your cart pricing by 5%. This new, cents per pound resin calculation will become the basis for the pricing review after the first 4 month period and the same formula will be used in subsequent periods for the life of the contract.

### EXAMPLE:

Cart Offered = 90 Gallon with 34# of resin  
Quoted Price = \$50.00  
Current Resin Cost (Proposal Item # 5) = \$.90/lb.  
Resin Component of Total Price = \$30.60 (\$.90/lb x 34#)

Benchmark PLASTIC NEWS Volume Thermoplastics List, HDPE Injection GP, Column II high value at time of contract award = \$.90/LB  
PLASTIC NEWS Volume Thermoplastics List, HDPE Injection GP, Column II high value from most recent price list at four month anniversary = \$.98/LB

Increase = 8.16%

$\$.90$  (Original Resin Cost) x 8.16 Increase (Divide by .918) = .9803/LB. This figure will be rounded up or down to whole cents, so in this instance the new benchmark price would be \$.98/LB

$\$.98/\text{LB} \times 34\# = \$33.32$  Resin Component to Total Price  
 $\$33.32 - \$30.60 = \$2.72$  Resin Price Increase

Originally Quoted Cart Price =  $\$50.00 + \$2.72 = \$52.72$  Cart Price for 2<sup>nd</sup> 4 month period of the Contract

**VENDOR QUESTIONS AND REQUIREMENTS:**

Rehrig's response to the following questions are included in Attachment A and are hereby incorporated into this MPO.

1. The vendor shall support the City and County of Denver's efforts to provide effective education to its residents. Effective education will lead to increased participation in the recycling program, which could result in an increased number of carts purchased. To assist with education, the vendor shall share with the City printed resources, such as brochures, that may be adapted to educate Denver residents on the effective use of the cart. Please discuss your past experience with municipal education programs involving implementation of automated recycling, trash and/or compost programs.
2. If your company is currently involved in a program that requires cart recycling at end of life (Section B.1.n), please identify the municipality involved and discuss your current methods for complying with this requirement.
3. Describe what efforts your company currently supports for Environmental Stewardship, including such areas as manufacturing, third party certifications, public education, etc.
1. Define the typical quantity for a production run. The City will make every effort to order in production run quantities, but makes no guarantee of this.
5. Detail the maximum number of carts that may result in your inability to meet the contract deadline of 6 weeks from order to delivery.
6. Describe your company's ability to incorporate RFID tags in some or all of the City's trash, recycling and/or compost carts. Discuss each of the following:
  - Current technology available
  - your experience using the technology
  - how it works in the field
  - any testing your company has conducted
  - costs of and sources for RFID tag readers, software requirements
  - other information about your products and processes.





### **B.3 VENDOR QUESTIONS AND REQUIREMENTS:**

**Question 1.** The vendor shall support the City and County of Denver's efforts to provide effective education to its residents. Effective education will lead to increased participation in the recycling program, which could result in an increased number of carts purchased. To assist with education, the vendor shall share with the City printed resources, such as brochures, that may be adapted to educate Denver residents on the effective use of the cart. Please discuss your past experience with municipal education programs involving implementation of automated recycling, trash and/or compost programs.

#### **In Mold Labels:**

We have helped several cities design an In Mold Label to have manufactured with the lid of the cart. The flat section of our lid allows us to work with a very large IML size up to 9.5" x 14.5". We also can work with a label up to 6"x16" depending on the city's desire. We believe the larger the label size, the more you can educate on the lid in multiple colors. This allows plenty of room to educate in multiple languages as well.

#### **Educational Program**

Rehrig Pacific is committed to working in conjunction with City of Denver in developing and introducing educational assistance information that may be helpful to the residents within your community.

Our nation-wide sales force is trained and educated to speak at community events to help educate the residents during the program's implementation. Rehrig Pacific is prepared to assist City of Denver in educating its residents on topics ranging from "how to use your container" to "the benefits of recycling and waste diversion".



**Rehrig can assist in the development and implementation of your program, outlining your community's specific informational objectives.**

#### **Educational Information:**

- Benefits of automated & semi-automated collection
- Assistance with local media/open forums to develop program acceptance
- Introduction of program to the residents (see enclosed brochure)
- Brochure outlining "safe use" and/or "maintenance of container"
- Community Newsletters
- Physical demonstration of cart collection





---

**B.3 VENDOR QUESTIONS AND REQUIREMENTS**

**Question 2.** If your company is currently involved in a program that requires cart recycling at end of life (Section B.1.n), please identify the municipality involved and discuss your current methods for complying with this requirement.

Since Rehrig Pacific was very fortunate to supply the City of Denver Roll Out Carts since 2005, we have actively been recycling the carts from the City of Denver for five years. We currently use Denver Metro company by the name of M-J Enterprises. Jerimiah Wickham owns the company and he has agreed to go to the City of Denver's site and collect the damaged roll out carts and haul them away at no cost to the city. His company grinds the carts up and resells the material without it going to the landfill. If we were the successful bidder, we would continue using this method in the future.

If for some reason M-J Enterprises could not complete this task, Rehrig Pacific will find a comparable company or individual to complete these tasks to ensure that the carts do not go to the landfill. We ask that the city can store up to 250 broken carts before we have M-J Enterprises or other company come pick them up. This method has been very successful in the past and Rehrig Pacific will withhold these standards.

We provide these exact or similar services to the City of Waco, Texas. In Los Angeles, California we have a complete site that cleans and grinds carts into flake material. That material is taken to our plant in Los Angeles and made into new carts. Do to the volume of that project, exceeding 3 million carts, we were able to justify setting up complete operations with the City of Los Angeles.



---

### B.3 VENDOR QUESTIONS AND REQUIREMENTS

**Question 3.** Describe what efforts your company currently supports for Environmental Stewardship, including such areas as manufacturing, third party certifications, public education, etc.

Rehrig Pacific has been in business for nearly 100 years. We actively started a fluent recycling program in 1937 when we would take back large milk crates and install new bottoms in them. The move to plastic milk crates came in the late 1960s and the plastic beverage carrier came in the early 1970s. During any manufacturing process, some scrap can be produced. So Rehrig installed grinding equipment and were able to reuse that scrap material back into new crates. Then we worked out deals with our customers to take back their old crates and put that material in new crates. Every year, Rehrig recycles millions of crates from Coke, Pepsi, HEB, Deans, and several other large companies.

#### **Recycling In-House Material**

Today, all seven of our manufacturing facilities are outfitted with grinding systems, many with pelletizers to cleanse the plastic even further. This allows us to recycle all in-house material let alone attempt to bring in several other streams of recycled materials from the outside.

#### **Recycling HDPE Material**

In our Atlanta facility we purchase Truckloads of Fractional Melt HDPE (Milk Jug Material). We purchase this from Waste Management Recycle America, send it to a 3rd party to grind and clean the bails of material. Once we have clean material, we then ship it to our facility. We buy several truckloads (100,000s of pounds) of this material each month and continuously expand on this material stream in other parts of the country. We run this material in excess of 20% in all of our Roll Out carts. Depending on the color of the carts, we can exceed 35% PCR in our carts and more in our lids. We can do this in black carts like we have produced for the City of Denver.

#### **Multiple Plants to alleviate freight distance to all customers**

Rehrig is the only cart manufacturer in the U.S. that has five plants producing carts. This has enabled us to ship shorter distances to all of our customers. When tractor trailers have to travel shorter distances, it is a benefit to the environment because less fuel is used, in hand less emissions.

#### **Proximity to Denver, CO**

In the previous contract with the City of Denver, Rehrig Pacific produced most of the carts in our De Soto, Kansas facility. De Soto, KS is a one-day shipment into the City of Denver. This proximity to Denver allows us to time shipments and avoid over night stays in the truck for truck drivers, which can consume more fuel.



---

**B.3 VENDOR QUESTIONS AND REQUIREMENTS****Question 3 (continued)****Public Education**

Rehrig Pacific Company is committed to getting involved in the educational outreach to the communities as the program is implemented. Our nation-wide sale force is trained and education to speak at community events to help educate the residents during the program's implementation. Rehrig Pacific is prepared to assist the City and County of Denver in educating its residents on various topic ranging from "how to use your container " to "the benefits of containerized collection and waste diversion". we can also provide the residents of Denver with a wealth of information regarding similar automated collection programs by sharing facts and experiences taken from our existing municipal customer base.

In addition, Rehrig Pacific Company can provide brochures (see enclosed) that can be customized to outline Denver's specific collection program. The brochure can also include direction instructing the resident on how to use their new container. Rehrig Pacific Company's marketing team is open to suggestion on how we would be of assistance to make this a mutually beneficial partnership.

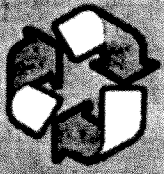

# Where do your recyclables go?



From your home

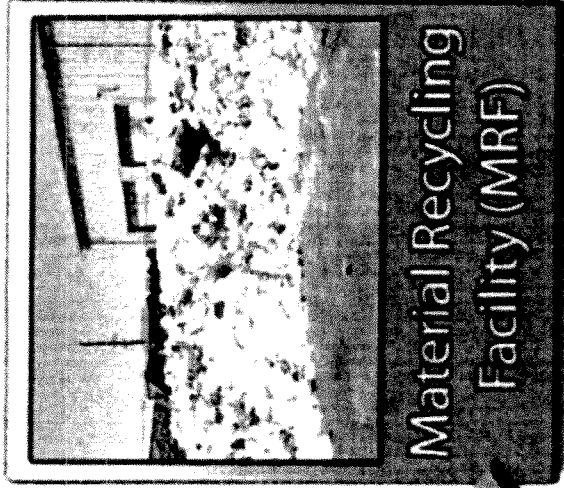

Material Recycling Facility (MRF)



Sorted Plastic in a Bail





# Where do your recyclables go?

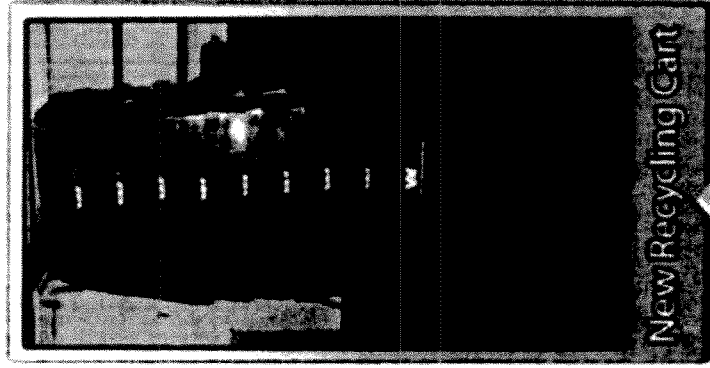
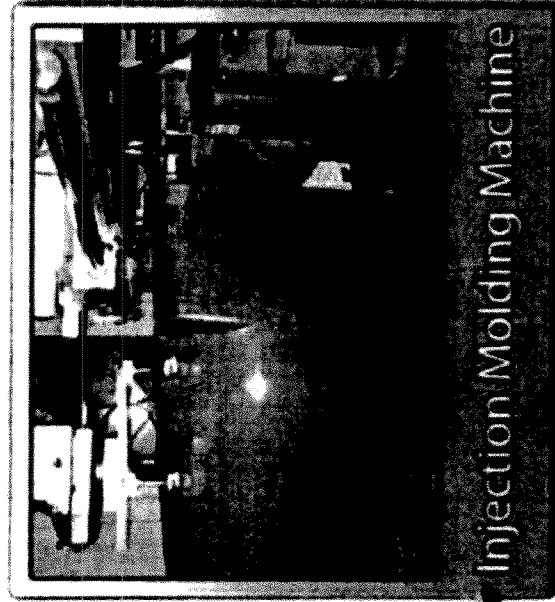
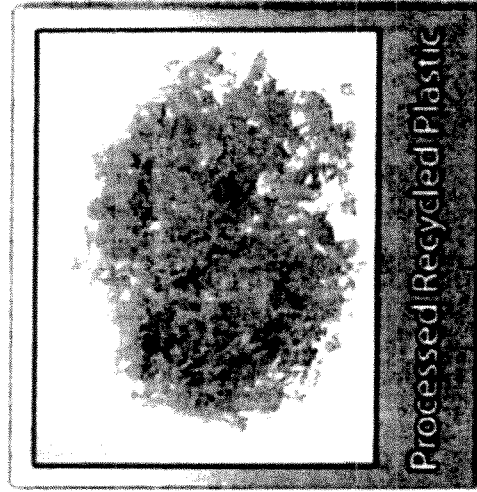

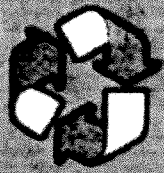

Where do your recyclables go?



Recycled Milk Jugs

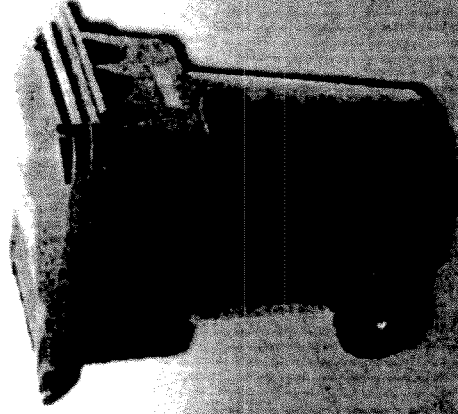

New Recycling Cart





---

### B.3 VENDOR QUESTIONS AND REQUIREMENTS

**Question 4.** Define the typical quantity for a production run. The City will make every effort to order in production run quantities, but makes no guarantee of this.

**Cart Capacity**

Rehrig Pacific is in a unique position with having five separate plants with roll out cart capability. By using the Injection Molding process we can run up to 1000 carts per day on each cart mold. Depending on the size and quantity of the order, we can apply more than one mold to the production of the order.

To be most efficient, ideally we would ship in full load quantities. Our full load quantities are:

95 Gallon Carts - 486  
65 Gallon Carts – 648  
35 Gallon Carts – 1,080

However, we can mix and match loads if necessary. For instance, if the City of Denver ordered a half load of 65 gallon carts and a half load of 95 gallon carts, we'd look to run those orders in a facility that was running both molds. We'd combine the two orders to ship in one truck to Denver saving fuel and shipping costs.

For orders between 5,000 and 15,000 carts of one size, we typically would run that order on one mold and get 1,000 carts per day. This is just over two loads per day. For orders over 15,000 we could look into running a 2<sup>nd</sup> mold and ship four loads per day into Denver. Typically orders over 15,000 would have to have several teams to deliver the carts to the residents. Therefore every quantity is unique depending on resources. By having multiple plants, Rehrig has several options to fulfill the City of Denver orders.





---

**B.3 VENDOR QUESTIONS AND REQUIREMENTS**

**Question 5.** Detail the maximum number of carts that may result in your inability to meet the contract deadline of 6 weeks from order to delivery.

**Order Fulfillment**

With the exception of holidays, Rehrig runs each of our manufacturing facilities 24 hours/day, seven days/week. With five manufacturing facilities, and multiple cart producing machines in our plants, we have several options. Since we produce all week long, six weeks is 42 production days. Realistically, give a couple days to prepare for the order, we could run orders up to 80,000 in six weeks. This is applying only two cart molds to the order, however we could align more cart molds to fulfill a larger order.

Typically, orders over 10,000, let alone 80,000, take a lot of preparation work on both the cart vendor and the municipal. We have our own Rehrig employed teams that could assemble and deliver the carts to the residents of Denver. For any very large program, it would be best to have a lot of time for planning to ensure a complete and painless delivery.

Therefore, with minimal planning, we can commit to run an order up to 80,000 carts in six weeks. We are capable of running more; however, we want to maintain a great level of service for all of our customers.



### B.3 VENDOR QUESTIONS AND REQUIREMENTS

**Question 6.** Describe your company's ability to incorporate RFID tags in some or all of the City's

trash, recycling and/or compost carts. Discuss each of the following:

- Current technology available
- your experience using the technology
- how it works in the field
- any testing your company has conducted
- costs of and sources for RFID tag readers, software requirements
- other information about your products and processes.

#### Environmental Services Group Introduction

The Rehrig Pacific Company has been servicing the Solid Waste and Recycling Industry for over 22 years. Throughout this time we have constantly tried to answer the needs of our customers by providing innovative and creative solutions for containerized refuse and recycling programs. Therefore, given its obvious connection to our core business of refuse and recycling container manufacturing, we have decided to invest the necessary capital and resources to create the Rehrig Pacific Environmental Services Group. The Environmental Services Group provides the Solid Waste and Recycling Industry with a variety of innovative service solutions that can be implemented by any Municipality, Government Entity or Waste Hauler. Essentially, Rehrig Pacific Company has evolved into a complete solutions provider for your entire container and associated service needs. Rehrig Pacific is excited about the potential opportunity to partner with the City of Denver to provide these service offerings as part of your recycling program.

#### *RFID Technology Integration for Carts*

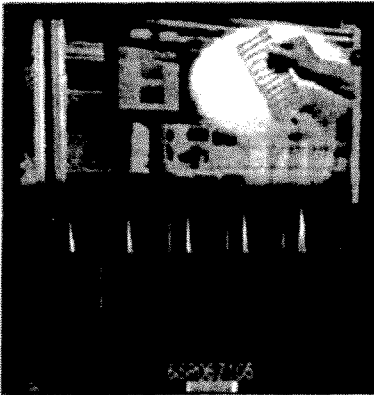

Rehrig Pacific Company has been integrating RFID and Bar Code technology into our rollout carts for over two years. To date we have produced over 1.5 million carts with RFID and Bar Code technology. All five of Rehrig Pacific's cart-producing-plants have the necessary equipment to install either Ultra High Frequency or Low Frequency RFID tags and associate the RFID tag values with the containers serial number/bar code at the work cell.

At the manufacturing facility Rehrig Pacific brands a bar code/serial number and places an RFID tag to each cart produced. Rehrig Pacific secures the UHF RFID tag in the lid pin, which is then inserted into the cart handle. This provides two layers of protection for the RFID tag from such factors like inclement weather and the rigors of cart collections. At the manufacturing work cell, Rehrig Pacific makes an association between the RFID tag and bar code /serial number. The advantage of associating the RFID tag and cart serial number is to be able to identify the RFID





tag value that is imbedded into the cart by reading the serial number; this eliminates the need for an expensive RFID handheld scanner to handle work orders or container movement in the future. This information can provide the foundation for a variety of service offerings such as recycling participation tracking, which can be used to tailor recycling programs and educate those who do not participate or to provide incentives to those who do participate. The end result is increased program participation, which means higher disposal cost savings to the City.

**Advantages of Purchasing Rehrig Pacific RFID & Bar Code Integrated Carts:**

- Our UHF tags are protected in the cart body and are not exposed to the outside elements such as weather or the rigorous environments posed by our industry
- RFID Tags and Bar Codes are all tested at our facilities before the carts ship
  - This ensures that the technology functions properly for your program
- The production data collected from our manufacturing facility is stored on our (C.A.R.T.S.) server, which provides a foundation for tracking these cart assets in the future and providing multiple service offerings for our customers

***Cart Retrofit Services with Address Association***

In addition to applying RFID technology to our carts at the manufacturing facility, Rehrig Pacific is also able to retrofit existing containers – those already in the field – with RFID tags. The RFID tag is applied in the field and then associated to either the cart's serial number or an applied bar code. This association allows us to create a database where each residential address is linked to a specific cart with a unique RFID tag and serial number. The database provides a foundation for future service offerings, just as if you were to buy new carts with RFID technology.

Rehrig Pacific Company would follow detailed route lists that must be provided by the City of Denver two weeks prior to the retrofit start date. Rehrig Pacific will upload the detailed distribution lists into our Cart Asset Recovery Tracking System (C.A.R.T.S.) and print out bar-coded retrofit lists for our crews to follow. It is very important to have accurate maps and distribution lists to help minimize program delays.



Bar Code scanning / serial number recording/ RFID Tag Fitting will be performed by crew members and will take place on the routes as the containers are being served on collection day. Each resident will have a corresponding bar code / serial number/ RFID Value on/in their cart and we will associate this information with each household address. At the end of each service





day the data that has been stored in each handheld device will be uploaded to our C.A.R.T.S. system. This information is then compiled to provide detailed service and inventory reports to the City of Denver the day following each retrofit day. Essentially, the C.A.R.T.S. system allows the City of Denver to follow delivery progress on a daily basis, which is extremely beneficial to help the City of Denver answer cart delivery questions during the retrofit.

### Cart Retrofit Tracking Data Flow

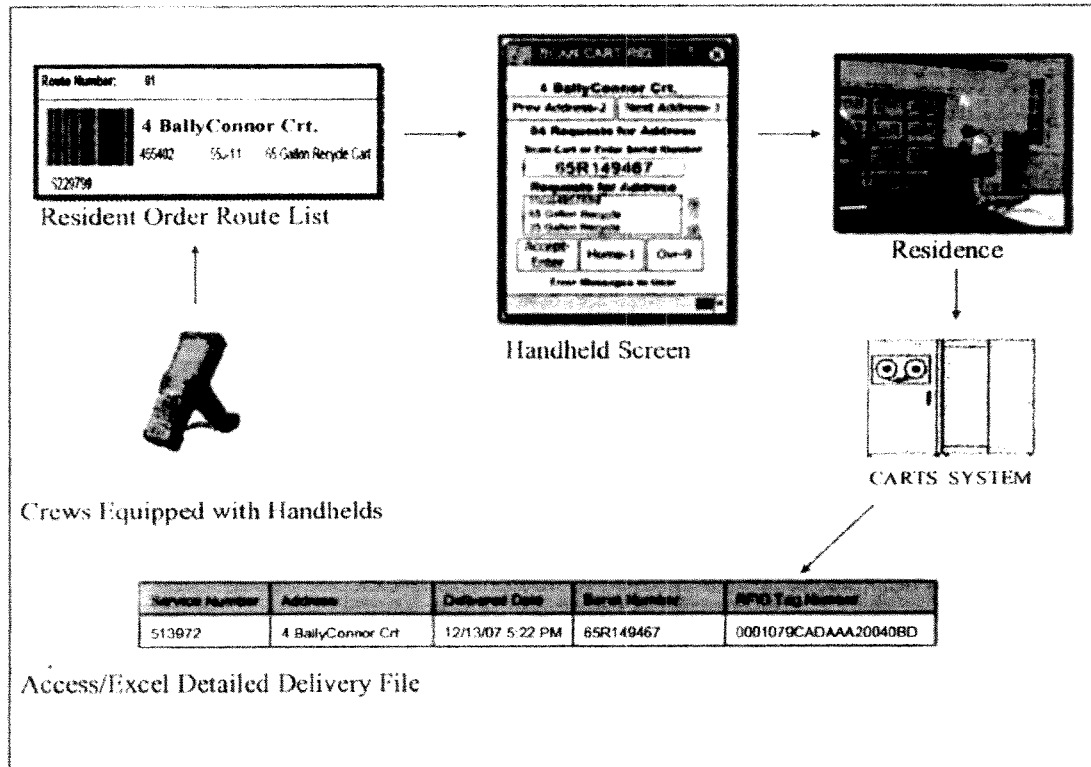

By electronically recording and associated each cart, we are also able to track exceptions during the Retrofit process effectively providing you with an **accurate route audit**. Through the use of the hand held scanner we are able to report new houses and add them to the database "on the fly" in the field, report Vacant houses, wrong addresses, business, etc. Exception codes are completely customizable for each program. (See Snapshot Assembly & Distribution Summary Report Below) This sophisticated method of delivery will ensure that the City is providing the best, most accurate service to your customers as possible.





Snapshot Cart RetroFit Summary Report Below:



**Delivery Summary Report**

**Resolution: Business**

Delivery Date	100	300	600	900	1200	1500	1800	2100	2400
12-17-2009	0	0	0	0	0	0	0	0	3
12-18-2009	0	0	0	0	0	0	0	0	1
01-08-2010	0	0	0	0	0	0	0	0	1
<b>Sub Total:</b>	<b>0</b>	<b>0</b>	<b>0</b>	<b>0</b>	<b>0</b>	<b>0</b>	<b>0</b>	<b>0</b>	<b>5</b>

**Resolution: Vacant**

Delivery Date	100	300	600	900	1200	1500	1800	2100	2400
12-12-2009	0	0	0	0	0	0	0	0	1
12-30-2009	0	0	0	0	0	0	0	0	1
01-02-2010	0	0	0	0	0	0	0	0	1
<b>Sub Total:</b>	<b>0</b>	<b>0</b>	<b>0</b>	<b>0</b>	<b>0</b>	<b>0</b>	<b>0</b>	<b>0</b>	<b>3</b>

**Resolution: Request Fulfilled**

Delivery Date	100	300	600	900	1200	1500	1800	2100	2400
12-10-2009	0	0	0	245	0	0	0	0	0
12-11-2009	0	0	0	1016	0	0	0	0	0
12-12-2009	0	0	0	738	0	0	0	0	0
12-14-2009	0	0	0	577	0	0	0	0	0
12-16-2009	0	0	0	724	0	0	0	0	0
12-17-2009	0	0	0	789	0	0	0	0	0
12-18-2009	0	0	0	226	0	0	0	0	0
12-28-2009	0	0	0	944	0	0	0	0	0
12-29-2009	0	0	0	1430	0	0	0	0	0
12-30-2009	0	0	0	1457	0	0	0	0	0
12-31-2009	0	0	0	1693	0	0	0	0	0
01-02-2010	0	0	0	1254	0	0	0	0	0
01-04-2010	0	0	0	1459	0	0	0	0	0
01-05-2010	0	0	0	753	0	0	0	0	0
01-06-2010	0	0	0	924	0	0	0	0	0
<b>Sub Total:</b>	<b>0</b>	<b>0</b>	<b>0</b>	<b>14228</b>	<b>0</b>	<b>0</b>	<b>0</b>	<b>0</b>	<b>0</b>
<b>Sub Total:</b>	<b>0</b>	<b>0</b>	<b>0</b>	<b>0</b>	<b>0</b>	<b>0</b>	<b>0</b>	<b>0</b>	<b>0</b>
<b>Grand Total:</b>	<b>0</b>	<b>0</b>	<b>0</b>	<b>14228</b>	<b>0</b>	<b>0</b>	<b>0</b>	<b>0</b>	<b>0</b>



Snapshot Cart Distribution /Inventory Report by Detail Below:

RPL		Distribution Detail Delivery Report									
Rehrig Pacific		Cart Date: 10/25/2008									
		End Date: 11/16/2008									
Delivery Date	Route Number	Service Number	Street Number	Street Suffix	Street Name	Unit Number	Unit Type	Panel ID	Serial Number	RFID	
Residential - Requested Pallets											
	Web-SE	1062963	668		Midway St SE		95R	41	95R001401	3000000000 148293083	
	Web-SE	1062979	654		Midway St SE		95R	41	95R001403	3000000000 148293089	
	Web-SE	1062977	646		Midway St SE		95R	41	95R001438	3000000000 148293096	
	Web-SE	1062975	640		Midway St SE		95R	41	95R001402	3000000000 148293091	
	Web-SE	1062973	634		Midway St SE		95R	41	95R001351	3000000000 148293122	
	Web-SE	1062971	626		Midway St SE		95R	41	95R001400	3000000000 148292963	
	Web-SE	1062969	622		Midway St SE		95R	41	95R001358	3000000000 148293034	
	Web-SE	1062967	616		Midway St SE		95R	41	95R001357	3000000000 148293372	
	Web-SE	1062965	610		Midway St SE		95R	41	95R001359	3000000000 148293081	
	Web-SE	1079785	2966		Forest Park Rd SE		95R	41	95R001356	3000000000 148293404	
	Web-SE	1079787	2973		Forest Park Rd SE		95R	41	95R001358	3000000000 148293086	
	Web-SE	1079789	2987		Forest Park Rd SE		95R	41	95R001358	3000000000 148293491	
	Web-SE	1079791	2996		Forest Park Rd SE		95R	41	95R001354	3000000000 148294498	
	Web-SE	1079794	3003		Forest Park Rd SE		95R	41	95R001398	3000000000 148293104	
	Web-SE	1079796	3015		Forest Park Rd SE		95R	41	95R001397	3000000000 148293094	
	Web-SE	1079798	3039		Forest Park Rd SE		95R	41	95R001396	3000000000 148293715	
	Web-SE	1079803	3075		Forest Park Rd SE		95R	41	95R001367	3000000000 148293171	
	Web-SE	1079805	3087		Forest Park Rd SE		95R	41	95R001336	3000000000 148293484	
	Web-SE	1079807	3099		Forest Park Rd SE		95R	41	95R001334	3000000000 148293019	
	Web-SE	1079811	3121		Forest Park Rd SE		95R	41	95R001313	3000000000 148293886	
	Web-SE	1079813	3131		Forest Park Rd SE		95R	41	95R001333	3000000000 148293658	
	Web-SE	1079815	3151		Forest Park Rd SE		95R	41	95R001312	3000000000 148293281	

**C.A.R.T.S. Overview**

Throughout this proposal you have seen the word C.A.R.T.S., which stands for Cart Asset Recovery Tracking System, and is referring to Rehrig Pacific's proprietary web-based asset and inventory management software that can be customized to the specific needs and requirements of our customers. Once your address database is uploaded to the C.A.R.T.S. system, the Environmental Services Group (ESG) can help implement a variety of services, including:

- **Delivery & Inventory Management:** track the progress of container shipments and manage inventory levels at your distribution centers.
- **Container Distribution:** record container deliveries in real time by using handheld scanners in conjunction with the C.A.R.T.S. system.
- **Monitor Container Distribution Progress:** generate daily distribution reports that include household address, container serial #, RFID tag #, type, size, date and time of delivery.
- **Ongoing Container Maintenance:** integrate maintenance work order systems with C.A.R.T.S. to track container inventories, repairs, and work flow.





- **Collection Data Tracking Services:** integrate RFID technology and data collection equipment on trucks to accurately track container collection data and manage the data in C.A.R.T.S. with various reports available to our customers.

Customized reports can be generated from the C.A.R.T.S. database to provide specific reports for your operation. Examples of these reports will be included in the applicable sections of this proposal.

#### **C.A.R.T.S.**

C.A.R.T.S. (Cart Asset Recovery Tracking System) provides users with a real time snapshot of cart inventory at all locations in their supply chain. Using C.A.R.T.S. to manage work orders and inventory does not require our customers to change any of their current billing systems or customer service databases; it just provides an opportunity to eliminate some of the administrative work associated with cart maintenance. This tracking system is designed to accurately automate the process of transmitting work orders, provide real time visibility, and detailed reports as it relates to a city's cart maintenance program. In the event Rehrig Pacific manufactures your carts and performs the A&D, we will have created a database in our C.A.R.T.S. database for a cart maintenance program.

#### **C.A.R.T.S. Standard Operating Procedure**

Resident phone calls for cart maintenance will be fielded by City of Denver customer service people. RPL will work with Denver's IT department to determine the most efficient and accurate means of transferring the information received from the resident phone call to creating and completing the work order in the field. The city has the option of entering work orders directly into Rehrig's web-based C.A.R.T.S. system. However, if a city chooses to maintain this information in their current customer service database, we can create a batch file of all work orders to be exported from the city's database to Rehrig's C.A.R.T.S. system. If a city chooses the batch file option, RPL proposes that a Text File be generated and sent (e-mailed) to RPL's administrative people on a scheduled basis. RPL will provide a written export specification (sample row below) that will transfer data into the C.A.R.T.S. system.

Account #	Work Order #	Address	Date Created	Problem Code	Status
000987998	123456	123 W. Main Street	8/17/08	Wheel	Pending

The maintenance crew receives this request and generates a route to fulfill all work order requests within the required time frame. Once they reach the residence and complete the work, the information will be recorded and entered into C.A.R.T.S. at the end of the work day. RPL will then generate a file with the completed requests and send it to the appropriate city representatives. The file will contain the actual work completed, time stamp, cart details, and any other pertinent information that the city sees fit (sample row below). This information can be provided in a format that is acceptable by the city in order to automatically update your customer service database.



Account #	Work Order #	Address	Date Serviced	Resolution Code	Status
000987998	123456	123 W. Main Street	8/19/08	Repl-Wheel	Complete

**C.A.R.T.S. Reporting**

By utilizing C.A.R.T.S., designated city personnel will have web access to view all of the work orders that have been submitted and completed for each program. Customized reports can be generated for any type of work function, and are available online, in a PDF format, or Excel Export Format. Customized reports can be developed based on the exact needs of the City of Denver.

Sample Closed Work Order Report:

W.O. No.	Quantity	Service Address	Service Description	Requested Date	Completed Date	Qty. Delivered	Resolution Description	W.O. Price
<b>Route: 28</b>								
WOP00010000	1	124 S 4TH ST	New Account Medium 15Gallon/Recycle Cart	6/17/2009	6/18/2009	1	Delivered Bin of Cart	70000000
WOP00010001	1	115 MOUNTAIN DR	New Account Large 45Gallon/Recycle Cart	6/17/2009	6/17/2009	1	Delivered Bin of Cart	61800000
WOP00010002	1	1205 KENNEDY DR	Size Swap to Medium 15Gallon/Recycle Cart	6/18/2009	6/18/2009	0	Reschedule, Cartline Job	
WOP00010003	1	8112 DELVIEW RD UNIT AA	New Account Large 45Gallon/Recycle Cart	6/18/2009	6/18/2009	1	Delivered Bin of Cart	61800721
WOP00010004	2	17178 WOODBURN RD	Size Swap to Extra Large 75Gallon/Recycle Cart	6/18/2009	6/18/2009	0	Cart to Size Swap/Exchange	10000000
WOP00010005	1	278 E 1ST ST	New Account Medium 15Gallon/Recycle Cart	6/18/2009	6/18/2009	1	Delivered Bin of Cart	11800000
WOP00010006	1	200 W CANTON ST	New Account Medium 15Gallon/Recycle Cart	6/18/2009	6/18/2009	1	Delivered Bin of Cart	11800000
WOP00010007	1	1111 W DEWEES DR	Size Swap to Extra Large 75Gallon/Recycle Cart	6/18/2009	6/18/2009	0	Cart to Size Swap/Exchange	10000722
WOP00010008	2	3436 LINDSEY DR	New Account Large 45Gallon/Recycle Cart	6/18/2009	6/18/2009	2	Delivered Bin of Cart	60000723
WOP00010009	1	1001 EIGHTH RD	New Account Large 45Gallon/Recycle Cart	6/18/2009	6/18/2009	2	Delivered Bin of Cart	61800204
WOP00010010	1	1001 EIGHTH RD	New Account Large 45Gallon/Recycle Cart	6/18/2009	6/18/2009	2	Delivered Bin of Cart	60000000
WOP00010011	1	100 EIGHTH RD	New Account Large 45Gallon/Recycle Cart	6/18/2009	6/18/2009	1	Delivered Bin of Cart	61800200
WOP00010012	1	1100 EIGHTH RD	New Account Large 45Gallon/Recycle Cart	6/18/2009	6/18/2009	2	Delivered Bin of Cart	60000000
WOP00010013	1	1100 EIGHTH RD	New Account Large 45Gallon/Recycle Cart	6/18/2009	6/18/2009	1	Delivered Bin of Cart	61800200
WOP00010014	1	1100 EIGHTH RD	New Account Large 45Gallon/Recycle Cart	6/18/2009	6/18/2009	2	Delivered Bin of Cart	60000000

**Cart Inventories**

C.A.R.T.S. has the capability of managing the City's cart inventory levels – by cart size and by location, as indicated in the following customized report. This can be expanded upon to include multiple sites or styles of containers within the City for ease of inventory swaps and cross utilization between service areas or types of collection allowing for greater asset utilization without additional purchases being necessitated.





Sample Inventory Summary Report Below:

		<b>Inventory Summary</b> 2/26/2008 3:29 PM	
Location Type	Item Type	Status	Quantity
<b>Distribution</b>			
	35 Gallon Recycle Cart	At Residence	0
	35 Gallon Recycle Cart	In Stock	12,058
	35 Gallon Recycle Cart	In Transit	1
	35 Gallon Recycle Cart	Newly Manufactured	0
	65 Gallon Recycle Cart	At Residence	0
	65 Gallon Recycle Cart	In Stock	51,174
	65 Gallon Recycle Cart	In Transit	1,288
	65 Gallon Recycle Cart	Newly Manufactured	0
	95 Gallon Recycle Cart	At Residence	0
	95 Gallon Recycle Cart	In Stock	4,388
	95 Gallon Recycle Cart	In Transit	0
Location Type Subtotal:			<b>69,409</b>
<b>MFG Plant</b>			
	35 Gallon Recycle Cart	Newly Manufactured	4,854
	65 Gallon Garbage Cart	Newly Manufactured	3,360
	65 Gallon Recycle Cart	Newly Manufactured	5,125
	95 Gallon Recycle Cart	Newly Manufactured	11
Location Type Subtotal:			<b>13,350</b>
<b>Multi Family Home</b>			
	35 Gallon Recycle Cart	At Residence	814
	65 Gallon Recycle Cart	At Residence	5,787
	95 Gallon Recycle Cart	At Residence	739
Location Type Subtotal:			<b>7,120</b>
<b>Single Family Home</b>			
	35 Gallon Recycle Cart	At Residence	6,470
	65 Gallon Recycle Cart	At Residence	73,003
	95 Gallon Recycle Cart	At Residence	15,538
Location Type Subtotal:			<b>95,011</b>
<b>Report Total:</b>			<b>184,890</b>

*C.A.R.T.S. Software Cost Proposal*

**C.A.R.T.S. software subscription**

**\$1350 (plus \$150 for each RPC Supplied Hand Held Device)/month with Customized Collection Data Reporting**

- Delivery management
- Manages cart inventories
- Cart maintenance tracking
- Collection Data Tracking Reports

Included in the cost above  
 Included in the cost above  
 Included in the cost above  
 Included in the cost above





---

### *Truck Retrofits for Collection Data Tracking*

In addition to the previous information submitted regarding the RFID technology, Rehrig Pacific is also submitting the following proposal for RFID Technology for the Trucks Systems. Rehrig Pacific is excited for the opportunity to be the full service provider for the City of Denver. We are more than capable of handling the following: manufacturing of your containers, implementing RFID tags into the containers, performing Cart Maintenance on all of the City's containers, and implementing the RFID technology on the trucks to track participation, manage inventories, and offer multiple reporting capabilities.

**Due to the very customizable nature of this technology we have not included the final pricing regarding this technology. Instead, we have included "not to exceed" numbers in order to inform the City that Rehrig Pacific has the ability to perform all of these services and is willing to negotiate with the City as to your intentions and needs. As always, extremely basic systems exist and so do very complex ones. These numbers are intended to provide budgetary information and a place from which to work. We include them here as well should the City wish to bundle these services under one provider and one Bid. That said, it is our goal to ensure that the City attains the solution that it feels is most beneficial to its needs. Therefore we want to make clear that our system, software, and technology is compatible with ANY system currently on the market today.**

Based on our experience in the market place, Rehrig Pacific has formed a partnership with a company whom we believe to be the most reliable and comprehensive supplier of truck mounted RFID reading systems. To date, Rehrig Pacific (and its partner Sonrai Systems) has provided many customers with sophisticated collection data tracking solutions for the Solid Waste and Recycling Industry on hundreds of collection vehicles. We are able to install RFID tracking systems on any type of collection truck available, including: commercial front and rear load, currotto cans, semi-automated rear load, semi-automated side load, and/or fully automated collection vehicles.

The advantage of our system is that any type of container can be tracked to verify participation in recycling programs (IE: curbside recycling bins being collected manually along with carts being collected in fully or semi-automated programs) and they do not require the collection haulers to interact with computers or change any of their current collection methods. In addition, the systems have the ability to proactively track lost or stolen containers, determine residential or commercial participation/collection verification and thus efficiently manage routes, collection programs, pay as you throw programs and provide the foundation for incentive based recycling programs.

These sophisticated tracking systems are also compatible with Rehrig's C.A.R.T.S. system, which is used to maintain an accurate account database and provided online collection data tracking reports. The data is simply tracked during collection and stored on an Intermec IF61 mobile reader and then automatically sent to Rehrig Pacific's server via a wireless internet connection at the end of each collection day. Reports that outline the number of households participating in recycling per truck would be available via the web through the C.A.R.T.S. system along with cart inventories and locations by each residential address.



Included is a brief summary of the Rehrig Pacific UHF RFID tracking solution that is available to the City of Denver for your tracking of collection data in your service area. This summary includes equipment, installation, performance and data management services that could be provided by Rehrig Pacific.

#### Sample Data Collection Equipment:

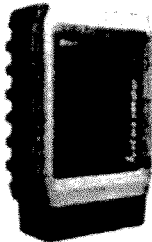

- **Intermec IF61 RFID Smart Reader** - The IF61 smart RFID reader is capable of embedding enterprise-class edge servers and software in lieu of requiring an on-truck computer. Advanced network services built into the IF61 greatly facilitates enterprise architects in configuring a highly secure, scalable, and reliable RFID infrastructure. In order for RFID readers to do more than simply read and act as a data conduit, they need processing speed and ample memory. With the powerful combination of an Intel Celeron M 600MHz processor and up to 1 GB of optional

memory, the Intermec IF61 Enterprise Reader is the smartest RFID reader available, capable of running complex RFID applications, delivering faster processing and localized intelligence and eliminating the need for a separate industrial PC. By hosting various applications the IF61 can filter, store and manipulate information from RFID tags and send it to a server in the required format, while monitoring external sensors and controlling audible and visual indicators. For example, the IF61 can be programmed to store a day's worth of recycling collections and drive a device to issue a visual and/or audible signal to let the operator know the reader is operating correctly.

- **IA33D Antenna Cell** - With its unique, mostly metal design, the Intermec Antenna Cell is an RFID antenna specifically developed for truck installations where shock and vibration can far exceed the specifications of antennas designed for fixed RFID reader applications.

**Frequency Range IA33D:** 865 – 870 MHz

**Gain** 6.0 dBi

**Maximum Input Power** 10 Watts

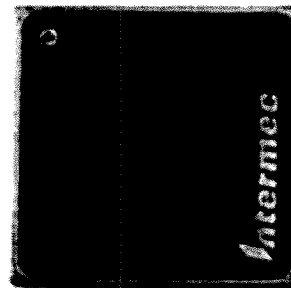



**Installation:** Rehrig Pacific Company's partners Sonrai Systems would provide all labor, tools and equipment required to install RFID readers, antennas and on board computers. This includes all connections, cabling and testing. See Manufacturers Warranty Attached for Installation Guarantees.

**Performance:** The system would be configured to read the RFID tags on all containers targeted for data collection. Data collected would include the container ID being collected, the date and time of the collection event and the latitude and longitude of the truck at the time the container was collected.

**Data Management:** The readers are associated with the truck number they are installed on. At the end of the collection day when a truck is returned to the collection haulers yard or at the local recycling MRF the reader will initiate a wireless connection. Once the truck reaches the wireless hot spot, a download of the RFID tag reads and other pertinent data that has been recorded during collection will be transferred to Rehrig Pacific's C.A.R.T.S. system for the purpose of generating reports and analysis through the secure web based software.

Sample Participation Reports Below:

RPL Rehrig Pacific Company		Howard County, MD Tipping Participation					
						Start Date: 6/15/2009	
						End Date: 6/16/2009	
						ZIP Code: ALL	
						Route: Monday	
<p>1 Sample of participation: 405 54.04%</p>							
15900001	000108464707941526000000	5409 ABEL ST	5409	ABEL ST	Garage	MD	21075 6/15/2009 11:17:38 AM
15900057	000108464707941526000780	5413 ABEL ST	5413	ABEL ST	Garage	MD	21075 6/15/2009 11:17:23 AM
15900091	000108464707941526000048	5417 ABEL ST	5417	ABEL ST	Garage	MD	21075 6/15/2009 11:17:49 AM
15900237	000108464707941526000953	5411 ABEL ST	5411	ABEL ST	Garage	MD	21075 6/15/2009 11:18:05 AM
15900266	000108464707941526000054	5448 ABEL ST	5448	ABEL ST	Garage	MD	21075 6/15/2009 11:18:29 AM
15900263	000108464707941526000485	5452 ABEL ST	5452	ABEL ST	Garage	MD	21075 6/15/2009 11:18:26 AM
15900174	000108464707941526000002	5453 ABEL ST	5453	ABEL ST	Garage	MD	21075 6/15/2009 11:18:14 AM
15900078	000108464707941526000244	5454 ABEL ST	5454	ABEL ST	Garage	MD	21075 6/15/2009 11:19:41 AM
15900001	000108464707941526000001	5472 ABEL ST	5472	ABEL ST	Garage	MD	21075 6/15/2009 11:20:41 AM
15900070	000108464707941526000300	5476 ABEL ST	5476	ABEL ST	Garage	MD	21075 6/15/2009 11:20:29 AM
15900128	000108464707941526000000	5484 ABEL ST	5484	ABEL ST	Garage	MD	21075 6/15/2009 11:20:47 AM
15900030	000108464707941526000027	5485 ABEL ST	5485	ABEL ST	Garage	MD	21075 6/15/2009 11:20:02 AM
15900129	000108464707941526000048	5486 ABEL ST	5486	ABEL ST	Garage	MD	21075 6/15/2009 11:20:14 AM
15900070	000108464707941526000300	5492 ABEL ST	5492	ABEL ST	Garage	MD	21075 6/15/2009 11:20:35 AM
15900082	000108464707941526000004	5493 ABEL ST	5493	ABEL ST	Garage	MD	21075 6/15/2009 11:20:37 AM
15900080	000108464707941526000248	5494 ABEL ST	5494	ABEL ST	Garage	MD	21075 6/15/2009 11:20:14 AM
15900081	000108464707941526000000	5501 ABEL ST	5501	ABEL ST	Garage	MD	21075 6/15/2009 11:20:04 AM
15900078	000108464707941526000300	5505 ABEL ST	5505	ABEL ST	Garage	MD	21075 6/15/2009 11:20:09 AM



RPL Rehrig Pacific Company		Week-Month Non-Participation		
		Start Date: 10/19/2009		
		Week Span: 1 Week(s)		
Non-Participation Summary				
Day	Count	Total	Percentage	
Monday	385	876	43.9%	
Tuesday	574	1063	53.0%	
Wednesday	715	1098	65.8%	
Thursday	415	694	59.8%	
Friday	550	1147	48.7%	
Non-Participants				
ID	Location	Count	Day	
6410	ABEL ST	21075	Monday	
6415	ABEL ST	21075	Monday	
6421	ABEL ST	21075	Monday	
6425	ABEL ST	21075	Monday	
6440	ABEL ST	21075	Monday	

*Truck System (RFID Technology) Cost Proposal*

**Truck RFID System Retrofit Price**

- Qty: 8 trucks (6 and 2 back ups) *not to exceed \$16,500.00*
- Type: TBD
- IF61 solution with 1 hopper antenna
- WiFi data download
- Installation of equipment
- 3 year IF61 warranty coverage See Complete Copy of Warranty Attached

\*Note: System above does not include a Contamination Button. Adding a Contamination Button with

Contamination Capture System Logic is an \$800.00 option added to base system price.

**Sonrai Optional WiFi Implementation *not to exceed \$5,500.00 Installed***

**WiFi Wireless Network Requirements**

Includes all the appropriate hardware and services (limited to one router and/or one wireless access point) to bring up the wireless network at the customer location to support the communications of data from Sonrai Systems truck systems through an internet connection back to the Sonrai Systems/Rehrig hosted data center. Must have confirmation that a dedicated network connection is installed, live and available at customer location prior to Sonrai Truck systems installation.

Internet access must be free of firewall and/or VPN connection requirements,

**OR**





Have remote customer network access to a local PC workstation on customer network with appropriate remote access software (PCAnywhere, Go to My PC, etc.)

**OR**

Have access to local customer network at site with VPN Tunnel established between the local site and Sonrai Systems location.

**COPY of SONRAI TRUCK SYSTEM WARRANTY**

**MANUFACTURER'S WARRANTY**

Sonrai Systems, Inc. ("SONRAI") warrants equipment of its own manufacture and/or provided as part of Sonrai Event Capture Systems to be free from defects in materials and installation workmanship under normal use and service, to the original purchaser only, subject to the conditions outlined below.

**This warranty is the only warranty applicable to components manufactured and/or provided by SONRAI and is expressly in lieu of all other warranties, expressed or implied including implied warranty of merchantability or fitness for a particular purpose.**

This warranty shall not apply to any failure or damage incurred through neglect, lack of maintenance, misuse, accidents, improper installation (if by others), re-designing of assemblies or through any other cause beyond the control of SONRAI, or any other incidental or consequential damage incurred at any time. This warranty shall not apply if the equipment has been modified or adjusted from the factory original specifications. This warranty shall be expressly limited to the repair or replacement of defective parts, as stated above, all other damage and claims, statutory or otherwise, being hereby waived by the purchaser. SONRAI limits its warranty to parts and accessories supplied by it and installed in compliance with the prevailing industry standard. If any sample or model was shown to or provided by Buyer, such sample or model merely illustrates the general type and quality of Goods and is not to be construed as warranty that said Goods will conform to the sample or model. Descriptions or illustrations contained in SONRAI'S catalogues, price lists, or advertising are intended for general information only. SONRAI makes no warranty that Buyer holds or will hold the Goods free of the claim of any third person that may arise from alleged patent or trademark infringement. No agent, employee or representative of SONRAI has any authority to bind SONRAI to any affirmation, representation or warranty concerning the Goods, except an officer of SONRAI who agrees to do so in writing. SONRAI neither assumes nor authorizes any other person to assume for it any other liability in connection with the sale of its equipment. If applicable, it is the responsibility of SONRAI'S customer to install the equipment in conformity with all applicable ANSI Z245 safety requirements and all applicable OSHA requirements.

**36 MONTH Sonrai RFID Reader/Computing Appliance PARTS WARRANTY SCHEDULE**

**FIRST THROUGH THIRTY-SIXTH MONTH:** SONRAI will furnish without charge, F.O.B. its plant, an approved **Sonrai RFID Reader/Computing Appliance** part which proves to be defective in normal use and service during the period. SONRAI will support the customer's replacement labor via phone/internet support and/or written service manual instructions to install/replace any **Sonrai RFID Reader/Computing Appliance** hardware component. If





required by the customer, SONRAI will perform the required RFID hardware replacement on-site for a scheduled allowable labor rate, travel labor charges and incurred expenses on a per service/warranty incident. Additional required customer's labor charges, if authorized, to install such parts will be allowed in accordance with scheduled allowable labor rates or flat rate, authorized by SONRAI prior to performance of said labor. Wear items and abuse are not covered under this warranty policy. Travel labor charges are limited to (3) three hours maximum per service call. This warranty shall not apply to any failure or damage incurred through neglect, lack of maintenance, misuse, accidents, improper installation (if by others), re-designing of assemblies or through any other cause beyond the control of SONRAI. All defective hardware parts will be repaired or replaced and shipped within 5 working days of receipt of defective hardware.

**12 MONTH PARTS WARRANTY SCHEDULE**  
**Excluding Sonrai RFID Reader/Computing Appliance**

**FIRST THROUGH TWELVE MONTHS:** SONRAI will furnish without charge, F.O.B. its plant, an approved part to replace any part or product of its' supply or manufacture which proves to be defective in normal use and service during the period. SONRAI will support the customer's replacement labor via phone/internet support and/or written service manual instructions to install/replace any Sonrai provided hardware component. If required by the customer, SONRAI will perform the required RFID hardware replacement on-site for a scheduled allowable labor rate, travel labor charges and incurred expenses on a per service/warranty incident. Additional required customer's labor charges, if authorized, to install such parts will be allowed in accordance with scheduled allowable labor rates or flat rate, authorized by SONRAI prior to performance of said labor. Wear items and abuse are not covered under this warranty policy. Travel labor charges are limited to (3) three hours maximum per service call. This warranty shall not apply to any failure or damage incurred through neglect, lack of maintenance, misuse, accidents, improper installation (if by others), re-designing of assemblies or through any other cause beyond the control of SONRAI. All defective hardware parts will be repaired or replaced and shipped within 5 working days of receipt of defective hardware.

*Experience and References*

***Experience in Similar Programs (That include RFID Enabled Carts, Truck Systems and ongoing Maintenance Services Utilizing our C.A.R.T.S. system)***

**Toronto** - The City of Toronto implemented a city wide cart program for garbage and recycling collection in December 2007, and Rehrig Pacific produced and delivered over one million carts to 550,000 households over an 18-month period. As carts rolled off the manufacturing line they were tracked via C.A.R.T.S. from the time of manufacture until delivery to a resident. In addition, Rehrig Pacific started a ten year Cart maintenance program simultaneous to the cart rollout and work orders were generated through the City's proprietary customer service system and integrated into CARTS via a batch file data transfer. Due to exchanges and swap outs, the volume of work orders generated was 300-500 per day. An additional ten to fifteen crews utilizing Rehrig issued hand held mobile computers were enlisted to handle all work orders. Each cart is tracked individually at each stop in the supply chain as carts move from address to storage and back to other addresses. The C.A.R.T.S. system manages the status of each cart





---

whether it is new or out of service and drives the invoicing for new carts purchases. Rehrig is now in year two of the ten-year maintenance contract with Toronto.

***Toronto Contact Information: Kevin Vibert at 416-397-0203***

**Frederick County, MD** - In 2008, Rehrig Pacific produced and delivered over 75,000 containers for Frederick County, MD as a part of their enhanced curbside single stream recycling program. The container sizes included 95, 65, and 35 gallon carts as well as 18-gallon recycling bins. Each cart was equipped with an embedded ultrahigh frequency RFID tag at the Rehrig Pacific manufacturing plant during production. Rehrig's assembly and distribution subcontractors used our proprietary C.A.R.T.S. software in conjunction with handheld scanners to associate each container's RFID tag value and serial number to a specific address during the delivery process. Allied Waste, the County's collection hauler, is utilizing (13) thirteen collection vehicles equipped with Rehrig/Sonrai's RFID tracking systems for purposes of tracking resident participation in the recycling program. The systems monitor residential recycling participation by reading each container's RFID tag as they are collected at the curb and at the end of each collection day the data is transferred from the truck's system to Rehrig Pacific servers via wireless hot spot. The collection participation data is automatically imported into Rehrig Pacific's C.A.R.T.S. system for purpose of developing customized participation reports that the County and Allied can view online daily. In addition, Allied Waste has subscribed to Rehrig Pacific's C.A.R.T.S. system in order to track all inventory levels and work order management as part of the container maintenance program associated with this deal.

***Frederick County Contact Info: Dawn Adams at 301-600-7403***

**City of Medicine Hat, Alberta** - In August of 2009, Rehrig Pacific produced and delivered over 25,000 carts for KC Environmental and the City of Medicine Hat, Alberta. The container sizes included 65, and 35 gallons and each cart was equipped with an embedded ultrahigh frequency RFID tag at the Rehrig Pacific manufacturing plant during production. Rehrig's assembly and distribution subcontractors (KC Environmental) used our proprietary C.A.R.T.S. software in conjunction with handheld scanners to associate each container's RFID tag value and serial number to a specific address during the delivery process. In addition, KC Environmental has subscribed to Rehrig's C.A.R.T.S. system for cart maintenance services. Each cart is tracked individually at each stop in the supply chain as carts move from address to storage and back to other addresses. The C.A.R.T.S. system manages the status of each cart whether it is new or out of service. Currently, the City of Medicine Hat is in the process of working with Rehrig Pacific to take the next step in their program and introduce collection data tracking services with RFID tracking systems on their collection trucks.

***Medicine Hat Contact Info: Aaron Hills (KC Environmental) at 780-488-7926***

**City of Fall River, MA**- In September of 2009, Rehrig Pacific started their first phase delivery of over 5,000 carts to the City of Fall River, MA. The container sizes included 95, 65, gallon carts, which were all equipped with an embedded ultrahigh frequency RFID tag at the Rehrig Pacific manufacturing plant during production. Rehrig's internal assembly and distribution crews used our proprietary C.A.R.T.S. software in conjunction with handheld scanners to associate each container's RFID tag value and serial number to a specific address during the delivery process. In addition, the City of Fall River has hired Rehrig Pacific to perform cart maintenance services





---

as part of this contract. All of the work that is associated with this cart maintenance program is tracked through Rehrig's C.A.R.T.S. system.

***Fall River Contact Info: Betsey Westell at 508-324-2580***

**City of Kingsville, TX-** In October of 2009, Rehrig Pacific produced and delivered 8,000 95 gallon containers to the City of Kingsville, TX for their curbside refuse program. Each cart was equipped with an embedded ultrahigh frequency RFID tag at the Rehrig Pacific manufacturing plant during production. Rehrig's internal assembly and distribution crews used our proprietary C.A.R.T.S. software in conjunction with handheld scanners to associate each container's RFID tag value and serial number to a specific address during the delivery process. The City is also utilizing (5) five collection vehicles equipped with Rehrig/Sonrai's RFID tracking systems for purposes of tracking resident participation in the refuse program. The systems monitor residential refuse participation by reading each container's RFID tag as they are collected at the curb and at the end of each collection day the data is transferred from the truck's system to Rehrig Pacific servers via wireless hot spot. The collection participation data is automatically imported into Rehrig Pacific's C.A.R.T.S. system for purpose of developing customized participation reports that the City can view online daily. In addition, the City has subscribed to Rehrig Pacific's C.A.R.T.S. software in order to manage all of their cart maintenance work orders and to maintain an accurate database and inventory levels.

***Kingsville Contact Info: Diane Leubert at 361-595-8090***

**City of Atlanta, GA-** In November of 2009, Rehrig Pacific produced and delivered 10,000 95 gallon containers for the City of Atlanta for an Incentive Based Recycling program that was designed and implemented by Rehrig Pacific. Each cart was equipped with an embedded ultrahigh frequency and a low frequency RFID tag at the Rehrig Pacific manufacturing plant during production. Rehrig's internal assembly and distribution crew used our proprietary C.A.R.T.S. software in conjunction with handheld scanners to associate each container's RFID tag value and serial number to a specific address during the delivery process. The City is also utilizing (5) collection vehicles equipped with RFID tracking systems for purposes of tracking resident participation in the recycling program. The systems monitor residential recycling participation by reading each container's RFID tag as they are collected at the curb and at the end of each collection day the data is transferred from the truck's system to Rehrig Pacific and RecycleBank (Rehrig's Subcontractor) servers via wireless hot spot. The collection participation data is automatically imported into Rehrig Pacific's C.A.R.T.S. system for purpose of developing customized participation reports that the City can view online daily and it is also submitted to RecycleBank in order for them to provide the residents with rewards as part of the program. In addition, Rehrig Pacific is also providing cart maintenance services as part of this contract and all work orders are managed through our C.A.R.T.S. system.

***Atlanta Contact Info: Mary Harrington at 404-865-8540***

**RecycleBank -** For almost two years, the Rehrig Pacific Environmental Services Group has been performing two separate Cart Maintenance programs for RecycleBank in the New England and Mid Atlantic areas. The New England Area includes the Cities of Everett, MA, Revere, MA and Hartford, CT. The Mid Atlantic Region encompasses 19 different communities in NJ,



---

Eastern PA and Delaware. These maintenance contracts are different in nature as we are responsible for maintaining the performance of RFID tags on each container as well as providing standard cart maintenance services. Due to Rehrig Pacific's advancements in RFID technology, we have the experience, systems and infrastructure in place to efficiently manage the technical piece of these programs. For RecycleBank, the performance of each tag is extremely important for the success of their program, as it is used to determine customer's recycling participation and for rewarding each participant accordingly. RecycleBank trusts Rehrig Pacific with this task because of our experience in working with RFID technology and the advancements we have made in the market.

***RecycleBank Contact Info: Beth Kean-Waddell at 215-779-9603***

**Flood Brothers** - The Flood Brothers have over 15 trucks equipped with Sonrai System's RFID solution on every type of collection truck that is used in our industry. This equipment has been in place for more than two years and it has proven out to be such a significant return on investment that Flood Brother's are planning to retrofit all of the commercial collection vehicles in their fleet with the type of equipment.

***Flood Brothers Contact Info: Chris Flood at 630-878-8141***



Request for Proposal No. RECYCLE\_CARTS\_\_0578A  
Polyethylene Recycling, Trash & Compost Carts

**SECTION D: DECLARATION OF DATA FOR CARTS OFFERED IN SECTION B.1**

In the following Declaration of Data you are required to respond to each Specification. If specific values are requested, you must provide the required information. For other specifications, if what you are offering is exactly as specified, show "As Specified". If your carts vary at all from the listed specification, you must provide details on the variance. If the space provided is not adequate, provide a separate sheet and reference the Specification Number with your explanation.

Click **HERE** to link to the Declaration of Data WORD Table.

Enter your information in the columns provided on the WORD Table and save it on your media.  
**DO NOT ALTER THE CITY'S DOCUMENTS IN ANY WAY.**

The following pages are a hard copy of the Declaration of Data. Replace these pages with your completed WORD Table.

You may also access the WORD Table by going to [www.denvergov.org/purchasing](http://www.denvergov.org/purchasing) click on the Icon Bid Attachments and find the corresponding attachment for this proposal.

SPECIFICATION	CARTS OFFERED
Manufacturing process (rotational cross-linked, rotational linear, injection, etc.)	Mfg. Process Offered: <u>Injection Molded</u>
2. Body Unit: quality of virgin and recycled materials. Please attached resin supplier reference and specification.	As Specified-see Material specs section
3. Body Unit: Percentage of Pre-Consumer Waste content, Percentage of Post-Consumer Waste content and Percentage of Virgin content	As Specified-see recycled content doc in materials section
4. Body capable of returning to near original shape after bending by impact or heat.	As Specified
5. Wall thickness (minimum 0.175", with critical points 0.185")	Wall thickness provided is: 0.175 wall and 0.185 critical wear
6. Color 65 gallon = purple (PMS 2755), green and black 95 gallon = black and purple	As Specified

Bid Forms



Request for Proposal No. RECYCLE\_CARTS\_\_0578A  
 Polyethylene Recycling, Trash & Compost Carts

Section D

SPECIFICATION	CARTS OFFERED
7. Ultraviolet stabilizer additive % (minimum 1%)	Ultraviolet stabilized additive <u>2</u> %
8. Color pigment % (minimum 1/2 to 1%)	Color Pigment <u>2</u> %
9. No dry mixing or blending of pigment	As Specified-see attached material information
10. Total number of parts	95U / 65U (plastic bar) 7 parts (metal bar) 8 parts
11. Total resin weight of each component and total assembled weight for the 60-68 gallon cart that you are offering.	Body: <u>23</u> LBS. (Resin Weight) Lid: <u>3.5</u> LBS. (Resin Weight) Wheels: <u>2.62</u> LBS. (Resin Weight) Fully assembled weight: <u>32.12</u> LBS.
12. Total resin weight of each component and total assembled weight for the 90-100 gallon cart that you are offering.	Body: <u>29.3</u> LBS. (Resin Weight) Lid: <u>4.91</u> LBS. (Resin Weight) Wheels: <u>2.62</u> LBS. (Resin Weight) Fully assembled weight: <u>39.83</u> LBS.
13. Dimensions: Width of cart and lid, Overall Height	Width of Cart and Lid 60-68gallon: <u>26.70</u> inches Width of Cart and Lid 90-100 gallon: <u>28.50</u> inches
14. Horizontal section: curvature at pickup point please specify %.	Curvature at pickup point = <u>min 26</u> %
15. Actual capacity of the Base (ONLY) in U.S. Gallons	Capacity of the Base ONLY on your 60-68 gal. Cart = <u>66.25</u> gal. Capacity of the Base ONLY on your 90-100gal. Cart = <u>95.0</u> gal.





Request for Proposal No. RECYCLE\_CARTS\_\_0578A  
Polyethylene Recycling, Trash & Compost Carts

SECTION D

SPECIFICATION	CARTS OFFERED
16. Total Base & Lid capacity in US Gallons	Total Capacity-Base Plus Lid on your 60-68 gal. Cart = <u>5.0</u> gal.  Total Capacity-Base Plus Lid on your 90-100gal. Cart = <u>6.7</u> gal.
17. Maximum Weight Capacity 60-68 gallons (minimum 200 lbs) 90- 100 gallons (minimum 300 lbs)	Weight capacity of your proposed 60-68 gallon cart: <u>231.9</u> Lbs.  Weight capacity of your proposed 90-100 gallon cart: <u>332.5</u> Lbs.
18. Lid constructed of same materials and manufacturing process as the cart base	As Specified
19. Body Unit: Percentage of Pre-Consumer Waste content, Percentage of Post-Consumer Waste content and Percentage of Virgin content	As Specified-see recycled content doc
20. Open lid exposes entire circumference of cart body allowing clean, smooth dumping	As Specified
21. Lid will not warp, bind, slump, or distort	As Specified
22. Lid will shed water by overlap of up to 1-inch over cart and shall be dome shaped	As Specified
23. Lid attached to cart without metal hinge, metal cable, or metal pin. No living hinge	As Specified
24. Lid thickness same as cart base	The minimum lid thickness is 0.140. This same lid has been used for over 125,000 units supplied to Denver since 2005.

Bid Form



Request for Proposal No. RECYCLE CARTS 0578A  
Polyethylene Recycling, Trash & Compost Carts

SPECIFICATION	CARTS OFFERED
25. Lid shall have two arrows with language to be determined molded into it indicating direction to be placed	As Specified
26. Photographic, in-molded education information to be placed on the lid. Minimum 8 1/2 x 11 inches. Four-color artwork to be provided by the city.	As Specified
27. Lid to open minimum of 110°	As Specified
26. Lid shall remain closed in 25-mph winds and gust from any direction. Provide wind tunnel tests if available.	As Specified-Tests Attached
27. Manufacturer's name and month and year of manufacture and cart serial number molded in.	As Specified
28. Cart handle and hinges designed so cart can be dumped cleanly from any angle	As Specified
29. Cart handle attached without penetrating surface of the body	As Specified
30. Only exposed portion of the hinge shall be the gripping surface. All other hinge points completely enclosed in cylinder and molded into the cart.	As Specified
31. Handle replaceable	Covered under 10 yr warranty No-it is molded as part of container Lid and hinge pins are.
32. Interior surface shall have high gloss finish.	As Specified



Request for Proposal No. RECYCLE\_CARTS\_\_0578A  
Polyethylene Recycling, Trash & Compost Carts

SPECIFICATION	CARTS OFFERED
33. Exterior surface shall be non-slip	As Specified
34. Axle brackets molded into body and positioned to support outer ends of axle and against hub	As Specified
35. Wheel wells molded in for wheels to be fully recessed within the bottom width diameter of container.	As Specified
36. Snap on wheels	As Specified
37. Axle - zinc chromate plated steel or approved equal	Axle Provided: As Specified
38. Axle minimum 5/8" diameter	Axle Diameter: 3/4 inch diameter
39. Axle not exposed to inside of cart	As Specified
40. Axle not attached by bolts, screws or rivets	As Specified
41. Wheels minimum 10" diameter x 2" wide, made of first quality resin	As specified-Addendum #1
42. Lift bar - composition and installation used.	As Specified

Bid Form



## “HUSKYLITE®” Roll Out Cart Warranty

Rehrig Pacific Company offers a unique full warranty for a period of 10 years. Rehrig Pacific Company warrants that its HuskyLite® containers purchased will conform to all applicable specifications, will be free from defects in material and workmanship, and will be fit for the particular purpose intended by the Buyer. The conditions of this warranty include failure of the cart body, lid, lid attachments, wheels, axle, and all hardware.

Rehrig Pacific Company extends this warranty only to the first purchaser of the HuskyLite® containers.

### Warranty Coverage Exclusions

This warranty does not cover: (1) use under circumstances exceeding specifications, (2) Buyer or User abuse or vandalism, (3) unauthorized repair or alteration, (4) damage or failure as a result of incompatible, improperly installed, improperly operated, or defective lifting or dumping mechanisms, (5) damage or failure caused by natural calamities such as fire, storm, or high winds.

Rehrig Pacific Company will not be liable for any claims of loss of business, loss of profits, loss of income or any other losses or expense which exceeds the purchase price of the allegedly defective container.

### Administration of Warranty

Any component that fails during the 10 year warranty will be repaired or replaced at no cost to the Buyer provided that:

- (1) Buyer notifies Rehrig Pacific Company in writing no later than the end of the applicable warranty period of the claimed defect;
- (2) Buyer agrees that Rehrig Pacific Company shall have the right to inspect and test the allegedly defective container;
- (3) Determination of the alleged failure shall be made jointly in the judgment of the Buyer and Manufacturer;
- (4) The serial number(s) of the defective container(s) shall be submitted via email to Rehrig Pacific Company using the electronic warranty form. Each serial number must be accompanied by the appropriate warranty code identifying where the failure occurred.  
Rehrig Pacific Company reserves the right to recycle the defective containers. Buyer agrees to empty, disassemble, and stack containers for shipment back to Rehrig Pacific Company. Rehrig Pacific Company shall be responsible for setting up shipment and the associated freight charges.
- (5) Any repaired or replaced component will assume the remainder of the 10-year warranty from the original cart's initial purchase date.
- (6) Rehrig Pacific reserves the right to either replace or repair the defective component.

Cart Production Facilities: Headquarters: 4010 East 26<sup>th</sup> Street, Los Angeles, CA 90023, Phone 323.262.5145, Fax 323.269.8506  
 • 1738 W. 20<sup>th</sup> Street, Erie, PA 16502, Phone 814.455.8023, Fax 814.455.3997 • 1000 Raco Court, Lawrenceville, GA 30045, Phone 770.339.9888, Fax 770.339.4840 • 8875 Commerce Drive, De Soto, KS 66018, Phone 913.585.1175, Fax 913.585.1563  
 • 7800 100<sup>th</sup> Street, Pleasant Prairie, WI 53158 Phone 262-947-3312, Fax 262.947.3355

Warranty





## 95 Gallon Universal Roll Out Cart Specifications

<b>Manufacturing Process:</b>	Injection Molding
<b>Material:</b>	High-density polyethylene resin (HDPE) Manufacturer: Exxon Type: HD-6605 Color pigment and ultraviolet inhibitor compounded at 2% by weight
<b>Wall Thickness:</b>	Cart Minimum: 0.175 inches Critical Wear Points: 0.185 inches (Cart Bottom, handle & lift mechanisms) Lid Minimum: 0.140 inches
<b>Cart Dimensions:</b>	Height (includes lid): 45.13 inches Width: 28.70 inches Depth: 33.73 inches Resin weight: 34.10 pounds Assembled weight: 46 pounds Gripping diameter: 27 inches Capacity: 95 gallons Load Rating: 332.50 pounds
<b>Imprinting:</b>	Hot stamp process permanently imprints logos and other information including serial numbers and user instruction
<b>Lid Opening:</b>	270 degrees
<b>Lid Assembly:</b>	Carts are shipped with the lids already attached.
<b>Catch Bar:</b>	Integrally molded plastic catch bar or 1" corrosion resistant zinc plated steel catch bar which is easily installed
<b>Axle:</b>	High strength, low alloy steel, 3/4 inches x 23.8 inches, zinc plated or powder coated equivalent for corrosion protection.
<b>Wheel:</b>	12" x 1.75" injection-molded, rubber treaded, snap-on wheel with 1.4" integrated spacers
<b>Handle:</b>	Handle attachments are integrally molded part of the container body with a gripping area of 16 inches. Clearance between the cart body and the inside edge of the handle has been maximized to provide optimum control of a fully loaded cart
<b>Lift System Compatibility:</b>	Compatible with American semi-automated bar-locking lifters and fully automated arm lifters.
<b>Truckload Quantity:</b>	486, stacked 9 high

**Product Specs**

A FAMILY TRADITION OF GROWTH, SERVICE AND INNOVATION



## 65 Gallon Universal Roll Out Cart Specifications

<b>Manufacturing Process:</b>	Injection Molding
<b>Material:</b>	High-density polyethylene resin (HDPE) Manufacturer: Exxon Type: HD-6605 Color pigment and ultraviolet inhibitor compounded together at 2% by weight
<b>Wall Thickness:</b>	Cart Minimum: 0.175 inches Critical Wear Points: 0.185 inches (Cart Bottom, handle & lift mechanisms) Lid Minimum: 0.140 inches
<b>Cart Dimensions:</b>	Height (includes lid): 40.5 inches Width: 26.7 inches Depth: 28.11 inches Resin weight: 27.5 pounds Assembled weight: 36 pounds Capacity: 66.25 gallons Load Rating: 227.5 pounds
<b>Imprinting:</b>	Hot stamp process permanently imprints logos and other information including serial numbers and user instruction
<b>Lid Opening:</b>	270 degrees
<b>Lid Assembly:</b>	Carts are shipped with the lids already attached
<b>Catch Bar:</b>	Integrally molded plastic catch bar or 1" corrosion resistant zinc plated steel catch bar which is easily installed
<b>Axle:</b>	High strength, low alloy steel 3/4 inches x 23.8 inches, zinc plated or powder coated equivalent" for corrosion protection
<b>Wheel:</b>	10" x 1.75" blow-molded plastic, snap-on, with integrated spacer
<b>Handle:</b>	Handle attachments are integrally molded part of the container body with a gripping area of 12 inches. Clearance between the cart body and the inside edge of the handle has been maximized to provide optimum control of a fully loaded cart
<b>Lift System Compatibility:</b>	Compatible with American semi-automated bar-locking lifters and fully automated arm lifters.
<b>Truckload Quantity:</b>	648, stacked 9 high

**Product Specs**

A FAMILY TRADITION OF GROWTH, SERVICE AND INNOVATION



65 ROC

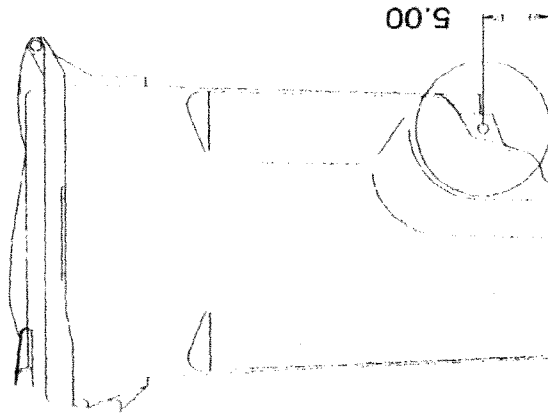
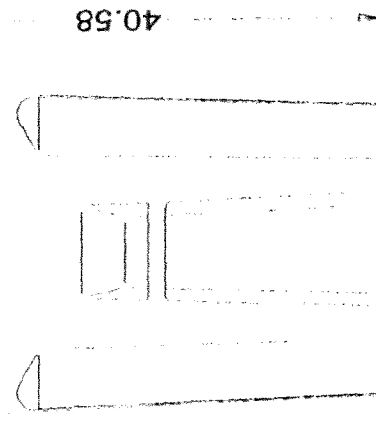
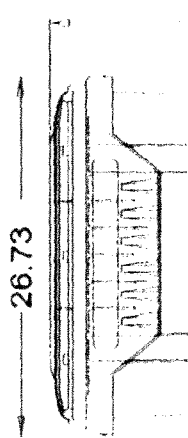
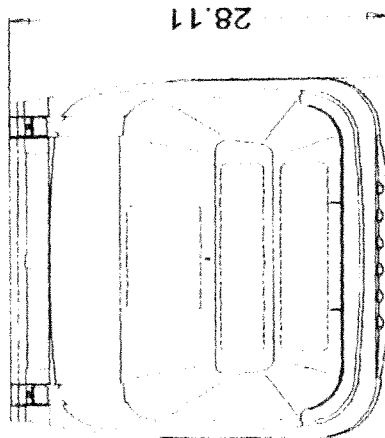

This drawing is the property of Rehrig Pacific Company ("Rehrig") and contains proprietary and confidential information belonging to Rehrig. This drawing is made available to the recipient on the specific condition that neither it nor the information contained therein will be copied or disclosed by the recipient except for internal review purposes or to obtain technical information from an equipment manufacturer who has been advised of and agrees to be bound by the terms of this agreement. Recipient agrees to immediately return this drawing and all copies thereof upon Rehrig's demand.

©2007 Rehrig Pacific Company

**Rehrig Pacific Company**  
Since 1913

65NB ROC

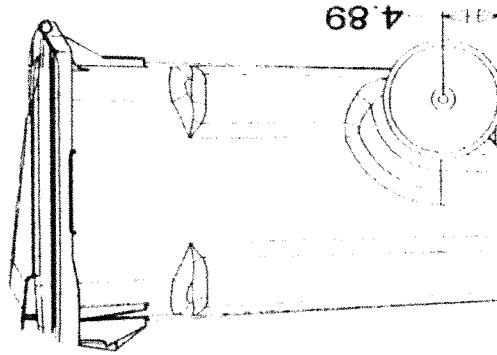
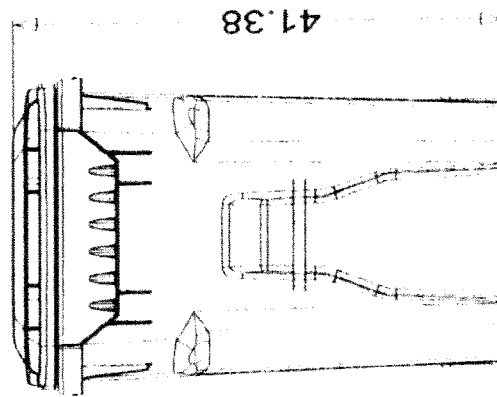
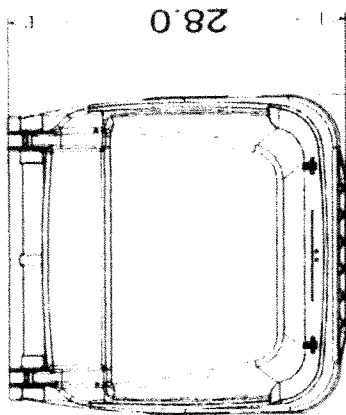

This drawing is the property of Rehrig Pacific Company ("Rehrig") and contains proprietary and confidential information belonging to Rehrig. This drawing is made available to the recipient on the specific condition that neither it nor the information contained therein will be copied or disclosed by the recipient except for internal review purposes or to obtain technical information from an equipment manufacturer who has been advised of and agrees to be bound by the terms of this agreement. Recipient agrees to immediately return this drawing and all copies thereof upon Rehrig's demand.  
©2007 Rehrig Pacific Company



95U ROC 12" Wheel  
Three Tiered Lid

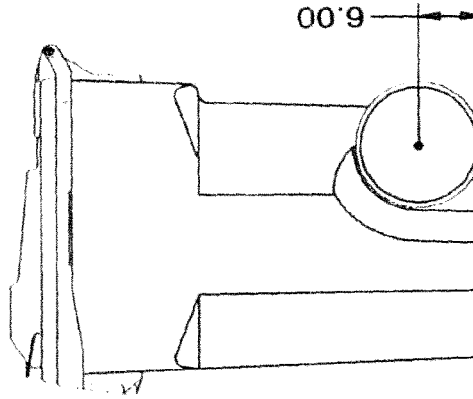
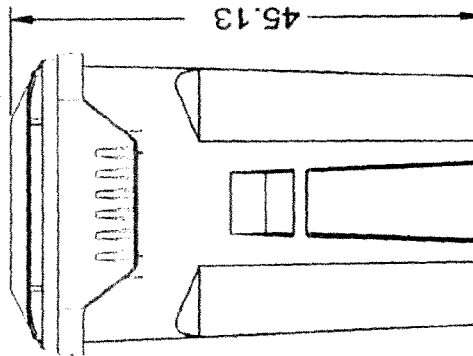
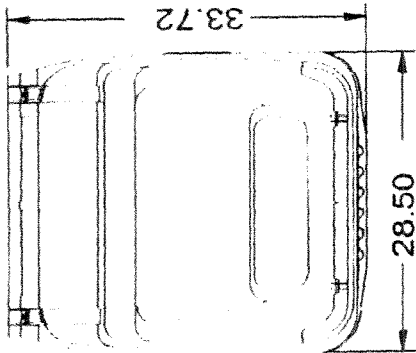

This drawing is the property of Rehrig Pacific Company ("Rehrig") and contains proprietary and confidential information belonging to Rehrig. This drawing is made available to the recipient on the specific condition that neither it nor the information contained therein will be copied or disclosed by the recipient except for internal review purposes or to obtain technical information from an equipment manufacturer who has been advised of and agrees to be bound by the terms of this agreement. Recipient agrees to immediately return this drawing and all copies thereof upon Rehrig's demand.  
©2007 Rehrig Pacific Company

**Rehrig Pacific Company**  
Since 1913

95U ROC 10" Wheel

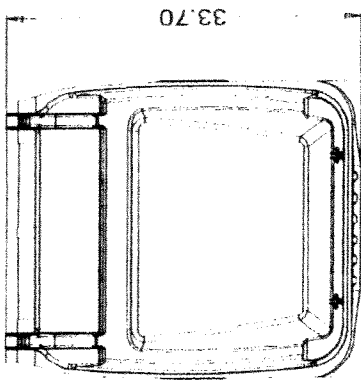

28.50

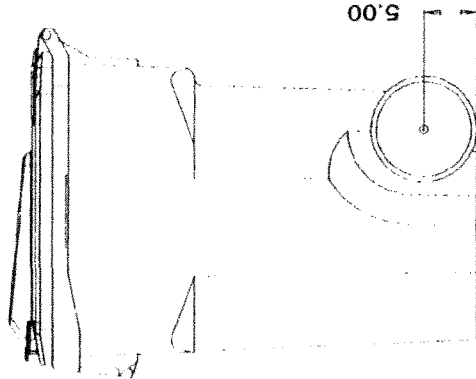
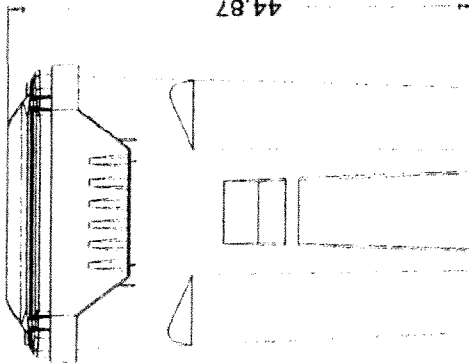

This drawing is the property of Rehrig Pacific Company ("Rehrig") and contains proprietary and confidential information belonging to Rehrig. This drawing is made available to the recipient on the specific condition that neither it nor the information contained therein will be copied or disclosed by the recipient except for internal review purposes or to obtain technical information from an equipment manufacturer who has been advised of and agrees to be bound by the terms of this agreement. Recipient agrees to immediately return this drawing and all copies thereof upon Rehrig's demand.

©2007 Rehrig Pacific Company



---

## Container Resin Weight

When considering the overall strength characteristics and longevity of a plastic container, there are several factors to consider. Processing, material, engineering (design) and weight are all factors in determining the durability of an automated container. It is our belief that the resin weight of a cart is crucial when producing a cart that can absorb and withstand the abuse inflicted by today's collection equipment.

Rehrig Pacific manufactures carts using the injection molding process. Unlike the rotational and blow molding processes, the injection molding process allows the manufacturer to design molds that allow for additional plastic to be injected into the critical wear areas of the container, such as the sidewalls, bottom and the lifting skirt area. This added material is a crucial component and is what gives our container the strength and durability to withstand the rigors of automated collection equipment. Other manufacturing processes outside of injection molding do not possess this ability, making it impossible to reinforce the areas of a container that matter the most.

In recent years, some container manufacturers (both injection and rotational molders) have made the decision to introduce carts to the market that possess far less resin than their original designs. While it is unclear as to why this decision was made, rising costs of resin (raw material) appears to be the main factor. Some manufacturers have introduced carts with nearly 5 pounds less raw material (resin) to compete in the market. On a 34-pound cart (resin weight) this would represent roughly 15% less material. To include the reduction in resin weight, some of these manufacturers have decided to reduce or prorate their cart warranties to better prepare themselves for the increases in failures that they anticipate experiencing from these lower quality carts.

Unlike our competition, Rehrig Pacific Company has made the decision to continue to deliver high quality carts to the marketplace without compromising the durability of our products. Instead of removing plastic from our container, we have increased our capacity and moved our production closer to our customers. This allows us to better offset resin increases with lower freight rates.

Our container failure rate is approximately 0.25% and is testament to the design and durability of our products. Rehrig Pacific stands by our commitment to quality and we believe that we have the strongest and longest lasting container on the market today. That is why we continue to offer and stand by our 10-year, non-prorated warranty for our containers.

The unassembled resin weights of Rehrig Pacific's carts are:

35-gallon 17.9 lbs.  
65-gallon 27.5 lbs.  
95-gallon 34.2 lbs.

Product Specs



A FAMILY TRADITION OF GROWTH, SERVICE AND INNOVATION



## Graphic Arts Capabilities

Rehrig Pacific Company takes great pride in their ability to provide graphic material and other pertinent information on their automated roll out carts. With over (39) years of experience, Rehrig Pacific Company employs state-of-the-art equipment to insure legibility and clarity.

The first component begins with camera-ready artwork. Rehrig Pacific Company works with very capable vendors that can take an artistic rendition of a logo all the way to an actual digital file, which results in very clean and crisp artwork. From this point, the vendor turns the artwork into a "brand plate". Basically, it is a mirror image of the artwork transformed onto a silicone pad capable of withstanding heat up to 500 degrees F. This silicone pad, with a metal backing, is the brand plate.

The second component is the brand tape. The tape is used between the silicone pad and the product being branded, to transfer the logo, in a color of choice, to the product. The tape used is of very high quality to insure color stability and legibility to withstand the extreme temperature variances in various parts of the country.

The third component is the hot-stamping or branding machine. Rehrig Pacific Company uses sophisticated hot-stamping equipment to transfer the artwork from the silicone pad to the roll out cart. This equipment, with its varied adjustment capabilities, allows precise amounts of air pressure, temperature and dwells to provide consistency from brand to brand.

The last component involves Rehrig Pacific Company's quality assurance. After each individual hot-stamp, an employee inspects the product looking for any defects. If any are found, the product is rejected and adjustments are made. This is ongoing and continuous to insure consistent quality.

## In Mold Labeling (IML) Branding Option

We also offer **In-Mold Labeling**. IML is becoming very popular for recycling carts because it allows a customer to brand detailed pictures and graphics onto the container lid that show acceptable recyclable items and constantly educates the resident throughout the life of the program. If you would like additional information for this option, please contact your sales representative.

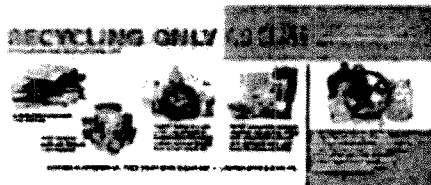

Product Specs



A FAMILY TRADITION OF GROWTH, SERVICE AND INNOVATION





## Reinforced Areas

The Rehrig Pacific "HuskyLite" automated carts are manufactured through the injection molding process. It is well documented that the injection molding process has some tremendous advantages in comparison to the rotational and blow molded processes. Some of the distinct advantages are:

- Uniform wall thickness
- Ability to mold complex shapes, add uniform reinforcement at critical wear points
- High Density Polyethylene (HDPE) for excellent part toughness and durability
- Use of recycled material
- High surface quality (smooth), easy to clean
- Repeated molding of tight tolerances

The above mentioned advantages have allowed Rehrig Pacific to incorporate some very unique design features into areas that studies have shown where carts take the most punishment or abuse. The areas where containers are most likely to absorb the most abuse are the lid, the cart bottom, the axle housing, the gripping area and the grab bar. Rehrig Pacific has intentionally reinforced these areas to assure the longevity and strength of our carts.

**Lid:** The Rehrig Pacific lid hinge design allows the lid to freely open and close with little effort. The lid attachment is a columnar extension of the lid, which greatly reduces the stress at the lid's attachment points. This feature effectively eliminates deformation and breakage commonly seen in other molding processes.

**Cart Bottom:** A molded-in double drag rail reinforced by plastic ribs for strength runs along the container's bottom edge. This beefed up strip of plastic prevents the container from wearing through when continuously dragged along paved surfaces. No other cart can match the wall thickness and wear ability of the Rehrig Pacific cart bottom.

**Axle Housing:** Rehrig Pacific's axle housing is unique in that it supports the axle in four areas ensuring longevity and superior mobility. In addition, the housing is not exposed to the resident therefore eliminating any possibility of the resident stepping on the axle to help tilt the cart backward (dangerous).

**Gripping Area:** The injection molding process assures that **every cart** manufactured has a uniform (same exact) wall thickness. Essentially, this means that every cart we manufacture has a wall thickness of 0.175". The consistent 0.175" wall thickness in the grabbing area (midway up cart body) adds strength needed to absorb the high gripping pressure of the automated gripping arms.

**Grab Bar:** Rehrig Pacific offers both an integrally molded plastic grab bar as well as a metal grab bar. The integrally molded plastic grab bar area has an increased wall thickness and reinforced ribbing to help withstand the rigors of semi-automated lifters. The grab bar design also features an increased radius to also prevent breakage in this area. Our metal grab bar is offered to customers who prefer metal to plastic.

Product Specs



---

## Lid Design

The Rehrig Pacific Company's lid performance can be attributed to the following design features:

- Our lids are molded from the same material as our containers. The lid design is of such configuration that it will not warp, bend, slump or distort to such an extent that it no longer fits flush on the container properly.
- The lid was designed to fit the container's body air tight, eliminating intrusion from wind, rain and vermin. The body's raised edge aligns the lid, ensuring the container complies with "insect free ordinances" and prevents intrusion of rainwater, rodents, flies, etc. The 3/4 inch raised edge prevents the lid from opening in high winds.
- The unique continuous lid handle design allows the resident to easily pick up the lid with one hand.
- The lid hinge design allows the lid to freely open and close with little effort. The lid attachment is a columnar extension of the lid, which greatly reduces the stress at the lid's attachment points. This feature effectively eliminates deformation and breakage commonly seen in other molding processes.
- The lid is crowned to allow for water runoff.





### Assembly Instructions

#### Lids

Containers are shipped with the lids completely attached and assembled. However when the need to attach a lid does arise, it will be very easy to accomplish. To assemble the lid, place the lid on top of the container, lining up the two (2) extended pieces of plastic from the lid into the handle area. Then place the hinge pins into the side holes on each side of the handle area making sure the hinge pins pass through the extended piece of plastic from the lid. Finally, push the hinge pins into place using a fair amount of pressure with either your hand or rubber mallet.

#### Axle and Wheels

Our containers are shipped in stacks of (9) high with the bottom cart of each stack fully assembled (lids, axles and wheels). All other containers have the axles and wheels with integrated spacers conveniently placed in the bottom of each individual container. To assemble the axle assembly, first slide the axle through all four holes in the axle housing until there is an equal amount of axle space extending beyond the end of the axle housing. Finally, place the wheel onto the axle until it "snaps" firmly into the groove on the axle. It's that easy!

**The average wheel assembly time utilizing our integrated spacer snap on wheel is 8 to 10 seconds!**

ROLL OUT CART ASSEMBLY

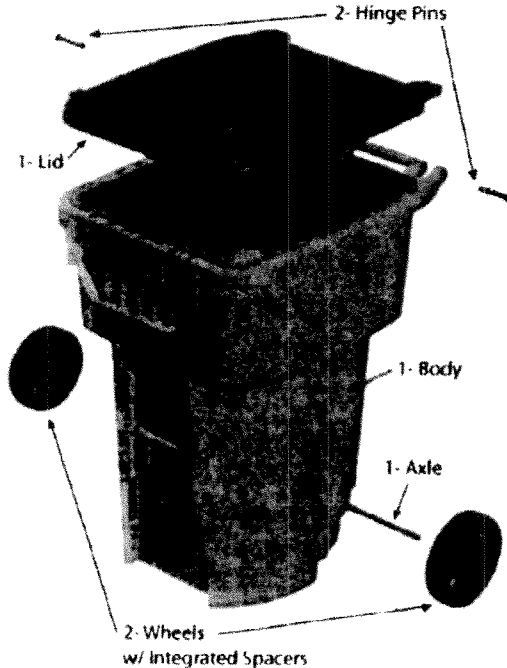

Product Specs



A FAMILY TRADITION OF GROWTH, SERVICE AND INNOVATION

# TESTING REPORT

DATE: 7 March 2002  
 SUBJECT: Trash carts  
 PRODUCT IDENTIFICATION: Rehrig Pacific 65 Gallon Universal Cart

TEST: WIND TUNNEL

TEST DESCRIPTION: This test is a measure of the stability of the cart in a high wind. Although not specifically tied to the basic purpose of the cart, most consumers would object to a cart that often tipped over and spilled the contents.

MINIMUM PERFORMANCE STANDARD: No standard has been set although some local standards may exist.

TEST PROCEDURE:

1. A large wind tunnel with a 54 inch diameter exit opening is used for the test. The wind was supplied by a Gates Super HC drive with capability to achieve various velocities.
2. Position the cart in the steady wind stream zone. (Approx. 48 inches from the opening.)
3. The bottom of the cart is to be level with the exit opening and is to rest on a concrete surface that has a surface texture similar to a roadway.
4. Test cart in three orientations toward the wind tunnel opening – front, side and back.
5. In each orientation, the cart should be tested against a barrier to simulate performance against a street curb. The barrier should prevent the cart from sliding.
6. Measure the air velocity at the leading surface of the cart using a certified volometer. Placement of the volometer in front of the cart and a few inches down from the top of the cart is ideal.
7. The wind velocity is raised in increments with sufficient time between changes to monitor whether the cart is stable. The highest wind velocity achieved is recorded.
8. The carts are blocked against a barrier that is placed behind the wheels. The point of non-stability (end point) is when the cart tipped over. The wind speed is taken as the average of at least 3 repetitions.
9. Modifications in cart characteristics or positioning may also be tested and noted.

TEST RESULTS:

	Orientation Towards Wind Tunnel		
	Front	Side	Back
Highest Stable Wind Speed (Blocked)	30 mph	42 mph	40 mph

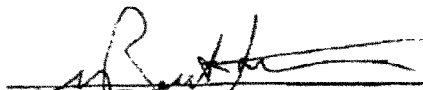
  
 A. Brent Strong  
 Professor, Manufacturing Engineering Technology  
 Brigham Young University, Provo, UT 84602

## TESTING REPORT

DATE: 9 January 2002

SUBJECT: Trash carts

PRODUCT IDENTIFICATION: Rehrig Pacific 95 Gallon Universal Cart – blow molded wheels

TEST: WIND TUNNEL

**TEST DESCRIPTION:** This test is a measure of the stability of the cart in a high wind. Although not specifically tied to the basic purpose of the cart, most consumers would object to a cart that often tipped over and spilled the contents.

**MINIMUM PERFORMANCE STANDARD:** No standard has been set although some local standards may exist.

**TEST PROCEDURE:**

1. A large wind tunnel with a 54 inch diameter exit opening is used for the test. The wind was supplied by a Gates Super HC drive with capability to achieve various velocities.
2. Position the cart in the steady wind stream zone. (Approx. 48 inches from the opening.)
3. The bottom of the cart is to be level with the exit opening and is to rest on a concrete surface that has a surface texture similar to a roadway.
4. Test cart in three orientations toward the wind tunnel opening – front, side and back.
5. In each orientation, the cart should be tested against a barrier to simulate performance against a street curb. The barrier should prevent the cart from sliding.
6. Measure the air velocity at the leading surface of the cart using a certified volometer. Placement of the volometer in front of the cart and a few inches down from the top of the cart is ideal.
7. The wind velocity is raised in increments with sufficient time between changes to monitor whether the cart is stable. The highest wind velocity achieved is recorded.
8. The carts are blocked against a barrier that is placed behind the wheels. The point of non-stability (end point) is when the cart tipped over. The wind speed is taken as the average of at least 3 repetitions.
9. Modifications in cart characteristics or positioning may also be tested and noted.

**TEST RESULTS:**

	Orientation Towards Wind Tunnel		
	Front	Side	Back
Highest Stable Wind Speed (Blocked)	46 mph	53 mph	52 mph

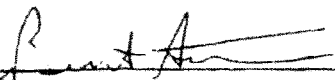

A. Brent Strong  
 Professor, Manufacturing Engineering Technology  
 Brigham Young University, Provo, UT 84602

**TALCO**  
POST CONSUMER PRODUCTS

**TALCO PLASTICS, INC.**  
1000 W. 10TH STREET  
MILWAUKEE, WI 53233  
TEL: 414.224.1100  
FAX: 414.224.1100



July 1, 2010

Jeff Hentges  
Vice President  
Rehrig Pacific Co.  
4010 East 26<sup>th</sup> Street  
Los Angeles, CA 90023

To Whom It May Concern:

This letter certifies that Talco Plastics, Inc. has provided Rehrig Pacific Co. in excess of 70 million pounds of Post Consumer, High Density Polyethylene (HDPE) resin in the past 15 years.

The Post Consumer Resin (PCR) material contains milk, water and juice bottles and is granulated, washed and palletized to remove any contaminants and is certified as 100% Post Consumer Resin.

Talco expanded its plant capacity a year ago and has the ability to supply Rehrig Pacific with additional PCR material requirements in the future.

Sustained by mutual collaboration and conviction, Talco Plastics enjoys a long standing partnership with Rehrig Pacific and continues to foster this relationship.

Thank you for giving Talco Plastics, Inc. this opportunity to participate in the dynamic growth of your business. If you have any further questions please do not hesitate to contact me.

Sincerely,

Matt Perera  
Vice President  
Post Consumer Operations  
Talco Plastics, Inc.

CC: Mike Riola - Rehrig Pacific Co.  
William O'Grady - Talco Plastics, Inc.





The Dow Chemical Company  
Midland, MI 48674  
U.S.A.

To whom it may concern:

This letter is to certify that The Dow Chemical Company supplies 100% prime HDPE resin (product code DMDB-7950) made to our production specifications. This includes appropriate levels of primary and secondary antioxidants. DMDB-7950 is used by Rehrig Pacific Company in the manufacture of roll-out carts.

If you have any further questions, please do not hesitate to contact me.

Sincerely,

*James R. Walley*

James R. Walley  
Account Executive  
Polyolefins & Elastomers Business Group

*Mailing Address*  
5710 E. 7th St. #227  
Long Beach, CA 90803  
562/986-7925 - Phone  
562/986-7928 - Fax

645040 100606A: JRW/kmo

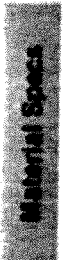

Section B. 1.b Cart Material



---

### Certification of Recycled Content

Rehrig Pacific Company will manufacture its Huskylite® 95 and 65 Gallon Refuse and Recycling containers in kelly green and purple with at least 20% post-consumer recycled content and the black containers with 97% in house regrind as long as it is available for the production of City and County of Denver containers if awarded the Recycle Carts #0587A contract. All black lids will also be manufactured using 97% post industrial content.

If you would like to introduce a higher percentage or have any other questions, please contact me. Thanks again for considering Rehrig Pacific Company for the supply of Denver's Polyethylene Recycling, Trash & Compost Cart needs.

*Jeris Queen*

---

Jeris Queen  
Sales Representative  
800-426-9189 Office  
214-292-4701 Direct  
214-638-7477 Fax  
JQueen@RehrigPacific.com

Material Specs







---

## Plastic Material

Rehrig Pacific Company uses only the highest grade HDPE especially formulated to meet the demands of refuse and recycling bin and cart applications. We currently purchase our resin from DOW Plastics & Exxon Mobil. The DOW material used in the manufacturing of the Rehrig Pacific carts and bins is DMDB-7905 NT 7 and the Exxon material is HD-6605, both materials are a narrow molecular weight copolymer that is designed for a wide range of injection molding applications. The materials provide excellent impact strength, stress crack resistance and process ability. These materials are ideally suited for articles requiring rugged physical performance in cold temperature environments, such as refuse and recycling carts and bins. If you would like to learn more about these materials please reference the Materials Safety Data Sheets (MSDS) attached.

## Ultraviolet Stabilization

Rehrig Pacific Company utilizes an H.A.L.S. (Hindered Amine Light Stabilizer) ultraviolet stabilizer (U.V.) package, which is considered a superior U.V. stabilizer package. This master-batch (or concentrate) contains maximum light stable color pigments that have the highest rating possible to prevent fading. The master-batch also contains ultraviolet inhibitors similar to or better than the Chemisorb 944 and thermal stabilizers in final levels to ensure minimal degradation in the field. At Rehrig Pacific we introduce our H.A.L.S. ultraviolet package into our rollout carts and bins at a 1.5%- 2.0% let down ratio by total resin weight of the container.

In contrast to "screener" U.V. stabilizers, the H.A.L.S. package protects the plastic resin at the chemical level. The package is designed to seek damaged or broken polymer chains at the chemical level and repair and protect the polymer chains from U.V. rays, thus maintaining the physical material properties of the plastic resin and container. Other U.V. stabilizers act as "screeners", similar to suntan lotion, in which the stabilizer attempts to screen the plastic and container from U.V. rays. Unfortunately, moisture can wash off "screeners", leaving the container exposed to harmful U.V. rays.

Color deterioration is controlled by the quality and type of pigment, separate from the deterioration of physical properties. U.V. rays interact with the pigment and can modify the pigment, depending on the amount and intensity of the U.V. rays and the quality of the pigment. Certain color pigments are more difficult to control especially variations of the color red and bright fluorescent colors.

Printed on Recycled Paper



A FAMILY TRADITION OF GROWTH, SERVICE AND INNOVATION



---

## Hot-Melt Compounding Certification

Rehrig Pacific Company blends high density polyethylene with UV-stabilized colorant using the hot-melt compounding process for the production of our recycling bins and 35, 65, and 95 gallon Huskylite® containers. All materials are in a molted state when injected into the mold in order to ensure uniform distribution of these materials throughout the container.

*Lisa Perkins*

---

Lisa Perkins  
Municipal Contract Manager

Printed on Recycled Paper

Material Specs



A FAMILY TRADITION OF GROWTH, SERVICE AND INNOVATION

## Handling Considerations

Material Safety Data (MSD) sheets for the product are available from Dow Plastics, a business group of The Dow Chemical Company and its subsidiaries, to help customers further satisfy their own safe handling and disposal needs and those that may be required by OSHA. Material Safety Data sheets on Dow products are intended to provide customers with essential information on such topics as Health and Worker Safety, Combustibility, and Disposal Considerations. Such information should be requested from the supplier(s) of any product(s) prior to working with it. As various additives and processing aids used in fabrication have their own safe use profile, their possible influence on handling and disposal must be investigated separately. For "Regulated" uses, such as food contact, your Dow sales representative can obtain compliance letters for specific resins.

### Disposal

DO NOT DUMP INTO ANY SEWERS, ON THE GROUND, OR INTO ANY BODY OF WATER. All disposal methods must be in compliance with all Federal, State/provincial, and local laws and regulations. Waste characterizations and compliance with applicable laws are the responsibility solely of the waste generator.

THE DOW CHEMICAL COMPANY HAS NO CONTROL OVER THE MANAGEMENT PRACTICES OR MANUFACTURING PROCESSES OF PARTIES HANDLING OR USING THIS MATERIAL. THE INFORMATION PRESENTED HERE PERTAINS ONLY TO THE PRODUCT AS SHIPPED IN ITS INTENDED CONDITION AS DESCRIBED IN MSDS SECTION 2 (Composition/Information On Ingredients). FOR UNUSED AND UNCONTAMINATED PRODUCT, the preferred options include sending to a licensed, permitted recycler, reclaimer, incinerator or other thermal destruction device, and landfill. These polymers have high heat values and should be incinerated only in units designed to handle high heats of combustion. In landfill, these polymers are inert, do not degrade quickly, form a strong and permanent soil base, and evolve virtually no gases or leachates known to pollute water resources.

As a service to its customers, Dow can provide names of information resources to help identify waste management companies and other facilities which recycle, reprocess, or manage chemicals or plastics, and that manage used drums. For more details, contact The Dow Chemical Company Customer Information Center at 1-800-441-4369. In Mexico, call 95-800-441-4369.

### Product Stewardship

The Dow Chemical Company has a fundamental concern for all who make, distribute, and use its products, and for the environment in which we live.

This concern is the basis for our Product Stewardship philosophy by which we assess the health and environmental information on our products and take appropriate steps to protect employee and public health, and our environment. Our Product Stewardship program rests with each and every individual involved with Dow products -- from the initial concept and research, to manufacture, use, sale, and disposal of each product.

### Customer Notice

Dow strongly encourages its customers to review both their manufacturing processes and their applications of Dow products from the standpoint of human health and environmental quality to help ensure that Dow products are not used in ways for which they are not intended or tested. Dow personnel will assist customers in dealing with ecological and product safety considerations. Dow product literature, including MSD sheets, should be consulted prior to use of Dow products. Your Dow Plastics sales representative can arrange the proper contacts, or write to Dow Plastics.

### Additional Information

For more information in the United States or Canada, call 1-800-441-4369. In Mexico, call 95-800-441-4369.

NOTICE: No freedom from infringement of any patent owned by Dow or others is to be inferred. Because use conditions and applicable laws may differ from one location to another and may change with time, Customer is responsible for determining whether products and the information in this document are appropriate for Customer's use and for ensuring that Customer's workplace and disposal practices are in compliance with applicable laws and other governmental enactments. Dow assumes no obligation or liability for the information in this document. **NO WARRANTIES ARE GIVEN; ALL IMPLIED WARRANTIES OF MERCHANTABILITY OR FITNESS FOR A PARTICULAR PURPOSE ARE EXPRESSLY EXCLUDED.**

NOTICE: If products are described as "experimental" or "developmental": (1) product specifications may not be fully determined; (2) analysis of hazards and caution in handling and use are required; and (3) there is greater potential for Dow to change specifications and/or discontinue production.

NOTICE REGARDING MEDICAL APPLICATION RESTRICTIONS: The Polyolefins business of The Dow Chemical Company does not recommend any Dow product or sample product for use: (A) in any commercial or developmental application which is intended for contact with human internal body fluids or body tissues, regardless of the length of time involved; (B) in any cardiac prosthetic device application, regardless of the length of time involved, including, without limitation, pacemaker leads and devices, artificial hearts, heart valves, intra-aortic balloons and control systems, and ventricular bypass assisted devices; (C) as a critical component in any medical device that supports or sustains human life; and (D) specifically by pregnant women or in any applications designed specifically to promote or interfere with human reproduction.

The Dow Chemical Company, 2040 Dow Center, Midland, MI 48674  
 Dow Chemical Canada Inc., 1086 Modeland Rd., P.O. Box 1012, Samia, Ontario, N7T 7K7, Canada  
 Dow Química Mexicana, S.A. de C.V., Torre Optima - Mezzanine, Av. Paseo de Las Palmas No. 405,  
 Col. Lomas de Chapultepec, 11000 Mexico, D.F., Mexico



Printed in U.S.A.

\*Trademark of The Dow Chemical Company.

v01

Material Specs



## ExxonMobil HD 6605

### Injection Molding HDPE

#### Material Description

**HD 6605** is a narrow molecular weight hexene copolymer designed for a wide range of injection molding applications, offering excellent ESCR with good stiffness-toughness balance. Ideally suited for articles requiring rugged physical performance in cold temperature environments.

**HD 6605.70** with standard processing antioxidants

**HD 6605.29** with UV-8 protection package

#### Typical Applications

Waste carts  
Recreational vehicle components  
Industrial closures  
Automotive components

Resin Properties	Test Based On <sup>3</sup>	Units	Typical Value <sup>1</sup>
Melt Index	ASTM D-1238 (190°C, 2.16 kg)	g/10 min.	5
Density	ASTM D-4883	g/cm <sup>3</sup>	0.948
Melting Point	ExxonMobil Method	°C (°F)	130 (266)
Molded Properties <sup>2</sup>			
Flexural Modulus	ASTM D-790	MPa (psi)	710 (102,400)
1% Secant	Procedure B		
Tensile Yield Stress	ASTM D-638	MPa (psi)	21.2 (3060)
Tensile Break Elongation	ASTM D-638	%	70
Tensile Impact @ - 40°C	ASTM D-1822	kJ/m <sup>2</sup> (ft-lb/in <sup>2</sup> )	325 (155)
Notched Izod Impact @ - 40°C	ASTM D-256	J/m(ft-lb/in)	70.5 (1.32)
Brittleness Temperature	ASTM D-746	°C (°F)	< -70 (< -94)
Environmental Stress Crack Resistance, F <sub>50</sub>	ASTM D-1693 Cond. B, 10%	hr	18
Deflection Temperature @ 66 psi	ASTM D-648	°C (°F)	67 (152)
@ 264 psi			38 (101)

1 Values given are typical and should not be interpreted as specification. Values may change with future grade development.

2 Properties are based on injection molded samples.

3 ASTM test procedures may be modified to accommodate operating conditions or facility limitations.

### Food Packaging

Grades have FDA compliance. Restrictions may apply, contact your ExxonMobil representative for more details.

September 2001

©2001 ExxonMobil. To the extent the user is entitled to disclose and distribute this document, the user may forward, distribute, and/or photocopy this copyrighted document only if unaltered and complete, including all of its headers, footers, disclaimers, and other information. You may not copy this document to a Web site. The information in this document relates only to the named product or materials when not in combination with any other product or materials. We based the information on data believed to be reliable on the date compiled, but we do not represent, warrant, or otherwise guarantee, express or implied, the accuracy, reliability, fitness for a particular purpose, suitability, accuracy, reliability, or completeness of this information or the products, materials, or processes described. The user is solely responsible for all determinations regarding any use of material or product and any process in its territories of interest. We expressly disclaim liability for any loss, damage, or injury directly or indirectly suffered or incurred as a result of or related to anyone using or relying on any of the information in this document. There is no warranty against patent infringement, nor any endorsement of any product or process, and we expressly disclaim any contrary implication. The terms, "we", "our", "ExxonMobil Chemical", or "ExxonMobil" are used for convenience, and may include any one or more of ExxonMobil Chemical Company, Exxon Mobil Corporation, or any affiliates they directly or indirectly steward.

Material Specs



---

### Statement of Recycle Ability

Rehrig Pacific Company certifies that all material used to manufacture our 35, 65, and 95-gallon containers are 100% recyclable, including plastic resin and steel. When the timing is right, we can assist you in order to close the loop on recycling.

*Lisa Perkins*

---

Lisa Perkins  
Municipal Contract Manager

Printed on Recycled Paper

Material Specs



A FAMILY TRADITION OF GROWTH, SERVICE AND INNOVATION

## Product Information



# DOW DMDB-7950 NT 7

## High Density Polyethylene Resin

- Injection molding
- Roll-out trash carts and other large parts
- Excellent impact strength, stress crack resistance and processability
- Very narrow molecular weight distribution
- Complies with U.S. FDA 21 CFR 177.1520 (c) 3.1a  
Consult the regulations for complete details.

DOW DMDB-7950 NT 7 High Density Polyethylene (HDPE) Resin is intended for use in injection molding applications such as roll-out trash carts and

other large parts with short molding cycles. It is produced via UNIPOL™ Process Technology from Dow and has been designed to meet the rigorous performance

characteristics of impact resistance, environmental stress crack resistance, stiffness, and low warpage, while maintaining excellent moldability.

Physical Properties	Test Method	Values: English (SI)
<b>Resin Properties</b>		
Melt Index (I.) @190°C/2.16 kg, g/10 min	ASTM D 1238	5.75
Density, g/cm <sup>3</sup>	ASTM D 792	0.948
DSC Melting Point, °F (°C)	Dow Method	266 (130)
DSC Crystallization Point, °F (°C)	Dow Method	244 (118)
Vicat Softening Point, °F (°C)	ASTM D 1525	261 (127)
<b>Molded Plaque Properties<sup>(2)</sup></b>		
Hardness, Shore D	ASTM D 2240	54
Flexural Modulus, 2% Secant, psi (MPa)	ASTM D 790 B	146,000 (1010)
Tensile Strength at Break, psi (MPa)	ASTM D 638	3600 (26)
Tensile Strength at Yield, psi (MPa)	ASTM D 638	3600 (25)
Tensile Elongation at Break, %	ASTM D 638	1200
Tensile Elongation at Yield, %	ASTM D 638	8
Tensile Impact Strength, ft-lb/in. <sup>2</sup> (kJ/m <sup>2</sup> )	ASTM D 1822, Type S	50 (105)
Environmental Stress Crack Resistance, 122°F (50°C), F <sub>50</sub> , 100% Igepa® <sup>(1)</sup> , hrs.	ASTM D 1893	40
Brittleness Temperature, °F (°C)	ASTM D 746	<-105 (<-76)
Deflection Temperature Under Load @ 66 psi (0.45 MPa), °F (°C)	ASTM D 648	154 (68)

- (1) Typical values, not to be construed as specifications. Users should confirm results by their own tests.  
 (2) Molded and tested in accordance with ASTM D4976.

\*Trademark of The Dow Chemical Company

Printed on Recycled Paper

-See "Handling Considerations" attached

Dow Plastics, a business group of The Dow Chemical Company and its subsidiaries.

Published 03/04  
Form No 305-02984-0304X

Material Specs