

CONCESSION AGREEMENT  
AND  
TERMINAL BUILDING PREMISES LEASE

between

THE CITY AND COUNTY OF DENVER

For and on behalf of its Department of Aviation

and

ENTERPRISE LEASING COMPANY OF DENVER, LLC

dba

ENTERPRISE RENT A CAR and NATIONAL CAR RENTAL  
and ALAMO RENT A CAR

TABLE OF CONTENTS

SECTION 1 ..... 1

DEFINITIONS ..... 1

    1.1. Airport Customer..... 1

    1.2 Canopies and Roadways..... 1

    1.3. Customer Facility Charge or “CFC” ..... 2

    1.4 Manager ..... 2

    1.5. Rental Car Transaction Day ..... 2

    1.6. Terminal Building Premises ..... 2

    1.7 Terminal Improvements ..... 2

SECTION 2 REPRESENTATIONS ..... 2

    2.1. Consideration..... 2

    2.2. Representations and Covenants by the City. .... 2

    2.3. Representations and Covenants by the Company ..... 3

SECTION 3 LEASE OF THE TERMINAL BUILDING PREMISES; GRANT OF CONCESSION ..... 3

    3.1. Lease of Terminal Building Premises ..... 3

    3.2. Access: Shuttle Vehicle Access..... 3

    3.3. Modification of Access Route ..... 4

    3.4. Grant of Concession. .... 4

SECTION 4 CONCESSION AGREEMENT TERM ..... 5

    4.1. Term of the Agreement. .... 5

    4.2. Surrender of Possession..... 5

    4.3. Reversion. .... 5

    4.4. Removal of Company Property ..... 5

    4.5. Effect of Holding Over..... 5

SECTION 5 ..... 5

ACQUISITION, CONSTRUCTION AND INSTALLATION OF THE TERMINAL IMPROVEMENTS..... 5

    5.1. Terminal Improvements; Plans and Specifications ..... 5

    5.2. Title to the Terminal Improvements ..... 5

    5.3. No Warranty of Condition or Suitability by the City ..... 6

SECTION 6 PAYMENTS UNDER THIS CONCESSION AGREEMENT ..... 6

    6.1. Terminal Premises Rentals. .... 6

    6.2. Concession Fees. .... 7

    6.3. Place and Manner of Payments to the City ..... 11

    6.4. Payments Under Agreement in Addition to Other Payments..... 11

    6.5. Pass Through of Concession Fees ..... 12

    6.6. Rental Car Customer Facility Charge (CFC) ..... 12

    6.7. Obligations of Company Under Agreement Unconditional..... 13

SECTION 7 SPECIAL COVENANTS..... 14

    7.1. Financial Statements of Company..... 14

7.2.	Company to Maintain its Corporate Existence.....	14
7.3.	Defense and Indemnification.....	15
7.4.	Taxes on Amounts Payable by City .....	16
7.5.	Quiet Enjoyment.....	16
7.6.	Patents and Trademarks.....	16
7.7.	Assignments and Subleases by Company. ....	16
7.8.	Performance Bond.....	16
7.9.	Agreements with United States of America .....	17
7.10.	Master Plan for Airport .....	17
7.11.	Disadvantaged Business Enterprises.....	17
7.12.	Concession Agreements with other Car Rental Companies.....	18
<b>SECTION 8 USE AND MAINTENANCE OF FACILITIES .....</b>		<b>18</b>
8.1.	Permitted Use.....	18
8.2.	Limitations Upon Use and Location.....	18
8.3.	Compliance with Municipal Regulations.....	18
8.4.	Bond Ordinances .....	20
8.5.	Compliance with Other Governmental Regulations.....	20
8.6.	Utilities.....	20
8.7.	Company Property.....	21
8.8.	Disposition of Company Property at End of Agreement Term.....	21
8.9.	Repairs, Maintenance and Replacement.....	21
8.10.	Right to Enter, Inspect and Make Repairs.....	22
8.11.	Signs .....	22
8.12.	Vending Machines.....	22
8.13.	Purchases by Company.....	23
8.14.	Sale of Food and Beverages.....	23
8.15.	Use, Possession, or Sale of Alcohol or Drugs .....	23
8.16.	City Smoking Policy.....	23
8.17.	Security.....	23
8.18.	Operations.....	24
<b>SECTION 9 LOSS OF AND LIABILITIES PERTAINING TO TERMINAL BUILDING PREMISES .....</b>		<b>28</b>
9.1.	Property Insurance.....	28
9.2.	Liability Insurance.....	28
9.3.	Payment of Insurance Proceeds.....	28
9.4.	Continued Obligation to Pay Rentals.....	28
9.5.	Limitations as to Policies.....	29
9.6.	Failure of Company to Provide Insurance.....	29
9.7.	Notification of Loss and Compliance with Policies.....	29
<b>SECTION 10 LIENS AND CLAIMS .....</b>		<b>29</b>
10.1.	Prompt Payment of Taxes and Fees.....	29
10.2.	Worker's Compensation Insurance.....	30

10.3.	Mechanic's and Materialmen's Liens.....	30
10.4.	Prompt Payment of Other Obligations. ....	30
10.5.	Right of Contest.....	30
10.6.	Nonpayment During Contest.....	30
SECTION 11	.....	31
11.1.	Events of Default Defined.....	31
11.2.	Remedies on Default. ....	32
11.3.	Cross Default With Facilities and Ground Lease .....	34
11.4.	No Remedy Exclusive. ....	34
11.5.	Agreement to Pay Fees and Expenses of Counsel.....	34
11.6.	No Additional Waiver Implied by One Waiver. ....	34
SECTION 12 MISCELLANEOUS	.....	35
12.1.	No Personal Liability.....	35
12.2.	Third Parties. ....	35
12.3.	No Limitation on Previous Agreements. ....	35
12.4.	Binding Effect. ....	35
12.5.	Execution in Counterparts.....	35
12.6.	Amendments, Changes, and Modifications.....	35
12.7.	Severability.....	35
12.8.	Notices.....	35
12.9.	Further Assurances. ....	36
12.10.	Applicable Law. ....	36
12.11.	City's Obligations Limited.....	36
12.12.	Compliance with Laws, Ordinances and Rules and Regulations....	37
12.13.	City Execution Of Agreement.....	37

APPENDIX NO. 1 - STANDARD FEDERAL ASSURANCES AND NONDISCRIMINATION

EXHIBIT A

DESCRIPTION OF TERMINAL BUILDING PREMISES AND TERMINAL IMPROVEMENTS

EXHIBIT C

ACDBE COMMITMENT FORM

EXHIBIT H

SHUTTLE BUS PICK UP AND DROP OFF AREA

EXHIBIT X

PROVISIONS FOR DESIGN AND CONSTRUCTION OF IMPROVEMENTS

## **CONCESSION AGREEMENT AND TERMINAL BUILDING PREMISES LEASE**

**THIS CONCESSION AGREEMENT AND TERMINAL BUILDING PREMISES LEASE (“Agreement”)** is dated as of the date stated on the City signature page below, between the City and County of Denver, Colorado, a municipal corporation and home rule city organized and existing under the Constitution and laws of the State of Colorado (**the "City"**), and Enterprise Leasing Company of Denver, LLC, dba Enterprise Rent A Car and National Car Rental and Alamo Rent A Car, a company organized under the State of Delaware and authorized to transact business in the State of Colorado (**the “Company”**).

### **RECITALS**

**WHEREAS**, the City operates and maintains a municipal airport known as "Denver International Airport" for the use and benefit of the public (**the "Airport"**); and

**WHEREAS**, the Company is engaged in the principal business of renting motor vehicles and desires to provide the service of renting motor vehicles to the public at the Airport upon the terms set forth below; and

**WHEREAS**, the City proposes to lease to the Company the Terminal Building Premises described in Exhibit A and to grant to the Company the right and privilege of operating at the Airport a non-exclusive concession for the rental of motor vehicles to the public in accordance with this Agreement which, among other matters, provides for payment of Terminal Premises Rentals, Concession Fees and other amounts described herein; and

**WHEREAS**, the Company and the City have entered into a “Facilities and Ground Lease” dated on or about the same date as this Agreement.

**NOW, THEREFORE**, in consideration of the respective representations and agreements contained herein, the City and the Company hereby agree as follows:

### **SECTION 1 DEFINITIONS**

**1.1. Airport Customer.** “Airport Customer” means a customer of the Company who has arrived at the Airport within 24 hours previous to entering into a motor vehicle rental agreement within a 20 mile radius of the Terminal Building at the Airport with the Company or taking delivery within a 20 mile radius of the Terminal Building at the Airport of a rental motor vehicle regardless of where the motor vehicles or services are returned, as more specifically defined in **Section 6.2C(i)**.

**1.2 Canopies and Roadways.** “Canopies and Roadways” means the canopies for the

east and west curbside waiting areas outside the Terminal, as shown on Exhibit H, and the roadways in connection therewith.

**1.3. Customer Facility Charge or “CFC”.** “Customer Facility Charge or “CFC” means a charge on the Company’s Airport Customers on a per Rental Car Transaction Day basis, for the purpose of paying the costs associated with the management of, improvements to, and expansion of the existing rental car facility area and related transportation facilities and the planning and design of future phases of the rental car program as deemed appropriate by the Manager, in an amount determined by the Manager, implemented through an Airport Rule and Regulation, and collected by the Company as required under **Section 6.6A**.

**1.4 Manager.** “Manager” means the Manager of the City’s Department of Aviation having jurisdiction over the management, operation and control of the Airport. “Manager’s authorized representative” or words of similar import shall mean the officer or employee of the City designated in writing by the Manager as the Manager’s authorized representative.

**1.5. Rental Car Transaction Day.** “Rental Car Transaction Day” means a twenty-four (24) hour period or fraction thereof for which an Airport Customer is provided the use of a rental motor vehicle for compensation regardless of the duration or length of the rental term. However, if the same motor vehicle is rented to more than one customer within one continuous twenty-four (24) hour period, then each such rental shall be calculated as a transaction day. A grace period of no more than two (2) hours after the last 24-hour day booked shall not be considered a separate transaction day.

**1.6. Terminal Building Premises.** “Terminal Building Premises” means the counter space and related common areas, if any, set forth in Exhibit A hereto, including the improvements constructed and installed thereon.

**1.7 Terminal Improvements.** “Terminal Improvements” means the improvements to the property constructed or installed upon the Terminal Building Premises such that they are classified as a fixture under applicable law and not including Company Property as defined in Section 8.6.

## **SECTION 2 REPRESENTATIONS**

**2.1. Consideration.** The City enters into this Agreement in consideration of the payment by Company as herein provided and of the performance and observance by Company of the covenants and agreements herein.

**2.2. Representations and Covenants by the City.** The City hereby represents and covenants that, subject to the provisions of the Charter:

- A. The City is a municipal corporation and home-rule city, duly organized and existing under the Constitution and laws of the State of Colorado.
- B. The City is authorized by the Colorado Constitution and the Charter of the City and County of Denver to enter into the transactions contemplated by this Agreement and to carry out its obligations hereunder.
- C. The City has title to the Terminal Building Premises.

**2.3. Representations and Covenants by the Company.** The Company hereby represents and covenants that:

- A. The Company is a corporation duly incorporated in the state specified on page one and in good standing in the State of Colorado, is not in violation of any provision of its Articles of Incorporation or its by-laws, has full corporate power to own its properties and conduct its business, has full legal right, power and authority to enter into this Agreement and consummate all transactions contemplated hereby and by proper corporate action has duly authorized the execution and delivery of this Agreement.
- B. This Agreement has been authorized, executed and delivered by the Company and constitutes the legal, valid and binding obligation of the Company enforceable against the Company in accordance with its terms.
- C. There are no pending or threatened actions or proceedings before any court or administrative agency which individually (or in the aggregate in the case of any group of related lawsuits) is expected to have a material adverse effect on the financial condition of the Company or the ability of the Company to perform its obligations under this Agreement.

### **SECTION 3**

#### **LEASE OF THE TERMINAL BUILDING PREMISES; GRANT OF CONCESSION**

**3.1. Lease of Terminal Building Premises.** The City hereby leases to the Company, and the Company hereby leases from the City, the Terminal Building Premises, including the improvements constructed and installed thereon and any property classified as a fixture under applicable law, on the terms and conditions set forth in this Agreement, including but not limited to the Company's agreement to pay Terminal Premises Rentals to the City in accordance with Section 6.1 hereof. The Terminal Building Premises shall be for the exclusive use of the Company.

**3.2. Access: Shuttle Vehicle Access.**

A. Subject to any rules and regulations heretofore or hereafter adopted and promulgated by the City regarding the Airport, including without limitation any nondiscriminatory rules and regulations governing entrance to and use of the Airport, the City shall provide the Company roadways or other rights-of-way for access, ingress to and egress from the Terminal Building Premises for the Company's employees, it's or their suppliers of materials and furnishers of service, and it's or their equipment, vehicles, machinery and other property. The foregoing shall not preclude the City or its concessionaires or licensees from making and collecting a charge for the use of public motor vehicle parking areas, sightseeing facilities, or ground transportation to or from the Airport furnished by the City or its concessionaires or licensees, or preclude the City from imposing any taxes, including without limitation, sales, use and occupation taxes, any permit or license fees, and any property taxes not inconsistent with the rights and privileges granted to the Company hereunder.

B. Subject to the provisions of Section 3.2 and Section 3.3, the City agrees to assign to the Companies island 4 of the curbside loading areas on the east and west sides of level 5 of the Terminal, and provide designated Shuttle Vehicle loading areas for the Company and each of the other Companies in accordance with the diagram attached hereto as Exhibit H.

C. If a Company for any reason ceases to operate as a concessionaire under its Concession Agreement with the City, the designated Shuttle Vehicle loading areas shall be reallocated by the remaining Companies, the Manager shall revise Exhibit H reflecting such agreed-upon reallocation, and a new and revised Exhibit H shall be substituted for Exhibit H, such action to be taken without the requirements of a formal amendment to this Agreement.

**3.3. Modification of Access Route.** The City may, at any time, temporarily close or consent to or request the closing of any roadway or other right-of-way for such access, ingress, and egress, and any other area at the Airport or in its environs presently or hereafter used as such, so long as a means of access, ingress, and egress reasonably equivalent to that formerly provided is substituted therefore and is concurrently made available therefore. The Company hereby releases and discharges the City of and from any and all claims, demands, or causes of action which the Company may now, or at any time hereafter, have against the City, arising or alleged to arise out of the closing of any roadway or other right-of-way for such access, ingress, and egress or other area at the Airport or in its environs used as such, so long as the City makes available a means of access, ingress, and egress reasonably equivalent to that existing prior to each such modification, if any.

**3.4. Grant of Concession.** The City hereby grants to the Company the right and the privilege of operating at the Airport a non-exclusive concession for the rental of motor vehicles to the public, including the right to occupy and use the Terminal Building Premises, together with necessary rights of ingress and egress, all in accordance with the terms of this Agreement. The City further grants to the Company the right and privilege of operating its motor vehicles upon the Airport in the conduct of its motor vehicle rental business in accordance with Airport rules and



regulations, as established and amended from time to time governing the operation of such motor vehicles upon the Airport including without limitation any fees for the use of roadway facilities imposed in such regulations.

#### **SECTION 4 CONCESSION AGREEMENT TERM**

**4.1. Term of the Agreement.** The term of this Agreement shall commence on January 1, 2014 and shall terminate on December 31, 2014. The Manager may, in her sole discretion, and upon written notice to the Company, offer an extension of the Term by any amount of time up to one (1) year, upon the same terms and conditions. If the Company agrees and the Term is extended, the Agreement as extended shall be terminable by the Manager upon six (6) months' written notice to the Company.

**4.2. Surrender of Possession.** No notice to quit possession at the termination of the Agreement shall be necessary, and the Company covenants peaceably to surrender possession of the Terminal Building Premises upon the termination of this Agreement. The Company shall surrender the Terminal Building Premises in good condition, reasonable wear and tear, acts of God and other casualties excepted.

**4.3. Reversion.** Upon termination of this Agreement, the Company shall cease to have any rights with respect to the Terminal Building Premises under this Agreement.

**4.4. Removal of Company Property.** Upon termination of this Agreement, the Company shall forthwith remove therefrom all Company Property installed by the Company pursuant to Section 8.7A, except as otherwise provided in Section 8.7B.

**4.5. Effect of Holding Over.** In the event that the Company holds over the use of or continues to occupy the Terminal Building Premises or any part thereof after the termination of this Agreement, such holding over shall be at sufferance at a rate of compensation to be fixed by the City but otherwise on the same terms and conditions as herein provided in the absence of a written agreement to the contrary.

#### **SECTION 5 ACQUISITION, CONSTRUCTION AND INSTALLATION OF THE TERMINAL IMPROVEMENTS**

**5.1. Terminal Improvements; Plans and Specifications.** The Company agrees that any additional Terminal Improvements shall be constructed in accordance with the provisions set forth in Exhibit X hereto.

**5.2. Title to the Terminal Improvements.** The Company shall be liable at all such

times for all risk, loss, and damages with respect to the Terminal Improvements or portions thereof. The City shall without further act maintain title to each component of the Terminal Improvements.

**5.3. No Warranty of Condition or Suitability by the City.** THE COMPANY SPECIFICALLY ACKNOWLEDGES THAT THE CITY MAKES NO WARRANTY, EXPRESS OR IMPLIED, AS TO THE TERMINAL IMPROVEMENTS OR THEIR CONDITION OR THAT THEY WILL BE SUITABLE FOR THE COMPANY'S PURPOSES OR NEEDS.

**SECTION 6  
PAYMENTS UNDER THIS CONCESSION AGREEMENT**

**6.1. Terminal Premises Rentals.**

**A.** The Company agrees to pay as Terminal Premises Rentals to the City each month during the term of this Agreement an amount equal to one-twelfth of the following estimated annual square foot rentals for the Terminal Building Premises:

**Amount Per Square Foot Per Year = \$60.00 per Square Foot**

The City shall establish and fix the Company's rentals, rates, fees, and charges in accordance with cost-accounting concepts and rate making procedures established and adopted by the Manager. Such rentals may be reestablished by the City pursuant to Section 6.1.C hereof.

**B.** If so provided by the City to the Terminal Building Premises, the Company agrees to pay the City the cost of common use facilities, equipment, services and maintenance to the Terminal Building Premises. Common use services may include, but are not limited to, insurance, law enforcement and/or security officers and trash/refuse removal from the Terminal Building Premises.

**C.** The City, acting by and through its Manager, may from time to time, at the Manager's sole discretion, and subject to the requirements of the General Airport Bond Ordinance, reestablish the rentals, fees and charges provided for in this Section 6.1.

**D.** Terminal Premises Rentals shall be payable by the Company commencing upon the, and thereafter on the first day of each succeeding month, in advance, during the term of this Agreement. In the event that the initial period for payment of Terminal Premises Rentals is less than one month, Terminal Premises Rentals for such period shall be calculated on a pro-rata basis. Terminal Premises Rentals shall immediately be deposited by the City in the Revenue Fund created under the General Airport Bond Ordinance for use as provided therein.

## 6.2. Concession Fees.

A. The Company agrees to pay as Concession Fees to the City during the term of this Agreement an amount equal to 10% of the Company's annual Gross Revenues, as defined below, derived from its operations under this Agreement, or the minimum annual guaranteed amount, whichever is greater; provided, however, that in the event of the occurrence of any of the following events, the minimum annual guaranteed amount, but not the percentage of Gross Revenues, shall be suspended for the period of time the condition continues to exist:

- (i) In the event of any national emergency wherein there is a curtailment, either by executive decree or legislative action, of the use of motor vehicles or aircraft by the general public; or
- (ii) In the event the number of civilian passengers enplaning at the Airport on scheduled airlines during a period of at least 60 consecutive days shall be less than 70% of the number of such enplaning passengers for the same period of time in the immediately preceding year by reason of (1) a strike involving one or more of the interstate airlines serving the Airport, (2) destruction or damage to all or a material portion of the Terminal Building at the Airport or the air operations area of the Airport by reason of fire or other casualty, or (3) occupation of the Airport in its entirety by the United States government or any of its agencies. An "air operations area" means any area of the Airport used or intended to be used for landing, takeoff or surface maneuvering of aircraft.

B. As used in this Section, the term "minimum annual guaranteed amount" shall mean, for each of the calendar years commencing on January 1, 2014, and thereafter during the term of this Agreement, an amount equal to 1) 85% of the combined total dollar amount of the Company's percentage-of-revenue compensation payable by the Company (or its predecessor operating the same brands) in the immediately preceding calendar year, or 2) the highest minimum annual guaranteed amount payable by the Company (or its predecessor operating the same brands) in any of the previous calendar years since 1999, whichever is greater.

C. As used in this Section, the term "**Gross Revenues**" shall mean, for all purposes in the Concession Agreement, all monies paid or payable to or due or received from Airport Customers by the Company, after discounts and coupons deducted at the time of rental, for:

- (i) All charges including but not limited to time and mileage charges, whether for cash or credit, for rentals of motor vehicles and all other authorized items or services from each customer of the Company who has arrived at the Airport within 24 hours previous to entering into a motor vehicle rental

agreement within a 20 mile radius of the Terminal Building at the Airport with the Company or taking delivery within a 20 mile radius of the Terminal Building at the Airport of a rental motor vehicle regardless of where the motor vehicles or services are returned, and shall include customers obtained through discount arrangements whereby the Company provides discounts to airlines, charters, cruise lines, or any other person, firm, or entity. This includes rentals of Airport based "fleet" motor vehicles and motor vehicles which are not assigned to the Company's Airport fleet. Motor vehicles shall include only those vehicles commonly classified as sedans, coupes, convertibles, station wagons, 4-wheel drive vehicles, recreational vehicles, pickup trucks, passenger vans, and such other vehicles as may be approved from time to time by the Manager. Motor vehicles shall not include trucks rated one ton or more other than pickup trucks; and

- (ii) Any charges for insurance offered incidental to such motor vehicle rentals including but not limited to accident and personal effects insurance; and
- (iii) Any charges for motor vehicles leased or delivered within a 20 mile radius of the Terminal Building at the Airport but later exchanged at any point other than within 20 miles of the Terminal Building at the Airport where exchanges of motor vehicles originally rented or delivered within such distance of the Airport are permitted by the Company; and
- (iv) All proceeds from the long-term lease of vehicles from any location on the Airport; and
- (v) The amount charged to the Company's Airport Customers which is separately stated on the rental agreement as an optional charge for waiver by the Company of its right to recover from the Airport Customer for damage to or loss of the vehicle rented; and
- (vi) The amount charged to the Company's Airport Customers at the commencement or the conclusion of the rental transaction for the cost of furnishing and/or replacing fuel provided by the Company; and
- (vii) The amount charged by the Company as a pass through to its Airport Customers of the Concession Fee; and
- (viii) All additional charges not expressly excluded under this provision, such as add-ons for GPS, child carriers, ski or bicycle roof-top carriers, travel accessories or conveniences, and services such as photocopying or mailing.

Only the following shall be excluded from the term "Gross Revenues":

- 1) Any Federal, State, County, or City sales or other similar taxes or surcharges separately stated to and collected from Airport Customers of the Company;
- 2) Any amounts received as insurance proceeds or otherwise for damage to

- vehicles or other property of the Company, or for loss, conversion, or abandonment of such vehicle;
- 3) Revenue from the disposal of salvage vehicles or the wholesale disposal or transfer of fleet vehicles;
  - 4) Amounts received as payment for and administration on behalf of customers of red light tickets, parking tickets, tolls, tows, and impound fees;
  - 5) All non-revenue rentals to employees of the Company; and
  - 6) The Customer Facility Charge.

Gross Revenues shall be determined by the total of charges on the face of the Airport Customer's receipt, less any charges specifically excluded in the definition of the term "Gross Revenues" above. Credits given to the Company's customers, including without limitation credits for out-of-pocket purchases of gas, oil, chains, tires, or emergency services, regardless of where made, may not be deducted by the Company from its Gross Revenues.

D. The City, acting by and through its Manager, may from time to time, at the Manager's sole discretion, and subject to the requirements of any outstanding bond ordinance pertaining to the Airport, reestablish the rentals, fees and charges provided for in this Section 6.2. The City agrees that in the event the Manager proposes or intends to make any such alteration, modification or change in the schedule of such fees, the Manager will give notice thereof to the Company not less than 90 days before the same is to become effective.

E. An amount equal to one-twelfth of the minimum annual guaranteed amount shall be payable by the Company commencing upon January 1, 2014 and thereafter on the first day of each succeeding month, in advance, during the term of this Agreement. In the event that 10% of the Company's Gross Revenues derived from its operations under this Agreement for any month during the term of this Agreement exceeds the portion of the minimum annual guaranteed amount for such month, an amount equal to such excess shall be payable by the Company on the 20th day of the next succeeding month. The Company agrees to furnish a true and correct statement of its Gross Revenues for the preceding month, signed by an authorized representative of the Company, to the Manager in a form acceptable to the City no later than the 20th day of the month immediately succeeding the date of occupancy as determined in this Section, and for each succeeding month during the term of this Agreement and the month immediately succeeding the expiration or termination of this Agreement.

F. Not later than 60 days following the end of each calendar year during the term of this Agreement, the amount of the Concession Fees payable by the Company to the City pursuant to this Section for the previous calendar year shall be determined as being the minimum annual guaranteed amount for such year or the annual percentage of Gross Revenues, whichever is greater. In the event that the correct amount of Concession Fees payable by the Company to the City for such year is the annual percentage of Gross Revenues and the total of the monthly percentage of Gross Revenues paid by the Company for such year is less than the annual

percentage of Gross Revenues, the amount of such deficiency shall be promptly paid by the Company to the City. In the event that the correct amount of Concession Fees payable by the Company to the City for such year is the annual percentage of Gross Revenues and the total of the monthly percentage of Gross Revenues paid by the Company for such year exceeds the annual percentage of Gross Revenues, the amount of such excess shall be credited against the obligation of the Company to pay Concession Fees under this Agreement or promptly repaid to the Company, as determined by the Manager in her sole discretion.

G. The Company shall make available within the City true and complete records and accounts of all Gross Revenues, including daily bank deposits, and not later than April 15<sup>th</sup> of each year shall furnish a true and accurate statement for the preceding year of the total of all such revenues and business transacted during such preceding calendar year showing the authorized deductions or exclusions in computing the amount of such Gross Revenues and business transactions, and including a breakdown of Gross Revenues on a month-by-month basis, which statement shall be certified by an authorized representative of the Company to be correct.

H. The Company agrees to establish and maintain a system of bookkeeping satisfactory to the City's Auditor and to give the City's authorized representatives access during reasonable hours to such books and records. Such system shall be kept in a manner as to allow the Airport operations hereunder to be distinguished from all other locations or operations of the Company. The Company agrees that it will keep and preserve for at least four years all sales slips, rental agreements, cash register tapes, electronic records, sales books, credit card invoices, bank books or duplicate deposit slips, and other evidence of Gross Revenues and business transacted which is routinely prepared, collected or compiled by the Company in the course of its business.

I. The Company's motor vehicle rental agreements shall be printed in such form as to allow its customers to designate on each agreement whether they have arrived at the Airport within a 24 hour period prior to signing the rental agreement or taking delivery of a rental motor vehicle and to allow its customer to sign verifying whether such arrival has taken place. The Company agrees it will require each of its customers to sign this portion of the rental agreement and further agrees any rental agreement which does not have a space upon it designating whether the customer so arrived at the Airport or which is not so signed by the customer shall be treated hereunder as though such customer arrived at the Airport within the previous 24 hours for purposes of computing compensation due to the City hereunder. A customer's designation on the form that he or she did not arrive at the Airport within the past 24 hours shall be verified by the customer presenting a valid, current Colorado driver's license showing a local address (Denver metropolitan area) and recording such address on the rental agreement. A customer's designation may also be verified by presenting a copy of a valid airline ticket receipt showing that the customer did not arrive at the Airport within the past 24 hours prior to the rental of the motor vehicle.

J. The Auditor of the City, the Manager, and their respective authorized

representatives shall have the right at any time and from time to time to audit all of the books of account, bank statements, documents, records, returns, papers, and files of the Company relating to its Gross Revenues and the performance by the Company of any other covenant and provision of this Agreement and the Company, upon the request by the Auditor or the Manager, shall make all such matters available for such examination within the Denver metropolitan area. If the City determines after an audit for any year that the Gross Revenues and business transacted shown by the Company's statement for such year was understated by more than three percent ( 3%), the Company shall pay to the City the amount of any deficiency, plus interest on such amount at the rate of 18% per annum from the date due.

K. The City's right to have such an audit made with respect to any year and the Company's obligation to retain the records described herein shall expire three years after the Company's annual statement for any year shall have been delivered to the City.

L. Notwithstanding the provision herein contained for the payment by the Company to the City of sums based upon a percentage of Gross Revenues, it is expressly understood and agreed that the City shall not be construed or held to be a partner, associate or joint venturer of the Company in the conduct of its business and the Company at all times shall have the status of an independent contractor for whose actions neither tort nor contractual liability shall be imposed upon the City.

M. The Company agrees that the Manager and the Auditor, and their authorized representatives, may inspect any sales tax return or report and accompanying schedules and data which the Company may file with the City pursuant to the City Retail Sales Tax Article, and the Company waives any claim of confidentiality which it may have in connection therewith.

**6.3. Place and Manner of Payments to the City.** All payments of Terminal Premises Rentals, Concession Fees, and other charges required to be paid by the Company to the City under this Agreement shall be made without demand or notice at the Office of the Director of Finance, Denver International Airport, Denver, Colorado or at such other place in the City as the Manager may hereafter designate by notice in writing to the Company, and shall be made in legal tender of the United States. Any check given to the City shall be received by the City subject to collection and the Company agrees to reimburse the City for any charges, fees or costs incurred by the City for such collection, including reasonable attorney's fees.

**6.4. Payments Under Agreement in Addition to Other Payments.** All amounts payable by the Company under this Agreement shall be in addition to amounts payable by the Company under the Facilities and Ground Lease Agreement dated January 1, 2014. All expenses incurred by the Company in connection with its operation and use of the Terminal Building Premises shall be paid by the Company directly without reduction of any other amounts payable by the Company under this Agreement, and without right of reimbursement.

**6.5. Pass Through of Concession Fees.** The Company acknowledges that the Concession Fee under this Agreement is not a fee that is imposed by the City upon airport customers renting vehicles from the Company. The City does not require, but shall not prohibit, the separate statement of the Concession Fee on Airport Customer invoices or rental contracts (“invoices”) provided that the Company meets all of the following conditions:

- A. Such fee shall be titled “Concession Recovery Fee” and shall not exceed 11.11% of all items of the Concession Fee on Airport Customer rental agreements;
- B. Such fee shall be indicated immediately below all items of the Concession Fee and not immediately adjacent to taxes on invoices;
- C. If the Company elects to designate a Concession Recovery Fee on invoices; the Company must comply with all applicable laws including Federal Trade Commission requirements;
- D. The Company shall not identify, treat or refer to the Concession Recovery Fee as a tax; and
- E. The Company shall not pass through, unbundle, or list as a separate item on its invoices any fees or charges payable to the City or the Airport (other than a Concession Recovery Fee and Customer Facility Charge), except with the City’s written approval.

**6.6. Rental Car Customer Facility Charge (CFC).**

A. The Airport intends to adopt and impose a Customer Facility Charge (“CFC”) on the Company’s Airport Customers on a per Rental Car Transaction Day basis, for the purpose of paying the costs and expenses associated with the management of, improvements to, and expansion of the existing rental car facility area and related transportation facilities and the planning and design of future phases of the rental car program or for any other rental car program related purpose as deemed appropriate by the Manager. The method of calculating the CFC and the amount of such CFC is determined by the Manager and implemented through an Airport Rule and Regulation.

B. The CFC shall apply to Airport Customer rental agreements commencing on or after January 1, 2014, and to all Rental Car Transaction Days for which a Usage Fee was not imposed and collected under the Company’s previous Special Facilities Lease expiring December 31, 2013. The Company shall list the CFC separately on the Airport Customer invoice, describing it as a “Customer Facility Charge”, and shall charge the fee per Rental Car Transaction Day in connection with each and every Airport Customer rental agreement entered into in connection with its operations on airport property in such manner and as directed by Airport Rule and Regulation.

C. The Company shall include the CFC in all forms of reservations not later than thirty (30) days prior to either the CFC charge effective date or the date on which a revised CFC



rate takes effect, provided Company is notified by the Airport of the CFC, or change in CFC, at least forty-five (45) days prior to charge effective date.

D. The CFC collected by the Company shall be deemed to be the property of the Airport and shall be held in trust by the Company for the benefit of the Airport. The Company agrees that the CFC is not income, revenue or any other asset to the Company; that the Company has no ownership or property interest in the CFCs; and that the Company hereby waives any claim to a possessory or ownership interest in the CFCs. The Airport (or the City Treasurer on its behalf) shall have complete possessory and ownership rights to the CFCs. The Company shall segregate, separately account for and disclose all CFCs as trust funds in its financial statements, and shall maintain adequate records that account for all CFCs charged and collected. Failure to segregate the CFCs shall not alter or eliminate their trust fund nature.

E. The Company shall remit all CFCs that were collected or should have been collected from its Airport Customers on a monthly basis to the Airport, together with a monthly statement of transactions which shall include Rental Car Transaction Days. CFCs shall be remitted to and received by the Airport no later than the 20<sup>th</sup> day of the month following the month in which the CFCs were or should have been collected. Failure to strictly comply with any portion of this Section shall be considered a material breach of this Agreement and the Company's authorization to do business on Airport Property.

F. The Company shall maintain adequate records, in full conformance with generally accepted accounting principles that account for all CFCs charged, collected and remitted. The City shall have the right to audit the CFC records upon reasonable notice to the Company.

G. The Company shall be entitled to no compensation for collection safe keeping and accounting of the CFC.

H. The CFC is not included in the definition of Gross Revenues.

#### **6.7. Obligations of Company Under Agreement Unconditional.**

A. The obligations of the Company to make the payments required hereunder and to perform and observe the other agreements on its part contained herein shall be absolute and unconditional and shall not be subject to any defense (other than payment) or any right of set off, counterclaim, abatement or otherwise and, until such time as this Agreement has been paid in full in accordance with Section 4.1 hereof, the Company:

(i) will not suspend or discontinue, or permit the suspension or discontinuance of, any payments required to be paid hereunder,

(ii) will perform and observe all of its other agreements contained in this Agreement.

B. Nothing contained in this Section 6.7 shall be construed to release the City from the

performance of any of the agreements on its part herein contained; and in the event the City shall fail to perform any such agreement on its part, the Company may institute such action against the City as the Company may deem necessary to compel performance, provided that no such action shall (i) violate the agreements on the part of the Company contained in the first paragraph of this Section 6.7 or (ii) diminish the payments and other amounts required to be paid by the Company hereunder. The Company may, however, at its own cost and expense and in its own name or in the name of the City (provided the City is a necessary party) prosecute or defend any action or proceeding or take any other action involving third persons which the Company deems reasonably necessary in order to secure or protect its rights hereunder with respect to the Terminal Building Premises, and in such event the City hereby agrees to cooperate fully with the Company and to take all action necessary to effect the substitution of the Company for the City in any such action or proceeding if the Company shall so request; provided that the City shall not be required to take any act which, in the opinion of the City Attorney, would be prejudicial to the rights or interests of the City in connection with such action or proceeding or the facts giving rise thereto.

C. In the event the Company shall fail to make any of the payments required hereunder, the payment so in default shall continue as an obligation of the Company until the amount in default shall have been fully paid and the Company will pay interest on such amount at the rate of 18% per annum.

## **SECTION 7 SPECIAL COVENANTS**

**7.1. Financial Statements of Company.** The Company agrees to furnish to the Manager within 120 days after the end of each fiscal year of the Company, a copy of the financial statements of the Company for such fiscal year, audited by the Company's regular independent certified public accountant; provided, however, that in the event that the Company's financial statements for such fiscal year are not audited by an independent certified public accountant, such financial statements shall be reviewed by an independent certified public accountant. The City agrees to treat such financial statements as confidential information.

**7.2. Company to Maintain its Corporate Existence.** The Company agrees that during the term of this Agreement it will maintain in good standing its corporate existence, will remain duly qualified to do business in the State, will not dissolve or otherwise dispose of all or substantially all of its assets and will not consolidate with or merge into another corporation; provided, however, that the Company may, without violating the agreement contained in this Section 7.2, consolidate with or merge into another corporation either incorporated and existing under the laws of the State or qualified to do business in the State as a foreign corporation, or sell or otherwise transfer to another such corporation all or substantially all of its assets as an entirety and thereafter dissolve, provided (i) the resulting, surviving or transferee corporation, as the case may be, is not "insolvent" within the meaning of the Colorado Uniform Commercial Code, (ii) the resulting, surviving, or transferee corporation has not ceased to pay its debts in the ordinary course

of business and can pay its debts as they become due and is not insolvent within the meaning of the federal bankruptcy law, and (iii) the resulting, surviving or transferee corporation irrevocably and unconditionally assumes in writing and agrees to perform by means of an instrument which is delivered to the Manager, all of the obligations of the Company herein.

### **7.3. Defense and Indemnification.**

A. The Company shall pay, and shall protect, defend, indemnify and save the City and its agents, officers and employees harmless from and against any and all liabilities, losses, damages, costs, and expenses (including attorneys' fees and expenses of the Company and the City, causes of action, suits, claims, demands, and judgments of whatsoever kind and nature (including those arising or resulting from any injury to or death of any person or damage to property) arising out of any of the following except when caused by the willful misconduct or gross negligence of the City or its respective agents, officers, or employees: (i) the Company's operations in connection with this Agreement or the Company's use or occupancy of the Terminal Building Premises or any other portion of the Airport (ii) the provision or failure to provide security as herein required, (iii) violation by the Company of any agreement, representation, warranty, covenant, or condition of this Agreement; (iv) violation by the Company of any other contract, agreement, or restriction relating to the Terminal Building Premises; or (v) violation by the Company of any law, ordinance, regulation, or court order affecting the Terminal Building Premises or the ownership, occupancy or use thereof.

B. The Company shall pay, and shall protect, defend, indemnify, and save the City and its agents, officers and employees harmless from and against any and all liabilities, losses, damages, costs and expenses (including attorneys' fees and expenses of the Company and the City), causes of action, suits, claims, demands, and judgments of whatsoever kind and nature in connection with the Company's operations hereunder arising out of, based upon or related to any federal, State or local antitrust or trade regulation statute, ordinance, rule or regulation, as may from time to time be in effect, including but not limited to federal laws such as the Sherman Antitrust Act, 15 U.S.C. §§ 1-7, the Clayton Act, as amended by the Robinson Patman Act, 15 U.S.C. §§ 12-27, and the Federal Trade Commission Act, 15 U.S.C. §§41-58, and any State antitrust or trade regulation statute, rule and regulation.

C. The Company will defend any and all claims which may be brought or threatened against City and will pay on behalf of City any expenses incurred by reason of such claims including, but not limited to, court costs and attorney fees incurred in defending and investigating such claims or seeking to enforce this indemnity obligation, provided however, the City shall promptly notify the Company in writing of any claim or action brought against the City in respect of which indemnity may be sought against the Company. Such payments on behalf of City shall be in addition to any other legal remedies available to City and shall not be considered City's exclusive remedy.

D. This defense and indemnification obligation shall survive the expiration or termination of this Agreement.

**7.4. Taxes on Amounts Payable by City.** In the event that any taxes, assessments, payments in lieu of taxes, or other charges are levied on the City with respect to any amount to be paid hereunder, the Company agrees to pay the same promptly and to hold the City harmless. In the event the Company shall pay any such tax, assessment, or other charge, the Company shall be subrogated to the City's right, if any, to contest the validity of the levy of such tax, assessment, or other charge and shall be entitled to recovery from the parties to whom the same was paid, as compensatory damages, of an amount up to the amount of such tax, assessment, or other charge so paid by the Company plus, to the extent permitted by law, the amount of legal fees incurred in connection with such contest.

**7.5. Quiet Enjoyment.** The City covenants that the Company, on performing its covenants and other obligations hereunder, shall have quiet and peaceable possession of the Terminal Building Premises from the completion of the Terminal Building Premises and their acceptance for occupancy by the Company to the termination of the Agreement.

**7.6. Patents and Trademarks.** The Company covenants that it is the owner of or fully authorized to use any and all services, processes, machines, articles, marks, names, or slogans to be used by it in its operations under, or in any way connected with this Agreement. The Company agrees to save and hold the City, its City Council, and its officers, employees, agents, and representatives free and harmless of and from any loss, liability, expense, cost, suit or claim for damages in connection with any actual or alleged infringement of any patent, trademark, or copyright arising from any alleged or actual unfair competition or other similar claim arising out of the operation of the Company under or relating to this Agreement.

**7.7. Assignments and Subleases by Company.** Except as otherwise provided in Section 7.2 hereof, the Company shall not assign or otherwise transfer its interest in this Agreement, in whole or in part, or any right or leasehold interest or interests granted to it by this Agreement, or sublet or otherwise transfer any interest in or to the Terminal Building Premises, without the prior written consent of the Manager in her sole discretion.

**7.8. Performance Bond.**

A. Upon the commencement of the terms of this Agreement, the Company shall deliver to the Manager, and shall maintain in effect at all times during the term of this Agreement, including a period of six months after expiration or earlier termination of this Agreement, a valid corporate performance or surety bond or an irrevocable letter of credit, in an amount equal to three (3) months of Terminal Premises Rentals and three (3) months of the minimum annual guaranteed amount required by Section 6.2B hereof, payable without condition to the City, with surety acceptable to and approved by the Manager, which bond or irrevocable letter of credit shall

guarantee to the City full and faithful performance of the terms and provisions of this Agreement.

B. Notwithstanding the foregoing, if at any time during the term hereof, the Manager deems the amount of the surety insufficient to properly protect the City from loss hereunder because the Company is or has been in arrears with respect to such obligations or because the Company has, in the judgment of the Manager, violated other terms of this Agreement, the Company agrees that it will, after receipt of notice, increase the surety to an amount required by the Manager.

**7.9. Agreements with United States of America.** This Agreement is subject and subordinate to the terms, reservations, restrictions, and conditions of any existing or future agreements between the City and the United States of America, the execution of which has been or may be required as a condition precedent to the transfer of federal rights or property to the City for airport purposes or for the expenditure of federal funds for the extension, expansion or development of the Airport including the provisions of Appendix 1 which is incorporated herein by reference.

**7.10. Master Plan for Airport.** The Company agrees that no liability shall attach to the City, its officers, agents and employees by reason of any efforts or action toward implementation of any present or future master plan for the development or expansion of the Airport, and for and in consideration of the granting of the rights and privileges herein granted, the Company waives any right to claim damages or other consideration arising therefrom.

**7.11. Disadvantaged Business Enterprises.**

A. The Company agrees that it shall provide, in the manner set forth in subsection B of this Section 7.11, for at least two percent (2%) participation by certified Airport Concession Disadvantaged Business Enterprises (ACDBEs), as defined in 49 C.F.R., Part 23, as joint venturers, subtenants, or as providers of goods and services used in business conducted at the Airport under this Agreement, or in the form of any legal arrangement meeting the eligibility standards in 49 C.F.R. Part 23, as it may be amended from time to time, such percentage amount of participation being a percentage of the annual Gross Revenues obtained by the Company in its operations hereunder. Throughout the term of this Agreement, the Company shall continue to utilize qualified and available ACDBE firms which have been and which continue to be certified by the City to the fullest extent which is reasonably possible to achieve and to an extent necessary to comply with the percentage of participation for ACDBEs set forth in this Section 7.11. If an ACDBE subtenant, joint venturer, supplier, or service provider must be replaced for any reason during the term of this Agreement, the Company agrees to replace the subtenant, joint venturer, supplier, or service provider with another ACDBE, or if it cannot, then the Company shall demonstrate that it made good faith efforts to do so.

B. The Company shall be required to comply with other appropriate provisions of 49

C.F.R. Part 23 implementing Section 511(h) of the Airport and Airway Improvement Act of 1982, as amended.

C. Concessionaire agrees to comply with Federal, State and Local Disadvantaged Business programs as more fully set forth in **Appendix 1, Standard Federal Assurances and Nondiscrimination; Exhibit C, ACDBE Commitment Form; and Exhibit X.** Concessionaire further agrees to submit any report(s) or information that the City is required by law or regulation to obtain from Concessionaire.

**7.12. Concession Agreements with other Car Rental Companies.** The City agrees that during the Term of this Agreement it will not enter into a Concession Agreement with another car rental company which provides for terms and conditions more favorable than those contained herein unless the same terms and conditions are offered to the Company.

## **SECTION 8 USE AND MAINTENANCE OF FACILITIES**

**8.1. Permitted Use.** The City hereby grants to the Company the right to occupy and use the portions of the Airport constituting the Terminal Building Premises, together with necessary rights of ingress and egress, for the sole purpose of operating at the Airport a non-exclusive concession for the rental of motor vehicles to the public. The Company, with the approval of the Manager, shall be permitted to use the Terminal Building Premises for any additional use which constitutes a proper airport purpose and which is permitted by Section 802 of the General Airport Bond Ordinance.

**8.2. Limitations Upon Use and Location.** The Company agrees that it will not sell or undertake any activity in connection with the retail sale of used motor vehicles at the Airport. The Company shall not install any display or device upon the Terminal Building Premises which in any way obstructs the public view of any of the other Companies or any of the other concessionaires of the Airport. The Company shall not commit waste with respect to the Terminal Building Premises and shall not commit or permit any nuisance from or upon the Terminal Building Premises. The Company agrees to keep the Terminal Building Premises in a neat, clean, safe, sanitary and orderly condition at all times, to keep the Terminal Building Premises free at all times of all paper, rubbish and debris, and to deposit all trash and debris at locations approved by the Manager.

### **8.3. Compliance with Municipal Regulations.**

A. The Company shall comply with and shall cause its officers and employees and any other persons over whom it has control to comply with such reasonable rules and regulations governing the use of the Terminal Building Premises and any other portion of the Airport as may from time to time be adopted and promulgated by the City for the management, operation and

control of the Airport either promulgated by the City on its own initiative or in compliance with regulations or actions of a federal agency authorized to regulate interstate flights to or from the Airport; provided, however, such rules and regulations shall not be inconsistent with the rights herein granted to the Company; and provided, further, that nothing herein shall be considered to restrict the police power of the City.

B. Company agrees not to use or permit the Terminal Building Premises to be used for any purpose prohibited by the laws of the United States or the State of Colorado or the ordinances or Charter of the City and County of Denver, or not authorized hereunder, and it further agrees that it will use the Terminal Building Premises in accordance with all applicable federal, state, and local laws and all general rules and regulations adopted by the City or the Manager for the management, operation, and control of the Airport, either promulgated by the City on its own initiative or in compliance with regulations, requirements, or actions of the Federal Aviation Administration or other authorized federal agency. Company further agrees to submit any report or reports or information which the City is required by law or regulation to obtain from Company or which the Manager may reasonably request relating to Company's operations.

C. **Prevailing Wage.** To the extent required by Section 20-76 of the Denver Revised Municipal Code, Company shall require its contractors and all of its subcontractors and subtenants to pay every worker, laborer, or mechanic employed by them in the performance of any construction of improvements on the Terminal Building Premises the prevailing wages, including fringe benefits or their cash equivalent, for the same class and kind of work in the City and County of Denver, as determined by the Career Service Board under the provisions of Section 20-76 of the Denver Revised Municipal Code. The wages shall be those prevailing at the time of the contractor's final bid, and Company shall require the contractor to submit with its bid the wage schedule applicable. The contractor shall post in a prominent and easily accessible place at the site of the improvements the scale of wages to be paid by the contractor and all subcontractors at any tier working under the contractor. The contractor shall furnish to the Auditor or his authorized representative, each week during which work is in progress, a true and correct copy of the payroll records of all workers employed to perform the work. All payroll records shall include information showing the number of hours worked by each worker, the hourly pay of such worker, any deductions made from pay, and the net amount of pay received by such worker for the period covered by the payroll. The payroll record shall be accompanied by a sworn statement concerning the records of all workers performing the work, either for the contractors or subcontractors, that payments were made to the workers as set forth in the payroll records, that no deductions were made other than those set forth in such records, and that all workers were paid the prevailing wages as of the contractor's final bid for the work. Compliance with above requirements shall be deemed a work "specification" as such word is used in Section 49-173, Denver Revised Municipal Code. Violation of the prevailing wage requirement and its documentation, herein above set forth, shall result in an order from the Manager of Aviation for the work to cease until there is satisfactory evidence that the violation has been remedied and will not recur. The issuance of a stop-work order shall not relieve the contractor's surety of any liability on the contractor's bond or

bonds, but such a stop-work order shall be deemed a default by the contractor insofar as said surety's obligation is concerned.

D. **Division of Small Business Opportunity.** To the extent permitted by Divisions 1 and 3 of Article III of Chapter 28 of the City's Revised Municipal Code and the MBE and WBE Program's Rules and Regulations, the Director of the Division of Small Business Opportunity ("DSBO") will review the employment practices of Company's contractors and all levels of subcontractors and suppliers, and the utilization by the contractors of Minority and Women Business Enterprises ("MBE and WBE") and/or Disadvantaged Business Enterprises ("DBE"), in connection with work performed on the Terminal Building Premises. The reviews will be made to determine whether or not all applicable rules, regulations, ordinances, and laws governing equal employment opportunity, affirmative action programs, and MBE, WBE and DBE requirements are complied with. Company acknowledges its continuing duty, pursuant to Denver's MBE and WBE Ordinances, to maintain throughout the duration of the Construction Period compliance with the level of participation upon which the City approved the award of this Agreement to the Company.

**8.4. Bond Ordinances.** This Agreement is in all respects subject and subordinate to any and all the City bond ordinances applicable to the Airport and airport system and to any other bond ordinances which should amend, supplement or replace such bond ordinances. The parties to this Agreement acknowledge and agree that all property subject to this Agreement which was financed by the net proceeds of tax-exempt bonds is owned by the City, and the Company agrees not to take any action that would impair, or omit to take any action required to confirm, the treatment of such property as owned by the City for purposes of Section 142(b) of the Internal Revenue Code of 1986, as amended. In particular, the Company agrees to make, and hereby makes, an irrevocable election (binding on itself and all successors in interest under this Agreement) not to claim depreciation or an investment credit with respect to any property subject to this Agreement which was financed by the net proceeds of tax-exempt bonds and shall execute such forms and take such other action as the City may request in order to implement such election.

**8.5. Compliance with Other Governmental Regulations.** The Company shall, at all times, faithfully obey and comply with all existing and future laws, rules, and regulations adopted by Federal, State, local or other governmental bodies and applicable to or affecting the Company and its operations and activities in and at the Airport, including without limitation the Terminal Building Premises, provided, however, that the Company may, without being considered to be in breach of this Agreement, contest any such laws, rules, and regulations so long as such contest is diligently commenced and prosecuted.

**8.6. Utilities.**

A. The City agrees to furnish, at its sole expense, normal illumination, heat, ventilation, and air conditioning for the areas made available to the Company hereunder in the Terminal at the Airport. The City, at its sole expense, shall construct, install and maintain, or have



constructed, installed and maintained, adjacent to the Terminal Building Premises telecommunications conduit and draw strings, universal data jacks, convenience outlets, and electrical boxes within counters sufficient for the purposes of the Company pursuant to this Agreement.

B. The Company shall provide and maintain, at its sole expense, such telecommunications equipment, monitored circuit breakers, and services as it may deem necessary for its operations at the Terminal Building Premises.

### **8.7. Company Property.**

A. The Company may from time to time, in its sole discretion and at its own expense, install machinery, equipment, and other personal property on or upon the Terminal Building Premises. All such personal property so installed by the Company shall remain the sole property of the Company in which the City shall have no interest except as otherwise provided herein.

B. Notwithstanding anything herein to the contrary, any personal property installed by the Company pursuant to this Section 8.7 shall constitute Terminal Building Premises rather than property of the Company if such property is so affixed to the Terminal Building Premises so as to be classified as a fixture under applicable law. The Company shall have the right at any time during the term of this Agreement, when not in default hereunder, to remove any or all of the property installed by the Company pursuant to this Section 8.7, at its own expense, subject to the Company's obligation to repair, at its own expense, all damage, if any, resulting from such removal.

**8.8. Disposition of Company Property at End of Agreement Term.** All property installed by the Company pursuant to Section 8.7 hereof shall be removed by the Company at its own expense by the expiration or earlier termination of the term of the Agreement.

**8.9. Repairs, Maintenance and Replacement.** The Company covenants and agrees at its expense, and without cost or expense to the City, during the term hereof, after the occupancy of the Terminal Building Premises:

- A. that the Company shall keep the Terminal Building Premises in good order and condition and will make all necessary and appropriate repairs and replacements thereof;
- B. that the Company shall not permit rubbish, debris, waste materials, or anything unsightly or detrimental to health, or likely to create a fire hazard, or conducive to deterioration, to remain on any part of the Terminal Building Premises or to be disposed of improperly; and
- C. that the Company shall at all times maintain the Terminal Building Premises in accordance with all applicable codes, rules and regulations of the City, as they may be amended or otherwise modified from time to time.

**8.10. Right to Enter, Inspect and Make Repairs.** The City and its authorized officers, employees, agents, contractors, subcontractors, and other representatives shall have the right (at such times as may be reasonable under the circumstances and with reasonable notice to the Company and with as little interruption of the Company's operations as is reasonably practicable) to enter upon the Terminal Building Premises for the following purposes:

A. to inspect such premises at reasonable intervals during regular business hours (or at any time in case of emergency) to determine whether the Company has complied and is complying with the terms and conditions of this Agreement with respect to such premises;

B. to perform periodic maintenance and make repairs and replacements in any case where the Company is obligated but has failed to do so, after the City has given the Company reasonable notice so to do, in which event the Company shall reimburse the City for the reasonable cost thereof promptly upon demand; and

C. to do any and all things which the City deems necessary for the proper general conduct, security, and operation of the Airport or in the proper exercise of the City's police power; provided, however, that nothing contained in this Section 8.10 shall limit the power of the City and its authorized officers, employees, and agents to enter upon the Terminal Building Premises as provided by law in a capacity other than as lessor under this Agreement. No such entry by or on behalf of the City upon the Terminal Building Premises shall cause or constitute a termination of the Agreement or be deemed to constitute an interference with the possession thereof by the Company.

**8.11. Signs.** The Company agrees that no signs, marquees, or advertising displays shall be painted on or erected in any manner upon the Terminal Building Premises or any other portion of the Airport without the prior written approval of the Manager; and that signs identifying the Company will conform to reasonable design standards established by the Manager, with respect to type, quantity, size, mounting, height, color, design, and location. Subject to such limitations and the prior approval by the Manager, the Company may paint or erect such sign or signs reasonably necessary to identify the Company.

**8.12. Vending Machines.** No amusement or vending machines or other machines operated by coins or tokens shall be installed or maintained in or upon the Terminal Building Premises except with the prior permission of the Company and the City and the number, type, kind and locations thereof shall be in the discretion of the Manager and the Company. Except as otherwise provided in this Section 8.12, the Company shall not permit the installation of any such machines, except by a concessionaire authorized by the Manager and subject to and in accordance with such concessionaire's agreement with the City. The Company shall make no charge to the concessionaire for the privilege of installing or maintaining such machines (except that if the Company provides any electric current or water to the concessionaire a reasonable charge may be made to recover the cost of the electricity and water consumed), and all fees paid by the

concessionaire for that privilege shall be deposited in the Revenue Fund under the General Airport Bond Ordinance. If there is no concessionaire authorized by the City who is willing to install the number, type and kind of machines desired by the Company, and the Company finds some other person who is willing and able so to do, then at the written request of the Company the Manager shall authorize such other person as a concessionaire to do so, provided that such other person shall enter into the City's usual concession agreement for that type of installation, and provided further that no existing contractual agreements of the City are violated thereby.

**8.13. Purchases by Company.** Property, services and materials (except as otherwise provided in this Agreement) may be purchased or otherwise obtained by the Company from any person or corporation of its choice and no unjust or unreasonable discriminatory limitations, restrictions, charges, or conditions shall be imposed by the City, directly or indirectly, against the Company or its suppliers for the privilege of purchasing, selling, using, storing, withdrawing, handling, consuming, loading, unloading, or delivering any personal property of the Company, by the Company or its suppliers, or for the privilege of transporting such personal property to, from or on the Terminal Building Premises.

**8.14. Sale of Food and Beverages.** The Company shall not sell or permit the sale of food, food products, or beverages, both alcoholic and non-alcoholic, upon the Terminal Building Premises except by a concessionaire to whom the City has granted the right to provide such services on the Terminal Building Premises.

**8.15. Use, Possession, or Sale of Alcohol or Drugs.** The Company and its officers, agents and employees shall cooperate and comply with the provisions of the Federal Drug-Free Workplace Act and Denver Executive Order No. 94 and all attachments thereto, as amended from time to time, or a successor executive order, concerning the use, possession or sale of alcohol or drugs. Violation of these provisions or refusal to cooperate with implementation of the policy can result in the City's barring the Company from City facilities or participating in City operations.

**8.16. City Smoking Policy.** The Company and its officers, agents and employees shall cooperate and comply with the provisions of Colorado Indoor Clean Air Act and Denver Executive Order 99, as they may be amended from time to time, or a successor executive order, prohibiting smoking in all indoor buildings and facilities. The Company agrees to prohibit smoking by its employees and the public on the Terminal Building Premises.

**8.17. Security.**

A. It is understood and agreed by the Company that in addition to the Company's responsibilities to maintain the Terminal Building Premises as provided herein, it shall take reasonable security precautions to maintain the Terminal Building Premises in a manner as to keep it secure from unauthorized intrusion.

B. It is further understood and agreed by the Company that at any time during the term hereof when requested in writing by the Manager, the Company shall submit to the Manager the security plans that are to be used and are being used by the Company on any or all of the Terminal Building Premises.

**8.18. Operations.** The Company agrees to operate its motor vehicle rental business at the Airport for the accommodation of its customers using the Airport, and to operate the Facilities in the following manner:

A. The Company shall furnish all personnel, equipment, inventory, and supplies necessary to operate its motor vehicle rental business at the Airport.

B. The Company shall at all times retain at the Airport an experienced manager fully authorized to represent and act for it in all matters pertaining to the operation of its motor vehicle rental business at the Airport. At such times as such manager is not present at the Airport, the Company shall assign, or cause to be assigned, a qualified subordinate to be in charge of the Company's locations, services and facilities at the Airport and to be available at such locations and to act for such manager.

C. The Company agrees that, at its own expense, it will maintain the motor vehicles used in its motor vehicle rental business at the Airport in good operating order and repair and free from known mechanical defects; that it will not rent to any person any motor vehicle which is not in good operating order and repair, or which may be hazardous to the person renting such motor vehicle or to the general public; that all rental motor vehicles shall be kept in a clean, neat, and attractive condition inside and out; that its rental motor vehicles will be late model equipment no more than two years older than current year model for each vehicle type provided; and that it will at its own expense provide a sufficient number of rental motor vehicles to properly meet the reasonable public demand therefore.

D. All Shuttle Vehicles used by the Company to transport its customers between the Facilities and the curbside at the Terminal Building at the Airport shall comply with the following requirements in addition to any other applicable regulatory requirements set forth in this Agreement. A Shuttle Vehicle may be subject to revocation of its AVI tag issued pursuant to Section 8.19 for default of the following requirements, provided the City has given 30 days' prior written notice of default and the Company has failed to either cure the default or commence corrective action within said 30 days.

Definitions:

- (i) "Alternative Fuel" shall mean compressed natural gas, liquid natural gas under specific conditions mandated by the Denver Fire Department, methanol, electric (battery), biodiesel (B5 or higher), and such other alternative fuels acceptable to the

Manager which may hereafter be proposed by the Company to the City.

- (ii) “Commercially Unavailable”, as used in this Section 8.18D, shall mean when a Shuttle Vehicle using an Alternative Fuel, or meeting Ultra Low Emission Vehicle (ULEV) standards, as applicable: a) has an initial capital cost exceeding 20% of the capital cost for a comparable Shuttle Vehicle or engine preferred by the Company, including any rebates, credits, refunds, and offsets from federal, state, or local governments, b) has a per annum maintenance cost exceeding 20% of the maintenance cost for a comparable Shuttle Vehicle or engine preferred by the Company, based on using the manufacturers’ recommended maintenance practices for the three most recent years, c) cannot be delivered until more than 60 days beyond the delivery date for a comparable Shuttle Vehicle or engine preferred by the Company, or d) requires fuel which is not readily available within 5 miles of the Facilities.
  
- (iii) The term "Shuttle Vehicles," as used in this Section 8.18D, shall mean Buses, Vans and Cutaways or other similar vehicles used to transport car rental customers between the Terminal and the Facilities. "Buses," as used in this Section 8.18D, shall mean fully designed OEM vehicles designed exclusively to transport passengers, by the manufacturers, with a minimum gross vehicle weight rating (GVWR) of 16,000 pounds. "Large Buses" shall mean Buses with a minimum gross vehicle rating (GVWR) of 26,000 pounds. "Vans," as used in this Section 8.18D, shall mean OEM vehicles unmodified in length with a GVWR not exceeding 9,300 pounds, which may include vehicles with a modified raised roof. The term "Cutaways," as used in this Section 8.18D, shall mean vehicles with an OEM chassis with a traditional cab on which a custom body is installed with the intent of being a people mover, with a GVWR not exceeding 13,500 pounds. Further, for purposes of determining Commercial Unavailability, "Shuttle Vehicle" shall mean a vehicle meeting the reasonable specifications of the Company, including specifications pertaining to size, chassis, and passenger access, at the time of vehicle or engine replacement.

After January 1, 2002, unless otherwise waived by the Manager, all Shuttle Vehicles, or engine replacements that occur after the end of useful life of the vehicle (which shall be the manufacturer-designated life, if applicable), at the time a binding order must be made for vehicle or engine replacement in the ordinary course of business, must be replaced by new vehicles or replacement engines using an Alternative Fuel or failing that, new vehicles or replacement engines meeting Ultra Low Emission Vehicle (ULEV) standards. A waiver by the Manager shall be made per vehicle. The basis for the waiver shall be Commercial Unavailability as defined above. The burden of proof shall be on the Company to first demonstrate to the Manager’s reasonable satisfaction Commercial Unavailability of Alternative Fuel and ULEV-compliant vehicles or engines. Evidence shall include third-party verification of unavailability.

The Shuttle Vehicles shall comply with applicable requirements set forth in the Environmental Guidelines for Tenant Operations at Denver International Airport and the Ground Transportation Rules and Regulations for Denver International Airport, as they may be amended from time to time. Shuttle Vehicles shall be maintained in accordance with the manufacturer's recommended maintenance schedules.

The City reserves the right in its sole discretion to limit the number of Shuttle Vehicle trips, dwell times at the curbside of the Terminal Building and Shuttle Vehicle idling time based upon air quality monitoring by the City and the Denver International Airport Environmental Guidelines for Tenant Operations.

E. The Company agrees that it will keep its motor vehicle rental counters at the Airport open for public business with adequate staffing from at least 7:00 A.M. until 10:00 P.M. each day of the year. The Company's employees shall be clean, courteous, efficient, and neat in appearance. The Company shall not allow employees in or about the Terminal Building Premises to use improper language or to act in a loud or boisterous or otherwise improper manner.

F. The Company shall properly uniform its attendants. Attendants shall discharge their duties in a courteous and efficient manner and it shall be the duty of the Company to maintain a high standard of service by its attendants to the public to the satisfaction of the Manager in her sole discretion.

G. The Company shall not use curbside drop-off and pick-up areas at the Airport designated by the City for passenger use for valet drop-off and pick-up of rental motor vehicles.

H. The Company agrees to submit any reports or information regarding its operations that the Manager may reasonably request. The City agrees to treat such reports and information as confidential information.

I. The Company agrees not to refuse to hire, discharge, promote or demote, or to discriminate in matters of compensation against any person otherwise qualified, solely because of race, color, religion, national origin, gender, age, military status, sexual orientation, marital status or physical or mental disability.

J. The Company agrees that at the Terminal counter it will provide informational services only, using no more than one customer service representative for each four feet of counter width. The Company will complete its rental transactions, including but not limited to preparation and signing of rental contracts and exchange of money, credit cards or other legal tender, at the property leased under the Facilities Lease. The parties agree that breach of this paragraph J shall be an event of default if written notice specifying such breach is served upon the Company and the Company fails to cure within 30 days of receiving the notice. Further, should such event of default occur and be

continuing, the City shall have the right, at the City's election, to exercise the following remedy: prohibit the Company from utilizing counter representatives and require the Company to limit its occupancy and use of the Terminal counter to a reservations display and direct or recorded telephone connection only.

K. The Company agrees to have behind the counter no more than one customer service representative for each four feet of counter width, but may assign an additional representative in front of the counter if necessary to reduce queues. If the Manager determines that the Company's queues are impeding pedestrian traffic, she may require reasonable and appropriate operational changes, including but not limited to an additional representative in front of the counter.

### **8.19 Commercial Roadway Access**

A. The company agrees it shall not operate its commercial vehicles, other than its rental motor vehicles rented to its customers for their exclusive use, upon Airport premises without first obtaining an Automated Vehicle Identification Tag ("AVI Tag") for each vehicle in its fleet, which AVI Tag shall be affixed to the vehicle and used by the Company when accessing commercial roadways designated for passenger loading and unloading. To obtain AVI Tags, the Company shall submit an application to the City on the form provided by the City. AVI Tags obtained from the E-470 Authority may also be registered with the City for access to the Airport.

B. A refundable deposit will be assessed by the City for each AVI Tag issued to the Company by the City. The AVI Tag fee is subject to change. The company agrees to submit a description of the passenger carrying capacity (including the driver), as established by the vehicle manufacturer, of each commercial vehicle for which access to the Airport is desired; the vehicle identification number for each vehicle; the license plate number for each vehicle; applicable insurance documentation as required herein for each commercial vehicle for which an AVI Tag is desired; and such other information as may be required by the City.

C. AVI Tags are not transferable to any vehicles other than the ones to which they are originally assigned. The Company agrees that it is solely responsible for any unauthorized use of AVI Tags registered to its vehicles. The Company agrees that it is solely responsible for training of its staff and for the use of and accountability for all AVI Tags issued to the Company. The Company also agrees that in the event its AVI Tags may be used by some other person, company or entity without authorization, the Company is responsible and liable to the City for all fees charges for the use of its AVI Tags for trips of vehicles through the Airport roadway facilities prior to the time the Company notifies the City of the loss or theft of its AVI Tag. The Company further agrees that all AVI Tags issued to it by the City remain the property of the City and that misuse of such AVI Tags will constitute a default under the terms of this Agreement which if not cured may result in termination of this Agreement, following which the said AVI Tags will be deactivated and shall be returned to the City or the deposit thereon will be forfeited by the Company. AVI tags obtained from E-470 do not qualify to be returned to the City.

**SECTION 9**  
**LOSS OF AND LIABILITIES PERTAINING TO**  
**TERMINAL BUILDING PREMISES**

**9.1. Property Insurance.** At all times during the term of this Agreement, the Company agrees that, at its own cost and expense, it shall keep the Terminal Improvements insured against loss or damage (in excess of \$50,000 in any one occurrence) by fire, lightning, tornado, windstorm, hail, flood, earthquake, explosion, riot, riot attending a strike, civil commotion, vandalism and malicious mischief, sprinkler leakage, aircraft, vehicles and smoke, or any other casualty, in amounts not less than 100% of the replacement value of such improvements. The replacement value of the Terminal Improvements shall be re-established at intervals of not more than three (3) years, commencing on the date of commencing operations on the Terminal Building Premises by an independent qualified appraiser, employed by the Company and approved by the Manager.

**9.2. Liability Insurance.**

A. The Company agrees, at its own cost and expense, to provide and keep in force for the benefit of the Company and the City, a policy, or policies, of General Liability Insurance written on a single limit each occurrence basis with limits of not less than \$2,000,000 for bodily injury and property damage arising from any operation of the Company at the Airport and including contractual liability coverage.

B. The Company agrees, at its own cost and expense, to provide and keep in force for the benefit of the Company and the City, Comprehensive Automobile Liability Insurance. This insurance shall cover owned, hired, and non-owned vehicles against death, bodily injury, and property damage claims, in a combined single limit amount of not less than \$2,000,000.

C. The Company agrees, at its own cost and expense, to maintain environmental impairment liability insurance as may now or hereafter be required by any applicable local, state or federal laws, rules or regulations to cover loss, leakage or spillage of fuel or gasoline products, chemical solvents or hazardous materials referred to in the Denver International Airport Environmental Guidelines for Tenant Operations.

**9.3. Payment of Insurance Proceeds.** All property insurance policies obtained pursuant to Sections 9.1 and 9.2 hereof shall provide for payment of the proceeds to the City and the Company, as their respective interests may appear.

**9.4. Continued Obligation to Pay Rentals.** No loss or damage, regardless of whether it is wholly or partially insured, shall in any way relieve the Company of its obligation to make payments as provided in Section 6 hereof.



**9.5. Limitations as to Policies.** The insurance policy, or policies, and certificates of insurance evidencing the existence thereof required by Sections 9.1 and 9.2 hereof shall be in a form and written by a company, or companies, approved by the Manager and shall insure the Company's agreement to indemnify the City as set forth in the indemnification provisions hereof; provided, however, that the City, in the sole discretion of the Manager, may permit the Company to self insure for all or a portion of the insurance otherwise required by Sections 9.1 and 9.2 hereof. The City shall not be a named insured of any insurance required by Sections 9.1 and 9.2 hereof. All such certificates of insurance, and all certificates of self insurance permitted by the City shall be delivered by the Company to the Manager. The Company shall deliver to the Manager any renewal certificates for such insurance at least 15 days prior to the expiration of any such policies. The City agrees to treat such, certificates of insurance, or certificates of self insurance as confidential information.

**9.6. Failure of Company to Provide Insurance.** If at any time the Company shall fail or neglect to insure the Terminal Improvements, as aforesaid, or to deliver such policies or certificates as aforesaid, the City may effect such insurance by obtaining policies issued by companies satisfactory to the City. The amount of the premium or premiums paid for such insurance by the City shall be payable by the Company to the City with the installment of rent thereafter next due under the terms of this Agreement, with interest thereon at the rate of 18% per annum from the date of payment of such premium or premiums by the City to the date of such reimbursement by the Company. The City shall not be limited in the proof of any damage which the City may claim against the Company arising out of or by reason of the Company's failure to provide and keep in force insurance as aforesaid, to the amount of the insurance premium or premiums not paid or incurred by the Company and which would have been payable upon such insurance, but the City shall also be entitled to recover as damages for such breach the uninsured amount of any loss, damages, cost and expenses of suit suffered or incurred by reason of damage to, or destruction of, or liability appertaining to, the Terminal Building Premises occurring during any period when Company shall have failed or neglected to provide insurance as aforesaid.

**9.7. Notification of Loss and Compliance with Policies.** The Company shall not violate the terms or prohibitions of any insurance policy herein required to be furnished by the Company, and the Company shall promptly notify the City of any claim or loss under such insurance policies. The City shall not be under any obligation to prosecute, settle or adjust any claim which may accrue under any policy of insurance required herein lodged with the City, or to give any notice to the insurance company, except in regard to liability insurance, but the City shall give notice in all cases to the Company as provided in Section 7.3 hereof.

## **SECTION 10 LIENS AND CLAIMS**

**10.1. Prompt Payment of Taxes and Fees.** The Company covenants and agrees to pay promptly all lawful taxes, including social security and unemployment compensation taxes,

assessments, excises, license fees, permit fees, and utility service charges of whatever nature, applicable to its operations at the Airport, including the Terminal Building Premises, and to take out and keep current all municipal, state or federal licenses required for the conduct of its business at and upon the Airport, including the Terminal Building Premises, and further covenants and agrees not to permit any of said taxes, assessments, excises, license fees, permit fees, or utility service charges to become delinquent. The Company agrees to furnish the City, upon request, duplicate receipts or other satisfactory evidence showing the prompt payment by the Company of all amounts required to be paid pursuant to this Section 10.1.

**10.2. Worker's Compensation Insurance.** The Company covenants and agrees at all times to maintain adequate Worker's Compensation Insurance (including occupational disease) in accordance with any present or future State law, with an authorized insurance company, or through the State Compensation Insurance Fund, or through an authorized self-insurance plan approved by the State, insuring the payment of compensation to all its employees. The Company agrees to furnish the City, upon request, duplicate receipts or other satisfactory evidence showing the prompt payment by the Company of all amounts required to be paid pursuant to this Section 10.2.

**10.3. Mechanic's and Materialmen's Liens.** The Company also covenants and agrees not to permit any mechanic's or materialman's or any other lien to be imposed upon the Terminal Building Premises or any other part of the Airport and improvements thereto or thereon, or any part or parcel thereof, by reason of any work or labor performed or materials furnished by any mechanic or materialman (other than for work done or materials furnished under a contract to which the City is a party) with respect to the Terminal Building Premises.

**10.4. Prompt Payment of Other Obligations.** The Company further covenants and agrees to pay promptly when due, all bills, debts and obligations incurred by it in connection with its business at the Airport, and not to permit the same to become delinquent and to suffer no lien, mortgage, judgment, or execution to be filed against the Terminal Building Premises or any part thereof which will in any way impair the rights of the City under this Agreement.

**10.5. Right of Contest.** The Company shall have the right on giving the City prior notice to contest any such mechanic's, materialman's or any other lien or encumbrance; and the Company shall not, pending the termination of such contest, be obligated to pay, remove, or otherwise discharge such lien or claim, provided, however, that the contest, in the judgment of the City, will not affect the possession, use or control of the Facilities. The Company agrees to indemnify and save harmless the City, its City Council, and its officers, employees, and other agents and representatives from any loss as a result of the Company's action as aforesaid.

**10.6. Nonpayment During Contest.** If the Company shall in good faith proceed to contest any general tax, special assessment, excise, license fee, permit fee, or other public charge, or the validity thereof by proper legal proceedings which shall operate to prevent the collection

thereof or to prevent the appointment of a receiver because of nonpayment of any such taxes, assessments, excises, fees, or other public charges, the Company shall not be required to pay, discharge, or remove any such tax, assessment, excise, fee, or other public charge so long as such proceeding is pending and undisposed of; provided, however, that the Company, not less than five days before any such tax, assessment, excise, fee, or other public charge shall become delinquent, shall give notice to the City of the Company's intention to contest its validity and provided further that the nonpayment, in the judgment of the City, will not affect the possession, use or control of the Terminal Building Premises. If such notice is so given by the Company to the City and such contest is conducted in good faith by the Company, the City shall not, pending the termination of such legal proceedings, pay, remove, or discharge such tax, assessment, excise, fee, or other public charge. The Company agrees to indemnify and save harmless the City, its City Council, and its officers, employees, and other agents and representatives from any loss as a result of the Company's action as aforesaid.

## **SECTION 11 EVENTS OF DEFAULT AND REMEDIES**

**11.1. Events of Default Defined.** The occurrence of any one or more of the events described in the following subsections A through D of this Section 11.1 shall constitute a "default" for all purposes of this Agreement; and each such default shall, after the giving of notice, if any, passage of time, if any, or occurrence of an event, if any, specified in the subsection describing such default, constitute an "event of default" for all purposes of this Agreement:

A. Failure by the Company to pay when due any Terminal Premises Rentals or Concession Fees required to be paid under Section 6 hereof; or failure to collect and remit the Customer Facility Charges as required under Section 6 hereof;

B. Any material breach by the Company of any of its representations or warranties made in this Agreement, any failure by the Company to make any payment required to be made by it hereunder or any failure by the Company to observe and perform any of its covenants, conditions or agreements made on its part to be observed or performed hereunder, other than a breach, failure to pay or failure to observe and perform referred to in subsection A of this Section 11.1, for a period of 30 days after written notice specifying such breach, failure to pay or failure to observe and perform and requesting that it be remedied, given to the Company by the City, unless (i) the City shall agree in writing to an extension of such time prior to its expiration or (ii) if the breach, failure to pay or failure to observe and perform be such that it can be corrected but cannot be corrected within the applicable period, corrective action is instituted by the Company within the applicable period and is being diligently pursued;

C. The dissolution or liquidation of the Company; or the filing by the Company of a voluntary petition in bankruptcy; or the entry of an order for relief under Title 11 of the United States Code, as the same may from time to time be hereafter amended, against the

Company; or the filing of a petition or answer proposing the entry of an order for relief against the Company under Title 11 of the United States Code, as the same may from time to time be hereafter amended, or proposing the reorganization, arrangement or debt readjustment of the Company under any present or future federal bankruptcy act or any similar federal or state law in any court and the failure of said petition or answer to be discharged or denied within 90 days after the filing thereof; or the appointment of a custodian (including without limitation a receiver, trustee or liquidator of the Company) of all or a substantial part of the property of the Company, and the failure of such a custodian to be discharged within 90 days after such appointment; or the taking by such a custodian of possession of the Company or a substantial part of its property, and the failure of such taking to be discharged within 90 days after such taking; or the Company's consent to or acquiescence in such appointment or taking; or assignment by the Company for the benefit of its creditors; or the entry by the Company into an agreement of composition with its creditors. The term "dissolution or liquidation of the Company," as used in this subsection, shall not be construed to include the cessation of the corporate existence of the Company resulting from a merger or consolidation of the Company into or with another corporation or a dissolution or liquidation of the Company following a transfer of all or substantially all of its assets, under the conditions permitting such actions contained in Section 7.2 hereof;

D. If the Company abandons, surrender, or vacates the premises or ceases to operate the concession; or

E. If the Company is in default under the Facilities Lease.

F. The foregoing provisions of Section 11.1 are subject to the following limitations: If by reason of Force Majeure the Company is unable in whole or in part to carry out its agreements on its part herein contained, other than the obligations on the part of the Company contained in Section 7.3 hereof or to make payments required hereunder, the Company shall not be deemed in default during the continuance of such inability. The Company agrees, however, to remedy with all reasonable dispatch the cause or causes preventing the Company from carrying out its agreements; provided that the settlement of strikes, lockouts and other disturbances shall be entirely within the discretion of the Company and the Company shall not be required to make settlement of strikes, lockouts and other disturbances by acceding to the demands of the opposing party or parties when such course is in the sole judgment of the Company unfavorable to the Company.

**11.2. Remedies on Default.** Whenever any event of default referred to in Section 11.1 hereof shall have happened and be continuing, the City shall have the right, at the City's election, then or at any time thereafter, to exercise any one or more of the following remedies:

A. The City may terminate this Agreement, effective at such time as may be specified by written notice to the Company, and demand (and, if such demand is refused, recover) possession of the Terminal Building Premises from the Company;

B. The Company shall remain liable to the City for damages in an amount equal to the Terminal Premises Rentals and Concession Fees payable pursuant to Sections 6.1 and 6.2 hereof, respectively, and other sums, including CFCs which have not been collected or turned over to the City, which would have been owing by the Company hereunder for the balance of the Term had this Agreement not been terminated, less the net proceeds, if any, from any reletting of the Terminal Building Premises by the City subsequent to such termination, after deducting all of the City's reasonable expenses in connection with such recovery of possession or reletting. The City is entitled to collect and receive such damages from the Company on the days on which the Terminal Premises Rentals and Concession Fees payable pursuant to Sections 6.1 and 6.2 hereof, respectively, and other amounts would have been payable if this Agreement had not been terminated. Alternatively, at the option of the City, the City shall be entitled to recover forthwith from the Company, as damages for loss of the bargain and not as a penalty, an aggregate sum which, at the time of such termination of this Agreement, represents the excess, if any, of (a) the aggregate of the Terminal Premises Rentals and Concession Fees payable pursuant to Sections 6.1 and 6.2 hereof, respectively, and all other sums payable by the Company hereunder that would have accrued for the balance of the Agreement Term, over (b) the rental value of the Terminal Building Premises for the balance of the term of the Agreement;

C. The City may reenter and take possession of the Terminal Building Premises or any part thereof, without demand or notice, and repossess the same and expel the Company and any party claiming by, under or through the Company, and remove the effects of both using such force for such purposes as may be necessary, without being liable for prosecution on account thereof or being deemed guilty of any manner of trespass, and without prejudice to any remedies for arrears of rent or right to bring any proceeding for breach of covenants or conditions. No such reentry or taking possession of the Terminal Building Premises by the City shall be construed as an election by the City to terminate this Agreement unless a written notice of such intention is given to the Company. No notice from the City hereunder or under a forcible entry and detainer statute or similar law shall constitute an election by the City to terminate this Agreement unless such notice specifically so states. The City reserves the right, following any reentry or reletting, to exercise its right to terminate this Agreement by giving the Company and the Paying Agent such written notice, in which event the Agreement will terminate as specified in said notice. After recovering possession of the Terminal Building Premises, the City may, from time to time, but shall not be obligated to, relet the Terminal Building Premises, or any part thereof, for such term or terms and on such conditions and upon such other terms as the City, in its sole discretion, may determine. The City may make such repairs, alterations or improvements as the City may consider appropriate to accomplish such reletting, and the Company shall reimburse the City upon demand for all costs and expenses, including attorneys' fees, which the City may incur in connection with such reletting. The City may collect and receive the rents for such reletting, but the City shall in no way be responsible or liable for any failure to relet the Terminal Building Premises, or any part thereof, or for any failure to collect any rent due upon such reletting. Notwithstanding the City's recovery of possession of the Terminal Building

Premises, the Company shall continue to pay on the dates herein specified, the rental payments payable under Section 6 hereof and other amounts which would be payable hereunder if such repossession had not occurred. Upon the expiration or earlier termination of this Agreement, the City shall refund to the Company any amount, without interest, by which the amounts paid by the Company, when added to the net amount, if any, recovered by the City through any reletting of the Terminal Building Premises, exceeds the amounts payable as Terminal Premises Rentals and Concession Fees by the Company under this Agreement. If, in connection with any reletting, the new lease term extends beyond the existing term, or the premises covered thereby include other premises not part of the Terminal Building Premises, a fair apportionment of the rent received from such reletting of the Terminal Building Premises and the expenses incurred in connection therewith will be made in determining the net amount recovered from such reletting; and

D. The City may take whatever action at law or in equity may appear necessary or desirable to collect the payments and other amounts then due and thereafter to become due hereunder or to enforce performance and observance of any obligation, agreement or covenant of the Company under this Agreement.

**11.3. Cross Default With Facilities and Ground Lease.** Notwithstanding anything to the contrary under this Agreement, a default by Company under this Agreement shall be an event of default under the Facilities and Ground Lease.

**11.4. No Remedy Exclusive.** No remedy herein conferred upon or reserved to the City is intended to be exclusive of any other available remedy or remedies, but each and every such remedy shall be cumulative and shall be in addition to every other remedy given under this Agreement or now or hereafter existing at law or in equity or by statute. No delay or omission to exercise any right or power accruing upon any default shall impair any such right or power or shall be construed to be a waiver thereof, but any such right and power may be exercised from time to time and as often as may be deemed expedient. In order to entitle the City to exercise any remedy reserved to it in this Section 11, it shall not be necessary to give any notice, other than such notice as may be herein expressly required.

**11.5. Agreement to Pay Fees and Expenses of Counsel.** In the event the Company should default under any of the provisions of this Agreement and the City should employ Counsel or incur other expenses for the collection of the amounts due hereunder or the enforcement or performance or observance of any obligation or agreement on the part of the Company herein contained, the Company agrees that it will on demand therefore pay the City or, if so directed by the City, to the Counsel for the City, the reasonable fees of such Counsel and such other expenses so incurred by or on behalf of the City.

**11.6. No Additional Waiver Implied by One Waiver.** In the event any agreement contained in this Agreement should be breached by either party and thereafter waived by the other party, such waiver shall be limited to the particular breach so waived and shall not be deemed to

waive any other breach hereunder. No waiver shall be effective unless it is in writing and signed by the party making the waiver.

## **SECTION 12 MISCELLANEOUS**

**12.1. No Personal Liability.** No manager, director, officer, employee or other agent of either party shall be personally liable under or in connection with this Agreement.

**12.2. Third Parties.** This Agreement does not, and shall not be deemed or construed to, confer upon or grant to any third party or parties (excepting any successor to the Company or any parties to whom the Company may assign this Agreement in accordance with Section 7.7 hereof, and excepting any successor to or assignee of the City) any right to claim damages or to bring any suit, action or other proceeding against either the City or the Company because of any breach hereof or because of any of the terms, covenants and conditions herein contained.

**12.3. No Limitation on Previous Agreements.** Subject to Section 12.13 hereof, it is expressly understood that the terms and provisions of this Agreement shall in no way affect or impair the terms, obligations or conditions of any existing or prior agreement between the Company and the City.

**12.4. Binding Effect.** This Agreement shall inure to the benefit of and shall be binding upon the City, the Company and their respective successors and assigns.

**12.5. Execution in Counterparts.** This Agreement may be executed in several counterparts, each of which shall be an original and all of which shall constitute but one and the same instrument.

**12.6. Amendments, Changes, and Modifications.** This Agreement may not be amended, changed, modified, altered or terminated by the City and the Company except as provided for herein. Thereafter, this Agreement may be amended at any time upon the mutual agreement of the City and the Company.

**12.7. Severability.** In the event any provision of this Agreement shall be held invalid or unenforceable by any court of competent jurisdiction, such holding shall not invalidate or render unenforceable any other provision hereof.

**12.8. Notices.** All notices, certificates or other communications hereunder shall be sufficiently given and shall be deemed given to the parties required hereunder to receive such notice, certificate or communication when mailed by registered mail, postage prepaid, addressed as follows:

**If to the City:** Denver International Airport  
8500 Peña Boulevard  
Denver, Colorado 80249-6340  
Attention: Manager of Aviation

and

Airport Property Office  
Denver International Airport  
8500 Pena Boulevard  
Denver, Colorado 80248-6340  
Attention: Assistant Deputy Manager

**If to the Company:** Kevin L. Hill, Vice President/General Manager  
Enterprise Leasing Company of Denver, LLC  
7201 S. Fulton St  
Centennial, CO 80112  
720-875-9910

With copy to:  
Enterprise Holdings, Inc.  
600 Corporate Park Drive  
St. Louis, MO 63105  
Attn: Airport Properties and Relations

The City and the Company may, by notice given hereunder, designate any further or different addresses to which subsequent notices, certificates or other communications shall be sent. No notice need be given to any party listed in this Section 12.8 if such party is no longer a party to the transactions contemplated by this Agreement.

**12.9. Further Assurances.** The Company and the City both agree that they shall, from time to time, execute and deliver such further instruments and take such further actions as may be reasonably required to carry out the purposes of this Agreement.

**12.10. Applicable Law.** This Agreement shall be governed exclusively by and construed in accordance with the laws of the State of Colorado.

**12.11. City's Obligations Limited.**

A. Notwithstanding anything herein to the contrary, it is expressly understood and agreed by the parties hereto that (a) the City may rely conclusively on the truth and accuracy of any certificate, opinion, notice, or other instrument furnished to the City by the Company as to the



existence of any fact or state of affairs required hereunder to be noticed by the City; (b) the City shall not be under any obligation hereunder to perform any record keeping, it being understood that such services shall be performed by the Company; and (c) none of the provisions of this Agreement shall require the City to expend or risk its own funds or to otherwise incur financial liability in the performance of any of its duties or in the exercise of any of its rights or powers hereunder, unless it shall first have been adequately indemnified to its satisfaction against the cost, expenses and liability which may be incurred thereby.

B. Notwithstanding anything herein to the contrary, any obligation which the City may incur under this Agreement or under any instrument executed in connection herewith which shall entail the expenditure of money shall not be a general obligation of the City.

**12.12. Compliance with Laws, Ordinances and Rules and Regulations.** The Company agrees that at all times in the operation and use of the Airport it shall comply with all federal, state and local laws, regulations and ordinances, including but not limited to all applicable rules and regulations of the Federal Aviation Administration, the Transportation Security Administration, and all rules and regulation of the City with respect to the Airport.

**12.13. City Execution Of Agreement.** This Agreement is expressly subject to, and shall not become effective or binding on the City, until it is fully executed by all signatories of the City and County of Denver. This Agreement may be signed electronically by either party in the manner specified by the City.

**END OF AGREEMENT  
SIGNATURE PAGES AND EXHIBITS FOLLOW**

**APPENDIX NO. 1**  
**STANDARD FEDERAL ASSURANCES AND NONDISCRIMINATION**

NOTE: As used below the term "contractor" shall mean and include the Company, and the term "sponsor" shall mean the "City".

During the term of this contract, the contractor, for itself, its assignees and successors in interest (hereinafter referred to as the "contractor") agrees as follows:

1. Compliance with Regulations. The contractor shall comply with the Regulations relative to nondiscrimination in federally assisted programs of the Department of Transportation (hereinafter "DOT") Title 49, Code of Federal Regulations, Part 21, as they may be amended from time to time (hereinafter referred to as the Regulations), which are herein incorporated by reference and made a part of this contract.
2. Nondiscrimination. The contractor, with regard to the work performed by it during the contract, shall not discriminate on the grounds of race, creed, color, sex, national origin in the selection and retention of subcontractors, including procurements of materials and leases of equipment. The contractor shall not participate either directly or indirectly in the discrimination prohibited by section 21.5 of the Regulations, including employment practices when the contract covers a program set forth in Appendix B of the Regulations.
3. Solicitations for Subcontractors, Including Procurements of Materials and Equipment. In all solicitations either by competitive bidding or negotiation made by the contractor for work to be performed under a subcontract, including procurements of materials or leases of equipment, each potential subcontractor or supplier shall be notified by the contractor of the contractor's obligations under this contract and the Regulations relative to nondiscrimination on the grounds of race, color, or national origin.
4. Information and Reports. The contractor shall provide all information and reports required by the Regulations or directives issued pursuant thereto and shall permit access to its books, records, accounts other sources of information, and its facilities as may be determined by the sponsor or the Federal Aviation Administration (FAA) to be pertinent to ascertain compliance with such Regulations, orders, and instructions. Where any information required of a contractor is in the exclusive possession of another who fails or refuses to furnish this information, the contractor shall so certify to the sponsor of the FAA, as appropriate, and shall set forth what efforts it has made to obtain the information.
5. Sanctions for Noncompliance. In the event of the contractor's noncompliance with the nondiscrimination provisions of this contract, the sponsor shall impose such contract sanctions as it or the FAA may determine to be appropriate, including, but not limited to:
  - a. Withholding of payments to the contractor under the contract until the contractor complies, and/or
  - b. Cancellation, termination, or suspension of the contract, in whole or in part.
6. Incorporation of Provisions. The contractor shall include the provisions of paragraphs 1 through 5 in every subcontract, including procurements of materials and leases of equipment, unless exempt by the Regulations or directives issued pursuant thereto. The contractor shall take such action with respect to any subcontract or procurement as the sponsor or the FAA may direct as a means of enforcing such provisions including sanctions for noncompliance. Provided, however, that in the event a contractor becomes involved in, or is threatened with, litigation with a subcontractor or supplier as a result of such direction, the contractor may request the sponsor to enter into such litigation to protect the interests of the sponsor and, in addition, the contractor may request the United States to enter into such litigation to protect the interests of the United States.
7. The Company for itself, its representatives, successors in interest, and assigns, as a part of the consideration hereof, does hereby covenant and agree as a covenant running with the land that in the event facilities are constructed, maintained, or otherwise operated on the said property described in this agreement for a purpose for which a DOT program or activity is extended or for another purpose involving the provision of similar services or benefits, the Airline shall maintain and operate such facilities and services in compliance with all other requirements imposed pursuant to 49 CFR Part 21, Nondiscrimination in Federally Assisted Programs of the Department of Transportation, and as said Regulations may be amended.
8. The Company for itself, representatives, successors in interest, and assigns, as a part of the consideration

hereof, does hereby covenant and agree as a covenant running with the land: (1) that no person on the grounds of race, color, sex, creed or national origin shall be excluded from participation in, denied the benefits of, or be otherwise subjected to discrimination in the use of said facilities, (2) that in the construction of any improvements on, over, or under such land and the furnishing of services thereon, no person on the grounds of race, color, sex, creed or national origin shall be excluded from participation in, denied the benefits of, or otherwise be subjected to discrimination, (3) that the Company shall use the premises in compliance with all other requirements imposed by or pursuant to 49 CFR Part 21, Nondiscrimination in Federally Assisted Programs of the Department of Transportation, and as said Regulations may be amended.

9. **NONDISCRIMINATION IN AIRPORT EMPLOYMENT OPPORTUNITIES**

The Company assures that it will comply with pertinent statutes, Executive Orders and such rules as are promulgated to assure that no person shall, on the grounds of race, creed, color, national origin, sex, age, or handicap be excluded from participating in any activity conducted with or benefiting from Federal assistance.

It is unlawful for airport operators and their lessees, tenants, concessionaires and contractors to discriminate against any person because of race, color, national origin, sex, creed, or handicap in public services and employment opportunities.

**Contract Control Number:**

IN WITNESS WHEREOF, the parties have set their hands and affixed their seals at Denver, Colorado as of

SEAL

**CITY AND COUNTY OF DENVER**

ATTEST:

By \_\_\_\_\_

\_\_\_\_\_

APPROVED AS TO FORM:

REGISTERED AND COUNTERSIGNED:

By \_\_\_\_\_

By \_\_\_\_\_

By \_\_\_\_\_



Contract Control Number: PLANE-201314190-00

Contractor Name: Enterprise Leasing Company of Denver, LLC

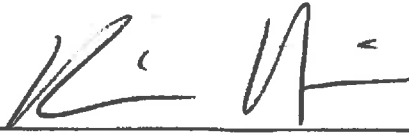
By: 

Name: KEVIN ITEN  
(please print)

Title: VICE PRESIDENT + GENERAL MANAGER  
(please print)

ATTEST: [if required]

By: 

Name: Christine Olson  
(please print)

Title: Administrative Assistant  
(please print)

KH



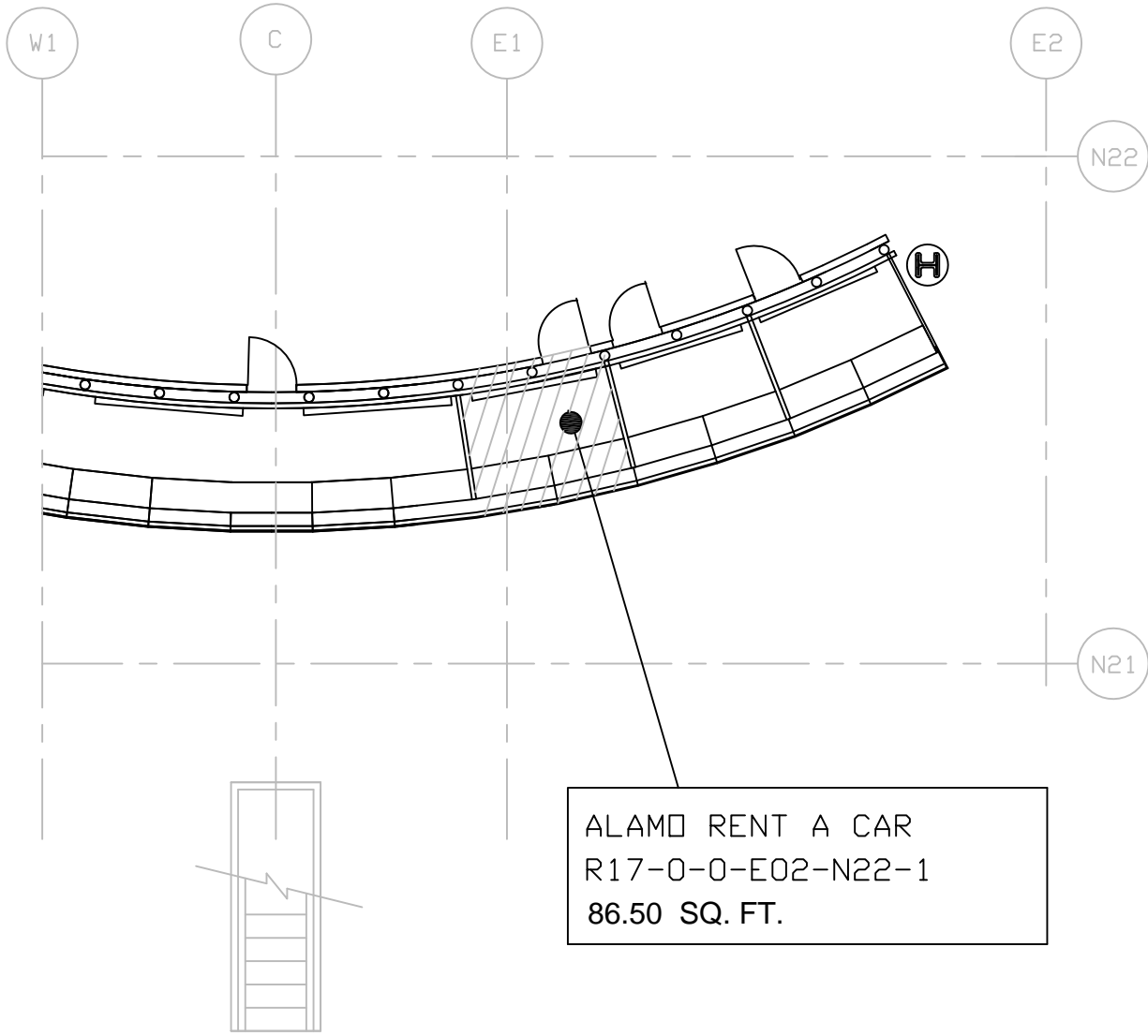

ALAMO RENT A CAR  
 R17-0-0-E02-N22-1  
 86.50 SQ. FT.

KEY PLAN  
 TERMINAL AREA

LEVEL 5 - TERMINAL

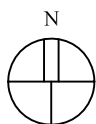
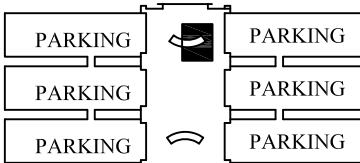

DRAWN  
 11-11-2013

DENVER INTERNATIONAL AIRPORT  
 EXHIBIT A - COUNTER POSITION  
 ALAMO RENT A CAR

ENTERPRISE/NATIONAL  
 R16-0-0-W01-N12-1  
 129.50 SQ. FT.

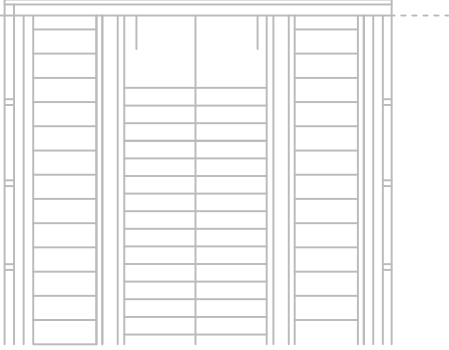
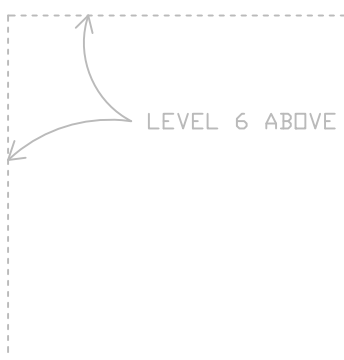
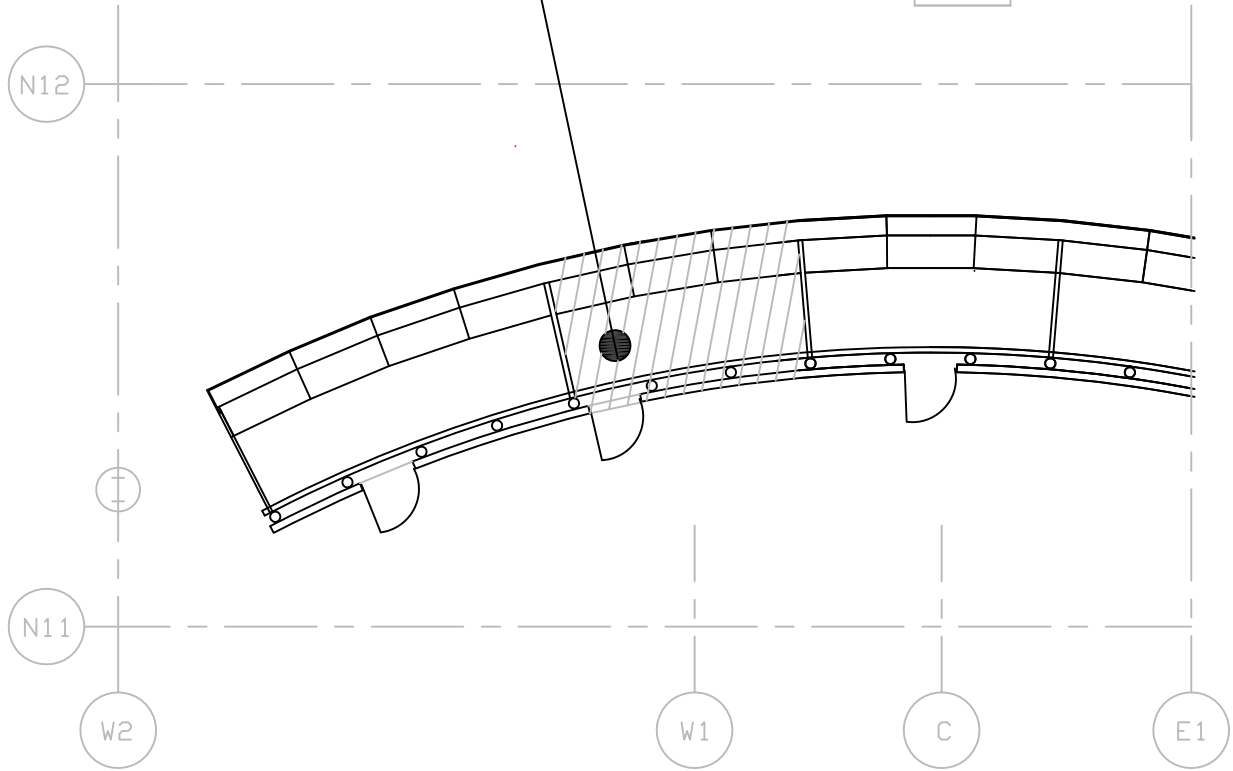
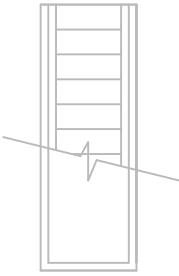

KEY PLAN  
 TERMINAL AREA

LEVEL 5 - TERMINAL

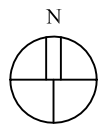
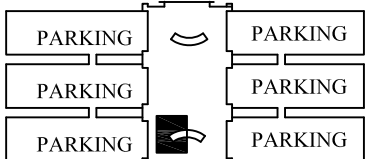

DRAWN  
 11-11-2013

DENVER INTERNATIONAL AIRPORT  
 EXHIBIT A - COUNTER POSITION  
 ENTERPRISE/NATIONAL RENT A CAR

**EXHIBIT C - ACDBE COMMITMENT FORM**

**DENVER INTERNATIONAL AIRPORT  
CITY AND COUNTY OF DENVER  
DIVISION OF SMALL BUSINESS OPPORTUNITY**

---

Concession Agreement for: Car Rental Operations

**SECTION A – COMPANY INFORMATION**

Name of Firm: \_\_\_\_\_

Address: \_\_\_\_\_

City: \_\_\_\_\_ State: \_\_\_\_\_ Zip: \_\_\_\_\_

Contact Person: \_\_\_\_\_ Telephone: \_\_\_\_\_

Email: \_\_\_\_\_

Is your firm ACDBE Certified: Yes \_\_\_\_\_ No \_\_\_\_\_ *If Certified, Attach Certification Letter*

**SECTION B – ACDBE COMMITMENT**

The ACDBE goal on this concession is **2 %**.

*NOTE: The DSBO will only credit ACDBE participation that is certified as such by the City and County of Denver, Division of Small Business Opportunity (DSBO) or the Colorado Department of Transportation.*

1. The undersigned proposer/concessionaire has satisfied the ACDBE concession requirements in the following manner (please check the appropriate space).

\_\_\_ The proposer is committed to a minimum of \_\_\_\_\_% ACDBE utilization on this concession contract which meets or exceeds the ACDBE goal on this concession opportunity. The amount and type of participation proposed will become a firm commitment in the Lease Agreement.

\_\_\_ The proposer, unable to meet the ACDBE goal, is committed to a minimum of \_\_\_\_\_% ACDBE utilization on this concession contract and submits its documentation demonstrating good faith efforts.

\_\_\_ The proposer is unable to meet the ACDBE goal and submits documentation demonstrating good faith efforts.

2. Identify ACDBE sub-concessionaire, ACDBE joint venture partner, ACDBE equity partnership or other legal ACDBE business arrangement that meets ACDBE goal and eligibility standards in 49 CFR Part 23.



**NOTE: An ACDBE Letter of Intent must be submitted for all ACDBE suppliers listed below. Attach copy of the ACDBE Certification Letter for all ACDBEs, regardless of participation type.**

Name & Address of ACDBE Firm	Role of ACDBE	% Level of Participation

(Use Additional Sheets if Necessary)

**ACDBE UTILIZATION – VENDOR/SUPPLIERS OPPORTUNITIES**

**NOTE: Complete only if suppliers will be used to meet any portion of the ACDBE goal**

List all actual *and* anticipated major vendors/suppliers; include **both** ACDBE and non-ACDBE, to be utilized on the concession (use additional sheets if necessary). Examples: Janitorial services, accounting services, HR services, etc.

**NOTE: The DSBO will only credit ACDBE participation that is certified as such by the City and County of Denver, Division of Small Business Opportunity (DSBO) or the Colorado Department of Transportation.**

Name and Address of Company	Business Area	Work to be Performed or Goods/Services to be provided	Estimated Amount (\$)	ACDBE		LOI & Cert Letter Attached
				Y	N	

(Use Additional Sheets if Necessary)

**ACDBE Letter of Intent Form**

**Concessionaire/Proposer:** \_\_\_\_\_

Address: \_\_\_\_\_

City: \_\_\_\_\_ State: \_\_\_\_\_ Zip \_\_\_\_\_

Telephone: \_\_\_\_\_ E-mail address \_\_\_\_\_

**ACDBE Supplier/Vendor:** \_\_\_\_\_

Address: \_\_\_\_\_

City: \_\_\_\_\_ State: \_\_\_\_\_ Zip \_\_\_\_\_

Telephone: \_\_\_\_\_ E-mail address \_\_\_\_\_

Description of the goods, services and/or work to be provided/performed by the ACDBE firm:

The Concessionaire is committed to utilizing the above named ACDBE firm for the goods, services and/or work described above. The estimated dollar value of these goods, services and/or work per year is \$\_\_\_\_\_.

**AFFIRMATION:**

The above-named ACDBE firm affirms that it will perform the portion of the contract for the estimated dollar value as stated above.

By: \_\_\_\_\_  
Concessionaire Signature Title Date

By: \_\_\_\_\_  
ACDBE Signature Title Date

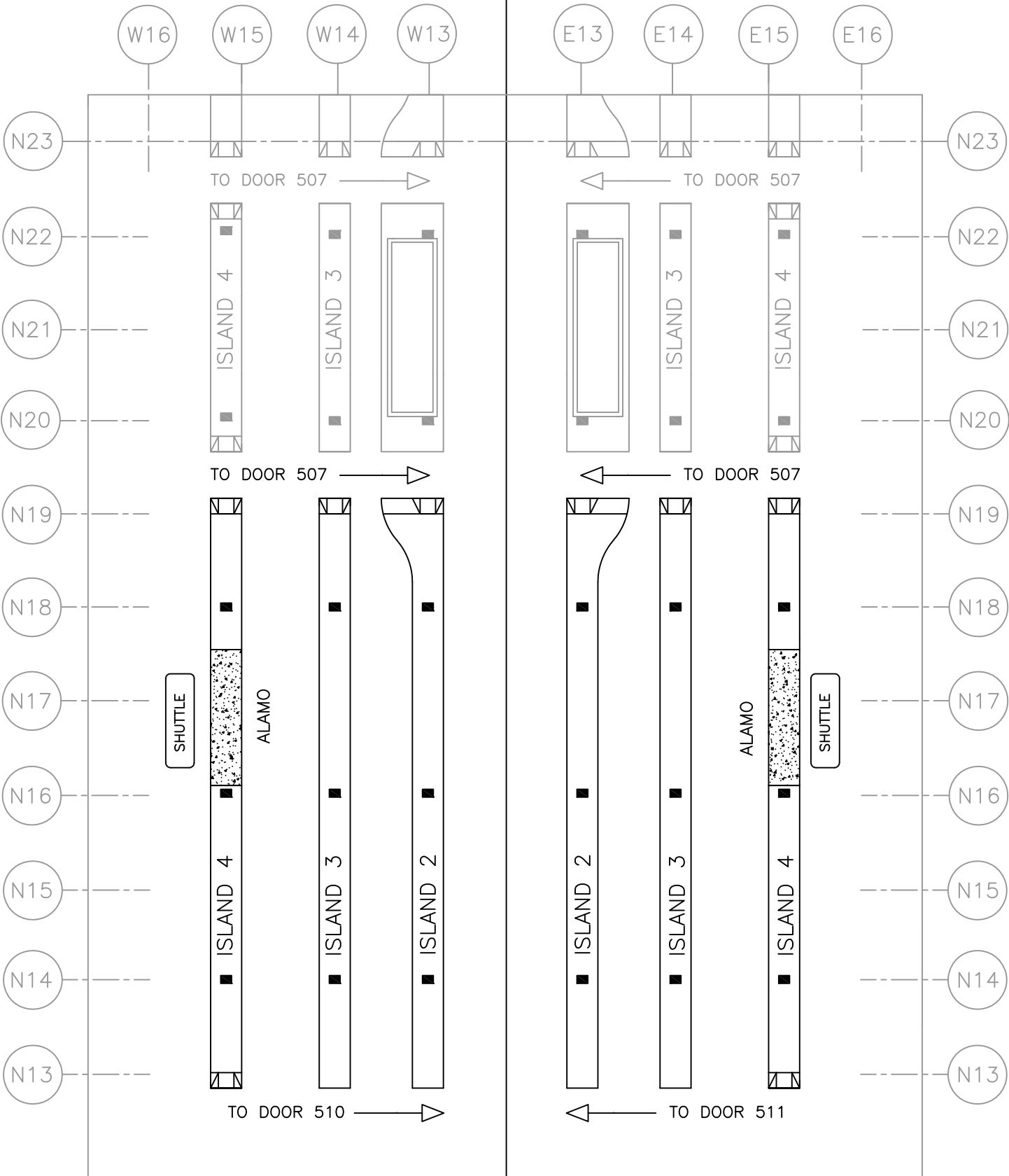

TERMINAL LEVEL 5 - WEST SIDE

TERMINAL LEVEL 5 - EAST SIDE

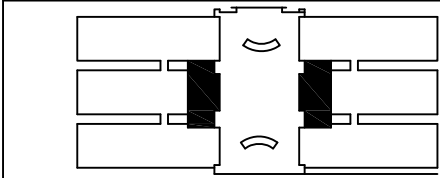

KEY PLAN  
TERMINAL AREA

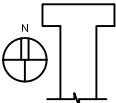

DRAWN

11-11-2013

DENVER INTERNATIONAL AIRPORT

EXHIBIT H - BUS PICKUP LOCATION  
ALAMO RENT A CAR

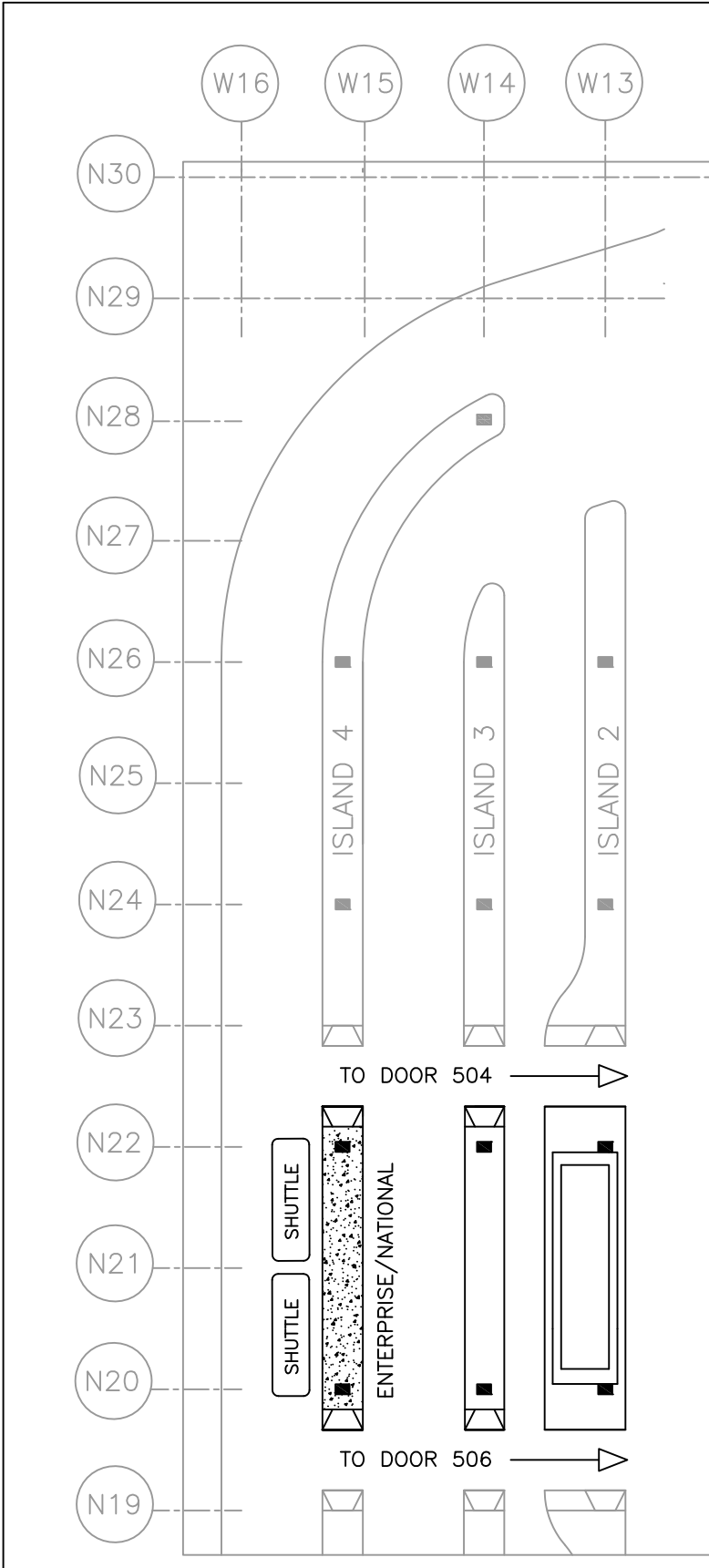

TERMINAL LEVEL 5 - WEST SIDE

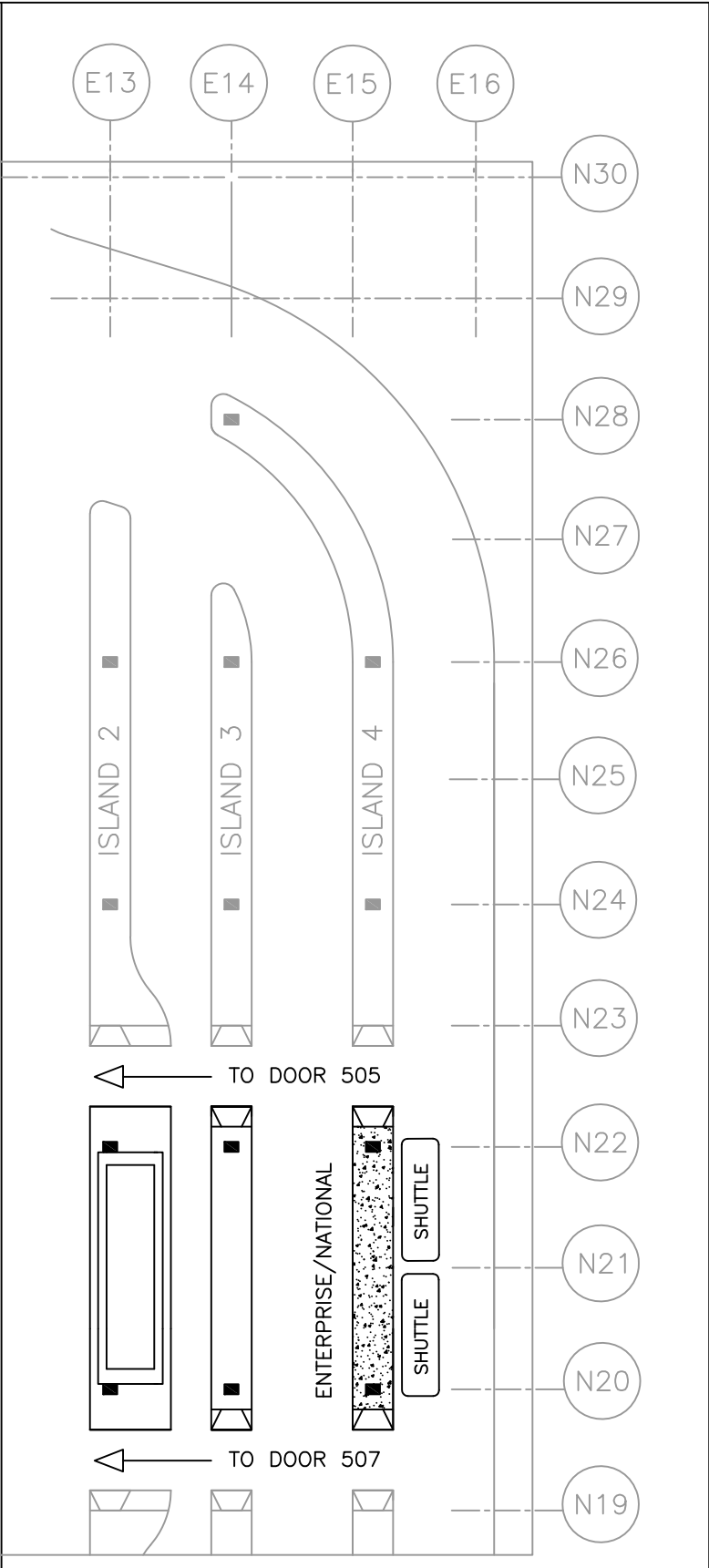

TERMINAL LEVEL 5 - EAST SIDE

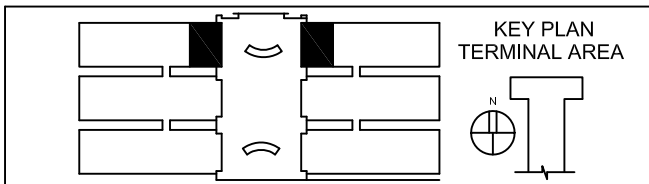

REVISED	DENVER INTERNATIONAL AIRPORT
	EXHIBIT H - BUS PICKUP LOCATION ENTERPRISE/NATIONAL RENT A CAR
	Page 2 of 2
	DATE: 11/11/13

## EXHIBIT X

### PROVISIONS FOR DESIGN AND CONSTRUCTION OF IMPROVEMENTS

#### GENERAL PROVISIONS

SECTION 1: GENERAL. Except as the context otherwise requires and unless otherwise expressly provided herein, the capitalized terms in this Exhibit X to the Agreement shall have the same meaning as any similarly capitalized terms defined in the Agreement or any exhibit thereto. Reference to Denver International Airport (DIA), Department of Aviation or Manager of Aviation shall mean that entity specifically, or that division or individual authorized to represent that entity. Reference to Tenant shall include "Concessionaire" as the context requires.

SECTION 2: IMPROVEMENTS. "Improvements," which may also be known as "Concession Improvements" or "Tenant Improvements," shall mean any new construction, equipment, finishes, fixtures, systems, furnishings and furniture installed by Tenant, as well as modifications or alterations to existing construction, equipment, finishes, fixtures, systems, furnishings and furniture which conform to drawings and specifications approved in writing by the Manager of Aviation. Such drawings and specifications must provide for the necessary and proper operation of the business contemplated under this Agreement.

SECTION 3: COMPLIANCE WITH LAWS AND REGULATIONS. Tenant agrees to comply with and require its contractors to comply with all applicable federal, state and local laws and all general rules and regulations applicable to construction at DIA, including but not limited to payment of prevailing wages and sales and use taxes, compliance with the Americans with Disabilities Act, 42 USC 12,000 et seq. and its regulations.

In addition to the above, the Tenant and its contractors shall comply with all DIA specific rules and regulations regarding site access, use of site, safety, security, design and construction and shall obtain and pay for all related permits. Failure to comply will be grounds for denial of access and/or suspension of construction activities. Regulations in force specific to DIA include but are not limited to the following:

The Denver Municipal Airport System Rules and Regulations

DIA Design Standards

DIA Tenant Development Guidelines

SECTION 4: PAYMENT OF PREVAILING WAGE RATES. Tenant shall require its contractor and all of its subcontractors to pay every worker, laborer or mechanic employed by them in the performance of the construction of the Improvements prevailing wages, including fringe benefits or their cash equivalent, for the same class and kind of work in the City and County of Denver, as determined by the Career Service Board under the provisions of Section 20-76 of the Denver Revised Municipal Code. The wages shall be those prevailing at the time of the contractor's final bid, and the Tenant shall require the contractor to submit with its bid the wage schedule applicable. The contractor shall post in a prominent and easily accessible place at the site of the Improvements the scale of wages to be paid by the contractor and all subcontractors at any tier working under the contractor. The contractor shall furnish to the Mayor's Office of Contract Compliance and to the Auditor, or his authorized representative, each week during which work

is in progress, a true and correct copy of the payroll records of all workers employed to perform the work. All payroll records shall include information showing the number of hours worked by each worker, the hourly pay of such worker, any deductions made from pay, and the net amount of pay received by such worker for the period covered by the payroll. The payroll record shall be accompanied by a sworn statement of the contractor that the copy is a true and correct copy of the payroll records of all workers performing the work, either for the contractors or subcontractors, that payments were made to the workers as set forth in the payroll records, that no deductions were made other than those set forth in such records, and that all workers were paid the prevailing wages as of the contractor's final bid for the work. Compliance with above requirements shall be deemed a work "specification" as such word is used in Section 5-18(d), Denver Revised Municipal Code. Violation of the prevailing wage requirement and its documentation, hereinabove set forth, shall result in an order from the Manager of Aviation for the work to cease until there is satisfactory evidence that the violation has been remedied and will not reoccur. The issuance of a stop-work order shall not relieve contractor's surety of any liability on contractor's bond or bonds, but such a stop-work order shall be deemed a default by the contractor insofar as said surety's obligation is concerned.

**SECTION 5: SBE AND MBE/WBE PARTICIPATION.** This Agreement is subject to the requirements of Articles III and VII of the Denver Revised Municipal Code.

Tenant agrees that it shall provide for participation of Small Business Enterprises (SBEs) in the design and construction of Improvements, in compliance with Article VII, Division 1 of Chapter 28, Denver Revised Municipal Code (D.R.M.C.), or any successor ordinance effective at the time of any design and construction which Tenant may carry out during the life of this Agreement. The goal for percentage of design and construction work to be performed by SBE firms is set forth on the Construction Summary Page, and Tenant shall make a good faith effort to meet such goals as have been set in accordance with the ordinance. Further, the City and County of Denver encourages Tenants to utilize SBEs and to divide the design and construction work into economically feasible units or segments to allow the most opportunity for subcontracting.

Tenant agrees that it shall provide for participation of Minority Business Enterprises ("MBE") and Women Business Enterprises ("WBE") in the design and construction of Improvements, in compliance with the requirements of Article III, Divisions 1 and 3 of Chapter 28, of the Denver Revised Municipal Code ("MBE/WBE Ordinance"), or applicable successor ordinance, during the life of this Agreement. Tenant agrees to comply with rules and regulations issued by the Director of the Division of Small Business Opportunity ("DSBO"), a division of the Mayor's Office of Economic Development. The goal for percentage of design and construction work to be performed by MBE/WBE firms is set forth on the Construction Summary Page, and Tenant shall meet, or make a good faith effort to meet, such goals as have been set in accordance with the ordinance. Further, the City and County of Denver encourages Tenants to utilize MBE/WBE firms and to divide the design and construction work into economically feasible units or segments to allow the most opportunity for subcontracting.

**SECTION 6: INSURANCE REQUIREMENTS.** Refer to Appendix B of Manual 1 of the DIA Tenant Development Guidelines for insurance requirements for Tenant, Tenant's Design Consultants and Tenant's Contractors for required insurance coverage for design and construction of Improvements and completed Improvements, including requirements for submittal of certificates and renewals of insurance.

SECTION 7: EVIDENCE OF INSURANCE. Certified copies of required insurance policies, or certificates, in the standard form required, evidencing the existence thereof, or binders, shall be delivered to the DIA Division of Planning and Development at least 15 days prior to the commencement of any design work to be performed by Tenant's consultants and any construction work for Improvements. If a binder is delivered, it shall be replaced within 30 days by a certified copy of the policy or the required certificate. Policies shall be in a form and of a company acceptable to and approved by the City, and certificates shall be on standard City and County of Denver Certificate of Insurance forms.

Each such policy or certificate shall contain a valid provision or endorsement that the policy may not be canceled, terminated, changed or modified without 45 days prior written notice (10 days for nonpayment of premium) given by certified mail, return receipt requested, to the Manager of Aviation, 8500 Peña Boulevard, Denver, Colorado 80249-6340.

Each such policy or certificate shall further provide that any coverage afforded the City and County of Denver as an additional insured under the policy shall apply as primary insurance and any other insurance issued to the City and County of Denver shall apply as excess and noncontributing insurance.

Any renewal certificate shall be delivered to the Manager of Aviation at least 10 days prior to the expiration of each expiring policy. If at any time any of the insurance policies shall be or become unsatisfactory to the Manager of Aviation as to form or substance, or if any of the carriers issuing such policies shall be or become unsatisfactory to the Manager of Aviation, Tenant shall promptly obtain a new and satisfactory replacement policy.

SECTION 8: LIMITATION ON LIABILITY. Tenant agrees that no liability shall attach to the City for any damages or losses incurred or claimed by Tenant or any other person or party on account of the construction or installation of the Improvements or other Improvements to the Tenant's site made by the Tenant. Tenant agrees that no liability shall attach to the City for any interference or delay caused by construction in adjacent areas, travelers, other businesses or airport operations, including without limitation damages or losses in the nature of delay damages, lost labor productivity, and impact damages. Tenant agrees to indemnify, defend and hold harmless the City from any loss, cost, damage or expense incurred, claimed, asserted or arising in connection with Tenant's or its contractors' or agents', construction or installation of the Improvements or other Improvements to the site made by the Tenant.

## **DESIGN PROVISIONS**

SECTION 9: DESIGN PROCEDURES. Refer to Manual 1 of the DIA Tenant Development Guidelines for procedures and requirements regarding design, including but not limited to design process and schedule, submittal requirements, review and approval process, design modifications and project coordination.

Approval of the Manager of Aviation extends to and includes consideration of architectural, structural, mechanical, electrical, specialty systems, site, signage, landscaping and aesthetic matters, and DIA reserves the right to reject any design submitted and to require Tenant to resubmit designs and layout proposals until they meet with the approval of the Manager of Aviation. No substantial changes or alterations shall be made in said drawings or specifications after approval by the Manager of Aviation, and no alterations or improvements shall be made to or upon the Tenant's site without prior approval.

Tenant CADD Submittal Requirements: All issue for construction and project record drawings shall be provided by the Tenant to DIA in AutoCAD Rel. 2007 .dwg file format in accordance with DIA CADD standards set forth in Design Standards Manual 1. All design drawings submitted by the Tenant to the DIA shall be provided in the latest release of AutoCAD format in accordance with the DIA's Design Standards Manual.

Concession CADD Submittal Requirements: AutoCAD 2007 .dwg format CADD files that match the Tenant's hardcopy drawings must be submitted via: CD-ROM or DVD-ROM in MS-Windows format. All drawings must represent precision input and follow industry standard CADD practices. The drawings must reflect true design dimensioning and must NOT be graphic representations of the design. All site, civil and utility drawings MUST be produced using units in feet and the DIA Grid Coordinate System. The DIA project manager must approve submittal and may require adherence to the requirements set forth in DIA design standards.

In addition to the above, Tenant is responsible for coordination with the Denver Building Inspection Division, Zoning, Fire Department, Wastewater Management, Consumer Protection, Health and Hospitals, etc. as may be required to comply with submittal, review and approval requirements in order to obtain all required permits. Prior to the issuance of a Notice to Proceed with Improvements from the Manager of Aviation, the Tenant shall obtain and pay for all approvals, licenses and permits required for the Improvements. Whenever a conflict arises between state or local law, ordinances or regulations and federal law or regulations, the most stringent law or regulations applicable to this Agreement shall control.

SECTION 10: DESIGN STANDARDS. First-class standards of design and construction are required, and all Improvements shall conform to applicable statutes, ordinances, building codes, and regulations as well as the DIA Design Standards and DIA Tenant Development Guidelines, as they may be amended from time to time, and any other applicable design, construction, and maintenance standards.

Approval of the Manager of Aviation shall extend to and include consideration of architectural and aesthetic matters and the City reserves the right to reject any designs submitted and to require the Tenant to resubmit designs and layout proposals until they meet with the City's approval. If any portion of the plans and specifications is disapproved by the City, the Tenant shall promptly submit necessary modifications and revisions thereof. The approval given by the Manager of Aviation shall not constitute a representation or warranty as to such conformity; therefore, responsibility remains with the Tenant at all times.

### **CONSTRUCTION PROVISIONS**

SECTION 11: CONSTRUCTION PROCEDURES. Refer to Manual 1 of the DIA Tenant Development Guidelines for procedures and requirements regarding construction, including but not limited to construction schedule, submittal requirements, review and approval process, construction inspections, construction modifications and project coordination.

Compliance with standards: All construction work shall comply with the requirements of and standards established by the City and all other appropriate governmental agencies and entities. The City shall at all times have the right to monitor and inspect any construction to assure that the Improvements are constructed and installed in full compliance with the plans and specifications.



Standard of Performance: All work done by the Tenant or its contractors shall be done in a first-class workmanlike manner using only good grades of materials and shall comply with all insurance requirements and all applicable laws and ordinances and rules and regulations of governmental departments or agencies. Whenever a conflict arises between State or local law, ordinances or regulations and Federal law or regulations, Federal law or regulations applicable to this agreement shall control.

City Inspection: All construction work, materials, and installations involved in or incidental to the construction of the improvements undertaken by the Tenant throughout the term hereof shall be subject at all times to inspection and approval by the City. DIA shall at all times have the right of access to the construction site and to monitor and inspect the construction of all Improvements to insure that all Improvements are constructed and installed in compliance with approved drawings and specifications.

DIA shall have the right to halt construction of the Improvements or deny access to the site at any time if construction is at material variance from the approved drawings and specifications until such variance is corrected, or if such construction poses an immediate safety hazard at the Airport, until such safety hazard is eliminated. The City shall cooperate and use its best efforts to alleviate and resolve any such variance or impediment to the safe operation of the Airport so as to permit continued construction as expeditiously as possible.

In order to assist DIA in monitoring and inspecting construction, the Tenant shall submit, or cause to be submitted for information and record, copies of all field test reports, certificates of insurance, waivers of liens, material certificates, shop drawings and submittals for review for compliance with DIA design and construction standards, contractor application for payment requests, construction progress reports, notification of substantial completion of Improvements and final acceptance, two copies of maintenance and operation manuals in connection with building systems and all updates thereof, as-built documents, and any other documents related to the construction of the Improvements which may be reasonably requested by DIA.

No change order or other contract modification which materially changes the scope of the Improvements shall be executed without prior approval of the Manager of Aviation, whose approval shall not be unreasonably withheld. The City will approve, conditionally approve, or disapprove submissions of change orders which materially change the scope of the work within a reasonable period of time following receipt thereof. Any conditional approval or disapproval shall be accompanied by an explanation as to the reason for the condition.

The Building Inspection Division of the City and County of Denver shall also receive copies of all change orders. Any conditional approval or disapproval shall be accompanied by an explanation of the reasons.

Tenant is responsible for all temporary utilities required during construction. Tenant, at its sole cost and expense, shall obtain and make utility connections, hook-ups or taps as necessary or as stipulated in this Agreement, securing all necessary applications or permits and paying all associated fees. Tenant, at its sole cost and expense, shall provide meters, calibrated by the utility company, and maintain equipment as required to provide accurate measurement of usage and consumption. DIA makes no warranty as to the location of structures, wiring, fixtures or systems, and Tenant accepts them on an "as is" basis without further recourse against DIA as to their location, number or suitability for the particular purposes of the Tenant.

Tenant is responsible for maintaining a clean, orderly and safe construction site, free of accumulated construction debris and waste materials and shall be responsible for legal removal of same. Construction shall be accomplished without interfering with travelers, airport operations or other businesses, providing barricades and/or construction enclosures as required.

**SECTION 12: CONSTRUCTION BONDS AND PERMITS.** Prior to Notice to Proceed with construction Improvements, Tenant and its contractor shall deliver to the Manager of Aviation performance and payment bonds and copies of all required permits, licenses and all other documents as required by Manual 1 of the DIA Tenant Development Guidelines.

**SECTION 13: MODIFICATIONS AND ALTERATIONS.** Modifications and alterations to existing tenant improvements are subject to the same requirements and provisions as new tenant improvements as itemized in this Exhibit X and the Lease Agreement.

**Advance Notice of Modification:** The Tenant shall give or cause to be given to the City advance notice before performing any material modification to the improvements.

**Expense of Alterations.** Any work necessary to make any alterations, improvements, or additions to the facility throughout the term of this Agreement shall be done at the Tenant's cost and expense, in accordance with and subject to all of the required approvals, submittals, and procedures, and all other requirements of whatsoever nature, as set forth herein.

**SECTION 14: AS-BUILT DOCUMENTS.** Not later than 60 days after completion of all work for the Improvements, Tenant shall provide DIA two complete sets of as-built documents prepared in accordance with DIA requirements. If Tenant fails to provide as-built documents after written notice from DIA, DIA may elect to have the documents completed and charge the Tenant for the costs associated therewith. Tenant agrees that, upon the request of DIA, Tenant will inspect the Improvements jointly with DIA to verify as-built documents.