

Master Purchase Order

DO NOT INVOICE TO THIS ADDRESS		Master Purchase Order No.	0823A0115		
City & County of Denver		Date:	08/11/2015	Revision No.	
Purchasing Division		Payment Terms	Net 30	Ordinance (as applicable):	
201 West Colfax Avenue, Dept. 304		Freight Terms	DESTINATION		
Denver, CO 80202		Ship Via	Best		
United States		Buyer:	Curtis Subia, CPPB		
Phone: 720-913-8100		Phone:	303-342-2113		
Fax: 720-913-8101		Email:	curtis.subia@denvergov.org		

PS Vendor ID: 0000075227 Phone: 801-627-6600 Fax: 801-629-3473 Email: garrett.macfarlane@jbtcc.com

John Bean Technologies Corporation
 dba JBT AeroTech, Jetway Systems
 1805 West 2550 South
 Ogden, UT 84401
 Attn: J. Garrett Macfarlane
 Colorado Secretary of State ID: 20081426823

Ship To: Denver International Airport
 8500 Pena Boulevard
 Denver, CO 80249

Bill To: As Specified By Agency

1. Goods/Services:

John Bean Technologies Corporation, dba JBT AeroTech, Jetway Systems, a Utah Corporation, (“Vendor”) shall provide the goods, and any services related thereto, identified and described on attached **Exhibit A**, to the City and County of Denver, a Colorado municipal corporation (the “City”), all in accordance with the terms and conditions of this Master Purchase Order.

2. Ordering:

The City shall purchase one or more of the goods/services by issuing a written purchase order(s) or similar appropriate written document (“Order”), each of which will be deemed incorporated into this Agreement for purposes of such Order only.

3. Pricing:

The pricing/rates for the goods/services is contained on **Exhibit A** and shall be held firm for the term of this Master Purchase Order.

4. Term:

The term of this Master Purchase Order shall run from date of City Signature to and including December 31, 2016.

5. Extension or Renewal:

It is also a specific provision of this Master Purchase Order that the City and the vendor may mutually agree to renew and continue the contract or agreement consummated under this Master Purchase Order for additional periods of one year at the same prices, terms and conditions. However, no more than six (6) yearly extensions shall be made to the original Master Purchase Order.

6. Non-Exclusive:

This Master Purchase Order is non-exclusive. City does not guarantee any minimum purchase other than as provided herein.

7. Inspection and Acceptance:

City may inspect all goods/services prior to acceptance. Payment does not constitute acceptance. Vendor shall bear the cost of any inspection/testing that reveal goods/services that are defective or do not meet specifications. City’s failure to accept or reject goods/services shall not relieve Vendor from its responsibility for such goods/services that are defective or do not meet specifications nor impose liability on City for such goods/services. If any part of the goods/services are not acceptable to City, City may, in addition to any other rights it may have at law or in equity: (1) make a warranty claim; (2) repair and/or replace the goods or substitute other services at Vendor’s expense; or (3) reject and return the goods at Vendor’s cost and/or reject the services at Vendor’s expense for full credit. Any rejected goods/services are not to be replaced without written authorization from City, and any such replacement shall be on the same terms and conditions contained in this Master Purchase Order. Vendor shall perform all services in accordance with the standard of care exercised by highly competent vendors who perform like or similar services.

8. Shipping, Taxes and Other Credits and Charges:

All pricing is F.O.B. destination unless otherwise specified. Shipments must be marked with Vendor’s name, the Master Purchase Order number, and contain a delivery or packing slip. Vendor shall not impose any charges for boxing, crating, parcel post, insurance, handling, freight, express or other similar charges or fees. Vendor shall notify City in writing of any price decreases immediately, and City shall receive the benefit thereof on all unshipped items. Vendor shall comply with any additional delivery terms specified herein. Vendor shall be responsible for the cleanup and reporting of any contamination (environmental or otherwise) or spillage resulting from the delivery and/or unloading of goods within twenty-four (24) hours of the contamination or spillage or sooner if required by law. Vendor shall procure all permits and licenses; pay all charges, taxes and fees; and give all notices necessary and incidental to the fulfillment of this Master Purchase Order and all cost thereof have been included in the prices contained herein. City shall not be liable for the payment of taxes, late charges or penalties of any nature, except as required by D.R.M.C. § 20-107, et seq. The price of all goods/services shall reflect all applicable tax exemptions. City’s Federal Registration No. is 84-6000580 and its State Registration No. is 98-02890. Vendor shall pay all sales and use taxes levied by City on any tangible personal property built into the goods/services. Vendor shall obtain a Certificate of Exemption from the State of Colorado Department of Revenue prior to the purchase of any materials to be built into the goods/services and provide a copy of the Certificate to City prior to final payment.

9. Risk of Loss:

Vendor shall bear the risk of loss, injury or destruction of goods prior to delivery to City. Loss, injury or destruction shall not release Vendor from any obligation hereunder.

10. Invoice:

Each invoice shall include: (i) the Purchase Order number; (ii) individual itemization of the goods/services; (iii) per unit price, extended and totaled; (iv) quantity ordered, back ordered and shipped; (v) an invoice number and date; (vi) ordering department's name and "ship to" address; and (vii) agreed upon payment terms set forth herein.

11. Payment:

Payment shall be subject to City's Prompt Payment Ordinance D.R.M.C. § 20-107, et-seq. after City accepts the goods/services. Any other provision of this Agreement notwithstanding, in no event shall the City be liable for aggregate payments under this Master Purchase Order in excess of Forty Five Million Dollars (\$45,000,000.00). The Vendor acknowledges that any goods/services provided beyond those specifically described in **Exhibit A** are performed at Contractor's risk and without authorization from the City. City's payment obligations hereunder, whether direct or contingent, shall extend only to funds appropriated by the Denver City Council for the purpose of this Master Purchase Order, encumbered by the City after receipt of Vendor's invoice and paid into the Treasury of City. Vendor acknowledges that: (i) City does not by this Master Purchase Order, irrevocably pledge present cash reserves for payments in future fiscal years; and (ii) this Master Purchase Order is not intended to create a multiple-fiscal year direct or indirect debt or financial obligation of City. City may setoff against any payments due to Vendor any claims and/or credits it may have against Vendor under this Master Purchase Order.

12. Amendments/Changes:

Only the Manager of General Services or his delegate is authorized to change or amend this Master Purchase Order by a formal written change order. Any change or amendment that would cause the aggregate payable under this Master Purchase Order to exceed the amount appropriated and encumbered for this Master Purchase Order is expressly prohibited and of no effect. Vendor shall verify that the amount appropriated and encumbered is sufficient to cover any increase in cost due to changes or amendments. Goods/services provided without such verification are provided at Vendor's risk. The Vendor has no authority to bind City on any contractual matters.

13. Warranty:

Vendor warrants and guarantees to City that all goods furnished under this Master Purchase Order are free from defects in workmanship and materials, are merchantable, and fit for the purposes for which they are to be used. For any goods furnished under this Master Purchase Order which become defective within twelve (12) months (unless otherwise specified) after date of receipt by City, Vendor shall either, at City's election and to City's satisfaction, remedy any and all defects or replace the defective goods at no expense to City within seven (7) days of receipt of the defective goods or accept the defective goods for full credit and payment of any return shipping charges. Vendor shall be fully responsible for any and all warranty work, regardless of third party warranty coverage. Vendor shall furnish additional or replacement parts at the same prices, conditions and specifications delineated herein.

14. Indemnification/Limitation of Liability:

Vendor shall defend, indemnify, reimburse and hold harmless City (including but not limited to its employees, elected and appointed officials, agents and representatives) against any and all losses (to the extent caused by the Vendor or its subcontractors) including without limitation, loss of use and costs of cover) liability, demands for damages to person property, claims, therewith (including without limitation attorneys' fees) that arise out of or relate to any claim of infringement of patent, trademark, copyright, trade secret or other intellectual property right related to this Master Purchase Order or that are caused by or the result of any act or omission of Vendor, its agents, suppliers, employees, or representatives. To the extent permitted by law, neither party shall not be liable for any consequential, incidental, indirect, special, reliance, or punitive damages or for any lost profits or revenues, regardless of the legal theory under which such liability is asserted. This indemnity shall be interpreted to indemnify City for any acts or omissions of Vendor or its subcontractors either passive or active, except for the sole negligence or willful misconduct of City. In no event shall City's aggregate liability exceed the agreed upon cost for those goods/service that have been accepted by City under this Master Purchase Order. Vendor's duty to defend and indemnify City shall arise at the time written notice of the claim is first provided to City regardless of whether Claimant has filed suit on the Claim. Vendor will defend any and all Claims which may be brought or threatened against City and will pay on behalf of City any expenses incurred by reason of such Claims including, but not limited to, court costs and attorney fees incurred in defending and investigating such Claims or seeking to enforce this indemnity obligation. Such payments on behalf of City shall be in addition to any other legal remedies available to City and shall not be considered City's exclusive remedy. Notwithstanding anything contained in this Master Purchase Order to the contrary, City in no way limits or waives the rights, immunities and protections provided by C.R.S. § 24-10-101, et seq. This defense and indemnification obligation shall survive the expiration or termination of this Master Purchase Order. Insurance coverage requirements specified in this Agreement shall in no way lessen or limit the liability of the Vendor under the terms of this indemnification obligation. The Vendor shall obtain, at its own expense, any additional insurance that it deems necessary for the City's protection.

15. Termination:

City may terminate this Master Purchase Order, in whole or in part, at any time and for any reason immediately upon written notice to Vendor. In the event of such a termination, City's sole liability shall be limited to payment of the amount due for the goods/services accepted by City. Vendor acknowledges the risks inherent in this termination for convenience and expressly accepts them. Termination by City shall not constitute a waiver of any claims City may have against Vendor.

16. Interference:

Vendor shall notify the Director of Purchasing immediately of any condition that may interfere with the performance of Vendor's obligations under this Master Purchase Order and confirm such notification in writing within twenty-four (24) hours. City's failure to respond to any such notice shall in no way act as a waiver of any rights or remedies City may possess.

17. Venue, Choice of Law and Disputes:

Venue for all legal actions shall lie in the District Court in and for City and County of Denver, State of Colorado, and shall be governed by the laws of the State of Colorado as well as the Charter and Revised Municipal Code, rules, regulations, Executive Orders, and fiscal rules of City. All disputes shall be resolved by administrative hearing, pursuant to the procedure established by D.R.M.C. § 56-106. Director of Purchasing shall render the final determination.

18. Assignment/No Third Party Beneficiary:

Vendor shall not assign or subcontract any of its rights or obligations under this Master Purchase Order without the written consent of City. In the event City permits an assignment or subcontract, Vendor shall continue to be liable under this Master Purchase Order and any permitted assignee or subcontractor shall be bound by the terms and conditions contained herein. This Master Purchase Order is intended solely for the benefit of City and Vendor with no third party beneficiaries

19. Notice:

Notices shall be made by Vendor to the Director of Purchasing and by City to Vendor at the addresses provided herein, in writing sent registered, return receipt requested.

20. Compliance With Laws:

Vendor shall observe and comply with all federal, state, county, city and other laws, codes, ordinances, rules, regulations and executive orders related to its performance under this Master Purchase Order. City may immediately terminate this Master Purchase Order, in whole or in part, if Vendor or an employee is convicted, plead nolo contendere, or admits culpability to a criminal offense of bribery, kickbacks, collusive bidding, bid-rigging, antitrust, fraud, undue influence, theft, racketeering, extortion or any offense of a similar nature.

21. Insurance:

Vendor shall secure, before delivery of any goods/services, the following insurance covering all operations, goods and services provided to City. Vendor shall keep the required insurance coverage in force at all times during the term of the Master Purchase Order, or any extension thereof, during any warranty period, and for three (3) years after termination of this Master Purchase Order. The required insurance shall be underwritten by an insurer licensed to do business in Colorado and rated by A.M. Best Company as "A-"VIII or better. Each policy shall contain a valid provision or endorsement requiring notification to the City in the event any of the required policies be canceled or non-renewed before the expiration date thereof. Such written notice shall be sent to the parties identified in the Notices section of this Agreement. Such notice shall reference the City contract number listed on the signature page of this Agreement. Said notice shall be sent thirty (30) days prior to such cancellation or non-renewal unless due to non-payment of premiums for which notice shall be sent ten (10) days prior. If such written notice is unavailable from the insurer, contractor shall provide written notice of cancellation, non-renewal and any reduction in coverage to the parties identified in the Notices section by certified mail, return receipt requested within three (3) business days of such notice by its insurer(s) and referencing the City's contract number. If any policy is in excess of a deductible or self-insured retention, City must be notified by Vendor. Vendor shall be responsible for the payment of any deductible or self-insured retention. The insurance coverages specified in this Master Purchase Order are the minimum requirements, and these requirements do not lessen or limit the liability of Vendor. Risk Management reserves the right to require additional policies and/or limits based on agreement scope of work. Vendor shall provide a copy of this Master Purchase Order to its insurance agent or broker. Vendor may not commence services or work relating to the Master Purchase Order prior to placement of coverage. Contractor certifies that the attached certificate of insurance attached to the Master Purchase Order documents, preferably an ACORD certificate, complies with all insurance requirements of this Master Purchase Order. The City's acceptance of a certificate of insurance or other proof of insurance that does not comply with all insurance requirements set forth in this Master Purchase Order shall not act as a waiver of Vendor's breach of this Master Purchase Order or any of the City's rights or remedies under this Agreement. The City's Risk Management Office may require additional proof of insurance, including but not limited to policies and endorsements. Vendor's insurer shall name as Additional Insured to its Commercial General Liability and Business Auto Liability policies the City and County of Denver, its elected and appointed officials, employees and volunteers. Vendor's insurer shall waive subrogation rights against the City. All sub-contractors and sub-consultants (including independent contractors, suppliers or other entities providing goods/services required by this Master Purchase Order) shall be subject to all of the requirements herein and shall procure and maintain the same coverages required of Vendor. Vendor shall include all such entities as insureds under its policies or shall ensure that they all maintain the required coverages. Vendor shall provide proof of insurance for all such entities upon request by City. For Worker's Compensation Insurance, Vendor shall maintain the coverage as required by statute for each work location and shall maintain Employer's Liability insurance with limits of \$100,000 for each bodily injury occurrence claim, \$100,000 for each bodily injury caused by disease claim, and \$500,000 aggregate for all bodily injuries caused by disease claims. Vendor expressly represents to City, as a material representation upon

which City is relying, that none of the Vendor's officers or employees who may be eligible under any statute or law to reject Workers' Compensation Insurance shall effect such rejection during any part of the term of this Master Purchase Order, and that any such rejections previously effected, have been revoked. Vendor shall maintain Commercial General Liability coverage with limits of \$1,000,000 for each occurrence, \$1,000,000 for each personal and advertising injury claim, \$2,000,000 products and completed operations aggregate, and \$2,000,000 policy aggregate. Vendor shall maintain Business Auto Liability coverage with limits of \$1,000,000 combined single limit applicable to all owned, hired and non-hired vehicles used in performing services under this Master Purchase Order. For Commercial General Liability coverage, the policy must provide the following: (i) That this Master Purchase Order is an Insured Contract under the policy; (ii) Defense costs in excess of policy limits; (iii) A severability of interests, separation of insureds or cross liability provision; and (iv) A provision that coverage is non-contributory with other coverage or self-insurance provided by City. For claims-made coverage, the retroactive date must be on or before the first date when any goods or services were provided to City. Vendor must advise the City in the event any general aggregate or other aggregate limits are reduced below the required per occurrence limits. At their own expense, and where such general aggregate or other aggregate limits have been reduced below the required per occurrence limit, the Contractor will procure such per occurrence limits and furnish a new certificate of insurance showing such coverage is in force.

22. Severability:

If any provision of this Master Purchase Order, except for the provisions requiring appropriation and encumbering of funds and limiting the total amount payable by City, is held to be invalid, illegal or unenforceable by a court of competent jurisdiction, the validity of the remaining portions or provisions shall not be affected if the intent of City and Vendor can be fulfilled.

23. Survival:

All terms and conditions of this Master Purchase Order which by their nature must survive termination/expirations shall so survive. Without limiting the foregoing, Vendor's insurance, warranty and indemnity obligations shall survive for the relevant warranty or statutes of limitation period plus the time necessary to fully resolve any claims, matters or actions begun within that period. Bonds shall survive as long as any warranty period.

24. No Construction Against Drafting Party:

No provision of this Master Purchase Order shall be construed against the drafter.

25. Status of Vendor/Ownership of Work Product:

Vendor is an independent contractor retained on a contractual basis to perform services for a limited period of time as described in Section 9.1.1E(x) of the Charter of City. Vendor and its employees are not employees or officers of City under Chapter 18 of the D.R.M.C. for any purpose whatsoever. All goods, deliverables, hardware, software, plans, drawings, reports, submittals and all other documents or things furnished to City by Vendor shall become and are the property of City, without restriction.

26. Records and Audits:

Vendor shall maintain for three (3) years after final payment hereunder, all pertinent books, documents, papers and records of Vendor involving transactions related to this Master Purchase Order, and City shall have the right to inspect and copy the same.

27. Remedies/Waiver:

No remedy specified herein shall limit any other rights and remedies of City at law or in equity. No waiver of any breach shall be construed as a waiver of any other breach.

28. No Discrimination in Employment:

Vendor shall not refuse to hire, discharge, promote or demote, or to discriminate in matters of compensation against any person otherwise qualified, solely because of race, color, religion, national origin, gender, age, military status, sexual orientation, marital status, or physical or mental disability; and Vendor shall insert the foregoing provision in any subcontracts hereunder.

29. Use, Possession or Sale of Alcohol or Drugs:

Vendor shall cooperate and comply with the provisions of Executive Order 94. Violation may result in City terminating this Master Purchase Order or barring Vendor from City facilities or from participating in City operations.

30. Conflict of Interest:

No employee of City shall have any personal or beneficial interest in the goods/services described in this Master Purchase Order; and Vendor shall not hire or contract for services any employee or officer of City which would be in violation of City's Code of Ethics, D.R.M.C. §2-51, et seq. or the Charter §§ 1.2.8, 1.2.9, and 1.2.12.

31. Advertising and Public Disclosure:

The Vendor shall not include any reference to the Master Purchase Order or to services performed or goods purchased pursuant to the Master Purchase Order in any of the Vendor's advertising or public relations materials without first obtaining the written approval of the Director of Purchasing.

32. No Employment of Illegal Aliens to Perform Work Under The Agreement:

a. This Agreement is subject to Division 5 of Article IV of Chapter 20 of the Denver Revised Municipal Code, and any amendments (the "Certification Ordinance").

b. The Contractor certifies that:

- (1) At the time of its execution of this Agreement, it does not knowingly employ or contract with an illegal alien who will perform work under this Agreement.

(2) It will participate in the E-Verify Program, as defined in § 8-17.5-101(3.7), C.R.S., to confirm the employment eligibility of all employees who are newly hired for employment to perform work under this Agreement.

c. The Contractor also agrees and represents that:

- (1) It shall not knowingly employ or contract with an illegal alien to perform work under the Agreement.
- (2) It shall not enter into a contract with a subconsultant or subcontractor that fails to certify to the Contractor that it shall not knowingly employ or contract with an illegal alien to perform work under the Agreement.
- (3) It has confirmed the employment eligibility of all employees who are newly hired for employment to perform work under this Agreement, through participation in the E-Verify Program.
- (4) It is prohibited from using the E-Verify Program procedures to undertake pre-employment screening of job applicants while performing its obligations under the Agreement, and that otherwise requires the Contractor to comply with any and all federal requirements related to use of the E-Verify Program including, by way of example, all program requirements related to employee notification and preservation of employee rights.
- (5) If it obtains actual knowledge that a subconsultant or subcontractor performing work under the Agreement knowingly employs or contracts with an illegal alien, it will notify such subconsultant or subcontractor and the City within three (3) days. The Contractor will also then terminate such subconsultant or subcontractor if within three (3) days after such notice the subconsultant or subcontractor does not stop employing or contracting with the illegal alien, unless during such three-day period the subconsultant or subcontractor provides information to establish that the subconsultant or subcontractor has not knowingly employed or contracted with an illegal alien.
- (6) It will comply with any reasonable request made in the course of an investigation by the Colorado Department of Labor and Employment under authority of § 8-17.5-102(5), C.R.S, or the City Auditor, under authority of D.R.M.C. 20-90.3.

d. The Contractor is liable for any violations as provided in the Certification Ordinance. If Contractor violates any provision of this section or the Certification Ordinance, the City may terminate this Agreement for a breach of the Agreement. If the Agreement is so terminated, the Contractor shall be liable for actual and consequential damages to the City. Any such termination of a contract due to a violation of this section or the Certification Ordinance may also, at the discretion of the City, constitute grounds for disqualifying Contractor from submitting bids or proposals for future contracts with the City.

33. Prevailing Wages

This Master Purchase Order shall be subject to the following provisions concerning prevailing wages.

- a. The minimum wages to be paid for every class of labor, mechanics and worker shall be not less than the scale of wages from time to time determined to be the prevailing wages.
- b. The Vendor or his/her subcontractor shall pay mechanics, laborers and workers employed directly upon the site of the work the full amounts accrued at time of payment, computed at wage rates not less than those stated or referenced in the specifications, and any addenda thereto, on the actual date of proposal opening, or in effect on the date of grant of permit for performance of such work under D.R.M.C. Section 49-171 et seq., or on the date of the written Master Purchase Order for contracts let by informal procedure under D.R.M.C. Section 20-63(b), regardless of any contractual relationship which may be alleged to exist between the vendor or subcontractor and such laborers, mechanics and workers.
- c. The vendor and subcontractors to pay all workers, mechanics and other laborers at least once a week the full amounts of wages accrued at the time of payment except that the vendor and subcontractor shall make such payments to non-construction workers such as janitorial or custodial workers at least twice per month.
- d. The vendor shall post in a prominent and easily accessible place at the site of the work the scale of wages to be paid by the vendor and all subcontractors working under the vendor.
- e. If the vendor or any subcontractor shall fail to pay such wages as are required by the contract, the Auditor shall not approve any warrant or demand for payment to the vendor until the vendor furnishes the Auditor evidence satisfactory to the Auditor that such wages so required by the contract have been paid.
- f. The vendor shall furnish to the Auditor each week during which work is in progress under the contract, a true and correct copy of the payroll records of all workers, laborers and mechanics employed under the contract, either by the vendor or subcontractors.
- g. The copy of the payroll record shall be accompanied by a sworn statement of the vendor that the copy is a true and correct copy of the payroll records of all mechanics, laborers or other workers working under the contract either for the vendor or subcontractors, that payments were made to the workers, laborers and mechanics as set forth in the payroll records, that no deductions were made other than those set forth in such records, and that all workers, mechanics and other laborers employed on work under the contract, either by the vendor or by any subcontractor, have been paid the prevailing wages as set forth in the contract specifications.
- h. If any laborer, worker or mechanic employed by the vendor or any subcontractor under the contract has been or is being paid a rate of wages less than the rate of wages required by the contract to be paid as aforesaid, the City may, by written notice to the vendor, suspend or terminate the vendor's right to proceed with the work, or such part of the work as to which

there has been a failure to pay the required wages, and in the event of termination may prosecute the work to completion by contract or otherwise, and the vendor and any sureties shall be liable to the City for any excess costs occasioned the City thereby.

34. MBE/WBE Procurement Goals– Provision For Contracts/Master Purchase Orders:

- A. This Agreement [Master Purchase Order] is subject to all applicable provisions of Article V, of Chapter 28, Denver Revised Municipal Code (D.R.M.C.), designated as §§ 28-117 –137 and 28-152 – 28-158, D.R.M.C., (referred to in this Agreement [Master Purchase Order] as the “MBE/WBE/SBE Purchasing Ordinance”) and any Rules or Regulations promulgated pursuant thereto. The Contractor [Consultant][Vendor] identified in its bid [proposal] the participating MBE and/or WBE firms that will be used to satisfy the procurement goal, whether as a self-performing bidder or proposer, a subcontractor, or member of a joint venture and a total participation level by such firms of 1.34%. The procurement goal for MBE/WBE participation established for this Agreement by the Division of Small Business Opportunity (DSBO) is 1% on installed only.
- B. Under §28-132, D.R.M.C., the Contractor [Consultant][Vendor] has an ongoing, affirmative obligation to maintain for the duration of this Agreement [Master Purchase Order], at a minimum, compliance with its originally achieved level of MBE and WBE participation upon which this Agreement [Master Purchase Order] was awarded, unless the City initiates a material alteration to the scope of work affecting MBEs or WBEs performing on this Agreement [Master Purchase Order] through contract amendment or otherwise as set forth in §28-133, D.R.M.C. The Contractor [Consultant][Vendor] acknowledges that:
1. It must establish and maintain records and submit regular reports, as required, which will allow the City to assess progress in achieving the M/WBE participation goal.
 2. If any contract modifications are issued under the Agreement [Master Purchase Order], the Contractor [Consultant][Vendor] shall have a continuing obligation to immediately inform DSBO in writing of any agreed upon increase or decrease in the scope of the procurement of such contract, upon any of the bases discussed in §28-133, D.R.M.C., regardless of whether such increase or decrease in scope of the procurement has been reduced to writing at the time of notification.
 3. If any contract modifications are issued under the contract, that include an increase in the amount of covered goods or scope of covered services under the Agreement [Master Purchase Order], whether by amendment or otherwise which increases the dollar value of the contract, whether or not such change is within the scope of performance by an M/WBE at the time of contract award, such contract modification shall be immediately submitted to DSBO for notification purposes. Those amendments or other contract modifications that involve a changed scope of goods or services that cannot be performed by existing project subcontractors or by the Contractor [Consultant][Vendor] shall be subject to a goal for M/WBEs equal to the original goal on the contract which was included in the bid or proposal. The Contractor [Consultant][Vendor] shall satisfy such goal with respect to such changed scope of procurement by soliciting new M/WBEs in accordance with §28-133, D.R.M.C., as applicable, or the Contractor [Consultant][Vendor] must show each element of modified good faith set out in §28-135(d), D.R.M.C. The Contractor [Consultant][Vendor] shall supply to the director the documentation described in §28-135(d), D.R.M.C. with respect to the increased dollar value of the contract [master purchase order].
 4. Failure to comply with these provisions may subject the Contractor [Consultant][Vendor] to sanctions set forth in the MBE/WBE/SBE Purchasing Ordinance. Should any questions arise regarding specific circumstances, the Contractor [Consultant][Vendor] must consult the MBE/WBE/SBE Purchasing Ordinance or contact the designated DSBO representative at (720) 913-1999.

This Master Purchase Order is acknowledged and agreed to by:

Vendor Name: John Bean Technologies
(Company Name)

By: 
(Authorized Signature)

Print Name: Curtis Corbridge

Title: Site Controller

Date: 8/12/2015

City & County of Denver, Purchasing Division

By: 

Print Name: Curtis Subia

Title: Senior Buyer

Date: 8/13/15

EXHIBIT "A"

Vendor: John Bean Technologies Corporation
dba JBT AeroTech, Jetway Systems
Title: Passenger Loading Bridges for Denver International Airport
Master Purchase Order No.: 0823A0115

It is recommended that you use your Master Purchase Order No. – 0823A0115, in all future correspondence or other communications. Individual Purchase Orders will be issued for orders. All invoices and billing inquiries must refer to the specific Purchase Order for the order.

Description of the goods, and services related thereto, being purchased and pricing:

A.1 SCOPE OF WORK

JBT as the successful proposer, (vendor), is to provide and install when required, Passenger Loading Bridges (PLB) at Denver International Airport (DEN). This award is to provide for the replacement of PLBs throughout the airport. The first year of the term contract is anticipated to replace six (6) PLBs with additional bridges in subsequent years. The anticipated number of bridges to be replaced through the program is 27-30. These replacements will be subject to identification and budgeting processes and will be released/identified to the vendor by DEN annually.

The intent of this Master Purchase Order is to provide bridges needed by the City as required. This MPO may be used to purchase any bridge offered by the vendor.

The scope of work may include installation and all work and supplies that are required to bring the bridge into full operation. Pricing on the PLBs includes all sundries, equipment, and supplies necessary to bring the bridge into full operation. All installation is simple replacement, no change in concrete, building envelope (outside of bridges) and/or typical heavy construction is anticipated. Vendor is responsible for all permits required for installation, if the installation is utilized.

Prior to order placement, the City will approve all shop drawings and Manufacturer's Job Orders to ensure the specifications before construction of the equipment.

The City may also use this agreement/Master Purchase Order to fulfill orders for PLBs that may utilize installation by general contractors and City employees. These orders for bridges will not include installation but must include all sundries, equipment, and supplies necessary to bring the bridge into full operation.

The vendor will be responsible for the disposal of the bridges. This disposal will include removal of the bridge, set it on a low boy, and take it to the DEN storage yard on 88th Ave. DEN Employees will salvage parts off them. At the end of the replacement season, a one-time crane will be required pick up the remaining parts and haul them to a scrap yard, the City reserves the right to determine the scrap yard.

A.2 SPECIFICATIONS

The City Specifications for the PLB's are attached to this document as **Exhibit B**. All bridges supplied under this agreement shall meet or exceed the attached specifications. Additional specifications are included in **Exhibit C**.

A.3 INSTALLATION PROVISIONS:

Vendor shall be responsible for obtaining any and all permits (including the cost thereof) required to perform this installation. The installation shall be in complete compliance with City of Denver Building and Fire Codes.

The City shall at all times have the right to inspect the work and materials used in the installation of the Passenger Loading Bridges. The vendor shall furnish all reasonable aid and assistance required for the proper examination of the work and all parts thereof. The vendor shall regard and obey directions and instructions of the City's Manager of Aviation or his/her authorized inspectors, when such directions or instructions are consistent with the plans and specifications for the Passenger Loading Bridges to be installed; provided, however, that should the vendor object to any order given by the City's authorized inspector, they may make a written application to the City's Manager of Aviation for his/her decision, which decision shall be final and conclusive. Such inspection shall not relieve the vendor from the obligation to install the Passenger Loading Bridges strictly in accordance with the approved plans and specifications or any approved modification thereof.

PROTECTION OF PROPERTY: The vendor shall assume full responsibility and expense for the protection of all public and private property, structures, water mains, sewers, utilities, etc., both above and below ground, at or near the site or sites of the work being performed under the contract, or which are in any manner affected by the prosecution of the work or the transportation of men and materials in connection therewith. The Vendor shall give reasonable written notice in advance to the Department of the City having charge of any property or utilities owned by the City and to other owner or owners of public or private property or utilities when they will be affected by the work to be performed under the contract, and shall make all necessary arrangements with such department, departments, owner or owners for the removal and replacement or protection of such property or utilities.

METHODS OF OPERATION: Installation work started by the vendor on any unit of his/her contract must be continuously and actively prosecuted with an optimum complement of workmen and equipment to expedite completion in the shortest possible time. The Vendor shall organize to do this installation eight hours per day from Monday to Friday inclusive in each week, excluding legal holidays.

All work shall be accomplished by workers proficient and experienced in the trades required and in an orderly and responsible manner in accordance with recognized standards and the plans and specifications.

Premises shall be kept clean and neat. Materials, scrap and equipment not having further use at the site shall be promptly removed from the job site. Disposal of vendor's waste materials in the City's containers is prohibited unless prior permission has been granted.

OSHA GUIDELINES: The vendor shall be familiar with and operate within the guidelines as set forth by the Occupational Safety and Health Act.

For all operations requiring the placement and movement of the Vendor's equipment, vendor shall observe and exercise and compel his/her employees to observe and exercise all necessary caution and discretion so as to avoid injury to persons, damage to property of any and all kinds, and annoyance to or undue interference with the movement of the public and City personnel.

All ladders, scaffolding or other devices used to reach the surface of objects not otherwise accessible, shall be of sound construction, firm and stable, and shall be maintained in good condition. All such equipment shall be moved onto the areas where they are required, placed, shifted where necessary, and removed from the areas in such manner as to provide maximum safety to persons and property and cause the least possible interference with the normal usage of such areas by the public and City personnel.

VENDOR'S PERFORMANCE: Vendor shall furnish all necessary labor, tools, equipment and supplies to perform the required services at the City facilities designated. The Manager of General Services, the Manager of Aviation or their authorized representatives will decide all questions which may arise as to the quality and acceptability of any work performed under the contract. If, in the opinion of the above or his/her authorized representative, performance becomes unsatisfactory, the City shall notify the vendor.

The vendor will have five (5) days from the time to correct any specific instances of unsatisfactory performance. In the event the unsatisfactory performance is not corrected within the time specified above, the City shall have the immediate right to complete the work to its satisfaction and shall deduct the cost to cover from any balances due or to become due the vendor. Repeated incidences of unsatisfactory performance will result in cancellation of the agreement for default.

A.4 PERFORMANCE INTERFERENCE:

Vendor shall notify the Project Manager immediately of any occurrence or conditions that interfere with the full performance of the contract, and confirm it in writing within twenty-four (24) hours.

A.5 PATENTS:

Seller agrees to defend the City and County of Denver at seller's own expense, in all suits, actions or proceedings in which the City and County of Denver is made a defendant for actual or alleged infringement of any United States of America or foreign letters patent resulting from the City and County of Denver's use of the goods purchased as a result of this Invitation for Proposal. Seller further agrees to pay and discharge any and all judgments or decrees which may be rendered in any such suit, action or proceeding against the City and County of Denver.

Seller agrees to indemnify and hold harmless the City and County of Denver from any and all license, royalty and proprietary fees or costs, including legal costs, which may arise out of the City and County of Denver's purchase and use of goods supplied by the seller.

It is expressly agreed by seller that these covenants are irrevocable and perpetual.

A.6 LIQUIDATED DAMAGES:

If the vendor fails to deliver the supplies or perform the services within the time specified in his/her Purchase Order or Contractual Agreement, or any extension thereof, the vendor will pay the actual damages to the City for the delay. This will be calculated by the average amount of revenue per gate as shown historically for that gate. The City may terminate this Master Purchase Order or Contractual Agreement in whole or in part as provided in the "Default" provision. In that event, the vendor shall be liable for such liquidated damages accruing until such time as the City may reasonably obtain delivery or performance of similar supplies and services. The vendor shall not be charged with liquidated damages when the delay arises out of causes beyond the control and without the fault or negligence of the vendor.

A.7 AIRPORT SECURITY:

It is a material requirement of this Purchase Order or Contractual Agreement that the Vendor shall comply with all rules, regulations, written policies and authorized directives from the City and/or the Transportation Security Administration with respect to Airport security. The Vendor shall conduct all of its activities at the Airport in compliance with the Airport security program, which is administered by the Security Section of the Airport Operations Division, Department of Aviation. Violation by the Vendor or any of its employees, subcontractors, and vendors of any rule, regulation, or authorized directive from the City or the Transportation Security Administration with respect to Airport Security shall be grounds for immediate termination by the City of this Contract for cause.

The Vendor shall promptly upon notice of award of this Purchase Order or Contractual Agreement, meet with the Airport's Assistant Security Manager to establish badging and vehicle permit requirements for Vendor's operations under this Contract. The Vendor shall obtain the proper access authorizations for all of its employees, subcontractors, and vendors who will enter the Airport to perform work or make deliveries, and shall be responsible for each such person's compliance with all Airport rules and regulations, including without limitation

those pertaining to security. Any person who violates such rules may be subject to revocation of his/her access authorization. The failure of the Vendor or any subcontractor to complete any required services hereunder shall not be excused on account of the revocation for good cause of access authorization of any person.

The security status of the Airport is subject to change without notice. If the security status of the Airport changes at any time during the term of this Purchase Order or Contractual Agreement, the Vendor shall take immediate steps to comply with security modifications which occur as a result of the changed status. The Vendor may at any time obtain current information from the Airport Security Office regarding the Airport's security status in relation to the Vendor's operations at the Airport.

The Vendor shall return to the City at the expiration or termination of this Contract, or upon demand by the City, all access keys or access badges issued to it for any area of the Airport, whether or not restricted. If the Vendor fails to do so, the Consultant shall be liable to reimburse the City for all the City's costs for work required to prevent compromise of the Airport security system. The City may withhold funds in the amount of such costs from any amounts due and payable to the Vendor under this Purchase Order or Contractual Agreement.

Laws, Regulations, Taxes and Permits

The Vendor shall procure all permits and licenses, pay all charges, taxes and fees and give all notices necessary and incidental to the due and lawful prosecution of the work. All costs thereof shall be deemed to be included in the prices proposed for the work.

The Vendor, at all times, shall observe and comply with all federal, state, county, city and other laws, codes, ordinances, rules and regulations in any manner affecting the conduct of the work.

Without limiting the foregoing, the Vendor shall establish appropriate procedures and controls so that services under this Contract will not be performed by using any alien who is not legally eligible for such employment under United States Immigration laws. Failure to comply with this condition satisfactorily may cause the City to terminate this Contract.

A.8 COOPERATIVE PURCHASING:

The City and County of Denver encourages and participates in cooperative purchasing endeavors undertaken by or on behalf of other governmental jurisdictions, pursuant to Denver Revised Municipal Code Sec. 20-64.5. To the extent other governmental jurisdictions are legally able to participate in cooperative purchasing endeavors, the City and County of Denver supports such cooperative activities. Further, it is a specific requirement of this proposal or Request for Proposal that pricing offered herein to the City and County of Denver may be offered by the vendor to any other governmental jurisdiction purchasing the same products.

The vendor(s) must deal directly with any governmental agency concerning the placement of purchase orders, freight charges for destinations outside of the Denver Metro area, contractual disputes, invoicing, and payment. The City and County of Denver shall not be liable for any costs, damages incurred by any other entity.

A.9 F.O.B. POINT:

Prices quoted shall be F.O.B. Denver, CO, unloaded and installed.

A.10 ASSIGNMENT OF PURCHASE ORDER OR CONTRACT:

A vendor may not assign or otherwise transfer any of its rights or obligations under any purchase order or contract made and entered into pursuant to a City and County of Denver proposal without the prior written approval of the Manager of General Services or his/her representative.

A.11 CATALOG AND PRICE LISTS:

Vendor must provide with the proposal a copy of the current manufacturer's price list or access to website and catalog that will be in effect at the commencement of the contract and from which the discounts offered will be evaluated.

Upon request, the vendor shall provide additional sets or accesses of manufacturer's product catalogs and parts price lists.

A.12 PAYMENT CONDITIONS:

Final Inspection: Should final inspection reveal that work accomplished under any resulting Purchase Order or Contractual Agreement is incomplete, or has not been made in accordance with drawings, specifications and authorized changes thereto, then the vendor shall be required to correct or complete the project before final payment will be made.

Final payment for work accomplished will not be considered until final inspection and approval by the City.

A.13 VENDOR PERFORMANCE MANAGEMENT:

The Purchasing Department may administer a vendor performance management program as part this proposal and resulting contract. The purpose of this program is to create a method for documenting and advising the Purchasing Department of exceptional performance or any problems related to the purchased goods and services.

Awarded vendors are required to furnish a performance report to the buyer on an annual basis, no later than the anniversary date of the applicable Master Purchase Order or City Contract, providing at a minimum the following information:

FOR GOODS

- Total dollar value of goods
- Total number of transactions

FOR SERVICES

- Total dollar value of services (including installation)
- Total number of transactions
- Average response time after receipt of order from the City
- Average time for job completion

Additionally, the vendor may be required to adhere to a vendor management program as requested by DIA.

A.14 CHANGES:

The City will not consider change orders or amendments unless it is deemed a change in the original scope of the project. All items not itemized in the pricing above which are instrumental to completing the project will be at the cost of the vendor to supply at no additional charge to the City.

A.15 PRICING:

All prices quoted shall be firm and fixed for the specified contract period. Prices may be adjusted based on the formula in Section C.4 Pricing Updates Below.

In the event the market price on any item is reduced during the period of the resulting Purchase Order or Contractual Agreement, the successful vendor for that item shall reduce the price to the City accordingly.

A.16 PRICING UPDATES FOR BRIDGES AND INSTALLTION:

Due Dates for Yearly Pricing Updates PLBs and Installation only.

PRICING UPDATE DUE DATE	PRICING PERIOD
December 15 th	January 1 through December 31

The vendor must provide a complete template that includes both items with price changes as well as items where changes are not requested. Items with price increases must be clearly identified.

Price Escalation Protocol

The City and awarded vendor mutually agree to escalate/ de-escalate pricing as evidenced by the Producer Price Index (PPI), Scheduled Air Transportation as maintained by the United States Department of Labor, Bureau of Labor Statistics, or its successor using as a base period, June 2015. Website (as 5/07/2015): www.bls.gov/ppi

Producer Price Index Industry Data
Series ID: PCU4811

Under no circumstances will any increase in pricing exceed 3% per year.

Remainder of page left blank intentionally.

A.17 ITEMS:

The below list is subject to budget constraints. Actual bridges ordered via purchase order will be the only bridges accepted. Additional bridges shall be quoted in line with the pricing below and must be of the same quality. Installation will be decided on a per bridge basis and will be included on the purchase order if required.

2015 Bridges (Anticipated)

Bridge Number	Manufacturer	Model Number	Bridge Price	Install Price	Total
A49	Stearns	A15-67/128	\$ 469,998.50	\$ 123,760.33	\$ 593,758.83
A31	Stearns	A13-65/122	\$ 463,884.50	\$ 123,949.33	\$ 587,833.83
B46	Stearns	A11-63/116	\$ 442,696.50	\$ 96,122.33	\$ 538,818.83
C36	JBT	A3-60/119-125R	\$ 450,244.50	\$ 133,542.33	\$ 583,786.83
C33	JBT	A3-58/110-125R	\$ 443,024.50	\$ 133,542.33	\$ 576,566.83
C34	JBT	A3-58/110-125R	\$ 443,024.50	\$ 133,542.33	\$ 576,566.83

2016 Bridges (Anticipated)

Bridge Number	Manufacturer	Model Number	Bridge Price	Install Price	Total
B60	JBT	A3 58/110-125R	\$ 464,057.00	\$ 99,331.83	\$ 563,388.83
B52	Stearns	A11 63/116	\$ 455,477.00	\$ 99,331.83	\$ 554,808.83
B47	Stearns	A13 65/122	\$ 456,151.00	\$ 108,581.83	\$ 564,732.83
B42B	Stearns	A07 59/104	\$ 450,883.00	\$ 108,581.83	\$ 559,464.83
A44	Stearns	A15 67/128	\$ 457,456.00	\$ 110,122.83	\$ 567,578.83
C45	JBT	A3 60/119-125R	\$ 463,758.00	\$ 110,122.83	\$ 573,880.83

Additional pricing allowed is as follows:

Commissioning: \$3,267.00 per bridge

Training: \$2,490.00 per phase

Permits: \$2,326.00 per bridge (if required)

SECTION 147310 - APRON DRIVE PASSENGER BOARDING BRIDGES

PART 1 - GENERAL

1.1 RELATED DOCUMENTS

- A. Drawings and general provisions of the Contract, including General and Supplementary Conditions and Division 01 Specification Sections, apply to this Section.

1.2 SUMMARY

- A. This project replaces six (6) aging Passenger Loading Bridges (PLBs) currently in service. These bridges are nearing the end of their useful life as they are 20+ years old. The scope of this project includes removal of the existing bridges, fabrication of new bridges per this specification, and installation of the new bridges in the current locations.

A. SECTION INCLUDES

1. Passenger Boarding Bridges
2. Walkways
3. Rotundas,
4. Removal and Re-installation of the existing Pre-conditioned Air Units. (Capture and reuse glycol)
5. Removal and re-installation of the 400 Hz aircraft power units.

B. RELATED REQUIREMENTS

1. Division 3 Concrete: Installing inserts, sleeves and anchors in concrete.
2. Division 5 Metals:
 - a. Providing steel framing supports, auxiliary support steel and steel brackets.
 - b. Refer to Technical Specification Section 059990 "Welding" for required welding submittals for field welding only. All shop welding shall be of good commercial quality.
3. Division 9 Finishes: Providing finish wall and finish flooring, painting unfinished and shop primed ferrous materials.
4. Division 11; Section 011400 "Work Sequence and Constraints" for other Installation Requirements.
5. Division 23: Heating, Ventilation and Air Conditioning: Ductwork.
6. FIRE SPRINKLERS
7. Division 26 Electrical: Electrical systems and components.
 - a. Providing electrical service to PBB and walkways, including fused disconnect switches.
 - b. Emergency power supply, transfer switch and auxiliary contacts.
 - c. Heat and smoke sensing devices.
 - d. Convenience outlets.

8. Division 27 Communications: Communications systems and components

- C. Alternates: Refer to Division 01 Section 012300 "Alternates" for description of Work in this Section affected by Alternates.

1.3 ACTION SUBMITTALS

- A. General: Submit required items in accordance with General Contract Conditions and Division 01 Specification Sections.
- B. Product Data: Provide capacities, sizes, performances, operations, safety features, finishes, and similar information.
- C. Shop Drawings: Show plans, elevations, sections, and accurately scaled details indicating coordination with building structure, relationships with other construction, and location of equipment. Show stop locations. Indicate variations from specified requirements, maximum dynamic and static loads imposed on building structure at points of support, and maximum and average power demands. Include,
1. Graphics / signage details.
 2. Foundation drawings (If required for new work).
 3. Electrical drawings.
 4. Graphics / signage details.
 5. Paint finishes.
 6. Preconditioned air and 400 Hz brackets and connection details for tie-in to existing monitoring system
- D. Samples for Verification: Provide samples for exposed finishes; 3-inch square samples of sheet materials; and 4-inch lengths of running trim members.
- E. Spare Parts: Recommended spare parts list with current prices shall be furnished not less than 45 days prior to arrival of a bridge.

1.4 INFORMATIONAL SUBMITTALS

- A. Regulatory Qualifications:
1. NFPA 415
 2. NFPA 70 National Electrical Code
 3. FAA Advisory Circular No. 150/5220-21C (6/29/2012)

1.5 CLOSEOUT SUBMITTALS

- A. Operation and Maintenance Data: For PBBs to include in operation and maintenance manuals.
- B. Inspection and Acceptance Certificates, letters, and Operating Permits: As required by

authorities having jurisdiction.

- C. "As Built" Plans: Contractor shall submit an As-Built model in the current Revit format in accordance with DSM 12 requirements, and in Adobe Acrobat 6.0 (bookmarked and free of security), in hard copy and electronic format

1.6 PREINSTALLATION MEETINGS

- A. Pre-installation Conference: Conduct conference at Project site to comply with requirements Division 1 Section "Project Meetings."
- B. Preinstallation Examination Report: Indicating dimensional discrepancies and conditions detrimental to performance or indicating that dimensions and conditions were found to be satisfactory.

1.7 QUALITY ASSURANCE

- A. Manufacturer: Shall be qualified in manufacturer of PBB and walkways.
- B. Installer: Shall have five years of certified experience in installer PBB and walkways.

1.8 DELIVERY, STORAGE, AND HANDLING

- A. Manufacturing will deliver materials, components and equipment to the AOA gate. Contractor is responsible to escort equipment, unload, and provide secure and safe storage on job site.

1.9 WARRANTY

- A. Submit manufacturer's standard written warranty to repair or replace defects in materials and workmanship not due to ordinary wear and tear or improper use.
 - 1. Warranty Period: 2 years from date of substantial completion.

1.10 MAINTENANCE

- A. Provide qualified technical and service personnel on-call within twenty-four (24) hours for maintenance calls.
 - 1. Maintenance Period: Sixty (60) days from date of substantial completion.

1.11 DISPOSAL

- A. Any PBB that is scheduled to be removed and intended for disposal shall be disposed of by the Contractor off Airport property at an approved disposal site. Under no conditions should a PBB intended for disposal be disposed of on-site.

1.12 CONSTRUCTION WASTE MANAGEMENT

- A. Construction waste shall be managed in accordance with provisions of Section 017419 "Construction Waste Management and Disposal". Documentation shall be submitted to satisfy the requirements of that Section.

PART 2 - PRODUCTS

2.1 OWNER FURNISHED EQUIPMENT

- A. Owner Furnished Equipment: Prior to removal, Contractor shall inspect and document condition of existing equipment to be re-used, including:
1. PC Air unit
 2. 400 Hz Unit
 3. Cable hoist

2.2 GROUT

- A. Grout for Anchor Bolts

2.3 APRON DRIVE PASSENGER BOARDING BRIDGE AND WALKWAY

- A. Acceptable Manufacturers: Subject to compliance with requirements, provide one of the following:
1. JBT AeroTech
 2. ThyssenKrupp Airport Systems Inc.
 3. Ameribridge
 4. Or approved equal.

- B. Materials

Component:	ASTM Grade or Equivalent (Min. Properties):
Structural Plate	ASTM-A35-70A
Structural Steel and Shapes	ASTM-A36-69
Steel Tube	ASTM-A36-69
Steel Pipe	ASTM-A53-B
Steel Sheet	ASTM-A570-72 F or ASTM-A569
T-1 Pins	ASTM-A5-4-64 F or ASTM-A517-64 F
Hinge Pins	SAE 1018 or AISI 1018 (American Iron and Steel Institute)
Bolts – Standard	ASTM-A307
Bolts – High Strength	ASTM-A325 or SAE Grade 8

- C. General In Service Requirements

1. The PBBs shall be of telescoping three-tunnel design with corrugated sides
 - a. Model: A3-68/141 or equivalent.
 - b. Sizes
 - a) Gate A49 – A15-67/128
 - b) Gate B46 – A11-63/116
 - c) Gate B52 – Unknown Model
 - d) Gate B60 – Unknown Model
 - e) Gate C33 – A3-58/110

f) Gate C34 – A3-58/110

2. The bridge shall be designed to conform to all applicable Federal, State of Colorado, and City and County of Denver codes and regulations, including applicable Memoranda of Understanding between the City and County of Denver Building Department and DIA.
3. The PBB shall be designed in accordance with good engineering practices and the standards developed and adopted by the passenger boarding bridge industry. Particular attention shall be given to keeping components simple, rugged and easily accessible for routine maintenance, including lubrication, component exchange and ease of adjustment. All access panels and openings shall be sized to accommodate the component being changed or adjusted, as well as the equipment and personnel necessary to accomplish the work. Particular attention shall be given to keeping components simple, rugged and easily accessible for routine maintenance, lubrication, component exchange and adjustment.
4. Modular components: Provide for rapid corrective maintenance of malfunctioning elements through use of standardized modular components, which are readily available in the continental U.S. Allowance must be made for convenient access to components critical to the operation of the passenger loading bridge.
5. The bridge head/cab shall be equipped with canopies, side curtains, and floor bumpers and shall be capable of docking with aircraft without scratching or damaging the aircraft fuselage when contact is made, with aircraft parked within plus or minus 1 foot (0.3 m) in any direction from the position marked on the apron.
6. If special tools are required for routine maintenance, one (1) set shall be furnished by the Contractor for each year of the Project.
7. PBB and WW shall be designed to drain and not to accumulate water.

2.4 SAFETY FEATURES

- A. All equipment shall be designed to be fail-safe and all controls, which regulate bridge motions (i.e., horizontal travel, vertical travel, and cab rotation), shall be of the dead-man type.
- B. All operating mechanisms, i.e. horizontal and vertical drive, cab rotation, etc. shall be designed so that the drive mechanism is locked when power fails or is shut off.
- C. Positive stops shall be provided to prevent over-travel where any component might become disengaged from its guiding or restraining component. The positive stop shall be in addition to all limit switches provided to restrict over-travel under normal operating conditions, including bogie steering motions.
- D. All sheared or sharp metal edges shall be deburred or broken. All exposed metal corners shall have radii.

2.5 PERFORMANCE / DESIGN CRITERIA

- A. Design Loads

1. Structural Loads: The PBB and WW shall accommodate the combination that imposes the most adverse loading condition. In addition to the dead loads and strain caused by movement, the PBB and WW shall support:
 - a. A live load of 40 pounds per square foot.
 - b. An operational wind load of 12.5 pounds per square foot or an approximate wind velocity of 70.0 mph.
 - c. A retracted and stowed wind load of 25 pounds per square foot or an approximate wind velocity of 100.0 mph.
 - d. A roof load (snow load) of 40 pounds per square foot.
 2. The structure shall be sufficiently rigid to avoid excessive sway when the Passenger Boarding Bridge is brought to a gradual stop
 3. All mechanisms for actuating, guiding and restraining the Passenger Loading Bridge and its components shall be designed so that no excessive noise, sway or sense of insecurity is apparent to passengers.
 4. No operating loads or vibrations shall be transmitted to the concourse building.
- B. Environmental Loads
1. The Bridge shall operate satisfactorily under ambient temperatures from –negative 25 degrees Fahrenheit to 125 degrees Fahrenheit with wind up to 60 mph. All of the Bridge components and materials shall either individually or collectively be designed or selected for long service life under such conditions.
 2. The Bridge assembly shall provide a clean, structurally sound, comfortable, and functional transition between the aircraft and the concourse building.
 3. The entire Bridge shall be weatherproof and any equipment or controls that are exposed to the weather shall be weatherproof type or housed in weatherproof boxes.
- C. Power Requirements
1. The PBB and WW shall operate on 480/277 V.A.C., 3 phase, 60 Hz. Wye configuration with neutral and separate ground (5 wire). The 480 V.A.C. shall be transformed to 120/240 VAC for lighting and controls.
 2. Power requirements for boarding bridges that are equipped with bridge mounted, 400 Hz solid state aircraft power units must have a dedicated input circuit of the 480V, 3 phase, 60 Hz "Y" configuration with neutral and ground power
- D. Operational Requirements
1. The cab shall be designed to rotate a total of 125 degrees (90-95 degrees CCW and 30 35 degrees CW). The cab shall rotate at a maximum peripheral speed of 19.0 feet per minute in either direction.
 2. The vertical lift speed as measured at the cab bumper shall be 2.5 fpm to 3.5 fpm
 3. The drive system shall permit the unit to be extended/retracted and rotated to any point within its operating envelope at a variable speed between 10 fpm and a maximum of 90 fpm
 4. The horizontal drive system shall include a decelerator device when approaching maximum extension, or when horizontal travel is stopped or reversed suddenly.

5. The rotunda permit the telescoping tunnels to swing through a minimum arc of 175 degrees (87-1/2 degrees CW and 87-1/2 degrees CCW of centerline). The rotunda floor shall remain level at all positions.
6. The telescoping tunnels shall be equipped with two stage limit switches, slow and stop, to control extended and retracted lengths. Mechanical stops with elastomeric bumpers to prevent overtravel in the event of limit switch failure shall be provided.

E. Interior Dimensions:

1. The Bridge shall have the following minimum interior clear dimensions:
 - a. Tunnel width: 77 inches.
 - b. Tunnel width with handrails: 70 inches
 - c. Tunnel height: 92 inches from finished floor level.
 - d. Telescopic tunnel width: 62 inches).
 - e. Telescopic tunnel width with handrails: 55 inches).
 - f. Telescopic tunnel height: 79.5 inches from finished floor level.
 - g. Minimum Tunnel Width: 4'-10"
 - h. Minimum Interior Height; 7'-0"
 - i. Minimum Transition Ramp Width: 4'-8"

F. External Supports

1. The Fixed Walkway Bridges shall be supported from beneath at the concourse building end by a column to support the inboard end and additional support columns located along the walkway to support the walkway.
2. Building Connection:
 - a. The Passenger Boarding Bridge System shall be designated as equipment and as such shall receive no structural support from the airport concourse building to which it is attached.
 - b. An aluminum diamond checker plate threshold shall be installed over the gap between the concourse building and the adjacent bridge interface. Interior metal and exterior flexible flashings shall provide a waterproof connection between the bridge and the concourse building.
 - c. At the concourse building, the bridge interface shall fit a door up to 48 inches wide by 84 inches high.

2.6 REQUIRED FEATURES:

A. Operating Console

1. Faceplate – Denver Special, 12'x12" touchscreen, with separate 5" LED camera screen
2. Joystick – 4 Quadrant (with Point & Go Capability) plus option in software to enable button steering
3. LED Work Light over console
4. Console heater

5. Eternal vent for control console for cool air ventilation
6. Interlocks
7. Warning devices.
8. Aircraft Cab Interim Illumination
9. Exterior Apron and Aircraft Interface Illumination.
10. Interior Illumination Controls.
 - a. Amber rotating light and a bell warning system on the exterior base of the bridge head/cab. These warning systems shall be automatically activated by any movement of the loading bridge, except when in the Autolevel mode.
11. A warning light shall be installed on the control panel to indicate when the steer limit switch is activated
12. Video display of wheel bogie taken from Rotunda looking toward cab. Screen shall be within console and not within control screen. Provide screen sunshields.
13. The control console shall be of such design and installation to be tamper and theft proof.
14. Control console shall have painted steel enclosure, heavy-duty oil tight push buttons, selection switches, and indicating lights. "Push to Test" push buttons shall be provided for indicating lamps. All legend plates shall colored graphic labels mounted on the surface.
15. A minimum of 6 spare conductors shall be included in the bridge control circuitry for possible future additions or changes to the control system.
16. Indicators
 - a. An aircraft cab floor height indicator mounted in the Control Console.
 - b. A drive/steer position indicator mounted in the Control Console that shows wheel orientation, regardless of the cabs rotational position.
 - c. An amber light (console) that indicates the auto leveling function is energized and operating.
 - d. A red light (console) that indicates an auto level travel timer has tripped. This light shall be coupled with an audible alarm. In the event of the interruption of primary power at the main contractor, both visual and audible warnings shall be activated when in the auto level mode.
 - e. An amber light (on the touch screen) that indicates when the bridge is approaching its maximum rotational points (Rotunda Limit). This light shall be coupled with an audible alarm.
 - f. A red light (on the touch screen) that indicates when the bridge has reached its maximum rotational points (Rotunda Limit), both left and right. This light shall be coupled with an audible alarm.
 - g. Amber light (on the touch screen) associated with control switch mounted in the operator control console indicating cab floor deicing "on" status.
 - h. A red light that indicates when the aircraft closure curtain is not in the full stowed position.
 - i. Green status light for pre conditioned air, including light and terminal points within the console for field connection to the light.
17. Controls:
 - a. A key switch with positions marked "Auto", "Manual", and "Autolevel". The

- key can be removed only in the "Auto" and "Autolevel" positions.
- b. A lever arm which controls all forward and reverse motions. The speed of travel (forward/reverse) shall be proportional to the movement of the lever arm. Lever arm will be programed to provide "Point-n-Go" steering
 - c. Emergency Stop Control: An emergency stop button shall be provided on the control panel to stop all motion of the passenger loading bridge.
 - d. Push button switches to extend or retract the Aircraft Canopy independently. Legend plates marked "Extend" and "Retract" and "Left" and "Right".
 - e. A red, mushroom head, maintained contact emergency stop switch for turning power off to all controls, except lights.
 - f. A push button switch to bypass the Rotunda travel limit switches, located inside of the console and to bypass the wheel rotation travel limit.
 - g. A push button switch to operate the cab rotation, left and right. Legend plates marked "Left" and "Right".
 - h. A touch switch will be provided in the software programming on the touch screen for floodlights that illuminate the apron area under the aircraft, drive column undercarriage. A switch for the overhead lights in the cab.
 - i. All switches and/or push buttons shall be labeled. Each function shall be spelled out, i.e. "Canopy" "Extend"-"Retract".
 - j. Primary Switch: A standard switch on the control panel shall be used to energize and de-energize the other panel controls.
 - k. A disconnect switch inside the bridge main control power cabinet shall be provided. When this disconnect switch is depressed, all power to the bridge shall be interrupted.
 - l. Labeling: The control panel shall include all passenger loading bridge motion controls, cab weather door controls, canopy controls, emergency stop control, cab and control panel lights, ramp flood lights, and associated indicator lights, meters and gages, if any. These shall be permanently labeled as to function.

B. Operational Features

1. 125 Degree Cab Rotation, adjustable limit switches and fixed stops – Right Service Access
2. Beckoff Control System – Twin CAT Control (Software)
3. full width non-abrasive aircraft spacer and Spacer Sensor
4. Aircraft bumper to be furnished with B737 left doorjamb reference strip. Stripe to be located approximately 71 inches (1800 mm) from right end of bumper.
5. An electrical interlock shall be provided preventing forward motion and cab rotation with the Aircraft Closure extended. The interlock shall not prevent the bridge from being withdrawn from the aircraft with the canopy extended.
6. Passenger loading bridge motion control or limit devices mounted on the bumper shall be located at the extreme outboard ends of the bumper and along its centerline or shall be mounted continuously along the face of the bumper.
7. Provide for clearance for B737 pitot tubes on all bridges. The vertical front-edge of the bracket shall be no closer to the front vertical edge than three (3) inches.
8. Movement Prevention Interlocks:
 - a. General: The control system logic shall be such as to preclude damage to circuits or mechanical systems because of simultaneous contrary control

signals or an otherwise unsafe combination of control signals.

- b. Deployed Canopy Interlock: All passenger loading bridge motion, except auto leveling, shall be possible only when the canopy is in a fully retracted position. Provide for a mechanical override (of the dead man type) to permit the retraction (only in case of mechanical emergency or mechanical failure) of the bridge with the canopy not in the fully retracted position.
- c. Contrary Control Signal Interlock: All loading bridge motion shall be precluded whenever contrary control signals (e.g., extend and retract) are activated.

9. Actuator Systems:

- a. General: All actuator systems shall be protected from motion overrun near the design limits of motion. All equipment shall be designed to be fail safe both in terms of the components themselves and in terms of the passenger loading bridge as a whole.
- b. Limit Switches for Electrical Mechanical Designs: Electrical limit switches shall be provided on all passenger loading bridge movement actuator systems, car bumper, canopy system, and include fail safe limit switches near the end of horizontal travel and vertical travel. These switches, when contacted, shall de-energize their respective actuator systems. The tunnel rotation limit switch shall be located per manufacturer's recommendations and reset locally.

10. Auto leveling:

- a. All passenger loading bridges shall be equipped with an automatic leveling device which permits the bridge to automatically respond to small changes in aircraft door sill height thus maintaining a constant relationship between the floor of the aircraft and the floor of the loading bridge.
- b. It shall not exert any stresses on the loading bridge. The leveling device actuating mechanism or sensor which contacts the aircraft shall be located on the right side of the cab in full view of the operator at all times.
- c. If the actuating mechanism or sensor is located in the cab interior or other area normally exposed to passenger traffic, it shall be adequately protected or shrouded to preclude passenger interference.
- d. It shall function reliably on all specified aircraft regardless of door location, fuselage contour, and aircraft doorsill height.
- e. Since the aircraft and passenger loading bridge are exposed to various wind conditions and jet blast during the servicing period, the auto level actuating mechanism and sensor shall be capable of activating within the full range of its horizontal or lateral clearance.
- f. The control circuitry shall include an adjustable solid-state timer that will limit the automatic leveler's continuous response in either direction.
- g. The timer shall have a maximum rotation of one revolution and allow a range of adjustment of at least six inches (150 mm) up or down from a neutral position.
- h. The circuitry shall include an audible alarm and warning light at the control station, and a bell or horn in the general ramp area, which shall produce a distinctively different sound than any other on the unit, when the timer

interrupts the response to the system.

- i. When the timer circuit is interrupted, the vertical lift system shall automatically be locked in position and de-energized, a vertical travel brake automatically engaged and a red warning light and audible alarm will be energized on the control panel, a red warning light and an audible warning horn will be activated in the ramp area, and an audible alarm sounded in the adjacent hold room.

11. Adjustable Cab Floor

- a. The cab (aircraft vestibule) shall be provided with a synchronized up and down control to assure a level horizontal attitude at the various extension lengths, vertical heights, and tunnel and cab rotations of the passenger loading bridge. The Contractor shall submit details of his design for review by the Construction Supervisor.
- b. Aircraft Height Indicator: An aircraft height indicator to enable the operator to pre-position the cab to the approximate aircraft sill height prior to the arrival shall be prominently displayed on the control console. This indicator can either be digital or have lights which shall indicate the sill height of each aircraft type.
- c. The indicator shall be permanently calibrated for each aircraft prior to the initial inspection of the passenger loading bridges.
- d. All electrical connections to the height indicator stops shall be securely fastened and enclosed in a box for waterproofing and to prevent tampering.
- e. The lifting mechanism shall hold securely at any elevation within the travel range with or without power supplied and also in the event of a power failure.

12. 737 Cut-out
13. Slowdown Infrared Sensor
14. Push Button Vertical Drive
15. PC Air Interlock
16. 400Hz Cablehoist & Interlock
17. Canopy Forward Drive Interlock

C. Control Cab Interior

1. The operator's position in the control cab shall be forward facing and designed to permit the operator to position the loading bridge with the cab weather door closed. Suitable enclosures, guard rails, etc., shall be provided to protect the operator from being pitched out the open end of the cab (when operated from an open door) in case of sudden stops or inadvertent movements of the bridge. A handhold shall be attached to the wall on both sides of the cab weather door.
2. Cab slat view panel every other slat
3. Manual lockable roll-up door with vision panels, minimum width 3'-8"
4. Heated (deicing) aluminum cab flooring
5. Aluminum Bubble Floor.
6. Cab Hood Canopy Cover
7. Cab Windows
8. Single Latch Cabinet
9. Cab Subfloor – Aluminum bubble

10. Service Door – 2'-6" wide by 6'-8" tall
11. Kickplate – Stainless Steel inside service door
12. Provide positive identification, visible to the operator for both the front and back sides of the bogey. The wheel's position shall also be identified by a wheel position indicator on the control panel.

D. Exterior

1. LED Lighted Gate Sign
2. Aircraft Closure Canopy – Grey Pressure sensitive limit switches or tension switches shall be incorporated into each side of the closure mechanism to prevent excessive pressure on the aircraft.
3. Galvanized Curtains with Vision Panels in Cab
4. 18 inch (457 mm) circular convex mirrors, one on each side
5. Pantograph System – Twin 4" aluminum tubes with solid aluminum block clamps mounted on each side of the bridge, four tubes total. All power, communication and glycol hoses will be routed through the Pantograph System. No cable carrier systems will be allowed. Power and Communication cables shall not share an aluminum tube with glycol.
6. Roller Mounted Ice Scraper
7. Flashing between the building, WW, Rotunda, and PBB shall be provided to form a weather tight connection between all elements.
8. Dual Flap type seals shall be provided between the rotunda and the hinged telescoping tunnels.
9. Rotunda side curtain shall be galvanized steel unless otherwise noted.
10. Concourse Door Thresholds shall bridge the interface between the building and PBB, rotunda or WW and have an anti-slip surface. Cushion pad(s) shall be provided at the point of contact between the canopy and aircraft fuselage to prevent denting and or scratching of the aircraft skin or cabin and cockpit windows. Pressure exerted by the closure against the aircraft fuselage shall not exceed 2 psig (13.8 kPa).

E. Roof Access

1. Roof Handrail – Galvanized, installed on "C" tunnel only
2. Roof Access Ladder w/ safety cage
3. Roof Maintenance Cable – extendable/retractable, rated for two workers to be able to use simultaneously.
4. A roof access ladder shall be provided on the service landing. The frame of the ladder shall be of galvanized steel channel and the rungs shall be galvanized steel bars with cast abrasive.
5. A system to allow workers on the bridge roof to attach safety harnesses shall be provided.
6. A handrail on the roof to protect workers maintaining the vertical lift motors.
7. Structural Performance of Handrails and Railing Systems: Design, engineer, fabricate, and install handrails and railing systems to comply with requirements of ASTM E 985 for structural performance
8. Top Rail of Guardrail/Handrail Systems: Capable of withstanding the following loads applied as indicated: Concentrated load of 300 pounds applied at any point non-concurrently, vertically downward, or horizontally.

9. Handrails Not Serving as Top Rails: Capable of withstanding the following loads applied as indicated: Concentrated load of 200 pounds applied at any point non-concurrently, vertically downward or horizontally.
10. Infill Area of Guardrail Systems: Capable of withstanding a horizontal concentrated load of 200 pounds applied to one square foot at any point in the system, including panels, intermediate rails balusters or other elements composing the infill area.

F. Pre-conditioned Air Unit (PCA)

1. Bridge mounted in accordance with Division 23 sections.
2. Stand mounted in accordance with Division 23 sections.

G. Service Assembly

1. A service door served by a stair and landing, shall provide apron access to and from the bridge for authorized personnel. The service door shall be located on the right side of the cab.
2. The service door shall be hollow core, steel door heavy 1 hour fire rating and an automatic door closure. It shall be of a standard size with nominal dimensions of 2 feet 6 inches by 6 feet 8 inches
3. It shall be equipped with a 1/2 inch wire mesh glass upper window a minimum size of 12" x 18"
4. Service Door Lockset – Trilogy Alarm Lock DL3500 Trilogy High Security Mortise Digital Keypad Lock w/ Audit Trail
5. A 30 inch high stainless steel kickplate shall be provided for the full width of the inside of the door.
6. A door stop and hook assembly shall be provided on the stair handrail or platform to prevent damage to the lockset and/or door.
7. The service stair shall be equipped with self-adjusting risers with open mesh galvanized steel treads (grip strut) and is supported at the apron on castering rollers.
8. The caster type rollers shall have solid rubber tires that are designed to operate on asphalt pavement in elevated temperature conditions.
9. All steps shall have an equal rise with a tread width of 27 1/2 inches and a depth of 9 1/2 inches
10. Both sides of the stair shall be equipped with tubular steel handrails of proper height to comply with applicable codes and regulations.
11. Clear width between handrails shall be a minimum of 28 inches
12. The service stair shall be fully usable at all heights and positions.
13. The door shall be so constructed that the door and all its components can be easily removed and reset or replaced f
14. Expanded Metal Landing Deck – Outside of service door to stairs
15. Exterior Stair Assembly – galvanized deck span or aluminum
16. Service Platform Light – 100W LED Flood Light
17. Exterior Stair Handrail – galvanized or aluminum

H. Drive System

1. Apron drive units are those that have "major" degrees of motion, lateral, horizontal and vertical, of a portion of the loading bridge tunnel and the bridge head/cab

- about a fixed point.
2. The apron drive units shall be capable of having simultaneous omnidirectional (extension, lateral and horizontal) movements in a fashion similar to a motor vehicle. These invariably include vertical elevation and significant rotation in a horizontal plane and include extension retraction capability. The Contractor shall provide a manual override to release wheel bogey brakes to permit towing the passenger loading bridge into or out of position on the apron in case of power failure.
 3. The override system shall be mechanically interlocked to preclude normal operation with the brakes locked out.
 4. The wheel bogey shall include tow lugs on the front and rear to permit attachment of a suitable tow bar.
 5. All apron drive units will be equipped with "Point-n-Go" steering.
 6. Trelborg Solid Rubber Drive Tires, Cast Rim Type, no substitution.
 7. The tire rim, wheel and hub design shall be such that only the wheel to axle hub bolts/nuts are available for removal while the wheel is mounted on the bogey.
 8. Extra Low Range Drive Column
 9. Actuator Cover (Right Side)
 10. Actuator Cover (Left Side)
 11. Pre-Positioning
 12. Vertical Drive - Electro Mechanical:
 - a. The bridge shall be moved vertically by means of two recirculating ball bearing screw assemblies. Each assembly shall be independent of the other, with individual motors. The ball nut of this assembly shall be equipped with wiper brushes and a self-locking acme type thread that will prevent unit collapse in the vent of ball nut failure.
 - b. The vertical drive motors shall be fitted with spring-applied brakes that release only when electric power is applied and vertical motion, up or down, is signaled from the operator's console or the auto level system.
 - c. The brakes shall hold securely at all elevations, without creeping whether the bridge is in operation or not.
 - d. The fault detector circuit shall shut down the electrical power to the vertical drive motors and sets the brakes independently of the operator. This shall occur if the bridge is in the vertical operate mode and there is differential motion at the ball screws.
 - e. Attached into the ball screw's lower end shall be a tapered collar which prevents the screw from disengaging the ball nut. Vertical rate of travel shall be a constant speed.
 - f. Reference stripes shall be painted or mechanically fastened on the inner tube (s) to indicate maximum travel of column, both up and down.
 - g. Back up emergency magnetic type limit switch(s) shall be provided in the vertical circuit, for both up and down limits.
 - h. Each screw shall be capable of supporting a full loaded bridge.
 - i. Inspection holes in each column tube shall be provided to allow baroscope inspection of the ball screw surface. All holes shall be aligned in inner and outer column tubes. Covered plates shall be provided in outer tube.
 13. Horizontal Drive:

- a. An electro mechanical drive system shall provide extend, retract, swing and steer capabilities at variable speeds up to 90 ft. per minute. This two-wheeled system shall operate on solid tires. Both wheels shall be independently driven by DC gear motors with solid-state SCR controls.
- b. The entire system shall be contained within the bridge and require only AC power.
- c. A dynamic braking system shall allow the bridge to come to smooth, controlled stops. Spring actuated brakes shall be located on each drive motor and lock the bridge in place whenever electrical power is cut off by moving the control lever to the neutral position or if power fails. The horizontal drive motors shall be equipped with brake releases.
- d. Connection lugs shall be provided to allow the bridges to be towed in the event of power failures.
- e. The control logic shall be such that if any one (1) horizontal or vertical drive motor is shut-down by current overload, all drive motors shall be shut down, necessitating a re-start from the operator's control panel.

I. Communications

1. Wi-Fi Capable, Wireless MOXA AMK 3121 w/antennae on sign or cab
2. Ethernet switch
3. Remote Auto Level Alarm
4. Surveillance Camera (CCTV) – Rotunda mounted
5. Telephone Service: A 6-wire telephone outlet, complete with all conduit and fittings for installation of telephone or intercommunication system and a standard modular jack, shall be provided near the Control Station. The telephone set will be provided by DIA.
6. Provide and install a 3/4 inch (min.) diameter galvanized steel conduit, with 8 conductor communications cable from a junction box at the rotunda to a junction box installed in the cab, 54 inches above the floor at the console for future communications
7. Provide and Install Level Alarm at Concourse Door

J. Electrical

1. All electrical systems shall be guarded and protected from damage that might be caused by falling objects or collision with aircraft service equipment and other moving ground vehicles.
2. Electrical control panels, disconnect switches shall be so located that they are at all times accessible to the maintenance personnel standing at ground level without the use of a ladder,
3. LED Lighting in all locations
4. Column Disconnect – 60A 480V with Circuit Breaker for PBB, GPU & PCA
5. Identify GPU and PCA requirements
6. 90KVA/140KVA POU GPU
7. Rotunda Lighting – LED 120V fixtures
8. Emergency lighting – 5 each with UPS battery back-up. All fixtures to be LED
9. Exterior Lighting: Exterior lights shall have aluminum housing, weatherproof (gasketed) with high impact lens.
10. LED fixtures shall be standard type suitable for use with Passenger Boarding

Bridge installations 2'x2' and 2'x4' LGLED Series

11. Interior lighting shall be actuated by a motion switch located next to the concourse door. Lighting calculations shall be submitted under provisions of Article titled "Submittals".
12. LED Equivalent of PAR38 Floodlight assembly – 100W, 3 each LED Fixture
13. Power receptacles - Minimum of 3, (Cab, Tunnel, Lwr Dr), 120V 20 amp receptacles w/ GFI
14. The service stairs and landing shall be illuminated by a 100-watt weatherproof LED fixture with a control switch inside and adjacent to the service door.
15. sealed beam type floodlights shall be provided to illuminate the apron area ahead of the bridge. A sealed LED fixture shall be provided just beyond the roll up weather door to illuminate the cab aircraft interface area.
16. Anti-Chafing Devices: Whenever electrical cables are required to slide or move, anti-chafing devices shall be provided. Acceptable anti chafing devices include grommets, flexible sleeves and jackets, and other approved similar protection.
17. 30/50/60 ton POU PCA or AHU Size
18. Electrical panels mounted on the rotunda at apron-level shall be equipped with a locking mechanism containing a Best cylinder

K. Finishes

1. Ceiling Panels – White
2. Walls
 - a. Interior wall treatment shall consist (unless noted otherwise) laminated flame resistant phenolic plastic panels (Wilson Art or equivalent) four (4) feet wide with aluminum trim and recessed black accept strips. The decorative facing shall consist of a high-pressure laminate.
 - b. The backing shall be a non-decorative laminate equal to Wilson Art # 264, approximate thickness 0.030”.
 - c. The finished product shall carry a UL label and meet the flame spread test as listed in ASTM E-84.
3. Floor
 - a. Passenger Boarding Bridge floor finish shall be factory-installed carpet. All carpeted area must have metal edges on all sides (carpet clamp down metal with teeth).
 - b. Cab floor finish shall be black ribbed, non-skid, neoprene floor finish installed with Musson Rubber Company Epoxy Glue, #775, or approved equal.
 - c. Anodized aluminum and other galvanized, aluminum, or stainless steel shall have a satin finish.
4. Carpet moldings – Aluminum
5. PLB and WW to be fully insulated with R4.5 minimum
6. Side Panels
7. Tunnel Hand Rail – Aluminum, both sides, all sections and at ramps
8. Tunnel Subfloor – Marine grade fire resistant plywood
9. Interior wall finish – High Impact Phenolic Resign Wallboard, color to be selected by owner from standard finishes

10. Two Tone Paint with Epoxy Primer
11. One coat of Sherwin-Williams High Build "Chromate Free" Epoxy Primer E65AC8\E65RC5 (or equivalent) shall be applied. The dry film thickness shall be 2-10 mils
12. Sherwin-Williams high solids Polane H Poly- urethane (or equivalent) shall be applied. The dry film thickness shall be 2-3 mils. The color shall match the wallboard color unless otherwise specified.
13. Maintenance Cover Plates
14. Transition Ramps between tunnel sections shall have yellow chamfered edges and black ribbed rubber matting.

L. Electronically Operated 400 Hz Cable Hoist

1. The existing hoist system consisting of either one or two cable hoists (for dual output 400 Hz converters) shall be carefully removed from existing bridge, temporarily stored and maintained in good condition and re-installed on the new bridge

2.7 SOURCE QUALITY CONTROLS

- A. Manufacturer shall supply a report of any Non-Conforming Work during the manufacturing process

PART 3 - EXECUTION

3.1 EXAMINATION

- A. Before installation verify all critical dimensions, and examine supporting structures and all other conditions to which work is to be installed.
- B. Installation constitutes acceptance of existing conditions and responsibility for satisfactory performance.

3.2 INSTALLATION

- A. Work shall be performed by competent installation personnel in accordance with manufacturer's installation instructions and approved shop drawings.
- B. Comply with the National Electrical Code for electrical work required during installation.
- C. Coordinate elevator work with the work of other trades, for proper time and sequence to avoid construction delays. Use benchmarks, lines, and levels designated by the Contractor, to ensure dimensional coordination of the work.
- D. Lubricate operating parts of system where recommended by manufacturer

3.3 RE-INSTALLATION

- A. Reattach glycol lines. Fill with up to 20 gallons of 50% ethylene per bridge.
- B. Contractor shall also coordinate reconnection of existing Pre Conditioned Air monitoring system with DIA HVAC department. Removal and reinstallation of existing Pre Conditioned Air units shall be done in such a way so that only the unit being removed and reinstalled shall not be connected and recognized by the monitoring system. Prior to removal, DIA and Contractor shall inspect and document condition of existing equipment.
- C. DIA Project Manager / Sr. Inspector and Contractor shall also coordinate reconnection and start-up of existing Ground Power Unit with DIA Hi-Tech department. Removal and reinstallation of existing GPU's shall be done in such a way so that only the unit being removed and reinstalled shall be connected and recognized by the monitoring system if applicable.
- D. Contractor shall also coordinate re-connection of communications with DIA Systems for direct line and Wi-Fi.

3.4 FIELD QUALITY CONTROL

- A. Acceptance testing:
 - 1. Upon completion of the installation and before permitting use of PBB and WW, perform acceptance tests and permitting as required by CCD. Perform other tests, if any, as required by governing regulations or agencies.
- B. Commissioning, Manufacturer's Field Service's
 - 1. Advice Project Manager and AHU of dates and times tests are to be performed.
 - 2. PBB and WW shall be commissioned by manufacturer's representative before PBB is put into service.

3.5 ADJUSTING

- A. Make necessary adjustments of operating devices and equipment to ensure that all systems operate smoothly and accurately.

3.6 CLEANING

- A. Before final acceptance, remove protection from finished surfaces, and clean and polish surfaces in accordance with manufacturer's recommendations for type of material and finish provided. Stainless stall shall be cleaned with soap and water and dried with a non-abrasive surface; it shall not be cleaned with bleached-based cleansers.

3.7 PROTECTION

- A. At time of Substantial Completion of work, or portion thereof, provide suitable protective coverings, barriers, devices, signs, or other such methods or procedures to protect work from damage, unwanted entry and deterioration. Maintain protective measures throughout remainder of construction period.

3.8 TRAINING

- A. Manufacturer's Rep will also be responsible for providing 16 hours, over two days of on-site training for DIA personnel, airline user personnel, and any other parties with a need for operational training as designated by DIA.

3.9 FINAL ACCEPTANCE INSPECTION::

- A. Final acceptance shall be done on an individual PBB/Gate basis.
- B. After full compliance by the Contractor of all outstanding Punch List items, DIA shall perform the final inspection of the bridge.
- C. The Contractor shall make certain that each bridge is complete in all respects and operating properly, all deficiencies noted in the Conditional Acceptance Inspection are corrected, and all training accomplished prior to the requesting the DIA Project Manager to witness and make the Final Acceptance Inspection. Upon satisfactory completion of that inspection, a Certificate of Customer Acceptance will be issued. The warranty for each individual bridge shall begin upon its Final Acceptance.
- D. DIA reserves the right to employ an independent testing laboratory to inspect the bridges to verify the Contractor's compliance with the specified structural, welding, mechanical, electrical, and fireproofing requirements. Deficiencies and / or violations reported by DIA's laboratory shall be immediately corrected by the Contractor at no cost to DIA. The cost of re-inspection by DIA's Laboratory shall be borne by the Contractor and DIA will deduct such inspection costs from monies due to the Contractor.



Method Statement Passenger Boarding Bridges Denver International Airport

Provision and Installation Passenger Boarding Bridges

The following is a general method statement for works associated with the replacement of passenger boarding bridges (PBB) at the Denver International Airport (DIA). This document is intended to describe the methods employed by JBT AeroTech – Jetway Systems (Jetway) to prosecute the scope of work described in the Request For Proposal.

Overview of the Scope of Work

This RFP is for the take down, removal and scrapping of six (6) existing passenger boarding bridges (PBB) at Gate A31, A49, B46, C33, C34 and C36 and the installation of six new PBB with similar operating ranges as the existing PBB. Included in the work is the removal of existing ancillary equipment such as ground power and preconditioned air and the reinstallation of this equipment on the new PBB's. New pantographs for glycol- carrying hose will be supplied for the A and C gates in lieu of the existing Service Transport Units or existing glycol pantographs.

The existing equipment will be taken to a storage yard as indicated in the RFP, where the DIA personnel will have the opportunity to salvage parts for use on other existing PBB's at DIA. After the DIA Maintenance staff has released the bridges, they will be taken to IMI Metals for scrapping and recycling.

Scheduling and Coordination

Upon receipt of a Notice to Proceed, Jetway will assign a full-time Project Manager who will be responsible for finalizing all schedules and communicating with the DIA team. The overall schedule, project milestones, and completion dates will be developed jointly between Jetway's Project Manager and the DIA Project Representative. The Jetway project manager will have full authority to act on behalf of Jetway on project related issues.

Project Schedule

Jetway has based the planned schedule on information provided in the Request For Proposal, our production capacity and consultation with our installer.



The schedule reflects our commitment based on the award date no later than July 10, 2015. Should the NTP be issued after July 10, 2015 the schedule may slip proportional to the delay. Jetway will make every attempt to get as many PBB's installed prior December 31, 2015 as possible; however, there are constraints with the major holidays that will make this a challenge.

Project Team

JBT will be the prime contractor for the work. Western Industrial Contractors will be the installer of the equipment and they will utilize Intermountain Electric for the electrical portion of the work.

Project Management

Given the quick turnaround required for this project our project managers must be proactive. On receipt of the NTP the Project Manager will make initial submittals. The Jetway team is in a unique position to expedite the submittals given the understanding of the product and processes at DIA.

The Project Manager will be responsible to review the specifications and equipment configuration with the Owner to ensure that both parties fully understand the intent of the specifications, and all agree to the final equipment configuration. The Jetway Project Manager will prepare an in-house job order that communicates the equipment and project needs to each of the various departments working within Jetway

The Project Manager will also be responsible for issuance of the subcontracts and be the primary point of contact for issues related to certified pay roll and M/WBE.

Engineering and Manufacturing

At notice to proceed, Jetway's manufacturing organization schedules common made parts, materials and long-lead time items from a planning bill of materials. Once our engineering department has completed the engineering drawings and the MRP order entry, the computerized MRP creates demand for procurement and building of project-specific parts. The manufacturing completion dates drive demand for each unit to meet the project milestone ship dates. MRP schedules each phase of manufacturing and identifies critical progress milestones. Critical Path methods are used throughout the manufacturing process to ensure no delays in manufacturing.

As the PBB's complete manufacturing and testing, they will be stored in a staging area until the designated shipping time. At that time gate specific equipment will be shipped to the project site for installation.

Factory Testing

Jetway tests the major components of the PBB at the manufacturing facility to make certain all parts and electrical circuitry are fully functional. This procedure reduces the installation troubleshooting time and identifies faulty parts prior to shipment. Quality control documents developed by the Jetway Quality Assurance team ensure the manufactured equipment and its operation conforms to the contract. Should any deviation occur the customer will be notified by the Jetway Project Manager.

Freight

Site requirements determine the manufacturing sequence and freight orders. Jetway Project Management will schedule the loads to arrive in accordance with the installation timelines.

The freight will be arranged for transport from the manufacturing facility to DIA using two tractor-trailers for each PBB assembly. One stretch, double-drop, two-axle trailer will be used to transport the main tunnel section and cab. Another 48-foot long single drop (step deck), two-axle trailer will haul the rotunda, rotunda support column, drive column, service stair, landing deck and all the installation hardware

Installation

It is our understanding that Jetway will have free and clear access to the gate during the agreed upon time and once the installation has begun we will have access to the gate until completion. It is our intent to work during normal daylight working hours, Monday through Friday. Our schedule reflects a single gate closure for the duration of the work. One gate will be completed and returned to operation prior to taking the next gate out of service.

An 80-100 ton crane will be used to remove and erect the bridges. It is our understanding that there is a sub-basement in the area of the A Concourse gates that will require special set up of the crane. Other equipment such as fork lifts and man lifts will be utilized.

The crew size will vary on the day and task but average between 5-7 workers. The trades will be Millwrights and Electricians.

The installation sequence has been proven through many installations of this nature at DIA. The sequence will take 8-10 working days and every effort will be made to shorten this duration if possible; however this time period also allows for unforeseen circumstances such as weather delays and the like.

- Day 1 will be utilized in the preparation of the bridge for take down. Ancillary equipment will be removed. The electrical service will be tagged out using proper DIA protocol. The terminal door will be secured to ensure passenger and DIA personnel safety. In the case of Gates A39 and A47, the existing walkways will be shored and supported in preparation of the removal of the supporting PBB.
- Day 2 will be the final preparation and the removal of the bridge from the gate area to storage.
- Day 3 will be the arrival and erection of the new passenger boarding bridge. The bridge will not be electrically connected at this point.
- Days 4-8 will be spent in the following tasks
 - Flashing -- exterior and interior flashing of the rotunda
 - Grouting of the support column
 - Reattachment of the ancillary equipment, GPU, PCA and Bag Slide
 - Reconfiguration of the electrical service at the rotunda
 - Touch up painting
 - Cleaning of the interior of the PBB
 - Power Washing the exterior of the PBB
- Day 9 will be spent with the Jetway field engineer setting the limits of the PBB and ensuring all systems are functioning properly. A preliminary punch list will be developed between Jetway and Western Industrial
- Day 10 is the inspection and acceptance of the bridge with the Jetway field personnel and development of the final punch list. The PBB will be available for service following the acceptance.

On-Site Testing and Commissioning

The Jetway Field Engineer along with a representative of the installation sub-contractor, and the DIA project representative will conduct an inspection of the PBB. Checklists for the PBB are furnished prior to the testing and commissioning period. Jetway Project Manager, in coordination with the customer, will develop the actual commissioning checklists of all equipment prior to starting the installation portion of the project.

Each PBB will be cycled through its full horizontal, vertical, and steering functions as well as cab rotation travel limits to ensure the equipment is performing to the requirements of the specification. Any changes needed to make the equipment compliant with the project specifications, will be completed before final acceptance.

Operator and Maintenance Training

The RFP calls for 16 hours of operator training. We will divide the hours as determined by DIA to support the tenant airlines and user group. The RFP did not call for maintenance training. JBT does offer maintenance training and even a video tape of



the training session for orientation and refresher training. This can be quoted separately if desired.

Operator training consists of high-level orientation and introduction to the functions of the PBB. Specific operational criteria and procedures will be left to DIA and the specific airline users.

Warranty

The warranty called for in the RFP is a one year parts and labor warranty. JBT will work with DIA to determine the best procedure for providing the highest quality of service. JBT is amenable to using DIA maintenance personnel for the warranty work. A procedure will be developed with DIA for authorization and charging of warranty work. Further JBT and DIA will establish reimbursable rates.

Should DIA elect not to participate in the warranty work, JBT will contract with Western Industrial Contractors to be the first responder to critical warranty issues. This will allow a response time of four (4) hours or less. JBT will then have the option of having Western Industrial complete the work or send in a JBT Field Engineer.



1. Describe, in detail, the process of installation for the Passenger Loading Bridges (PLBs) proposed. Please break out all phases of the work and anticipated time to complete each phase. Include all proposed subcontractors that may be used in the installation. Identify any and expectations you may have of DEN and its employees regarding this process.

Gate	Proposed PBB Model	GPU Cable	PCA Cable	Glycol Pantograph	PBB Electrical Pantograph
A31	A3 64/131	90 KVA POU	60 Ton AHU	Yes	Yes
A49	A3 64/131	120 KVA POU	60 Ton AHU	Yes	Yes
B46	A3 60/119	90 KVA POU	45 Ton POU	NR	Yes
C33	A3 58/110	90 KVA POU	60 Ton AHU	Yes	Yes
C34	A3 58/110	90 KVA POU	60 Ton AHU	Yes	Yes
C36	A3 60/119	90 KVA POU	60 Ton AHU	Yes	Yes

General Description of PBB Configuration

- ETL Certification
- NFPA – 415 Fire Code
- Smooth and Crowned Roof
- 125° Cab Rotation / Right Service Access - (Flat - A3 64/131)
- Beckhoff PC Controls – per DIA Standard
- Stainless Steel Column Disconnect – Circuit Breakers for PBB/400 Hz/PCA Per DIA Standard
- Electro-Mechanical Vertical Lift Columns with extra low range capabilities, per DIA Standard
- Solid Tires, Trelleborg per DIA Standard
- LED Light Fixtures, full fixtures not bulb replacement, all lights tunnel, flood lights, landing, Gate Sign per DIA requirement
- Automatic Leveling Cab Floor
- Aircraft Spacer with w/ 737 cut-out
- Actr Brkr Trip Reset
- Actuator Cover - (Right and Left Side)
- Aluminum - Ramp Handrails
- Aluminum Bubble Floor
- Aluminum Tunnel Handrail - Both Sides



General Description of PBB Configuration

- Auto Level Failure Alarm Beacon
- Cab & Landing Mirrors - Galvanized
- Cab floor de-icer
- Cab Hood Canopy Cover
- Cab Rotate - Interlock - (AD)
- 400 Hz - Interlock
- Canopy Forward Drive - Interlock
- PC Air - Interlock
- Carpet
- Carpet Moulding
- Drive Column Reflective Tape, Upper Drive
- Elapse Time Meter
- Emergency Lights as per NFPA 415
- Primer and Paint System
- Fire-resistant Marine Grade Plywood, tunnels
- Full Insulation
- Galvanized Cab Curtains with Vision Panels
- Galvanized Stair Handrail
- Gate Sign w/Special Denver Mtg Bracket
- Two Piece Aircraft Closure
- Console Heater w/Thermostat Upper and Lower Console
- Horn Claxon Warn
- Joystick – 4 Position
- Kick plate Cab Door, Stainless Steel, both sides
- Kick plate Service Door, Stainless Steel, inside only
- Roof Ladder and Cage, Galvanized
- Maintenance Cover Plates with Hinge
- Console Faceplate, Denver Style with 12" HMI
- Operator Stop Button - Mushroom
- Receptacles (Cab,Corr,LwrDr) - 20 Amp GFI - Stainless Steel Covers
- Rib Rubber - Cab/Bubble
- Ribbed Rubber - Ramp
- Remote Auto Level Alarm
- Roof Handrail- Galvanized
- Roof Maintenance Safety Cable
- Safety Chain - (Cab Safety Barrier)
- Service Door Lockset - Trilogy Alarm Lock DL3500, per DIA Standard
- Slowdown Infrared Sensor
- Spacer Limit
- Stair Assembly w/ Deck Span tread
- Wallboard

General Description of PBB Configuration

- Camera (CCTV) - Rotunda Mounted w/ PCA Extension
- Double Swinging Doors with half glass
- Telephone Jack in Cab
- Tunnel Mounted Ice Scraper
- Two Tone - (Paint Scheme)
- Elapsed Time Meter - Vertical Drive
- Ceiling Panel – White Plank
- Wind Flaps - Cab & Rotunda Curtains
- Deckspan - Landing Deck - 125°
- Work Light - (Console) ✕ LED ✕
- Stewardess Handle - Both sides ✕
- WiFi Provisions w/Antenna
- Ethernet Switch
- UPS - P/N 4070389 ✕
- Additional Engineering Safety Features ✕
- Pre-positioning
- Strobe Flashing Beacon
- Warning Light on Console Panel - Steer Limit Switch ✕
- Push Test Button
- Keyswitch "Auto" "Manual" "Autolevel" ✕
- Canopy Push Button ✕
- Power On Button ✕
- Additional Spacer Limit ✕
- Enclose Height Sensor
- Interior Lighting Motion Sensor Switch Next to Concourse Door ✕
- Anti-Chafing Device on Cables ✕
- Rotunda Elec Panels w/locking mechanism Best Cylinder ✕
- All cables in doglegs in lieu of underbridge festoon

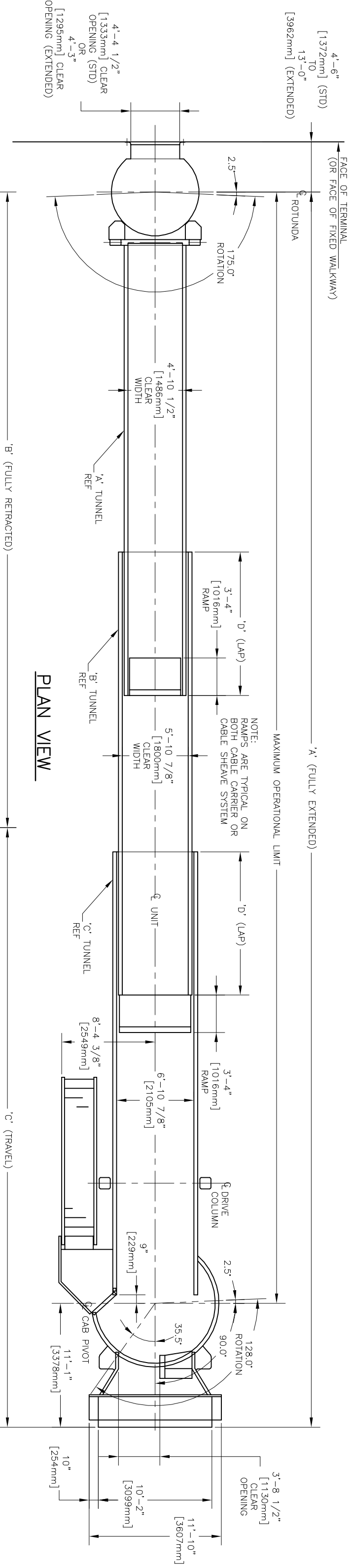

PLAN VIEW

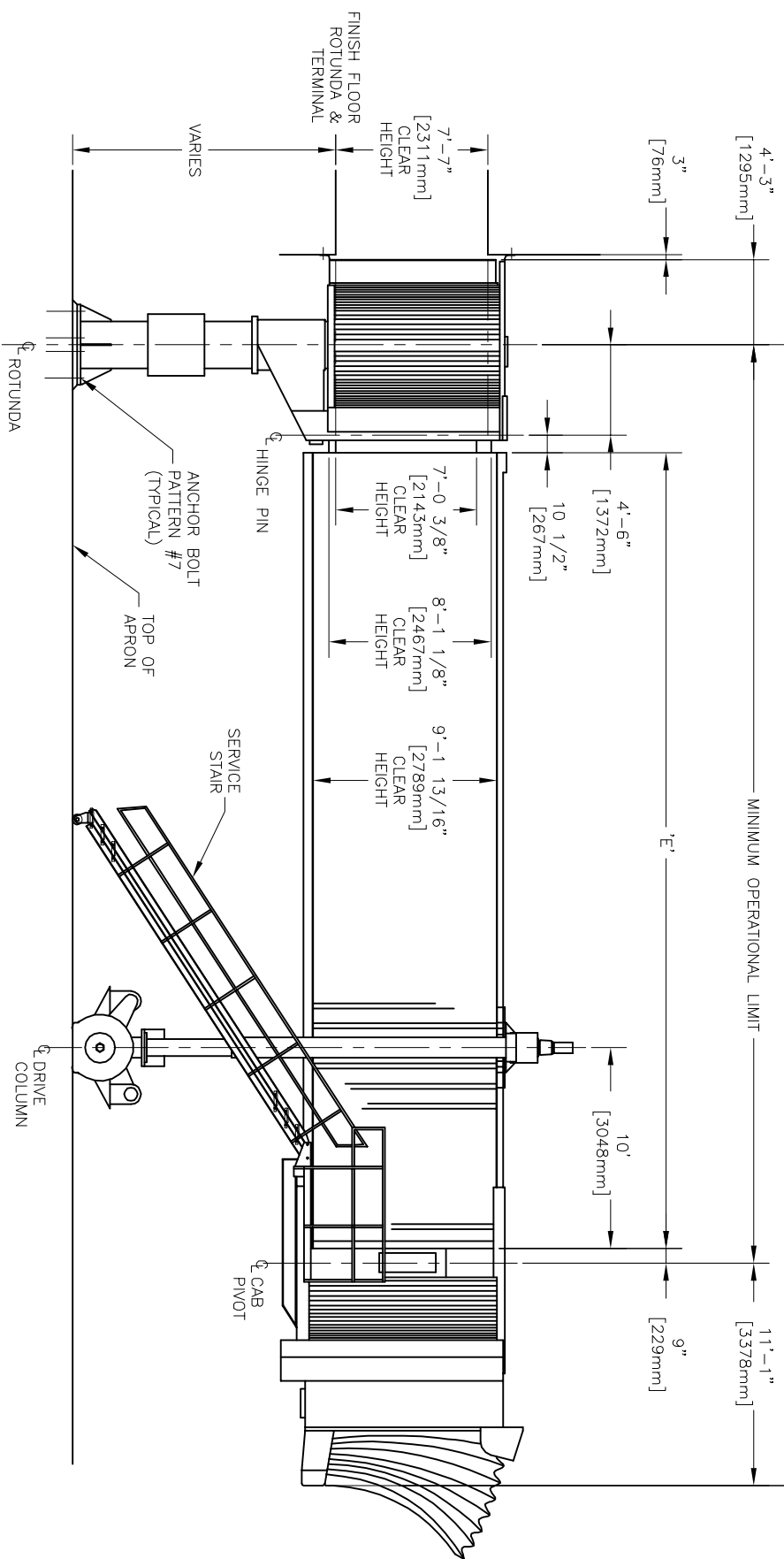

RIGHT SIDE ELEVATION

UNIT MODEL	OPERATIONAL LIMITS		DIM 'A'	DIM 'B'	DIM 'C'	DIM 'D'	DIM 'E'
	MAXIMUM	MINIMUM					
A3 44/78	63'-0"	36'-0"	78'-6 1/2"	42'-10 1/2"	35'-8"	7'-10"	25'-8"
A3 48/86	71'-0"	40'-0"	86'-6 1/2"	46'-10 1/2"	39'-8"	9'-10"	29'-8"
A3 50/95	80'-0"	43'-0"	95'-6 1/2"	49'-10 1/2"	45'-8"	9'-10"	32'-8"
A3 53/104	89'-0"	46'-0"	104'-6 1/2"	52'-10 1/2"	51'-8"	9'-10"	35'-8"
A3 58/110	95'-0"	50'-0"	110'-6 1/2"	56'-10 1/2"	53'-8"	12'-10"	39'-8"
A3 60/119	104'-0"	53'-0"	119'-6 1/2"	59'-10 1/2"	59'-8"	12'-10"	42'-8"
A3 64/131	116'-0"	57'-0"	131'-6 1/2"	63'-10 1/2"	67'-8"	12'-10"	46'-8"
A3 68/141	126'-0"	60'-0"	141'-1 3/4"	67'-1"	74'-0 3/4"	12'-10"	49'-10 1/2"



**GENERAL ARRANGEMENT
APRON DRIVE PASSENGER
BOARDING BRIDGE
(A3 - 125° MODELS)**

NOTES:
1. ALL DIMENSIONS ARE SHOWN THUS: FEET/INCHES METERS

Passenger Boarding Bridge Preventive Maintenance Program

JBT AeroTech, Jetway Systems[®] is pleased to provide the following information to inform you of the requirements associated with the development of a comprehensive preventive maintenance program for passenger boarding bridges. Attached are the preventive maintenance check sheets that outline the scope of work associated with each quarterly preventive maintenance inspection.

Preventive Maintenance:

Preventive maintenance is to be completed per the requirements outlined in our Maintenance Manual. The specific scope of work requirements for each of the scheduled preventive maintenance inspections are identified in the attached Annual, Semi-Annual, and Quarterly Preventive Maintenance Instructions. The preventive maintenance program will need to be scheduled by your local Maintenance Project Manager who will coordinate with airport operations to schedule PBB equipment to be out of service for the duration required for each specific maintenance check. In most cases the duration of the maintenance for each PBB will be as follows:

1st Quarter Inspection	4 Hours
2nd Quarter Semi-Annual Inspection	8 Hours
Semi-Annual Power Wash	4 Hours
3rd Quarter Inspection	4 Hours
4th Quarter Inspection Annual Inspection	10 Hours
Annual Power Wash/Touch-Up Painting	6 Hours

There are normally two persons required to execute the preventive maintenance program, so the actual man hours required to complete the maintenance work should be double those shown above.



Apron Drive 2 & 3 Tunnel Passenger Boarding Bridge

Quarterly Preventive Maintenance

DESCRIPTION		DATE	GOOD	REPAIRED or LUBRICATED	MECHANIC
1.	Drive the bridge to all limits to detect any operational problems.				
2.	Manipulate the following limit switches by hand making sure they work properly:				
	a. Rotunda Rotation				
	b. Slope Limits				
3.	Check Cab Rotation				
	a. Rotate the cab full right and left. Operation should be smooth.				
4.	Check canopy closure operation.				
	NOTE: When checking the canopy do not place the bridge against an aircraft.				
	a. Left side raise - the motor will stop running when the canopy is full up.				
	b. Right side raise - the motor will stop running when the canopy is full up.				
	c. Lower the canopy, either side, a few inches. The canopy down message will appear and the bridge will not drive forward.				
	d. Left side down - extend the curtain until the clutch is engaged indicated by a clicking sound.				
	e. Right side down - extend the curtain until the clutch is engaged indicated by a clicking sound.				
5.	Horizontal Drive				



Apron Drive 2 & 3 Tunnel Passenger Boarding Bridge

Quarterly Preventive Maintenance

DESCRIPTION		DATE	GOOD	REPAIRED or LUBRICATED	MECHANIC
	a. Drive the bridge full forward - the slow down circuit will activate about 3 feet before full extend is reached, and the bridge will stop before reaching the mechanical stops.				
	b. Drive the bridge full reverse - the slow down circuit will activate about 3 feet before full retract is reached, and the bridge will stop before reaching the mechanical stops.				
	c. Insure the travel warning bell is ringing whenever the bridge is moving.				
	d. Rotate the horizontal drive to its right and left limits. Drive unit should stop at the preset limits.				
NOTE: All movement should be smooth in operation. If the operation is jerky and/or noisy, check for obstructions on the roller tracks.					
6.	Vertical Drive				
	a. Raise and lower the bridge - operation should be smooth.				
	b. Raise and lower the bridge to its upper and lower limits. The bridge should stop at the preset heights.				
	c. Inspect vertical lift column chain coupling (See chapter 4 Section 3 for procedures).				
7.	Vertical lift column fault limit switches.				
NOTE: Check only one limit switch at a time.					



Apron Drive 2 & 3 Tunnel Passenger Boarding Bridge

Quarterly Preventive Maintenance

DESCRIPTION		DATE	GOOD	REPAIRED or LUBRICATED	MECHANIC
	a. Remove limit switch and manually trip while a second person attempts to raise or lower the bridge. If the bridge raises or lowers the limit switch must be replaced.				
	b. Repeat this procedure on the other limit switch.				
NOTE: Any shims that are removed or that may fall free during this process must be replaced before re-securing the limit switches.					
8.	Inspect the operators console.				
	a. Check for moisture, rust, and debris.				
	b. Check all printed circuit boards, wire connections and other components for secure mounting.				
	c. Check for any evidence of arching or pitting signaling loose connections.				
	d. Indicator lights, meters and wiring in general.				
9.	Observe the cable carrier system while retracting and extending the bridge to insure system does not bind.				
10.	Check rotunda access panel and hold down clamps for secure mounting.				
11.	Check rotunda side curtains for tightness and adjust if necessary.				
12.	Check cab side curtains for tightness and adjust if necessary.				
13.	Check the following electrical cables for deterioration and general condition.				
	a. Exposed cables under tunnels.				



Apron Drive 2 & 3 Tunnel Passenger Boarding Bridge

Quarterly Preventive Maintenance

DESCRIPTION	DATE	GOOD	REPAIRED or LUBRICATED	MECHANIC
b. Exposed cables under cab.				
c. Cables from rotunda to tunnel A.				
d. 400Hz Aircraft power input cable (if applicable)				
14. Check tunnel equalizing cable and adjust if necessary.				
15. Auto Level				
a. Check the set screws holding the wheel to the limit switch, they should be tight.				
b. Turn the wheel by hand in both directions insuring freedom of operation and positive return to neutral.				
NOTE: Turning the wheel approximately 15° in either direction will engage the limit switch.				
c. Check the arm - it should move freely in both directions.				
d. Check the auto level travel limits with the arm extended and the bridge in "AUTO LEVEL" mode.				
By hand turn and hold the wheel to simulate the aircraft rising. About 4 seconds will pass before the auto level warning light and bell come on.				
Reset the auto level system and check the down travel by turning and holding the wheel in the opposite direction. About 4 seconds will pass and the warning light and bell come on.				



Apron Drive 2 & 3 Tunnel Passenger Boarding Bridge

Quarterly Preventive Maintenance

DESCRIPTION	DATE	GOOD	REPAIRED or LUBRICATED	MECHANIC
16. Lift the console faceplate and clean the touch screen and the glass cover with a good quality glass cleaner.				
17. Lubricate the following:				
NOTE: See Chapter 2, Section 3 for lubrication points and Chapter 2, Section 4 for the Table of Lubricants.				
a. Vertical lift column ball screw assembly through the oil cup on top of each column using lube spec #2. Use 6 oz. of lubricant.				
NOTE: After lubrication the bridge must be driven to extreme UP and DOWN limits several times to insure proper distribution of the lubricant.				



**Apron Drive 2 & 3 Tunnel
Passenger Boarding Bridge**

Semi-Annual Preventive Maintenance

DESCRIPTION	DATE	GOOD	REPAIRED or LUBRICATED	MECHANIC
1. Drive the bridge to all limits to detect any operational problems.				
2. Manipulate the following limit switches by hand making sure they work properly:				
a. Rotunda Rotation				
b. Slope Limits				
3. Check Cab Rotation				
a. Rotate the cab full right and left. Operation should be smooth.				
4. Check canopy closure operation.				
NOTE: When checking the canopy do not place the bridge against an aircraft.				
a. Left side raise - the motor will stop running when the canopy is full up.				
b. Right side raise - the motor will stop running when the canopy is full up.				
c. Lower the canopy, either side, a few inches. The canopy down message will appear on the CRT and the bridge will not drive forward.				
d. Left side down - extend the curtain until the clutch is engaged indicated by a clicking sound.				
e. Right side down - extend the curtain until the clutch is engaged indicated by a clicking sound.				
5. Horizontal Drive				
a. Drive the bridge full forward - the slow down circuit will activate about three feet before full extend is reached, and the bridge will stop before reaching the mechanical stops.				
b. Drive the bridge full reverse - the slow down circuit will activate about three feet before full retract is reached, and the bridge will stop before reaching the mechanical stops.				
c. The travel warning bell is ringing whenever the bridge is moving.				
d. Rotate the horizontal drive to its right and left limits. Drive unit should stop at the preset limits.				



**Apron Drive 2 & 3 Tunnel
Passenger Boarding Bridge**

Semi-Annual Preventive Maintenance

DESCRIPTION	DATE	GOOD	REPAIRED or LUBRICATED	MECHANIC
NOTE: All movement should be smooth in operation. If the operation is jerky and/or noisy, check for obstructions on the roller tracks.				
6.	Vertical Drive			
	a. Raise and lower the bridge - operation should be smooth.			
	b. Raise and lower the bridge to its upper and lower limits. The bridge should stop at the preset heights.			
	c. Inspect vertical lift column chain coupling (See chapter 4 Section 3 for procedures).			
7.	Vertical lift column fault limit switches.			
NOTE: Check only one limit switch at a time.				
	a. Remove limit switch and manually trip while a second person attempts to raise or lower the bridge. If the bridge raises or lowers the limit switch must be replaced.			
	b. Repeat this procedure on the other limit switch.			
NOTE: Any shims that are removed or that may fall free during this process must be replaced before re-securing the limit switches.				
8.	Inspect the operator's console.			
	a. Check for moisture, rust, and debris.			
	b. Check all printed circuit boards, wire connections and other components for secure mounting.			
	c. Check for any evidence of arching or pitting signaling loose connections.			
	d. Indicator lights, meters and wiring in general.			
9.	Observe the cable carrier system while retracting and extending the bridge to insure system does not bind.			
10.	Check rotunda access panel and hold down clamps for secure mounting.			
11.	Check rotunda side curtains for tightness and adjust if necessary.			
12.	Check cab side curtains for tightness and adjust if necessary.			



**Apron Drive 2 & 3 Tunnel
Passenger Boarding Bridge**

Semi-Annual Preventive Maintenance

DESCRIPTION		DATE	GOOD	REPAIRED or LUBRICATED	MECHANIC
13.	Check the following electrical cables for deterioration and general condition.				
	a. Exposed cables under tunnels.				
	b. Exposed cables under cab.				
	c. Cables from rotunda to tunnel A.				
	d. 400Hz Aircraft power input cable (if applicable)				
14.	Check tunnel equalizing cable and adjust if necessary.				
15.	Auto Level				
	a. Check the set screws holding the wheel to the limit switch, they should be tight.				
	b. Turn the wheel by hand in both directions insuring freedom of operation and positive return to neutral.				
	NOTE: Turning the wheel approximately 15° in either direction will engage the limit switch.				
	c. Check the arm - it should move freely in both directions.				
	d. Check the auto level travel limits with the arm extended and the CRT in the "AUTO LEVEL" mode.				
	By hand turn and hold the wheel to simulate the aircraft rising. About 4 seconds will pass before the auto level warning light and bell come on.				
	Reset the auto level system, check the down travel by turning and holding the wheel in the opposite direction. About 4 seconds will pass before the warning light and bell come on.				
16.	Lift the console faceplate and clean the touch screen and the glass cover with a good quality glass cleaner.				
17.	Check the following weather seals for general condition:				
	a. rotunda to building				
	b. splice seals, if applicable				



**Apron Drive 2 & 3 Tunnel
Passenger Boarding Bridge**

Semi-Annual Preventive Maintenance

DESCRIPTION	DATE	GOOD	REPAIRED or LUBRICATED	MECHANIC
c. bellows seals between tunnels, if applicable.				
18. Thoroughly wash bridge exterior as per Chapter 2, Section 10.				
19. Inspect exterior paint for chips, cracks and rust.				
20. Check tunnel roller tracking and adjust if necessary.				
21. Inspect interior paint for chips, cracks and rust.				
22. Check the following mounting bolts for tightness:				
a. Horizontal Drive				
b. Vertical Lift Column				
c. Landing				
d. Rotunda Column Splice, if applicable				
e. Walkway Haunch Splice, if applicable				
<p>NOTE: If any of the above mounting bolts are loose, they must be replaced with ASTM A325 bolts (refer to Fastener Identification Chart in Appendix A), ASTM 563 nuts (identified by three (3) radial lines on nut), and flat hardened washers. All replacement bolts and nuts should be coated to prevent corrosion. The new bolts should be tightened as described in the Bolt Torque Requirement section of Chapter 4, Section 7. Only remove and replace one bolt at a time.</p> <p>NOTE: The tightening of the new bolt may cause other bolts in the joint to loosen. Therefore, after tightening the new bolt, re-verify the tightness of the remaining bolts. Repeat the procedure until all the bolts are tight. If more than one bolt in a joint is loose, then all of the bolts in the joint should be replaced and tightened (one at a time).</p>				
23. Check rotunda floor alignment				
24. Check drain spouts in tunnel floor gutters. Make certain they are not clogged with debris and will pass water.				
25. Check tires				
a. Check air pressure and fill, if necessary.				
b. Check general condition of tires.				
26. Lubricate the following:				
<p>NOTE: See Chapter 2, Section 3 for lubrication points and Chapter 2, Section 4 for the Table of Lubricants.</p>				
a. Vertical lift column ball screw assembly through the oil cup on top of each column using lube spec #2. Use 6 oz. of lubricant.				



**Apron Drive 2 & 3 Tunnel
Passenger Boarding Bridge**

Semi-Annual Preventive Maintenance

DESCRIPTION	DATE	GOOD	REPAIRED or LUBRICATED	MECHANIC
NOTE: After lubrication the bridge must be driven to extreme UP and DOWN limits several times to insure proper distribution of the lubricant.				
b. Vertical lift column thrust bearings with lube spec #1.				
c. Rotunda column flange and sleeve bearings with lube spec #1.				
d. Cab canopy mechanical parts with lube spec #3.				
1) Actuator pivot point.				
2) Lower actuator arm pivot point.				
3) Lower actuator arm bushings.				
4) Pivot Block				
5) Lower hinges				
e. Wheel Carriage and Swivel Column				
1) Drive chains with lube spec #2.				
2) Turret Bearing with lube spec #1.				
3) Bushings and Trunnion pin with lube spec #3				
NOTE: The wheel bearings should be lubricated each time the wheel assemblies are torn down with lube spec #3.				
f. Cable lift arm hinges with lube spec #3.				
g. Cab rotation parts as follows:				
1) Drive chains with lube spec #2.				
2) Sprocket shafts with lube spec #3.				
27. After lubrication operate the bridge to all limits to distribute lubrication.				



**Apron Drive 2 & 3 Tunnel
Passenger Boarding Bridge**

Annual Preventive Maintenance

Page 1

DESCRIPTION	DATE	GOOD	REPAIRED or LUBRICATED	MECHANIC
1. Drive the bridge to all limits to detect any operational problems.				
2. Manipulate the following limit switches by hand making sure they work properly:				
a. Rotunda Rotation				
b. Slope Limits				
3. Check Cab Rotation				
a. Rotate the cab full right and left. Operation should be smooth.				
4. Check canopy closure operation.				
NOTE: When checking the canopy do not place the bridge against an aircraft.				
a. Left side raise - the motor will stop running when the canopy is full up.				
b. Right side raise - the motor will stop running when the canopy is full up.				
c. Lower the canopy, either side, a few inches. The canopy down message will appear on the monitor and the bridge will not drive forward.				
d. Left side down - extend the curtain until the clutch is engaged indicated by a clicking sound.				
e. Right side down - extend the curtain until the clutch is engaged indicated by a clicking sound.				
5. Horizontal Drive				



**Apron Drive 2 & 3 Tunnel
Passenger Boarding Bridge**

Annual Preventive Maintenance

Page 2

DESCRIPTION	DATE	GOOD	REPAIRED or LUBRICATED	MECHANIC
a. Drive the bridge full forward - the slow down circuit will activate about 3 feet before full extend is reached, and the bridge will stop before reaching the mechanical stops.				
b. Drive the bridge full reverse - the slow down circuit will activate about 3 feet before full retract is reached, and the bridge will stop before reaching the mechanical stops.				
c. Insure the travel warning bell is ringing whenever the bridge is moving.				
d. Rotate the horizontal drive to its right and left limits. Drive unit should stop at the preset limits.				
NOTE: All movement should be smooth in operation. If the operation is jerky and/or noisy, check for obstructions on the roller tracks.				
6. Vertical Drive				
a. Raise and lower the bridge - operation should be smooth.				
b. Raise and lower the bridge to its upper and lower limits. The bridge should stop at the preset heights.				
c. Inspect vertical lift column chain coupling (See chapter 4 Section 3 for procedures).				
7. Vertical lift column fault limit switches.				
NOTE: Check only one limit switch at a time.				



**Apron Drive 2 & 3 Tunnel
Passenger Boarding Bridge**

Annual Preventive Maintenance

Page 3

	DESCRIPTION	DATE	GOOD	REPAIRED or LUBRICATED	MECHANIC
	a. Remove limit switch and manually trip while a second person attempts to raise or lower the bridge. If the bridge raises or lowers the limit switch must be replaced.				
	b. Repeat this procedure on the other limit switch.				
	NOTE: Any shims that are removed or that may fall free during this process must be replaced before re-securing the limit switches.				
8.	Inspect the operators console.				
	a. Check for moisture, rust, and debris.				
	b. Check all printed circuit boards, wire connections and other components for secure mounting.				
	c. Check for any evidence of arching or pitting signaling loose connections.				
	d. Indicator lights, meters and wiring in general.				
9.	Observe the cable carrier system while retracting and extending the bridge to insure system does not bind.				
10.	Check rotunda access panel and hold down clamps for secure mounting.				
11.	Check rotunda side curtains for tightness and adjust if necessary.				
12.	Check cab side curtains for tightness and adjust if necessary.				
13.	Check the following electrical cables for deterioration and general condition.				
	a. Exposed cables under tunnels.				



**Apron Drive 2 & 3 Tunnel
Passenger Boarding Bridge**

Annual Preventive Maintenance

Page 4

DESCRIPTION		DATE	GOOD	REPAIRED or LUBRICATED	MECHANIC
	b. Exposed cables under cab.				
	c. Cables from rotunda to tunnel A.				
	d. 400Hz Aircraft power input cable (if applicable)				
14.	Check tunnel equalizing cable and adjust if necessary.				
15.	Auto Level				
	a. Check the set screws holding the wheel to the limit switch, they should be tight.				
	b. Turn the wheel by hand in both directions insuring freedom of operation and positive return to neutral.				
NOTE: Turning the wheel approximately 15° in either direction will engage the limit switch.					
	c. Check the arm - it should move freely in both directions.				
	d. Check the auto level travel limits with the arm extended and the monitor in the "AUTO LEVEL" mode.				
	By hand turn and hold the wheel to simulate the aircraft rising. About 4 seconds will pass before the auto level warning light and bell come on.				
	Reset the auto level system and check the down travel by turning and holding the wheel in the opposite direction. About 4 seconds will pass and the warning light & bell come on.				



**Apron Drive 2 & 3 Tunnel
Passenger Boarding Bridge**

Annual Preventive Maintenance

Page 5

	DESCRIPTION	DATE	GOOD	REPAIRED or LUBRICATED	MECHANIC
16.	Lift the console faceplate and clean the touch screen and the glass cover with a good quality glass cleaner.				
17.	Check the following weather seals for general condition:				
	a. rotunda to building				
	b. splice seals, if applicable				
	c. bellows seals between tunnels, if applicable.				
18.	Thoroughly wash bridge exterior as per Chapter 2, Section 10.				
19.	Inspect exterior paint for chips, cracks and rust.				
20.	Check tunnel roller tracking and adjust if necessary.				
21.	Inspect interior paint for chips, cracks and rust.				
22.	Check the following mounting bolts for tightness:				
	a. Horizontal Drive				
	b. Vertical Lift Column				
	c. Landing				
	d. Rotunda Column Splice, if applicable				
	e. Walkway Haunch Splice, if applicable				
	<p>NOTE: If any of the above mounting bolts are loose, they must be replaced with ASTM A325 bolts (refer to Fastener Identification Chart in Appendix A), ASTM 563 nuts (identified by three (3) radial lines on nut), and flat hardened washers. All replacement bolts and nuts should be coated to prevent corrosion. The new bolts should be tightened as described in the Bolt Torque Requirement section of Chapter 4, Section 7. Only remove and replace one bolt at a time.</p>				



**Apron Drive 2 & 3 Tunnel
Passenger Boarding Bridge**

Annual Preventive Maintenance

Page 6

	DESCRIPTION	DATE	GOOD	REPAIRED or LUBRICATED	MECHANIC
	<p>NOTE: The tightening of the new bolt may cause other bolts in the joint to loosen. Therefore, after tightening the new bolt, re-verify the tightness of the remaining bolts. Repeat the procedure until all the bolts are tight. If more than one bolt in a joint is loose, then all of the bolts in the joint should be replaced and tightened (one at a time).</p>				
23.	Check rotunda floor alignment				
24.	Check drain spouts in tunnel floor gutters. Make certain they are not clogged with debris and will pass water.				
25.	Check tires				
	a. Check air pressure and fill, if necessary.				
	b. Check general condition of tires.				
26.	Inspect the lift column slide pads (See Chapter 2, Section 8 for procedures)				
27.	Check the horizontal drive chains and sprockets for signs of streaking, cracking, rusting or pitting.				
28.	Inspect the following brakes:				
	NOTE: See Chapter 2, Section 8 for inspection and adjustment procedures.				
	a. Vertical Drive				
	b. Horizontal Drive				
	c. Cab Rotation				
	d. 400 Hz Hoist motor (if equipped)				



**Apron Drive 2 & 3 Tunnel
Passenger Boarding Bridge**

Annual Preventive Maintenance

Page 7

	DESCRIPTION	DATE	GOOD	REPAIRED or LUBRICATED	MECHANIC
29.	Inspect the Vertical Drive ball screw after ten (10) years of service for excessive wear, corrosion, cracking, pitting, gouges or brinelling. If any of these conditions exist, the ball screw may need replacement and further inspection is required. Refer to section 4 - 3 of this manual for ball screw removal and appendix B for inspection procedures. After this initial inspection inspect the ball screw every five (5) years. (See Figure 1)				
30.	Lubricate the following:				
	NOTE: See Chapter 2, Section 3 for lubrication points and Chapter 2, Section 4 for the Table of Lubricants.				
	a. Vertical lift column ball screw assembly through the oil cup on top of each column using lube spec #2. Use 6 oz. of lubricant.				
	NOTE: After lubrication the bridge must be driven to extreme UP and DOWN limits several times to insure proper distribution of the lubricant.				
	b. Vertical lift column thrust bearings with lube spec #1.				
	c. Rotunda column flange and sleeve bearings with lube spec #1.				
	d. Cab canopy mechanical parts with lube spec #3.				
	1) Actuator pivot point.				
	2) Lower actuator arm pivot point.				
	3) Lower actuator arm bushings.				
	4) Pivot Block				
	5) Lower hinges				
	e. Wheel Carriage and Swivel Column				
	1) Drive chains with lube spec #2.				



**Apron Drive 2 & 3 Tunnel
Passenger Boarding Bridge**

Annual Preventive Maintenance

Page 8

	DESCRIPTION	DATE	GOOD	REPAIRED or LUBRICATED	MECHANIC
	2) Turret Bearing with lube spec #1.				
	3) Bushings and Trunnion pin with lube spec #3				
	NOTE: The wheel bearings should be lubricated each time the wheel assemblies are torn down with lube spec #3.				
	f. Cable lift arm hinges with lube spec #3.				
	g. Cab rotation parts as follows:				
	1) Drive chains with lube spec #2.				
	2) Sprocket shafts with lube spec #3.				
	h. Rotunda hinge pins with lube spec #1.				
31.	After lubrication operate the bridge to all limits to distribute lubrication.				

8 7 6 5 4 3 2 1

D
C
B
A

D
C
B
A

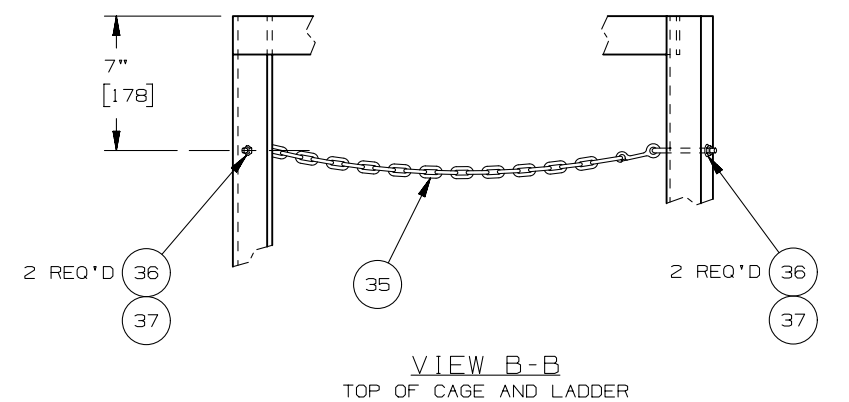
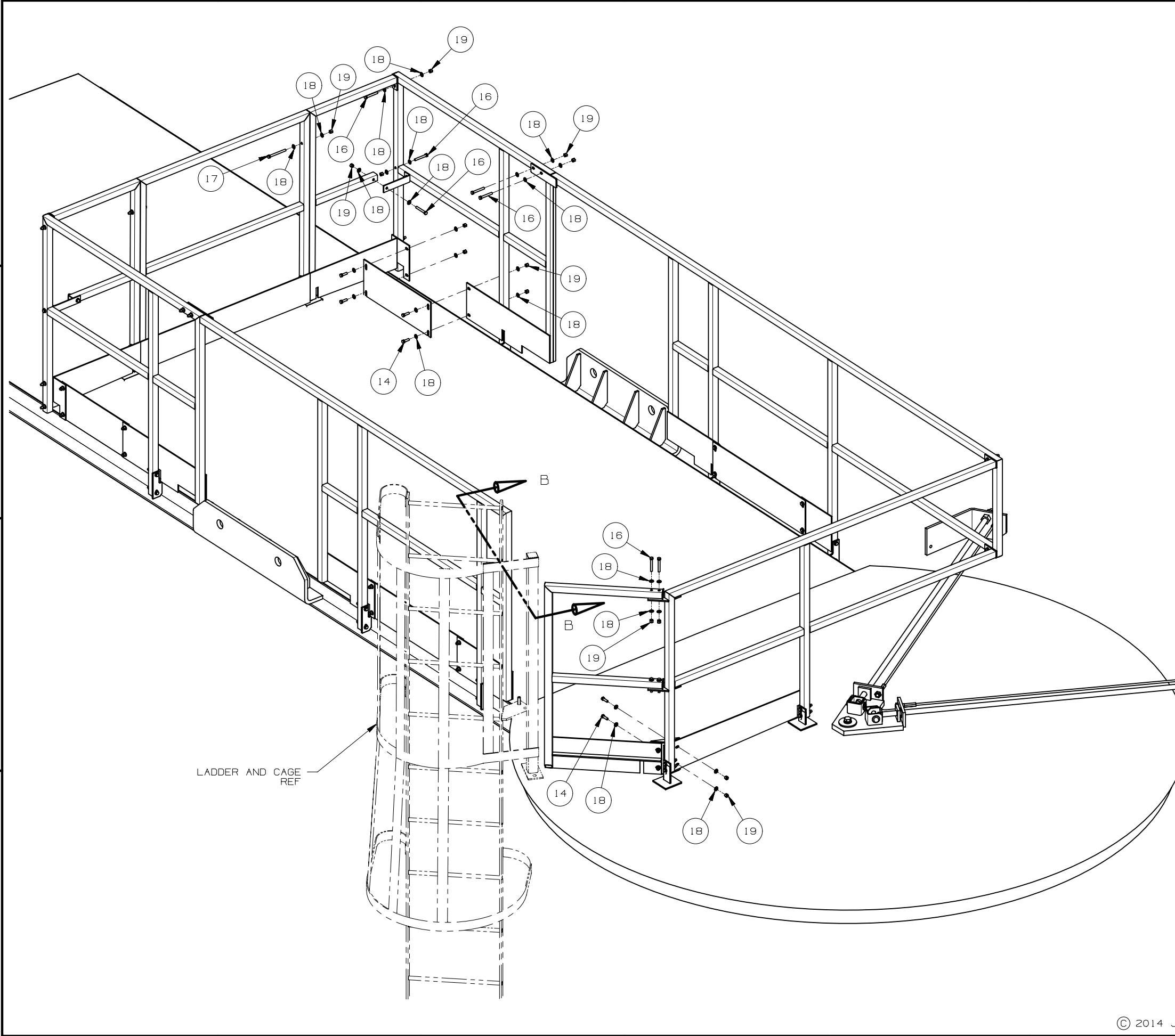

- 3715710 PKL HNDRL ROOF SST FSTNR/CHAIN
- 3713901.WHT KIT HNDRL ROOF FD A3 CFLR CHAIN WHT ARC
- 3713901 KIT HNDRL ROOF FD A3 CFLR PNT
- 3707138.01 KIT HNDRL ROOF FD A3 CFLR CHAIN GALV
- 3707138 KIT HNDRL ROOF FD A3 CFLR GALV
- 3705825 PKL HNDRL ROOF AD PLATFCFLRPNT
- 3705824 PKL HNDRL ROOF AD PLATF CFLR
- 3700150 KIT SAFETY CHAIN MAINT LAD
- 3656789.01 PKL HNDRL ROOF FD FSTNR/SST CHAIN
- 3656789 PKL HNDRL ROOF FD FSTNR/CHAIN
- 3651590 HNDRL ROOF FD A3 CFLR COM
- 2131144.10 KPL FWD ROOF HNDRL GALV/SST HDW
- 2131144.09 HNDRL ROOF FD A3 COM SST HDW
- 2131144.08 HNDRL ROOF FD A3 GALV SST CHAIN
- 2131144.07 HNDRL ROOF FD A3 CFLR PLATF PNT
- 2131144.06 HNDRL ROOF FD A3 CFLR PLATF GALV
- 2131144.05 HNDRL ROOF FD A3 CFLR CHAIN PNT
- 2131144.04 HNDRL ROOF FD A3 CFLR GALV CHAIN
- 2131144.03 HNDRL ROOF FD A3 CFLR PNT
- 2131144.02 HNDRL ROOF FD A3 CFLR GALV

LADDER AND CAGE REF

This drawing and any associated information or amendments are proprietary and confidential to JBT AeroTech. The drawing and information may only be used for the specific contract under which it is delivered and only by the purchaser. Acceptance of the drawing and information constitutes agreement not to reproduce it in whole or in part and not to disclose it to any other party and not use it for any purpose beyond the limited license granted herein without prior written consent.		 Jetway® Systems	
Limits On Dimensions Unless Otherwise Specified .0 ±.1 Angular ± 0° 30' .00 ±.03 Fractional ± 1/16 .000 ±.010 XX ✓ SAE B46.1 Break Sharp Edges .010 Min R		 THIRD ANGLE PROJECTION	
Drn. GW 2000/04/13 Redrn. SED 2014/09/26 Appd.		DO NOT SCALE DRAWING DRAWING SIZE B	
TITLE HNDRL FOLD DN A3 CFLR		PART NUMBER 2131144	
© 2014 JBT AeroTech		Scale Code 54077 Sheet 1 OF 8	

8 7 6 5 4 3 2 1 NX

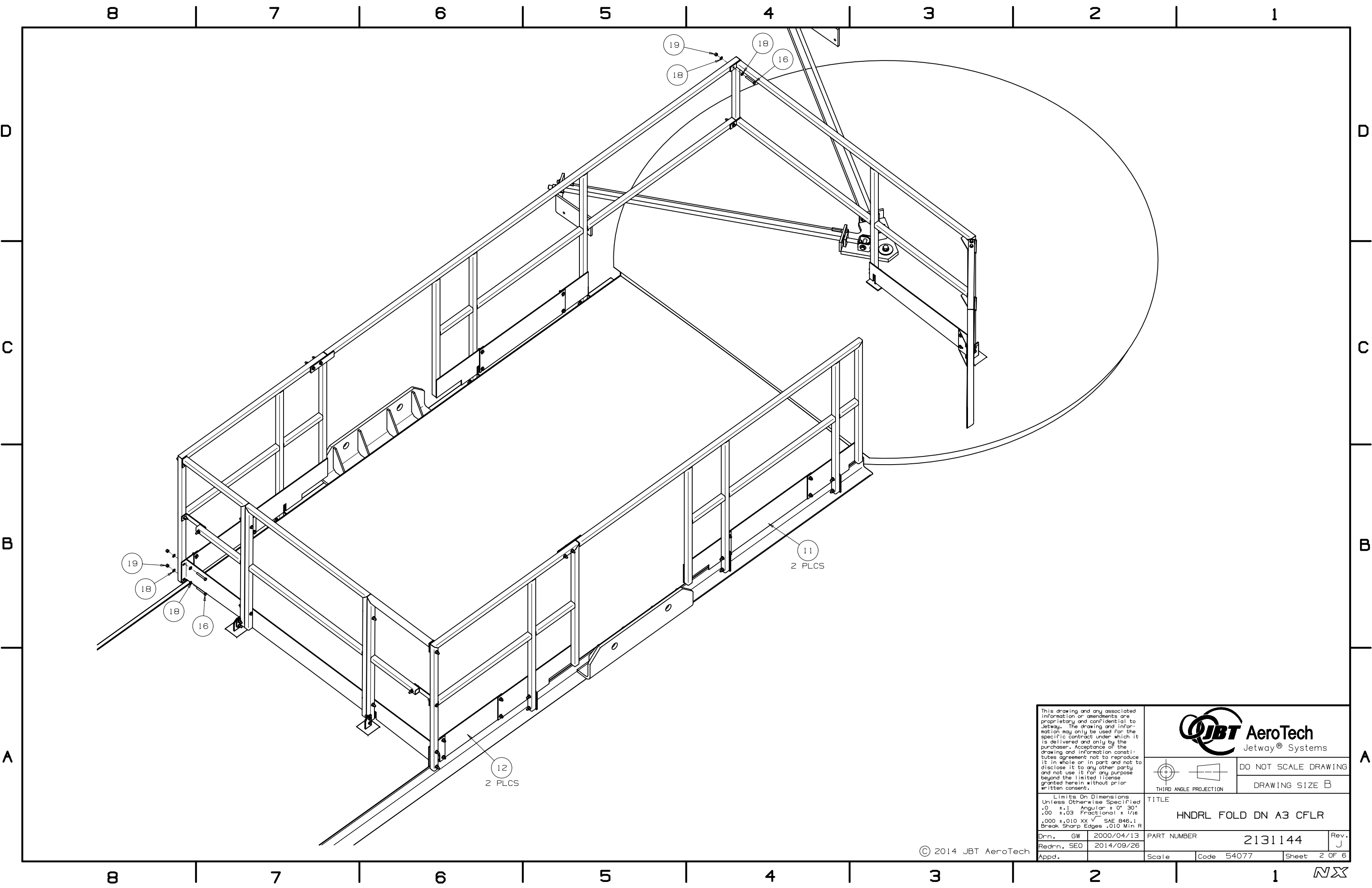

19
18
18
16

19
18
16

11
2 PLCS

12
2 PLCS

This drawing and any associated information or amendments are proprietary and confidential to Jetway. The drawing and information may only be used for the specific contract under which it is delivered and only by the purchaser. Acceptance of the drawing and information constitutes agreement not to reproduce it in whole or in part and not to disclose it to any other party and not use it for any purpose beyond the limited license granted herein without prior written consent.

Limits On Dimensions Unless Otherwise Specified
 .0 ±.1 Angular ± 0° 30'
 .00 ±.03 Fractional ± 1/16
 .000 ±.010 XX ✓ SAE B46.1
 Break Sharp Edges .010 Min R

Drn.	GW	2000/04/13
Redrn.	SEO	2014/09/26
Appd.		

JBT AeroTech
Jetway® Systems

THIRD ANGLE PROJECTION

DO NOT SCALE DRAWING
DRAWING SIZE B

TITLE
HNDRL FOLD DN A3 CFLR

PART NUMBER	2131144	Rev. J
Scale	Code 54077	Sheet 2 OF 6

© 2014 JBT AeroTech

NX

8 7 6 5 4 3 2 1

D

D

C

C

B

B

A

A

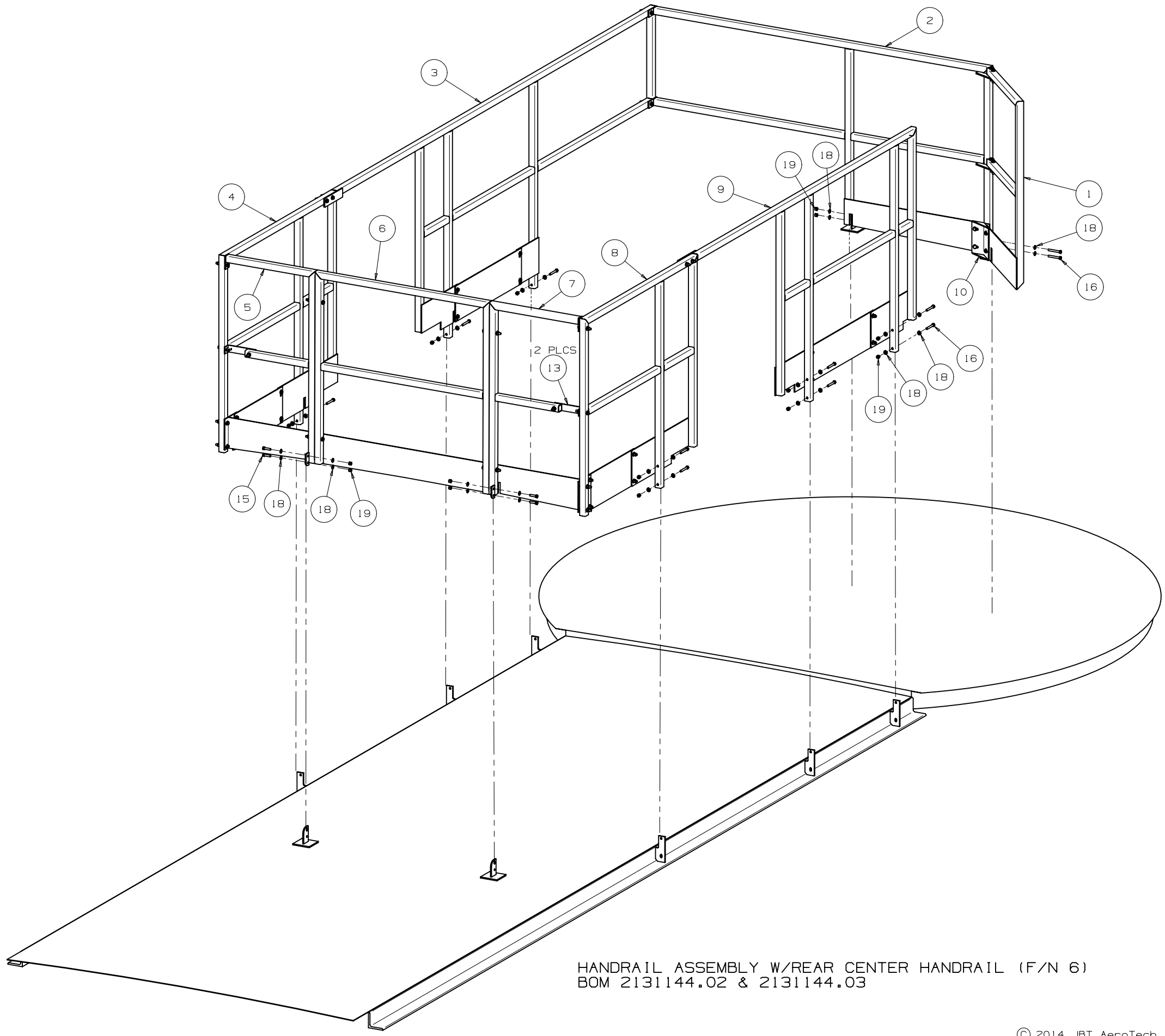

HANDRAIL ASSEMBLY W/REAR CENTER HANDRAIL (F/N 6)
 BOM 2131144.02 & 2131144.03

<p>This drawing and any associated information or amendments are proprietary and confidential to Jetway. The drawing and information may only be used for the specific contract under which it is delivered and only by the purchaser. Acceptance of the drawing and information constitutes agreement not to reproduce it in whole or in part and not to disclose it to any other party and not use it for any purpose beyond the limited license granted herein without prior written consent.</p>			
<p>THIRD ANGLE PROJECTION</p>		<p>DO NOT SCALE DRAWING DRAWING SIZE B</p>	
<p>Limits On Dimensions Unless Otherwise Specified .0 ±.1 Angular ± 0° 30' .00 ±.03 Fractional ± 1/16 .000 ±.010 XX ✓ SAE B46.1 Break Sharp Edges .010 Min R</p>		<p>TITLE HANDRL FOLD DN A3 CFLR</p>	
<p>Drn. GW 2000/04/13</p>	<p>Redrn. SEO 2014/09/26</p>	<p>PART NUMBER 2131144</p>	<p>Rev. J</p>
<p>Appd.</p>	<p>Scale</p>	<p>Code 54077</p>	<p>Sheet 3 OF 6</p>

© 2014 JBT AeroTech

8 7 6 5 4 3 2 1 NX

8 7 6 5 4 3 2 1

D

D

C

C

B

B

A

A

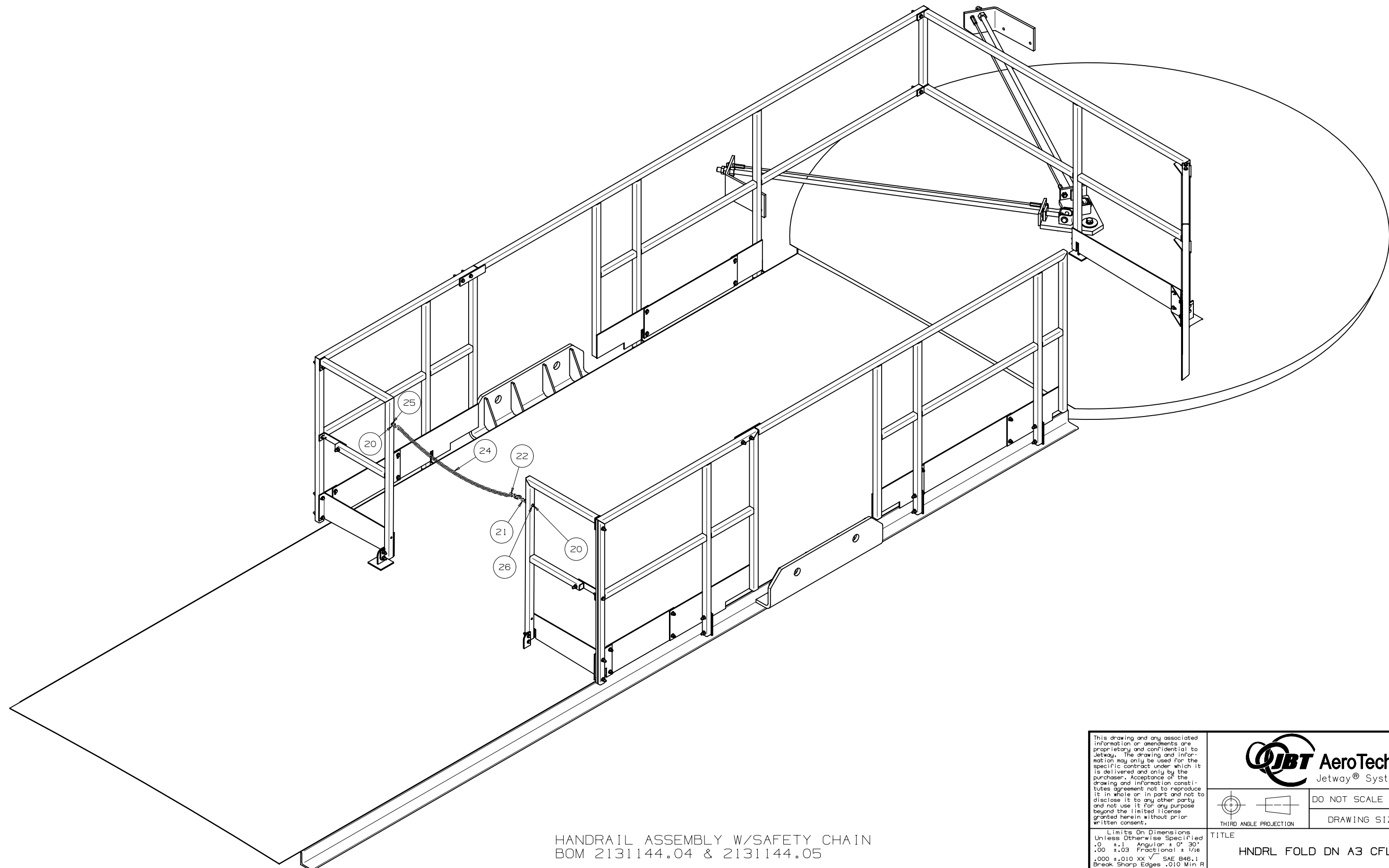

HANDRAIL ASSEMBLY W/SAFETY CHAIN
 BOM 2131144.04 & 2131144.05

<p>This drawing and any associated information or amendments are proprietary and confidential to Jetway. The drawing and information may only be used for the specific contract under which it is delivered and only by the purchaser. Acceptance of the drawing and information constitutes agreement not to reproduce it in whole or in part and not to disclose it to any other party and not use it for any purpose beyond the limited license granted herein without prior written consent.</p>			
<p>THIRD ANGLE PROJECTION</p>		<p>DO NOT SCALE DRAWING</p>	
<p>Limits On Dimensions Unless Otherwise Specified .0 ±.1 Angular ± 0° 30' .00 ±.03 Fractional ± 1/16 .000 ±.010 Xx ✓ SAE B46.1 Break Sharp Edges .010 Min R</p>		<p>TITLE HNDRL FOLD DN A3 CFLR</p>	
<p>Drn. GW 2000/04/13</p>	<p>Redrn. SEO 2014/09/26</p>	<p>PART NUMBER 2131144</p>	<p>Rev. J</p>
<p>Appd.</p>	<p>Scale</p>	<p>Code 54077</p>	<p>Sheet 4 OF 6</p>

© 2014 JBT AeroTech

8 7 6 5 4 3 2 1

NX

8 7 6 5 4 3 2 1

D
C
B
A

SAFETY CHAIN SHOWN
SEE SHT 1 FOR REAR
CENTER HANDRAIL OR
SHT 4 FOR SAFETY CHAIN

REFER TO SHT'S 1, 2 & 3
FOR GENERAL ASSEMBLY
DETAILS

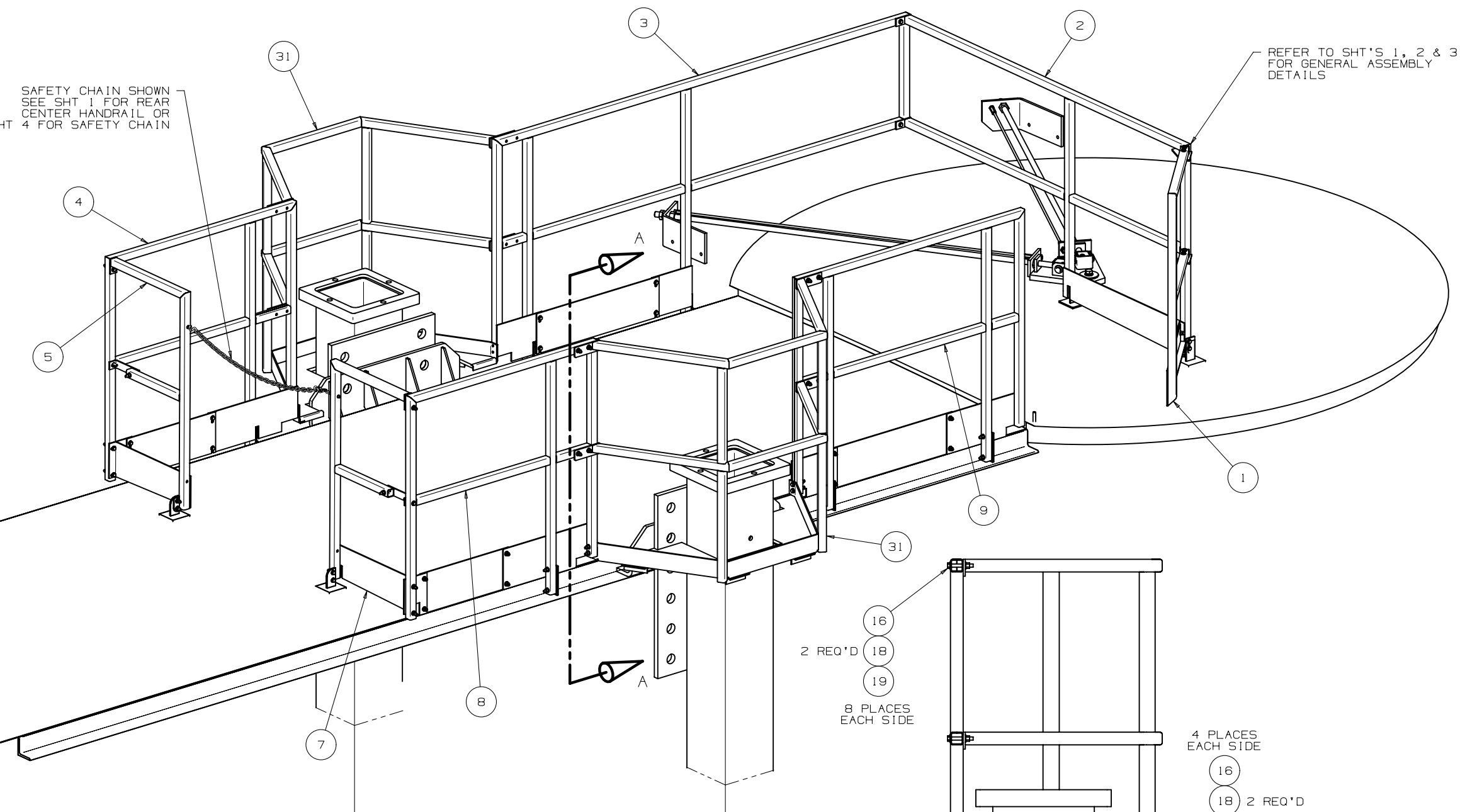

16
18
19
2 REQ'D
8 PLACES
EACH SIDE

16
18 2 REQ'D
19
4 PLACES
EACH SIDE

HANDRAIL ASSEMBLY W/DRIVE COLUMN PLATFORMS
BOM 2131144.06

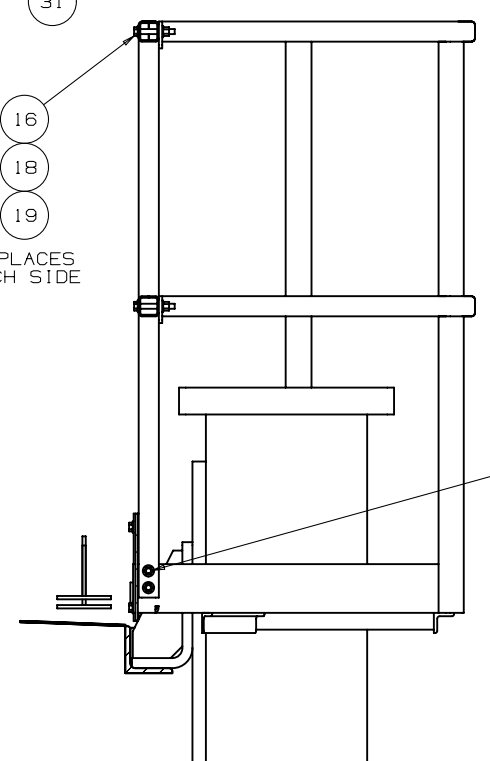

SECTION A - A
R.S. SHOWN
L.S. OPOSITE

<p>This drawing and any associated information or amendments are proprietary and confidential to Jetway. The drawing and information may only be used for the specific contract under which it is delivered and only by the purchaser. Acceptance of the drawing and information constitutes agreement not to reproduce it in whole or in part and not to disclose it to any other party and not use it for any purpose beyond the limited license granted herein without prior written consent.</p>			
<p>Limits On Dimensions Unless Otherwise Specified .0 ±.1 Angular ± 0° 30' .00 ±.03 Fractional ± 1/16 .000 ±.010 XX ✓ SAE B46.1 Break Sharp Edges .010 Min R</p>		<p>THIRD ANGLE PROJECTION</p>	
<p>DO NOT SCALE DRAWING</p>		<p>DRAWING SIZE B</p>	
<p>TITLE HNDRL FOLD DN A3 CFLR</p>			
<p>Drn. GW 2000/04/13</p>	<p>Redrn. SEO 2014/09/26</p>	<p>PART NUMBER 2131144</p>	<p>Rev. J</p>
<p>© 2014 JBT AeroTech</p>		<p>Scale</p>	<p>Code 54077 Sheet 5 OF 6</p>

8 7 6 5 4 3 2 1 NX

8 7 6 5 4 3 2 1

D

D

C

C

B

B

A

A

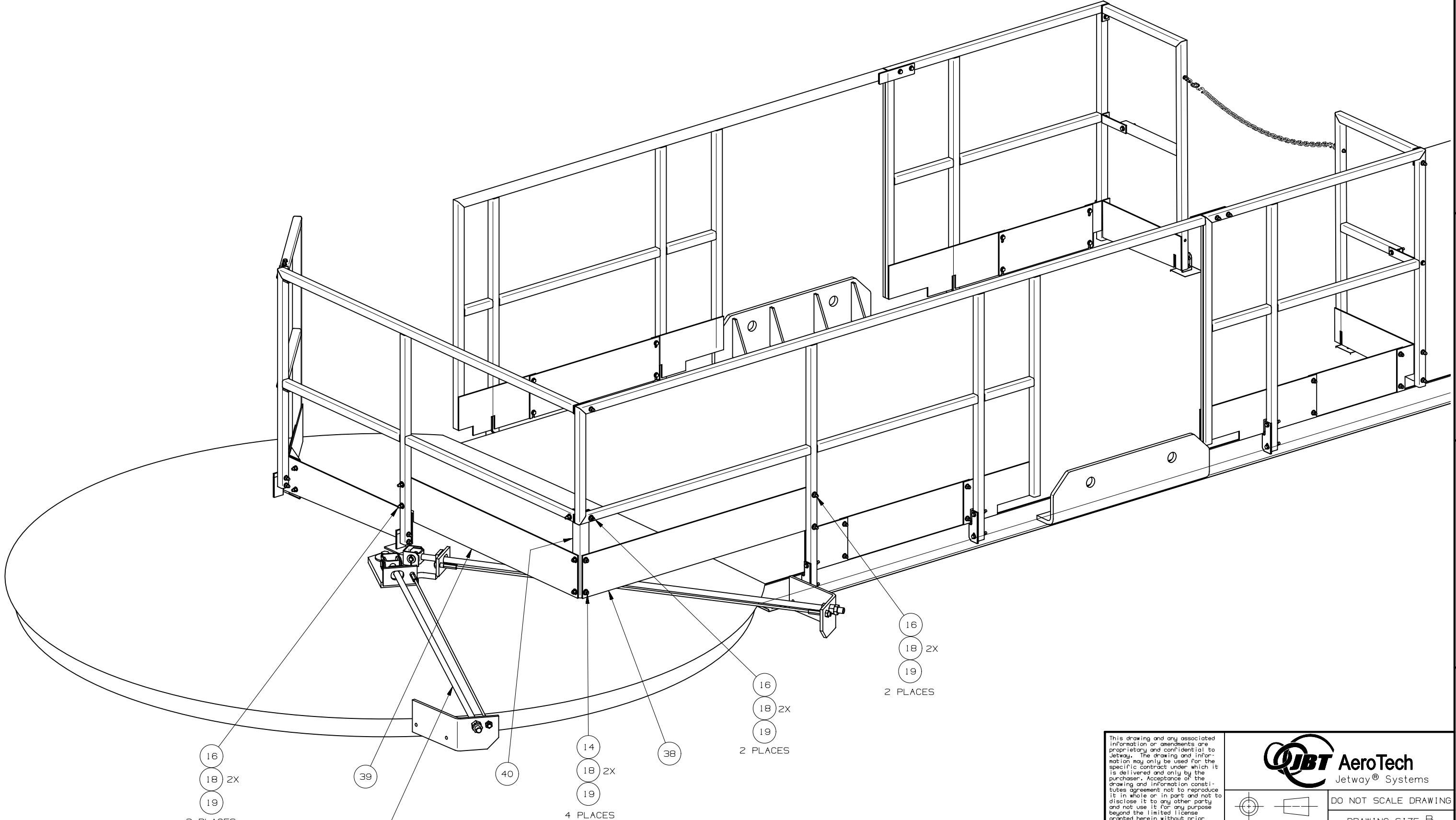

16
18 2X
19
2 PLACES

39

40

14
18 2X
19
4 PLACES

38

16
18 2X
19
2 PLACES

16
18 2X
19
2 PLACES

CAB SUPPORT RODS
SHOWN FOR REFERENCE

OPTIONAL FORWARD KICK PLATES
BOM 2131144.10

This drawing and any associated information or amendments are proprietary and confidential to JBT. The drawing and information may only be used for the specific contract under which it is delivered and only by the purchaser. Acceptance of the drawing and information constitutes agreement not to reproduce it in whole or in part and not to disclose it to any other party and not use it for any purpose beyond the limited license granted herein without prior written consent.

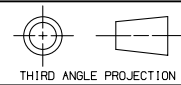

DO NOT SCALE DRAWING
DRAWING SIZE B

Limits On Dimensions
Unless Otherwise Specified
.0 ±.1 Angular ± 0° 30'
.00 ±.03 Fractional ± 1/16
.000 ±.010 XX ✓ SAE B46.1
Break Sharp Edges .010 Min R

TITLE
HANDRL FOLD DN A3 CFLR

Drn. GW 2000/04/13
Redrn. SEO 2014/09/26
Appd.

PART NUMBER 2131144
Scale Code 54077 Sheet 6 OF 6

© 2014 JBT AeroTech

8 7 6 5 4 3 2 1

NX

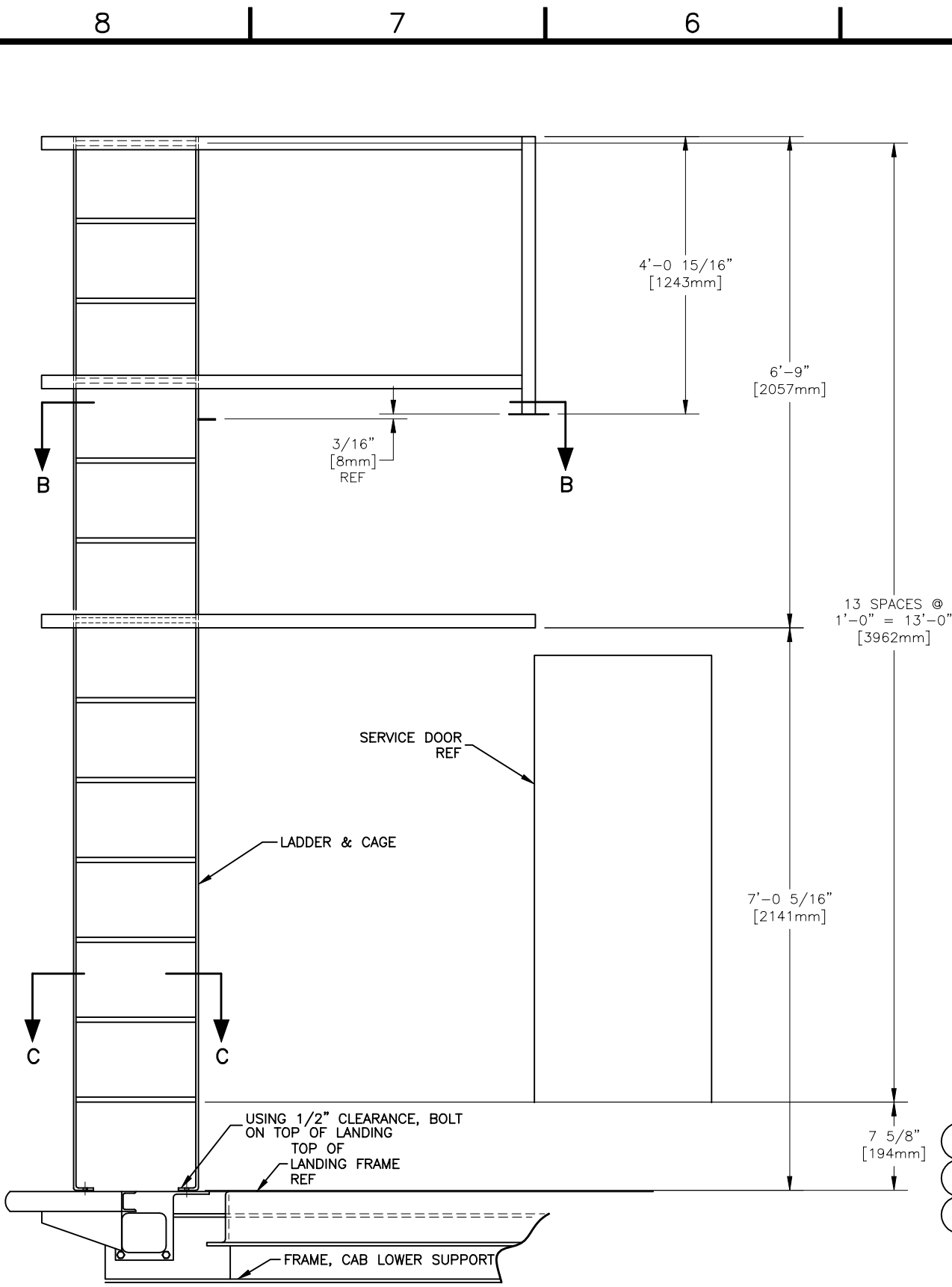

SECTION A-A

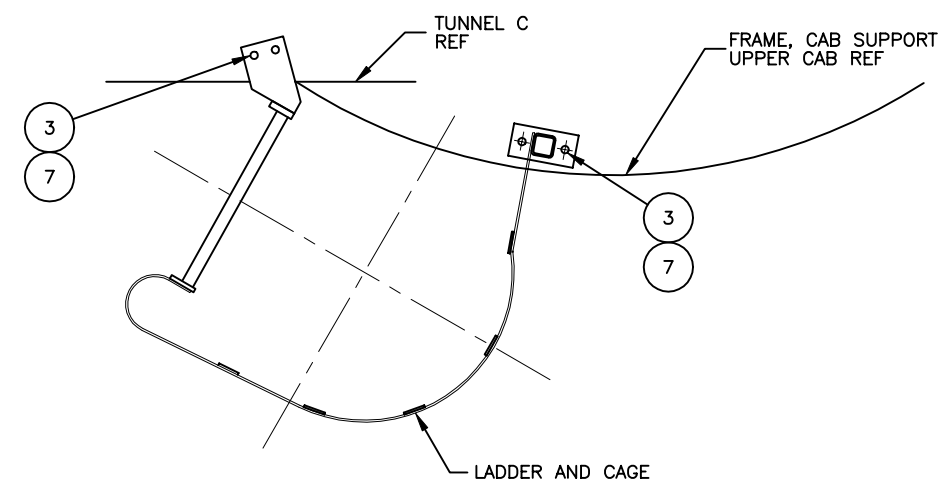

SECTION B-B

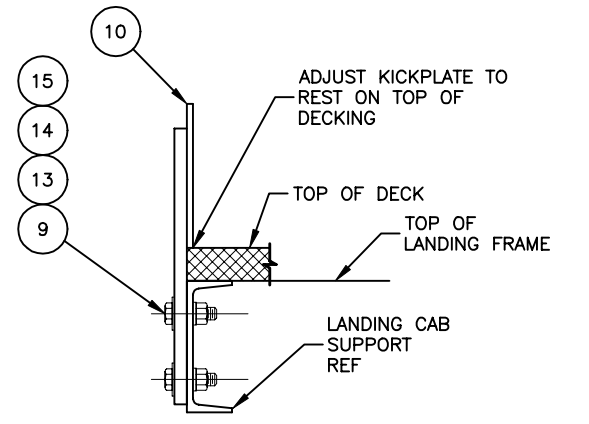

**SECTION D-D
A2 ONLY**

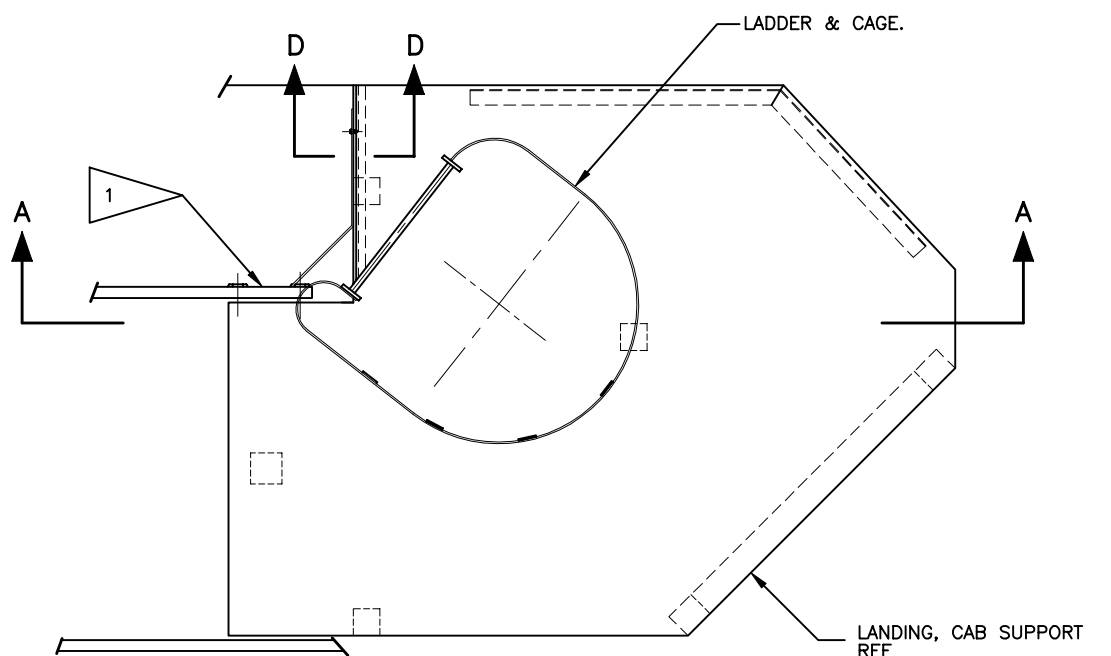

PLAN VIEW

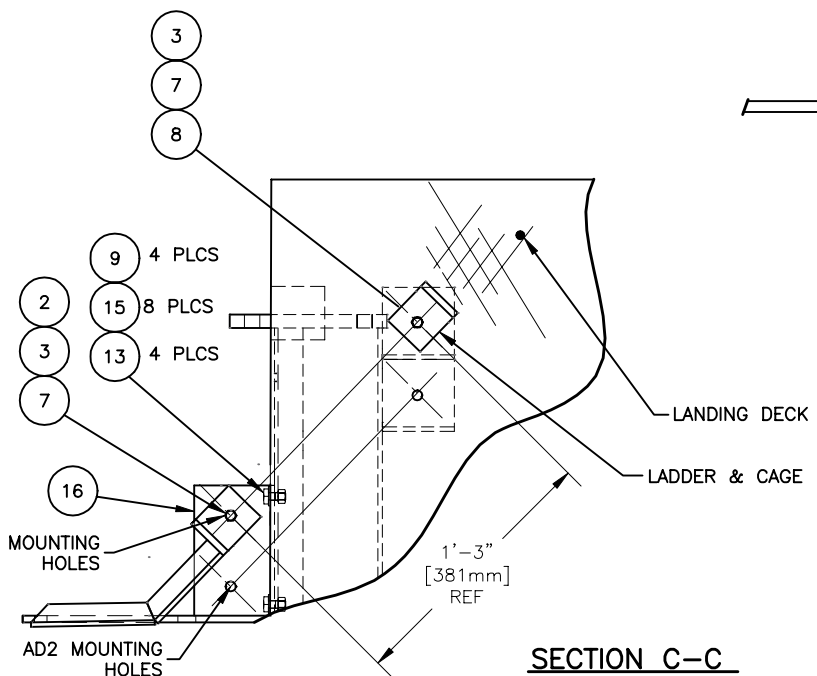

SECTION C-C

- BOM 2135532.04 PKL SERV LAD & CG A3 POLYUREA
- BOM 2135532.03 PKL SERV LAD & CG\LOCK A3 FSTNR
- BOM 2135532.02 PKL SERV LAD & CG A3 FSTNR
- BOM 2135532.01 PKL SERV LAD & CG A2 FSTNR STD

This drawing and any associated information or amendments are proprietary and confidential to Jetway. The drawing and information may only be used for the specific contract under which it is delivered and only by the purchaser. Acceptance of the drawing and information constitutes agreement not to reproduce it in whole or in part and not to disclose it to any other party and not use it for any purpose beyond the limited license granted herein without prior written consent.



LADDER, CAGED
FIELD ASSEMBLY

Drn.	JH	12-03-02	Code	54077
Redrn.	SEO	5-28-04	Scale:	NTS
Appd.				

Drawing	2135532	Rev.	A
Sheet	1 OF 2		

2. DIMENSIONS ARE THUS: FEET-INCHES MILLIMETERS
- 1 DELETE STANDARD HANDRAIL WHEN LADDER AND CAGE ARE USED.

NOTES: UNLESS NOTED OTHERWISE

8 7 6 5 4 3 2 1

D

D

C

C

B

B

A

A

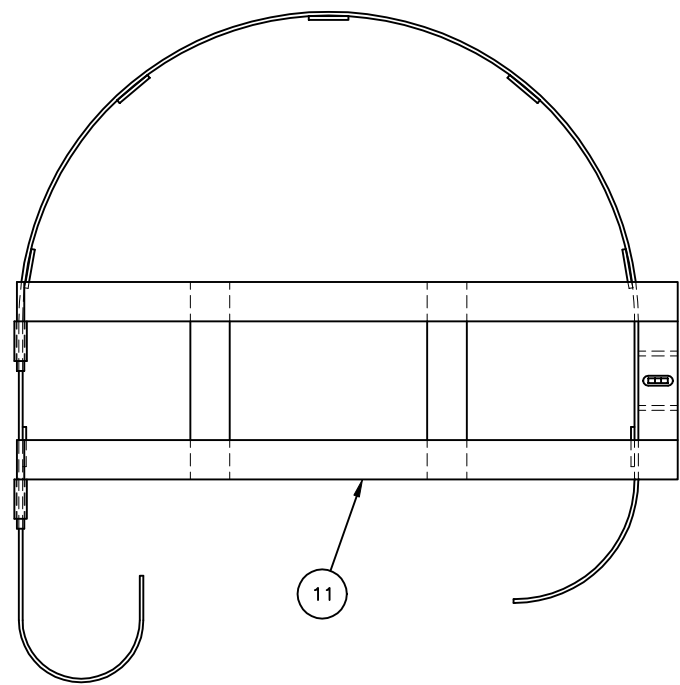
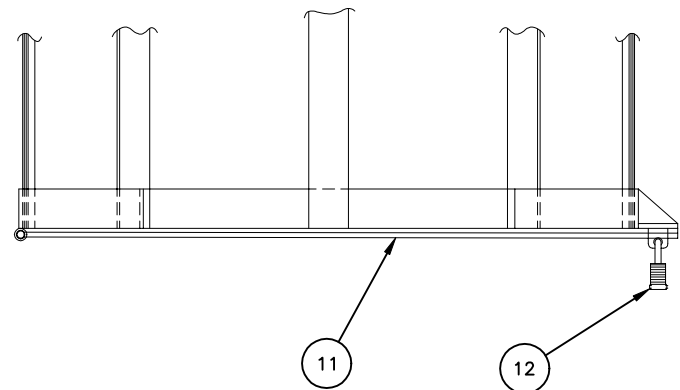

BOTTOM VIEW

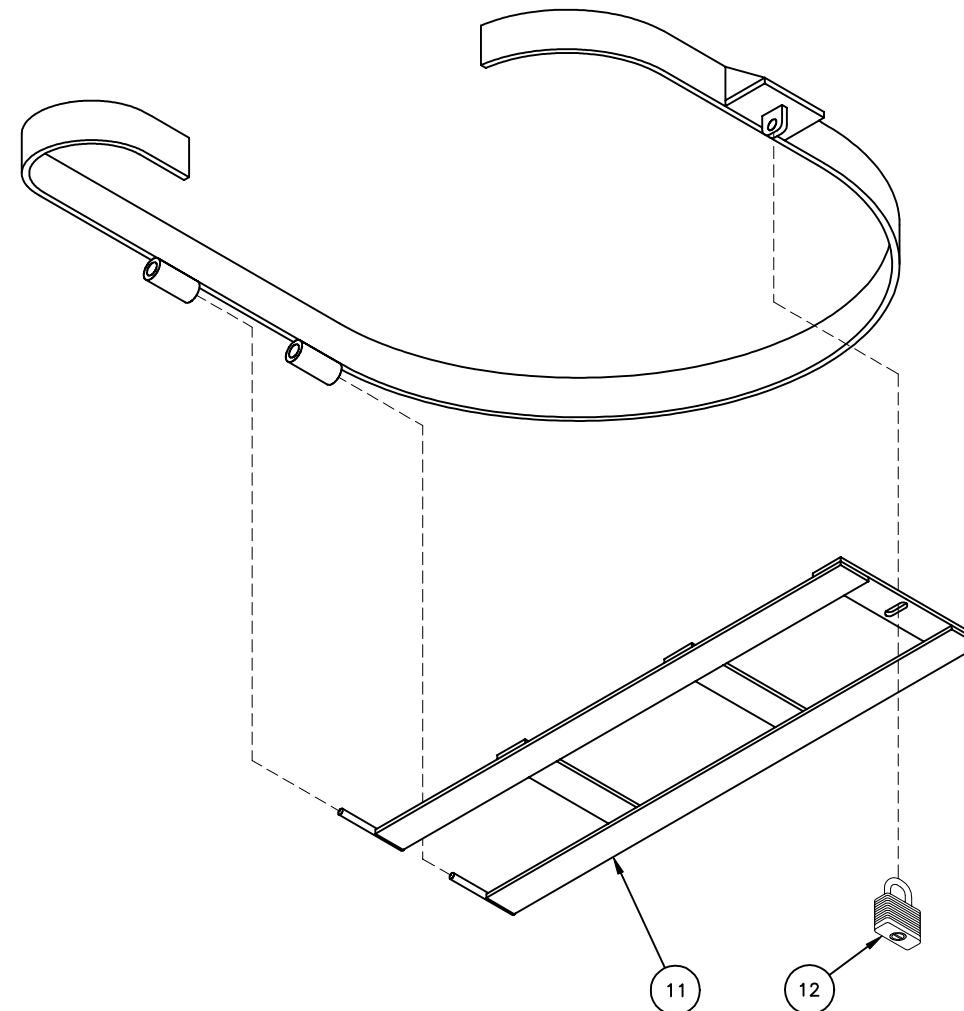

ISO VIEW – OPTIONAL LOCK

ALL PARTS NOT SHOWN FOR CLARITY

This drawing and any associated information or amendments are proprietary and confidential to Jetway. The drawing and information may only be used for the specific contract under which it is delivered and only by the purchaser. Acceptance of the drawing and information constitutes agreement not to reproduce it in whole or in part and not to disclose it to any other party and not use it for any purpose beyond the limited license granted herein without prior written consent.

FMC Airport Systems
Jetway

LADDER, CAGED
FIELD ASSEMBLY

Limits on Dimensions
Unless Otherwise Specified
.0 ± .1 Angular ± 0° 30'
.00 ± .03 Fractional ± 1/16
.000 ± .010 XX SAE 846.1
Break Sharp Edges .010 Min. R.

Drn.	JH	12-03-02
Redrn.	SEO	5-28-04
Appd.		

Code	54077
Scale:	NTS

Drawing	2135532	Rev.	A
Sheet 2 OF 2		AutoCAD	

© 2004 FMC Technologies Inc.

8 7 6 5 4 3 2 1

8 7 6 5 4 3 2 1

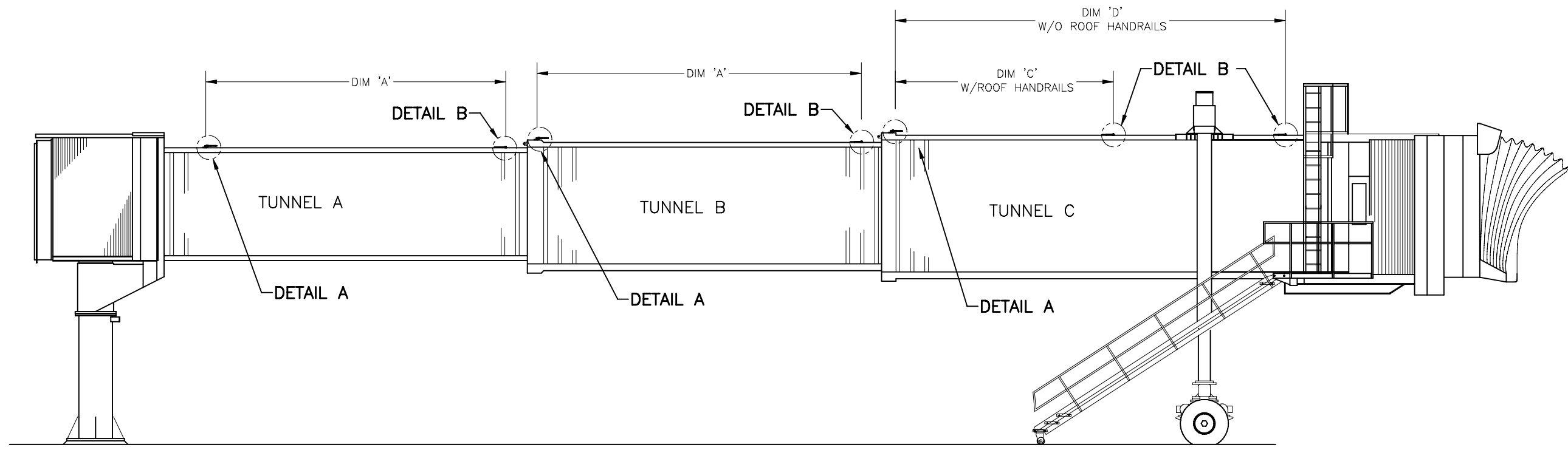

RIGHT SIDE ELEVATION
HANDRAILS OMITTED FOR CLARITY

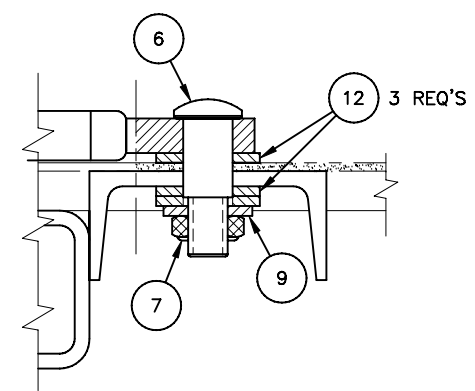

SECTION C-C

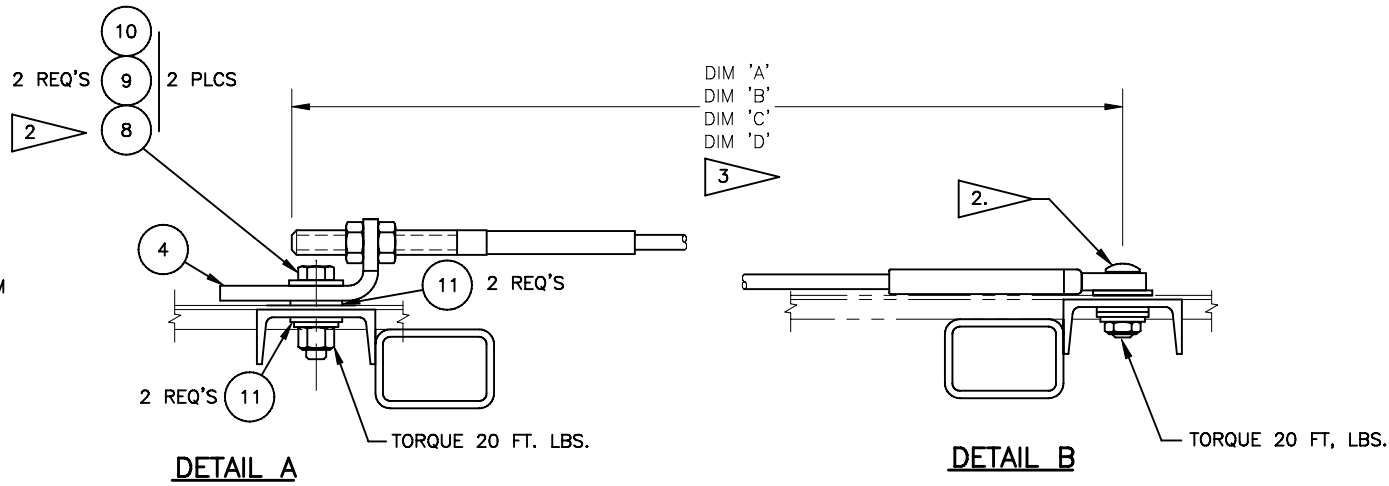
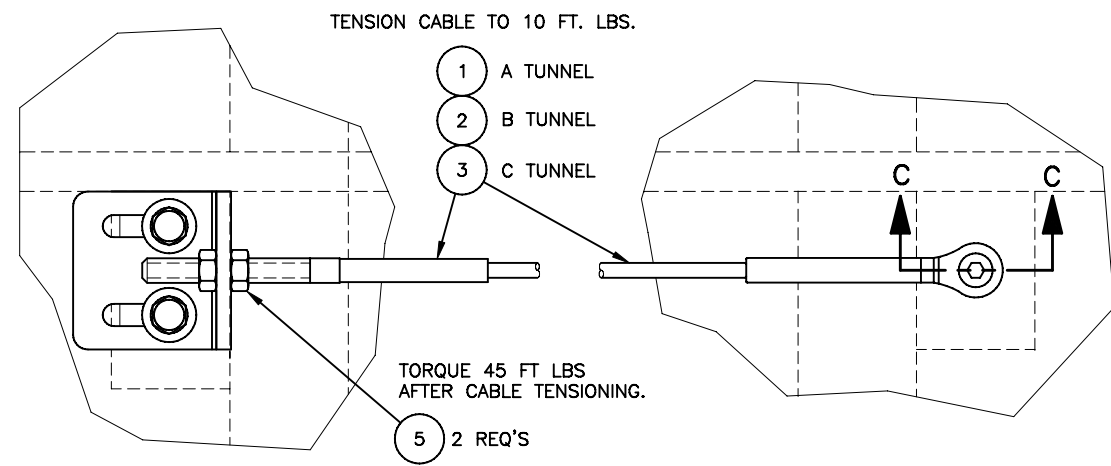

DIMENSION TABLE				
BRIDGE MODEL	DIM 'A' CABLE LENGTH	DIM 'B' CABLE LENGTH	DIM 'C' CABLE LENGTH	DIM 'D' CABLE LENGTH
A3 44/78	15'-2"	15'6 3/8"	7'8 3/4"	20'2 3/4"
A3 48/86	16'7 3/4"	15'5 3/8"	10'6 5/8"	24'2 3/4"
A3 50/95	20'3 3/4"	18'5 3/8"	15'3 1/4"	27'2 3/4"
A3 53/104	21'6"	21'5 3/8"	18'3 1/4"	30'2 3/4"
A3 58/110	25'6"	25'5 3/8"	22'3 1/4"	34'2 3/4"
A3 60/119	28'7 3/4"	28'5 3/8"	25'3 1/4"	37'2 3/4"
A3 64/131	32'6"	32'5 3/8"	29'3 1/4"	41'2 3/4"
A3 68/141	35'8 1/4"	35'5 3/8"	32'5 3/4"	44'5 1/4"

- 3. TO DETERMINE CABLE LENGTH SUBTRACT APPROX 2" FROM DIMENSION SHOWN ON DIMENSION TABLE.
- 2. COAT FASTENER AND THREADS WITH LOCTITE 565 OR 680 AT INSTALLATION
- 1. SET SLOPE LIMIT SWITCHES SO THAT SAFETY LUGS DO NOT INTERFERE WITH RIDGID FRAME WHEN BRIDGE IS ELEVATED IN RETRACTED POSITION.

NOTES: UNLESS OTHERWISE SPECIFIED.

This drawing and any associated information or amendments are proprietary and confidential to JBT AeroTech. The drawing and information may only be used for the specific contract under which it is delivered and only by the purchaser. Acceptance of the drawing and information constitutes agreement not to reproduce it in whole or in part and not to disclose it to any other party and not use it for any purpose beyond the limited license granted herein without prior written consent.



DO NOT SCALE DRAWING
DRAWING SIZE .
THIRD ANGLE PROJECTION

Limits on Dimensions Unless Otherwise Specified
 .0 ± .1 Angular ± 0° 30'
 .00 ± .03 Fractional ± 1/16
 .000 ± .010 XX ✓ SAE B46.1
 Break Sharp Edges .010 Min. R.

Title
MAINTENANCE ROOF CABLE INSTALLATION A3

Drn. TP 11-2-11
 Redrn. TP 1-11-12
 Appd. MDL 1-11-12

Part Number
2139223
 Scale: NTS Code 54077 Sheet 1 OF 1

8 7 6 5 4 3 2 1

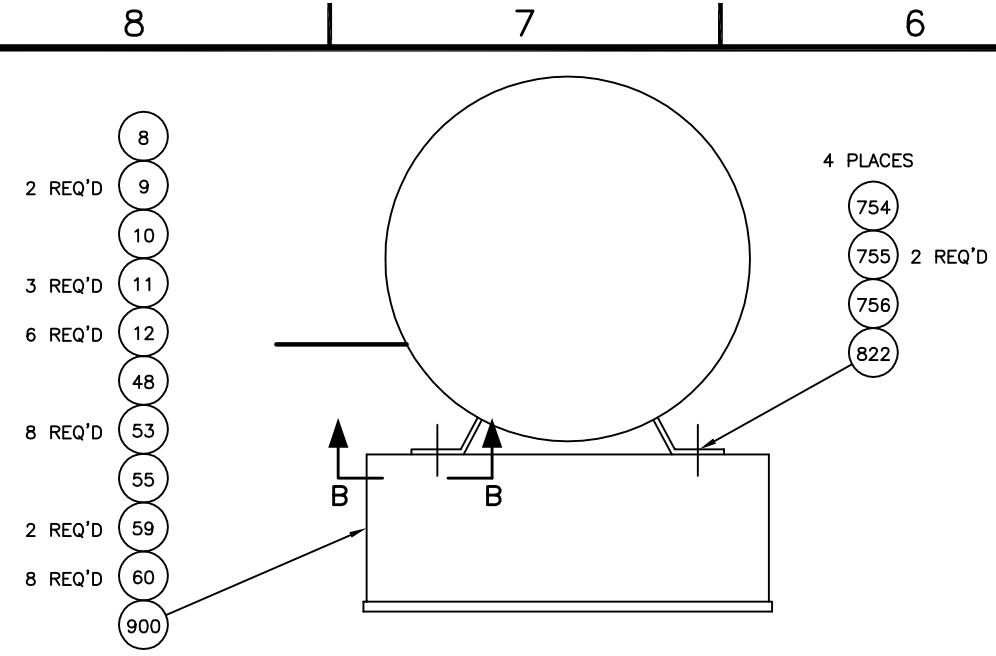

SECTION A-A

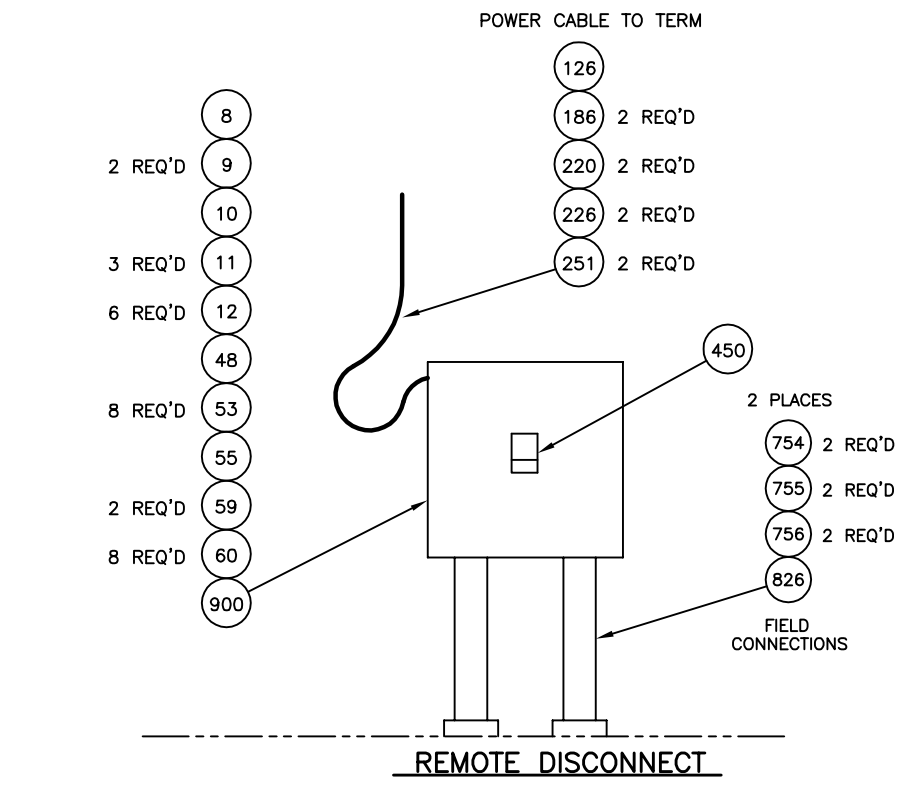

REMOTE DISCONNECT

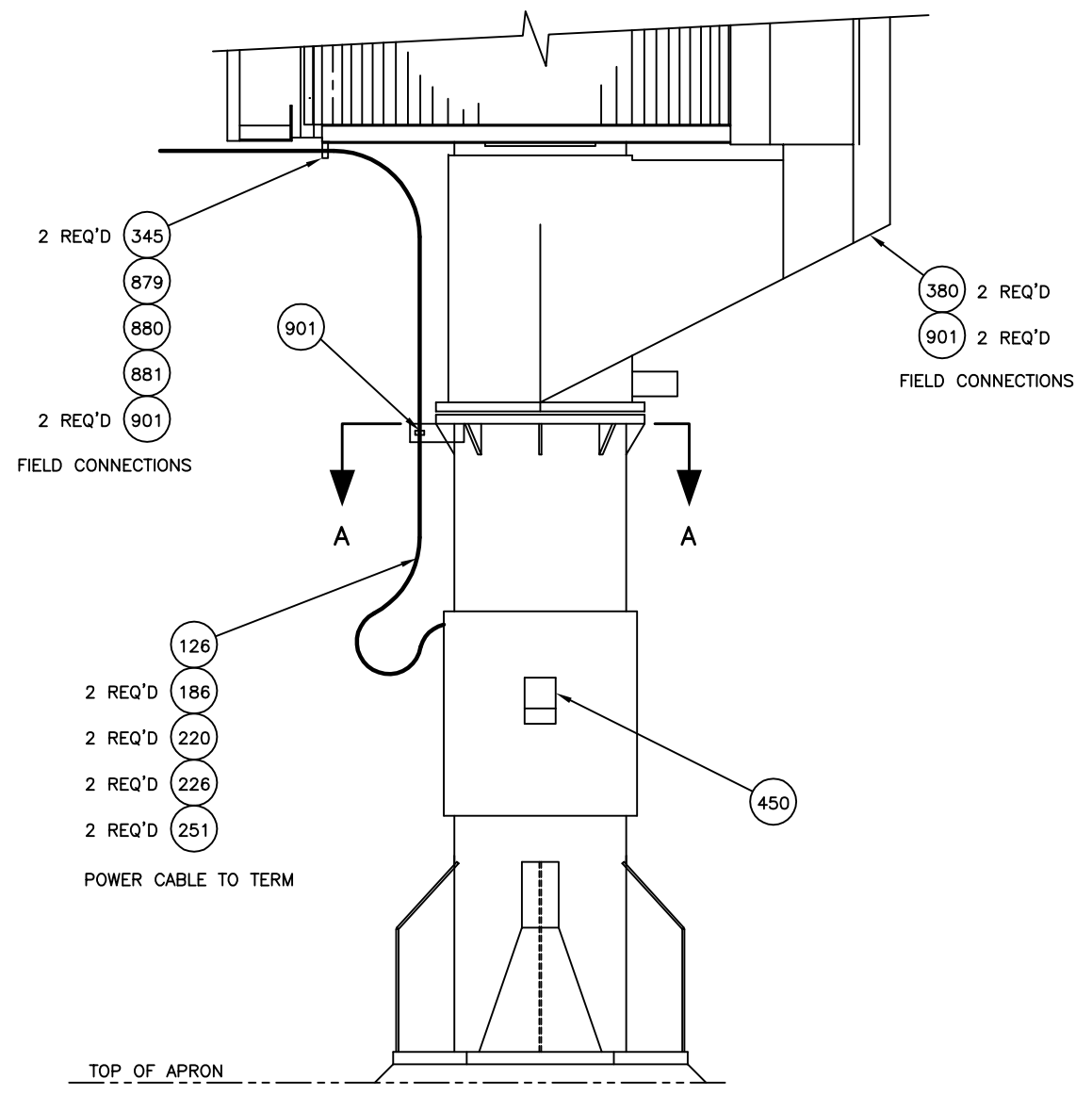

R.S. ELEVATION

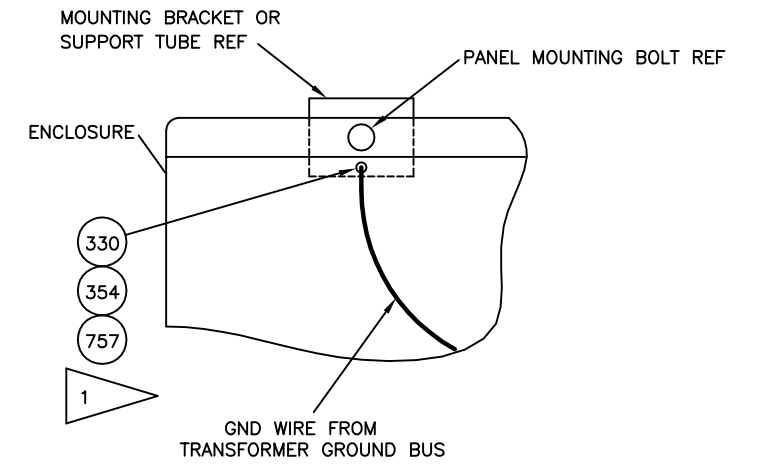

SECTION B-B

- BOM 3702276 POWER CABLE TO TERM (1/0GA) 55'
- BOM 3716353 POWER CABLE TO TERM (2GA) 55'
- BOM 3702274 POWER CABLE TO TERM (6GA) 55'
- BOM 3708659 POWER CABLE TO TERM (250MCM) 35'
- BOM 3709189 POWER CABLE TO TERM (4/0GA) 35'
- BOM 3702322 POWER CABLE TO TERM (3/0GA) 35'
- BOM 3719410 POWER CABLE TO TERM (2/0GA) 35'
- BOM 3702272 POWER CABLE TO TERM (1/0GA) 35'
- BOM 3721260 POWER CABLE TO TERM (4GA) 35'
- BOM 3716501 POWER CABLE TO TERM (2GA) 35'
- BOM 3702270 POWER CABLE TO TERM (6GA) 35'

- BOM 2954784.05 FIELD PARTS (REMOTE DISC)
- BOM 2954784.02 FIELD PARTS (STRAPS)

- BOM 3659299 POWER DIST BLOCK (310A)
- BOM 3659268 POWER DIST BLOCK (175A)
- BOM 3654401 CIRCUIT BRKR 350A 3P (PCA)
- BOM 3659266 CIRCUIT BRKR 300A 3P (PCA)
- BOM 3658343 CIRCUIT BRKR 250A 3P (PCA)
- BOM 3658342 CIRCUIT BRKR 225A 3P (PCA)
- BOM 3659265 CIRCUIT BRKR 175A 3P (PCA)
- BOM 3658674 CIRCUIT BRKR 125A 3P (PCA)
- BOM 3659264 CIRCUIT BRKR 125-250A 3P (400HZ)

- BOM 2954784.06 480V 100A (REMOTE DISC)
- BOM 2954784.04 480V 60A (REMOTE DISC)
- BOM 2954784.08 480V W/O CKT BRKR
- BOM 2954784.07 480V 60A 316 SST ENCL
- BOM 2954784.13 480V 70A (BRIDGE)
- BOM 2954784.03 480V 100A (BRIDGE)
- BOM 2954784.01 480V 60A (BRIDGE)

4. PAGE 2 PERTAINS TO ALL POWER FROM THE TERMINAL THAT REQUIRE CONDUIT/WIRE.

3 REQUIRED WITH 400HZ AND/OR PCA.

2. SEE ELECTRICAL JOB RELEASE E.O. FOR EXTRA PARTS TO BE USED.

1 AFTER MOUNTING POWER DISTRIBUTION PANEL TO ROTUNDA, MATCH DRILL & TAP HOLE FOR A #1/4-28 SCREW THRU BACK OF PANEL INTO ROTUNDA MOUNTING BRACKET APPROXIMATELY AS SHOWN.

NOTES: UNLESS OTHERWISE SPECIFIED

This drawing and any associated information or amendments are proprietary and confidential to Jetway. The drawing and information may only be used for the specific contract under which it is delivered and only by the purchaser. Acceptance of the drawing and information constitutes agreement not to reproduce it in whole or in part and not to disclose it to any other party and not use it for any purpose beyond the limited license granted herein without prior written consent.

JBT AeroTech
Jetway® Systems

DO NOT SCALE DRAWING
DRAWING SIZE B

THIRD ANGLE PROJECTION

Limits on Dimensions Unless Otherwise Specified	
.0	± .1 Angular ± 0° 30'
.00	± .03 Fractional ± 1/16
.000	± .010 XX SAE 846.1
Break Sharp Edges .010 Min. R.	
Drn.	LR 12-23-03
Redrn.	JBB 10-29-12
Appd.	MDF 10-29-12

Title		Part Number		Rev.
ROTUNDA ELECTRICAL ASSEMBLY		2954784		J
Scale:	NTS	Code:	54077	Sheet 1 OF 2

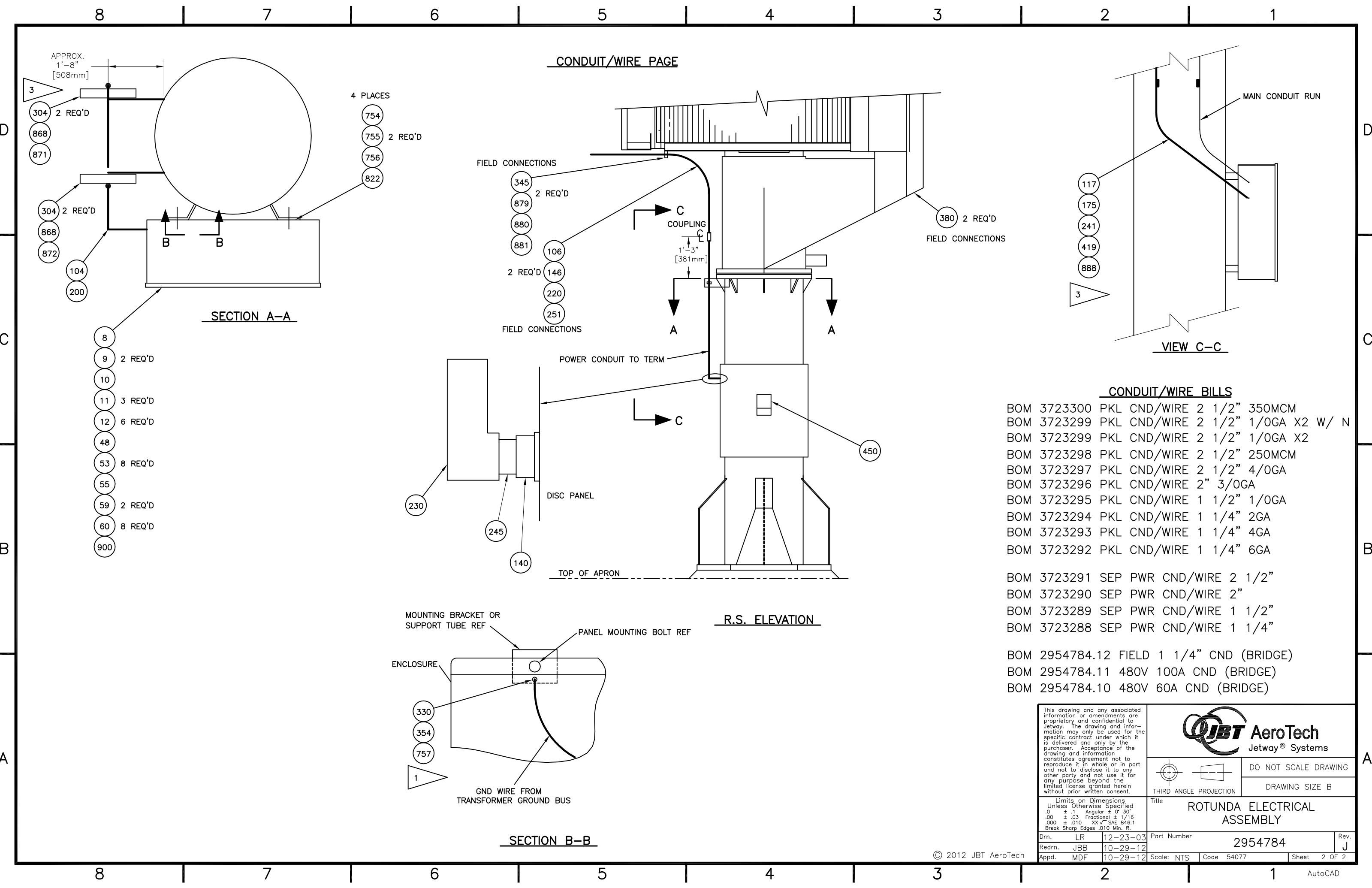

CONDUIT/WIRE PAGE

FIELD CONNECTIONS

- 304 2 REQ'D
- 868
- 871
- 754
- 755 2 REQ'D
- 756
- 822
- 345 2 REQ'D
- 879
- 880
- 881
- 106
- 146 2 REQ'D
- 220
- 251

380 2 REQ'D
FIELD CONNECTIONS

- 117
- 175
- 241
- 419
- 888

CONDUIT/WIRE BILLS

BOM	3723300	PKL	CND/WIRE	2	1/2"	350MCM
BOM	3723299	PKL	CND/WIRE	2	1/2"	1/0GA X2 W/ N
BOM	3723299	PKL	CND/WIRE	2	1/2"	1/0GA X2
BOM	3723298	PKL	CND/WIRE	2	1/2"	250MCM
BOM	3723297	PKL	CND/WIRE	2	1/2"	4/0GA
BOM	3723296	PKL	CND/WIRE	2"	3/0GA	
BOM	3723295	PKL	CND/WIRE	1	1/2"	1/0GA
BOM	3723294	PKL	CND/WIRE	1	1/4"	2GA
BOM	3723293	PKL	CND/WIRE	1	1/4"	4GA
BOM	3723292	PKL	CND/WIRE	1	1/4"	6GA
BOM	3723291	SEP	PWR CND/WIRE	2	1/2"	
BOM	3723290	SEP	PWR CND/WIRE	2"		
BOM	3723289	SEP	PWR CND/WIRE	1	1/2"	
BOM	3723288	SEP	PWR CND/WIRE	1	1/4"	
BOM	2954784.12	FIELD	1 1/4" CND (BRIDGE)			
BOM	2954784.11	480V 100A CND (BRIDGE)				
BOM	2954784.10	480V 60A CND (BRIDGE)				

<p>This drawing and any associated information or amendments are proprietary and confidential to Jetway. The drawing and information may only be used for the specific contract under which it is delivered and only by the purchaser. Acceptance of the drawing and information constitutes agreement not to reproduce it in whole or in part and not to disclose it to any other party and not use it for any purpose beyond the limited license granted herein without prior written consent.</p>		<p>JBT AeroTech Jetway® Systems</p>	
<p>Limits on Dimensions Unless Otherwise Specified .0 ± .1 Angular ± 0° 30' .00 ± .03 Fractional ± 1/16 .000 ± .010 XX SAE 846.1 Break Sharp Edges .010 Min. R.</p>		<p>DO NOT SCALE DRAWING DRAWING SIZE B</p>	
<p>THIRD ANGLE PROJECTION</p>		<p>Title ROTUNDA ELECTRICAL ASSEMBLY</p>	
<p>Drn. LR 12-23-03</p>	<p>Part Number 2954784</p>	<p>Rev. J</p>	<p>Sheet 2 OF 2</p>
<p>Redrn. JBB 10-29-12</p>	<p>Scale: NTS</p>	<p>Code 54077</p>	<p>AutoCAD</p>
<p>Appd. MDF 10-29-12</p>	<p>© 2012 JBT AeroTech</p>		

SECTION A-A

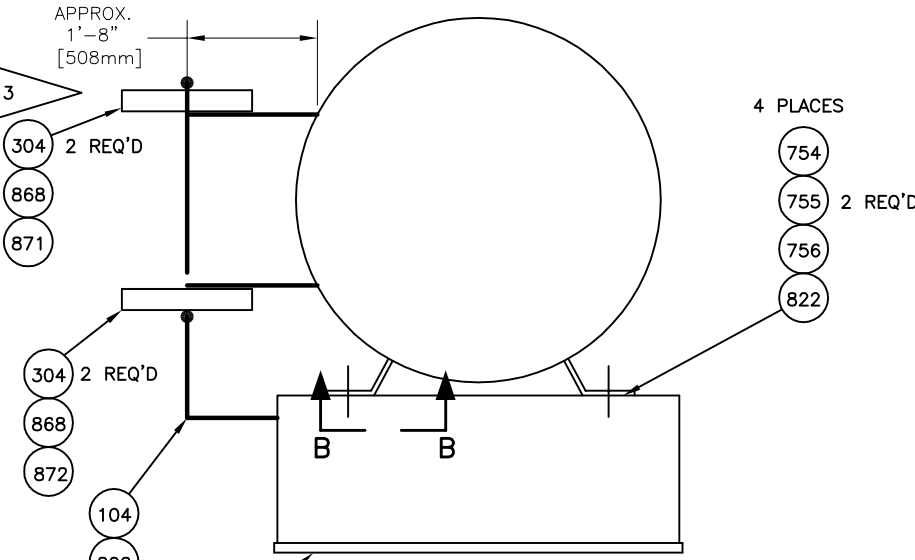

- 8
- 9 2 REQ'D
- 10
- 11 3 REQ'D
- 12 6 REQ'D
- 48
- 53 8 REQ'D
- 55
- 59 2 REQ'D
- 60 8 REQ'D
- 900

R.S. ELEVATION

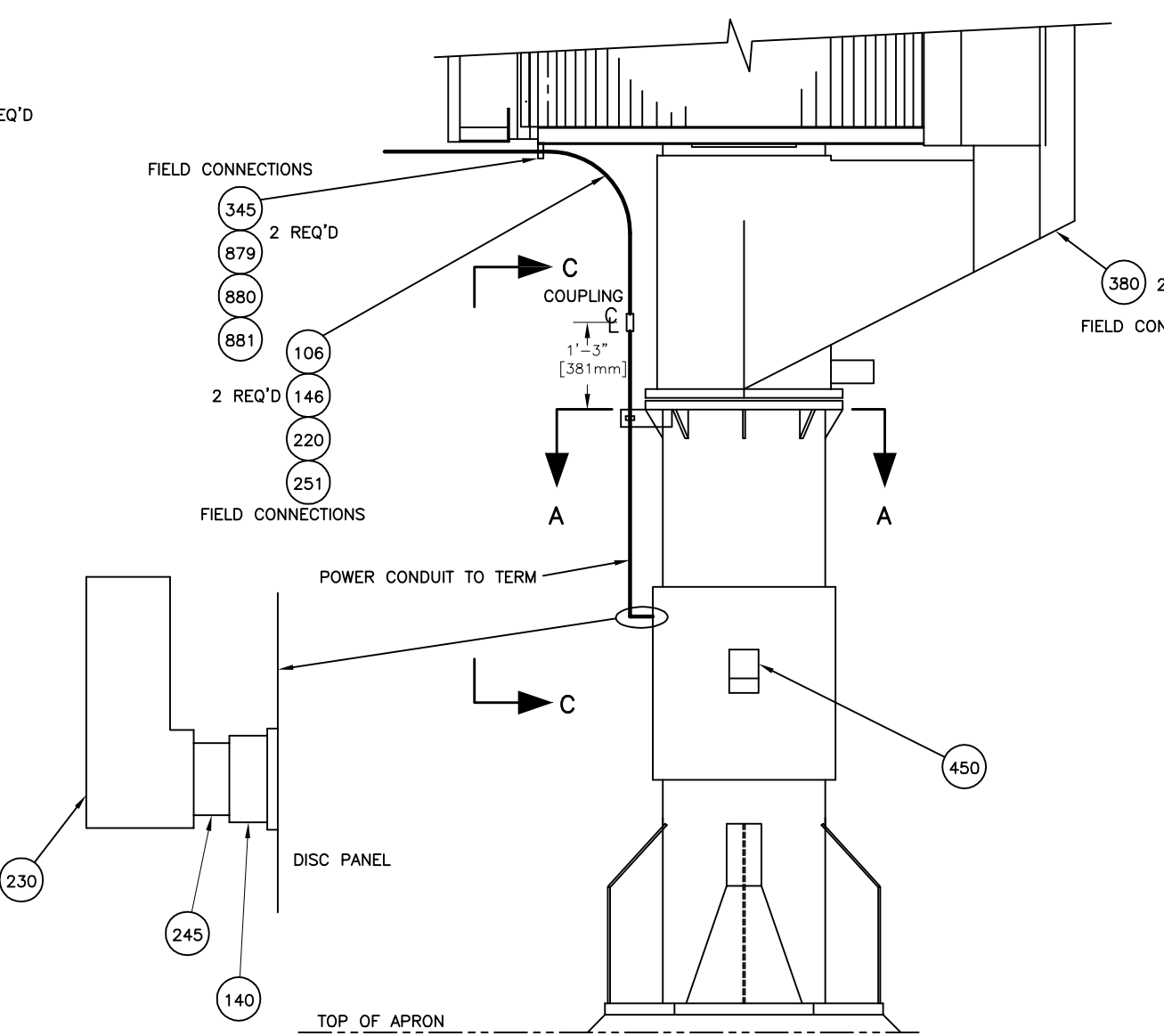

VIEW C-C

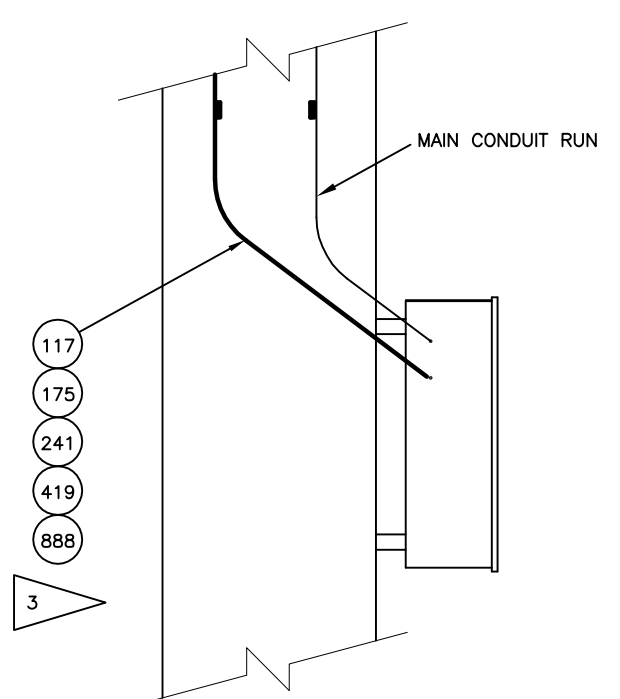

SECTION B-B

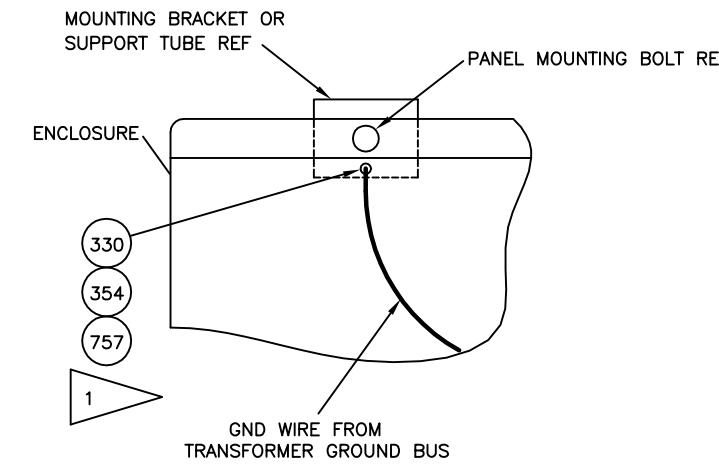

8 7 6 5 4 3 2 1

NOTES:

REVISION HISTORY						
SHEET	ZONE	REV	DESCRIPTION	ECO NO.	DATE	APPROVED
-	-	A	PRODUCTION RELEASE	N/A	06-11-14	RH

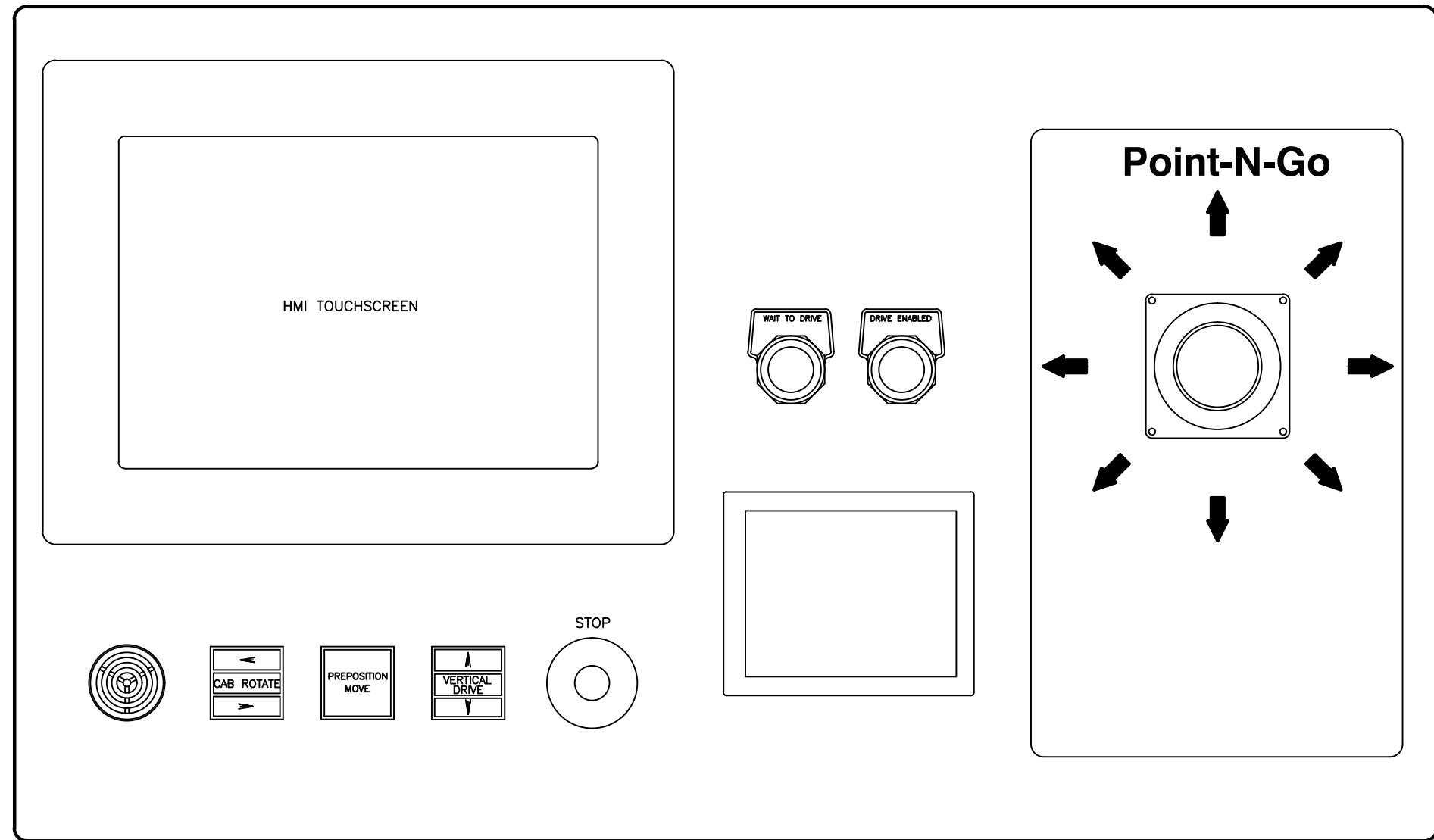

D
C
B
A

D
C
B
A

8 7 6 5 4 3 2 1

UNLESS OTHERWISE SPECIFIED ANG ±1° FRACTIONAL ±1/16 2 PL ±.06 3 PL ±.030 HOLES & SLOTS ±.015 MM 0 PL ±1.5 1 PL ±.75 INTERPRET DIM AND TOL PER ASME Y14.5-2009	DRW RH CHD JRR APD -	DATE 06-11-14 DATE 06-11-14 DATE -	Jetway® Systems Ogden, UT, U.S.A.	TITLE FACEPLATE VISUAL AID DENVER	
	THIRD ANGLE PROJECTION 	THIS DOCUMENT CONTAINS INFORMATION THAT IS PROPRIETARY AND CONFIDENTIAL TO JOHN BEAN TECHNOLOGIES CORPORATION AND ITS AFFILIATES, AND MAY NOT BE PUBLICLY DISCLOSED WITHOUT THE EXPRESS WRITTEN PERMISSION OF JOHN BEAN TECHNOLOGIES CORPORATION. UNDER ANY U.S. GOVERNMENT PRIME CONTRACT THIS INFORMATION SHALL BE CONSIDERED TO BE "LIMITED RIGHTS DATA". © 2014 JBT AeroTech.		SIZE D CAGE CODE 54077 SCALE: 1/1	DWG NO. 2962655 WEIGHT: LB: - KG: - SHEET 1 OF 1

1 AUTOCAD

SCALE:	1:NTS	SHEET	1
RQ	N/A	REV.	A
DRN.	M.MOSS		28 FEB 2009
REV.	J.OGDEN		16 DEC 2009

PLAN

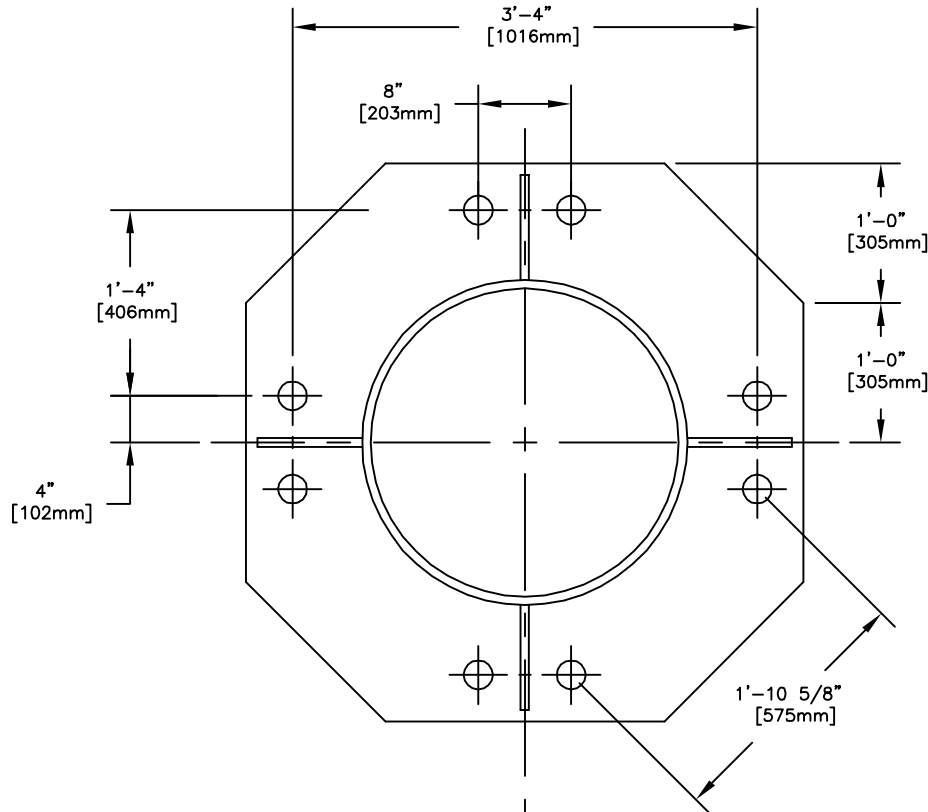

ELEVATION

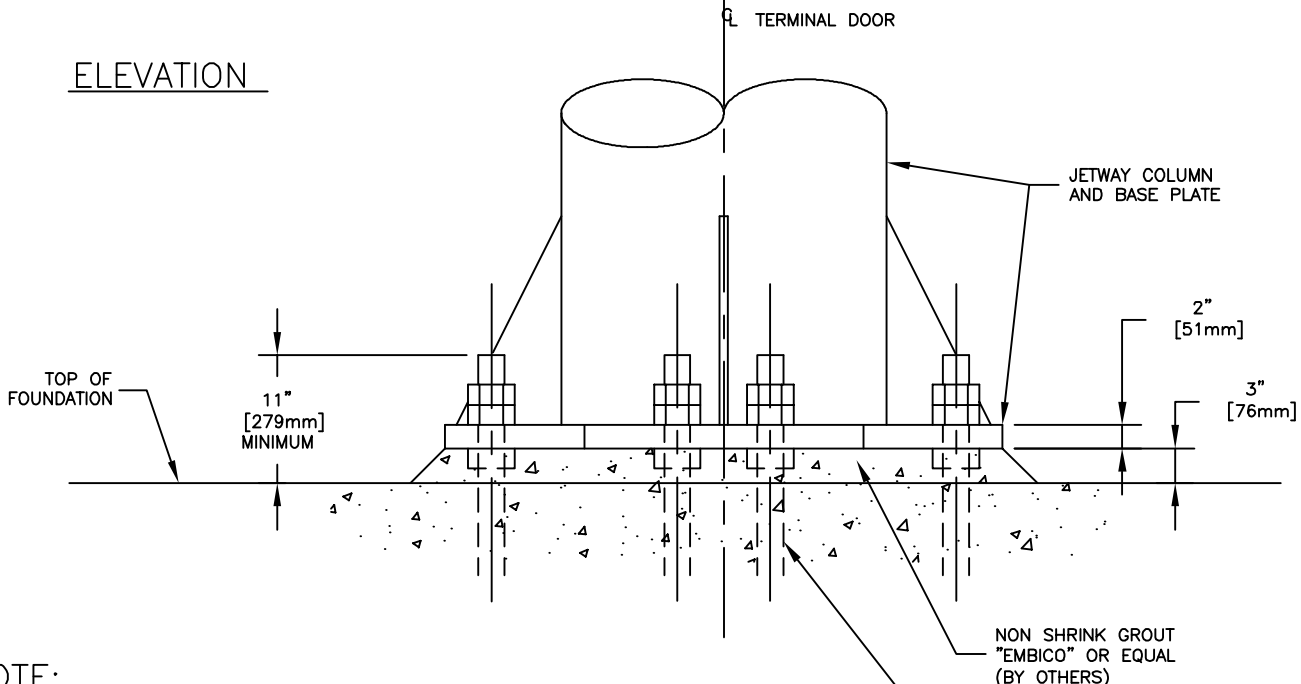

NOTE:

1. ANCHOR BOLTS DESIGNED FOR MILD STEEL (A36 OR A307). HIGH STRENGTH ANCHOR BOLTS ARE DISCOURAGED DUE TO BRITTLENESS

2. ANCHOR BOLTS MUST HAVE A MINIMUM 11" [279mm] PROJECTION ABOVE THE FINISHED CONCRETE FOUNDATION SURFACE. THE FULL PROJECTION OF THE ANCHOR BOLT MUST BE THREADED.

(8) 2 1/4" [60mm] DIA ANCHOR BOLTS (PER COLUMN) W/ 3 HEAVY HEX NUTS PER BOLT (BY OTHERS) SEE FOUNDATION ENGINEER FOR ANCHOR BOLT LENGTH AND ANCHORAGE

City & County of Denver
Denver Int'l Airport
Denver, CO

ID	Task Name	Duration	Start	Finish	2015											
					Jun	Jul	Aug	Sep	Oct	Nov	Dec	Jan	Feb	Mar	Apr	May
1	Proposals Due	1 day	Wed 6/17/15	Wed 6/17/15	Proposals Due											
2	Notice of Award	16 days	Thu 6/18/15	Fri 7/10/15	Notice of Award											
3	Prepare Internal Job Order	1 day	Mon 7/13/15	Mon 7/13/15	Prepare Internal Job Order											
4	ENGINEERING	45 days	Mon 7/13/15	Mon 9/14/15	ENGINEERING											
5	Engineering	20 days	Tue 7/14/15	Mon 8/10/15	Engineering											
6	Prepare Submittals	20 days	Tue 7/14/15	Mon 8/10/15	Prepare Submittals											
7	Submittals Due	30 days	Mon 7/13/15	Fri 8/21/15	◆ 8/21											
8	Engineering Release to Manufacturing	0 days	Fri 8/21/15	Fri 8/21/15	◆ Engineering Release to Manufacturing											
9	Permits Due	15 days	Mon 8/24/15	Mon 9/14/15	◆ 9/14											
10	MANUFACTURE EQUIPMENT	55 days	Mon 7/13/15	Mon 9/28/15	MANUFACTURE EQUIPMENT											
11	Procure Material	30 days	Mon 7/13/15	Fri 8/21/15	Procure Material											
12	Manufacture Passenger Boarding Bridge # 1	20 days	Mon 8/24/15	Mon 9/21/15	Manufacture Passenger Boarding Bridge # 1											
13	Manufacture Passenger Boarding Bridge # 2	20 days	Tue 8/25/15	Tue 9/22/15	Manufacture Passenger Boarding Bridge # 2											
14	Manufacture Passenger Boarding Bridge # 3	20 days	Wed 8/26/15	Wed 9/23/15	Manufacture Passenger Boarding Bridge # 3											
15	Manufacture Passenger Boarding Bridge # 4	20 days	Thu 8/27/15	Thu 9/24/15	Manufacture Passenger Boarding Bridge # 4											
16	Manufacture Passenger Boarding Bridge # 5	20 days	Fri 8/28/15	Fri 9/25/15	Manufacture Passenger Boarding Bridge # 5											
17	Manufacture Passenger Boarding Bridge # 6	20 days	Mon 8/31/15	Mon 9/28/15	Manufacture Passenger Boarding Bridge # 6											
18	SHIP EQUIPMENT	69 days	Mon 10/5/15	Tue 1/12/16	SHIP EQUIPMENT											
19	Ship PBB # 1	2 days	Mon 10/5/15	Tue 10/6/15	Ship PBB # 1											
20	Ship PBB # 2	2 days	Mon 10/19/15	Tue 10/20/15	Ship PBB # 2											
21	Ship PBB # 3	2 days	Mon 11/2/15	Tue 11/3/15	Ship PBB # 3											
22	Ship PBB # 4	2 days	Mon 11/30/15	Tue 12/1/15	Ship PBB # 4											
23	Ship PBB # 5	2 days	Mon 12/14/15	Tue 12/15/15	Ship PBB # 5											
24	Ship PBB # 6	2 days	Mon 1/11/16	Tue 1/12/16	Ship PBB # 6											
25	INSTALL EQUIPMENT	77 days	Mon 10/5/15	Fri 1/22/16	INSTALL EQUIPMENT											
26	Install PBB # 1	10 days	Mon 10/5/15	Fri 10/16/15	Install PBB # 1											
27	Prep Equipment for Take Down	1 day	Mon 10/5/15	Mon 10/5/15	Prep Equipment for Take Down											
28	Take Down Existing Equipment	1 day	Tue 10/6/15	Tue 10/6/15	Take Down Existing Equipment											
29	Install New Bridge	6 days	Wed 10/7/15	Wed 10/14/15	Install New Bridge											
30	Commissioning	1 day	Thu 10/15/15	Thu 10/15/15	Commissioning											
31	Hand Over to DIA	1 day	Fri 10/16/15	Fri 10/16/15	Hand Over to DIA											
32	Install PBB # 2	10 days	Mon 10/19/15	Fri 10/30/15	Install PBB # 2											
33	Prep Equipment for Take Down	1 day	Mon 10/19/15	Mon 10/19/15	Prep Equipment for Take Down											
34	Take Down Existing Equipment	1 day	Tue 10/20/15	Tue 10/20/15	Take Down Existing Equipment											
35	Install New Bridge	6 days	Wed 10/21/15	Wed 10/28/15	Install New Bridge											
36	Commissioning	1 day	Thu 10/29/15	Thu 10/29/15	Commissioning											
37	Hand Over to DIA	1 day	Fri 10/30/15	Fri 10/30/15	Hand Over to DIA											

Date: Tue 6/16/15

Task
Split



Milestone
Summary



Project Summary



City & County of Denver
 Denver Int'l Airport
 Denver, CO

ID	Task Name	Duration	Start	Finish	2015																	
					Jun	Jul	Aug	Sep	Oct	Nov	Dec	Jan	Feb	Mar	Apr	May						
38	Install PBB # 3	10 days	Mon 11/2/15	Fri 11/13/15																		
39	Prep Equipment for Take Down	1 day	Mon 11/2/15	Mon 11/2/15																		
40	Take Down Existing Equipment	1 day	Tue 11/3/15	Tue 11/3/15																		
41	Install New Bridge	6 days	Wed 11/4/15	Wed 11/11/15																		
42	Commissioning	1 day	Thu 11/12/15	Thu 11/12/15																		
43	Hand Over to DIA	1 day	Fri 11/13/15	Fri 11/13/15																		
44	Install PBB # 4	10 days	Mon 11/30/15	Fri 12/11/15																		
45	Prep Equipment for Take Down	1 day	Mon 11/30/15	Mon 11/30/15																		
46	Take Down Existing Equipment	1 day	Tue 12/1/15	Tue 12/1/15																		
47	Install New Bridge	6 days	Wed 12/2/15	Wed 12/9/15																		
48	Commissioning	1 day	Thu 12/10/15	Thu 12/10/15																		
49	Hand Over to DIA	1 day	Fri 12/11/15	Fri 12/11/15																		
50	Install PBB # 5	10 days	Mon 12/14/15	Mon 12/28/15																		
51	Prep Equipment for Take Down	1 day	Mon 12/14/15	Mon 12/14/15																		
52	Take Down Existing Equipment	1 day	Tue 12/15/15	Tue 12/15/15																		
53	Install New Bridge	6 days	Wed 12/16/15	Wed 12/23/15																		
54	Commissioning	1 day	Thu 12/24/15	Thu 12/24/15																		
55	Hand Over to DIA	1 day	Mon 12/28/15	Mon 12/28/15																		
56	Install PBB # 6	10 days	Mon 1/11/16	Fri 1/22/16																		
57	Prep Equipment for Take Down	1 day	Mon 1/11/16	Mon 1/11/16																		
58	Take Down Existing Equipment	1 day	Tue 1/12/16	Tue 1/12/16																		
59	Install New Bridge	6 days	Wed 1/13/16	Wed 1/20/16																		
60	Commissioning	1 day	Thu 1/21/16	Thu 1/21/16																		
61	Hand Over to DIA	1 day	Fri 1/22/16	Fri 1/22/16																		
62	Project Completion	0 days	Fri 1/22/16	Fri 1/22/16																		

- Install PBB # 3
 - Prep Equipment for Take Down
 - Take Down Existing Equipment
 - Install New Bridge
 - Commissioning
 - Hand Over to DIA
- Install PBB # 4
 - Prep Equipment for Take Down
 - Take Down Existing Equipment
 - Install New Bridge
 - Commissioning
 - Hand Over to DIA
- Install PBB # 5
 - Prep Equipment for Take Down
 - Take Down Existing Equipment
 - Install New Bridge
 - Commissioning
 - Hand Over to DIA
- Install PBB # 6
 - Prep Equipment for Take Down
 - Take Down Existing Equipment
 - Install New Bridge
 - Commissioning
 - Hand Over to DIA
 - Project Completion

Date: Tue 6/16/15

Task
 Split



Milestone
 Summary



Project Summary





3. Denver International Airport currently has a Wi-Fi network to communication with some existing PLBs. Explain, in detail, how the proposed bridges can interface with the existing system and what information can be communicated to a central maintenance control.

JBT understands that DIA has a wireless network used to monitor the Passenger Boarding Bridges. Our proposal included the preparation of the PBB's to be integrated onto this network. What our proposal does not include is the programming; site licenses and the like to add the PBB onto the SCADA system.

The PBB will be delivered with a WiFi antenna and WiFi/Ethernet radio. The antenna will be placed line of sight to the DIA WiFi access point. This will be either at the cab end or the rotunda end of the PBB. The radio will be located in the operator's console of the bridge. See attached drawings and photos for an example.

The PBB is controlled by an industrial Windows based PC, therefore, each bridge can be pre-address with the desired IP address prior to leaving the factory if DIA will provide the desired IP address. Further the Lantronix Ethernet radio can be addressed as desired.

The WiFi access will transmit information to the primary SCADA/monitoring system to give visibility to current status of the PBB and the solid state frequency converter.

RMS System Messages Available To Display

- Autolevel Failure -- reset autolevel. CALL MAINTENANCE.
- Bridge Extend Ultimate reached. Retract Bridge. CALL MAINTENANCE.
- Bridge Retract Ultimate reached. Extend Bridge. CALL MAINTENANCE.
- Vertical Up Ultimate limit. CALL MAINTENANCE.
- Vertical Down Ultimate limit. CALL MAINTENANCE.
- Left or Right Vertical Fault. Vertical motion disabled. CALL MAINTENANCE.
- Left Vertical Motor Overload. CALL MAINTENANCE.
- Right Vertical Motor Overload. CALL MAINTENANCE.
- Main Contactor Weld Fault. CALL MAINTENANCE.
- Vertical Up Contactor Weld Fault. CALL MAINTENANCE.
- Cab Left Ultimate. CALL MAINTENANCE.
- Cab Right Ultimate. CALL MAINTENANCE.

- Autolevel wheel timeout. CALL MAINTENANCE.
- Vertical Down Contactor Weld Fault
- Cab left contactor weld fault.
- Cab right contactor weld fault.
- Cab Floor Fault - Level Floor Manually
- Swing Ultimate Activated...BYPASS required. Call Maintenance.
- Autolevel Watchdog Timer Timed Out. Reset Autolevel. Call Maintenance.
- 400 Hz Fault -- Call Maintenance.
- PC Air Fault -- Call Maintenance
- Inverter Fault -- Call Maintenance.
- Safety Shoe NOT connected. Plug in safety shoe.
- Safety Shoe activated during autolevel.
- Cab Potentiometer failure. Contact Maintenance.
- Emergency Stop button pressed. All motion disabled.
- Collision Warning!!! Drive Bridge left.
- Collision Warning!! Drive Bridge right.
- Collision Avoidance Inoperative!!!
- Vertical Up Limit - Drive bridge down
- Vertical Down Limit - Drive bridge up
- Extend Limit - Retract bridge
- Retract Limit - Extend bridge
- Limits disabled, drive with caution
- Cab right limit - rotate cab left
- Cab Left Limit - rotate cab right
- Swing Right Limit - swing bridge left
- Swing Left Limit - swing bridge right
- Slope up limit - Extend bridge or drive bridge down.
- Slope Down limit - Extend bridge or drive bridge up.
- Floor Tip Contacted - Drive bridge up or back.
- CE Floor right tape switch activated. Rotate cab right.
- CE Floor left tape switch activated. Rotate Cab left.
- Spacer Left Switch activated... Forward motion and Cab Right motion disabled.
- Spacer Right switch activated... Forward motion and Cab Left motion disabled.
- Terminal Door Interlock Active -- Horizontal motion disabled.
- Hoist down -- Horizontal motion disabled.
- PCAir running -- Horizontal motion disabled.



-
- Pre-position complete... Finish docking manually
 - 400 Hz on -- Horizontal motion disabled.
 - Wing Root Contact
 - Hoist #1 Down -- Horizontal Motion Disabled
 - Hoist #2 Down -- Horizontal Motion Disabled
 - 28VDC Interlock... Horizontal Motion disabled.
 - Main Contactor not energized... Check interlocks.
 - ACF Fault... Level ACF Floor manually.
 - Pre-position done... Finish docking manually
 - Bridge in slowdown.
 - Main Contactor has dropped out. Please log off to reset, then log in.
 - Wing Root Switch activated. All Bridge motion disabled except Vertical Up.
 - Bridge in Swing Left Limit Approach area.
 - Bridge in Swing Right Limit Approach area.
 - Canopies down.... Horizontal motion disabled.
 - Bumper Limit(s) Active - Fwd. Horiz. motion Disabled. Press Spacer Bypass.
 - Safety Shoe NOT connected.
 - Safety Hoop contacted -- Horiz. motion disabled.
 - Cab Hoist Down -- Horizontal motion disabled.
 - Tunnel Hoist Down -- Horizontal motion disabled.
 - Bridge in Operate Mode
 - Bridge in Autolevel Mode... Press Autolevel Button to return to Operate Mode
 - Bridge in Pre-Position Mode
 - Autolevel Mode
 - Performing Test Nod...Please Wait
 - IR Sensor Active
 - Canopies not fully retracted. Forward motion disabled.
 - Autolevel is not in neutral position.. Reset Autolevel

PBB Horizontal Drive VFD Information-Denver Specific

- VFD_TripFactor
- VFD_OutVolts
- VFD_OutCurrent
- VFD_StatusA
- VFD_StatusB
- VFD_StatusC
- VFD_Frequency



- VFD_AccRunTime
- VFD_PowerOnTime
- VFD_AccCount AT

Monitoring of the INET 400 Hz Solid State Frequency Converter-Denver Specific Status Messages

- On #1 Status
- On #2 Status
- E&F #1
- E&F #2
- Cable Fault #1
- Cable Fault #2
- Summary Fault
- Over Voltage
- Under Voltage



4. Describe experience with Small, Minority, and Women Owned Business Entities. Provide with this description names and contact information of individuals affected by this relationship for DEN to possibly contact.

JBT AeroTech, Jetway Systems® is committed to the participation of qualified Small, Minority, and Women owned businesses, or with designated subcontractors, in its projects across the country. That commitment goes beyond compliance with any particular program requirement. It recognizes that its specialty manufactured equipment makes up nearly 90% of the value of a contract because the S/M/WBE program mandated for a given project is limited to those companies certified by the Customer at the time of a proposal opening. There is limited opportunity for satisfying the S/M/WBE goals for contracts on the manufactured equipment. Nonetheless, Jetway believes that it is important that the Customer understand it has established a number of significant supplier contracts with S/M/WBE Business Enterprises. These business enterprises currently supply between 7% and 19% of the purchased parts used in the Jetway passenger boarding bridges (depending on bridge configuration).

Efforts are also made to encourage the hiring of women and minorities as part of the workforce at the Jetway facility in Ogden, Utah. Approximately 28% of the workforce is composed of women and minorities.

Historical Record in Meeting DBE Good Faith Efforts and Goals

Jetway is regularly asked to participate in S/M/WBE programs at airports across the country. Jetway works hard to be fully compliant with the good faith effort and outreach programs wherever it is bidding. We know of no instance where Jetway has been rejected for lack of DBE participation or failure to meet a good faith effort. On some of our most recent projects, Jetway has obtained MBE/WBE/DBE content of 3.7% for a Sioux Falls, South Dakota project, 5.4% for a Columbia, South Carolina project, 8.9% for a Raleigh-Durham project, 8.4% for a Detroit, Michigan project, and 9.9% for a Dallas/Fort Worth, Texas project.

Achieving S/M/WBE goals and meeting good faith efforts require significant effort by Jetway due to the fact that most of the contract value is found in the manufactured product. An ability to change the S/M/WBE content in the manufactured product is, of course, quite limited on a project basis. For example, typically about 89% of Jetway's bid is within its scope of work as an OEM. Jetway is an original manufacture of boarding bridges, 400 Hz ground power systems, pre-conditioned air units, and potable



water cabinets. Jetway is the only manufacturer in the United States with this broad umbrella of products.

To remove old bridges and install new bridges, Jetway has certified a handful of primary subcontractors. These subcontractors are experienced specialists in the takedown, removal, and erection of passenger boarding bridges and other gate-related equipment. Because of their repeated role in the passenger bridge projects on which Jetway bids, these subcontractors participate in Jetway's efforts to obtain the participation of MBE/WBE/DBE firms. Like Jetway, they too have a superior record at meeting DBE goals and effecting approved good faith efforts. It is something that the primary subcontractors take seriously.

Effective Outreach Efforts

In the spirit of a true outreach program, Jetway and its primary subcontractors go to great lengths to actually contact individuals at candidate DBE businesses and solicit from them quotes for the referenced projects. Rather than using mass mailings or similar approaches, a telephone outreach program is used to make contact with the appropriate individuals in the DBE organization and solicit their participation. The requests for expressions of interest are made person-to-person. It is highly unlikely that some of these DBE participants would have known about the projects except through the outreach efforts of Jetway and its subcontractors.

Overview of the Good Faith Outreach Effort

Jetway typically works with primary subcontractors on its boarding bridge projects. The subcontractors are specialists in the takedown, removal, and installation of boarding bridges and other gate-related airport equipment. Their specialized knowledge of the products and practices often encountered at airports ensures that the project runs smoothly and is brought to completion in a timely and cost effective manner.

Jetway is generally responsible for the supply of the manufactured goods, transport of the equipment to site, the commercial aspects of the project, and, of course, ultimate responsibility for overall compliance. The primary subcontractors in turn are responsible for the civil and site works which typically comprises the demolition of the old bridges and the installation of new bridges. Each primary subcontractor approaches this work in a slightly different manner, including identifying the types of subcontractors that it will use. Normally, the primary subcontractors will solicit work from lower tier subcontractors for work not normally handled by their full-time crews.



As a result of this general division of labor, Jetway and the primary subcontractors are both involved in the S/M/WBE good faith, and outreach efforts. However, while under the general supervision of Jetway, each participant – Jetway and the subcontractors -- take a different role in seeing that an effective outreach program is followed.

In general, the good faith effort followed by Jetway and its primary subcontractors unfolds in three levels of outreach. These levels of outreach are explained below. The basic practice is to advertise, get DBE directories, conduct telephone surveys of DBE candidates listed in the directories, and follow up in writing any that express interest.



5. Explain the process for mitigating the used hydraulic oil during the replacement.

Preparation and Disposal

The Jetway passenger boarding bridges are electro-mechanical devices and therefore do not have fluids that need to be handled or disposed of. The Stearns bridges will have hydraulic fluid that will be captured and disposed of. DIA will be given the opportunity to re-use the fluid in existing bridges, if not JBT/Western will remove the fluids and take off site for disposal.

Hydraulic and Glycol Fluid Remediation Plan

Option 1 - DIA assists with pumping the fluids out and they capture in barrels for disposal or recycle.

Option 2 - Western Industrial Contractors has the capacity to pump, capture and remove from DIA to their "in house" recycle fluid containers and dispose by having Safety Klean pick it up from our shop when they pick up our disposal fluids. i.e. oil, fuel, chemical wash fluid, hydraulic fluids, and various grease.

PBB Disposal and Recycle Plan

Western Industrial Contractors has a working contract with IMI metals for the disposal of any of the PBB and Rotunda's. The recycle monies vary on market conditions. Any money gained from the sale/scraping of the bridge will be turned over to DIA.

The PBB and Rotunda from its current locations and transport to 88th Ave. The PBB will be unload in the boneyard so DIA can strip any equipment they feel necessary for spare parts. Western will unload the PBB in safe manner, crib off the ground 6" to 8" to clear bottom components to allow DIA to safely remove any equipment they want, however they also have to leave it in a safe condition for us to return and remove it in safe manner. We assume that the bridge will be left in a safe condition to allow transport to IMI.

Upon an agreed time by both DIA and Western we will return, re-pick, load and transport to the salvage yard –IMI's location.



We know from past experience that IMI can only accept one PBB and rotunda a week as their capacity is somewhat limited.

This letter is being issued to certify that (Western Industrial Contractors) has two (2) scenarios

1. DIA assists with pumping the fluids out and they capture in barrels for disposal or recycle. They have done this since we have been changing bridges.
2. Western has the capacity to pump, capture and remove from DIA to our "in house" (shop) recycle fluid containers and dispose by having Safety Klean pick it up from our shop when they pick up our disposal fluids. i.e. oil, fuel, chemical wash fluid, hydraulic fluids, and various grease.



6. Detail how warranty work is expected to be completed.
a. Is there an option to train DEN employees for warranty work and give a credit for the work completed?

Warranty

The warranty called for in the RFP is a one year parts and labor warranty. JBT will work with DIA to determine the best procedure for providing the highest quality of service. JBT is amenable to using DIA maintenance personnel for the warranty work. A procedure will be developed with DIA for authorization and charging of warranty work. Further JBT and DIA will establish reimbursable rates.

Should DIA elect not to participate in the warranty work, JBT will contract with Western Industrial Contractors to be the first responder to critical warranty issues. This will allow a response time of four (4) hours or less. JBT will then have the option of having Western Industrial complete the work or send in a JBT Field Engineer.

As mentioned above maintenance training was not specifically included in the project requirements. Should DIA elect to use a portion of the 16 Hours for maintenance training, that would be acceptable. Additional training can be purchased at \$1,500/day plus expenses.

Training

The RFP calls for 16 hours of operator training. We will divide the hours as determined by DIA to support the tenant airlines and user group. The RFP did not call for maintenance training. JBT does offer maintenance training and even a video tape of the training session for orientation and refresher training. This can be quoted separately if desired.

Operator training consists of high level orientation and introduction to the functions of the PBB. Specific operational criteria and procedures will be left to DIA and the specific airline users. The Trainer will refer to the operators section of Chapter 1 of the O&M Manual for general orientation. The actual training is hands on at the bridge so that the operators get a feel for the bridges they will be using.



CUSTOMER SERVICE PROCEDURES **DENVER INTERNATIONAL AIRPORT**

JBT AeroTech – Jetway Systems (Jetway) maintains 24 hour support for the passenger boarding bridges. The contact phone numbers and procedures are listed below.

Contact Procedure Summary

The first call should be made to Jetway. Jetway will then call out a first responder. To support the first responder effort Jetway will have on call purchase order with Western Industrial Contractors (WIC).

Procedure

Once a problem is identified a call should be placed to Jetway. Customer Service Hot Line number **800-827-4414**. This number is answered by the Customer Service group during normal business hours and by an Answering Service after hours.

Alternatively, should Jetway not be available and a bridge out of service situation exists, WIC can be contacted directly at **(303) 371-3714**. Please note that without proper authorization from Jetway, WIC and the Customer may be responsible for charges if the service call is found to be outside the scope of the warranty provisions.

- a. The Customer service hot line number is: 800 827-4414. This will go directly to the Customer Service group during business hours and will be answered by our Security Department or an answering service after hours. Or they can call:**

Direct Number 1-801-629-3444 Fax 1-801-629-3476

- b. Direct contact numbers for warranty/install replacement parts:**

- i. Scott Heywood - 801 629-3483 (office) 801 940-1805 (mobile). Email: scott.heywood@jbtc.com**
- ii. Cherie Young 801 629-3430. Email: cherie.young@jbtc.com**

iii. **Steve LaFevre – 801 629-3147 (office) 801 940-1826 (mobile). Email: steve.lefevre@jbt.com**

c. Direct contact numbers for Technical assistance:

i. **Scott Heywood - 801 629-3483 (office) 801 940-1805 (mobile). Email: scott.heywood@jbt.com**

ii. **Allen McKenzie - 801 629-3165 (office) 801 940-1797 (mobile). Email: allen.mckenzie@jbt.com**

iii. **Bill Long - 801 629-3420 (office) 801 940- 1820 (mobile). Email: bill.long@jbt.com**

iv. **Charlie Cole - 801-629-3127 (office) 801 940-1820 (mobile). Email: charlie.cole@jbt.com**

v. **Blaine Edwards – (mobile) 801 940-2091 blaine.edwards@jbt.com**



7. Detail the training included in the pricing, is this training ongoing? How many sessions are included in each bridge installation?

The RFP calls for 16 hours of operator training. We will divide the hours as determined by DIA to support the tenant airlines and user group. The RFP did not call for maintenance training. JBT does offer maintenance training and even a video tape of the training session for orientation and refresher training. This can be quoted separately if desired.

Operator training consists of high level orientation and introduction to the functions of the PBB. Specific operational criteria and procedures will be left to DIA and the specific airline users. The Trainer will refer to the operators section of Chapter 1 of the O&M Manual for general orientation. The actual training is hands on at the bridge so that the operators get a feel for the bridges they will be using.



9. Discuss your proposed product life cycle?

a. Specifically, what are the anticipated upgrade/refurbishment intervals for the products to remain viable?

b. What are the anticipated service discontinuation dates for the technologies included in the products proposed?

The Jetway product has been proven to be robust over time. In fact DEN has firsthand experience with several original Stapleton bridges still in operation at DEN today. These bridges were installed in approximately 1987. It is not uncommon for Jetway bridges to exceed 30 years of service.

JBT is committed to supporting the equipment with parts for a minimum of 10 years; however we are still supporting product that is well over 30 years old. With the largest installed base of any passenger boarding bridge manufacturer JBT take pride in our ability to service the product long after the design warranty has expired. We can never know when suppliers will obsolete or change parts, especially when it comes to electrical components, but we are committed to offering the Owner a replacement solution either through alternate sourcing or retrofit kits.

The Jetway bridge has only one component that has a scheduled inspect/replacement plan. The Ball Screw has a scheduled lubrication schedule per the maintenance schedule. The Maintenance Schedule calls for an inspection of the Ball Screw at 10 years after service. The attached pages from the O&M Manual briefly describe the procedures for the ball screw inspection. If the ball screw passes inspection it is recommended to be inspected every five (5) years after that.



Passenger Boarding Bridge Reliability and Performance Statement

The JBT AeroTech, Jetway Systems[®] [hereafter known as “Jetway”] passenger boarding bridge is the most widely used boarding bridge in the world. Over 8,800 Jetway bridges have been built and installed over the more than five decades of Jetway’s existence. Approximately 85% of these bridges are still on-site at airports in more than 40 countries across the globe.

Jetway has collected bridge maintenance and reliability data from a variety of airport locations in the United States, Asia, Europe and the Middle East as part of on-going maintenance contracts with a number of airport municipalities, and as part of its warranty records system. Jetway product designs (i.e. Apron Drive, TeleRadial and Pedestal bridges) share common components and construction methods (i.e. controls, motors, tires, etc.). To more accurately indicate the actual and predicted lifecycle of these common components, data is compiled from the most severe environments and applications.

Using this information, Jetway has collected a cross-section of data from bridges similar in design to those proposed for this project. **The primary source of data for this study are the maintenance records for the year 2002 from 47 specific boarding bridges installed in 2000 and currently in use at a major international airport.**

1. Life Cycle Cost Information:

Cost Parameters:

A description of relevant costing parameters, associated with the after-warranty period, is provided below for use in lifecycle cost determinations:

<u>Description</u>	<u>Findings</u>
Avg. Repair Man Hours	2 hours per bridge per year
Avg. Scheduled Maintenance	30 to 50 man hours per bridge per year in accordance with recommended PM schedules
Avg. Total Parts Cost	\$660 per bridge per year (includes preventive maintenance)

2. Other Indicators of Reliability:

The Jetway boarding bridge has been independently monitored for in-service reliability. Studies, conducted over a 22-month period on bridges approximately three years old, indicate an in-service percentage of greater than 99 percent. In other words, the Jetway electro-mechanical passenger



boarding bridge is out of service less than one percent of the time. In the case of the 47 bridges utilized for this study, for the 12 months surveyed, the total unscheduled down time was 89 hours for this population of bridges. This equates to an in-service performance rating of 99.98 percent.

Jetway recently concluded a study for Delta Air Lines. Delta owns 446 Jetway passenger boarding bridges. The mean age of the 446 boarding bridges surveyed was 18 years. Delta has contracted with Jetway to replace approximately 20 bridges per year beginning with those bridges that are 30 years old or older. ***The Jetway boarding bridge has a proven record of a 25 year life.***

Typically, the Jetway bridge requires very little in the way of corrective repair work. Records from various maintenance contracts indicate the following levels of performance:

<u>Description</u>	<u>Findings</u>
Avg service calls per year:.....	4.6 / year / boarding bridge
Mean Time Between Calls ALL Types (MTBF):	119 days / bridge
Mean Time to Repair (MTTR):	25 minutes / bridge / call
Avg bridge in-service percentage:	99.98% / bridge / year
Percent of calls actually requiring parts	15%

3. Preventative Maintenance Requirements:

Jetway recommends that the Jetway passenger boarding bridge be serviced on a quarterly basis. The quarterly preventive maintenance checks are fully detailed in the Jetway Maintenance and Operations Manual. The preventive maintenance checks include guidelines for inspecting, adjusting, lubricating, and touch-up painting the passenger boarding bridge.

Labor and materials required for the preventive maintenance checks include:

Labor:	Approximately 50 man-hours per bridge per year
Materials:	Approximately \$100 per bridge per year in lubricants and paint

4. Mean-Time-To-Repair of Key Components and Systems:

As indicated earlier, the Jetway passenger boarding bridge, even after a decade of service, has a very high record of in-service time. However, on occasion a motor or other key component will fail. Indicators outlining that failure rate and repair rate are listed below:

Mean-time-between-failure

Horizontal drive system:.....	9-12 years
Vertical drive system:	9-12 years
Main control board, electrical elements:	5-7 years
Motor, various:	5-7 years



Repair of these systems has been made easy by the modular design and easy access devices used on the Jetway passenger boarding bridge. Should a major component fail, it can usually be repaired within half a day. The mean-time-to-repair is as follows:

Mean-time-to repair of Major Components

Horizontal drive system:.....	4 hours
Vertical drive system:	5 hours
Ball screw:.....	12 hours
Motor:.....	4 hours
Main control board, electrical elements:	1 hour
Motors, various:.....	3-4 hours

In actual usage, the vast majority of service calls concern the replacement of consumables or general assistance to operator personnel. Studies of boarding bridge performance indicate that the major systems combined, account for less than eight percent of bridge repair calls and service time.

5. Summary:

The Jetway boarding bridge is an equipment asset designed to provide years of highly reliable, low-cost performance. Used throughout the world, the Jetway passenger transfer system has a proven record in the harsh environments associated with many modern airports. The Jetway Passenger Boarding Bridge is a cost-effective, market-tried means for servicing the aircraft of today's commercial fleets.

Apron Drive Passenger Boarding Bridge Power Consumption Report

Jetway recently conducted a test to determine the average power consumed during a single passenger boarding bridge operational cycle. The test procedure and results are noted below:

One complete cycle drove the apron drive bridge horizontally from a park position (position 1) approximately 16.47 meters (54 feet) while driving vertically up 1 meter (3.3 feet) and rotating the cab 28° to the park position (position 1). Horizontal swing was 17° in both directions. All tunnel lights were on.

Ten (10) complete docking cycles were completed with a watt hour meter connected to the three phase incoming power. The time to complete the test was 20 minutes, an average of 2 minutes per cycle.

The total kilo-watt hours for the 20 minute duration was 22.2 kwh. The test was performed at 480 Volt 60 Hertz. The current coils were wrapped with ten (10) turns to improve sensitivity; therefore the total watt hours will be divided by 10. An Esterline Angus Powermaster 3B meter was used to monitor power consumption.

$22.2\text{kwh} \times 3 = 66.6\text{kwh}$ in a 1-hour period

$66.6\text{kwh}/10 \text{ turns} = 6.66\text{kwh}$ (6,660wh)

$6,660\text{wh}/30 \text{ cycles per hour} = 222 \text{ watts per cycle}$ as described in paragraph 1

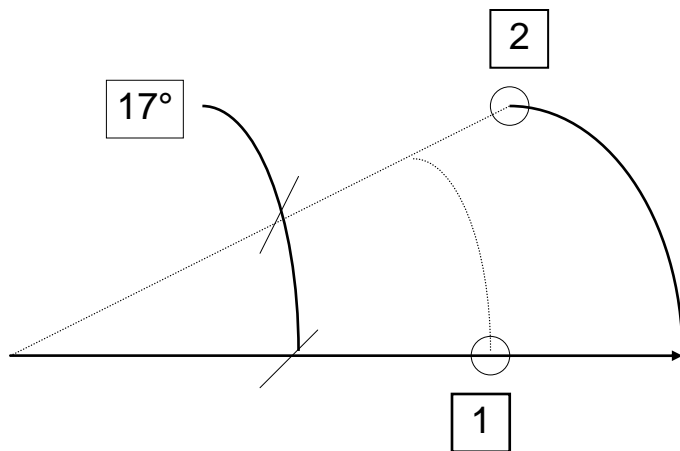

Electric motor parameters:

The following parameters are measured during the operating tests as reported above. Additional cyclic testing may have to be used to provide steady state data.

Attach the Spectrum Power Monitor (Fluke 71) to one phase of the incoming line.

Travel Direction	Vertical (2 motors)		Horizontal (2 motors)		Cab (1 motor)
	Down	Up	Forward	Reverse	
Start up intensity Amps (start current)	50.9	59.7	17.1	19.7	2.7
Set speed intensity Amps (running current)	6.0	10.6	12	12	1.7
Id/In Ratio (start current/ run current)	8.48	5.63	1.4	1.6	1.6
Absorbed Power Kilowatts	-0.44	1.93	2.5	2.5	0.26
Motor temperature °C	32		18		16
Ambient temperature °C	26		15		16
Power Factor	0.34	0.83	0.99	0.99	0.71

Values measured are for the system and contain the number of motors in parentheses.



Useful Life of Boarding Bridges

Introduction

Jetway has been manufacturing, installing and supporting, with parts and technical assistance, aircraft loading bridges since 1959. During these over fifty years of continuous production, Jetway has produced over 8,800 boarding bridges. The first boarding bridge order was placed by United Air Lines in 1959 for 15 bridges with the units destined for Los Angeles, San Francisco and LaGuardia. The last bridge from that original order of 15, located at New York's LaGuardia Airport, was finally replaced in 1991.

Design and Support

Jetway passenger boarding bridges are designed to last a minimum of 25 years when properly maintained.

Summary

The Jetway passenger boarding bridge is a time-tested, quantity-tested piece of equipment. Of the over 8,800 Jetway bridges installed over the past 52 years, we estimate less than 15 percent have been replaced. Used throughout the United States and the world, Jetway boarding bridges have proven themselves in every climate and operational condition - from Iceland to Saudi Arabia. No other boarding bridge is more reliable and no other boarding bridge manufacturer can match the longevity of parts and technical support.



LIFE CYCLE COST DATA

Typical Passenger Boarding Bridge

Apron Drive Bridge	Capital Cost	Maintenance			Energy kWh	Consumables	Cleaning Annual Costs
		Annual Parts Costs	Frequency	Downtime			
A3 68/141-125R	\$300,000	\$660	Quarterly	2.25 hr/yr	648 kWh/yr	\$205	\$1,263

A point of clarification must be made with respect to life cycle cost comparisons. Although Jetway Systems® takes great care to only utilize equivalent situations in presentation of our lifecycle data, others do not. For example, in a past bid, a competitor included several charts indicating a comparison between Jetway® products and theirs to substantiate their supposedly superior position with respect to maintenance and the reliability of their equipment. These particular charts were presented without any reference data on the charts to identify the information from whence they came. In a brief statement on an attached page, the source of the data was identified as being taken within the last four years. What was not mentioned was that Jetway® bridges had been installed in August of 1981. As a result, the customer was unwittingly being led to compare 28-year-old Jetway® bridges against one to three-year-old competitive bridges. This situation almost guarantees a skewed comparison.

As indicated above, lifecycle comparison data can be constructed and construed to support a given perception. Since Jetway® created the passenger boarding bridge industry in 1959 and has by far the greatest number of passenger boarding bridges in service, it is not uncommon that the comparisons offered by companies with significantly less market presence are not of equivalent situations. We seek to include information that is relevant to the customer and publicly available because it is auditable and reliable. It is to the customer's best interest to validate the underlying information presented in any product comparison in order to assure a fair and accurate decision.

JETWAY®
Apron Drive 2 & 3 Tunnel
PLC Bridge

Section 7: Annual Preventive Maintenance Checklists

DESCRIPTION	DATE	GOOD	REPAIRED or LUBRICATED	MECHANIC
and loose bolts:				
a. Lower rotunda column				
b. Upper rotunda column and torque box				
c. Rotunda to 'A' tunnel hinge pins and clevis connections and clevis mounting points (left and right side)				
d. Stair landing support structure				
e. Service stair and mounting attachment points				
f. Upper vertical lift column attachment points				
g. Lower vertical lift column attachment points				
h. Vertical lift column to cross tube attachment points				
i. Lower wheel bogie swivel-bearing and trunnion pins and associated weldments				
j. Cab pivot bracket and tie rod connection points				
<p>⚠ WARNING: WELD JOINTS CAN SUFFER STRESS AND FATIGUE IN CRITICAL AREAS OF THE PASSENGER BOARDING BRIDGE OVER TIME FROM IMPACTS AND ABUSE THAT CAN RESULT IN CRACKS AND JOINT FAILURES.</p>				
<p>⚠ WARNING: EXCESSIVE CORROSION CAN WEAKEN STRUCTURAL COMPONENTS.</p>				
<p>⚠ WARNING: STRUCTURAL BOLTS MUST NOT BE ALLOWED TO BECOME LOOSE OR LOSE THEIR PRE-TENSION LOAD OR TORQUE.</p>				
<p>⚠ WARNING: FAILURE TO PERFORM THESE INSPECTIONS CAN RESULT IN SERIOUS PERSONAL INJURY, DEATH AND/OR PROPERTY DAMAGE.</p>				
34.	Ball Screw Inspection			
	Inspect the Vertical Drive ball screw after ten (10) years of service for excessive			

JETWAY®
Apron Drive 2 & 3 Tunnel
PLC Bridge

Section 7: Annual Preventive Maintenance Checklists

	DESCRIPTION	DATE	GOOD	REPAIRED or LUBRICATED	MECHANIC
	corrosion, cracking, pitting, gouges, brinelling or unusual wear of the ball grooves. After this initial inspection, inspect the ball screw every five (5) years. (See Figure 1)				



This drawing and any associated information or amendments are proprietary and confidential to JBT AeroTech. This drawing may not be reproduced in full or in part and cannot be disclosed to any other party without the prior written consent of JBT AeroTech.

INSPECT THIS AREA FOR EXCESSIVE WEAR, CORROSION, CRACKING, PITTING, GOUGES, OR BRINELLING USING DYE PENETRANT.

Inspection of Ball Screw
 Figure 1



11. Discuss the Maintenance Cycles for the product proposed. Identify all of the recommended the Periodic Maintenance and all other maintenance cycles.

See attached "Maintenance Cycles."

Passenger Boarding Bridge Preventive Maintenance Program

JBT AeroTech, Jetway Systems[®] is pleased to provide the following information to inform you of the requirements associated with the development of a comprehensive preventive maintenance program for passenger boarding bridges. Attached are the preventive maintenance check sheets that outline the scope of work associated with each quarterly preventive maintenance inspection.

Preventive Maintenance:

Preventive maintenance is to be completed per the requirements outlined in our Maintenance Manual. The specific scope of work requirements for each of the scheduled preventive maintenance inspections are identified in the attached Annual, Semi-Annual, and Quarterly Preventive Maintenance Instructions. The preventive maintenance program will need to be scheduled by your local Maintenance Project Manager who will coordinate with airport operations to schedule PBB equipment to be out of service for the duration required for each specific maintenance check. In most cases the duration of the maintenance for each PBB will be as follows:

1st Quarter Inspection	4 Hours
2nd Quarter Semi-Annual Inspection	8 Hours
Semi-Annual Power Wash	4 Hours
3rd Quarter Inspection	4 Hours
4th Quarter Inspection Annual Inspection	10 Hours
Annual Power Wash/Touch-Up Painting	6 Hours

There are normally two persons required to execute the preventive maintenance program, so the actual man hours required to complete the maintenance work should be double those shown above.



Apron Drive 2 & 3 Tunnel Passenger Boarding Bridge

Quarterly Preventive Maintenance

DESCRIPTION		DATE	GOOD	REPAIRED or LUBRICATED	MECHANIC
1.	Drive the bridge to all limits to detect any operational problems.				
2.	Manipulate the following limit switches by hand making sure they work properly:				
	a. Rotunda Rotation				
	b. Slope Limits				
3.	Check Cab Rotation				
	a. Rotate the cab full right and left. Operation should be smooth.				
4.	Check canopy closure operation.				
NOTE: When checking the canopy do not place the bridge against an aircraft.					
	a. Left side raise - the motor will stop running when the canopy is full up.				
	b. Right side raise - the motor will stop running when the canopy is full up.				
	c. Lower the canopy, either side, a few inches. The canopy down message will appear and the bridge will not drive forward.				
	d. Left side down - extend the curtain until the clutch is engaged indicated by a clicking sound.				
	e. Right side down - extend the curtain until the clutch is engaged indicated by a clicking sound.				
5.	Horizontal Drive				



Apron Drive 2 & 3 Tunnel Passenger Boarding Bridge

Quarterly Preventive Maintenance

DESCRIPTION		DATE	GOOD	REPAIRED or LUBRICATED	MECHANIC
	a. Drive the bridge full forward - the slow down circuit will activate about 3 feet before full extend is reached, and the bridge will stop before reaching the mechanical stops.				
	b. Drive the bridge full reverse - the slow down circuit will activate about 3 feet before full retract is reached, and the bridge will stop before reaching the mechanical stops.				
	c. Insure the travel warning bell is ringing whenever the bridge is moving.				
	d. Rotate the horizontal drive to its right and left limits. Drive unit should stop at the preset limits.				
NOTE: All movement should be smooth in operation. If the operation is jerky and/or noisy, check for obstructions on the roller tracks.					
6.	Vertical Drive				
	a. Raise and lower the bridge - operation should be smooth.				
	b. Raise and lower the bridge to its upper and lower limits. The bridge should stop at the preset heights.				
	c. Inspect vertical lift column chain coupling (See chapter 4 Section 3 for procedures).				
7.	Vertical lift column fault limit switches.				
	NOTE: Check only one limit switch at a time.				



Apron Drive 2 & 3 Tunnel Passenger Boarding Bridge

Quarterly Preventive Maintenance

DESCRIPTION		DATE	GOOD	REPAIRED or LUBRICATED	MECHANIC
	a. Remove limit switch and manually trip while a second person attempts to raise or lower the bridge. If the bridge raises or lowers the limit switch must be replaced.				
	b. Repeat this procedure on the other limit switch.				
NOTE: Any shims that are removed or that may fall free during this process must be replaced before re-securing the limit switches.					
8.	Inspect the operators console.				
	a. Check for moisture, rust, and debris.				
	b. Check all printed circuit boards, wire connections and other components for secure mounting.				
	c. Check for any evidence of arching or pitting signaling loose connections.				
	d. Indicator lights, meters and wiring in general.				
9.	Observe the cable carrier system while retracting and extending the bridge to insure system does not bind.				
10.	Check rotunda access panel and hold down clamps for secure mounting.				
11.	Check rotunda side curtains for tightness and adjust if necessary.				
12.	Check cab side curtains for tightness and adjust if necessary.				
13.	Check the following electrical cables for deterioration and general condition.				
	a. Exposed cables under tunnels.				



Apron Drive 2 & 3 Tunnel Passenger Boarding Bridge

Quarterly Preventive Maintenance

DESCRIPTION		DATE	GOOD	REPAIRED or LUBRICATED	MECHANIC
	b. Exposed cables under cab.				
	c. Cables from rotunda to tunnel A.				
	d. 400Hz Aircraft power input cable (if applicable)				
14.	Check tunnel equalizing cable and adjust if necessary.				
15.	Auto Level				
	a. Check the set screws holding the wheel to the limit switch, they should be tight.				
	b. Turn the wheel by hand in both directions insuring freedom of operation and positive return to neutral.				
NOTE: Turning the wheel approximately 15° in either direction will engage the limit switch.					
	c. Check the arm - it should move freely in both directions.				
	d. Check the auto level travel limits with the arm extended and the bridge in "AUTO LEVEL" mode.				
	By hand turn and hold the wheel to simulate the aircraft rising. About 4 seconds will pass before the auto level warning light and bell come on.				
	Reset the auto level system and check the down travel by turning and holding the wheel in the opposite direction. About 4 seconds will pass and the warning light and bell come on.				



Apron Drive 2 & 3 Tunnel Passenger Boarding Bridge

Quarterly Preventive Maintenance

DESCRIPTION	DATE	GOOD	REPAIRED or LUBRICATED	MECHANIC
16. Lift the console faceplate and clean the touch screen and the glass cover with a good quality glass cleaner.				
17. Lubricate the following:				
NOTE: See Chapter 2, Section 3 for lubrication points and Chapter 2, Section 4 for the Table of Lubricants.				
a. Vertical lift column ball screw assembly through the oil cup on top of each column using lube spec #2. Use 6 oz. of lubricant.				
NOTE: After lubrication the bridge must be driven to extreme UP and DOWN limits several times to insure proper distribution of the lubricant.				



**Apron Drive 2 & 3 Tunnel
Passenger Boarding Bridge**

Semi-Annual Preventive Maintenance

DESCRIPTION	DATE	GOOD	REPAIRED or LUBRICATED	MECHANIC
1. Drive the bridge to all limits to detect any operational problems.				
2. Manipulate the following limit switches by hand making sure they work properly:				
a. Rotunda Rotation				
b. Slope Limits				
3. Check Cab Rotation				
a. Rotate the cab full right and left. Operation should be smooth.				
4. Check canopy closure operation.				
NOTE: When checking the canopy do not place the bridge against an aircraft.				
a. Left side raise - the motor will stop running when the canopy is full up.				
b. Right side raise - the motor will stop running when the canopy is full up.				
c. Lower the canopy, either side, a few inches. The canopy down message will appear on the CRT and the bridge will not drive forward.				
d. Left side down - extend the curtain until the clutch is engaged indicated by a clicking sound.				
e. Right side down - extend the curtain until the clutch is engaged indicated by a clicking sound.				
5. Horizontal Drive				
a. Drive the bridge full forward - the slow down circuit will activate about three feet before full extend is reached, and the bridge will stop before reaching the mechanical stops.				
b. Drive the bridge full reverse - the slow down circuit will activate about three feet before full retract is reached, and the bridge will stop before reaching the mechanical stops.				
c. The travel warning bell is ringing whenever the bridge is moving.				
d. Rotate the horizontal drive to its right and left limits. Drive unit should stop at the preset limits.				



**Apron Drive 2 & 3 Tunnel
Passenger Boarding Bridge**

Semi-Annual Preventive Maintenance

DESCRIPTION	DATE	GOOD	REPAIRED or LUBRICATED	MECHANIC
NOTE: All movement should be smooth in operation. If the operation is jerky and/or noisy, check for obstructions on the roller tracks.				
6.	Vertical Drive			
	a. Raise and lower the bridge - operation should be smooth.			
	b. Raise and lower the bridge to its upper and lower limits. The bridge should stop at the preset heights.			
	c. Inspect vertical lift column chain coupling (See chapter 4 Section 3 for procedures).			
7.	Vertical lift column fault limit switches.			
NOTE: Check only one limit switch at a time.				
	a. Remove limit switch and manually trip while a second person attempts to raise or lower the bridge. If the bridge raises or lowers the limit switch must be replaced.			
	b. Repeat this procedure on the other limit switch.			
NOTE: Any shims that are removed or that may fall free during this process must be replaced before re-securing the limit switches.				
8.	Inspect the operator's console.			
	a. Check for moisture, rust, and debris.			
	b. Check all printed circuit boards, wire connections and other components for secure mounting.			
	c. Check for any evidence of arching or pitting signaling loose connections.			
	d. Indicator lights, meters and wiring in general.			
9.	Observe the cable carrier system while retracting and extending the bridge to insure system does not bind.			
10.	Check rotunda access panel and hold down clamps for secure mounting.			
11.	Check rotunda side curtains for tightness and adjust if necessary.			
12.	Check cab side curtains for tightness and adjust if necessary.			



**Apron Drive 2 & 3 Tunnel
Passenger Boarding Bridge**

Semi-Annual Preventive Maintenance

DESCRIPTION	DATE	GOOD	REPAIRED or LUBRICATED	MECHANIC
13. Check the following electrical cables for deterioration and general condition.				
a. Exposed cables under tunnels.				
b. Exposed cables under cab.				
c. Cables from rotunda to tunnel A.				
d. 400Hz Aircraft power input cable (if applicable)				
14. Check tunnel equalizing cable and adjust if necessary.				
15. Auto Level				
a. Check the set screws holding the wheel to the limit switch, they should be tight.				
b. Turn the wheel by hand in both directions insuring freedom of operation and positive return to neutral.				
NOTE: Turning the wheel approximately 15° in either direction will engage the limit switch.				
c. Check the arm - it should move freely in both directions.				
d. Check the auto level travel limits with the arm extended and the CRT in the "AUTO LEVEL" mode.				
By hand turn and hold the wheel to simulate the aircraft rising. About 4 seconds will pass before the auto level warning light and bell come on.				
Reset the auto level system, check the down travel by turning and holding the wheel in the opposite direction. About 4 seconds will pass before the warning light and bell come on.				
16. Lift the console faceplate and clean the touch screen and the glass cover with a good quality glass cleaner.				
17. Check the following weather seals for general condition:				
a. rotunda to building				
b. splice seals, if applicable				



**Apron Drive 2 & 3 Tunnel
Passenger Boarding Bridge**

Semi-Annual Preventive Maintenance

DESCRIPTION	DATE	GOOD	REPAIRED or LUBRICATED	MECHANIC
c. bellows seals between tunnels, if applicable.				
18. Thoroughly wash bridge exterior as per Chapter 2, Section 10.				
19. Inspect exterior paint for chips, cracks and rust.				
20. Check tunnel roller tracking and adjust if necessary.				
21. Inspect interior paint for chips, cracks and rust.				
22. Check the following mounting bolts for tightness:				
a. Horizontal Drive				
b. Vertical Lift Column				
c. Landing				
d. Rotunda Column Splice, if applicable				
e. Walkway Haunch Splice, if applicable				
<p>NOTE: If any of the above mounting bolts are loose, they must be replaced with ASTM A325 bolts (refer to Fastener Identification Chart in Appendix A), ASTM 563 nuts (identified by three (3) radial lines on nut), and flat hardened washers. All replacement bolts and nuts should be coated to prevent corrosion. The new bolts should be tightened as described in the Bolt Torque Requirement section of Chapter 4, Section 7. Only remove and replace one bolt at a time.</p> <p>NOTE: The tightening of the new bolt may cause other bolts in the joint to loosen. Therefore, after tightening the new bolt, re-verify the tightness of the remaining bolts. Repeat the procedure until all the bolts are tight. If more than one bolt in a joint is loose, then all of the bolts in the joint should be replaced and tightened (one at a time).</p>				
23. Check rotunda floor alignment				
24. Check drain spouts in tunnel floor gutters. Make certain they are not clogged with debris and will pass water.				
25. Check tires				
a. Check air pressure and fill, if necessary.				
b. Check general condition of tires.				
26. Lubricate the following:				
<p>NOTE: See Chapter 2, Section 3 for lubrication points and Chapter 2, Section 4 for the Table of Lubricants.</p>				
a. Vertical lift column ball screw assembly through the oil cup on top of each column using lube spec #2. Use 6 oz. of lubricant.				



**Apron Drive 2 & 3 Tunnel
Passenger Boarding Bridge**

Semi-Annual Preventive Maintenance

DESCRIPTION	DATE	GOOD	REPAIRED or LUBRICATED	MECHANIC
NOTE: After lubrication the bridge must be driven to extreme UP and DOWN limits several times to insure proper distribution of the lubricant.				
b. Vertical lift column thrust bearings with lube spec #1.				
c. Rotunda column flange and sleeve bearings with lube spec #1.				
d. Cab canopy mechanical parts with lube spec #3.				
1) Actuator pivot point.				
2) Lower actuator arm pivot point.				
3) Lower actuator arm bushings.				
4) Pivot Block				
5) Lower hinges				
e. Wheel Carriage and Swivel Column				
1) Drive chains with lube spec #2.				
2) Turret Bearing with lube spec #1.				
3) Bushings and Trunnion pin with lube spec #3				
NOTE: The wheel bearings should be lubricated each time the wheel assemblies are torn down with lube spec #3.				
f. Cable lift arm hinges with lube spec #3.				
g. Cab rotation parts as follows:				
1) Drive chains with lube spec #2.				
2) Sprocket shafts with lube spec #3.				
27. After lubrication operate the bridge to all limits to distribute lubrication.				



**Apron Drive 2 & 3 Tunnel
Passenger Boarding Bridge**

Annual Preventive Maintenance

Page 1

DESCRIPTION	DATE	GOOD	REPAIRED or LUBRICATED	MECHANIC
1. Drive the bridge to all limits to detect any operational problems.				
2. Manipulate the following limit switches by hand making sure they work properly:				
a. Rotunda Rotation				
b. Slope Limits				
3. Check Cab Rotation				
a. Rotate the cab full right and left. Operation should be smooth.				
4. Check canopy closure operation.				
NOTE: When checking the canopy do not place the bridge against an aircraft.				
a. Left side raise - the motor will stop running when the canopy is full up.				
b. Right side raise - the motor will stop running when the canopy is full up.				
c. Lower the canopy, either side, a few inches. The canopy down message will appear on the monitor and the bridge will not drive forward.				
d. Left side down - extend the curtain until the clutch is engaged indicated by a clicking sound.				
e. Right side down - extend the curtain until the clutch is engaged indicated by a clicking sound.				
5. Horizontal Drive				



**Apron Drive 2 & 3 Tunnel
Passenger Boarding Bridge**

Annual Preventive Maintenance

Page 2

DESCRIPTION	DATE	GOOD	REPAIRED or LUBRICATED	MECHANIC
a. Drive the bridge full forward - the slow down circuit will activate about 3 feet before full extend is reached, and the bridge will stop before reaching the mechanical stops.				
b. Drive the bridge full reverse - the slow down circuit will activate about 3 feet before full retract is reached, and the bridge will stop before reaching the mechanical stops.				
c. Insure the travel warning bell is ringing whenever the bridge is moving.				
d. Rotate the horizontal drive to its right and left limits. Drive unit should stop at the preset limits.				
NOTE: All movement should be smooth in operation. If the operation is jerky and/or noisy, check for obstructions on the roller tracks.				
6. Vertical Drive				
a. Raise and lower the bridge - operation should be smooth.				
b. Raise and lower the bridge to its upper and lower limits. The bridge should stop at the preset heights.				
c. Inspect vertical lift column chain coupling (See chapter 4 Section 3 for procedures).				
7. Vertical lift column fault limit switches.				
NOTE: Check only one limit switch at a time.				



**Apron Drive 2 & 3 Tunnel
Passenger Boarding Bridge**

Annual Preventive Maintenance

Page 3

	DESCRIPTION	DATE	GOOD	REPAIRED or LUBRICATED	MECHANIC
	a. Remove limit switch and manually trip while a second person attempts to raise or lower the bridge. If the bridge raises or lowers the limit switch must be replaced.				
	b. Repeat this procedure on the other limit switch.				
	NOTE: Any shims that are removed or that may fall free during this process must be replaced before re-securing the limit switches.				
8.	Inspect the operators console.				
	a. Check for moisture, rust, and debris.				
	b. Check all printed circuit boards, wire connections and other components for secure mounting.				
	c. Check for any evidence of arching or pitting signaling loose connections.				
	d. Indicator lights, meters and wiring in general.				
9.	Observe the cable carrier system while retracting and extending the bridge to insure system does not bind.				
10.	Check rotunda access panel and hold down clamps for secure mounting.				
11.	Check rotunda side curtains for tightness and adjust if necessary.				
12.	Check cab side curtains for tightness and adjust if necessary.				
13.	Check the following electrical cables for deterioration and general condition.				
	a. Exposed cables under tunnels.				



**Apron Drive 2 & 3 Tunnel
Passenger Boarding Bridge**

Annual Preventive Maintenance

Page 4

	DESCRIPTION	DATE	GOOD	REPAIRED or LUBRICATED	MECHANIC
	b. Exposed cables under cab.				
	c. Cables from rotunda to tunnel A.				
	d. 400Hz Aircraft power input cable (if applicable)				
14.	Check tunnel equalizing cable and adjust if necessary.				
15.	Auto Level				
	a. Check the set screws holding the wheel to the limit switch, they should be tight.				
	b. Turn the wheel by hand in both directions insuring freedom of operation and positive return to neutral.				
	NOTE: Turning the wheel approximately 15° in either direction will engage the limit switch.				
	c. Check the arm - it should move freely in both directions.				
	d. Check the auto level travel limits with the arm extended and the monitor in the "AUTO LEVEL" mode.				
	By hand turn and hold the wheel to simulate the aircraft rising. About 4 seconds will pass before the auto level warning light and bell come on.				
	Reset the auto level system and check the down travel by turning and holding the wheel in the opposite direction. About 4 seconds will pass and the warning light & bell come on.				



**Apron Drive 2 & 3 Tunnel
Passenger Boarding Bridge**

Annual Preventive Maintenance

Page 5

DESCRIPTION		DATE	GOOD	REPAIRED or LUBRICATED	MECHANIC
16.	Lift the console faceplate and clean the touch screen and the glass cover with a good quality glass cleaner.				
17.	Check the following weather seals for general condition:				
	a. rotunda to building				
	b. splice seals, if applicable				
	c. bellows seals between tunnels, if applicable.				
18.	Thoroughly wash bridge exterior as per Chapter 2, Section 10.				
19.	Inspect exterior paint for chips, cracks and rust.				
20.	Check tunnel roller tracking and adjust if necessary.				
21.	Inspect interior paint for chips, cracks and rust.				
22.	Check the following mounting bolts for tightness:				
	a. Horizontal Drive				
	b. Vertical Lift Column				
	c. Landing				
	d. Rotunda Column Splice, if applicable				
	e. Walkway Haunch Splice, if applicable				
<p>NOTE: If any of the above mounting bolts are loose, they must be replaced with ASTM A325 bolts (refer to Fastener Identification Chart in Appendix A), ASTM 563 nuts (identified by three (3) radial lines on nut), and flat hardened washers. All replacement bolts and nuts should be coated to prevent corrosion. The new bolts should be tightened as described in the Bolt Torque Requirement section of Chapter 4, Section 7. Only remove and replace one bolt at a time.</p>					



**Apron Drive 2 & 3 Tunnel
Passenger Boarding Bridge**

Annual Preventive Maintenance

Page 6

	DESCRIPTION	DATE	GOOD	REPAIRED or LUBRICATED	MECHANIC
	<p>NOTE: The tightening of the new bolt may cause other bolts in the joint to loosen. Therefore, after tightening the new bolt, re-verify the tightness of the remaining bolts. Repeat the procedure until all the bolts are tight. If more than one bolt in a joint is loose, then all of the bolts in the joint should be replaced and tightened (one at a time).</p>				
23.	Check rotunda floor alignment				
24.	Check drain spouts in tunnel floor gutters. Make certain they are not clogged with debris and will pass water.				
25.	Check tires				
	a. Check air pressure and fill, if necessary.				
	b. Check general condition of tires.				
26.	Inspect the lift column slide pads (See Chapter 2, Section 8 for procedures)				
27.	Check the horizontal drive chains and sprockets for signs of streaking, cracking, rusting or pitting.				
28.	Inspect the following brakes:				
	NOTE: See Chapter 2, Section 8 for inspection and adjustment procedures.				
	a. Vertical Drive				
	b. Horizontal Drive				
	c. Cab Rotation				
	d. 400 Hz Hoist motor (if equipped)				



**Apron Drive 2 & 3 Tunnel
Passenger Boarding Bridge**

Annual Preventive Maintenance

Page 7

	DESCRIPTION	DATE	GOOD	REPAIRED or LUBRICATED	MECHANIC
29.	Inspect the Vertical Drive ball screw after ten (10) years of service for excessive wear, corrosion, cracking, pitting, gouges or brinelling. If any of these conditions exist, the ball screw may need replacement and further inspection is required. Refer to section 4 - 3 of this manual for ball screw removal and appendix B for inspection procedures. After this initial inspection inspect the ball screw every five (5) years. (See Figure 1)				
30.	Lubricate the following:				
	NOTE: See Chapter 2, Section 3 for lubrication points and Chapter 2, Section 4 for the Table of Lubricants.				
	a. Vertical lift column ball screw assembly through the oil cup on top of each column using lube spec #2. Use 6 oz. of lubricant.				
	NOTE: After lubrication the bridge must be driven to extreme UP and DOWN limits several times to insure proper distribution of the lubricant.				
	b. Vertical lift column thrust bearings with lube spec #1.				
	c. Rotunda column flange and sleeve bearings with lube spec #1.				
	d. Cab canopy mechanical parts with lube spec #3.				
	1) Actuator pivot point.				
	2) Lower actuator arm pivot point.				
	3) Lower actuator arm bushings.				
	4) Pivot Block				
	5) Lower hinges				
	e. Wheel Carriage and Swivel Column				
	1) Drive chains with lube spec #2.				



**Apron Drive 2 & 3 Tunnel
Passenger Boarding Bridge**

Annual Preventive Maintenance

Page 8

	DESCRIPTION	DATE	GOOD	REPAIRED or LUBRICATED	MECHANIC
	2) Turret Bearing with lube spec #1.				
	3) Bushings and Trunnion pin with lube spec #3				
	NOTE: The wheel bearings should be lubricated each time the wheel assemblies are torn down with lube spec #3.				
	f. Cable lift arm hinges with lube spec #3.				
	g. Cab rotation parts as follows:				
	1) Drive chains with lube spec #2.				
	2) Sprocket shafts with lube spec #3.				
	h. Rotunda hinge pins with lube spec #1.				
31.	After lubrication operate the bridge to all limits to distribute lubrication.				



In addition to the disposal requirements above, is there a secondary market for these units? What is the average cost that is experienced by your products in those markets?

What is the percentage of material and/or equipment that is made in the USA?

What is the percentage of recyclable or reusable material and/or equipment proposed?

The after-market or resale market for used bridges is quite active at present. Value of bridges is based on several subjective criteria, age of the asset, manufacturer, bridge type and size, maintenance history and location.

While the bridge is essentially a steel structure, care has to be taken to ensure that there has not been undue stress placed on the structure or damage from external forces. Many potential buyers do not want to invest in a bridge older than 10 years old to ensure structural stability. Eighteen years old is usually considered the oldest candidate for refurbishment. Potential buyers often want to upgrade the bridge to a like new condition often paying up to 80% of a new bridge price to bring the asset to current standards.

It is undisputable that Jetway passenger boarding bridges hold their value longer than other manufacturers' equipment. This is due to the durability of design and parts availability. Of the bridges that are being replaced three are manufactured by Stearns and three are manufactured by JBT AeroTech – Jetway Systems. The Jetway bridges were installed at Stapleton in 1987 and move to DIA in 1994/1995. The Stearns bridges are original to DIA in 1994/1995. The Jetway bridges are common sought after sizes while the Stearns bridges are a bit more uncommon considering their issues with hydraulics, tunnel rollers and sail track cables. It is likely that given the right buyer you could get approximately \$10,000 for the Jetway bridges. The Stearns bridges may not have any market value or at least something less than the Jetway bridges

Made in the USA

The boarding bridges being proposed are manufactured in Ogden, Utah, as they have been since 1961. Although the content can vary depending on the options or configuration of the bridge we are consistently in the 89-92% range for US content.

Recycled Content

JBT Corporation is committed to reducing its environmental footprint. The steel and copper in the bridge are comprised of recycled metals but it is hard to identify the exact content as it varies from buy to buy. Further our plywood material for the subfloors utilizes a percentage of reconstituted wood product as does the carpet manufacturer.

JETWAY® APRON DRIVE PASSENGER BOARDING BRIDGES

We are a world leader in aircraft ground support equipment

JBT AeroTech, Jetway Systems® offers unparalleled product range and support and the convenience of a single source supplier: Jetway® passenger boarding bridges, JetPower® 400Hz ground power units, JetAire® preconditioned air units, and other ground support systems.

With successful innovations we have served the airport industry since 1959. Let our expertise provide you the utmost in cost-efficient solutions for your gate operations.



www.jbtaerotech.com



Jetway Systems®

United States
JBT Aerotech
Jetway Systems®
1805 West 2550 South
Ogden, Utah 84401
Tel: 1-801-627-6600
Fax: 1-801-629-3474

China
JBT Aerotech
Suite 709-710, 7th Floor,
Tower 1, Silvercord,
30 Canton Road,
Tsim Sha Tsui (TST)
Hong Kong
Tel: 852-3966-1360
Fax: 852-3966-1361

United Arab Emirates
JBT Aerotech
PO Box 263001
JAFZ, Dubai
Tel: 971-50-655-6490
Fax: 971-4-881-2009

United Kingdom
JBT Aerotech
658 River Gardens
North Feltham Trading Estate
Hounslow, Middlesex
TW14 ORB
Tel: 44-20-8587-0666
Fax: 44-20-8587-0660

FROM TOUCH DOWN TO TAKE-OFF

JBT AeroTech, Jetway Systems®, a global leader in the manufacturing of airport ground support equipment, has the solution for faster aircraft turn times, lower operating costs, and improved asset management: Jetway® passenger boarding bridges, JetPower® 400Hz ground power, JetAire® preconditioned air units; JetFlo® potable water cabinets, BagBuddy™ luggage lift, and Apron Management Systems (AMS).



JBT AeroTech, Jetway Systems®, offers field support for all of our equipment. Our staff of engineers, field-technicians, and project managers work directly with our customers to ensure the highest level of customer satisfaction.

CUSTOMIZED. Each Jetway® Apron Drive Bridge is manufactured per our customer's specifications: exterior color, interior design, and the tunnel configuration.

CLEAN. The bridge cable carrying system is placed under the bridge for improved aesthetics, ease of maintenance, and expansibility. The cable system works in conjunction with the JetLink® delivery system to deliver power, AC, and potable water to the aircraft.

SAFE. To safely move passengers through the multiple bridge tunnels, each bridge has an extended, flattened transition ramp to reduce slipping or stumbling with the change in gradient. Our bridges meet the safety requirements for fire protection as stated by the National Fire Protection Association Code, Sec. 415.

FUNCTIONAL. The Jetway® Apron Drive Bridge from JBT AeroTech, has a versatile range-of-motion which allows it to service regional jets as well as the A380. The bridge uses an electromechanical design for horizontal movement. Vertical movement is achieved by using electromechanical or hydraulic configurations. Jetway® Passenger Boarding Bridges are manufactured with continuous solid-weld seams. There are no gaps to allow water to seep through and no need for caulking.

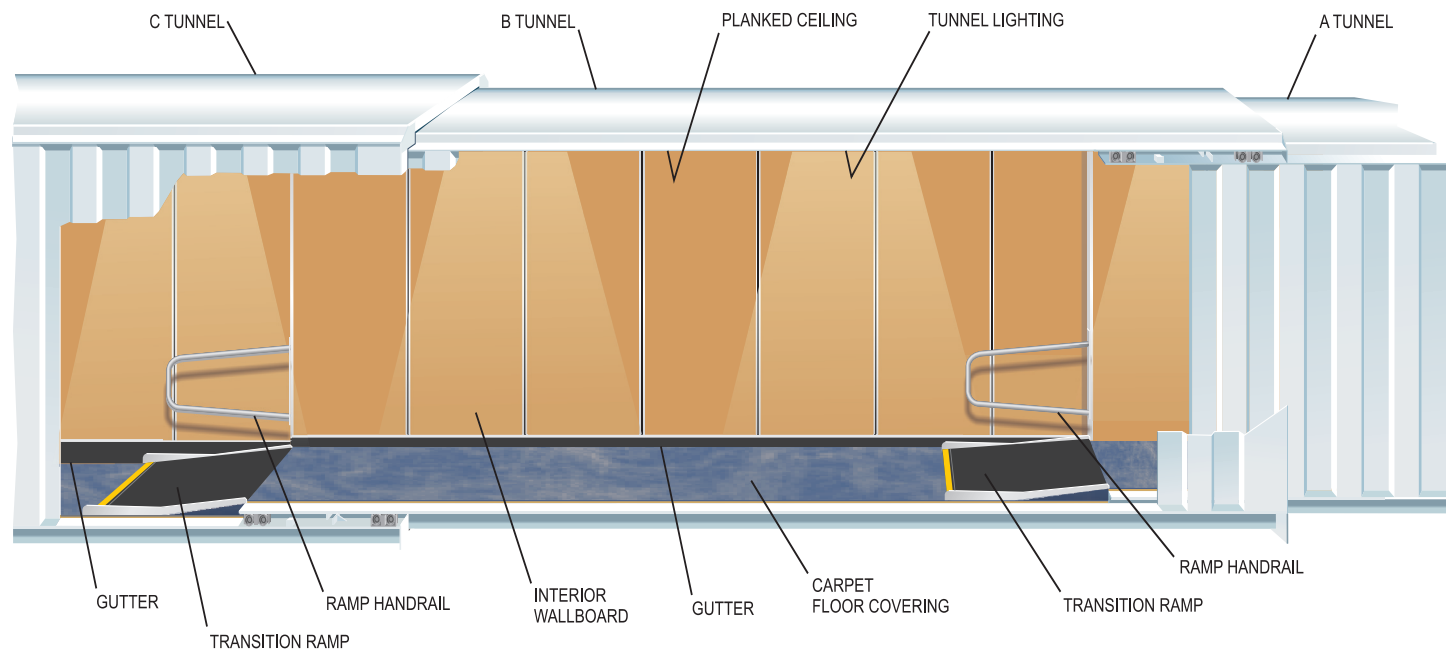

Jetway® Apron Drive Bridges utilize advanced technology and quality control systems to guarantee the longevity of the bridge and passenger comfort.

CANOPY. The independently actuated bellows form a tight weather seal between the aircraft and the bridge.

DOUBLE SWING DOORS. The doors provide all-weather protection and provide increased visibility for the operator.

SOLID RUBBER TIRES. The use of solid rubber tires reduces maintenance for the customer. Unlike traditional pneumatic tires, our solid rubber tires have a projected life of 10 years.



CE FLOOR. The CE Floor is available for the Jetway cab area. This option allows the bridge to service regional jets, as well as narrow and wide body aircraft.

EASY. Jetway® passenger boarding bridges are operated using Programmable Logic Controller (PLC). The PLC is programmed to warn and direct the operator. An Operator Interface Terminal and push-button controls promote easy operation.

We offer the perfect solution for boarding passengers while providing ground power, preconditioned air, and potable water to the aircraft. These are integrated to the bridge thus eliminating in-ground installations and ramp vehicle congestion around the aircraft. The ancillary equipment can be linked to the bridge allowing the operator to monitor it from the control panel within the bridge or from a remote location when using our Apron Management System (AMS).





Jetway® Corrugated Passenger Boarding Bridges





**Specification
Steel Apron Drive
PLC Controlled
Passenger Boarding Bridge
Electro-Mechanical**



**PLC CONTROLLED
APRON DRIVE PASSENGER BOARDING BRIDGE
ELECTRO MECHANICAL**

TABLE OF CONTENTS

GENERAL.....	2
ROTUNDA.....	2
TUNNEL.....	3
SERVICE ACCESS.....	4
CONTROL STATION	5
CONTROL INTERFACES AND INDICATORS.....	6
MAINTENANCE AND SET UP SCREENS.....	10
UTILITIES.....	11
CONTROL FEATURES AND INTERLOCKS.....	11
AIRCRAFT CAB	12
AIRCRAFT CLOSURE.....	13
AUTOMATIC LEVELING	13
DRIVE COLUMN.....	14
INTERIOR FINISHES.....	15
EXTERIOR FINISHES.....	17
MISCELLANEOUS PARTS	17
DESIGN CRITERIA.....	18
MANUALS AND TRAINING.....	20
WARRANTY.....	21



SPECIFICATION

CORRUGATED, PLC CONTROLLED

APRON DRIVE PASSENGER BOARDING BRIDGE

A. GENERAL

This specification describes the JBT AeroTech, Jetway Systems[®] corrugated walled or smooth walled; Programmable Logic Controller (PLC) controlled, Apron Drive Passenger Boarding Bridge with standard equipment.

The Jetway[®] Apron Drive Passenger Boarding Bridges (hereafter referred to as PBB) covered by this specification shall be designed to extend from a terminal departure lounge doorway to the aircraft boarding door. The design shall enable passengers to walk between the terminal and the aircraft in a protected environment. The complete assembly shall be protected against inclement weather conditions, both when sealed against an aircraft and when parked with the weather door closed.

NOTE: The observer shall be positioned with his/her back to the terminal end and facing the aircraft end of the PBB when referring to left or right.

B. DETAILED DESCRIPTION

1. The Rotunda Assembly

The Rotunda assembly shall be made up of a corridor, rotunda, and support column. The assembly shall be designed so that no loads or vibrations shall be transmitted to the building.

The rotunda assembly shall be designed as the terminal-end pivot for the PBB's vertical and horizontal motion. As the main pivot for the PBB, the rotunda assembly allows the PBB to swing a total of 175 degrees, 87-1/2 degrees clockwise and 87-1/2 degrees counterclockwise from the corridor centerline.

Slope, over-travel, and operational swing limits shall be located on the rotunda assembly. Slope limits shall be adjustable up to 10% (5.71°) for both up and down slopes. This limit shall be adjustable to meet local operating conditions and requirements.

The ultimate over-travel swing limit switch shall be located on the support column. This shall be an ultimate limit, serving as backup to the operational limits. The trip plate for the ultimate limit switch shall be located on the rotunda and shall be adjustable to meet local conditions. When the switch is actuated, all control power is cut off. When the switch is tripped, the PBB can only be moved by Maintenance Personnel using the by-pass switch in the control console.

The rotunda frame shall be equipped with rubber-bumper-type, mechanical stops to prevent over-retraction of the telescoping tunnel sections.

The operational swing limit shall be a potentiometer located in the rotunda ceiling and shall be accessible from inside. It serves to provide three levels of safety for bridge swing (side-to-side) motion: 1. Text messages activate at the operator console as swing limits are reached. 2. Audible alarms sound at the operator console as ultimate swing limits are reached 3. Bridge motion is stopped when operational or ultimate swing limits are reached.

Should the bridge pass through the operational swing limits, the ultimate swing limit shall trip and stop bridge motion. The ultimate limit switch shall be normally set 2 to 3 degrees past the point where the operational limits are set. Should the ultimate swing limit be reached, maintenance personnel will be required to move the bridge.

a. The Corridor: The corridor shall be the interface between the rotunda and the terminal building or fixed passageway. The inside clear width of the corridor shall be 1334 mm or 4 ft. 4-1/2 inches. The clear height shall be 2311 mm or 7 ft. 7 in.

The design of the corridor shall accommodate installation of flexible exterior weather seals and interior metal flashing and floor thresholds.

b. The Rotunda: The rotunda floor remains stationary and level at all times and provides a smooth transition between the terminal and telescoping tunnels. Flap type seals provide weather protection between the rotunda and the hinged telescoping tunnel section.

c. The Support Column: The support column shall be the structural support for the PBB. The support column rests on a foundation that shall be supplied by others. The support column shall be custom built to meet specific site conditions. There shall be limited adjustment for height once the column shall be built.

The standard anchor bolt pattern for the Apron Drive PBB shall be pattern #7.

An electrical disconnect panel, mounted on the rotunda support column, provides the electrical disconnects, transformers – if required, and circuit breakers, as required, to adapt and distribute the specified, customer-provided 3 phase supply power to the various PBB electrical systems. The disconnect panel's heavy duty, stainless steel enclosure shall be a NEMA 4X (IP65) rated enclosure. The disconnect panel shall be equipped with an interior dead front door, accessible only with a tool or a key. This panel shall allow for the addition of multiple ancillary equipment options, such as PC Air and 400 Hertz, in a variety of power source options. It shall be possible, for instance, to provide a single power feed or separate power feeders into the disconnect panel.

2. The Telescoping Tunnels

a. The telescoping tunnels, A (smallest), B (mid-size on three tunnel PBBs, largest on two tunnel PBBs) and C (largest, three tunnel PBB only), shall be rectangular in cross section. Bridges shall be available in 2 tunnel or 3 tunnel configurations. The tunnels with the largest cross section shall be closest to the aircraft. The tunnel walls shall be constructed of 14 gauge steel corrugated plate.

b. Transition ramps shall accommodate the difference in elevation where telescoping tunnel sections overlap. The tunnel floor shall slope as it approaches the transition ramps to minimize the slope of the transition ramps. The transition ramps shall have a slope, with respect to the tunnel centerline, of approximately 3 degrees. Handrails shall be provided on both sides of the tunnel transition ramps.

c. Minimum interior clear dimensions for both A2 and A3 PBBs shall be as follows:

Minimum Floor Width	1473 mm or 4' - 10"
Minimum Interior Height	2134 mm or 7' - 0"
Minimum Inter-tunnel Ramp Width	1422 mm or 4' - 8"
Minimum Corridor Width	1334 mm or 4' - 4 1/2"

d. The telescoping tunnels shall be equipped with an exterior under-the-bridge-mounted electrical cable conveyance system. The cable system shall be accessible to maintenance personnel for inspection or cable changes at all bridge positions and operating conditions. Access to the cable conveyance system shall not impede passenger traffic or bridge operation. The cable conveyance system shall be capable of supporting a combination of cables and hoses. The system shall be capable of supporting a cross-sectional area totaling 7742 square mm or 12 square inches, which shall consist of 2 each 3871 square mm or 6 square inch areas.

The system shall be capable of supporting a combination of cables and hoses totaling 17.86 kg/m or 12 pounds per foot.

3. The Service Access

A service door, landing, and stair leading to the apron shall constitute the service access. The service access shall be located on the right hand side of the cab end of the PBB to provide access between the PBB bridgehead and apron for authorized personnel

a. The service door shall be steel, half wire-glass, hollow core, and meet or exceed the ¾ hour fire rating per ASTM E152. The minimum door shall be 762mm or 2 feet 6 inches wide and 2032 mm or 6 feet 8 inches high. The door shall be equipped with medium-duty commercial-type hardware and automatic door closure. The door opens outward onto the landing.

b. The service stair landing shall be parallel to the adjacent tunnel floor. It shall be made of hot dipped galvanized steel, open mesh grating. The landing shall be protected on the open sides by galvanized steel handrails which shall be designed to meet OSHA standards.

c. The service stair shall be equipped with self-adjusting risers and open mesh steel treads. All steps shall have an equal rise. The tread width shall be 711mm or 28 inches and the maximum tread depth shall be 241 mm or 9-1/2 inches. The service stair shall be protected on each side by handrails which shall be designed to meet OSHA standards. The entire service stair assembly shall be constructed from galvanized steel. The service stair shall be accessible to ramp service personnel at all operational heights and positions of the PBB.

d. An exterior rated 60 watt incandescent light fixture shall be provided on the exterior of the PBB above the service stair and landing to illuminate the service access. The light shall be controlled by a light switch provided on the interior wall of the PBB adjacent to the service stair access door.

4. The Control Station

The control station or operator compartment shall be located at the aircraft end of the PBB. It provides the operator with a control console, service utilities, and control interlocks required for PBB operation. The control station shall be positioned on the left side of the cab and oriented to position the operator facing forward in full view of the aircraft during bridge operations.

- a. The control console shall be located in the operator compartment and shall be protected from the outside environment.

The control console shall contain a Human Machine Interface (HMI) consisting of a graphical display providing the operator with control interfaces, bridge set up displays, maintenance / diagnostic information, wheel position information, and fault / limit / status messages as described in the following sections. PBB functions and information systems shall be controlled using a Programmable Logic Controller (PLC). The PLC system used shall comply with IEC 1131.

The PLC shall be designed to allow networking of the boarding bridges and appropriately equipped ancillary equipment, such as pre-conditioned air units and 400 Hertz converters, to a common remote monitoring station using Ethernet protocols and appropriate hardware.

The operator shall be able to select one of the optional preprogrammed languages for display on the HMI. English shall be the standard default language, unless otherwise specified. Up to three (3) additional languages can be programmed into the PLC as options. Once a language has been selected, all messages shall be displayed in the selected language until the current operating session is logged off. At log on, the default language shall return to the screen.

- b. Security. An Operator Key shall be required to access PBB operations or maintenance activities. Passwords, such as a maintenance password, shall be used to control access to bridge functions, set ups, maintenance and diagnostic screens. Other security and access options are available.

- c. Controls: All bridge motion controls shall be momentary, contact-type (deadman) pushbuttons or joystick. All of the motion controls shall be designed to be relative to the function of the PBB being controlled, i.e., raise and lower functions, the "raise" push button will be located above the "lower" push button.

- i. Operator Key Switch: A three position, master key switch shall be used to select "OFF", "OPERATE" or "AUTO" (automatic leveling). The key may be removed only in the "OFF" or "AUTO" positions.

- ii. Joystick: A lever arm or "joystick" controls horizontal motions: extend / retract and left / right. As the control stick is moved progressively from the neutral position, bridge speed increases proportionally with the position of the joystick. As an option, the bridge shall be capable of "Point and Go" steering. This shall mean that the bridge will move in the direction that the joystick is pointed regardless of the rotational position of the cab.

Control options are available allowing for other steering methods -- such as a combination of joystick and left / right steer buttons.

An interlock prevents the PBB from being driven forward when the aircraft closure shall be deployed.

iii. Manual Floor Adjustment: Push button switches for raising and lowering the cab end of the PBB.

iv. Cab Rotate: Push button switches for cab rotation, left or right

v. Canopy Closure: Push buttons for independent adjustment of the left and right side of the bellows-type aircraft closure.

vi. Emergency Stop: An emergency push button switch for discontinuing all bridge operations. This button shall be labeled "Stop".

vii. Preposition Button: A preposition move push button shall be used to engage the automatic pre-docking operation. Prepositioning means that the bridge can be automatically moved from its parked position to a pre-selected service position. Prepositioning includes rotation of the PBB to the correct service angle, extension of the PBB to the correct length, raising of the PBB to the correct pre-selected height, and rotation of the cab to a pre-selected rotational position. The aircraft-type selection options shall exist as part of the PBB software. Site-specific PBB positional information for the pre-positioning feature shall be field programmable.

5. Control Interfaces and Indicators

An Operator Key shall control the PBB operating mode. The three modes available from the Operator Key shall be "Auto" for Autolevel Mode, "Manual or Operate" for manual operation, and "Off" to discontinue bridge operations.

a. Autolevel: Turning the Operator Key to "Auto" shall initiate the autolevel sequence. The Autolevel arm extends toward the aircraft, and the system performs an automatic check of the Autolevel to verify that the aircraft sensor has made contact with the aircraft and that the Autolevel control system is functional. Upon completion of the verification process, a message shall be displayed indicating that the PBB is in Autolevel Mode.

When in the autolevel mode, the PBB shall be allowed only vertical travel. In autolevel mode, the PBB shall automatically follow the vertical movement of the parked aircraft.

To exit autolevel mode, the Key Switch shall be turned to the Off position or to Manual Mode.

Upon activation of the autolevel mode, the canopy, cab rotation and horizontal travel become inactive.

b. Manual Mode: Turning the Operator Key Switch to the Manual / Operate position enables all bridge movements – extend/retract, vertical, floor movement, and cab rotation – provided there are no faults or tripped limits. In the operate mode, all bridge movement shall be initiated by the operator. The appropriate pushbuttons shall be lighted to indicate those functions available, and a message on the HMI panel shall be displayed indicating the PBB is in Operate Mode.

An infrared sensor shall slow the bridge as it approaches the aircraft when in operate mode.

c. Off Mode: All PBB functions shall be disabled in the off mode, except lighting.

d. Cab Floor Auto/Manual: Depressing the Cab Floor Auto Manual button shall allow control of the cab floor to be toggled between the automatic and manual modes of operation. Indicator lights shall display which mode is active.

Upon selection of manual mode, two additional pushbuttons become active enabling the manual movement of the cab floor -- up or down. Touching the Up button shall move the right side of the cab floor in the up direction. Touching the Down button shall lower the right side of the cab floor.

When the Operator Key is in the Auto Level position, all cab floor movement shall be disabled. The Cab Floor mode of operation that was selected when the Auto Level mode of operation was energized shall be reactivated when the Auto Level mode is deactivated.

e. Canopy Actuation: The aircraft canopy closure shall be activated by depressing the Canopy Up or Down buttons. Canopy actuation shall be active only in Manual Mode. Therefore, the canopies must be deployed prior to entering autolevel mode. The left and right side canopy actuator motors shall be independently controlled by limit switches that sense both the pressure against the aircraft, and operational range limits to provide positioning of the canopy to the aircraft and prevent over extension or retraction of the canopy closures.

f. Floodlights: A console button shall be provided to allow control of the three apron floodlights that shall be located on the underside of the PBB. These floodlights shall be positioned to illuminate the apron for a distance of approximately 10 m or 30 feet forward of the PBB, and around the wheel carriage. Pushing the Floodlight button will toggle the apron flood lighting on and off.

g. Travel Bell: A momentary console button shall be provided to allow manual activation of the travel warning bell. When touched, the travel bell shall be activated until the button is released. (The travel warning bell sounds automatically when the PBB moving.)

h. Options: An Options button shall be available on the HMI to allow additional PBB features to be selected. These features may include selections such as floor heating, window heating, additional lighting, etc., and shall be dependent upon customer-selected options.

i. Indicators: The following indicators are present in both autolevel and manual operator key switch modes.

i. Vertical Height: The current vertical height of the aircraft measured from apron or ground level. The measurement shall be displayed in feet or meters depending on customer preference.

ii. Bridge Length: Bridge length shall be measured between the rotunda center line and the outer edge of the cab spacer. The status panel shall display the linear distance accurately regardless of the rotational position of the cab. The measurement shall be displayed in feet or meters depending on customer preference. Changing the display from feet to meters shall be accomplished by using a toggle touch switch located in the Options screen under the Maintenance/Set Up program.

iii. Rotational Angle: The rotational angle of the bridge shall be displayed. The zero data point shall be identified when the tunnel centerline shall be positioned parallel to the rotunda corridor centerline. The display identifies angular counterclockwise (left) rotation in positive (+) degrees, and clockwise (right) rotation in negative degrees from the centerline axis.

iv. Cab Rotation Angle: The zero data point shall be identified when the aircraft spacer shall be positioned perpendicular to the telescoping tunnel centerline. The display shall indicate counterclockwise (left) rotation in positive (+) degrees and clockwise (right) rotation in negative degrees from the centerline axis.

v. Wheel Position Angle: Zero degrees shall be identified when wheel carriage drive wheels shall be positioned parallel to bridge telescoping tunnel centerline axis. The display will indicate counterclockwise (left) rotation in positive (+) degrees and clockwise (right) rotation in negative degrees from the centerline axis.

NOTE: There are other indicators not located on the control console. These indicators are as follows:

vi. Flashing Travel Beacon: A flashing amber beacon shall be mounted under the cab. The beacon indicates that power shall be on and the bridge may move at any moment.

vii. Warning Bell: An audible warning bell shall be mounted under the bridge on the wheel carriage and rings (98 decibels at 10 ft. {3048mm}) when the bridge shall be moving horizontally.

j. The HMI Message Display: The HMI provides status and fault information to the operator. Standard HMI messages include the following:

ACF Floor Fault. Level Floor Manually
Autolevel Failure. Turn Key to OPERATE to reset
Cab Left Contactor Weld Fault. Call Maintenance
Cab Left Limit Reached. Rotate Cab Right
Cab Left Ultimate Activated. Call Maintenance
Cab Pot Failure. Call Maintenance
Cab Right Contactor Weld Fault. Call Maintenance
Cab Right Limit Reached. Rotate Cab Left
Cab Right Ultimate Activated. Call Maintenance
Docking Interlock – Please Wait (option sensitive message)

Extend Limit Reached. Retract Bridge
Extend Ultimate Limit Activated. Call Maintenance
Inverter Fault. Call Maintenance
Main Contactor Weld Fault. Call Maintenance

Retract Limit Reached. Extend Bridge

Retract Ultimate Limit Activated. Call Maintenance

Slope Down Limit Reached. Extend or Elevate Bridge
Slope Up Limit Reached. Extend or Lower Bridge
Swing Left Limit Reached. Drive Bridge Right

Swing Right Limit Reached. Drive Bridge Left
Swing Ultimate Limit Reached. Call Maintenance
Vertical Down Limit Reached. Elevate Bridge
Vertical Down Ultimate Limit Contacted. Call Maintenance

Vertical Down Contact Weld Fault. Call Maintenance
Vertical Drive Left Overload. Call Maintenance

Vertical Drive Right Overload. Call Maintenance
Vertical Rack. Call Maintenance
Vertical Up Contact Weld Fault. Call Maintenance
Vertical Up Limit Reached. Lower Bridge
Vertical Up Ultimate Limit Reached. Call Maintenance
Wing Root Contacted. Elevate Bridge

HMI Calibrations (Maintenance Password Required for Access)

Height Calibration
Extension Calibration
Wheel Bogie Angle Calibration
Vertical Up Limit Set
Vertical Down Limit Set
Cab Right Limit Set
Cab Left Limit Set
Swing Right Limit Set
Swing Left Limit Set
Extend Limit Set
Retract Limit Set
Change Password
Set Pre-positioning Points (optional)

Others as required by options

k. Prepositioning Move Button: The PBB shall be designed to allow three-axis pre-positioning. The operator can select one of the available pre-programmed aircraft types from the HMI Pre-Position Screen. The operator must depress the "Preposition Move" pushbutton and hold it down for bridge movement to occur and continue through the prepositioning travel. The PBB shall automatically rotate about the rotunda axis, extend to a pre-programmed length, elevate to a pre-determined height, and rotate the cab to a

pre-determined angle. This will allow docking of the PBB to an aircraft using the most direct route with a minimal amount of operator skill. If pressure against the Preposition Move switch shall be released at any time during the pre-positioning cycle, all bridge motion shall stop.

It is intended that the PBB will be prepositioned prior to aircraft arrival and that the PBB will be approximately 3m to 4m or 10 to 12 feet from the left side of the fuselage of the selected aircraft with the PBB fully oriented to allow a “straight” in dock for the operator.

The PBB shall be equipped with an infrared proximity sensor to automatically stop the PBB when it approaches within 2 meters or 6 feet of an aircraft while in the Pre-position mode of operation.

Final docking (approximately 3m to 4m or 10 to 12 feet of travel directly toward the aircraft door) with the aircraft shall be completed manually with the joystick controller.

Pre-positioning shall be easily programmed by local maintenance personnel without the use of ancillary programming devices from the HMI Maintenance Set-UP Screen.

I. Other Control Console Indicators

- i. An amber light indicates the auto-leveling system shall be energized and functioning.
- ii. A red light and audible warning indicates the autoleveler sustained travel timer has tripped.
- iii. A red light indicates the aircraft canopy shall be down. The canopy must be fully retracted before the PBB can be moved forward.
- iv. A message on the HMI and alarm indicate vertical drive column faults.

6. The Maintenance and Set-Up Screens

a. HMI Screens: The PBB shall be designed to provide a quick method for programming the PLC to accept new operational parameters. The Maintenance / Set-up Screens shall allow maintenance personnel to complete initial set-up or reprogramming of the PBB operational parameters directly from the PBB control console without the use of additional programming devices. These screens provide for Preposition and Location Set up, Status Calibration, and initial Bridge Operational Limit Set Up.

b. Prepositioning: Pre-positioning shall be easily programmed by local maintenance personnel without the use of ancillary programming devices. A maintenance person shall be required to log onto the PBB using a maintenance password. From the Maintenance Set-Up Screen located in the Setup Screen menu, the Pre-Position Set-up Mode of Operation shall be selected. The PBB shall then be rotated, moved vertically, extended, and the cab rotated to the desired aircraft service position. Upon reaching the desired aircraft service position, one of the preposition set-up buttons, labeled as specific aircraft types, shall be depressed to program the PLC with the required coordinates for that particular pre-positioning location. No other programming shall be required.

c. Status Calibration: The Status Calibration screen shall be provided to accommodate input of critical data used in establishing operational parameters for a particular gate location during the initial PBB set-up operation. The calibration includes the following data:

i. Feet/Meter Selection: A selection shall be provided to allow the linear measurements that shall be displayed on the main screen status display panel to be toggled providing either a Feet or Meter linear measurement read-out.

ii. Calibrate Height: The Calibrate Height sub-screen provides the ability to establish a vertical data point that shall be used as the base for calculation of the vertical height measurements displayed on the screen. Upon selection of this sub-screen, the operator must position the PBB to a level height. The vertical height between the apron and top of cab spacer shall then be physically measured and the data input into the PLC using the touch keys of the HMI panel.

iii. Calibrate Length: The Calibrate Length sub-screen shall provide the ability to establish a base data point that shall be used by the PLC to accurately identify the linear extended length of the PBB displayed on the screen. To calibrate the extension of the PBB, the operator must enter two data points, referred to as “far” and “near” extension points. Extend the PBB to the “far” point and measure this length from the Rotunda center point to the forward edge of the cab spacer. Then, enter this length using the appropriate touch keys. Next, retract the PBB to the second, or “near” point, and again measure this length as before. Enter this value. This completes the extension calibration.

iv. Bridge Limit Set-up: The Bridge Limit Set-up sub-screen shall be used to establish the specific gate operational limits of PBB movement. These limits include cab rotate right, cab rotate left, bridge swing left, bridge swing right, bridge extension, bridge retraction, vertical up, and vertical down limits. Moving the PBB to the desired limit of travel and touching the appropriate touch key completes the setup of each of these limits.

d. Log Off: To log off, the Operator Key shall be turned to the OFF position or push the OFF button on the HMI. This will return the HMI to the opening logon screen.

7. The Utilities

a. A high speed communication / networking cable consisting of 3 bundles of 4 pair each category five, 24 gauge communications cable shall be provided.

b. Utility outlets (unswitched 120 volt, 1 phase, 15 amp) shall be located on left wall of the cab, adjacent to the operator’s control console and in the rotunda corridor. An additional 15 amp GFI duplex outlet shall be provided on the drive column wheel carriage cross beam where it shall be accessible to maintenance personnel at ground level.

8. Control Features and Interlocks

a. Mechanical and logical interlocks shall be provided to prevent damage to control circuits or boarding bridge components by selecting opposite motions simultaneously. For example, depressing an “up” button prevents depressing a “down” button.

b. When the operator selects the Auto Level mode, or Logs Off the control system, all basic bridge operational controls shall be inoperative.

c. Basic functional logic of the PBB shall be programmed by the manufacturer. This logic resides in non-volatile memory.

The software acts upon PBB location sensor inputs and operator control inputs to provide valid PBB motions. If a conflict arises between operator inputs and sensor inputs, error routines shall be executed to display messages on the HMI, turn on warning lights, sound an alarm and/or stop the bridge as necessary.

PBB motions shall be protected by two levels of limits. First level limits provide warning to the operator and motion interruption. Motions selected by the operator that do not conflict with current limits shall be allowed. Other motions shall be disabled. Information suggesting allowable motions shall be displayed for the operator on the HMI.

A second level of limits prevents physical travel that may damage the PBB or endanger personnel. The limit devices interrupt the main line input power to all bridge control circuits except lighting. The PLC monitors the limit fault. The error and instructions shall be displayed on the HMI. Maintenance personnel shall be required to resolve the fault and reset the PLC to allow further PBB operation.

A motion-enable interlock shall require that an operator must initiate any bridge movement by activating a control panel switch. Otherwise, power cannot be applied to the energizing circuitry. As a result, if the PLC should command the bridge to move by sending an erroneous signal, the bridge will not move until a control console switch has been activated as well. Both the PLC command and the motion enable circuitry shall be activated prior to bridge movement.

9. The Aircraft Cab

a. The aircraft cab shall be designed to rotate 125 degrees. Rotation shall be 92-1/2 degrees counterclockwise and 32-1/2 degrees clockwise from the tunnel centerline.

b. The cab shall rotate at a speed of 145 degrees per minute (2.41°/sec). Limit switches and physical stops shall control the rotation limits.

c. The cab shall be equipped with a forward facing control console. The console shall be located behind a laminated safety glass window. Operation of the PBB can be accomplished without opening the cab weathering door. Additional visibility shall be obtained through the wire glass vision panels in the cab side-coiling-doors and windows located in front, left and right of the operator. The front window size shall be 813 mm x 610 mm or 2'8" x 2'. The left window size shall be 279 mm x 775 mm or 11" x 30-1/2". The right window shall be 813 mm x 152 mm or 2'8" x 6".

d. Double swinging weather doors shall be installed on the right side of the operators control console to secure the PBB from unauthorized access, and seal the interior of the PBB from adverse weather conditions when the door shall be closed. The minimum clear width of the weather door shall be 1101 mm or 43 3/8 inches, and the minimum door height shall be 2349mm or 7 foot 8 1/2 inches. The upper portion of each door shall be equipped with a 305 mm x 812 mm or 1 foot 0 inches wide x 2 foot 8" inches high safety glass

window to enhance visibility.

e. A full width spacer shall be located at the aircraft end of the cab floor. The spacer material, which meets the fire protection specifications of NFPA-415-1997, shall be sufficiently flexible and non-abrasive to prevent scratching or other damage to the aircraft fuselage.

f. The aircraft end of the cab shall be equipped with a cab floor that adjusts to level for various aircraft floor heights. The floor shall be individually actuated and independently adjustable to adapt to all narrow-body or larger aircraft doorsills. It shall be designed to level automatically and shall be equipped with a manual override control switch. The floor shall be capable of providing a level surface adjacent to the aircraft doorsill for PBB slopes from -10% to +10%. No portion of the cab floor shall exceed 8.33% slope in the direction of expected passenger traffic. The automatic leveling system corrects the floor to a slope not to exceed 0.5% (0.3°) after a threshold slope not to exceed 2% (1.2°) has been reached.

g. A double hinge floor shall be included in the system to provide a smooth transition between the level floor and the tunnel section. The transition floor provides a smooth platform.

The maximum slope of the floor shall be limited to plus or minus 6.5 degrees (11.4% or 1:8.78). There shall be no raised surfaces, which may introduce a tripping hazard to the passenger. Adjacent surfaces shall be at the same level regardless of the position of the cab floor or the PBB.

h. Two exterior floodlights shall be provided to illuminate the apron directly ahead of the PBB. A floodlight shall be provided to illuminate the drive column wheel carriage. This light shall be located under the tunnel section.

i. A weatherproof fluorescent fixture shall be provided outside the cab swinging weather door to illuminate the cab-aircraft interface.

10. The Aircraft Closure

The aircraft end of the cab shall be equipped with a folding bellows type aircraft closure. The closure, when fitted against the fuselage, shall surround both the open aircraft door and the doorway to protect passengers from the elements. The closure shall be designed to accommodate the special door requirements associated with A-300 type aircraft doors. The closure fabric will not absorb water, shall be highly tear resistant and remain flexible from -31 degrees F (-35 degrees C.) to 127 degrees F (52.8 degrees C.).

a. Each side of the aircraft closure shall be independently actuated to seal against aircraft contours.

b. Pressure sensitive switches shall be incorporated into the closure mechanism to prevent excessive pressure on the aircraft.

c. The contacting seal shall be a soft material to prevent scratching or damage to the aircraft skin. The seals that contact the aircraft shall be segmented and attached to the main closure assembly with Velcro type fastener strips for easy replacement.

11. Automatic Leveling

The PBB shall be equipped with an automatic leveling system. This system allows the PBB to follow the aircraft elevation changes that occur during aircraft loading and unloading. The auto leveling system functions with equal reliability for all aircraft contours. The autoleveler shall be located on the right side of the cab. The autoleveler shall be in full view of the operator at the control console. The autoleveler shall be engaged when the master key switch shall be positioned to "AUTO".

- a. The auto-leveler circuit includes a sustained travel timer. The timer limits autolevel operation to a maximum of six seconds; however, the timer shall be adjustable to accommodate a variable operational range of 1.6 to 6 seconds before a fault condition shall be identified. A fault condition shall be assumed if the operation exceeds the set time limit. Upon sensing of a fault condition, all motor power shall be disconnected and audible and visual alarms shall be energized.
- b. The main autolevel sensing switch shall be activated upon a 15-degree auto level wheel rotation

12. The Drive Column

The drive column provides the vertical and horizontal motion for the PBB. The drive column and control systems shall be designed for smooth, quiet operation. The vertical and horizontal movements can both be operated at the same time.

The drive column shall be divided into two major components: Vertical Drive and Horizontal Drive.

- a. Vertical Drive: The PBB shall be moved vertically by means of two recirculating ball bearing screw assemblies. Vertical travel speed is approximately 1097 mm or 3.6 feet per minute.
 - i. Each assembly shall be independent. Each independent assembly shall be capable of supporting the PBB under full design load. The design shall provide 100% redundancy.
 - ii. The ballscrew ball nut shall be equipped with wiper brushes to remove grit or dirt from the screw threads.
 - iii. The ballscrew ball nut shall be equipped with a special thread profile designed to be self-locking. This feature will support the PBB in the absence of the standard recirculating ball bearings.
 - iv. The vertical drive motors shall be AC induction motors with integral reducer and brake. The brakes shall be spring applied and electrically released. The brakes hold securely at all elevations whenever electrical power is not applied.
 - v. A fault detector senses differential motion of the ball screw assemblies. The detector disconnects electrical power from the vertical drive motors if a fault detected.
- b. Horizontal Drive: A variable speed, electro-mechanical drive system provides horizontal travel.

- i. The tires used on the horizontal drive system shall be aircraft grade pneumatic recapped tires. Other tire options are available, such as solid tires.
- ii. The AC horizontal drive system uses AC gear motors with integral brakes. The AC motors shall be driven by solid state, variable frequency motor controllers. The AC drive system shall provide high efficiency, smooth performance, and good component availability. The controller provides a variable frequency signal to provide adjustable speeds from 0 to 27.4 m or 90 feet per minute. The controller can be adjusted to provide optimum responsiveness to the horizontal controls. The controller provides built in diagnostics to assist with trouble shooting.
- iii. A steer angle of 180° shall be possible in place and in motion. Steering speed shall be adjustable between 16° and 42° per second. However, the steering rate shall be factory set at 23° per second.
- iv. A regenerative braking system shall be used allowing the PBB to come to smooth controlled stops. Integral spring-applied, electrically-released brakes shall be provided with each drive motor. The brakes lock the PBB in place when electrical power is disconnected. This shall occur when the joystick is in the neutral position or when normal operating power shall be discontinued.
- v. The horizontal drive motors shall be equipped with manual brake releases. These allow the PBB to be towed in the event of power failure. Tow lugs shall be a component of the lower wheel frame.
- vi. The horizontal drive wheel system shall be equipped with mechanical stops to prevent over steer. A wheel position potentiometer monitors rotational alignment with the bridge and provides operational wheel bogey limits. Wheel bogie position shall be indicated on the HMI.

13. Interior Finishes

The interior finish of the PBB shall be designed to be durable and easy to clean

- a. The ceiling shall be made of plank type panels. Each plank shall be 184 mm or 7 ¼ inches wide with a 19 mm or ¾ inch accent between adjacent planks. The planks run perpendicular to the tunnel centerline and continuously from wall to wall. The planks shall be manufactured from .51 mm or 020 inch thick aluminum, with a baked-on enamel finish. Planks located at the ends of light fixtures shall be painted black to match the fixtures.
- b. The interior light fixtures shall be designed to be the same width as the plank. The fixtures shall be recessed and blend with the ceiling design.
- c. Tunnel and rotunda interior lighting shall be provided by High Output, Energy Saving, Cool White, Single Lamp, Fluorescent Light Fixtures that are powered by instant start electronic ballast's that provide a 1.0 ballast factor. The average light intensity at the floor is 18 foot candles (194 lux). Please note that lighting intensity levels vary significantly with changes in interior color designs. The measurements noted above are based on an interior design that incorporates white wallboard with light colored carpeting and white ceiling.

- d. Three-way interior lighting control switches shall be provided at the ingress and egress points of the PBB with one switch located in the rotunda, and one on the wall near the service door at the aircraft end of the PBB. These switches control all interior tunnel, bubble, rotunda and cab floor light fixtures.
- e. The aluminum corner molding that finishes the ends of the ceiling plank and the top edge of the wall panels shall be black to match the interior light fixtures.
- f. Insulation in the ceiling shall be 12.7 mm or ½ inch, black, fire resistant fiberglass.
- g. The sub floor in the cab and bubble shall be 19 mm or ¾ inch marine grade plywood, which shall be highly resistant to moisture and moisture damage. The sub floor in the remainder of the bridge shall be 19 mm or ¾ inch thick American Plywood Association rated STURD-I-FLOOR Exposure 1. Exposure 1 panels shall be highly moisture resistant. Exposure 1 panels shall be made with exterior phenolic resin adhesive.
- h. Ribbed rubber, approximately 6 mm or ¼ inch thick, shall be applied to the floor from the aircraft end of the PBB to the terminal side of the service door.
- i. PBB interior floor coverings, can be furnished by the supplier or the customer and installed by either party depending upon customer preference.
- j. The tunnel interior wall shall consist of floor-to-ceiling, high-pressure laminate, phenolic and melamine plastic panels. The panels shall be approximately 1219 mm or 4 ft. on center and shall be supported by clear anodized aluminum trim with a black accent strip. The design allows each panel to be removed individually. The wall structure shall result in an average thermal resistance of 2.6 Ft²oF/BTU (4.5 m²oC/W).
- k. The walls of the rotunda pivoting section shall be constructed using a series of 63.5 mm or 2.5 inch wide, formed galvanized steel slats that shall be connected together to develop a coiling curtain assembly.
- l. Wall treatment in the cab pivoting section shall be galvanized steel slats.
- m. Interior surfaces and trim exposed to passenger flow shall be painted to meet the customer defined interior color scheme per the following process:

Non Exposed Surfaces:

Surface Preparation

All contaminants shall be removed from the surface in accordance with SSPC-SP1 (Solvent Wipe) requirements and commentaries.

The surface shall be then cleaned in accordance with SSPC SP-3 (Mechanical Cleaning) requirements.

Primer:

One coat of Sherwin-Williams rust inhibitive, "Chromate Free" Kem Aqua 70P (Grey E61A570) primer shall be applied at a dry film thickness of 1.1 mils (27 microns).

Interior Exposed Surfaces:

Surface Preparation:

All contaminants shall be removed from the surface in accordance with SPC-SP1 (Solvent Wipe) requirements and commentaries.

The surface shall be then cleaned in accordance with SSPC SP-3 (Mechanical Cleaning) requirement to obtain a 1-4 mil profile. The cab surface shall be dry abrasive blast cleaned in accordance with SSPC-SP 6 (Commercial Blast Cleaning) to obtain a blast profile of 1-4 mils (25-100 microns).

Primer Coat:

One coat of Sherwin-Williams High Build "Chromate Free" Epoxy primer E65AC8/E65RC5 shall be applied over the prepared surface to a dry film thickness of 2-5 mils (50-125 microns).

Finish Coat:

One single color finish coat of Sherwin-William "Polane H" pigmented Polyurethane shall be applied over the primer coat at a dry film thickness of 2-3 mils (50-75 microns). The color shall be selected by the customer.

Roller Flange Protection:

The structural steel flange bars that shall be exposed to roller loading shall be coated with soft graphite impregnated paint. This process produces a roller interface surface that resists cracking and peeling, and absorbs the roller loads while maintaining the corrosion protection and aesthetic appearance of the PBB.

14. Exterior Finishes

All exterior steel surfaces shall be protected from corrosion by the following processes:

Surface Preparation:

All contaminants shall be removed from the surface in accordance with SSPC-SP1 (Solvent Wipe) requirements and commentaries.

The surface shall be then dry abrasive blast cleaned in accordance with SSPC SP-6 (Commercial Blast Cleaning) requirement to obtain a 1-3 mil profile.

Primer:

One coat of Sherwin-Williams High Build Chromate Free Epoxy Primer E65 AC8/E65RC5 shall be applied over the prepared surface to a dry film thickness of 3-17 mils (75-425 microns).

Finish Coat:

One single color finish coat of Sherwin-William Polane (aliphatic) high solids, catalyzed, pigmented Polyurethane shall be applied over the primer coat at a dry film thickness of 2-3 mils (50-75 microns). The color shall be selected by the customer.

The total exterior finish will provide a minimum dry film thickness of 6 mils (150 microns).

16. Miscellaneous Parts

Surface Preparation

All surfaces shall be dry abrasive blast cleaned in accordance with SSPC SP-6 to obtain a .5 - 1.5 mil (12-38 micron) profile.

Finish Coat:

One coat of Morton International Corvel Zinc Rich, Grey Epoxy Powder 13-7004 baked at 350°F for 35 minutes to obtain a dry film thickness of 3-5 mils (75-100 microns).

C. Design Criteria

The PBB shall be designed in accordance with good engineering practices and the standards developed and adopted by the passenger boarding bridge industry. Particular attention shall be given to keeping components simple, rugged and easily accessible for routine maintenance, including lubrication, component exchange and ease of adjustment.

All access panels and openings shall be sized to accommodate the component being changed or adjusted, as well as the equipment and personnel necessary to accomplish the work.

1. Structural Loads

a. The PBB will support the following loads. These loads may be applied in total or in part, singularly or simultaneously. The design shall be based on the combination, which imposes the most adverse loading. In addition to the dead loads and strain caused by movement, the entire PBB will support:

i. Live load of 40 lbs per sq ft (195 kg/sq M)

ii. A wind load of: Retracted and stowed -- 25 lbs per sq ft (122 kg per sq M), or an approximate wind velocity of 98 mph (158 km per hr). An operational wind load of 12.5 lbs per sq ft (61 kg per sq M) or an approximate wind velocity of 70 mph (113 km per hr).

iii. A roof load of 25 lbs per sq ft (122 kg per sq M).

iv. The structural design provides sufficient torsional rigidity to avoid excessive sway when the PBB shall be brought to a gradual stop.

v. All mechanisms for actuating, guiding and restraining the PBB and its

components shall be designed so that no noise, sway, or sense of insecurity shall be apparent to passengers. No operating vibrations or loads shall be transmitted to the terminal building.

2. Environmental Considerations

- a. The PBB will operate satisfactorily under ambient temperature conditions of -25 degrees F (-32 degrees C) to 125 degrees F (52 degrees C), with wind up to 60 mph (97 kph).
- b. All components and materials shall be individually and collectively designed or selected for long service life under such conditions.

3. Power Characteristics

- a. The PBB operates on 480 volts, 3 phase, 60 amps, 60 Hz "Y" configuration with neutral and separate ground (5 wire). The 480 VAC shall be transformed to 120/230 VAC for lighting and controls. Please note that other voltages found throughout the world can be accommodated.

4. Codes and Regulations

The PBB shall be designed to meet U.S. Codes and Regulations, which have been adopted by the passenger boarding bridge industry.

a. Structural

American Institute of Steel Construction (ASHALL BEC) Specifications for the Design, Fabrication and Erection of Structural Steel for Buildings.

American Welding Society (AWS) Standards.

Structural Design and Corrugated Steel Panels based on Van Karmon Theory and on buckling studies by Peterson and Card.

b. Material

Structural Steel ASTM-A36

Structural Tube and Shapes ASTM-A500

Steel Pipe ASTM-A53

Steel Sheet ASTM-A570

T-1 Steel ASTM-A514 & A517

Hinge Pins ASTM - A 311 Grade 1018 & Grade 1144

Bolts - High Strength SAE-J429 GRADE 5 and 8 or ASTM - A 325 and A490

- c. Mechanical: All mechanical components and designs conform to the recommendations and standards established by the Society of Automotive Engineers (SAE) and the American Society of Mechanical Engineers (ASME).

- d. Fire Protection: The PBB meets the requirements of the National Fire Protection

Association (NFPA) and is listed for compliance with the “Standard on Construction and Protection of Aircraft Loading Walkways”, NFPA-415-1997 by ETL, a Nationally Recognized Testing Laboratory (NRTL).

e. Electrical: All equipment and methods of installation conform, where applicable, to the requirements and recommendations of the National Electrical Manufacturers Association (NEMA) and the National Electrical Code (NEC) latest issue.

The PBB shall be listed in the United States and Canada by ETL, a Nationally Recognized Testing Laboratory (NRTL.) for compliance with:

UL 325 Third Edition: Standard for Door, Drapery, Gate, Louver, and Window Operators and Systems.

CSA/C22.2-2471992: Standard for Door, Drapery, Gate, Louver, and Window Operators and Systems.

NFPA 415-1997: Standard on Construction and Protection of Aircraft Loading Walkways.

D. Manuals and Training

1. Operation and Maintenance Manuals

That follow the intent of the Air Transport Association (ATA) Specification 101 shall be provided as outlined below. Included in the manuals shall be preventative maintenance requirements and problem solving procedures.

a. Manuals shall be furnished according to the following schedule:

- One PBB - Three Operation and Maintenance Manuals.
- Two PBBs - Four Operation and Maintenance Manuals.
- Three PBBs - Five Operation and Maintenance Manuals
- Four PBBs - Six Operation and Maintenance Manuals
- Five or More PBBs - Six Operation and Maintenance Manuals. Additional manuals may be purchased through your Jetway® Systems representative.

2. PBB Operator Training

Training shall be provided at scheduled times during the installation

E. WARRANTY

A. SELLER warrants only that its products when shipped and its work when performed will meet all applicable specifications and other specific product and work requirements (including those of performance, if any) of this agreement and will be free from defects in material and workmanship. All claims under this warranty must be made in writing immediately upon discovery and in any event within one (1) year from acceptance of the applicable product (or 18 months from shipment of the product, whichever shall be earlier) or one (1) year from completion of the applicable work if work shall be involved. Defective and nonconforming items must be held for SELLER'S inspection and returned to the original f.o.b. point upon request. The foregoing shall be expressly in lieu of all other warranties whatsoever, express, implied, and statutory, including, without limitation, the implied warranties of merchantability and fitness.

B. Upon BUYER'S submission of a claim as provided above and following its substantiation, SELLER shall at its option either (1) repair or replace its product or work at the final delivery point or (ii) refund an equitable portion of the purchase price.

C. The foregoing shall be SELLER'S only obligation and BUYER'S exclusive remedy for breach of warranty against SELLER for claims arising hereunder or relating hereto. In no event shall BUYER be entitled to incidental or consequential damages. Any action by BUYER arising hereunder, or relating hereto whether based on breach of contract, tort (including negligence and strict liability) or other theories must be discovered within one (1) year after the cause of action occurs or it shall be barred.

D. Failure caused by: (a) BUYER'S abuse (b) acts of God, which shall include but not be limited to hurricanes, earthquakes, and natural disasters shall be specifically excluded from the coverage of this section.

E. SELLER disclaims any warranty responsibility as to its product in the event of any modification of such product without prior written consent of SELLER.

F. The foregoing warranty provisions shall be applicable only if the BUYER has performed preventative maintenance in accordance with SELLER'S maintenance manual. The required maintenance must be performed and records maintained for SELLER'S review and inspection if requested.

OFFICE OF THE SECRETARY OF STATE
OF THE STATE OF COLORADO

CERTIFICATE

I, Wayne W. Williams, as the Secretary of State of the State of Colorado, hereby certify that, according to the records of this office,

John Bean Technologies Corporation

is an entity formed or registered under the law of **Delaware** has complied with all applicable requirements of this office, and is in good standing with this office. This entity has been assigned entity identification number 20081426823.

This certificate reflects facts established or disclosed by documents delivered to this office on paper through 05/28/2015 that have been posted, and by documents delivered to this office electronically through 06/01/2015 @ 11:52:44.

I have affixed hereto the Great Seal of the State of Colorado and duly generated, executed, authenticated, issued, delivered and communicated this official certificate at Denver, Colorado on 06/01/2015 @ 11:52:44 pursuant to and in accordance with applicable law. This certificate is assigned Confirmation Number 9205049.



A handwritten signature in blue ink that reads "Wayne W. Williams".

Secretary of State of the State of Colorado

*****End of Certificate*****

Notice: A certificate issued electronically from the Colorado Secretary of State's Web site is fully and immediately valid and effective. However, as an option, the issuance and validity of a certificate obtained electronically may be established by visiting the Certificate Confirmation Page of the Secretary of State's Web site, <http://www.sos.state.co.us/biz/CertificateSearchCriteria.do> entering the certificate's confirmation number displayed on the certificate, and following the instructions displayed. Confirming the issuance of a certificate is merely optional and is not necessary to the valid and effective issuance of a certificate. For more information, visit our Web site, <http://www.sos.state.co.us/> click Business Center and select "Frequently Asked Questions."



Greenprint Denver Vendor Sustainability

JBT Corporation is committed to sustainability and Corporate Social Responsibility (CSR), with this commitment extending both inside and outside our product solutions and into the many communities where JBT and its products operate. In addition, JBT is committed to the health and safety of our employees, facilities and surrounding communities and operates a rigorous and state-of-the-art Health, Safety and Environmental (HSE) program across the corporation.

JBT Corporation's product and service offerings drive improvements in the safety, efficiency, productivity and environmental impact of our customers' operations and support their CSR programs. Our commitment also takes us out to help others in the communities where we live and work.

At JBT, CSR boils down to this: thriving as a business by contributing to the success and sustainability of our customers, our communities and our world.

A few examples of recent process successes at JBT sites include:

- 26% energy consumption reduction. JBT's Automated Guided Vehicle (AGV) plant in Chalfont, PA, has undertaken multiple business initiatives to reduce their electricity and gas usage.
- Water usage reduction of 65%. JBT FoodTech's Lakeland, FL and Riverside, CA, facilities, installed closed loop water chiller technology that eliminated waste water discharge and reduced water consumption.
- 33% reduction of volatile organic compound and hazardous air pollutant emissions. JBT AeroTech Orlando's innovative process change reduced their usage of primer coatings in certain applications, cutting the facility's emissions.
- 80% reduction in cleaning agent use. JBT FoodTech's Sint Niklaas, Belgium facility has pursued a comprehensive CSR strategy which has included the usage of renewable energy, retrofits lighting, energy-efficient roofing, rainwater collection and utilization of environmentally friendly cleaning materials.

As a major global manufacturing corporation, JBT has maintained an extremely strong commitment to the health and safety of our employees and the surrounding communities for many decades. Maintaining outstanding Health, Safety and Environment (HSE) performance is a core value of JBT Corporation and JBT AeroTech. Our successful HSE performance has been made possible through the leadership and teamwork of all employees. The JBT Corporation's HSE Management System is based on the continual improvement process of the Plan-Do-Check-Act cycle utilized by such



global standards as ISO 14001, for environmental management, and OHSAS 18001, for safety management. The management system is the basis for all site HSE process/program development and the Corporate HSE Audit program.

At JBT's Jetway facilities we are undertaking a project to move ahead of EPA requirements and replace diesel generator sets with zero-emissions solid state power conversion technology in our test facility for pre-conditioned air units and other equipment. Use of such generators has not yet been restricted by mandate but JBT Jetway is moved ahead in support of our CSR program.

Virtually all steel – which makes up the bulk of the total mass of Jetway PBBs – as well as copper in the electrical systems incorporate some recycled content today. We are in discussions with suppliers to define and increase the recycled content so that it becomes a consistent and well defined portion of all Jetway products. If specified, additional recycled content can be included in a particular customer specification. For example, Shaw Industries is a major floor covering supplier to JBT Jetway and boasts a world-class sustainability program. Their design philosophy goes beyond cradle to grave and instead covers "Cradle to CradleSM", taking into account full recyclability of their products. JBT is pleased to offer Shaw carpets where specified.

Jetway also offers features and options to increase energy efficiency of its PBBs:

- LED lighting systems, both interior and exterior
- Daylighting (glass walls)
- Energy conserving controls for lighting and HVAC
- Integration of controls with a Building Management System (BMS)
- Energy efficient HVAC systems

JBT Jetway in Ogden, Utah is the most "local" PBB supplier to DIA. This minimizes the transportation impact and carbon footprint for delivery of equipment as well as travel of personnel for installation and future support.

Jetway PBBs are proven to have very long operational lifetimes, forestalling the eventual end of life considerations. The best conservation of resources is a long useful life as it avoids the highly consumptive need to manufacture a replacement. Since the beginning, Jetway has also extended the lifetimes of its PBBs by offering refurbishment services when required. At the eventual end of life the Jetway bridges are highly recyclable. At least 90% of the PBB by mass is fully recyclable steel and copper. Jetway's proven electro-mechanical drive systems eliminate any hazardous hydraulic oils that otherwise would have to be disposed of both during and at the end of the life of each PBB.



DENVER
THE MILE HIGH CITY

Office of Human Resources
Denver's Human Resource Agency

201 W. Colfax, Department 412
Denver, CO 80202
p: 720.913.5751
f: 720.913.5720
www.denvergov.org/csa

TO: All Users of the City of Denver Prevailing Wage Schedules
FROM: Seth Duhon-Thornton, Associate Human Resources Professional
DATE: Friday March 27, 2015
SUBJECT: Latest Change to Prevailing Wage Schedules

Please be advised, prevailing wage rates for some building, heavy, and highway construction trades have not been updated by the United States Department of Labor (DOL) since March 1, 2002. The Career Service Board, in their meeting held on April 21, 2011, approved the use of the attached supplemental wage rates until prevailing wage rates for these classifications of work are again published by the United States Department of Labor in accordance with the Davis-Bacon Act. The rates will be provided as a supplemental to the Davis-Bacon Building rates issued by OHR.

The attached Prevailing Wage Schedule is effective as of **Friday March 27, 2015** and applies to the City and County of Denver for **BUILDING CONSTRUCTION PROJECTS** (does not include residential construction consisting of single family homes and apartments up to and including 4 stories) in accordance with the Denver Revised Municipal Code, Section 20-76(c).

General Wage Decision No. CO150004
Superseded General Decision No. CO20140004
Modification No.02
Publication Date: 3/20/2015
(5 pages)

Unless otherwise specified in this document, apprentices shall be permitted only if they are employed pursuant to, and individually registered in, a bona fide apprenticeship program registered with the U.S. Department of Labor (DOL). The employer and the individual apprentice must be registered in a program, which has received prior approval, by the DOL. Any employer, who employs an apprentice and is found to be in violation of this provision, shall be required to pay said apprentice the full journeyman scale.

For questions call (720) 913-5018

Attachments as listed above.

General Decision Number: CO150004 03/20/2015 CO4

Superseded General Decision Number: CO20140004

State: Colorado

Construction Type: Building

County: Denver County in Colorado.

BUILDING CONSTRUCTION PROJECTS (does not include residential construction consisting of single family homes and apartments up to and including 4 stories)

Note: Executive Order (EO) 13658 establishes an hourly minimum wage of \$10.10 for 2015 that applies to all contracts subject to the Davis-Bacon Act for which the solicitation is issued on or after January 1, 2015. If this contract is covered by the EO, the contractor must pay all workers in any classification listed on this wage determination at least \$10.10 (or the applicable wage rate listed on this wage determination, if it is higher) for all hours spent performing on the contract. The EO minimum wage rate will be adjusted annually. Additional information on contractor requirements and worker protections under the EO is available at www.dol.gov/whd/govcontracts.

Modification Number	Publication Date
0	01/02/2015
1	01/09/2015
2	03/20/2015

ASBE0028-001 10/01/2013

	Rates	Fringes
Asbestos Workers/Insulator (Includes application of all insulating materials, protective coverings, coatings and finishings to all types of mechanical systems).....	\$ 28.83	13.18

BRCO0007-001 01/01/2014

	Rates	Fringes
BRICKLAYER.....	\$ 24.03	8.63

BRCO0007-005 05/01/2014

	Rates	Fringes
TILE SETTER.....	\$ 27.15	7.88

CARP0001-004 05/01/2013

	Rates	Fringes
Carpenters:		
Acoustical, Drywall		
Hanging/Framing and Metal		
Stud, Form Building/Setting.	\$ 25.00	5.39

 CARP1607-002 06/01/2012

	Rates	Fringes
MILLWRIGHT.....	\$ 28.95	11.10

 ELEC0068-002 06/01/2014

	Rates	Fringes
ELECTRICIAN		
(Includes Low Voltage		
Wiring and Installation of		
Fire alarms, Security		
Systems, Telephones,		
Computers and Temperature		
Controls).....	\$ 32.65	12.70

 ELEV0025-002 01/01/2015

	Rates	Fringes
Elevator Constructor.....	\$ 40.68	28.385+a+b

FOOTNOTE:
 a. Vacation: 6%/under 5 years based on regular hourly rate for all hours worked. 8%/over 5 years based on regular hourly rate for all hours worked.
 b. PAID HOLIDAYS: New Year's Day; Memorial Day; Independence Day; Labor Day; Veterans' Day; Thanksgiving Day; the Friday after Thanksgiving Day; and Christmas Day.

 ENGI0009-003 10/23/2013

	Rates	Fringes
Power equipment operator - crane		
141 tons and over.....	\$ 25.97	9.15
50 tons and under.....	\$ 24.88	9.15
51 to 90 tons.....	\$ 25.04	9.15
91 to 140 tons.....	\$ 25.19	9.15

 IRON0024-001 11/01/2013

	Rates	Fringes
IRONWORKER, STRUCTURAL.....	\$ 24.80	10.14

LABO0720-003 05/01/2014

	Rates	Fringes
LABORER		
Concrete/Mason Tenders.....	\$ 16.42	6.38

* PAIN0079-002 03/01/2015

	Rates	Fringes
Drywall Finisher/Taper		
Hand.....	\$ 20.15	6.91
Tool.....	\$ 20.50	6.91
Painters:.....	\$ 19.45	6.91
PAPERHANGER.....	\$ 20.15	6.91

PAIN0930-001 07/01/2014

	Rates	Fringes
GLAZIER.....	\$ 29.67	7.52

PLAS0577-001 05/01/2014

	Rates	Fringes
CEMENT MASON/CONCRETE FINISHER...	\$ 24.00	10.23

PLUM0003-001 07/01/2014

	Rates	Fringes
PLUMBER		
(Excluding HVAC work).....	\$ 31.93	12.34

PLUM0208-001 07/01/2013

	Rates	Fringes
PIPEFITTER		
(Including HVAC pipe).....	\$ 33.35	12.27

SFCO0669-001 07/01/2013

	Rates	Fringes
SPRINKLER FITTER.....	\$ 33.09	18.60

SHEE0009-001 07/01/2014

	Rates	Fringes
Sheet metal worker		
(Includes HVAC duct and installation of HVAC		

systems).....\$ 32.47 13.98

SUCO2001-011 12/20/2001

	Rates	Fringes
Carpenters:		
All Other Work.....	\$ 16.12	2.84
Ironworkers:		
Reinforcing.....	\$ 18.49	3.87
Laborers:		
Brick Finisher/Tender.....	\$ 12.78	1.41
Common.....	\$ 10.62	2.09
Power equipment operators:		
Mechanic.....	\$ 18.48	

WELDERS - Receive rate prescribed for craft performing
operation to which welding is incidental.

Office of Human Resources
Supplemental to the Davis-Bacon *Building* Construction Project rates
(Specific to the Denver projects)
Supp #100, Date: 03-02-2012

Classification		Base	Fringe
Boilermakers		\$30.97	\$21.45
Power Equipment Operators (Concrete Mixers):			
	Less than 1 yd	\$23.67	\$10.67
	1 yd and over	\$23.82	\$10.68
	Drillers	\$23.97	\$10.70
	Loaders over 6 cu yd	\$23.82	\$10.68
	Oilers	\$22.97	\$10.70
Soft Floor Layers		\$16.70	\$9.81
Ironworkers (Ornamental)		\$24.80	\$10.03
Plasters		\$24.60	\$12.11
Plaster Tenders		\$10.79	-
Laborers: Concrete Saw		\$13.89	-
Power Equipment Operators:			
	Backhoe	\$23.67	\$10.67
	Loader up to and incl 6 cu yd	\$23.67	\$10.67
	Motor Grader	\$23.97	\$10.70
	Roller	\$23.67	\$10.67
Truck Drivers (Dump Trucks):			
	6 to 14 cu yds	\$19.14	\$10.07
	15 to 29 cu yds	\$19.48	\$10.11
	Flatbed	\$19.14	\$10.07
	Semi	\$19.48	\$10.11

- To determine the Tile Setters-Marble Mason-Terrazzo mechanic rates—Use Davis Bacon-Building rates adopted by the Career Service Board.
- To determine the Tile Finisher-Floor Grinder-Base Grinder—Use current Career Service Prevailing Wage Schedules.
- Caulkers—Receive rate prescribed for craft performing operation to which caulking is incidental .i.e. glazier, painter, brick layer, cement mason.
- Use the “Carpenters—All Other Work” rates published by the federal Davis Bacon rates for batt insulation, pre-stress concrete and tilt up concrete walls, Roofers (including foundation waterproofing).
- Use the “Laborer—Common”, rates published by the federal Davis Bacon rates for General Housekeeping, Final Cleanup and Fence Installer.