

Master Purchase Order

DO NOT INVOICE TO THIS ADDRESS		Master Purchase Order No.	0578A0115		
City & County of Denver		Date:	August 26, 2015	Revision No.	
Purchasing Division		Payment Terms	Net 30	Ordinance (as applicable):	
201 West Colfax Avenue, Dept. 304		Freight Terms	DESTINATION		
Denver, CO 80202		Ship Via	Vendor's choice		
United States		Buyer:	Melissa Bordwine		
Phone: 720-913-8100 Fax: 720-913-8101		Phone:	720-913-8114		

PS Vendor ID: 0000095245 Phone: 800-424-0422 Fax: 704-878-0734 Email: kclark@toter.com

Toter, LLC.
841 Meacham Road
Statesville, NC 28677
Attn: Kellie Clark

Ship To: See Exhibit A

Bill To: Accounts Payable
201 West Colfax Department 908
Denver, Colorado 80202

1. Goods/Services:

Toter, LLC., a single member LLC located in the state of North Carolina, (“Vendor”) shall provide the goods, and any services related thereto, identified and described on attached **Exhibit A**, to the City and County of Denver, a Colorado municipal corporation (the “City”), all in accordance with the terms and conditions of this Master Purchase Order.

2. Ordering:

The City shall purchase one or more of the goods/services by issuing a written purchase order(s) or similar appropriate written document (“Order”), each of which will be deemed incorporated into this Agreement for purposes of such Order only.

3. Pricing:

The pricing/rates for the goods/services is contained on **Exhibit A** and shall be held firm for the term of this Master Purchase Order.

4. Extension or Renewal:

The effective period of this Master Purchase Order shall be one year from date of City signature. It is also a specific provision of this Master Purchase Order that the City and the vendor may mutually agree to renew and continue the contract or agreement consummated under this Master Purchase Order for additional periods of one year at the same prices, terms and conditions. However, no more than four (4) yearly extensions shall be made to the original Master Purchase Order.

5. Non-Exclusive:

This Master Purchase Order is non-exclusive. City does not guarantee any minimum purchase other than as provided herein.

6. Inspection and Acceptance:

City may inspect all goods/services prior to acceptance. Payment does not constitute acceptance. Vendor shall bear the cost of any inspection/testing that reveal goods/services that are defective or do not meet specifications. City’s failure to accept or reject goods/services shall not relieve Vendor from its responsibility for such goods/services that are defective or do not meet specifications nor impose liability on City for such goods/services. If any part of the goods/services are not acceptable to City, City may, in addition to any other rights it may have at law or in equity: (1) make a warranty claim; (2) repair and/or replace the goods or substitute other services at Vendor’s expense; or (3) reject and return the goods at Vendor’s cost and/or reject the services at Vendor’s expense for full credit. Any rejected goods/services are not to be replaced without written authorization from City, and any such replacement shall be on the same terms and conditions contained in this Master Purchase Order. Vendor shall perform all services in accordance with the standard of care exercised by highly competent vendors who perform like or similar services.

7. Shipping, Taxes and Other Credits and Charges:

All pricing is F.O.B. destination unless otherwise specified. Shipments must be marked with Vendor’s name, the Master Purchase Order number, and contain a delivery or packing slip. Vendor shall not impose any charges for boxing, crating, parcel post, insurance, handling, freight, express or other similar charges or fees. Vendor shall notify City in writing of any price decreases immediately, and City shall receive the benefit thereof on all unshipped items. Vendor shall comply with any additional delivery terms specified herein. Vendor shall be responsible for the cleanup and reporting of any contamination (environmental or otherwise) or spillage resulting from the delivery and/or unloading of goods within twenty-four (24) hours of the contamination or spillage or sooner if required by law. Vendor shall procure all permits and licenses; pay all charges, taxes and fees; and give all notices necessary and incidental to the fulfillment of this Master Purchase Order and all cost thereof have been included in the prices contained herein. City shall not be liable for the payment of taxes, late charges or penalties of any nature, except as required by D.R.M.C. § 20-107, et seq. The price of all goods/services shall reflect all applicable tax exemptions. City’s Federal Registration No. is 84-6000580 and its State Registration No. is 98-02890. Vendor shall pay all sales and use taxes levied by City on any tangible personal property built into the goods/services. Vendor shall obtain a Certificate of Exemption from the State of Colorado Department of Revenue prior to the purchase of any materials to be built into the goods/services and provide a copy of the Certificate to City prior to final payment.

8. Risk of Loss:

Vendor shall bear the risk of loss, injury or destruction of goods prior to delivery to City. Loss, injury or destruction shall not release Vendor from any obligation hereunder.

9. Invoice:

Each invoice shall include: (i) the Purchase Order number; (ii) individual itemization of the goods/services; (iii) per unit price, extended and totaled; (iv) quantity ordered, back ordered and shipped; (v) an invoice number and date; (vi) ordering department's name and "ship to" address; and (vii) agreed upon payment terms set forth herein.

10. Payment:

Payment shall be subject to City's Prompt Payment Ordinance D.R.M.C. § 20-107, et-seq. after City accepts the goods/services. Any other provision of this Agreement notwithstanding, in no event shall the City be liable for aggregate payments under this Master Purchase Order in excess of Seven Million Dollars (\$7,000,000.00). This Master Purchase Order is valid up to \$499,999.99. The balance is subject to City Council Approval. The Vendor acknowledges that any goods/services provided beyond those specifically described in **Exhibit A** are performed at Contractor's risk and without authorization from the City. City's payment obligations hereunder, whether direct or contingent, shall extend only to funds appropriated by the Denver City Council for the purpose of this Master Purchase Order, encumbered by the City after receipt of Vendor's invoice and paid into the Treasury of City. Vendor acknowledges that: (i) City does not by this Master Purchase Order, irrevocably pledge present cash reserves for payments in future fiscal years; and (ii) this Master Purchase Order is not intended to create a multiple-fiscal year direct or indirect debt or financial obligation of City. City may offset against any payments due to Vendor any claims and/or credits it may have against Vendor under this Master Purchase Order.

11. Amendments/Changes:

Only the Manager of General Services or his delegate is authorized to change or amend this Master Purchase Order by a formal written change order. Any change or amendment that would cause the aggregate payable under this Master Purchase Order to exceed the amount appropriated and encumbered for this Master Purchase Order is expressly prohibited and of no effect. Vendor shall verify that the amount appropriated and encumbered is sufficient to cover any increase in cost due to changes or amendments. Goods/services provided without such verification are provided at Vendor's risk. The Vendor has no authority to bind City on any contractual matters.

12. Warranty:

Vendor warrants and guarantees to City that all goods furnished under this Master Purchase Order are free from defects in workmanship and materials, are merchantable, and fit for the purposes for which they are to be used. For any goods furnished under this Master Purchase Order which become defective within twelve (12) months (unless otherwise specified) after date of receipt by City, Vendor shall either, at City's election and to City's satisfaction, remedy any and all defects or replace the defective goods at no expense to City within seven (7) days of receipt of the defective goods or accept the defective goods for full credit and payment of any return shipping charges. Vendor shall be fully responsible for any and all warranty work, regardless of third party warranty coverage. Vendor shall furnish additional or replacement parts at the same prices, conditions and specifications delineated herein.

13. Indemnification/Limitation of Liability:

Vendor shall indemnify and hold harmless City (including but not limited to its employees, elected and appointed officials, agents and representatives) against any and all losses (including without limitation, loss of use and costs of cover), liability, damage, claims, demands, actions and/or proceedings and all costs and expenses connected therewith (including without limitation attorneys' fees) that arise out of or relate to any claim of infringement of patent, trademark, copyright, trade secret or other intellectual property right related to this Master Purchase Order or that are caused by or the result of any act or omission of Vendor, its agents, suppliers, employees, or representatives. Vendor's obligation shall not apply to any liability or damages which result solely from the negligence of City. City shall not be liable for any consequential, incidental, indirect, special, reliance, or punitive damages or for any lost profits or revenues, regardless of the legal theory under which such liability is asserted. In no event shall City's aggregate liability exceed the agreed upon cost for those goods/services that have been accepted by City under this Master Purchase Order. Notwithstanding anything contained in this Master Purchase Order to the contrary, City in no way limits or waives the rights, immunities and protections provided by C.R.S. § 24-10-101, et seq.

14. Termination:

City may terminate this Master Purchase Order, in whole or in part, at any time and for any reason immediately upon written notice to Vendor. In the event of such a termination, City's sole liability shall be limited to payment of the amount due for the goods/services accepted by City. Vendor acknowledges the risks inherent in this termination for convenience and expressly accepts them. Termination by City shall not constitute a waiver of any claims City may have against Vendor.

15. Interference:

Vendor shall notify the Director of Purchasing immediately of any condition that may interfere with the performance of Vendor's obligations under this Master Purchase Order and confirm such notification in writing within twenty-four (24) hours. City's failure to respond to any such notice shall in no way act as a waiver of any rights or remedies City may possess.

16. Venue, Choice of Law and Disputes:

Venue for all legal actions shall lie in the District Court in and for City and County of Denver, State of Colorado, and shall be governed by the laws of the State of Colorado as well as the Charter and Revised Municipal Code, rules, regulations, Executive Orders, and fiscal rules of City. All disputes shall be resolved by administrative hearing, pursuant to the procedure established by D.R.M.C. § 56-106. Director of Purchasing shall render the final determination.

17. Assignment/No Third Party Beneficiary:

Vendor shall not assign or subcontract any of its rights or obligations under this Master Purchase Order without the written consent of City. In the event City permits an assignment or subcontract, Vendor shall continue to be liable under this Master Purchase Order and any permitted assignee or subcontractor shall be bound by the terms and conditions contained herein. This Master Purchase Order is intended solely for the benefit of City and Vendor with no third party beneficiaries

18. Notice:

Notices shall be made by Vendor to the Director of Purchasing and by City to Vendor at the addresses provided herein, in writing sent registered, return receipt requested.

19. Compliance With Laws:

Vendor shall observe and comply with all federal, state, county, city and other laws, codes, ordinances, rules, regulations and executive orders related to its performance under this Master Purchase Order. City may immediately terminate this Master Purchase Order, in whole or in part, if Vendor or an employee is convicted, plead nolo contendere, or admits culpability to a criminal offense of bribery, kickbacks, collusive bidding, bid-rigging, antitrust, fraud, undue influence, theft, racketeering, extortion or any offense of a similar nature.

20. Insurance:

Vendor shall secure, before delivery of any goods/services, the following insurance covering all operations, goods and services provided to City. Vendor shall keep the required insurance coverage in force at all times during the term of the Master Purchase Order, or any extension thereof, during any warranty period, and for three (3) years after termination of this Master Purchase Order. The required insurance shall be underwritten by an insurer licensed to do business in Colorado and rated by A.M. Best Company as "A-"VIII or better. Each policy shall contain a valid provision or endorsement requiring notification to the City in the event any of the required policies be canceled or non-renewed before the expiration date thereof. Such written notice shall be sent to the parties identified in the Notices section of this Agreement. Such notice shall reference the City contract number listed on the signature page of this Agreement. Said notice shall be sent thirty (30) days prior to such cancellation or non-renewal unless due to non-payment of premiums for which notice shall be sent ten (10) days prior. If such written notice is unavailable from the insurer, contractor shall provide written notice of cancellation, non-renewal and any reduction in coverage to the parties identified in the Notices section by certified mail, return receipt requested within three (3) business days of such notice by its insurer(s) and referencing the City's contract number. If any policy is in excess of a deductible or self-insured retention, City must be notified by Vendor. Vendor shall be responsible for the payment of any deductible or self-insured retention. The insurance coverages specified in this Master Purchase Order are the minimum requirements, and these requirements do not lessen or limit the liability of Vendor. Risk Management reserves the right to require additional policies and/or limits based on agreement scope of work. Vendor shall provide a copy of this Master Purchase Order to its insurance agent or broker. Vendor may not commence services or work relating to the Master Purchase Order prior to placement of coverage. Contractor certifies that the attached certificate of insurance attached to the Master Purchase Order documents, preferably an ACORD certificate, complies with all insurance requirements of this Master Purchase Order. The City's acceptance of a certificate of insurance or other proof of insurance that does not comply with all insurance requirements set forth in this Master Purchase Order shall not act as a waiver of Vendor's breach of this Master Purchase Order or any of the City's rights or remedies under this Agreement. The City's Risk Management Office may require additional proof of insurance, including but not limited to policies and endorsements. Vendor's insurer shall name as Additional Insured to its Commercial General Liability and Business Auto Liability policies the City and County of Denver, its elected and appointed officials, employees and volunteers. Vendor's insurer shall waive subrogation rights against the City. All sub-contractors and sub-consultants (including independent contractors, suppliers or other entities providing goods/services required by this Master Purchase Order) shall be subject to all of the requirements herein and shall procure and maintain the same coverages required of Vendor. Vendor shall include all such entities as insureds under its policies or shall ensure that they all maintain the required coverages. Vendor shall provide proof of insurance for all such entities upon request by City. For Worker's Compensation Insurance, Vendor shall maintain the coverage as required by statute for each work location and shall maintain Employer's Liability insurance with limits of \$100,000 for each bodily injury occurrence claim, \$100,000 for each bodily injury caused by disease claim, and \$500,000 aggregate for all bodily injuries caused by disease claims. Vendor expressly represents to City, as a material representation upon which City is relying, that none of the Vendor's officers or employees who may be eligible under any statute or law to reject Workers' Compensation Insurance shall effect such rejection during any part of the term of this Master Purchase Order, and that any such rejections previously effected, have been revoked. Vendor shall maintain Commercial General Liability coverage with limits of \$1,000,000 for each occurrence, \$1,000,000 for each personal and advertising injury claim, \$2,000,000 products and completed operations aggregate, and \$2,000,000 policy aggregate. Vendor shall maintain Business Auto Liability coverage with limits of \$1,000,000 combined single limit applicable to all owned, hired and non-hired vehicles used in performing services under this Master Purchase Order. For Commercial General Liability coverage, the policy must provide the following: (i) That this Master Purchase Order is an Insured Contract under the policy; (ii) Defense costs in excess of policy limits(iii) A severability of interests, separation of insureds or cross liability provision; and (iv) A provision that coverage is non-contributory with other coverage or self-insurance provided by City. For claims-made coverage, the retroactive date must be on or before the first date when any goods or services were provided to City. Vendor must advise the City in the event any general aggregate or other aggregate limits are reduced below the required per occurrence limits. At their own expense, and where such general aggregate or other aggregate limits have been reduced below the required per occurrence limit, the Contractor will procure such per occurrence limits and furnish a new certificate of insurance showing such coverage is in force.

21. Severability:

If any provision of this Master Purchase Order, except for the provisions requiring appropriation and encumbering of funds and limiting the total amount payable by City, is held to be invalid, illegal or unenforceable by a court of competent jurisdiction, the validity of the remaining portions or provisions shall not be affected if the intent of City and Vendor can be fulfilled.

22. Survival:

All terms and conditions of this Master Purchase Order which by their nature must survive termination/expiration shall so survive. Without limiting the foregoing, Vendor's insurance, warranty and indemnity obligations shall survive for the relevant warranty or statutes of limitation period plus the time necessary to fully resolve any claims, matters or actions begun within that period. Bonds shall survive as long as any warranty period.

23. No Construction Against Drafting Party:

No provision of this Master Purchase Order shall be construed against the drafter.

24. Status of Vendor/Ownership of Work Product:

Vendor is an independent contractor retained on a contractual basis to perform services for a limited period of time as described in Section 9.1.1E(x) of the Charter of City. Vendor and its employees are not employees or officers of City under Chapter 18 of the D.R.M.C. for any purpose whatsoever. All goods, deliverables, hardware, software, plans, drawings, reports, submittals and all other documents or things furnished to City by Vendor shall become and are the property of City, without restriction.

25. Records and Audits:

Vendor shall maintain for three (3) years after final payment hereunder, all pertinent books, documents, papers and records of Vendor involving transactions related to this Master Purchase Order, and City shall have the right to inspect and copy the same.

26. Remedies/Waiver:

No remedy specified herein shall limit any other rights and remedies of City at law or in equity. No waiver of any breach shall be construed as a waiver of any other breach.

27. No Discrimination in Employment:

Vendor shall not refuse to hire, discharge, promote or demote, or to discriminate in matters of compensation against any person otherwise qualified, solely because of race, color, religion, national origin, gender, age, military status, sexual orientation, marital status, or physical or mental disability; and Vendor shall insert the foregoing provision in any subcontracts hereunder.

28. Use, Possession or Sale of Alcohol or Drugs:

Vendor shall cooperate and comply with the provisions of Executive Order 94. Violation may result in City terminating this Master Purchase Order or barring Vendor from City facilities or from participating in City operations.

29. Conflict of Interest:

No employee of City shall have any personal or beneficial interest in the goods/services described in this Master Purchase Order; and Vendor shall not hire or contract for services any employee or officer of City which would be in violation of City's Code of Ethics, D.R.M.C. §2-51, et seq. or the Charter §§ 1.2.8, 1.2.9, and 1.2.12.

30. Advertising and Public Disclosure:

The Vendor shall not include any reference to the Master Purchase Order or to services performed or goods purchased pursuant to the Master Purchase Order in any of the Vendor's advertising or public relations materials without first obtaining the written approval of the Director of Purchasing.

31. No Employment of Illegal Aliens to Perform Work Under The Agreement:

a. This Agreement is subject to Division 5 of Article IV of Chapter 20 of the Denver Revised Municipal Code, and any amendments (the "Certification Ordinance").

b. The Contractor certifies that:

- (1) At the time of its execution of this Agreement, it does not knowingly employ or contract with an illegal alien who will perform work under this Agreement.
- (2) It will participate in the E-Verify Program, as defined in § 8-17.5-101(3.7), C.R.S., to confirm the employment eligibility of all employees who are newly hired for employment to perform work under this Agreement.

c. The Contractor also agrees and represents that:

- (1) It shall not knowingly employ or contract with an illegal alien to perform work under the Agreement.
- (2) It shall not enter into a contract with a subconsultant or subcontractor that fails to certify to the Contractor that it shall not knowingly employ or contract with an illegal alien to perform work under the Agreement.
- (3) It has confirmed the employment eligibility of all employees who are newly hired for employment to perform work under this Agreement, through participation in the E-Verify Program.
- (4) It is prohibited from using the E-Verify Program procedures to undertake pre-employment screening of job applicants while performing its obligations under the Agreement, and that otherwise requires the Contractor to comply with any and all federal requirements related to use of the E-Verify Program including, by way of example, all program requirements related to employee notification and preservation of employee rights.
- (5) If it obtains actual knowledge that a subconsultant or subcontractor performing work under the Agreement knowingly employs or contracts with an illegal alien, it will notify such subconsultant or subcontractor

and the City within three (3) days. The Contractor will also then terminate such subconsultant or subcontractor if within three (3) days after such notice the subconsultant or subcontractor does not stop employing or contracting with the illegal alien, unless during such three-day period the subconsultant or subcontractor provides information to establish that the subconsultant or subcontractor has not knowingly employed or contracted with an illegal alien.

(6) It will comply with any reasonable request made in the course of an investigation by the Colorado Department of Labor and Employment under authority of § 8-17.5-102(5), C.R.S, or the City Auditor, under authority of D.R.M.C. 20-90.3.

d. The Contractor is liable for any violations as provided in the Certification Ordinance. If Contractor violates any provision of this section or the Certification Ordinance, the City may terminate this Agreement for a breach of the Agreement. If the Agreement is so terminated, the Contractor shall be liable for actual and consequential damages to the City. Any such termination of a contract due to a violation of this section or the Certification Ordinance may also, at the discretion of the City, constitute grounds for disqualifying Contractor from submitting bids or proposals for future contracts with the City.

This Master Purchase Order is acknowledged and agreed to by:

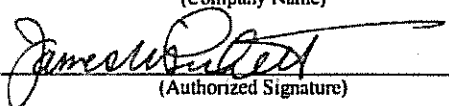
Vendor Name: Toter, LLC
(Company Name)
By: 
(Authorized Signature)
Print Name: James W. Pickett
Title: Vice President, Sales
Date: August 28, 2015

City & County of Denver, Purchasing Division

By: 
Print Name: Melissa Bordwine
Title: Senior Buyer
Date: 9-1-15

EXHIBIT "A"

Vendor: Toter, LLC.
Title: Recycling, Trash and Compost Carts
Master Purchase Order No.: 0578A0115

It is recommended that you use your Master Purchase Order No. – 0578A0115, in all future correspondence, billing, invoicing or other communications.

A.1 SPECIFICATIONS AND REQUIREMENTS:

It is the intent of the City and County of Denver to purchase recycling, trash and/or compost carts that conform to the best practices known to the trade in design, quality of material, and workmanship. Carts shall be standard and interchangeable throughout the entire quantity of carts provided to the City pursuant to award of a particular bid item. Carts shall be new and unused.

A.1.a CART DESIGN:

Cart shall be compatible with a fully automated and semi-automated collection system and shall comply with ANSI standards B/G type cart of ANSI Z245.60 2008 and must meet safety standards of ANSI Z245.30 2008.

Carts shall be stable and self-balancing in an upright position, whether loaded or empty and shall maintain stability when returned to the ground after dumping.

Empty carts shall be able to maintain an upright position in sustained or gusting winds up to 25 miles per hour from any direction.

Carts shall be designed to be easily maneuvered when filled to the maximum designed weight on a level or sloped surface.

A.1.b CART MATERIAL:

Carts shall be manufactured of first quality virgin polyethylene resin and post-consumer recycled polyethylene resin of equal quality.

Post-consumer recycled resin should make up a minimum of 10% by weight. Toter has included a letter(s) certifying the actual percentage of post-consumer and pre-consumer resin used in the containers by weight of the container (that is, % in lid, % in body, % in wheels, etc.) and the sources of that resin.

All virgin resin must be provided by a nationally recognized brand supplier (petrochemical supplier) such as Phillips, Dow, Dupont, BP, Exxon, etc., and must satisfy the manufacturer's original specification for first quality material.

The carts shall be molded of polyethylene resin meeting the requirements of ASTM D4976 "Specifications for Polyethylene Plastics Molding and Extrusion Materials," table PE as follows:

Group	2 Linear	
Class	3 Density 0.940-0.960	ASTM 4883
Grade	3, Flow Rate 1-10 decigrams/minute	ASTM D1238

	Tensile Yield Strength 2600 psi minimum and Elongation at break of 200%	ASTMD638, type IV specimen, 2 inch/minute crosshead rate.
	Secant modulus, 65,000 psi minimum	ASTM D790B, at 2% strain, specimen 0.125"x0.50" with 2" span.

If the cart is rotationally molded, the impact strength of molded specimens at -40C shall exceed 50 ft lbs as tested by ARM (Association of Rotational Molding) impact test using 1/8" thick specimen.

*A rotationally molded resin may have density as low as 0.935.

If the container is injection molded, the tensile impact strength of molded specimens at -40C shall exceed 120 ft lb/sq in as tested by ASTM D1822.

The cart resin shall contain sufficient ultraviolet absorber additive (ultraviolet stabilizer additive) to provide protection from ultraviolet degradation in the direct sunlight of Denver, Colorado for a period of 10 years without brittle fracture in normal use. Resin shall contain a minimum of 0.43% ultraviolet stabilizer additive.

Resin weight for the 35 gallon cart should be no less than 16 lbs for the base and the lid. 65 gallon cart should be no less than 26 lbs for the base and lid. Resin weight for the 95 gallon carts shall be no less than 34 lbs for the base and the lid. Both weights shall be unassembled carts and shall not include the wheels or other materials required for assembly.

Carts must be made from a material that can be recycled at its end of life. The ability to recycle the cart into another beneficial use product is essential.

A.1.c CART COLOR:

The carts shall be supplied in three main colors. Trash carts are black and must have a reflective coating in the hot stamp on each side. The recycle carts shall be purple in color, and shall be a reasonable match to PMS 2755. The compost carts shall be Kelly green. The City may chose to order any size in purple, green and black. The colors must be matched to current carts in use. Color must be hot melted into the resin with 1/2 to 1% color pigment. Dry mixing and or blending of pigment and resin are unacceptable. Color must be uniform within the cart and shall not be streaked in the finished product. Toter shall provide Denver Recycles/Solid Waste Management with color samples prior to production.

The city reserves the right to changes these colors. Should the City need to change the cart color, that change will be requested prior to an order being placed.

A.1.d CART DIMENSIONS AND CAPACITY:

The carts supplied must be of three sizes:

- a. No less than 90 gallon and no greater than 100 gallon
- b. No less than 60 gallon and no greater than 68 gallon
- c. No less than 35 gallon and no greater than 45 gallon

All volumetric capacities are expressed as liquid measures and shall be measured at the full level of the cart body, excluding any additional volume enclosed by the domed lid in the closed position.

The maximum width of the lid and cart shall be:

- a. Twenty-two (22) inches for 35 gallon cart
- b. Twenty-eight (28) inches for 65 gallon cart
- c. Thirty-two (32) inches for the 95 gallon cart

Total height including lid on all sizes shall be no greater than forty-seven (47) inches.

Horizontal section of the carts shall not be square at the place where it is picked up by the clasping arm. The minimum curvature shall be 26%.

Toter shall submit drawings, on 8 ½ x 11 paper illustrating the relevant container dimensions.

A.1.e CART LIDS:

Each cart shall be furnished with a lid molded from the same quality material as the cart body.

When open, the lid shall expose the entire circumference of the cart body to allow for clean, smooth dumping.

The lid shall be of such configuration that it shall not warp, bind, slump, or distort.

Lid shall shed water by an overlap not to exceed 1 inch over cart and shall be dome shaped.

The lid shall be designed to remain closed in winds up to 30 miles per hour from any direction. Toter has furnished wind tunnel test information based upon the relevant ANSI testing standard.

The lid shall be attached to the cart without the use of a metal hinge, metal cable, or metal pin. Lids with a living hinge are not acceptable. And the lid and hinge shall be designed to withstand and maintain functionality through the serviceable life of the cart.

The lid shall have the same approximate thickness as the cart base.

The lid shall have space for a photographic education message to be placed on it. The City will provide Toter with 4-color photographic artwork that will be no smaller than 4 x 16, or 9 x 14 inches. It is required that this education message be in-molded into the lid and produce a high quality visual image. It is required that the label be photographic quality. The lid shall also contain two (2) arrows, with language to be determined indicating the cart should face this way.

The lid shall open to a minimum of 110 degrees.

The lid and cart must be designed so that a full or empty container will not flip backwards when opening the lid.

A.1.f CART BASE:

The exterior of the cart shall be of textured non-slip finish. It shall be free from sharp corners, edges, points and other structures that could present a hazard or nuisance. Carts shall be adequately designed to prevent slipping through lifting arm when lifted and turned upside down.

The interior surface of the cart shall have a high-gloss finish.

The cart base shall have molded/hot-stamped into it in a prominent location the manufacturer's name, the month and year of manufacture and cart serial number.

Carts shall be hot stamped on up to three sides with messages selected by the City. The City prefers that hot stamped messages on the carts purchased for use in the **trash** collection program have **reflective** hot stamp messages, however non-reflective hot stamps will be considered. This applies only to the trash carts. Messages shall incorporate the following information (subject to modification after award):

Recycle cart message:

- “Please place the container at the designated pick up area by 7:00AM on your day of service. This container and its contents are the property of the City and County of Denver and distributed for the express purpose of holding residential recyclable materials.” (Approximate size 6” x 6”)
- “Scavenging is prohibited” (Approximate size 6” x 6”).
- Denver Recycles Logo, Phone Number and Web Address (Approximate size 12” x 12”)

Trash cart message:

- “Please place the container at the designated pick up area by 7:00AM on your day of service. This container and its contents are the property of the City and County of Denver and distributed for the express purpose of holding residential waste materials.” (Approximate size 6” x 6”)
- “Scavenging is prohibited” (Approximate size 6” x 6”).
- City and County of Denver (Approximate size 12” x 12”)

Compost carts:

- “Please place the container at the designated pick up area by 7:00AM on your day of service. This container and its contents are the property of the City and County of Denver and distributed for the express purpose of holding residential compostable materials.” (Approximate size 6” x 6”)
- “Scavenging is prohibited” (Approximate size 6” x 6”).
- Denver Composts logo, phone # and Web Address (Approximate size 12” x 12”)

The cart handles and lid hinges must be designed so the cart can be dumped cleanly from any angle.

The cart handle must be designed so that it is attached to the cart without penetrating the surface of the cart body. The cart handle may be part of the hinge. The only exposed portion of the hinge shall be the gripping surface. All other hinge points shall be completely enclosed in a cylinder and molded into the cart. The cart handle must be so designed that if broken it can be replaced to its original condition. Each handle shall have two grasping locations. Handles mounted with screws, bolts or fasteners are unacceptable.

Axle brackets shall be molded into the cart body and shall be positioned in such a manner that they support the outer ends of the axle. They shall be set against the hub of the wheel for maximum support. The cart shall have molded-in “wheel wells” of such size so that the wheels are fully recessed within the bottom width diameter of the container.

The carts shall be designed to regularly receive and dump the following weights:

- 35 gallon cart up to one hundred (100) pounds
- 65 gallon cart up to two hundred (200) pounds
- 95 gallon cart up to three hundred (300) pounds

Carts must be stackable in their fully assembled condition, except for the attachment of the wheels. If the wheels

are not attached they must accompany each cart and be easy to install. Attached wheels are preferred.

Wall thickness of the base shall be no less than 0.175 inches average throughout the cart and shall be a minimum of 0.185 in critical areas defined as cart bottom, handle and lift mechanisms. Test shall be performed daily during manufacturing with results forwarded to the City prior to shipment.

Carts must come equipped with either a plastic or metal lift bar on the front of the cart to allow use in semi-automated applications. Metal lift bars must be factory installed. Plastic lift bars must be part of the cart mold. Metal lift bars are preferred.

Each cart shall have a foot-hold area on the back of the container to allow for foot placement so as to assist in tilting back the container prior to rolling it.

A.1.g CART AXLE AND WHEEL:

Each cart shall be equipped with an axle and two snap on wheels.

Axle shall be constructed of zinc chromate plated steel or approved equal, and shall be a minimum 5/8 inch in diameter.

Axle shall be located in such a manner that it is not exposed to the inside of the cart and not attached to the cart by any bolts, screws, or rivets.

Wheels shall be no less than 10 inches diameter and approximately 2 inches wide and shall be constructed of first quality grade resin. Capacity of wheels and axle shall be a minimum of two hundred (200) pounds each and four hundred pounds per pair.

A.1.h EDUCATION ASSISTANCE

Toter shall support the City and County of Denver's efforts to provide effective education to its residents. Effective education will lead to increased participation in the recycling and compost programs, which could result in an increased number of carts purchased.

The ability of Toter to provide adequate education on the lid of the cart is essential. Toter shall have the ability to in-mold the graphic education message on the lid.

Toter shall also provide the City with \$1.00 per cart for the life of this contract to support education efforts. These funds will be made available to the City on July 30th of each year and calculated based on the actual number of carts purchased during the previous year from July 1st through June 30th. These funds will be used by the City to market increased participation in the recycling and composting program.

A.1.i AVAILABILITY OF PARTS:

Replacement parts shall be readily available from the manufacturer or the distributor and must be delivered within three (3) business days of order or notice of warranty defect. Up to 250 extra lids and wheels shall be provided (upon request) annually to the City at no extra charge for replacements and repairs.

A.1.j **WARRANTY:**

By submittal of a bid, Toter provides the City with a minimum full, non-prorated, ten year warranty from date of delivery against breakage or material failure (including all hardware) for each container. Container shall be replaced or repaired if failure occurs because of:

1. Cracking, chipping, peeling, or distortion.
2. Lowered ultraviolet resistance to aging in the process of normal operational use. Fading of the plastics will be used as the guide for lowered UV resistance. A color match will be established when colors are finalized at the time of purchase as well as the shade scale. A color degradation of more than 3 shades will be considered unacceptable. For example, if the cart is an exact match to PMS 2755, color degradation to PMS 2725 would be considered unacceptable.
3. Weathering degradation, improper or inadequate materials.
4. Poor material workmanship on the part of the manufacturer.
5. Failure at attachment points for lids, hinges, wheels, or other points of attachments.

Defective carts that are replaced under the warranty provision shall be replaced as complete carts, that is, with lids provided. However, if lids should fail then only the lid shall be replaced. Toter agrees to reimburse the City for any cost that may be incurred by the City incidental to the loading; shipping; and recycling of defective carts; lids; and hardware. If Toter fails to remove any defective items at time of delivery of new carts or parts, or upon request, the City may recycle/dispose of the items and charge the vendor for the cost of said recycling/disposal.

In addition to any warranty implied by law, Toter expressly warrants all items to be new, free from defects in design, materials, and workmanship and to be fit and sufficient for their intended purpose. Toter will be required to make quarterly warranty inspection visits as needed and warranty replacement must be made within 45 calendar days.

A.1.k **ORIGINAL MANUFACTURER**

Toter must specify the manufacturer of the carts, if they are not the original manufacturer. Once specified the original manufacturer cannot sub-contract the construction of the carts for the City.

A.1.l **PRODUCT QUALITY:**

All equipment shall be new, current models. All components must be of current manufacture, no discontinued or out-of-production components. One-of-a-kind or prototypes will not be allowed.

A.1.m **CART RECYCLING AT END OF LIFE**

Toter shall be required to take back carts that have reached the end of their useful life. Old carts must be diverted from the landfill (disposal) and recycled. Toter shall be responsible for all costs associated with ensuring these carts are recycled. Toter shall communicate with the City as to proposed disposition. Landfill daily cover and waste to energy are not an acceptable means of recycling.

A.2 **DEFINITIONS:**

Post-Consumer is defined as “Material or product that has served its intended use and has been discarded for disposal after passing through the hands of a final user”.

A.3 ESTIMATED QUANTITIES:

Quantities listed are the City and County of Denver's best estimate and do not obligate the Buyer to order or accept more than City and County of Denver's actual requirements during the period of this agreement, as determined by actual needs and availability of appropriated funds. It is expressly understood and agreed that the resulting contract is to supply the City with its complete actual requirement of the materials specified in this proposal for the contract period.

Orders are usually placed two times per year; however no guarantee is made as to the frequency of orders.

The City reserves the right to place orders for larger quantities up to 30,000 carts per order, should a cart expansion be approved. The City reserves the right to request a spot quote or to perform a formal bid, if such order(s) should be needed.

A.4 ORDER QUANTITIES:

EVR II Universal/Nestable carts have truckload quantities of:

- 624 of 96 Gallon Carts (Model 79296)
- 864 of 64 Gallon Carts (Model 79264)
- 945 of 35 Gallon Carts (Model 79235)

Carts of different sizes may be mixed to make up a full truckload quantity. When mixing sizes, Toter's minimum order quantity of any one of the sizes on the truck is to be a minimum of 100 carts of the same model, color, markings and features.

Maximum number of carts that may be ordered to meet the City's delivery deadline of 6 weeks:

- 96 Gallon Carts – 60,000 carts
- 64 Gallon Carts – 30,000 carts
- 35 Gallon Carts – 10,500 carts

Larger orders may require longer delivery deadlines.

A.5 F.O.B. POINT:

All prices quoted must be quoted at a firm price F.O.B. Denver, Colorado, delivered to one of four (4) possible locations within the City limits to include:

- 5440 Roslyn
- 2013 Osage
- 7301 East Jewell
- 1271 West Bayaud

A.6 DELIVERY CONSIDERATIONS:

Deliveries are to be made as soon as possible after orders are placed and are anticipated within no more than a six (6) week period from the date the vendor receives a PO.

A.7 COOPERATIVE PURCHASING:

The City and County of Denver encourages and participates in cooperative purchasing endeavors undertaken by or on behalf of other governmental jurisdictions, pursuant to Denver Revised Municipal Code Sec. 20-64.5. To

the extent other governmental jurisdictions are legally able to participate in cooperative purchasing endeavors, the City and County of Denver supports such cooperative activities. Further, it is a specific requirement of this proposal or Request for Proposal that pricing offered herein to the City and County of Denver may be offered by the vendor to any other governmental jurisdiction purchasing the same products.

The vendor(s) must deal directly with any governmental agency concerning the placement of purchase orders, freight charges for destinations outside of the Denver Metro area, contractual disputes, invoicing, and payment. The City and County of Denver shall not be liable for any costs, damages incurred by any other entity.

A.8 PALLET CHARGE:

All pallets supplied shall be non-returnable, no deposit.

A.9 LABORATORY / PROFESSIONAL TESTING:

In the event materials shipped to the City as outlined herein indicate substandard specifications in a qualitative or quantitative manner, the City reserves the right to have a laboratory, or other appropriate professional test made. If material is found to be deficient, the vendor shall be required to pay all costs of testing. If found to meet specifications, the City shall pay all costs.

A.10 VENDOR PERFORMANCE MANAGEMENT:

Awarded vendors are required to furnish a performance report to the buyer on an annual basis, no later than the anniversary date of the applicable Master Purchase Order or City Contract, providing at a minimum the following information:

FOR GOODS

- Total dollar value of purchases per City Agency
- Total number of transactions per City Agency
- Percentage of items shipped from local stock
- Percentage of items backordered
- Average delivery time for stock material
- Average delivery time for backorders

A.11 PRICING:

RESIN MARKET PRICING ADJUSTMENTS

A resin market review and price adjustment will be allowed three (3) times each year, every four (4) months from start date of contract. The most recent "PLASTIC NEWS" Resin Price List, Volume Commodity Thermoplastics Section, Column II (Annual Volumes of 2-5 million pounds), Injection GP Pricing will be used as the basis for determining the relevant increase or decrease in quoted Cart Pricing. The most recent PLASTICS NEWS Resin Price List in effect at the time of contract award will become the initial benchmark. These PLASTIC NEWS prices are shown as a range, for example the June 22, 2015 Volume Thermoplastics List shows HDPE, Injection GP, Column II as 99 - 101 cents/lb. Historically, all pricing on the Volume Commodity Thermoplastics Sheet has normally moved in unison per PLASTICS NEWS, so this item has been chosen for comparison. The tri-annual comparison will be made using the high figures in the columns. The percentage increase or decrease will be applied to the "Current Resin Cost" you have shown in Section C.3 (Proposal Pricing Item No. 7) above at the end of the first year of the contract. The difference between the resulting cents per pound figure and the quoted

figure from Section C.3 will then be multiplied by the resin weight of the carts you supply. If the comparison results in a 5% annual increase, you will only be allowed to increase the resin component of your cart pricing by 5%, you will not be allowed to increase the total cost of the carts by 5%. If the comparison results in a 5% decrease, you will be required to reduce the resin component of your cart pricing by 5%. This new, cents per pound resin calculation will become the basis for the pricing review after Year #2 and the same formula will be used in subsequent years for the life of the contract.

EXAMPLE:

Cart Offered = 90 Gallon with 34# of resin
Quoted Price = \$50.00
Current Resin Cost (Proposal Item # 7) = \$0.95/lb.
Resin Component of Total Price = \$32.30 (\$0.95/lb x 34#)

Benchmark PLASTIC NEWS Volume Commodity Thermoplastics List, HDPE Injection GP, Column II high value at time of contract award = \$1.01/LB
PLASTIC NEWS Volume Commodity Thermoplastics List, HDPE Injection GP, Column II high value from most recent price list at one year anniversary = \$1.08/LB

Increase = 6.93% $((1.08-1.01)/1.01)$

$\$0.95$ (Original Resin Cost) x 6.93 Increase (Divide by .9307) = 1.0207/LB. This figure will be rounded up or down to whole cents, so in this instance the new benchmark price would be \$1.02/LB

$\$1.02/\text{LB} \times 34\# = \34.68 Resin Component to Total Price
 $\$34.68 - \$32.30 = \$2.38$ Resin Price Increase

Originally Quoted Cart Price = $\$50.00 + \$2.38 = \$52.38$ Cart Price for 2nd 4 month period of the Contract.

A.12 SECTION D: DECLARATION OF DATA FOR CARTS OFFERED:

Refer to Exhibit A attached below for Toter's Declaration of Data.

A.13 TOTER PRODUCT SPECIFICATIONS AND EXCEPTIONS:

Refer to Exhibit B attached below for Toter's product specifications and exceptions.

Description of the goods, and services related thereto, being purchased and pricing:

Item No.	Description	Manufacturer Offered	Model # (if applicable)	Net Unit Price
1	90 to 100 gallon cart for use in a fully automated system (Est. 25,000 per year for 3 years, 10,000 per year thereafter) as per specification or approved equal	Toter, LLC EVR II Universal/Nestable 96 Gallon Cart	Model 79296	\$45.66
Guaranteed Delivery within <u>42*</u> Calendar Days after receipt of order.				
2	60 to 68 gallon cart for use in a fully automated system (Est. 5,000 per year) as per specification or approved equal	Toter, LLC EVR II Universal/Nestable 64 Gallon Cart	Model 79264	\$39.48
Guaranteed Delivery within <u>42*</u> Calendar Days after receipt of order.				
3	35-45 gallon cart for use in a fully automated system (Est. 1,000 per year) as per specification or approved equal	Toter, LLC EVR Universal/Nestable 35 Gallon Cart	Model 79235	\$37.84
Guaranteed Delivery within <u>42*</u> Calendar Days after receipt of order.				
4	Fully assembled, wheels on at time of delivery - 90 to 100 gallon cart for use in a fully automated system as per specification or approved equal	Toter, LLC. EVR II Universal/Nestable 96 Gallon Cart	Model 79296	\$46.65
Guaranteed Delivery within <u>42*</u> Calendar Days after receipt of order.				
5	Cost of Optional REFLECTIVE logo hot stamp, per cart		\$0.40 (hot stamp on 2 opposing sides: \$0.20 per side)	
6	Cost per Cart to Install RFID Tags in/on carts (NOTE: This is an optional accessory. The City may or may not take advantage of this during the term of the agreement)		\$0.70	
* Toter agrees to meet the City's deadline of 6 weeks after receipt of purchase order, and after Toter's receipt of written order confirmation and markings approval form.				

EXHIBIT A

SECTION D: DECLARATION OF DATA FOR CARTS OFFERED IN SECTION B.1

In the following Declaration of Data you are required to respond to each Specification. If specific values are requested, you must provide the required information. For other specifications, if what you are offering is exactly as specified, show "As Specified". If your carts vary at all from the listed specification, you must provide details on the variance. If the space provided is not adequate, provide a separate sheet and reference the Specification Number with your explanation.

SPECIFICATION	CARTS OFFERED																		
Manufacturing process (rotational cross-linked, rotational linear, injection, etc.)	Mfg. Process Offered: <u>Advanced Rotational Molded</u>																		
2. Body Unit: quality of virgin and recycled materials. Please attach resin supplier reference and specification.	100% Virgin Resin, with Recycled Materials like to the quality of virgin resin. Resin supplier reference and resin data sheets attached.																		
3. Body Unit: Percentage of Pre-Consumer Waste content, Percentage of Post-Consumer Waste content and Percentage of Virgin content	<table border="1" style="width: 100%; border-collapse: collapse;"> <thead> <tr> <th style="text-align: left;">Color >>></th> <th style="text-align: center;">Black</th> <th style="text-align: center;">Green</th> <th style="text-align: center;">Purple</th> <th></th> </tr> </thead> <tbody> <tr> <td>Post-Consumer</td> <td style="text-align: center;">15%</td> <td style="text-align: center;">15%</td> <td style="text-align: center;">15%</td> <td rowspan="3" style="vertical-align: middle;">Toter wheels do not contain any recycled resin.</td> </tr> <tr> <td>Pre-Consumer</td> <td style="text-align: center;">15%</td> <td style="text-align: center;">5%</td> <td style="text-align: center;">5%</td> </tr> <tr> <td>Virgin</td> <td style="text-align: center;">70%</td> <td style="text-align: center;">80%</td> <td style="text-align: center;">80%</td> </tr> </tbody> </table>	Color >>>	Black	Green	Purple		Post-Consumer	15%	15%	15%	Toter wheels do not contain any recycled resin.	Pre-Consumer	15%	5%	5%	Virgin	70%	80%	80%
Color >>>	Black	Green	Purple																
Post-Consumer	15%	15%	15%	Toter wheels do not contain any recycled resin.															
Pre-Consumer	15%	5%	5%																
Virgin	70%	80%	80%																
4. Body capable of returning to near original shape after bending by impact or heat.	As Specified																		
5. Wall thickness (minimum 0.175", with critical points 0.185")	Please see attached explanation. Wall thickness provided is: 96G - nominal 0.172", 64G - nominal 0.164", 65G - nominal 0.154"																		
6. Color 35 gallon = black, purple (PMS 2755) and green 65 gallon = black, purple (PMS 2755) and green 95 gallon = black, purple (PMS 2755) and green	Toter will provide colors that are a reasonable match (see color chips provided in our response). Toter agrees that if the City is not satisfied with the Purple color that we have proposed, we will match the PMS 2755 to suit the City.																		
7. Ultraviolet stabilizer additive % (minimum 1%)	Please see attached explanation. Ultraviolet stabilized additive <u>minimum 0.43</u> %																		
8. Color pigment % (minimum 1/2 to 1%)	Please see attached explanation Color Pigment <u>**</u> % ** Black minimum 0.45%, 925 Green min. 0.70%, 765 Purple min. 0.79%																		
9. No dry mixing or blending of pigment	As specified; only hot melt compounded																		
10. Total number of parts	8 types of parts; specifically 1 body, 1 lid, 4 torx fasteners and 2 hinges (lid attachments), 1 stop bar, 2 wheels, 2 pal nuts, 1 axle																		

SPECIFICATION	CARTS OFFERED
11. Total resin weight of each component and total assembled weight for the 35-45 gallon cart that you are offering.	Body: <u>14.50</u> LBS. (Resin Weight) Lid: <u>2.13</u> LBS. (Resin Weight) Wheels: <u>2.40 (2 wheels)</u> LBS. (Resin Weight) Fully assembled weight: <u>21.33</u> LBS.
11. Total resin weight of each component and total assembled weight for the 60-68 gallon cart that you are offering.	Body: <u>20.00</u> LBS. (Resin Weight) Lid: <u>3.30</u> LBS. (Resin Weight) Wheels: <u>2.40 (2 wheels)</u> LBS. (Resin Weight) Fully assembled weight: <u>27.90</u> LBS.
12. Total resin weight of each component and total assembled weight for the 90-100 gallon cart that you are offering.	Body: <u>26.00</u> LBS. (Resin Weight) Lid: <u>4.30</u> LBS. (Resin Weight) Wheels: <u>2.40 (2 wheels)</u> LBS. (Resin Weight) Fully assembled weight: <u>30.52</u> LBS.
13. Dimensions: Width of cart and lid, Overall Height	Width of Cart and Lid 35-45 gallon: <u>19.75 inches</u> 35 gallon cart Width of Cart and Lid 60-68 gallon: <u>24.25" inches</u> 64 gallon cart Width of Cart and Lid 90-100 gallon: <u>29.75 inches</u> 96 gallon cart
14. Horizontal section: curvature at pickup point – please specify %.	35 gallon 60% Curvature at pickup point = 64 gallon 54%% 96 gallon 48%

SPECIFICATION	CARTS OFFERED																	
15. Actual capacity of the Base (ONLY) in U.S. Gallons	<p>Capacity of the Base ONLY on your 35-45 gal. Cart = <u>96.36 gal.</u></p> <p>Capacity of the Base ONLY on your 60-68 gal. Cart = <u>64.40 gal.</u></p> <p>Capacity of the Base ONLY on your 90-100gal. Cart = <u>35.00 gal.</u></p>																	
16. Total Base & Lid capacity in US Gallons	<p>Total Capacity-Base Plus Lid on your 35-45 gal. Cart = <u>1.4 gal</u></p> <p>Total Capacity-Base Plus Lid on your 60-68 gal. Cart = <u>2.9 gal.</u></p> <p>Total Capacity-Base Plus Lid on your 90-100gal. Cart = <u>4.7 gal.</u></p>																	
17. Maximum Weight Capacity 35-45 gallons (minimum 100lbs) 60-68 gallons (minimum 200 lbs) 90- 100 gallons (minimum 300 lbs)	<p>Weight capacity of your proposed 35-45 gallon cart: <u>122 Lbs.</u></p> <p>Weight capacity of your proposed 60-68 gallon cart: <u>224 Lbs.</u></p> <p>Weight capacity of your proposed 90-100 gallon cart: <u>336 Lbs.</u></p>																	
18. Lid constructed of same materials and manufacturing process as the cart base	<p>Cart lid is manufactured using the Injection Molding process with high density polyethylene. Cart body is manufactured using Advanced Rotational Molding process with medium density polyethylene. Please see attached explanation.</p>																	
19. Body Unit: Percentage of Pre-Consumer Waste content, Percentage of Post-Consumer Waste content and Percentage of Virgin content	<table border="1"> <thead> <tr> <th data-bbox="629 1434 844 1464">Color >>></th> <th data-bbox="844 1434 959 1464">Black</th> <th data-bbox="959 1434 1075 1464">Green</th> <th data-bbox="1075 1434 1191 1464">Purple</th> <th data-bbox="1191 1434 1318 1523" rowspan="4">Toter wheels do not contain any recycled resin.</th> </tr> </thead> <tbody> <tr> <td data-bbox="629 1464 844 1493">Post-Consumer</td> <td data-bbox="844 1464 959 1493">15%</td> <td data-bbox="959 1464 1075 1493">15%</td> <td data-bbox="1075 1464 1191 1493">15%</td> </tr> <tr> <td data-bbox="629 1493 844 1523">Pre-Consumer</td> <td data-bbox="844 1493 959 1523">15%</td> <td data-bbox="959 1493 1075 1523">5%</td> <td data-bbox="1075 1493 1191 1523">5%</td> </tr> <tr> <td data-bbox="629 1523 844 1553">Virgin</td> <td data-bbox="844 1523 959 1553">70%</td> <td data-bbox="959 1523 1075 1553">80%</td> <td data-bbox="1075 1523 1191 1553">80%</td> </tr> </tbody> </table>	Color >>>	Black	Green	Purple	Toter wheels do not contain any recycled resin.	Post-Consumer	15%	15%	15%	Pre-Consumer	15%	5%	5%	Virgin	70%	80%	80%
Color >>>	Black	Green	Purple	Toter wheels do not contain any recycled resin.														
Post-Consumer	15%	15%	15%															
Pre-Consumer	15%	5%	5%															
Virgin	70%	80%	80%															
20. Open lid exposes entire circumference of cart body allowing clean, smooth dumping	<p>As specified</p>																	
21. Lid will not warp, bind, slump, or distort	<p>As specified</p>																	

SPECIFICATION	CARTS OFFERED
22. Lid will shed water by overlap of up to 1-inch over cart and shall be dome shaped	As specified
23. Lid attached to cart without metal hinge, metal cable, or metal pin. No living hinge	As specified
24. Lid thickness same as cart base	Please see attached explanation. Lid thickness is nominal 0.125".
25. Lid shall have two arrows with language to be determined molded into it indicating direction to be placed	As specified in Addendum #01.
26. Photographic, in-molded education information to be placed on the lid. Minimum 8 1/2 x 11 inches. Four-color artwork to be provided by the city.	As specified for 96 and 64 gallon carts (meets specifications in B.1.3 with 4" x 17.25" available for 96 and 64 gallon carts). Smaller 25 gallon carts comply per Addendum #1 with available space of 3.5" x 9.75".
27. Lid to open minimum of 110°	As specified
26. Lid shall remain closed in 25-mph winds and gust from any direction. Provide wind tunnel tests if available.	As specified; wind tunnel test provided for all carts.
27. Manufacturer's name and month and year of manufacture and cart serial number molded in.	As specified
28. Cart handle and hinges designed so cart can be dumped cleanly from any angle	As specified

SPECIFICATION	CARTS OFFERED
29. Cart handle attached without penetrating surface of the body	As specified.
30. Only exposed portion of the hinge shall be the gripping surface. All other hinge points completely enclosed in cylinder and molded into the cart.	As specified per Addendum #01. Toter handle is integrally molded as a part of the cart body. Lids are completely replaceable.
31. Handle replaceable	As specified per Addendum #01. Toter handle is integrally molded as a part of the cart body.
32. Interior surface shall have high gloss finish.	As specified.
33. Exterior surface shall be non-slip	As specified.
34. Axle brackets molded into body and positioned to support outer ends of axle and against hub	As specified.
35. Wheel wells molded in for wheels to be fully recessed within the bottom width diameter of container.	As specified. This construction allows all carts bid herein to be nestable when fully assembled.
36. Wheel type – snap on, fully assembled	As specified; wheels to be fully assembled on carts requiring full assembly (page 22, item #4). All other carts bid as specified elsewhere in the City RFP, with lid, stop bar and axle factory installed
37. Axle - zinc chromate plated steel or approved equal	Axle Provided: <u>Zinc plated steel; as specified</u>
38. Axle minimum 5/8" diameter	Axle Diameter: <u>5/8" diameter; as specified</u>
39. Axle not exposed to inside of cart	As specified.
40. Axle not attached by bolts, screws or rivets	As specified.

SPECIFICATION	CARTS OFFERED
41. Wheels minimum 10" diameter x 2" wide, made of first quality resin	Wheels are 10" diameter x 1.75" width, and carts equipped with these wheels meet or exceed all ANSI Standards, serve an active 15-20+ service life, and are fully backed by our warranty.
42. Lift bar – composition and installation used.	Zinc plated steel tubing.



Toter Variances/Clarifications to Specifications
RFP No. 0578A – “Recycling, Trash and Compost Carts”

Toter’s containers meet or exceed all of ANSI Z245.30-2008 and ANSI Z245.60-2008 Standards(1), including the maximum allowable load rating.

Our carts have a 15+ year proven life and 10-year non-prorated warranty.

Toter cart failures occur at a rate of less than 2 tenths of 1% per year.

1. **A.1 – requires high density polyethylene resin for carts.** All our cart bodies are rotationally molded (a City accepted process) using linear medium density polyethylene for durability. This is the byproduct of a stress-free molding process and the most elastic and impact resistant polyethylene materials in the industry. Our carts are proven to have fewer failures in semi and fully automated collection than competitors injection molded carts. This means fewer cart failures, fewer customer complaints, and dramatically lower life cycle costs. Competitive injection molded carts have demonstrated a failure rate exceeding 2-3% annually. Our carts have an active service life of 15-20+ years. The largest injection molder of carts states on its website that the service life of its cart is 10 years and that the buyer should plan to replace carts at that age because of escalating failures.
2. **B.1.b – requires a minimum of 1% ultraviolet stabilizer additive, with Section D, #7** – The City’s specification is Our ultraviolet inhibitors are added to cart polyethylene resin at a ratio that has been determined by our engineers. These ingredients are added as a liquid blend considering the weight of the cart. Maximum dispersion of all additives into the resin is assured by the use of a hot-melt compounding process to produce consistency and durability of color for the life of the cart. The level of additives is extremely important to maintain. Too little ultraviolet inhibitors will not adequately protect the polyethylene from the effects of the sun, extreme temperatures, and other environmental factors. Too much reduces the quality and properties of the polyethylene producing a container that may not withstand the rigors of automated collection. Our carts are known as the “World’s Toughest Carts™”. Toter has stated our amount of UV additive in the City’s specification pages.
3. **B.1.b – requires resin weights for carts** – In order to compensate for an inferior, weaker high-density polyethylene resin, many injection-molding manufacturers have exerted the hypothesis that a “heavier cart” is indeed a “stronger cart”. Our use of medium density polyethylene resin, with superior impact properties (Elongation at Yield and Environmental Stress Crack Resistance), produces a cart with the best of both worlds: flexible enough to endure the rigors of automated waste collection AND comfortable enough for effortless maneuverability by the consumer. The linear medium density polyethylene used in rotational molding has 30 times the impact properties of other molding processes and is more flexible, easier to maneuver –

and carries the maximum allowable load ratings allowed by ANSI standards. The lower resin weight of our containers does not hinder in any way the performance of our carts. Our warranty failure rate of 0.02% confirms that our carts are indeed the industry's toughest, most versatile carts. Furthermore, our carts have one of the higher wind stabilities in the industry, even with lower cart resin weights. Increased wind stability and superior cart durability are both created by our advanced engineering in cart designs and our use of resilient, top-quality manufacturing materials, NOT by manufacturing a "heavier" cart. Resin weights are listed for our carts proposed herein, within the City's specification pages.

4. **B.1.c – requires ½% to 1% color in carts, with Section D, #8** – The explanation for our variance to this specification is the same as in #3 above. Our engineers have consulted with colorant suppliers for a durable and color-fast cart. Each color has a special blend of additives within. We have stated our "recipe" for these additives within the City's specification pages.
5. **B.1.c – requires a reflective coating on the hot stamp of trash carts. This marking requirement is found in other references in the City's proposal document, including C.3 – Proposal Items, Item No. 5** – At the City's request, we have offered a special foil reflective marking for trash carts, but without Warranty per the manufacturer's non-warranty to Toter.
6. **B.1.e – requires the lid to be the same approximate thickness as the cart base, with Section D, #24** - Our lids are designed for high strength with a slightly thicker wall thickness, which is a nominal 0.125". Our lids have superior durability in addition to keeping animals, insects, and rain out, while keeping odors inside the cart.
7. **B.1.f – requires cart markings** – As in #9 above, we find that location and size of markings varies from one cart manufacturer to another. With that in mind, we have provided a listing of available spaces for each size of cart within our proposal.
8. **B.1.f – requires minimum wall thicknesses, with Section D, #5** – This specification describes the wall thickness of injection molded carts. Please see our Item #3 above for the explanation that also applies to the minimum wall thickness requirements for our Advanced Rotationally Molded carts. Our carts are confidently covered by our 10 year warranty, and have an active service life of 15+ years. We have stated our wall thicknesses within the City's specification pages.
9. **B.1.g – requires wheels to be approximately 2" wide, and Section D, #41 requires minimum 2" width** – Toter's 1.75" diameter wheels are in use on MILLIONS of carts with excellent results. These wheels are blow molded with knobby treads, using high density polyethylene. The minimum RMA load rating of 200 pounds per wheel. Wheels are retained by means of a center aligned axle journal claw which snaps into a groove that is a full weight bearing surface. Wheels have a built in spacer. These

wheels have been thoroughly tested to exceed all ANSI safety standards.

10. **Section D, #18 – requires lid to be made of the same manufacturing process as the cart base.** Our lids are manufactured using the City approved injection molding process; while our bodies are manufactured using the City approved rotational molding process. Please also refer to Item #6 above.

35-GALLON CARTS

**NEW
PRODUCT!**

Toter's **NEW** 35-gallon carts are the most stable small carts available. With a large footprint, 10" wheels, and leak-proof design, they're perfect for solid waste, recyclables, and organics. Plus, they ship with lids and stop-bars already assembled — just slide axle in, attach wheels, and they're ready to go.

FEATURES:

- Manufactured with a patented stress-free **Advanced Rotational Molding™** process for superior product durability for years and years of service life.
- **Patented Rugged Rim®** technology adds rigidity and reinforced material in critical wear areas; extends life of cart.
- **Fully sealed, leak-proof design** with factory-installed 360° rotating steel stop bar.
- Bottom wear strip provides **outstanding abrasion protection**.
- Textured surface resists scratches and hides unsightly dirt.
- Large footprint and aerodynamic design create **industry-leading wind and "set-down" stability** – cart won't fall over when lid is flipped back.
- Multiple options available for **custom hot stamps, raised imprints, in-mold labeling**, etc.
- Carts **ship 2/3 assembled** (optional) – with factory-installed lids and stop bars – greatly reduces labor costs associated with cart assembly.



**Most Stable
Small Cart
Available!**
(22% more stable vs.
previous models)

Complies with
local franchise
rate structures
that specify
35-gallon carts.

35-Gallon EVRII Cart Specifications

Part Number	Capacity (Gallons)	Dimensions (L x W x H)	Load Rating	Wheel Diameter	Truck Load Qty. (2/3 Assembled)	Truck Load Qty. (Unassembled)
79235	35 gallons	24.00" x 19.75" x 38.50"	122 lbs/55 kg	10"	950	1,080

Toter®

Large areas for optional custom lid graphics including one-color hot stamps, raised imprints, or four-color in-mold labels.

User safety tips and instructions for proper use molded on top and underside of lid.

Large areas for optional custom graphics.

Patented Rugged Rim® technology adds rigidity, and reinforced material in critical wear areas extends life of cart.

Factory-installed 360° rotating steel stopbar is attached in molded-in, sealed journals to prevent leaks.

Rugged 10" wheels provide incredible stability; snap-on wheels optional.

5/8" axle provides over 2,000 lbs. of bending strength. Molded-in axle journal provides six times more support than drilled holes.

Bottom wear strip provides outstanding abrasion protection.

Larger cart capacity obtained from significant decrease in internal molding.

LOTS OF COLORS TO CHOOSE FROM!

Toter carts are available in a wide variety of standard and upscale granite colors and textures. Beautiful granite finishes complement contemporary environments, and mask normal wear by helping hide scuffs, scratches, and unsightly dirt, keeping carts looking new for many years.

STANDARD COLORS



GRAY GREEN BROWN BLACK BLUE

CONTEMPORARY GRANITE COLORS



BLUESTONE GRAYSTONE GREENSTONE SANDSTONE BROWNSTONE GREEN GRANITE DARK GRAY NAVY GRANITE BLACKSTONE

(9118)

Colors and textures shown are as accurate as printing allows. Actual product colors and textures are subject to variation from printed sample.

PO Box 5338
841 Meacham Road
Statesville, NC 28677

704-872-8171
800-424-0422

sales@wastequip.com
www.toter.com

Toter®

Toter® is a Wastequip® brand.

TOT056-032015

Toter®

TOTER® EVR™ II UNIVERSAL/NESTABLE MODELS #79296, #79264, #79235 PRODUCT SPECIFICATIONS

MATERIAL/PROCESS:

Cart body is rotationally molded, first quality LMDPE as produced by a primary manufacturer such as Exxon LL-8400 or NOVA Chemicals TI-0338-A. Cart lid is molded with equivalent polyethylene materials. Material is certified to contain a proprietary blend of ultraviolet stabilization and color hot-melt compound. Carts may be manufactured using a minimum of 10% recycled resin, subject to availability of acceptable recycled resin materials at time of production, based on color of cart and preference of customer.

CART LID:

Lid is attached securely to the body by two molded polyethylene hinges permanently attached to the lid. Rotates 270° with no interference. Lid is domed to facilitate run-off of water. Lid fits closely on top rim of cart.

LID MARKINGS:

Lid is imprinted with "Instructions" and "Indications and Contraindications" in English, French and Spanish. Custom marking hot stamped onto lid in White. Optional custom in-mold label (IML) applied to lid at factory (4 colors).

CART BODY:

Handle is an integrally molded part of the cart body. External handle diameter is 1.25". One piece handle features comfortable and convenient gripping areas. Handle is 100% part of cart body, allowing cart to be used safely without lid if necessary. Handle includes center support molded in cart body.

Top of cart body features Toter's patented Rugged Rim® for extra rigidity and tight lid fit. Container bottom features multiple bottom chimes (wear strips) for maximum abrasion protection. Container body is completely sealed without any open areas.

Stop bar is 1.0" diameter, zinc plated steel tubing and is factory installed. Stop bar rotates 360° inside molded plastic journals in the cart body during cart pickup to prevent bar damage.

Axle is 5/8" diameter zinc plated solid high strength steel fully supported by cart body. Axle slides through two molded plastic journals in the cart bottom. No bolts or rivets are used for axle mounting.

Wheels are 10" x 1.75" (nominal) blow molded with knobby treads, high density polyethylene. Minimum RMA load rating of 200 pounds per wheel. Wheels are retained by means of a center aligned axle journal claw which snaps into a groove that is a full weight bearing surface. Wheels have a built in spacer.

BODY MARKINGS:

Sequential serial numbers permanently hot stamped in White, 1½" high on front of cart body with month and year of manufacture encoded. Manufacturers name/code molded into the side. Custom marking hot stamped onto both sides of cart body in White. Optional reflective custom hot stamp marking to be applied to Trash carts.

NESTABILITY:

Nestable design on Model 79296 and Model 79264 allows FULLY ASSEMBLED carts to be stacked one inside another for storage and delivery efficiency and cost savings. Model 79232 is designed to be nestable when FULLY ASSEMBLED, and requires an 8" wheel in order to recess the wheel for stacking.

COLOR:

Ultraviolet stabilized, non-fading standard colors – Black for Trash, Purple for Recycling, and Kelly Green for Compost. Other colors available are Gray, Blue or Brown. Special Granite colors for body (solid standard color lid) are also available for no additional charge - Greenstone, Toter Green Granite, Sandstone, Brownstone, Graystone, Dark Gray Granite, Bluestone, Navy Granite, and Blackstone.

DIMENSIONS:

Model #	79296	79264	79235	
Length:	35.50"	31.50"	24.00"	
Width:	29.75"	24.25"	19.75"	Fits through gates and doors.
Height:	43.50"	41.75"	38.50"	

Toter[®] EVR™ II Universal/Nestable Cart
Models #79296, #79264, #79235 Product Specifications
Page 3

CAPACITY:

Volume 96.36 for Model 79296, 64.40 for Model 79264 and 35.00 for Model 79235, in US Gallons, body of containers only.

FINISHED WEIGHT:

Fully Assembled – 35.2 pounds for Model 79296, 27.8 for Model 79264 and 21.33 for Model 79235.

LOAD RATING:

Conforms with ANSI Standard Z245.30 which limits maximum load rating to 3.5 pounds per gallon.
Load Ratings: Model 79296 is 335 lbs., Model 79264 is 224 lbs. and Model 79235 is 122 lbs.

WARRANTY:

Container body, lid, wheels, axle, and all other parts are covered by a ten (10) year warranty.

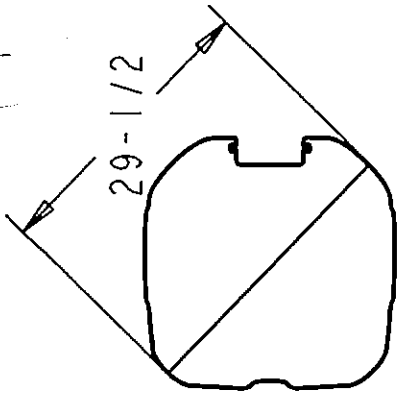
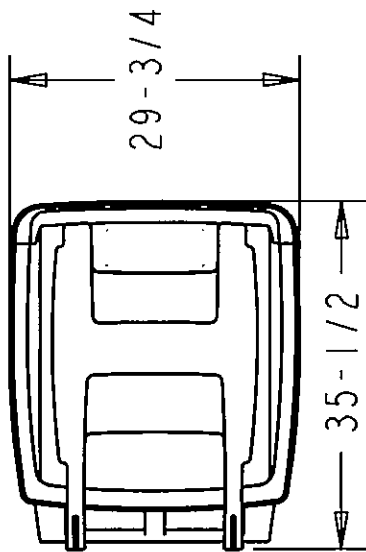
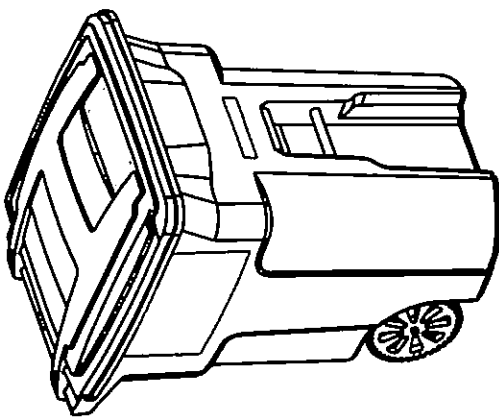

NOMINAL GRIP
DIAMETER

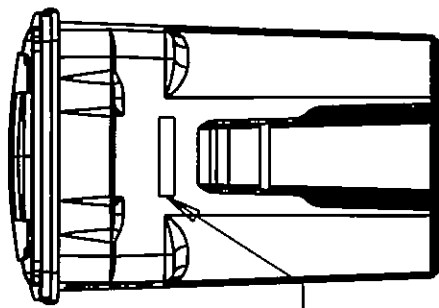
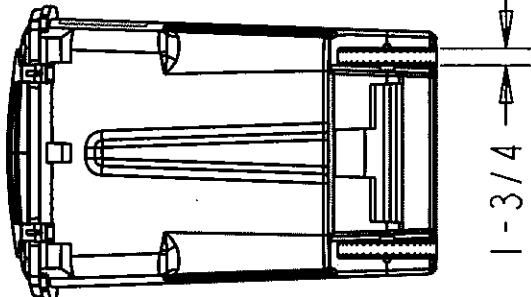
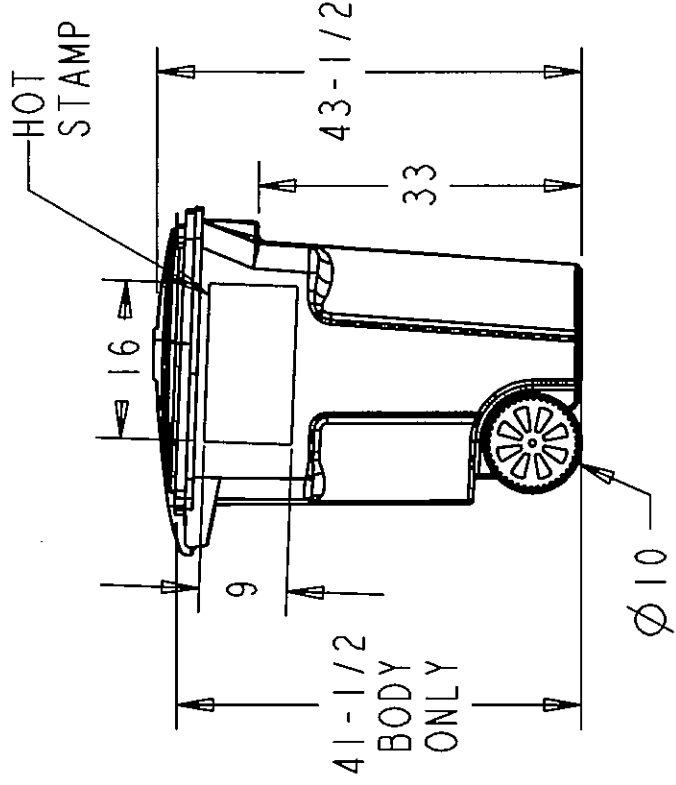

SERIAL
NUMBER

PART NO.	79296		
LOAD RATING:	335 lbs.		
PART WT./CUBE	35.2 lbs.	26.2 cu. ft.	DATE: 09-Mar-04
FEATURES:	BUGGED RIM. Nestable fully assembled. Rotating steel stopbar.		
TITLE:		96 GALLON EVR II UNIVERSAL CART	
DRAWING NO.		PS-1175	

TOTER

STATESVILLE, N.C.

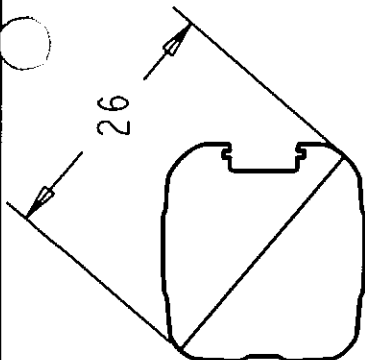
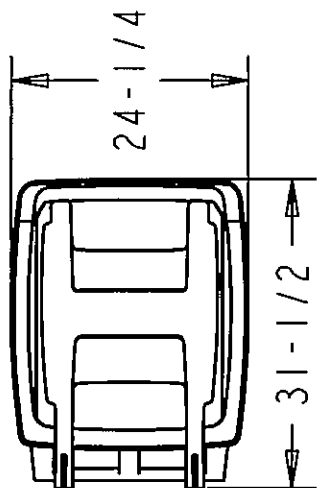
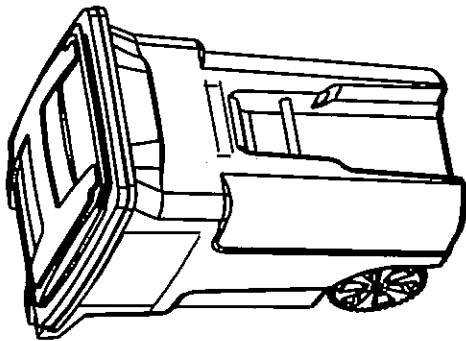

NOMINAL GRIP
DIAMETER

HOT
STAMP

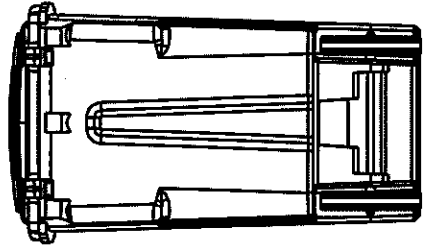
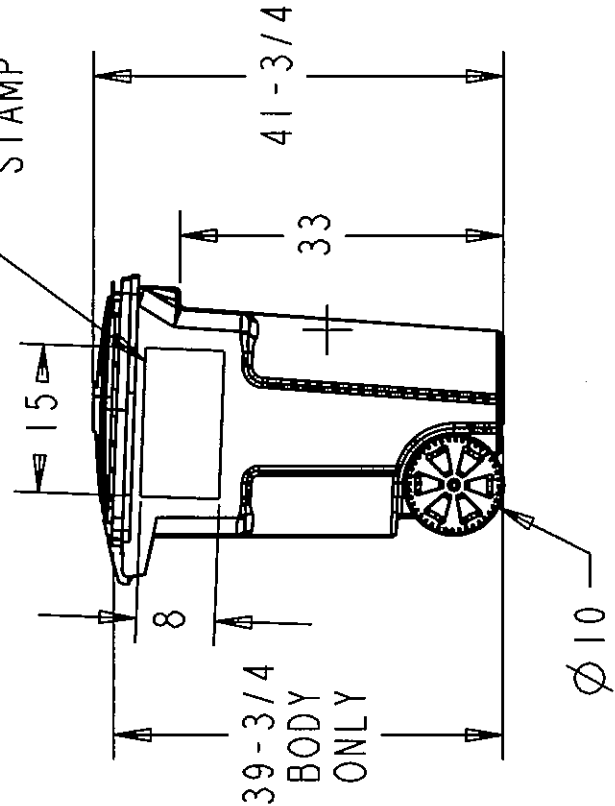

SERIAL
NUMBER

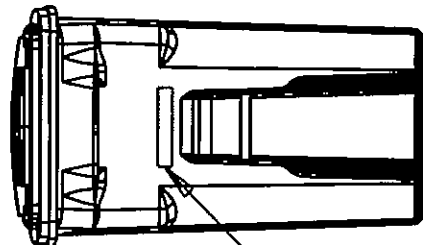

PART NO.	79264	TITLE:	64 GALLON EVR 11 UNIVERSAL CART	TOTER	STATESVILLE, N.C.
LOAD RATING:	224 lbs.	SCALE:	1:20		
WEIGHT	27.8 lbs.	DRAWING NO. PS-1174			
FEATURES:	BUGGED RIM. Nestable fully assembled. Rotating steel stopbar.				

SECTION GRIP-GRIP

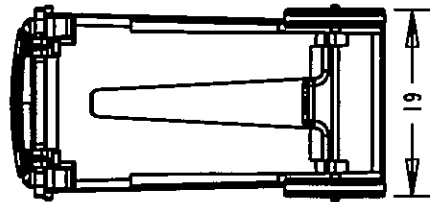
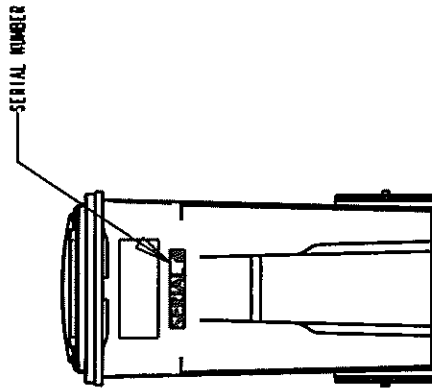
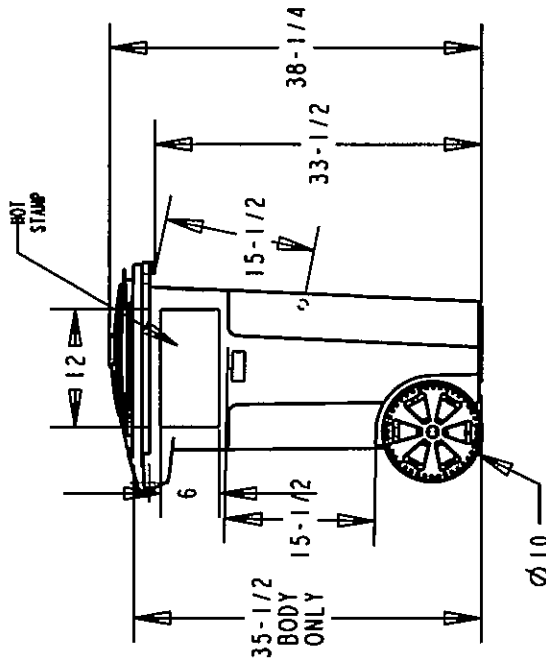
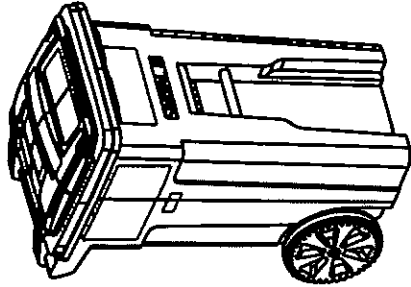
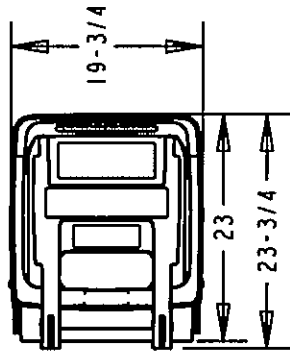
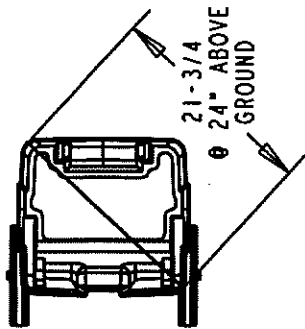

PART NO.	79235	TITLE:	35 Gallon EVR II Univ.	TOTER STATESVILLE, N.C.	DRAWING NO. PS-1212
LOAD RATING:	122 lbs.	SCALE:	0.050		
WEIGHT	21.33 lbs.	FEATURES: Rotating steel stopbar. Handle is 100% part of cart body.			



***Toter Proposed Markings
Sizes Available on Proposed Carts***

79235

Front of Cart Body (in lieu of Back hot stamp) – 3.5"H x 10"W

Opposing Sides of Cart Body – 6"H x 12"W

Lid In-Mold Label (IML) – 3.5"H x 9.75"W

79264

Front (in lieu of Back hot stamp) – 4"H x 10"W

Opposing Sides of Cart Body – 8"H x 15"W

Lid In-Mold Label (IML) – 4"H x 17.25"W, 8.125"H x 10"W

79296

Front (in lieu of Back hot stamp) – 4"H x 10"W

Opposing Sides of Cart Body – 9"H x 16"W

Lid In-Mold Label (IML) – 4"H x 17.25"W, 8.125"H x 10"W

35 GALLON

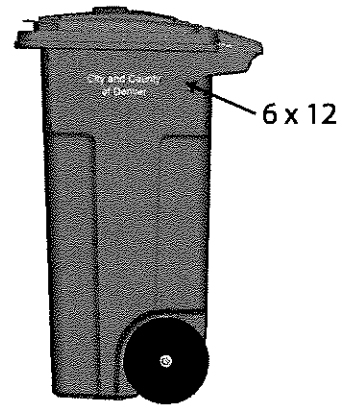
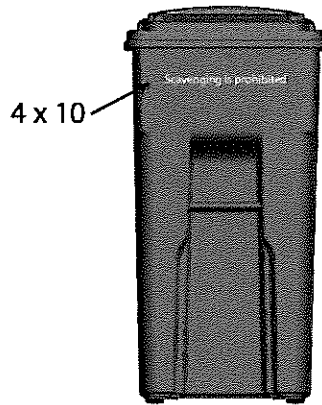
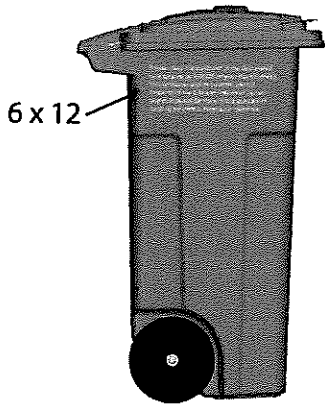

64 GALLON

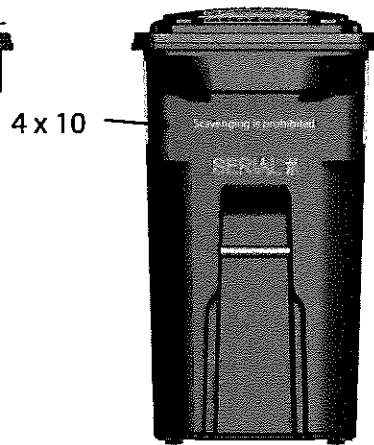
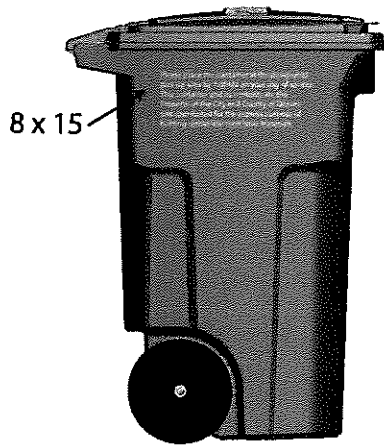

96 GALLON

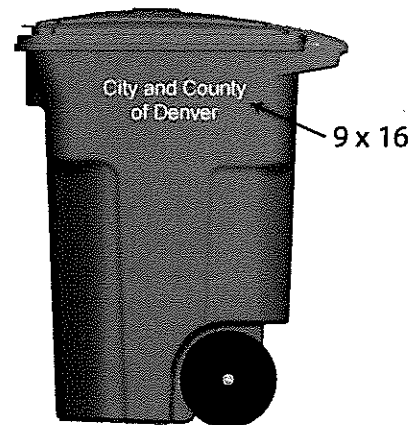
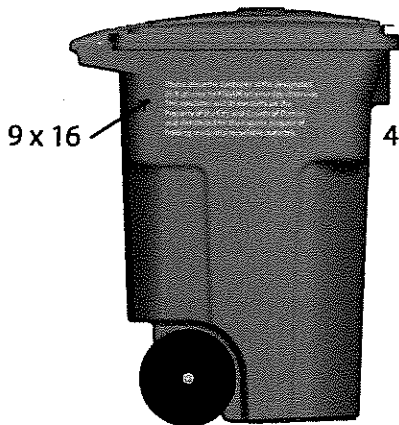

35 GALLON

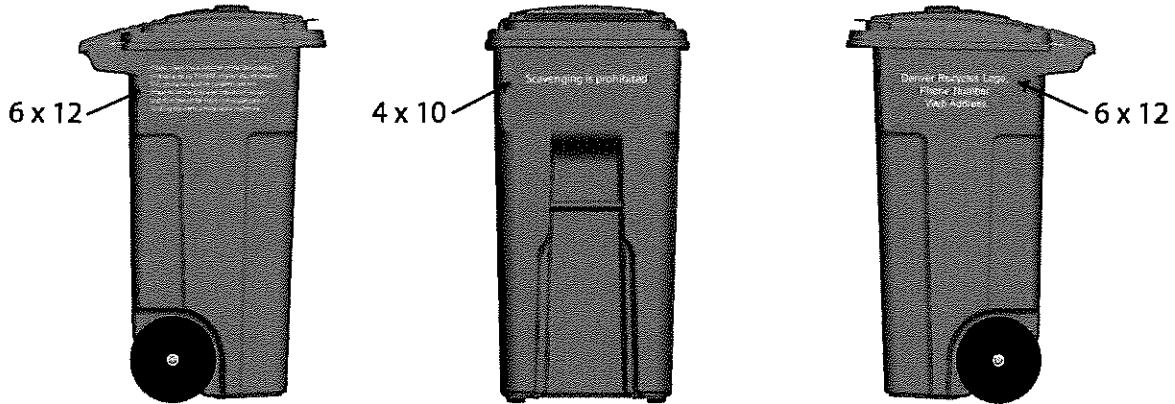

64 GALLON

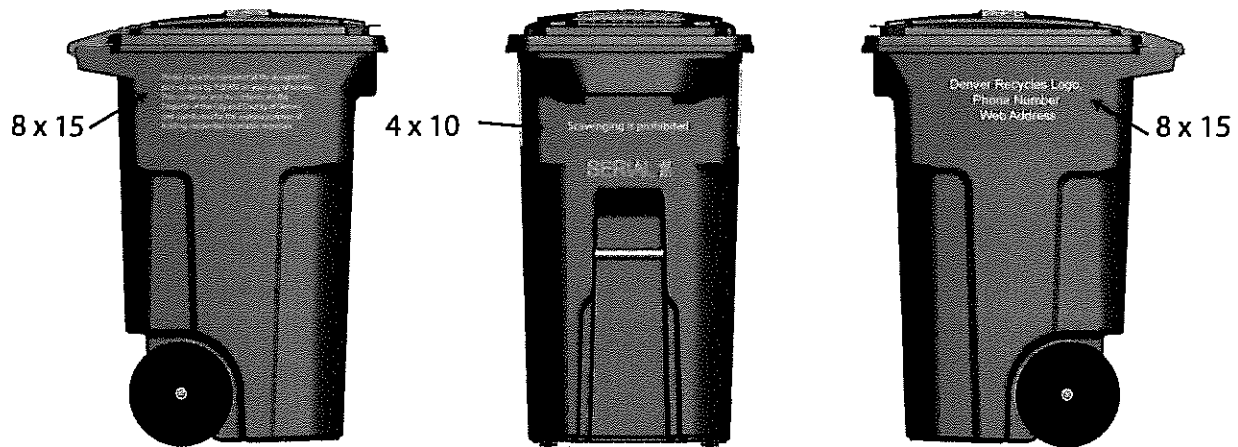

96 GALLON

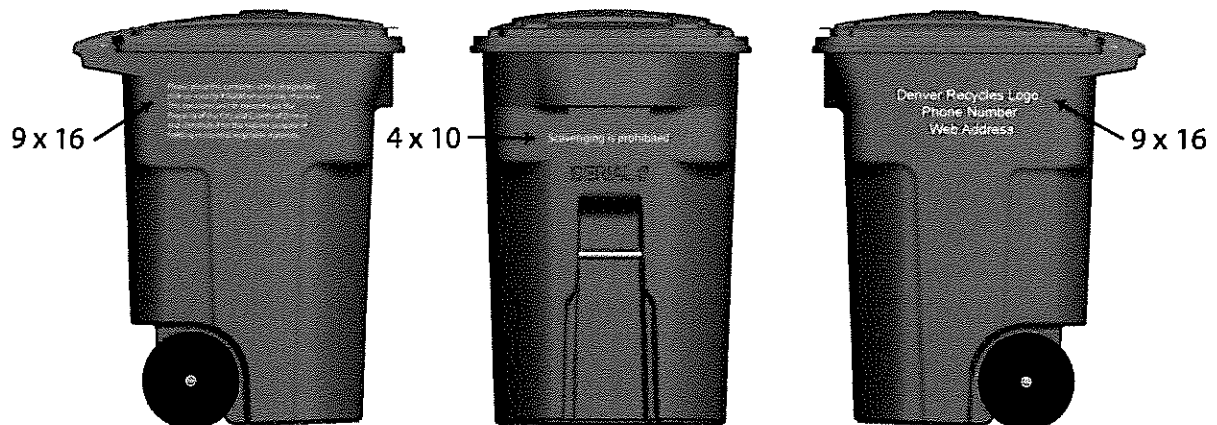

35 GALLON



64 GALLON

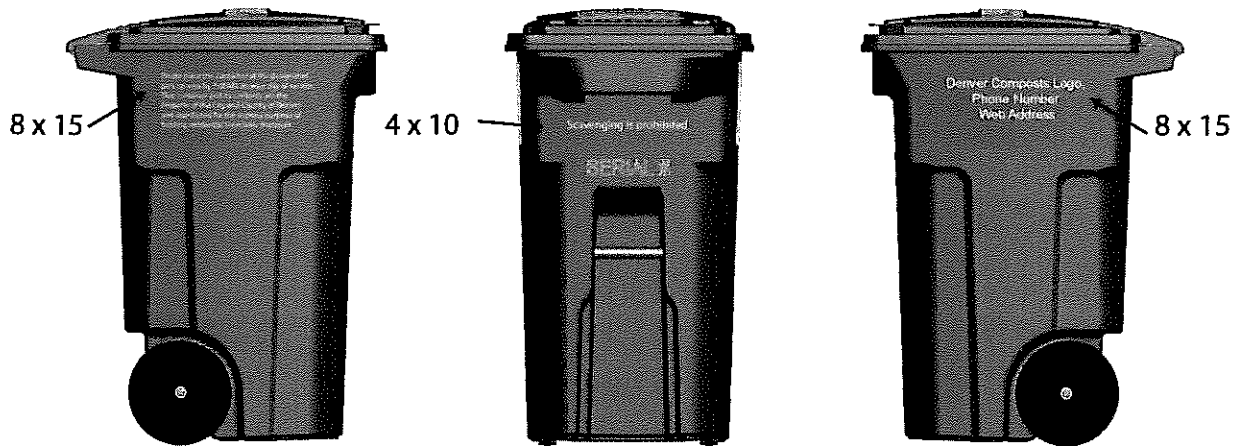

96 GALLON

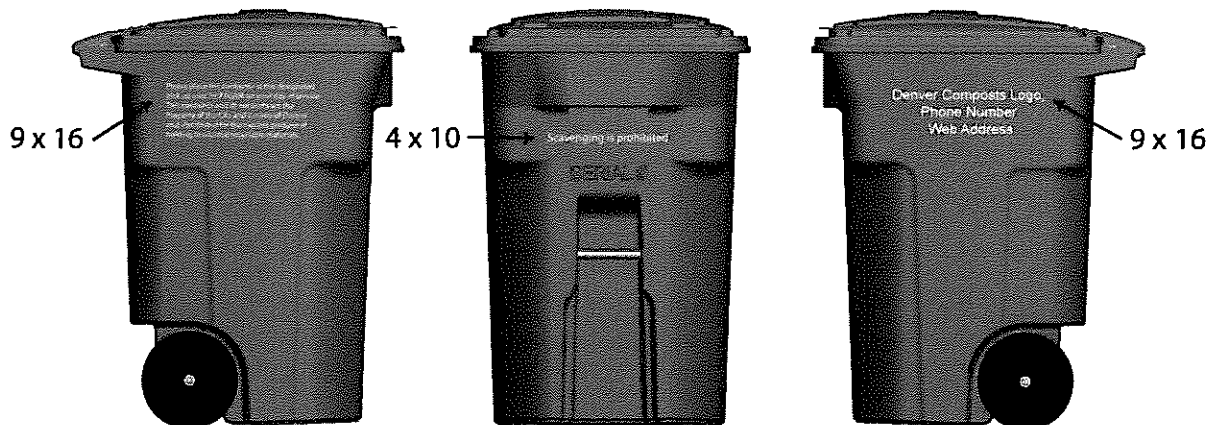



STEVE L. KNIGHT, PE
1507 MT. VERNON AVE
STATESVILLE, NC 28677
PHONE (704) 878-2996
FAX (704) 878-8887

June 6, 2008

Ms. Kellie Clarke
Toter, Inc.
841 Meacham Road
Statesville, NC 28677

RE: Cart Testing ANSI Review

Dear Ms. Clarke:

At your request, I reviewed the ANSI Z245.30 Standard for Equipment Technology and Operations for Equipment Technology and Recyclable Materials – Waste Containers – Safety Requirements revised in 2008. The previous version was issued in 1999. The purpose of the review was to determine what differences, if any, exists between the two versions. The review was limited to the sections concerning two-wheeled carts and their testing, Section 7.2.4 and the accompanying Appendixes.

The only differences found were in the way the different measuring units were presented. The 1999 version placed the metric units of measure first followed by the customary units in parenthesis. The 2008 version switched these numbers so that the metric units are last and in parenthesis.

Since there is no real change in the standard, all Toter carts tested to the previous 1999 ANSI version still conform to the new ANSI 2008 Standard Cart tests.

Thank you for allowing me to be of service to you. If I may be of further assistance, please let me know.

Sincerely,

Steve L. Knight, PE

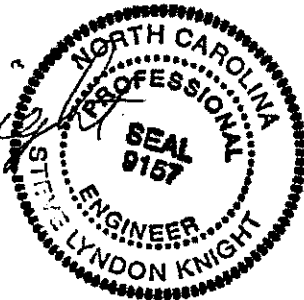



STEVE L. KNIGHT, PE

1507 MT. VERNON AVE

STATESVILLE, NC 28677

(704) 878-2996

CERTIFICATION OF VOLUMETRIC LOADING CAPACITY TEST

**TOTER® 96 GALLON EVR II UNIVERSAL NESTABLE CART BODY
PART NO. 79296**

TEST METHOD

ANSI Standard Z245.30-1999 Appendix A

RESULTS: Passed

COMMENTS

The volume contained in the body is 96.36 gallons.

CERTIFICATION

I hereby certify that the preceding test represents a test I witnessed on August 1, 2002 and was conducted according to the procedures described above.

Respectfully submitted,

Steve L Knight
Steve L. Knight, PE





STEVE L. KNIGHT, PE

1507 MT. VERNON AVE

STATESVILLE, NC 28677

(704) 878-2996

CERTIFICATION OF SLOPE STABILITY TEST

**TOTER® 96 GALLON EVR II UNIVERSAL NESTABLE CART
PART NO. 79296**

TEST METHOD

ANSI Standard Z245.30-1999 Appendix B

Test Loading: i) Empty cart, and ii) Filled cart with 335 lbs.

RESULTS: Passed

COMMENTS

The cart remained stable in all four directions.

CERTIFICATION

I hereby certify that the preceding test represents a test I witnessed on August 29, 2002 and was conducted according to the procedures described above.

Respectfully submitted,

Steve L. Knight
Steve L. Knight, PE





STEVE L. KNIGHT, PE

1507 MT. VERNON AVE

STATESVILLE, NC 28677

(704) 878-2996

CERTIFICATION OF DURABILITY DURING PULLING

**TOTER® 96 GALLON EVR II UNIVERSAL NESTABLE CART
PART NO. 79296**

TEST METHOD

ANSI Standard Z245.30-1999 Appendix C

Test Loading: i) Empty cart, and ii) Filled cart with 335 lbs.

RESULTS: Passed

COMMENTS

The handle maintained its integrity. The lid opened and closed completely. The axle remained straight and rolled true. The molded-in axle journals maintained their shape and integrity. The wheels retained their shape and rolled true. The container remained completely functional.

CERTIFICATION

I hereby certify that the preceding test represents a test I witnessed on August 13, 2002 and was conducted according to the procedures described above.

Respectfully submitted,

Steve L. Knight, PE

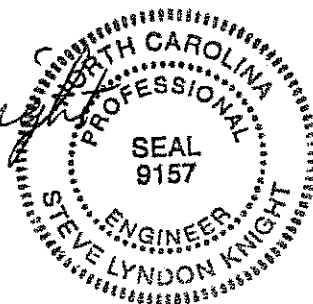



STEVE L. KNIGHT, PE

1507 MT. VERNON AVE

STATESVILLE, NC 28677

(704) 878-2996

CERTIFICATION OF LOADING AND UNLOADING TEST

**TOTER® 96 GALLON EVR II UNIVERSAL NESTABLE CART
PART NO. 79296**

TEST METHOD

ANSI Standard Z245.30-1999 Appendix D

Test Loading: Filled cart with 335 lbs.

RESULTS: Passed (semi-automated dumping)

COMMENTS

A Toter Trimlift II cart dumper was used to dump the cart with a load of 335 pounds. The cart's lifting saddle retained its shape and fit well on the dumper. The steel stop bar remained straight and free to rotate. The molded-in stop bar journals retained their shape and integrity. The cart retained its shape and remained completely functional.

CERTIFICATION

I hereby certify that the preceding test represents a test I witnessed from August 26 - 28, 2002 and was conducted according to the procedures described above.

Respectfully submitted,

Steve L. Knight, PE

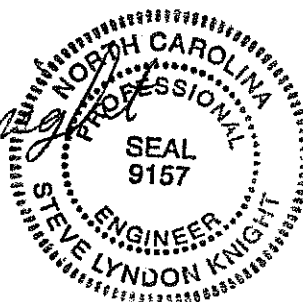



STEVE L. KNIGHT, PE

1507 MT. VERNON AVE

STATESVILLE, NC 28677

(704) 878-2996

CERTIFICATION OF LOADING AND UNLOADING TEST

**TOTER® 96 GALLON EVR II UNIVERSAL NESTABLE CART
PART NO. 79296**

TEST METHOD

ANSI Standard Z245.30-1999 Appendix D

Test Loading: Filled cart with 335 lbs.

RESULTS: Passed (automated dumping)

COMMENTS

An automated cart dumper was used to dump the cart with a load of 335 pounds. The cart's gripping area continued to fit well on the dumper after completion of test. The cart remained completely functional.

CERTIFICATION

I hereby certify that the preceding test represents a test I witnessed from August 26 - 28, 2002 and was conducted according to the procedures described above.

Respectfully submitted,

Steve L. Knight, PE

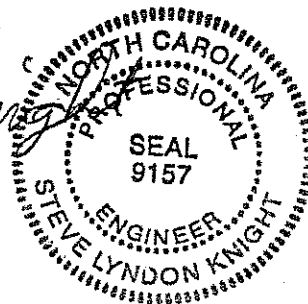



STEVE L. KNIGHT, PE

1507 MT. VERNON AVE

STATESVILLE, NC 28677

(704) 878-2996

CERTIFICATION OF CENTER-OF-BALANCE POSITION TEST

**TOTER® 96 GALLON EVR II UNIVERSAL NESTABLE CART
PART NO. 79296**

TEST METHOD

ANSI Standard Z245.30-1999 Appendix E

Test Loading: Filled cart with 335 lbs.

RESULTS: Passed

COMMENTS

The average height of the handle was 33 1/8" above the ground at its center of balance position.

CERTIFICATION

I hereby certify that the preceding test represents a test I witnessed on August 1, 2002 and was conducted according to the procedures described above.

Respectfully submitted,

Steve L. Knight

Steve L. Knight, PE

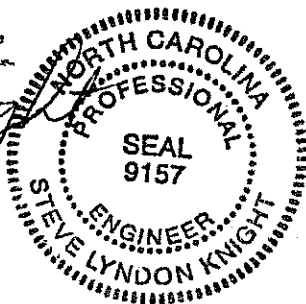



STEVE L. KNIGHT, PE

1507 MT. VERNON AVE

STATESVILLE, NC 28677

(704) 878-2996

CERTIFICATION OF FORCE TO TIP TEST

**TOTER® 96 GALLON EVR II UNIVERSAL NESTABLE CART
PART NO. 79296**

TEST METHOD

ANSI Standard Z245.30-1999 Appendix F

Test Loading: Filled cart with 335 lbs.

RESULTS: Passed

COMMENTS

The cart was tipped toward the point of balance with an average force of 67.6 pounds.

CERTIFICATION

I hereby certify that the preceding test represents a test I witnessed on August 1, 2002 and was conducted according to the procedures described above.

Respectfully submitted,

Steve L. Knight
Steve L. Knight, PE

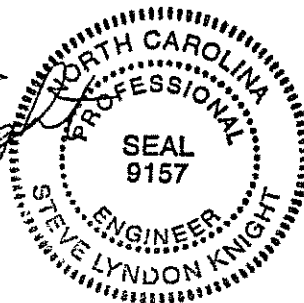



STEVE L. KNIGHT, PE

1507 MT. VERNON AVE

STATESVILLE, NC 28677

(704) 878-2996

CERTIFICATION OF LID TEST

**TOTER® 96 GALLON EVR II UNIVERSAL NESTABLE CART
PART NO. 79296**

TEST METHOD

ANSI Standard Z245.30-1999 Appendix G

RESULTS: Passed

COMMENTS

The cart lid (part number 96796) remained closed and did not collapse into the cart. The lid did deflect temporarily while loaded.

CERTIFICATION

I hereby certify that the preceding test represents a test I witnessed on August 1, 2002 and was conducted according to the procedures described above.

Respectfully submitted,

Steve L. Knight

Steve L. Knight, PE



TESTING REPORT

DATE: 15 August 2002
SUBJECT: Trash carts
PRODUCT IDENTIFICATION: Toter EVR-II, 96 gallon

TEST: WIND TUNNEL

TEST DESCRIPTION: This test is a measure of the stability of the cart in a high wind. Although not specifically tied to the basic purpose of the cart, most consumers would object to a cart that often tipped over and spilled the contents.

MINIMUM PERFORMANCE STANDARD: No standard has been set although some local standards may exist.

TEST PROCEDURE:

1. A large wind tunnel with a 54 inch diameter exit opening is used for the test. The wind was supplied by a Gates Super HC drive with capability to achieve various velocities.
2. Position the cart in the steady wind stream zone. (Approx. 48 inches from the opening.)
3. The bottom of the cart is to be level with the exit opening and is to rest on a concrete surface that has a surface texture similar to a roadway.
4. Test cart in three orientations toward the wind tunnel opening — front, side and back.
5. In each orientation, the cart should be tested against a barrier to simulate performance against a street curb. The barrier should prevent the cart from sliding.
6. Measure the air velocity at the leading surface of the cart using a certified volometer. Placement of the volometer in front of the cart and a few inches down from the top of the cart is ideal.
7. The wind velocity is raised in increments with sufficient time between changes to monitor whether the cart is stable. The highest wind velocity achieved is recorded.
8. The carts are blocked against a barrier that is placed behind the wheels. The point of non-stability (end point) is when the cart tipped over. The wind speed is taken as the average of at least 3 repetitions.
9. Modifications in cart characteristics or positioning may also be tested and noted.

TEST RESULTS:

	Orientation Towards Wind Tunnel		
	Front	Side	Back
Highest Stable Wind Speed (Blocked)	43 mph	46 mph	50 mph

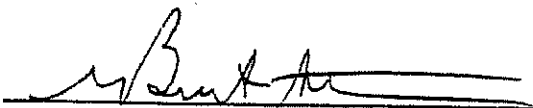
A. Brent Strong
Professor, Manufacturing Engineering Technology
Brigham Young University, Provo, UT 84602



STEVE L. KNIGHT, PE
1507 MT. VERNON AVE
STATESVILLE, NC 28677
PHONE (704) 878-2996
FAX (704) 878-8887

June 6, 2008

Ms. Kellie Clarke
Toter, Inc.
841 Meacham Road
Statesville, NC 28677

RE: Cart Testing ANSI Review

Dear Ms. Clarke:

At your request, I reviewed the ANSI Z245.30 Standard for Equipment Technology and Operations for Equipment Technology and Recyclable Materials – Waste Containers – Safety Requirements revised in 2008. The previous version was issued in 1999. The purpose of the review was to determine what differences, if any, exists between the two versions. The review was limited to the sections concerning two-wheeled carts and their testing, Section 7.2.4 and the accompanying Appendixes.

The only differences found were in the way the different measuring units were presented. The 1999 version placed the metric units of measure first followed by the customary units in parenthesis. The 2008 version switched these numbers so that the metric units are last and in parenthesis.

Since there is no real change in the standard, all Toter carts tested to the previous 1999 ANSI version still conform to the new ANSI 2008 Standard Cart tests.

Thank you for allowing me to be of service to you. If I may be of further assistance, please let me know.

Sincerely,

Steve L. Knight, PE

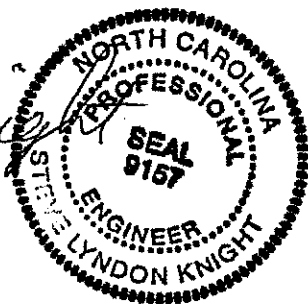



STEVE L. KNIGHT, PE

1507 MT. VERNON AVE

STATESVILLE, NC 28677

(704) 878-2996

**CERTIFICATION OF VOLUMETRIC LOADING CAPACITY
TEST**

**TOTER® 64 GALLON EVR II UNIVERSAL NESTABLE CART BODY
PART NO. 79264**

TEST METHOD

ANSI Standard Z245.30-1999 Appendix A

RESULTS: Passed

COMMENTS

The volume contained in the body is 64.4 gallons.

CERTIFICATION

I hereby certify that the preceding test represents a test I witnessed on December 18, 2002 and was conducted according to the procedures described above.

Respectfully submitted,

Steve L. Knight

Steve L. Knight, PE

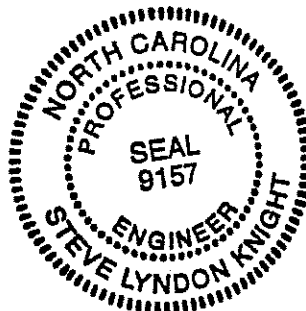



STEVE L. KNIGHT, PE

1507 MT. VERNON AVE

STATESVILLE, NC 28677

(704) 878-2996

CERTIFICATION OF SLOPE STABILITY TEST

TOTER® 64 GALLON EVR II UNIVERSAL NESTABLE CART PART NO. 79264

TEST METHOD

ANSI Standard Z245.30-1999 Appendix B

Test Loading: i) Empty cart, and ii) Filled cart with 224 lbs.

RESULTS: Passed

COMMENTS

The cart remained stable in all four directions during the loaded test.

CERTIFICATION

I hereby certify that the preceding test represents a test I witnessed on December 17, 2002 and was conducted according to the procedures described above.

Respectfully submitted,

Steve L. Knight
Steve L. Knight, PE

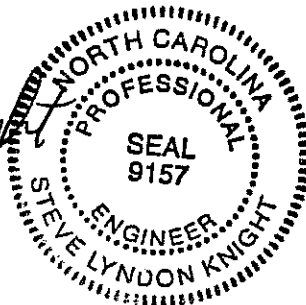



STEVE L. KNIGHT, PE

1507 MT. VERNON AVE

STATESVILLE, NC 28677

(704) 878-2996

CERTIFICATION OF DURABILITY DURING PULLING

TOTER® 64 GALLON EVR II UNIVERSAL NESTABLE CART
PART NO. 79264

TEST METHOD

ANSI Standard Z245.30-1999 Appendix C

Test Loading: i) Empty cart, and ii) Filled cart with 224 lbs.

RESULTS: Passed

COMMENTS

The handle maintained its integrity. The lid opened and closed completely. The axle remained straight and rolled true. The molded-in axle journals maintained their shape and integrity. The wheels retained their shape and rolled true. The container remained completely functional.

CERTIFICATION

I hereby certify that the preceding test represents a test I witnessed on December 19 through December 20, 2002 and was conducted according to the procedures described above.

Respectfully submitted,

Steve L. Knight
Steve L. Knight, PE

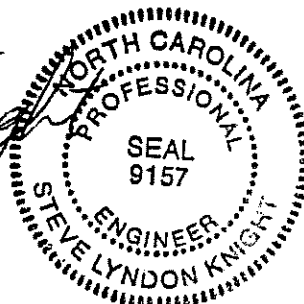



STEVE L. KNIGHT, PE

1507 MT. VERNON AVE

STATESVILLE, NC 28677

(704) 878-2996

CERTIFICATION OF LOADING AND UNLOADING TEST

TOTER® 64 GALLON EVR II UNIVERSAL NESTABLE CART
PART NO. 79264

TEST METHOD

ANSI Standard Z245.30-1999 Appendix D

Test Loading: Filled cart with 224 lbs.

RESULTS: Passed (semi-automated dumping)

COMMENTS

A Toter Trimlift II cart dumper was used to dump the cart with a load of no less than 224 pounds. The cart's lifting saddle retained its shape and fit well on the dumper. The steel stop bar remained straight and free to rotate. The molded-in stop bar journals retained their shape and integrity. The cart retained its shape and remained completely functional.

CERTIFICATION

I hereby certify that the preceding test represents a test I witnessed from December 17 through December 20, 2002 and was conducted according to the procedures described above.

Respectfully submitted,

Steve L. Knight
Steve L. Knight, PE

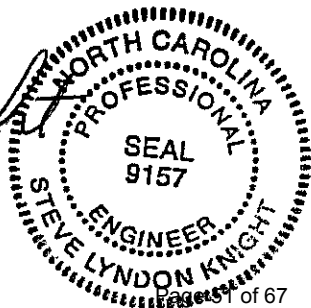



STEVE L. KNIGHT, PE

1507 MT. VERNON AVE

STATESVILLE, NC 28677

(704) 878-2996

CERTIFICATION OF LOADING AND UNLOADING TEST

TOTER® 64 GALLON EVR II UNIVERSAL NESTABLE CART
PART NO. 79264

TEST METHOD

ANSI Standard Z245.30-1999 Appendix D

Test Loading: Filled cart with 224 lbs.

RESULTS: Passed (automated dumping)

COMMENTS

An automated cart dumper was used to dump the cart with a load of no less than 224 pounds. The cart's gripping area continued to fit well on the dumper after completion of test. The cart remained completely functional.

CERTIFICATION

I hereby certify that the preceding test represents a test I witnessed from December 19 through December 30, 2002 and was conducted according to the procedures described above.

Respectfully submitted,

Steve L Knight

Steve L. Knight, PE

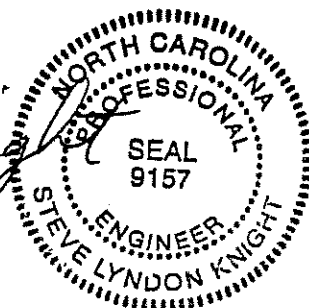



STEVE L. KNIGHT, PE

1507 MT. VERNON AVE

STATESVILLE, NC 28677

(704) 878-2996

CERTIFICATION OF CENTER-OF-BALANCE POSITION TEST

TOTER® 64 GALLON EVR II UNIVERSAL NESTABLE CART
PART NO. 79264

TEST METHOD

ANSI Standard Z245.30-1999 Appendix E

Test Loading: Filled cart with 224 lbs.

RESULTS: Passed

COMMENTS

The average height of the handle was 33 5/16" above the ground at its center of balance position.

CERTIFICATION

I hereby certify that the preceding test represents a test I witnessed on December 18, 2002 and was conducted according to the procedures described above.

Respectfully submitted,

Steve L. Knight
Steve L. Knight, PE

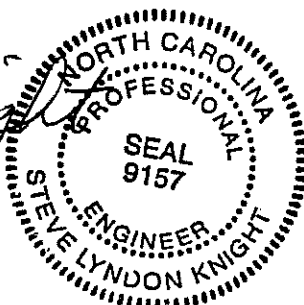



STEVE L. KNIGHT, PE

1507 MT. VERNON AVE

STATESVILLE, NC 28677

(704) 878-2996

CERTIFICATION OF FORCE TO TIP TEST

TOTER® 64 GALLON EVR II UNIVERSAL NESTABLE CART
PART NO. 79264

TEST METHOD

ANSI Standard Z245.30-1999 Appendix F

Test Loading: Filled cart with 224 lbs.

RESULTS: Passed

COMMENTS

The cart was tipped toward the point of balance with an average force of 48.8 pounds.

CERTIFICATION

I hereby certify that the preceding test represents a test I witnessed on December 18, 2002 and was conducted according to the procedures described above.

Respectfully submitted,

Steve L. Knight
Steve L. Knight, PE

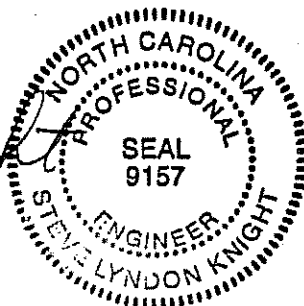



STEVE L. KNIGHT, PE

1507 MT. VERNON AVE

STATESVILLE, NC 28677

(704) 878-2996

CERTIFICATION OF LID TEST

**TOTER® 64 GALLON EVR II UNIVERSAL NESTABLE CART
PART NO. 79264**

TEST METHOD

ANSI Standard Z245.30-1999 Appendix G

RESULTS: Passed

COMMENTS

The cart lid (part number 94764) remained closed and did not collapse into the cart. The lid did deflect temporarily while loaded.

CERTIFICATION

I hereby certify that the preceding test represents a test I witnessed on December 17, 2002 and was conducted according to the procedures described above.

Respectfully submitted,

Steve L. Knight

Steve L. Knight, PE



TESTING REPORT

DATE: 27 January 2003

SUBJECT: Trash carts

PRODUCT IDENTIFICATION: Toler EVR II - 64 gallon size

TEST: WIND TUNNEL

TEST DESCRIPTION: This test is a measure of the stability of the cart in a high wind. Although not specifically tied to the basic purpose of the cart, most consumers would object to a cart that often tipped over and spilled the contents.

MINIMUM PERFORMANCE STANDARD: The specification varies from site to site depending upon prevalent wind conditions, etc.

TEST PROCEDURE:

1. A large wind tunnel with a 54 inch diameter exit opening is used for the test. The wind was supplied by a Gates Super HC drive.
2. Position the cart 48 inches from the end of the exit opening. (Beyond stagnant air zone.)
3. The bottom of the cart is to be level with the exit opening and is to rest on a concrete surface that has a surface texture similar to a roadway.
4. In one set of tests, the bottom of the cart is placed against a 6 inch brace (like a curb) to prevent the cart from rolling or sliding. In another set of tests no brace is used.
5. The wind velocity is raised until the cart starts to move. This wind speed is measured using a certified volometer.
6. Measure the air velocity to tip the cart, either free-standing or against the curb if it has rolled or slid.
7. Test cart in three orientations toward the wind tunnel opening - front, side and back.

TEST RESULTS:

Test	Orientation Towards Wind Tunnel		
	Front	Side	Back
Wind speed to tip the cart	40 mph	46 mph	46 mph

SUMMARY: The cart was stable in moderate to high winds.



A. Brent Strong
Professor, Manufacturing Engineering
Brigham Young University
265 CTB
Provo, UT 84602



STEVE L. KNIGHT, PE

1507 MT. VERNON AVE

STATESVILLE, NC 28677

(704) 878-2996

**TOTER® 35 GALLON EVR II UNIVERSAL CART
PART NO. 79235**

**CERTIFICATION OF
WASTE CONTAINERS—SAFETY REQUIREMENTS**

TEST METHOD

ANSI Standard Z245.30-2008 Appendix A-G

RESULTS: Passed, see attached table.

CERTIFICATION

I hereby certify that the attached test data represents tests I witnessed 03/23/2015 to 03/25/2015 and was conducted according to the procedures described above.

Respectfully submitted,



Steve L. Knight, PE

TOTER® 35 GALLON EVR II UNIVERSAL CART PART NO. 79235

ANSI Standard Z245.30-2008 Appendix A-E Data

TESTING REQUIREMENT	APPENDIX	LOAD RATING (LBS)	LOAD TESTED (LBS)	DATA	RESULTS
Volumetric loading capacity	A	122	n/a	The volume contained in the body is 35.00 gallons.	Passed
Slope stability	B	122	122	The cart remained stable in 4 of 4 directions for 1) Empty cart and 4 of 4 directions for 2) Cart filled.	Passed
Durability during pulling	C	122	122	The handle, axle and molded-in axle journals remained intact. The wheels retained their shape and rolled true. The container remained completely functional.	Passed
Loading and unloading, TYPE B	D	122	122	The cart's lifting saddle retained its shape and the steel stop bar remained straight and free to rotate. The molded-in stop bar journals retained their integrity. The cart remained completely functional. A stand mounted ANSI Type B lifter was used.	Passed
Loading and unloading, TYPE G	D	122	122	The cart's gripping area continued to fit well on the dumper after completion of test. The cart remained completely functional. A stand mounted ANSI Type G lifter was used.	Passed
Center of balance position	E	122	122	The average height of the handle was 29-3/4".	Passed
Force to tip	F	122	122	The average maximum force required to tip was 30.8 lbs.	Passed
Lid test	G	--	80	The cart lid remained closed and did not collapse into the cart. The lid did deflect temporarily while loaded.	Passed

TESTING REPORT

DATE: April 15, 2015
SUBJECT: Trash carts
PRODUCT IDENTIFICATION: 35 gallon EVR II cart

TEST: **WIND STABILITY**

TEST DESCRIPTION: This test is a measure of the stability of the cart in a high wind. Although not specifically tied to the basic purpose of the cart, most consumers would object to a cart that often tipped over and spilled the contents.

MINIMUM PERFORMANCE STANDARD: The specification varies from site to site depending upon prevalent wind conditions, etc. Most manufacturers expect the cart to be stable up to at least 30 mph.

TEST PROCEDURE:

1. A large wind machine with a 54 inch diameter exit opening is used for the test. The wind was supplied by a Gates Super HC drive.
2. Position the cart 48 inches from the end of the exit opening. (Beyond stagnant air zone.)
3. The bottom of the cart is to be level with the exit opening and is to rest on a concrete surface that has a surface texture similar to a roadway.
4. The bottom of the cart is placed against the top half of a 1" wood dowel. The bottom half is wedged into the test foundation which the cart wheels rest on, with the dowel's length parallel to the ground surface, so that the slight 1/2" protrusion of the dowel holds back the cart edges and/or wheels to prevent the cart from rolling or sliding.
5. The wind velocity is raised until the cart starts to move. This wind speed is measured using a certified anemometer. The anemometer is moved along the windward edges of the cart to find the position with the highest wind velocity.
6. Measure the air velocity to tip the cart, at the position with the highest velocity.
7. Test cart three times each in each of the three orientations toward the wind tunnel opening – front, side and back.

TEST RESULTS:

Test	Orientation Towards Wind Tunnel		
	Front (All roll-off)	Side (All lid-flip)	Back (Cart-tip, no lid-flip)
Wind speed to tip the cart	Avg = 39.3 mph <i>Test 1 = 39.2</i> <i>Test 2 = 39.5</i> <i>Test 3 = 39.1</i>	Avg = 45.1 mph <i>Test 1 = 45.8</i> <i>Test 2 = 44.4</i> <i>Test 3 = 45.0</i>	Avg = 39.5 mph <i>Test 1 = 40.0</i> <i>Test 2 = 39.2</i> <i>Test 3 = 39.3</i>

SUMMARY: All front-facing tests rolled over the dowel and then tipped over without concurrent lid-flip. The side facing tests all fell over concurrent with lid flip. The back-facing tests all fell over without any concurrent lid-flip.

The maximum velocity was recorded at about the height of the grip-bar on the front face of the cart.

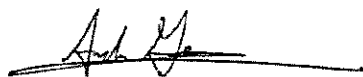

Andrew George
Assistant Professor, Manufacturing Engineering Technology
Brigham Young University
265 CTB, Provo, UT 84602



*Toter Resin Supplier
Reference*

Mr. Bob Banks
National Account Manager
LyondellBassell / Equistar Chemicals, LP
Robert.banks@lyondellbasell.com
Phone: 678-574-6144
www.lyondellbasell.com



Toter, LLC Certification
Resin for Carts for the City and County of Denver, Co

Toter certifies that the City of Denver Carts will contain post-consumer recycled resin in carts at a minimum of 10% by weight. Toter will include the following percentages of recycled resin in Denver's carts, with amounts to be subject to availability of acceptable recycled resin materials at time of production.

	Black Body/ Lid	Green Body/ Lid	Purple Body/ Black Lid	Wheels
Post-Consumer	15%	15%	15%	0%
Pre-Consumer	15%	5%	5%	0%
Virgin	70%	80%	80%	0%

Sources of Resin:

- Post-Consumer - Post-Consumer Recycled Resin Suppliers
- Pre-Consumer - Toter Internal
- Virgin - Virgin Resin Suppliers

Certified by:

Toter, LLC



 Laura P. Hubbard – Director, Customer Relations

7-22-2015

Petrothene

GA635962

lyondellbasell

Linear Low Density Polyethylene
Rotational Molding Grade

Melt Index 6.7 Density 0.935

Applications Petrothene GA635962 is a high flow hexene LLDPE resin selected by customers for the rotational molding of large hollow objects, including toys, playground equipment, drums and agricultural and chemical storage containers. GA635962 exhibits high ESCR, low temperature impact strength and warp resistance. GA635962 is UV-stabilized and available in a 35-mesh powder as *Microthene* MP635962.

Processing Techniques Specific recommendations for conditions under which GA635962 should be processed can be made only when the end use and type of processing equipment are known. For further suggestions, please contact your Equistar sales representative.

Typical Properties	Property	Nominal Value	Units	ASTM Test Method
	Melt Index	6.7	g/10 min	D1238
	Density	0.935	g/cc	D1505
	ESCR, Condition A, F ₅₀ 100% Igepal®, CO-630	>1,000	hrs	D1693
	Flexural Modulus, 1 % Secant	107,000	psi	D790
	Flexural Modulus, 2 % Secant	91,000	psi	D790
	Tensile Strength @ Yield ¹	2,700	psi	D638
	Deflection Temperature at Load			
	@ 66 psi	57	°C	D648
	@ 264 psi	39	°C	D648
	Low Temperature Impact (-40°F)			
	1/8" specimen	40	ft-lbs	ARM*
	1/4" specimen	145	ft-lbs	ARM*

¹ Crosshead speed – 2 in/ min

* Association of Rotational Molders (ARM) International Test Protocol

® Igepal is a registered trademark of the Rhone-Poulenc Co., Inc.

Typical properties; not to be construed as specifications.

LyondellBasell markets this product through the following entities:

Equistar Chemicals, LP
Basell Sales & Marketing Company B.V.
Basell Asia Pacific Limited
Basell International Trading FZE
LyondellBasell Australia Pty Ltd

Microthene and *Petrothene* are trademarks owned or used by the LyondellBasell family of companies. *Microthene* and *Petrothene* are registered in the U.S. Patent and Trademark Office.

Before using a product sold by a company of the LyondellBasell family of companies, users should make their own independent determination that the product is suitable for the intended use and can be used safely and legally. SELLER MAKES NO WARRANTY; EXPRESS OR IMPLIED (INCLUDING ANY WARRANTY OF MERCHANTABILITY OR FITNESS FOR A PARTICULAR PURPOSE OR ANY WARRANTY) OTHER THAN AS SEPARATELY AGREED TO BY THE PARTIES IN A CONTRACT.

This product(s) may not be used in:

- (i) any U.S. FDA Class I, Health Canada Class I, and/or European Union Class I medical devices, without prior notification to Seller for each specific product and application; or
- (ii) the manufacture of any of the following, without prior written approval by Seller for each specific product and application: U.S. FDA Class II Medical Devices; Health Canada Class II or Class III Medical Devices; European Union Class II Medical Devices; film, overwrap and/or product packaging that is considered a part or component of one of the aforementioned medical devices; packaging in direct contact with a pharmaceutical active ingredient and/or dosage form that is intended for inhalation, injection, intravenous, nasal, ophthalmic (eye), digestive, or topical (skin) administration; and tobacco related products and applications. Additionally, the product(s) may not be used in: (i) U.S. FDA Class III Medical Devices; Health Canada Class IV Medical Devices; European Class III Medical Devices; (ii) applications involving permanent implantation into the body; (iii) life-sustaining medical applications; and (iv) lead, asbestos or MTBE related applications. All references to U.S. FDA, Health Canada, and European Union regulations include another country's equivalent regulatory classification.

Users should review the applicable Material Safety Data Sheet before handling the product.

Equistar Chemicals, LP
1221 McKinney, Suite 700
P. O. Box 2583
Houston, Texas 77252-2583
(888) 777-0232
www.lyondellbasell.com

NOVAPOL[®] POLYETHYLENE

Product Data Sheet
Rotational Molding Resin

Melt Index 3.5
Density 0.938

NOVAPOL

FEATURES:

- Hexene copolymer
- Excellent impact
- Excellent ESCR

ADDITIVES:

- Processing antioxidants

APPLICATIONS:

- Large parts
- Agricultural storage tanks

Properties	ASTM (1)	Typical Values (2)	
		SI Units	English Units
Melt Index (3)	D 1238	3.5 g/10 min	
Density	D 792	0.938 g/cm ³	
Melting Point		129 °C	264 °F
Crystallization Temperature		114 °C	237 °F
% Crystallinity		56 %	56 %
Molded Plaque Properties			
Tensile Strength @ Yield	D 638	20.6 MPa	3 000 psi
Tensile Strength @ Break		D 638 29.1	MPa 4 200
Elongation @ Yield	D 638	12 %	12 %
Elongation @ Break	D 638	1 000 %	1 000 %
Flexural Modulus	D 790	702 MPa	102 000 psi
Izod Impact Resistance (4)	D 256	182 J/m	3.4 ft-lb/in
Tensile Impact Strength	D 1822	145 kJ/m ²	69.1 ft-lb/in ²
ARM Impact (5)		74.5 J/m	55 ft-lb/in
Softening Point (Vicat)	D 1525	122 °C	252 °F
Heat Deflection Temperature (6)	D 648	58 °C	136 °F
ESCR, F ₅₀ 100% IGE PAL(7)	D 1693	>1 000 hr	>1 000 hr
ESCR, F ₅₀ 10% IGE PAL (7)	D 1693	30 hr	30 hr

(1) Properties designated have been determined in accordance with the current issues of the specified testing methods.

Methods of the American Society for Testing and Materials (ASTM) are used wherever applicable.

(2) Typical Values represent average laboratory values and are intended as guides only, not as specifications.

(3) Condition 190/2.16.

(4) 125 mil sample, notched.

(5) Association of Rotational Molders, -40°C, 3.2 mm (0.125 in).

(6) @ 66 psi.

(7) Environmental stress crack resistance, Condition A.

TI-0338-A

MDPE

NOVAPOL[®] POLYETHYLENE

AVAILABILITY

NOVAPOL polyethylene resins are available in bulk hopper cars, hopper trucks, boxes, sea bulk containers or bags. The product type and batch number are clearly marked on each container. Contact the NOVA Chemicals sales office nearest you for availability in your area.

STORAGE/HANDLING

TI-0338-A should be stored in a clean, dry place at ambient temperatures. Prolonged or improper storage can result in deterioration of product properties. Care should be taken when handling and transferring product to prevent foreign matter contamination. The NOVA Chemicals material safety data sheet (MSDS) contains important safety information and should be reviewed before using the product.

PROCESSING CONDITIONS

Comprehensive assistance with processing conditions and technology is available from NOVA Chemicals Technical Service.

FOOD PACKAGING STATUS

Canada: NOVA Chemicals Ltd. has not submitted TI-0338-A to HPB for an opinion on its use in Canada for food packaging applications. Please contact your NOVA Chemicals Technical Service representative for information on the use of this resin in the packaging of specific foodstuffs.

United States: TI-0338-A complies with the specifications contained in the U.S. Food and Drug Administration (FDA) regulation 21 CFR 177.1520 for olefin polymers, para. (c) 3.2a, and may thus be used in the United States as an article or component of an article intended for use in contact with food.

Other Countries: For regulatory compliance information for other countries, please contact your nearest NOVA Chemicals office.

ENVIRONMENTAL

NOVA Chemicals' polyethylene resins are biologically and chemically inert, but improper disposal may present an ingestion hazard to wildlife. Where recycling of NOVA Chemicals' polyethylene resins is not possible, disposal to landfill or incineration in accordance with all applicable government laws and regulations is recommended. Please contact NOVA Chemicals Technical Service for further information on recycling and disposal of NOVA Chemicals resins.



LDPE is the SPI resin code developed for low density and linear low density polyethylene to identify material type for sorting and recycling purposes.

NOVA Chemicals Technical
Centre
3620 - 32 Street N.E.
Calgary, Alberta
Canada T1Y 6G7

Tel: 403-291-8444
Fax: 403-291-0493

NOVA Chemicals Ltd.
Head Office
645 Seventh Avenue S.W.
P.O. Box 2535, Station M
Calgary, Alberta
Canada T2P 2N6

Tel: 403-750-3600
Fax: 403-269-7410

NOVA Chemicals Ltd.
2nd Floor
6711 Mississauga Road
Mississauga, Ontario
Canada L5N 2W3

Tel: 905-542-3338
Toll Free: 1-800-263-2581
Fax: 905-542-8075

NOVA Chemicals Ltd.
1250, boul. René-Lévesque
Ouest
Bureau 2200
Montréal, Quebec
Canada H3B 4W8

Tel: 514-989-3120
Fax: 514-989-3123

NOVA Chemicals Inc.
Parkwest II, Suite 200
2000 Cliff Mine Road
Pittsburgh, PA 15275
USA

Tel: 412-490-4000
Toll Free: 800-222-7213
Fax: 412-494-4861

NOVA Chemicals
(International) S.A.
(Int'l Head Office)
Route De La Glâne 107
CH-1752 Villars-aux-Grânes
Switzerland
HAR 2J8

(Reception and Polymers
Marketing)
Tel: 41-26-409-73-05
Fax: 41-26-409-73-20
(Europe and Africa Sales)
Fax: 41-26-409-73-26



is a registered trademark of NOVA Brands Ltd, authorized use.

NOVAPOL[®] is a trademark of NOVA Brands Ltd, authorized use

All information is furnished in good faith, without warranty, representation, inducement or a license of any kind. No guarantee is given that NOVA Chemicals' products will be suitable in purchasers' formulations or processes for any particular end use



Association of Rotational Molders

July 16, 1998



RECYCLABILITY STATEMENT

All of the components utilized in Toter containers are fully (100%) recyclable into products of a like or similar nature. This degree of recyclability is known in the industry as "primary recyclability." This will allow the option to either sell the recyclable materials back to the contractor at the conclusion of the contract or sell them into the plastics/steel commodity markets.

A handwritten signature in cursive script that reads "Laura Hubbard".

July 21, 2015

Laura P. Hubbard - Director, Customer Relations

Toter®

Original Purchaser: _____

Date of Purchase: _____

MANUFACTURER'S DIRECT WARRANTY Toter® Container

Toter, LLC (Toter) warrants its Container Body (molded plastic) to the original purchaser, listed above, to be free of operational defects in material and workmanship under normal use and service for a period of ten years from the Date of Purchase. Container components (lids, wheels, axle, and fasteners) are warranted under the same stated conditions for a period of ten years from the Date of Purchase. This warranty equally covers Toter containers molded of either virgin resin or recycled content plastic materials.

This warranty is expressly limited to any product parts which are proven to Toter's satisfaction to be defective under this warranty. Toter retains the right to inspect components submitted for warranty to confirm that their failure is covered by this warranty. Repaired or replaced parts are warranted for the balance of the original warranty period of the original part. Replaced parts may, in Toter's discretion, be similar to or identical to original defective parts. Toter limits specialty color lid replacements to 10% of the original ordered amount, the remaining replacement lids shall be of a standard color, subject to Toter's discretion. Repair, replacement or a limited-use credit are the sole remedies available under this warranty. The applicability and scope of any remedy is in Toter's discretion. This warranty is non-transferrable, and customer assumes all risk and liability for freight, handling, use, storage or application of the Container. Toter is responsible for freight charges.

Toter shall be promptly notified of any failures under warranty in order that such failures may be inspected. If Purchaser and Toter disagree regarding the reason for failure, then they shall select a technically competent party skilled in the use and fabrication of the materials involved and shall ask for determination on the source of the failure. The determination shall be binding on both parties. This third party procedure shall not be used for isolated, one-time failures, but only in the event a major failure trend develops. Expenses of third party determination shall be borne by the party that is determined to be liable for the replacement.

Specifically excluded from this warranty are labor and installation charges, alterations, and damages due to negligent or abusive use or normal wear and tear, including, but not limited to, those items listed on Schedule A (on back hereof). Alterations, negligent, abusive, or specifically excluded use of container voids this warranty thereafter. In no event shall Toter be liable for incidental, special, punitive, liquidated or consequential damages, for loss of product or time, or for any delay in performance under this warranty.

At its sole discretion, Toter may collect defective components replaced under the terms of this warranty. Customer is not to dispose of, sell, or recycle components that have been replaced by Toter without written permission from Toter. Components not collected by Toter remain the property of the customer.

EXCEPT FOR THE WARRANTY CONTAINED IN OUR TERMS AND CONDITIONS OF SALE, TOTER MAKES NO WARRANTY WHATSOEVER WITH THE RESPECT TO THE GOODS INCLUDING, ANY WARRANTY OF MERCHANTABILITY, WARRANTY OF FITNESS FOR A PARTICULAR, SPECIFIED OR INTENDED PURPOSE, WHETHER EXPRESSED OR IMPLIED BY LAW, COURSE OF DEALING, COURSE OF PERFORMANCE, USAGE OF TRADE, OR OTHERWISE (where permitted by law).

This document is only a summary of the full Wastequip Product Limited Warranties, Disclaimers Of Warranties, Limitation Of Liabilities And Remedies, and Limited Warranty Periods statement. Full warranty details can be found on www.toter.com. If this summary and the full warranty documents conflict, the summary will supersede on where more narrowly defined.

SCHEDULE A

Toter Containers are designed for storage, transport, and dumping of normal household residential solid wastes, recyclables, and yard waste, excluding circumstances in which the load rating would be exceeded.

Following are descriptions of several situations where the warranty does not apply. Exclusion is not limited to these situations.

EXAMPLES OF NORMAL WEAR AND TEAR:

- * Scratches - normal use may cause scratches.
- * Dirt, including accumulation of dirt or any other substance.
- * Normal deterioration during service.
- * Normal discoloration due to atmospheric exposure.

EXAMPLES OF ALTERATIONS, NEGLIGENT OR ABUSIVE USE:

- * Alteration of the original design, functionality or integrity of the Container
- * Cuts or scores from any source.
- * Extraordinary impacts such as being hit by a vehicle.
- * Burns, scorches, melting, or any damage from excessive heat.
- * Improper handling, including dropping stacks off delivery trucks, improper stacking, improper /excessive storage, forcing cart through narrow openings, allowing packer mechanism to hit cart or lid during dumping cycle, abrasion from excessive dragging, or cracks caused by improper handling or dumping.
- * Damage from automated grasper or semi-automated lifter, including any scratches, creases, cracks or breaks from a maladjusted, incorrectly operated, or improper automated grasper or semi-automated lifter. Includes any semi-automated lift speed faster than ANSI specifications for either the lift cycle or the down cycle.
- * Chemicals - being exposed to solvents, petrochemicals, paints, acids, or other chemical substance which damages plastic or metal parts.
- * Failure to follow instructions imprinted on cart parts (i.e., exceeding stated maximum load rating.)