

STANDARD FOOD AND BEVERAGE CONCESSION SPACE AGREEMENT

BETWEEN

THE CITY AND COUNTY OF DENVER

AND

**CI/EL-ROI RMCF, JV
DBA ROCKY MOUNTAIN CHOCOLATE FACTORY**

**AT
DENVER INTERNATIONAL AIRPORT**

PREPARED 9/26/2013

STANDARD FOOD AND BEVERAGE CONCESSION SPACE AGREEMENT

DENVER INTERNATIONAL AIRPORT

SUMMARY PAGE

CI/EL-ROI RMCF, JV

This Summary Page, consisting of three (3) pages, is attached to and made a part of that certain Agreement made and entered into as of the date stated on the signature page, between the City and County of Denver and the Concessionaire listed below.

CONCESSIONAIRE: Name	CI/EL-ROI RMCF, JV
Address for Notices	566 Wells St., SW,
City, State and Zip	Atlanta, GA 30312
Contact	Anthony Joseph
Trade Name	Rocky Mountain Chocolate Factory
State of Incorporation	Colorado

CONCESSION LOCATION AND COMPENSATION (INITIAL)						
Loca. Num.	Concourse /Terminal	Address	Square Feet	Initial Monthly Guarantee	Minimum Investment PSF	
1	Concourse B West Outboard Subcore	R18-1-3-E36-S5- 1	816.70	\$ 14,022.74	\$ 450.00	

PERCENTAGE COMPENSATION FEE: 13% of Gross Revenues as defined in §5.02.

PERFORMANCE SURETY AMOUNT: \$84,136.00 or as provided in Section 9.03

MARKETING ASSESSMENT: 1.00% of Gross Revenues as provided in §5.03.

STORAGE SPACE LEASE: n/a To be mutually agreed to under a separate agreement

EFFECTIVE DATE: Date agreement is entered into as of the date stated on the signature page.

EXPIRATION DATE: Last day of the month 7 years from the Required Opening Date or as modified by §§4.01, 4.02, or *Exhibit D*.

PERMITTED USE:

Operation of a first-class Food and Beverage concession at DIA, offering for sale only the following items:

Rocky Mountain Chocolate Factory branded bulk candy, chocolate confections, frozen desserts such as dipped cones and sundaes, candied apples, boxed candies, dipped fruits, bottled sodas and water.,

Examples of Permitted Uses are listed in ***Exhibit E, Initial Proposed Items and Pricing.***

Express Restrictions:

Unless otherwise authorized in writing by the Manager or the Manager's Authorized Representative, Concessionaire may not sell the following expressly restricted items:

Any items not contained in the Permitted Uses and Specialty or gourmet coffees (defined as hot, cold and frozen espresso based beverages or other flavored coffees, i.e. cappuccino, mochas, latte etc.), meals, and popcorn.

Major Concession Category

Food and Beverage

Minor Concession Category

Snack

Concessionaire's Brand(s)

Rocky Mountain Chocolate Factory

HOURS OF OPERATION:

Not less than sixteen (16) hours each day, seven (7) days per week, or as they may be adjusted pursuant to §7.04.

PRELIMINARY DESIGN DUE DATE:

30 calendar days from the Effective Date or as documented by ***Exhibit D.***

NTP DOCUMENTS DEADLINE:

150 calendar days from the Effective Date or as documented by ***Exhibit D.***

TARGET POSSESSION DATE:

180 calendar days from the Effective Date or as documented by ***Exhibit D.***

REQUIRED OPENING DATE:

300 calendar days from the Effective Date or as documented by ***Exhibit D.***

RENT COMMENCEMENT DATE:

300 calendar days from the Effective Date or as provided by §5.03 and documented by ***Exhibit D.***

REQUIRED MINIMUM INVESTMENT:

\$367,515 (816.70 s.f. x \$450)

RENOVATION MINIMUM INVESTMENT:

\$73,503

RENOVATION COMPLETION DATE(S):

42 months from the Rent Commencement Date or As provided in §7.09 and documented by ***Exhibit D.***

INSURANCE POLICY AMOUNTS:

See, ***Exhibit C.***

ACDBE GOAL:

40 %

DESCRIPTION OF EXHIBITS, AND APPENDICES:

Exhibit A	Concession Space Plan
Exhibit B	Disadvantaged Business Enterprise Participation
Exhibit C	Insurance Certificate
Exhibit D	Confirmation of Actual Dates and Term
Exhibit E	Initial Proposed Items and Prices
Exhibit F	Comparable Street Pricing
Exhibit G	ACDBE Commitment Form
Exhibit H	Removed Intentionally
Exhibit I	Concession Revenue Monthly Report Form
Exhibit J	DIA Environmental Requirements
Exhibit X	Provisions for Design and Construction of Improvements
Appendix 1	Standard Federal Assurances and Nondiscrimination
Appendix 2	Disadvantaged Business Enterprises - Required Statements

Table of Contents

SECTION 1 – GENERAL	1
1.01. CONSIDERATION	1
1.02. INCORPORATION OF ATTACHED SUMMARY PAGE, EXHIBITS, AND ADDENDA	1
SECTION 2 – ADMINISTRATION OF AGREEMENT	1
2.01. MANAGER; MANAGER’S AUTHORIZED REPRESENTATIVE	1
SECTION 3 – GRANT OF CONCESSION RIGHTS	2
3.01. CONCESSION RIGHTS GRANTED	2
3.02. USE OF SPACE.....	2
3.03. RIGHTS NOT EXCLUSIVE	2
3.04. MEANS OF ACCESS.....	2
3.05. CITY’S RIGHT OF ACCESS	3
SECTION 4 – TERM	3
4.01. TERM.....	3
4.02. DELIVERY OF THE CONCESSION SPACE	3
4.03. CONFIRMATION OF DATES.....	4
4.04. HOLDING OVER.....	4
SECTION 5 – COMPENSATION	5
5.01. COMPENSATION	5
5.02. GROSS REVENUES.....	6
5.03. MONTHLY PAYMENTS AND REVENUE STATEMENTS	6
5.04. TITLE TO CITY’S COMPENSATION	7
5.05. INTEREST ON PAST DUE AMOUNTS.....	8
5.06. PLACE AND MANNER OF PAYMENTS	8
5.07. APPLICATION OF PAYMENTS	8
5.08. BOOKS OF ACCOUNT AND AUDITING.....	8
5.09. REESTABLISHMENT OF RENTALS, FEES, AND CHARGES	11
SECTION 6 – DESIGN, CONSTRUCTION, AND INSTALLATION OBLIGATIONS	11
6.01. ACCEPTANCE OF THE CONCESSION SPACE.....	11
6.02. CONSTRUCTION OBLIGATIONS OF CONCESSIONAIRE	11
SECTION 7 - OPERATION AND USE	13
7.01. OPERATING A FIRST CLASS CONCESSION.....	13
7.02. BRANDS.....	16
7.03. CREDIT CARDS AND DEBIT CARDS.....	16
7.04. HOURS OF OPERATION	17
7.05. CARE OF AREA	17
7.06. SALES AND DIGNIFIED USE	17
7.07. VENDING MACHINES	17
7.08. MAINTENANCE OF A FIRST-CLASS CONCESSION SPACE	18

7.09.	RENOVATION OF CONCESSION SPACE.....	19
7.10.	TITLE TO IMPROVEMENTS.....	20
7.11.	SURRENDER OF CONCESSION SPACE.....	20
7.12.	REMOVAL OF CONCESSIONAIRE'S EQUIPMENT.....	20
7.13.	DAMAGE CAUSED TO OTHER PROPERTY.....	21
7.14.	COMPLIANCE WITH ALL LAWS AND REGULATIONS.....	21
7.15.	COMPLIANCE WITH ENVIRONMENTAL REQUIREMENTS.....	22
7.16.	WASTE OR IMPAIRMENT OF VALUE.....	22
7.17.	HAZARDOUS USE.....	22
7.18.	STRUCTURAL, ELECTRICAL, OR SYSTEM OVERLOADING.....	22
7.19.	NOISE, ODORS, VIBRATIONS, AND ANNOYANCES.....	23
7.20.	ACCESSIBILITY.....	23
SECTION 8 – UTILITIES AND SERVICES.....		23
8.01.	UTILITIES.....	23
8.02.	HEATING AND AIR CONDITIONING (HVAC).....	24
8.03.	WATER SERVICE.....	24
8.04.	ELECTRICITY AND NATURAL GAS.....	24
8.05.	LIGHTING.....	24
8.06.	WINDOW WASHING AND STRUCTURAL MAINTENANCE.....	24
8.07.	COMMON USE SERVICES.....	25
8.08.	INTERRUPTION OF SERVICES.....	25
SECTION 9 – INDEMNITY AND INSURANCE AND GUARANTEES.....		25
9.01.	INDEMNITY.....	25
9.02.	INSURANCE.....	25
9.03.	PERFORMANCE SURETY.....	27
9.04.	UNCONDITIONAL GUARANTEE [RESERVED].....	29
9.05.	NO PERSONAL LIABILITY.....	29
9.06.	TAXES, LICENSES, LIENS, AND FEES.....	29
SECTION 10 - FAILURE TO OPERATE AND MAINTAIN A FIRST-CLASS CONCESSION ...		30
10.01.	MANAGER'S OBJECTIONS.....	30
10.02.	REMEDICATION OF OPERATIONAL DEFICIENCIES.....	30
SECTION 11 –DEFAULT AND REMEDIES.....		31
11.01.	DEFAULT.....	31
11.02.	REMEDIES.....	33
11.03.	REMEDIES CUMULATIVE.....	35
11.04.	WAIVER.....	35
11.05.	ADMINISTRATIVE HEARING.....	35
SECTION 12 – DAMAGE, DESTRUCTION, OR LOSS.....		35
12.01.	DAMAGE TO OR DESTRUCTION OF CONCESSION SPACE.....	35
12.02.	COOPERATION IN THE EVENT OF LOSS.....	35
12.03.	LOSS OR DAMAGE TO PROPERTY.....	36
12.04.	MUTUAL WAIVER/INSURANCE COVERAGE.....	36

SECTION 13 – PROMOTIONAL PROGRAM	36
13.01. JOINT MARKETING FUND	36
13.02. PREMIUM VALUE CONCESSIONS PROGRAM	37
SECTION 14 – MISCELLANEOUS PROVISIONS	37
14.01. ADVERTISING AND PUBLIC DISPLAYS	37
14.02. AGREEMENT BINDING UPON SUCCESSORS.....	37
14.03. AGREEMENT MADE IN COLORADO; VENUE.....	38
14.04. AGREEMENT SUBORDINATE TO-AGREEMENTS WITH THE UNITED STATES.....	38
14.05. RIGHT TO DEVELOP AIRPORT	38
14.06. MASTER PLAN	38
14.07. AGREEMENT SUBJECT TO AVIATION PRIORITY.....	38
14.08. BOND ORDINANCES.....	39
14.09. EARLY TERMINATION	39
14.10. FORCE MAJEURE	39
14.11. INCONVENIENCES DURING CONSTRUCTION.....	40
14.12. ASSIGNMENT AND SUBLEASE.....	40
14.13. NONDISCRIMINATION.....	40
14.14. NOT PARTNERSHIP	41
14.15. NOTICES	41
14.16. PARAGRAPH HEADINGS.....	41
14.17. PATENTS AND TRADEMARKS.....	41
14.18. COLORADO OPEN RECORDS ACT	42
14.19. SECURITY	42
14.20. SEVERABILITY	43
14.21. THIRD PARTIES.....	43
14.22. AUTHORITY TO ENTER INTO AGREEMENT.....	44
14.23. NO CONSTRUCTION AGAINST DRAFTING PARTY	44
14.24. USE, POSSESSION, OR SALE OF ALCOHOL OR DRUGS.....	44
14.25. CITY SMOKING POLICY.....	44
14.26. WAIVER OF CLAIMS	45
14.27. JOINT AND SEVERAL LIABILITY	45
14.28. BROKER'S COMMISSION	45
14.29. NO LIMIT ON CITY'S POWERS	45
14.30. WAR OR NATIONAL EMERGENCY	45
14.31. SURVIVAL OF CERTAIN CONTRACT PROVISIONS.....	45
14.32. AGREEMENT AS COMPLETE INTEGRATION; AMENDMENTS	45
14.33. FINAL APPROVAL; COUNTERPARTS; ELECTRONIC SIGNATURES	46

STANDARD FOOD AND BEVERAGE CONCESSION SPACE AGREEMENT

THIS STANDARD FOOD AND BEVERAGE CONCESSION SPACE AGREEMENT ("Agreement") is entered into as of the date stated on the signature page, by and between the **CITY AND COUNTY OF DENVER**, a municipal corporation of the State of Colorado, for and on behalf of its Department of Aviation (the "City"), Party of the First Part, and **CI/EL-ROI RMCF, JV**, a joint venture between **Concessions International, LLC**, a Colorado limited liability company and **Muluye Haileemariam dba EI-ROI Jewelry Fashion**, a Colorado resident and sole proprietor ("Concessionaire"), d/b/a **Rocky Mountain Chocolate Factory**, Party of the Second Part (collectively, the "Parties").

SECTION 1 – GENERAL

1.01. CONSIDERATION

The City owns, operates, and maintains Denver International Airport ("DIA" or the "Airport"). Acting pursuant to a competitive solicitation process in which Concessionaire was recommended to operate a first-class concession at the Airport, the City enters into this Agreement for and in consideration of the payment of compensation by Concessionaire as herein provided, the timely construction and completion by Concessionaire of all Improvements as defined in **Exhibit X**, the operation of a business using Concessionaire's Brand and the performance and observance by Concessionaire of the terms, conditions, requirements, covenants, and agreements herein.

1.02. INCORPORATION OF ATTACHED SUMMARY PAGE, EXHIBITS, AND ADDENDA

The Summary Page, the Exhibits, and Addenda attached to this Agreement, as described on the Summary Page, and all Airport Rules and Regulations, as defined in §7.14, are incorporated into this Agreement. In addition, the Summary Page, as well as, **EXHIBITS A, D, E, F, and I** may be modified from time to time as provided herein without the requirement of a formal amendment to this Agreement.

SECTION 2 – ADMINISTRATION OF AGREEMENT

2.01. MANAGER; MANAGER'S AUTHORIZED REPRESENTATIVE

The City's Manager of Aviation or the Manager's successor in function under the Denver Charter ("Manager"), exercises the City's authority and discretion under this Agreement. Whenever reference is made herein to the "Manager or the Manager's Authorized Representative," or words of similar import are used, the City's Deputy Manager of Aviation/Commercial shall be such authorized representative of the Manager, unless written notice is otherwise given to Concessionaire by the Manager. The Deputy Manager's Authorized Representative is the Airport's Concessions Director who designates the Airport's Concessions Administration Manager for day-to-day administration of this Agreement. Concessionaire shall submit its reports, memoranda, correspondence, and submittals to the Concessions Administration Manager, except as otherwise provided herein. The Manager and the Deputy Manager may rescind or amend any such designation of representatives or delegation of City authority upon written notice to Concessionaire.

SECTION 3 – GRANT OF CONCESSION RIGHTS

3.01. CONCESSION RIGHTS GRANTED

Consistent with and subject to all the terms, conditions, covenants, and provisions of this Agreement, the City grants to Concessionaire the right to occupy, improve, and use the Concession Space as of the Delivery Date, as defined in §4.02 and documented by **Exhibit D**. As used in this Agreement, “Concession Space” shall mean that space located within the Jeppesen Terminal at the Airport (“Terminal”), the South Terminal at the Airport (“South Terminal”), and/or the Concourses A, B, or C at the Airport (collectively the “Concourses”) as generally depicted and containing the number of square feet set forth on the Concession Space Plan attached hereto as **Exhibit A**. The City and Concessionaire acknowledge and agree that the dimensions of the Concession Space are approximate and that after completing construction, the precise dimensions and square footage shall be determined by the City and a revision to **Exhibit A** will be made, if necessary, depicting the dimensions and square footage of the Concession Space as actually constructed. In addition, the City may add or subtract square footage of up to twenty percent (20%) of the Concession Space with Concessionaire’s prior written consent.

3.02. USE OF SPACE

Concessionaire may use the Concession Space only to operate a first-class concession offering for sale the authorized items set forth in the Permitted Use clause of the Summary Page. Concessionaire covenants and agrees to operate its concession in strict conformance with the Permitted Use clause and for no other purpose unless and until otherwise authorized in writing by the Manager or the Manager’s Authorized Representative. Concessionaire understands and agrees that the use of the Concession Space is restricted by all applicable rules, regulations, statutes, or ordinances promulgated by any federal, state, or municipality having jurisdiction over the Airport. (Note: “item” or “items” generally refer to anything Concessionaire is authorized to sell and should be construed to be consistent with the Major and Minor Concession Categories listed on the Summary Page, examples of which include services, retail, or food and beverage (with or without alcohol).

3.03. RIGHTS NOT EXCLUSIVE

The City reserves the right to grant to other concessionaires the right to operate a business and sell items in other locations in the Airport that are the same, similar, or even identical to those described on the Summary Page. Concessionaire understands and agrees that its right to operate its business at the Airport and/or sell any of the items described on the Summary Page is not exclusive.

3.04. MEANS OF ACCESS

Concessionaire, its agents, invitees, guests, employees, contractors and suppliers have a non-exclusive right of ingress to and egress from the Concession Space by a means of access located outside the boundaries of such space as specified by the City. Such access shall, without exception, be in common with such other persons (including, at the option of the City, the general public) as the City may authorize or permit. The City may at any time close, relocate, reconstruct, or modify such means of access, provided that a reasonably convenient and adequate means of ingress and egress is available for the same purpose. This right of

access is subject to the security requirements of §14.19. Moreover, without exception, nothing in this Agreement shall be construed to prevent the City from charging the operators of vehicles carrying passengers and property a fee for the privilege of entering upon the Airport; using the roadways in or on the Airport; soliciting passengers upon the Airport; or otherwise operating on the Airport. The City reserves the right to make such charges provided that they do not discriminate unreasonably against the operators of vehicles used for carrying officers, employees, passengers, or property of Concessionaire.

3.05. CITY'S RIGHT OF ACCESS

With or without advance notice, without liability, and without in any manner affecting Concessionaire's obligations under this Agreement, the City retains the full right of entry in and to the Concession Space in the exercise of its governmental functions, for the purpose of making any inspection it deems necessary, or for any purpose necessary, incidental to, or in connection with its rights or obligations hereunder. During the last eighteen (18) months of the Term (or any extended term) of this Agreement, the City may show the Concession Space to prospective tenants. In addition, during any emergency, the City, or its agents, may enter the Concession Space forcibly, if necessary. No such reasonable entry by or on behalf of the City upon the Concession Space shall constitute or cause a termination of this Agreement by Concessionaire.

SECTION 4 – TERM

4.01. TERM

A. Term. As set forth on the Summary Page, this Agreement shall be effective and binding on the Effective Date and shall expire on the Expiration Date unless terminated earlier or extended and documented on **Exhibit D** as provided herein. "Term" as used in this Agreement is a general reference to the period from and including the Rent Commencement Date to and including the Expiration Date.

B. Early Opening Incentive. If, before the Required Opening Date, Concessionaire Opens for Business as defined in §6.02, then Concessionaire shall commence paying one half of the total Compensation payable to the City as provided in §5.01C. Additionally, the time between the Required Opening Date and the date Concessionaire Opens for Business shall be added to the Expiration Date and documented on **Exhibit D**.

4.02. DELIVERY OF THE CONCESSION SPACE

A. Target Possession Date. The "Target Possession Date" is a nonbinding estimate of the date the City plans to deliver possession of the Concession Space to Concessionaire. The City will give Concessionaire written notice when the City is ready to deliver possession of the Concession Space for Concessionaire's use and occupancy. The date as specified in any such written notice (the "Delivery Date") shall be considered the date actual possession of the Concession Space is delivered to Concessionaire. If possession of the Concession Space is delivered to Concessionaire after the Target Possession Date, the amount of time between the Target Possession Date and the Delivery Date shall be added to the NTP Documents Deadline, Required Opening Date, Rent Commencement Date, Renovation Completion Date, and Expiration Date. With Concessionaire's consent, the Delivery Date may occur no more than thirty (30) calendar days earlier than the Target Possession Date, but such early delivery of

possession shall not affect the NTP Documents Deadline, Required Opening Date, Renovation Completion Date, or the Expiration Date. If for any reason the City does not deliver possession of the Concession Space to Concessionaire on or after the Target Possession Date, the City shall not be subject to any liability therefor. Such failure to deliver possession of the Concession Space by the time provided for in this Agreement will not give rise to any claim for damages by Concessionaire against the City or against the City's contractor; nor shall such failure affect the validity of this Agreement or Concessionaire's obligations hereunder.

B. City's Option to Terminate. If for any reason the City fails to deliver possession of the Concession Space to Concessionaire within six (6) months after the Target Possession Date, then the City, in the sole and absolute discretion of the Manager, shall have the option at any time thereafter to notify Concessionaire in writing of the City's intent to terminate the Agreement. In such event, the Agreement shall terminate on the date as stated in said notice, and both the City and Concessionaire shall be released from any liability or obligation under the Agreement.

C. Concessionaire's Option to Terminate. If for any reason the City has not terminated this Agreement or delivered possession of the Concession Space to Concessionaire within nine (9) months after the Target Possession Date, then Concessionaire, at any time thereafter, may notify the City in writing of Concessionaire's intent to terminate the Agreement sixty (60) days after the City receives written notice. This Agreement, however, shall remain in full force and effect if the City delivers possession of the Concession Space within that sixty (60) day period. If the City has not delivered possession of the Concession Space to Concessionaire within the sixty (60) day notice period, this Agreement shall terminate at the close of business on the sixtieth (60th) day, and both the City and Concessionaire shall be released from any liability or obligation under the Agreement.

4.03. CONFIRMATION OF DATES

The Parties acknowledge that the Required Opening, Rent Commencement, Renovation Completion, Expiration Dates, Preliminary Design Due Date, and the NTP Documents Deadline as listed on the Summary Page are all calculated based on the Effective Date, which cannot be determined until this Agreement is fully executed. Because these dates are material to this Agreement, promptly after execution of this Agreement, the City will confirm the Effective Date and deliver to Concessionaire a written confirmation of the referenced dates substantially in the form of **Exhibit D**. Following the Rent Commencement Date, the Parties shall execute a final confirmation of all dates in a written statement substantially in the form of **Exhibit D**. If Concessionaire fails to execute the final confirmation within twenty (20) days after it is delivered to Concessionaire, then absent manifest error, the dates set forth by the City in its final confirmation will be deemed to be accurate under this Agreement for all purposes. **Exhibit D** may be modified by the Manager as permitted herein without formally amending this Agreement.

4.04. HOLDING OVER

A. Tenancy at Sufferance. Concessionaire's tenancy shall be at sufferance if Concessionaire remains in possession of the Concession Space after the Expiration Date, any extension of the Term, or earlier termination of this Agreement, and the City and Concessionaire have not otherwise agreed in writing (as described below in §4.04B). Tenancy at sufferance shall be at a monthly compensation, payable in advance, equal to one hundred and fifty percent (150%) of the monthly Compensation provided for in §5.01, together with all other fees payable

hereunder of this Agreement. Concessionaire shall otherwise remain bound by all other terms, conditions, and covenants of this Agreement. The City will notify Concessionaire in writing that the tenancy is at sufferance. Thereafter, and without further notice, the City may exercise all remedies provided in this Agreement, at law, or in equity, to recover possession of the Concession Space. Tenant shall be liable to the City for all loss or damage incurred by the City on account of any such holding over.

B. Permitted Holding Over. The foregoing notwithstanding, the City may at its option give Concessionaire written permission to remain in possession of the Concession Space after expiration of the Term on a month-to-month basis. A month-to-month tenancy by Concessionaire shall be deemed permitted until either Party gives the other Party a thirty (30) day prior written notice of termination. It is agreed and understood that any holding over of Tenant after the expiration of this Agreement with the City's consent shall not renew or extend the Term. Concessionaire agrees to pay to the City in advance the monthly Compensation in effect at the end of the regular Term of the Agreement together with all other fees payable hereunder. Concessionaire agrees to remain bound by the terms, conditions, and covenants of this Agreement. Nothing herein shall be construed to give Concessionaire the right to hold over at any time, and the City (after expiration or termination of this Agreement, as the case may be) may exercise any and all remedies provided in this Agreement, at law, or in equity, to recover possession of the Concession Space, as well as any damages incurred by the City on account of such holding over.

SECTION 5 – COMPENSATION

5.01. COMPENSATION

A. Compensation Payment. As compensation for the rights and privileges herein granted by the City, Concessionaire covenants and agrees, without setoff, deduction, or abatement (except where abatement is expressly permitted in this Agreement), to pay the City the sum equal to the Monthly Guarantee as stated on the Summary Page and as it may be modified herein, plus the amount by which the Percentage Compensation Fee exceeds the Monthly Guarantee (sometimes collectively referred to as “Compensation” or “Rent”). Said obligation to pay Compensation shall commence upon the Rent Commencement Date and continue through the Term. Effective January 1st of each year following the first year after the Rent Commencement Date, the Monthly Guarantee for each calendar year shall be reset to an amount equal to eighty-five percent (85%) of the total of all Monthly Guarantees plus Percentage Compensation Fees payable to the City for the prior calendar year divided by twelve. Notwithstanding the foregoing, in no event shall the Monthly Guarantee be less than the Monthly Guarantee initially stated on the Summary Page.

B. Calculation of Percentage Compensation Fee. The Percentage Compensation Fee is calculated by multiplying the appropriate percentage rate(s) shown on the Summary Page times the Gross Revenue for each category and volume of sales as indicated on the Summary Page. The rate does not change until cumulative sales (calculated on a calendar year basis) exceed the threshold listed on the Summary Page. The volume of cumulative sales resets to zero on January 1st of each calendar year.

C. Early Opening Incentive. If Concessionaire Opens for Business before the Required Opening Date, Concessionaire shall pay one half of the total Compensation payable to the City

until the Required Opening Date. Beginning on the Required Opening Date, Concessionaire shall pay the entire amount of the total Compensation payable to the City as set forth above.

5.02. GROSS REVENUES

A. Gross Revenues Defined. As used herein, "Gross Revenues" shall mean all billings and receipts, from sales or services or doing business at the Concession Space or within the Airport, whether for cash or credit, gift certificates when redeemed, memberships, service contract, or otherwise; whether for retail or wholesale; whether from sales or services rendered by Concessionaire, another person, or any other entity in, at, or from the Concession Space, regardless of place or time of actual payment; uncollected amounts, credit card fees or charges, collection costs, method of collection, or whether any party other than Concessionaire is providing or operating equipment or services involved in the transaction, billing, or receiving revenue from such transaction.

B. Inclusive in Gross Revenues. Gross Revenues include, but are not limited to, all transactions, (i) whether placed or received in person, by telephone, fax, catalog, internet, or mail, (ii) whether occurring on the Concession Space or within the Airport, including all orders that originate in, at, or from the Concession Space, regardless of where delivery or performance is made, even if performed at cost or related to a service or management fee associated with providing goods and/or services to another tenant at the airport (e.g., an airline's preferred passenger club/lounge), (iii) whether selling promotional, display, or advertising space; and (iv) any other income resulting from transactions originating in, at, or from the Concession Space or within the Airport including promotional or advertising income received by or paid to Concessionaire in exchange for displays, promotions, advertising, or other business transacted at the Concession Space; discounts not excluded hereunder; and insurance proceeds received due to loss of gross earnings under business interruption coverage. Such insurance proceeds will be allocated equally for each covered month applying the appropriate rate, as listed on the Summary Page, to pay the Percentage Compensation Fee for each covered month in which the allocation of proceeds exceeds the Monthly Guarantee for that month. Gross Revenues shall not include deductions for any purpose except those items specifically exempted below.

C. Allowed Deductions from Gross Revenues. When properly recorded and accounted for, a reduction from Gross Revenues shall be allowed for the following: (i) bona fide returns for credit; (ii) refunds to customers, but only to the extent the original sale to that customer was included in Gross Revenues; (iii) sales of fixtures, machinery, and equipment after use in Concessionaire's business in the Concession Space; (iv) sales, excise, or similar taxes imposed by a governmental entity, collected from customers, and then directly paid by Concessionaire to the government entity; (v) tips and gratuities; (vi) advertised discounts, discounts given to employees displaying an Airport issued badge, and discounts given pursuant to Concessionaire's discount policy when approved by the City in writing; (vii) shipping and delivery charges if provided at cost and separately stated on customer invoices; (viii) loyalty cards; and (xi) marketing funds provided by suppliers in lieu of or as a discount for supplies purchased. There shall not be allowed from Gross Revenues any reduction for bad debts, loss from theft, or any other deduction except as described above.

5.03. MONTHLY PAYMENTS AND REVENUE STATEMENTS

A. Monthly Guarantee. Subject to the provisions of §5.01C, the Monthly Guarantee shall be payable by Concessionaire to the City in advance and without demand on the first day

of each calendar month, beginning on the date Concessionaire Opens for Business or the Required Opening Date (the "Rent Commencement Date"), whichever date is earlier. The Monthly Guarantee for any partial month during the Term shall be prorated on a per diem basis.

B. Percentage Compensation Fee. By the tenth (10th) day of the second and each succeeding month following the Rent Commencement Date, Concessionaire shall pay to the City the Percentage Compensation Fee for the previous month if and to the extent such Percentage Compensation Fee for such month exceeds the Monthly Guarantee for such month. At the same time, in a form acceptable to the City, Concessionaire shall furnish to the Airport's Finance Section and the Concessions Management Section a true and accurate verified revenue statement containing reasonably accurate detail of its Gross Revenues for the preceding month. The revenue statement shall be signed by Concessionaire's officer certifying that to the best knowledge of the officer, the Gross Revenue reported and the Compensation paid by Concessionaire was correct and properly calculated in accordance with the terms of this Agreement. The form acceptable to the City and presently in use is attached hereto as **Exhibit I**. At any time upon thirty (30) days advance written notice to Concessionaire, the City may require Concessionaire to submit its monthly revenue statements in electronic form, may change the timing of the submittal of the monthly revenue statements, or may otherwise modify the form of the monthly revenue statement. If a form is modified, Concessionaire agrees to begin using the new form the following month. In changing the required reporting format, the City may require and Concessionaire agrees to report Gross Revenues broken out by brand or concept, product or product line, or any other item listed on the Summary Page, **Exhibit E**, or otherwise approved by the City for sale in the Concession Space. The Parties agree that these changes may be made without the formality of amending this Agreement.

C. Marketing Assessment. Concessionaire shall calculate in its monthly revenue statement an amount equal to the percentage of monthly Gross Revenues stated on the Summary Page as Marketing Assessment. Concessionaire shall also pay to the City Concessionaire's share of the Joint Marketing Fund described in §13.01. The Marketing Assessment is payable to the City on the tenth (10th) day of the second month and each succeeding month following the Rent Commencement Date.

D. Additional Compensation. Without any deduction or set-off whatsoever, Concessionaire shall pay when due and as Additional Compensation all sums of money or charges required to be paid by Concessionaire under this Agreement, whether or not the same be designated "Additional Compensation." All Compensation, Percentage Compensation Fee, and any Additional Compensation payable in a given month shall be deemed to comprise a single rental obligation of Concessionaire to the City.

E. Concessionaire's Payment Obligations. Concessionaire covenants to pay all compensation and charges under this Agreement independent of any obligation of the City. No breach of this Agreement by the City shall relieve Concessionaire of its obligation and duty to pay all such compensation and charges when due.

5.04. TITLE TO CITY'S COMPENSATION

Immediately upon Concessionaire's receipt of monies from sales, services, or doing business under this Agreement, the percentages of said monies belonging to the City shall immediately vest in and become the property of the City. Concessionaire shall be responsible as trustee for said monies until the same are delivered to the City.

5.05. INTEREST ON PAST DUE AMOUNTS

Any payments not made to the City when due shall accrue interest at eighteen percent (18%) per annum ("Past Due Interest Rate"). Past Due Interest Rate commences on the fifth (5th) business day after the date such amount is past due and remains outstanding until paid to the City.

5.06. PLACE AND MANNER OF PAYMENTS

All sums payable to the City hereunder shall be made payable to "Airport Revenue Fund" and paid without notice at the following address:

Airport Revenue Fund
Denver International Airport
P.O. Box 492065
Denver, Colorado 80249-2065

Alternatively, by notice in writing to Concessionaire, the City may hereafter designate that payments be made at such other place or in such other manner. All sums shall be made in legal tender of the United States. Any checks given to the City shall be received by it subject to collection, and Concessionaire agrees to pay any charges, fees, costs, or expenses incurred by the City for such collection, including reasonable attorney's fees.

5.07. APPLICATION OF PAYMENTS

In the City's sole discretion, the City is entitled to accept, receive, cash, or deposit any payment made by Concessionaire for any reason or purpose in any amount whatsoever and apply such payment to any obligation of Concessionaire. Such payment or application shall not constitute payment of any amount owed, except that to which the City has applied the payment. If Concessionaire designates that any payment be applied to a specific portion of Concessionaire's financial obligations hereunder, any such designation by Concessionaire shall not be binding upon the City. Further, any endorsements or statements on a check or letter accompanying such payment for compensation or other charges shall not be deemed an accord and satisfaction or otherwise recognized for any purpose whatsoever. The acceptance of any such check, payment, or partial payment shall not prejudice the City's right to recover the balance of any compensation or other charges due from Concessionaire to the City. The City retains the right to pursue any other remedy provided in this Agreement, at law, or in equity.

5.08. BOOKS OF ACCOUNT AND AUDITING

A. Sales Records System. Concessionaire agrees to use a cash register and/or other point of sale system (including tabletop ordering devices and/or automated ordering systems) that is capable of producing duplicate sales slips or printouts on which each sale is identified, itemized, and recorded. Concessionaire shall maintain a system of bookkeeping satisfactory to the City and in conformity with generally accepted accounting principles. Such bookkeeping system shall be kept in a manner as to allow each location Concessionaire operates hereunder to be distinguished from Concessionaire's other locations or operations in the airport. In the presence of its customers, Concessionaire shall record at the time of sale all receipts from sales or other transactions whether for cash, credit, in a cash register, or in cash registers having a cumulative total. Such sales records systems shall be sealed in a manner approved by the City

and shall have such other features approved by the City. During normal business hours, the Manager's authorized representative shall have access to and the right to examine and copy such receipts at the Concession Space. The City may require Concessionaire to install electronic or digital point-of-sale equipment as part of its Concession Improvements or require Concessionaire's participation in any Airport point-of-sale system that may be established in the future. The cost of such requirement shall be reasonable in relation to the size of Concessionaire's operation and volume of business.

B. Evidence of Gross Revenues and Business Transacted. Concessionaire shall keep and preserve all recordkeeping and all other such evidence of Gross Revenues and business transacted ("Pertinent Original Sales Records") for a period of not less than three (3) years after Concessionaire delivers to the City true and complete records and accounts, or until sooner audited by the City. Pertinent Original Sales Records shall include each of the written statements required in §5.03 and §5.08A and shall include the following: (i) all sales slips, cash register tapes, sales books, bank books or duplicate deposit slips, tax returns, and adequate records for the period reported upon by Concessionaire's annual or monthly statements; (ii) statements showing inventories and receipts of items at the Concession Space, daily receipts from all sales, and other transactions on or from the Concession Space by Concessionaire and any other persons conducting any business transacted; (iii) books of account, bank statements, documents, records, papers, and files relating to the Gross Revenues and business transacted; (iv) cash register tapes, including daily bank deposits and tapes from temporary registers; (v) serially numbered sales slips; (vi) originals of all mail orders at and to the Concession Space; (vii) settlement report sheets of transactions with sub-tenants, concessionaires, and licensees; (viii) the original records showing that merchandise returned by customers was purchased at the Concession Space by such customers; (ix) memorandum receipts or other records of specialty retail items and merchandise taken out on approval; (x) such other sales records, if any, which would normally be examined by an independent accountant pursuant to accepted auditing standards in performing an audit of Concessionaire's sales; and (xi) the records specified in (iv) to (x) above of sub-tenants, assigns, concessionaires, or licensees. The City's acceptance of Concessionaire's payments of Percentage Compensation Fees shall not prejudice the City's right to examine Concessionaire's books and records. In order to verify the amount of Gross Revenues received by Concessionaire in and from the Concession Space, the City retains the right to examine Gross Revenues and inventories of merchandise at the Concession Space as provided in the paragraph below.

C. Annual Revenue Statements. Starting on the Rent Commencement Date, Concessionaire shall keep within the limits of the City and County of Denver true and complete pertinent sales records and accounts of all Gross Revenues and business transacted. If records are kept at Concessionaire's headquarters outside the limits of the City and County of Denver, Concessionaire shall have all records delivered to Denver when needed by the City, or Concessionaire will pay the City to have its auditors go to Concessionaire's headquarters to examine and access such records. Concessionaire shall furnish to the City a true and accurate annual statement of the total of all Gross Revenues and business transacted during the preceding calendar year (listing the authorized deductions or exclusions in computing the amount of such Gross Revenues and business transacted). Such annual statements are due to the City before February 28 of every calendar year in which business was transacted under this Agreement during the whole or part of any year of the Term. Such annual statements shall be prepared and certified to be true and correct by a corporate officer. Concessionaire's corporate officer may be the chief financial officer, executive officer, or another officer charged with such responsibility. Concessionaire's corporate officer who submits such annual statements must

certify that to the officer's best knowledge, the Gross Revenue reported and the Compensation paid by Concessionaire was correct and properly calculated in accordance with the terms of this Agreement. Such annual statements shall be submitted in a City approved form and style. Such annual statements shall include a complete itemized statement of the following from Concessionaire: (i) annual total Gross Revenues broken out by month and by location, as shown on the books and records of Concessionaire and detailing how any Percentage Compensation Fee during the period covered by the annual statement was computed; (ii) the total Compensation due under each category of sales reported on the monthly revenue statements; (iii) the total Compensation paid; and (iv) contain such details and breakdown of Gross Revenues as the City may reasonably require pursuant to §5.03B. The above requirements may be modified at any time if, in the sole and absolute discretion of the Manager, such modification is in the City's best interest.

D. City's Audit Rights. To verify compliance with this Agreement, the City acting through the City's Auditor ("Auditor"), the Manager, or the City's authorized representatives or agents shall have the right at any time to inspect, copy, examine, or audit all of Concessionaire's Pertinent Original Sales Records. Concessionaire agrees that it shall make all books and Pertinent Original Sales Records available to the City for examination at the Concession Space or within the Denver metropolitan area within fourteen (14) calendar days after Concessionaire receives the City's written request to audit Concessionaire's books and records. Further, Concessionaire agrees to pay the City's reasonable costs and expenses (not to exceed Two Thousand Dollars (\$2,000) per year) to annually perform or cause a test to be performed of Concessionaire's revenue accounting systems, records, and controls. If as a result of these tests, it is determined that a revenue audit of greater scope is necessary to ensure that revenues have been properly reported, then Concessionaire agrees to pay the City's reasonable cost and expense to perform or cause to be performed such a revenue audit, including payment in full and in advance of the City's reasonable cost and expense to travel to any location necessary to complete the audit. Additional audits may be conducted by the City or its agents at its own cost and expense. If an audit for any year determines that the Gross Revenues and business transacted were understated, as shown by Concessionaire's annual statement for such year, Concessionaire shall forthwith pay to the City the amount of the deficiency plus interest at the Past Due Interest Rate. If such audit reveals an understatement by three percent (3%), Concessionaire shall forthwith pay to the City the cost of such audit (including all third party fees and travel expenses) and the amount of any deficiency, plus interest at the Past Due Interest Rate from the date due. Concessionaire shall also have the obligation to furnish promptly to the City, whenever requested, financial statements reflecting Concessionaire's current financial condition. In addition, if such audit discloses an understatement of more than three percent (3%) at the City's option the City may terminate this Agreement upon issuing a five (5) day notice to Concessionaire if Concessionaire commits willful, grossly negligent, or fraudulent understatements of gross sales.

The Parties agree that any delay in furnishing such records will cause the City damages, which the Parties agree are liquidated in the amount of Three Hundred and Fifty Dollars (\$350) per day. Such liquidated damages begin to accrue fourteen (14) days following the date of the City's request and such requested records continue to be unavailable. The Parties agree that such liquidated damages shall be reasonable amounts and reasonable estimates of the loss anticipated to be suffered or incurred by the City. Liquidated damages will continue to accrue until the records become available or other arrangements satisfactory to the City to produce documents for examination are made. The City's right to perform such an audit shall expire three (3) years after Concessionaire's annual statement for that year has been delivered to the

City. Concessionaire expressly agrees that the Manager, the Auditor, and their authorized representatives may inspect any sales and/or use tax return or report, property tax returns, and accompanying schedules, petitions, and data, which Concessionaire may file with the City or State. Further, Concessionaire waives any claim of confidentiality that it may have in connection therewith for the sole purpose of allowing the City to use said records in the course of an audit.

5.09. REESTABLISHMENT OF RENTALS, FEES, AND CHARGES

At the Manager's sole discretion, the City through its Manager may from time to time reestablish the rentals, fees, and charges provided for herein at intervals of not more than five (5) years and be subject to the requirements of any outstanding bond ordinance pertaining to the Airport. The City agrees that such reestablished schedule of rentals, fees, and charges shall be reasonable in relation to the cost of providing, operating, and maintaining property, services, and facilities of the airport system. If the Manager proposes any changes in the schedule of rentals, fees, and charges, the City will give notice thereof to Concessionaire no less than ninety (90) days before the same is to become effective. Concessionaire may decline to pay Compensation at the new rate(s) if such proposed rentals, fees, and charges result in an increase of more than five percent (5%) in the dollar amount of Compensation paid by Concessionaire under §5.01 for the prior calendar year. In which case, Concessionaire shall promptly advise the Manager of its intention to cancel and terminate this Agreement at least sixty (60) days prior to the proposed effective date of such schedule of rentals, fees, and charges. Upon such notice of intent to cancel and terminate, Concessionaire shall surrender the Concession Space upon a date specified by the Manager within at least one hundred and twenty (120) days after Concessionaire advised the City. Should Concessionaire fail to give such notice of cancellation and termination, then Concessionaire shall be deemed to have accepted the new rate(s) of compensation as promulgated by the Manager. Failure by the City to reestablish the rentals, fees, and charges at a five (5) year interval date shall not waive the City's right to reestablish the rentals, fees, and charges at any time thereafter.

SECTION 6 – DESIGN, CONSTRUCTION, AND INSTALLATION OBLIGATIONS

6.01. ACCEPTANCE OF THE CONCESSION SPACE

Concessionaire acknowledges that it has had adequate opportunity to examine the Concession Space prior to entering into this Agreement and as of the Delivery Date, as documented by **Exhibit D**, Concessionaire accepts the Concession Space "AS IS, WHERE IS, AND WITH ALL FAULTS" and with absolutely no warranties as to condition or suitability for use being given by the City.

6.02. CONSTRUCTION OBLIGATIONS OF CONCESSIONAIRE

A. Time is of the Essence. Time is of the essence, and Concessionaire agrees that by no later than the Required Opening Date, Concessionaire will bear the sole cost and expense incurred to demolish and reconstruct the Concession Space completely, provide all work of whatsoever nature ("Concessionaire's Work"), obtain all necessary and required approvals and permissions, and Open for Business to the public. "Open(s) for Business" shall mean the date confirmed by the Parties and documented on **Exhibit D** after Concessionaire has completed the following: (i) delivered documentation satisfactory to the City that construction of the Concession Space has been completed; (ii) obtained written permission from the Manager or the Manager's

Authorized Representative to remove the construction wall surrounding the Concession Space; and (iii) commenced generating Gross Revenue from the Concession Space. In order to ensure prompt commencement and timely completion of construction and installation of the initial Improvements, Concessionaire agrees to submit its preliminary design and attend a pre-design meeting with the Airport's concessions management team. Concessionaire's designs must be submitted as soon as practicable but no later than the Preliminary Design Due Date. Thereafter, Concessionaire shall prepare a complete and detailed set of plans drawn by a registered architect, setting forth and describing Concessionaire's Work. Further, Concessionaire shall submit a proposed design, construction progress, and a completion schedule, in such detail as the City may reasonably require and in accordance with the design standards and criteria described herein.

B. NTP Documents Deadline. On or before the NTP Documents Deadline, as set forth on the Summary Page or as modified by **Exhibit D**, Concessionaire shall submit the NTP Documents listed in **Exhibit X** to the concessions management team for the City's review and approval. Concessionaire's Work shall be subject to approval in writing by the City, and Concessionaire acknowledges that Concessionaire's design plans will be reviewed by the Airport's contractor, also known as the Airport's Retail Architect Consultant. The fee for this review is estimated to range from Five Thousand Dollars (\$5,000) to Ten Thousand Dollars (\$10,000) depending on the amount of work required by the project. Concessionaire is obligated to pay this fee, and Concessionaire agrees to reimburse the City within thirty (30) business days after the City demands an amount not to exceed Ten Thousand Dollars (\$10,000) for the Airport's Retail Architect Consultant's actual costs for design review of Concessionaire's Work in connection with this initial build out of the Concession Space.

C. First-Class Standards of Design Required. Concessionaire shall begin the Work, shall diligently perform its design and construction obligations, and shall complete its work prior to the Required Opening Date. First-class standards of design and construction will be required in connection with all construction performed by Concessionaire, including construction and installation of all Improvements. Construction shall conform in all material respects with the criteria established at DIA for tenants and concessionaires for design, construction, installation, signage, and related matters, as such criteria may hereafter be amended. Further, construction shall conform with applicable statutes, ordinances, building codes, fire codes, State and federal Occupational Safety and Health Act safety requirements, and Airport Rules and Regulations. Additionally, construction shall conform with other general requirements of the City and the City's tenant construction permit requirements, including compliance with the requirements of **Exhibit X**, DIA Design Standards, DIA Development Guidelines, procurement of general liability and builder's risk insurance, and performance and payment bonds. Construction must also comply with worker's compensation requirements, the City's prevailing wage ordinance, Denver Revised Municipal Code ("D.R.M.C."), §20-76, the City's MBE/WBE participation requirements, D.R.M.C. Articles III and VII, and the Americans with Disabilities Act, 42 U.S.C. 12,000 et seq., and its regulations. The approval given by the City shall not constitute a representation or warranty as to such conformity; responsibility therefor shall at all times remain with Concessionaire. Approval by the City shall extend to and include consideration of architectural and aesthetic matters. The City expressly reserves the right to reject any designs submitted and to require Concessionaire resubmit designs and layout proposals until they meet the City's approval.

D. Construction Delays. To the extent completing the design review process, construction process, or opening for business is delayed by acts or omissions solely attributable

to the Airport, the amount of time caused by such delay shall be added to the Preliminary Design Due Date, NTP Documents Deadline, Rent Commencement Date, Required Opening Date, and Expiration Date, as documented on **Exhibit D**.

E. Liens and Encumbrances. Concessionaire will not create, permit to be created, or permit to remain any lien, encumbrance, or charge upon fixtures, equipment, or personal property located within the Concession Space. Within fifteen (15) calendar days after Concessionaire receives notice of the filing of such lien or encumbrance, Concessionaire shall discharge and cause any such lien to be released of record by payment, bond, or order of a court of competent jurisdiction.

F. Subsequent Alterations. Concessionaire agrees not to improve, change, alter, add to, remove or demolish the Concession Improvements, as defined herein. Further, Concessionaire agrees not to alter the Concession Improvements without the prior written consent of the City. If such consent is obtained, Concessionaire agrees to comply with the provisions of §6.02C and all conditions that the City in its sole discretion may require.

SECTION 7 - OPERATION AND USE

7.01. OPERATING A FIRST CLASS CONCESSION

Concessionaire agrees to conduct its business to accommodate the public and to operate the concession in the following manner:

A. First Class Concession. Concessionaire shall operate a first-class concession in a manner satisfactory to the Manager or the Manager's Authorized Representative. Service shall be prompt, clean, courteous, and efficient. Concessionaire shall not offer for sale any item (as defined herein) or engage in any activity not specifically provided for under the terms of this Agreement unless and until otherwise authorized in writing by the City.

B. Trade Name. Concessionaire represents that the trade name listed on the Summary Page is registered with the State of Colorado and will not be changed without the City's prior written approval.

C. Fully Stocked. Concessionaire shall supply sufficient items to fully stock its Concession Space. All items must be new, fresh and of top quality.

D. Pricing. Concessionaire shall charge only fair and reasonable prices, subject to the following conditions:

1. Concessionaire's proposed list of items to be offered for sale and prices to be charged for each item is attached hereto as **Exhibit E**. Concessionaire's items and pricing shall strictly conform to Concessionaire's Proposal unless and until otherwise authorized by the City. "Concessionaire's Proposal" shall mean the proposal as finally submitted by Concessionaire and accepted by the City, consisting of Concessionaire's plans for its design, proposed brand(s), if any, proposed items to be sold at the Airport, pricing plans, and Concessionaire's entire plan of operation. To obtain the City's authorization, At the City's request but no later than sixty-days prior to the date Concessionaire Opens for Business, Concessionaire shall update **Exhibit E** and submit its final list of items and pricing to the Concessions Administrative Manager for the City's approval. The updated list shall be certified by an officer of

Concessionaire under oath confirming that the listed items and prices comply with the requirements of this Agreement.

2. After final items and prices have been authorized by the City, **Exhibit E**, will be known as the Authorized Transactions List, which may be updated, replaced and superseded from time to time as changes are authorized by the City. Authorized Transactions Lists especially when used with the public (e.g. as menus, or merchandise or services lists), shall conform to all applicable laws and regulations respecting truth-in-advertising. Concessionaire shall not utilize false or deceptive merchandising terms or advertising. Prices are to be clear, legible, and conspicuously visible to customers prior to their making a purchase. Concessionaire shall not in any manner misrepresent to its customers the quality, grade, point of origin, size, portion, or weight of items sold. Changes to the authorized items and pricing may be made as provided below.

3. In order to ensure reasonable pricing for Airport customers, the Airport's current policy allows concessionaires to charge up to a maximum of 110% of the off-Airport or "street" price. Items with a pre-printed MSRP, such as newspapers, books, or periodicals, cannot be priced above the preprinted MSRP. Items with a pre-marked package price must be sold for the pre-marked package price. For branded concessions, the pricing comparison will be made by applying 110% against the same items or merchandise sold at the off-Airport branded locations as listed in **Exhibit F, Comparable Street Pricing**. For non-branded concessions, the pricing comparison will be made by employing 110% against the same list of items or merchandise sold at comparable locations, which shall be those three locations set forth in Concessionaire's Proposal as approved by the City and listed on **Exhibit F**. Taxes will be excluded in the comparison. If the Parties mutually agree, **Exhibit F** may be modified from time to time to reflect approved changes in Concessionaire's business concept or changes in the marketplace. If the Parties fail to mutually agree, however, the City will select the replacement location and revise **Exhibit F**.

4. Without exception, all price changes are subject to the City's approval. Concessionaire may change prices as long as changes comply with the City's pricing policy as described above and follow the procedure outlined herein. No less than two (2) weeks prior to any such price change, Concessionaire shall provide the City with written notice of the proposed price changes. Such price changes shall be certified by an officer under oath confirming that the new prices comply with the requirements of this Agreement. New prices shall take effect no sooner than the opening of business two weeks after the City receives Concessionaire's written notice, unless the City provides Concessionaire with a written objection to such change. If the City objects, the price change shall not be implemented until the City provides its prior written approval. Without exception, such price changes shall be subject to the City's approval. Concessionaire shall promptly discontinue any non-conforming price immediately after receiving written notice from the City.

5. Without exception, all changes to items the City authorizes Concessionaire to sell shall be subject to the City's approval. Concessionaire agrees to promptly discontinue any unapproved item immediately after receiving written notice from the City.

6. From time to time, the City at its sole discretion may require Concessionaire to offer for sale other items that the City determines are necessary to serve the traveling public and which will not require any additional equipment or increase operating costs, unless

Concessionaire establishes to the City's satisfaction that doing so would cause Concessionaire to be in default under its franchise or license Agreement, if any.

E. On-site Management. At all times, Concessionaire shall retain at the Concession Space a well-trained, experienced manager of a high quality businesses similar to the business of this concession. Such manager shall be fully authorized to represent and act for Concessionaire in the operation of the concession and to accept service of all notices provided for herein, provided such notice is simultaneously delivered to Concessionaire in accordance with §14.15. At times when this manager is not present at the Airport, Concessionaire shall assign or cause to be assigned a qualified subordinate to be in charge of the Concession Space, services, and facilities. Such qualified subordinate shall be available at the Concession Space to act for such manager.

F. Employees. During the required hours of operation, Concessionaire shall employ personnel in sufficient number and quality necessary to serve the public conveniently and efficiently. Such personnel shall be thoroughly qualified, familiar with the business, courteous, informative, and helpful to the public. All employees shall be clean, neat, professional, courteous, and of the highest character. All employees shall be attired appropriately and professionally in clean identifiable dress, in keeping with attire worn by personnel in similar first-class businesses in the Denver metropolitan area. All employees must at all times properly display the official Airport identification badge and identification as to their name and employer. Concessionaire's identification name tag shall clearly display Concessionaire's name. In the event that the City initiates one or more customer service programs for employees of tenants operating concessions at the Airport, the City reserves the right to require Concessionaire to fully participate (and cause its employees to participate) in such programs and shall immediately pay to the City its share of such costs upon invoice by the City.

G. Level of Service. All customers shall receive prompt, attentive, and courteous service. In the case of a restaurant or food and beverage concession, Concessionaire shall upon request issue one guest check per person. Processing of customer purchases, returns, and exchanges shall be prompt, and Concessionaire shall visibly display its return and exchange policy. Concessionaire shall properly itemize receipts, which shall reflect precisely the actual sale of goods and shall present individual prices, totals, and taxes, if any. In addition, receipts must also include Concessionaire's name or store name, store location (e.g., Concourse B), and a customer service telephone number.

H. Deliveries. Concessionaire shall make all deliveries of all items, money, coin, supplies, goods, and products, in such manner as specified by the Airport Rules and Regulations and at such times and locations as the Manager or the Manager's Authorized Representative may reasonably approve or require. Emergency deliveries may be made at other times subject to prior arrangements with the Manager or the Manager's Authorized Representative.

I. Licenses and Certificates. Concessionaire agrees to obtain at its own expense, keep current at all times, and comply with all applicable municipal, state, and federal licenses and certificates necessary or required by law for the conduct of Concessionaire's business at or upon the Concession Space, including where applicable those documents governing restaurants, food service establishments. Concessionaire shall comply with all applicable health, safety, and sanitary laws, regulations, and inspections concerning same.

Concessionaire shall also allow duly authorized representatives of governmental entities to access the Concession Space for inspection purposes.

J. Objectionable Practices. The Manager or the Manager's Authorized Representative shall have the right to make reasonable objections to the quality of any item sold, the character of the service rendered the public, and the appearance and condition of the Concession Space. To fully comply with the requirements of this Agreement, Concessionaire agrees to promptly discontinue or remedy any objectionable practice or condition pursuant to Section 10.

7.02. BRANDS

A. Concessionaire's Brand. If the City approves and accepts Concessionaire's Proposal to include a local, regional, or national brand, branded item, or branded concept that Concessionaire is authorized to use at Denver International Airport, such brand, term, or concept shall be listed or described on the Summary Page and will be referred to in this Agreement as "Concessionaire's Brand(s)." Concessionaire acknowledges and agrees that the use of brands is of critical importance in meeting the City's purpose for the concessions program at Denver International Airport. Therefore, Concessionaire's Brand is a material part of the consideration for this Agreement and may not be unilaterally discontinued or changed by Concessionaire. Any proposed new brand, term, concept, or change in use shall be submitted to the Manager or the Manager's Authorized Representative for written approval prior to implementing such new brand concept or change of use.

B. License or Franchise Agreement. If Concessionaire's Brand is not owned or controlled outright by Concessionaire, before execution of this Agreement by the City Concessionaire shall provide to the City an executed copy of any such separate license or franchise agreement or other documentation satisfactory to the City to confirm Concessionaire's authority to use Concessionaire's Brand at the Airport and to confirm that management and quality controls associated with the proposed brand are satisfactory to the City. The parties agree that Concessionaire may mark any such documents "confidential, commercial information" and may redact confidential financial information from the copy submitted to the City. Concessionaire must continuously abide by the terms of such license or franchise agreement and maintain the license or franchise agreement in good standing throughout the Term (or any extended term) of this Agreement. Concessionaire hereby represents that there is nothing contained in the license or franchise agreement, which would prevent it from fully performing this Agreement. If there is a conflict between this Agreement and any such franchise or license agreement, Concessionaire agrees the terms and conditions of this Agreement shall control. If Concessionaire fails to provide such documentation within thirty (30) days after execution of this Agreement, the City may terminate this Agreement by written notice to Concessionaire, in which event the Agreement shall terminate on the date stated in said notice.

7.03. CREDIT CARDS AND DEBIT CARDS

Concessionaire shall accept and display its acceptance of gift certificates, airline vouchers, traveler's checks, debit cards, and nationally recognized credit cards, including American Express, MasterCard, VISA, and Discover. No minimum credit card or debit card purchase amount or charge for credit card purchases is allowed.

7.04. HOURS OF OPERATION

Concessionaire agrees to keep its concession facilities open for business to the public continuously during the hours described on the Summary Page unless otherwise authorized beforehand in writing by the City. Concessionaire shall use its best efforts to respond to any weather emergency and/or flight diversion situations that might require certain locations to open or remain open before or beyond these minimum hours. In unusual circumstances (e.g., diversions, delayed flights, weather), the City reserves the right to require Concessionaire to open its Concession Space before or remain open beyond the designated operating hours.

7.05. CARE OF AREA

Concessionaire agrees that it will keep the Concession Space in a neat, clean, safe, sanitary, and orderly condition at all times. Concessionaire further agrees that at all times it will keep such area free of all paper, rubbish, spills, and debris. At its own expense, Concessionaire shall collect and deposit all trash and refuse at frequent intervals at collection station locations specified by the City. Accumulation of boxes, cartons, barrels, or other similar items shall not be permitted in any public area in the Airport. At its own expense, Concessionaire shall be responsible for janitorial services for the Concession Space. Concessionaire shall pay and require its contractor and all of its subcontractors to pay Prevailing Wages for work in connection with the operation of the Concession Space that costs Two Thousand Dollars (\$2,000) or more, such as paying for a doorkeeper, caretaker, cleaner, window washer, porter, keeper, janitor, or similar custodial or janitorial work.

7.06. SALES AND DIGNIFIED USE

Concessionaire shall ensure that all personnel refrain from any loud, boisterous, offensive, or inappropriate conduct and that personnel treat all customers professionally, equally, and courteously, including addressing customers without regard to race, creed, color, national origin, ethnicity, age, disability, gender, or sexual orientation. Concessionaire shall use reasonable efforts to employ an adequate number of bilingual personnel to serve English and non-English-speaking customers as market demand may warrant. Concessionaire's employees and agents shall not engage in "high pressure" sales tactics (such as "hawking" or "haggling") or unfair or deceptive trade practices in the operation of the concession. Concessionaire is strictly prohibited from engaging in any activities outside the Concession Space within the Airport for the recruitment or solicitation of business. Unless the City issues prior written approval, Concessionaire shall not place, install, maintain, or use any racks, stands, or other display of merchandise, trade fixtures, or furnishings in or upon any areas located outside the Concession Space, regardless of whether such areas are adjacent to the Concession Space. Concessionaire shall not conduct a public or private auction, fire sale, going out of business, bankruptcy sale, or similar types of sales in or from the Concession Space without the City's prior written approval unless otherwise approved by the Manager or the Manager's Authorized Representative. The Concession Space shall be used only in a dignified and ethical manner, consistent with the general high standards of other first-class concessions operating at the Airport.

7.07. VENDING MACHINES

No amusement machines, vending machines, or any other machines operated by coins, paper currency, tokens, or credit/debit cards shall be installed or maintained in or upon the

Concession Space unless expressly permitted under this Agreement. This prohibition includes sales from vending machines of items like cigarettes, candy, maps, coffee, soft drinks, newspapers, stamps, insurance policies, and telephones. The dispensation of cash, money orders, and checks is likewise prohibited. This prohibition also applies to the operation of mechanical or electronic game devices, electronic video games, and entertainment devices.

7.08. MAINTENANCE OF A FIRST-CLASS CONCESSION SPACE

Concessionaire shall bear all costs of operating Concessionaire's business on the Concession Space. The City shall have no obligation, liability, or responsibility whatsoever to maintain, repair, or replace any portion of the Concession Space. Concessionaire further agrees to promptly pay when due all bills, debts, and obligations incurred by it in connection with its operations hereunder. Concessionaire shall at all times and at Concessionaire's sole expense maintain the Concession Space in a first-class condition.

A. Maintenance. As conditions and the City may require, Concessionaire shall at its sole cost and expense keep and maintain in good order, condition, appearance, and repair (including any such replacement and restoration as is required for that purpose) the Concession Space and every part thereof, including all Improvements therein, any appurtenances thereto wherever located, and all equipment in accordance with manufacturer's recommendations. If an inspection by the City determines that any maintenance is necessary, Concessionaire shall promptly comply with and shall pay all costs of any recommendation to redecorate, repair, repaint, or refinish the Improvements or repair or replace fixtures, furnishings, and equipment that become worn, chipped, dented, gouged, or otherwise damaged.

B. Repairs and Remodel. All repairs, replacements, or remodeling to the Concession Space done by or on behalf of Concessionaire shall be completed with due diligence and in a good and workmanlike fashion. Such repairs and remodeling shall be of first-class quality in both materials and workmanship, shall be equal to or better than the original in materials and workmanship, and shall be in compliance with the requirements of **Exhibit X**. In addition, all work should comply with all conditions imposed by the City and all applicable permits, authorizations, laws, statutes, ordinances, orders, rules, and regulations of governmental authorities having jurisdiction over or otherwise affecting the Concession Space and all appurtenances thereto. After notice and an opportunity to cure as set forth in Section 10, if Concessionaire refuses or neglects to commence and complete repairs promptly and adequately, the City may without liability make and complete said repairs on behalf of and for Concessionaire at the City's standard rates or by a contractor hired by the City. Upon demand, Concessionaire agrees to reimburse and pay the cost thereof to the City plus an administrative fee of twenty percent (20%). The City shall be the sole judge of the quality of Concessionaire's maintenance obligation.

C. Repair Payment. Costs and expenses with respect to such maintenance, repair, and replacement shall be paid promptly when due. The maintenance, repair, and replacement shall be accomplished free of liens by mechanics and materialmen.

D. Prior Approval. Except for repairs caused by an emergency or repairs (not including modifications or changes) that cost less than Fifteen Thousand Dollars (\$15,000), all repairs must have the prior written approval of the City. Concessionaire must notify the City of all repairs as soon as possible. Following such notice, the City may inspect the repair work and require alterations if the repair is not satisfactory to the City. The City shall be the sole judge of

the quality of the repairs, replacements, or remodeling performed. Except for the above-described repairs costing less than Fifteen Thousand Dollars (\$15,000), prior to beginning any repair, replacement, or remodeling work, Concessionaire shall notify the City and secure written City approval before beginning any repairs, replacements, or other work it intends to do, including the timeline to finish such work. For all repairs costing Two Thousand Dollars (\$2,000) or more, Concessionaire shall require its contractor and all of its subcontractors to pay Prevailing Wages to every worker, laborer, or mechanic employed by them. Prevailing Wages include fringe benefits or their cash equivalent for the same class and kind of work in the City and County of Denver, as determined by the Career Service Board and as required by the provisions of D.R.M.C. §20-76.

E. Emergency Repair Notification. In the event of an emergency repair situation, Concessionaire must notify the City of the repair situation as soon as possible. Following such notice, the City may inspect the repair work and require alterations if the repair is not satisfactory to the City. Notwithstanding any provision to the contrary, all repairs requiring shutdown of any Airport system require prior written approval of the Manager or the Manager's Authorized Representative. If an emergency repair is completed by the City, the City shall invoice any or all Concessionaires who may have contributed to the cause of the incident.

7.09. RENOVATION OF CONCESSION SPACE

A. Renovation. At its sole cost and expense, Concessionaire shall renovate, refurbish, and refresh the Concession Space by the Renovation Completion Date(s) shown on the Summary Pages. The date, amount, and scope of renovation(s) may be determined by mutual agreement of the Parties. For all renovations, full and complete specifications for all work and improvements along with a statement of the time required to complete such renovations shall be submitted to and approved in writing by the City before renovation and/or construction work commences. Electronic copies of plans for all renovations shall be given to Airport Engineering for review and written approval prior to commencement of construction. Concessionaire shall begin and diligently perform its renovation obligations and shall complete its work prior to the expiration of the mutually agreed upon time for completion of Concessionaire's renovation obligations. The provisions of §6.02B shall apply.

B. Renovation Details. The scope of renovation(s) shall be set by the City if no mutual agreement concerning the date, amount, and scope of renovation(s) is reached by the Parties on or before eighteen (18) months prior to the Renovation Completion Date stated on the Summary Page. Concessionaire shall complete such renovations at a time no later than the Renovation Completion Date(s) specified on the Summary Page and in an amount no less than the Renovation Minimum investment amount stated on the Summary Page. In addition, the following shall apply:

1. Concessionaire shall provide design plans and specifications of proposed renovation(s) of the Concession Space that meet the Renovation Minimum Investment for the City's approval no later than one (1) year prior to the Renovation Completion Date or such lesser time as is agreed to in writing by the City.

2. An amount consisting of no less than fifty percent (50%) of the Renovation Minimum Investment shall be allocated to refreshing the Concession Space by aesthetic renovation, defined as replacement of all parts of the Concessions Spaces visible to, used by, and/or provided for enhanced service to the public, including signage, flooring, paint, finishes,

fixtures, furnishings, lighting, ceiling, and millwork. Life safety and health code upgrades are not considered aesthetic renovation. Each renovation of the Concession Space required by this Agreement shall be completed and documented as provided below.

3. The Renovation Minimum Investment shall not include financial costs, interest, inventory, pre-opening expansion, or intracompany charges related to construction, but it may include architectural and engineering charges not exceeding fifteen percent (15%) of the total Renovation Minimum Investment. As soon as practicable after construction of the renovation, but in no event later than ninety (90) days after substantial completion of the renovation, Concessionaire shall file with the City a statement certified by its architect setting forth the total renovation costs with appropriate detail itemizing the elements of decorations, furnishings, and fixtures. At the City's request, Concessionaire shall make available to the City receipted invoices for labor and materials covering all construction and trade fixtures, including furniture, fixtures, and equipment. Upon receipt by the City of Concessionaire's statement of renovation costs, the City shall review the statement and in the event the total cost of Concessionaire's renovation is less than the Minimum Renovation Investment, Concessionaire will pay the difference between such total cost and the Minimum Renovation Investment for renovating the Concession Space to the City within thirty (30) days after written demand from the City to Concessionaire.

7.10. TITLE TO IMPROVEMENTS

Concessionaire agrees that all Concession Improvements or any other improvements to the Concession Space, including approved changes and renovations that are affixed to the realty, shall become the property of the City upon their completion and acceptance by the City.

7.11. SURRENDER OF CONCESSION SPACE

Upon the expiration of this Agreement, earlier termination of this Agreement, or on the date specified in any demand for possession by the City after any uncured default by Concessionaire, Concessionaire covenants and agrees to surrender possession of the Concession Space and all Improvements to the City in broom clean condition, in a good state of repair, and in the same code-compliant condition, except for ordinary wear and tear, as the Concession Space was delivered on the date Concessionaire Opened for Business to the public. Concessionaire shall surrender all keys for the Concession Space to the City at the place then fixed for the payment of compensation. Concessionaire shall inform the City of all, if any, combinations on locks, safes, and vaults in the Concession Space. Ordinary wear and tear shall not include deterioration that could have been prevented by proper maintenance practice or by Concessionaire performing all of Concessionaire's obligations under this Agreement. Concessionaire covenants and agrees to cooperate with the City's termination procedures.

7.12. REMOVAL OF CONCESSIONAIRE'S EQUIPMENT

During the last thirty (30) days of the Term, Concessionaire shall remove all Concessionaire's Equipment, as defined in **Exhibit X**; all signage, trade fixtures, and trade dress not permanently attached or affixed; and to the extent required or allowed by the City by written notice, any other installations, alterations, or improvements before surrendering the Concession Space. Concessionaire shall repair in good and workmanlike fashion any damage to the Concession Space caused by such removal. If Concessionaire fails to remove any of Concessionaire's Equipment within two (2) days after the termination of this Agreement or of Concessionaire's

right to possession, the City, at Concessionaire's sole cost and expense, shall be entitled (but not obligated) to remove and store Concessionaire's Equipment. The City shall not be responsible for the value, preservation, or safekeeping of Concessionaire's Equipment. Upon demand, Concessionaire shall pay or the City will extract from the surety any expenses and/or storage charges incurred for the removal or storage of any of Concessionaire's Equipment. In addition, if Concessionaire fails to remove Concessionaire's equipment from the Concession Space within five (5) days after written notice, the City may at its option deem all or any part of Concessionaire's Equipment to be abandoned and title to Concessionaire's Equipment shall be deemed to be immediately vested in the City. Anything notwithstanding to the contrary, Concessionaire shall not remove any improvements, alterations, partitions, lighting, or flooring if not directed or allowed by the City. Concessionaire's obligation to observe or perform this covenant shall survive the expiration or other termination of the Term.

7.13. DAMAGE CAUSED TO OTHER PROPERTY

Concessionaire shall be responsible for any damage caused by Concessionaire to the Airport, any City property or operations, or the property of any other concessionaire, person, or entity, either by act, omission, or as a result of the operations of Concessionaire. Subject to §12.04, and upon demand, Concessionaire agrees to reimburse the City, concessionaire, or other such person or entity for any such damage. If the same type of damage is caused by Concessionaire more than once in a twelve (12) month period, such as a water leakage, electrical service interruption, or other damage, Concessionaire shall submit a Remediation Plan, as set forth in Section 10; however, if the Parties cannot reach agreement on the Remediation Plan then the City shall repair the damage at the City's standard rates or the City may hire a contractor, and upon demand, Concessionaire agrees to reimburse and pay the cost thereof to the City plus an administrative fee of twenty percent (20%).

7.14. COMPLIANCE WITH ALL LAWS AND REGULATIONS

A. Illegal Use. Concessionaire agrees not to use or permit the Concession Space to be used for any purpose prohibited by the laws of the United States or the State of Colorado or the ordinances or Charter of the City and County of Denver. Concessionaire further agrees that it will use the Concession Space in accordance with all applicable federal, state, and local laws and will observe and comply with all general rules, regulations, standards, and guidelines adopted by the City or the Manager for the management, operation, and control of the Airport, either promulgated by the City on its own initiative or in compliance with regulations or actions of the Federal Aviation Administration or other authorized federal agency, as they may be amended from time to time ("Airport Rules and Regulations"). Concessionaire's failure to keep and observe said rules and regulations shall constitute a breach of the terms of this Agreement in the manner as if the same were contained herein as covenants. Concessionaire agrees to comply with Federal, State and Local Disadvantaged Business programs as more fully set forth in **Exhibit B, Disadvantaged Business Enterprise Participation; Exhibit G, ACDBE Commitment Form**; and **Exhibit X**. Concessionaire further agrees to submit any report(s) or information that the City is required by law or regulation to obtain from Concessionaire or which the Manager may request relating to Concessionaire's operations.

B. Americans with Disabilities Act. Without limiting the foregoing, Concessionaire shall determine and assess the requirements to design, construct, and operate and shall at all times maintain the Concession Space in accordance with and in compliance with the requirements of the Americans with Disabilities Act ("ADA"), 42 USC §12,000 et seq., including the ADA

Accessibility Guidelines and all federal regulations adopted pursuant to the ADA. In the event that compliance cannot be achieved, Concessionaire shall proceed formally to the federal agency having jurisdiction for a waiver of compliance. In order to comply with any requirements of the ADA or any other laws, codes, or regulations, the City may demand that Concessionaire reimburse the City for costs incurred by the City to make any additions, alterations, or improvements to any part of the Airport to effect such compliance if Concessionaire uses, occupies, or makes any alterations, additions, or improvements to the Concession Space in a manner that makes the Concession Space non-compliant.

7.15. COMPLIANCE WITH ENVIRONMENTAL REQUIREMENTS

Concessionaire is responsible for compliance and shall require its contractors to comply with all federal, state, and local environmental rules, regulations, and requirements. This includes compliance with DIA Rule and Regulation 180, and the attached *Exhibit J*. Concessionaire shall obtain all necessary federal, state, local, and airport permits and comply with all permit requirements. Any hazardous materials not normally used in Concessionaire's operations hereunder are barred from the Concession Space. Concessionaire shall identify to the City all hazardous materials to be used at the Concession Space.

7.16. WASTE OR IMPAIRMENT OF VALUE

Concessionaire agrees that nothing shall be done or kept in the Concession Space that might impair the value of the City's property or that would constitute waste.

7.17. HAZARDOUS USE

Concessionaire agrees that nothing that might be unsafe or hazardous to any person or property shall be done or kept in the Concession Space. Additionally, Concessionaire agrees to make no improvements, changes, alterations, additions, maintenance, or repairs made in the Concession Space that might be unsafe or hazardous to any person or property. Further, Concessionaire shall not do or permit to be done any act or thing that will invalidate, suspend, or increase the rate of any fire insurance policy required under this Agreement, or carried by the City, covering the Concession Space or the buildings in which the Concession Space is located. Further, Concessionaire shall not do or permit to be done any act or thing that in the opinion of the Manager or the Manager's Authorized Representative may constitute a hazardous condition that will increase the risks normally attendant upon the operations contemplated under this Agreement. If Concessionaire fails to comply with the provisions of this Section for any reason after receiving written notice from the City and any fire insurance rate on the Concession Space or on the buildings in which the same is located becomes higher than it normally would be at any time, then Concessionaire shall pay the City, on demand, that part of all fire insurance premiums paid by the City which have been charged because of such violation or failure of Concessionaire. Nothing herein shall preclude Concessionaire from bringing, keeping, or using such materials, supplies, equipment, and machinery as are appropriate or customary in the ordinary course of its business or from carrying on the normal operations contemplated herein.

7.18. STRUCTURAL, ELECTRICAL, OR SYSTEM OVERLOADING

Concessionaire agrees that nothing shall be done or kept on the Concession Space and no improvements, changes, alterations, additions, maintenance, or repairs made that might impair the structural soundness of the building; result in an overload of utility, plumbing, or HVAC

systems serving the Terminal and/or Concourses; or interfere with electric, electronic, or other equipment at the Airport. In the event of violations hereof, Concessionaire agrees immediately to remedy the violation at Concessionaire's expense.

7.19. NOISE, ODORS, VIBRATIONS, AND ANNOYANCES

Concessionaire shall conduct its operations in an orderly and proper manner so as not to commit any nuisance or annoy, disturb, or be offensive to others at the Airport and shall take all reasonable measures, using the latest known and practicable devices and means, to eliminate any unusual, nauseous, or objectionable noise, gases, vapors, odors, and vibrations and to maintain the lowest possible sound level in its operations. No pets are allowed (except as may be permitted or required by law with respect to persons with disabilities) and no lighting device, radio, television, microphone, loudspeaker, telephone, megaphone, or other similar device that the City determines to be annoying or offensive shall be used in or about the Concession Space unless prior authorization is given by the City.

7.20. ACCESSIBILITY

Concessionaire shall not do or permit anything to be done that might interfere with the effectiveness or accessibility of utility, heating, ventilating, or air conditioning systems or portions thereof on the Concession Space or elsewhere on the Airport. Concessionaire will not do nor will Concessionaire permit to be done anything that may interfere with free access and passage in the Concession Space or the public areas adjacent thereto, or hinder police, firefighters, or other emergency personnel in the discharge of their duties. Further, Concessionaire shall not do or permit to be done anything that might interfere with the effectiveness or accessibility of elevators or escalators in or adjacent to the Concession Space, including lines, pipes, wires, conduits, and equipment connected with or appurtenant thereto. Concessionaire shall not place any additional lock of any kind upon any window or interior or exterior door in the Concession Space, or make any change in any existing door or window lock or the mechanism thereof, unless a key therefor is maintained on the Concession Space were furnished to or otherwise procured by Concessionaire. If any keys furnished to Concessionaire by the City are lost, Concessionaire shall pay the City, on demand, the cost for replacement thereof.

SECTION 8 – UTILITIES AND SERVICES

8.01. UTILITIES

Most concession areas in the Terminal and Concourses have services of adequate capacity to supply reasonable amounts of hot or chilled water, gas, electricity, potable water, fire protection, sanitary waste, grease waste, and storm sewer capacity to serve the concession areas. Concessionaire shall verify capacity of all systems in the Concession Space and shall be responsible for all utility system upgrades that are necessary for their concession build out. As of the date of actual possession, Concessionaire shall be responsible for the payment of all utilities that are required for operations in the Concession Space.

At its option, the City may bill Concessionaire its pro-rata share of certain utilities consumed or estimated to be consumed at the Concession Space. In such case, the City will charge a rate no higher than that which would allow the City to recover the cost of providing the service, including but not be limited to standard rates, fees, and charges established by the Airport. Any

bills by the City for such costs shall be due within thirty (30) days and shall accrue interest at the Past Due Interest Rate if not paid when due.

8.02. HEATING AND AIR CONDITIONING (HVAC)

Concessionaire shall at its expense furnish, install, and maintain any ductwork and other connections within or leading into its Concession Space that are required in order to connect and complete the HVAC from the Airport's central system for the Concession Space. The City shall at its expense furnish normal and reasonable quantities of central air from the central HVAC system to the Concession Space and all necessary power and electricity for such central air circulation. Subject to conditions beyond its control, the City shall maintain under normal conditions a temperature adequate for comfortable occupancy according to the season, provided that Concessionaire properly maintains the ductwork and other connections within or leading into its Concession Space and complies with the recommendations of the City's engineer regarding reasonable occupancy and use of the Concession Space.

8.03. WATER SERVICE

Concessionaire shall at its expense furnish, install, and maintain a water meter for the Concession Space, if required by the City, at a location and of a type specified by the City and shall pay all costs for water used within the Concession Space. Concessionaire shall be responsible for all water hook-ups of its equipment. The City shall furnish water from the central water source in reasonable quantities; provided that Concessionaire complies with all water conservation programs in effect or as adopted.

8.04. ELECTRICITY AND NATURAL GAS

Concessionaire shall at its expense furnish, install, and maintain an electric meter and a gas meter for the Concession Space, if required by the City, at a location and of a type specified by the City. Concessionaire shall pay all costs for electricity and gas used within the Concession Space. Concessionaire shall at its expense furnish, install, and maintain all power circuits and connections required for equipment and mechanical systems used in the Concession Space. Upon request by Concessionaire and at its cost and expense, the City or its designee, will bring a premises wiring system to the Concession Space to handle electronic information such as telephone and telecommunications equipment. Concessionaire shall be responsible for any extension of the wiring and connection of any terminals and devices in accordance with City requirements, and Concessionaire shall pay for telephone service to the Concession Space.

8.05. LIGHTING

Concessionaire shall at its expense furnish, install, and maintain all lighting fixtures and wiring for general illumination of the Concession Space. Wattage requirements and levels of illumination shall be subject to the City's approval.

8.06. WINDOW WASHING AND STRUCTURAL MAINTENANCE

The City shall, at its expense, provide exterior window washing and maintain all structural parts of the Terminal and Concourses, at scheduled intervals as deemed necessary by the City,

including exterior glass, walls, and roof but specifically excluding Concession Improvements made by Concessionaire or conditions caused by Concessionaire's operations.

8.07. COMMON USE SERVICES

The Manager may establish common use services at the Airport, including trash and refuse removal, deliveries, industrial waste handling, recycling, and security guards. The Manager reserves the right to establish charges for common use services based upon documented actual costs. Trash, sewer, and deliveries will be common use services that Concessionaire may be required to use and pay its pro rata actual share; however, other common use services may be utilized at Concessionaire's option. Concessionaire agrees to pay the charges for those common use services that are utilized by Concessionaire.

8.08. INTERRUPTION OF SERVICES

Concessionaire agrees that the City shall not be liable for Concessionaire's loss for failure to supply any utility services. The City reserves the right to temporarily discontinue utility services at such time as may be necessary by reason of accident, unavailability of employees, repairs, alterations, or improvements or whenever by reason of strikes, lockouts, riots, acts of God, or any other happenings beyond the control of the City and causes the City to be unable to furnish such utility services. The City shall not be liable for damages to persons or property for any such discontinuance due to causes beyond the control of the City, nor shall such discontinuance in any way be construed as cause for abatement of Compensation or operate to release Concessionaire from any of its obligations hereunder, except as otherwise provided in Section 12 entitled "Damage, Destruction, or Loss."

SECTION 9 – INDEMNITY AND INSURANCE AND GUARANTEES

9.01. INDEMNITY

Concessionaire hereby agrees to release, indemnify, and save harmless the City, its officers, agents, officials, and employees from and against any loss of or damage to property, or injuries to or death of any person or persons, including property and employees or agents of the City. Concessionaire shall defend, indemnify, and save harmless the City, its officers, agents, officials, and employees from all claims, damages, suits, costs, expense, liability, actions, penalties or proceedings of any kind or nature whatsoever, including worker's compensation claims, of or by anyone whomsoever, in any way resulting from, or arising out of, directly or indirectly, its operations in connection herewith, its construction of the Concession Space, or its use or occupancy of any portion of the Airport. This includes acts and omissions of officers, employees, officials, representatives, suppliers, invitees, contractors, subcontractors, and agents of Concessionaire, provided that Concessionaire need not release, indemnify, or save harmless the City, its officers, officials, agents, and employees from damages resulting from the sole negligence of the City's officers, officials, agents, and employees. The minimum insurance requirements prescribed herein shall not be deemed to limit or define the obligations of Concessionaire hereunder.

9.02. INSURANCE

A. Required Insurance. Concessionaire agrees to secure at its own expense and to keep in force at all times during the Term (or any extended term) hereof, insurance against

claims for injury to persons or damage to property that may arise from or in connection with the performance of obligations under this Agreement by Concessionaire, its agents, representatives, or employees. The types and amounts of insurance coverage Concessionaire must procure are specified in the Certificate of Insurance for Aviation, attached hereto as **Exhibit C**. Insurance requirements set forth on **Exhibit C** do not limit in any way the indemnity covenants contained in this Agreement or the amount or scope of liability of Concessionaire under this Agreement. The amounts listed indicate only the minimum amounts of insurance coverage that the City is willing to accept to help insure full performance of all terms and conditions of this Agreement. Concessionaire specifically agrees to comply with each condition, requirement, or specification set forth in **Exhibit C** during all periods when the required coverage is in effect. Insurance must be maintained without any lapse in coverage during the entire Term (or any extended term) of this Agreement. Insurance canceled without the City's consent or failure by Concessionaire to provide evidence of renewal within forty-eight (48) hours after written notice by the City is a material breach and shall be deemed an immediate event of default under this Agreement. If at any time any of the insurance policies shall be or become unsatisfactory to the City as to form or substance, or if any of the carriers issuing such policies shall be or become unsatisfactory to the City, Concessionaire shall promptly obtain a new and satisfactory replacement policy and give the City an updated certificate of insurance that complies with the new insurance requirements of the City.

B. Mutual Waiver of Subrogation. Concessionaire and the City waive any right of action that they and/or their insurance carriers might have against each other (including their respective employees, officers, commissioners, or agents) or against other tenants of the Airport for any loss, cost, damage, or expense (collectively "Loss") to the extent that such loss or damage is covered by any property insurance policy or policies maintained or required to be maintained pursuant to this Agreement and to the extent that such proceeds (which proceeds are free and clear of any interest of third parties) are received by the party claiming the Loss. Concessionaire also waives any right of action it and/or its insurance carrier might have against the City (including its respective employees, officers, commissioners, or agents) for any Loss described in Section 12, whether or not such Loss is insured. If any of Concessionaire's applicable insurance policies do not allow the insured to waive the insurer's rights of subrogation prior to a Loss, Concessionaire shall cause it to be endorsed with a waiver of subrogation that allows the waivers of subrogation required by this §9.02.

C. Certificates Required. All certificates required by this Agreement (including renewal certificates) shall be sent directly to Denver International Airport, Concessions Management Section, Airport Office Building, Room 9870, 8500 Pena Boulevard, Denver, Colorado 80249. The City's contract control number for this Agreement shall be noted on each certificate of insurance. Certificates evidencing the existence of the policies, in such form as the City may require, shall be delivered to the City prior to the Target Possession Date. Upon written request by the City, Concessionaire agrees to furnish to the City at any time thereafter during the Term (or any extended term) of this Agreement the original or a certified copy of said policy or policies.

D. Concessionaire's Risk. The City in no way warrants that the minimum limits contained herein are sufficient to protect Concessionaire from liabilities that might arise out of the performance of the terms and conditions of this Agreement by Concessionaire, its agents, representatives, or employees. Concessionaire shall assess its own risks and as it deems appropriate and/or prudent, maintain higher limits and/or broader coverage. Concessionaire is not relieved of any liability or other obligations assumed or pursuant to the Agreement by reason

of its failure to obtain or maintain insurance in sufficient amounts, duration, or types. In no event shall the City be liable for any: (i) business interruption or other consequential damages sustained by Concessionaire; (ii) damage, theft, or destruction of Concessionaire's inventory, Improvements, or property of any kind; or (iii) damage, theft, or destruction of an automobile, whether or not insured.

E. Governmental Immunity. The Parties hereto understand and agree that the City and County of Denver, its officers, officials, and employees are relying on and do not waive or intend to waive by any provisions of this Agreement, monetary limitations, or any other rights, immunities, and protections provided by the Colorado Governmental Immunity Act, §§ 24-10-101 to 120, C.R.S., or otherwise available to the City and County of Denver, its officers, officials, and employees.

9.03. PERFORMANCE SURETY

A. Standard Surety Requirements. On or before the Delivery Date as documented on *Exhibit D*, Concessionaire shall deliver to the City and maintain in effect at all times throughout the Term, including a period of six (6) months after expiration of the Term (or any extended term) or earlier termination of this Agreement, an irrevocable letter of credit or such other acceptable surety (e.g., cash or bonds) as first approved in writing by the City, in an amount equal to six (6) months of the initial Monthly Guarantees ("Performance Surety"). Such an irrevocable letter of credit or other acceptable surety requirement may be increased by the Manager, shall be payable without condition to the City, and shall be issued by a surety with qualifications acceptable to and approved by the Manager. All irrevocable letters of credit shall be in a form and issued by a bank acceptable to the City and shall be subject to claim in full or in part by the City upon presentation of the letter of credit and a sight draft as provided herein. The Performance Surety shall guarantee to the City full and faithful performance of (i) all of the terms and provisions of this Agreement by Concessionaire, as said Agreement may be amended, supplemented, or extended, and (ii) all obligations and duties of Concessionaire under all general rules and regulations adopted by the City or the Manager for the management, operation, and control of the Airport as amended or supplemented. The Performance Surety may be issued for a one (1) year period, provided however, that evidence of renewal or replacement of the surety must be submitted annually by Concessionaire to the City at least sixty (60) days prior to the expiration date of the instrument. The surety shall contain language that the Performance Surety company shall notify the City in writing within forty-five (45) days of a determination that the surety is to be terminated or is not going to be renewed.

B. Performance Surety Subject to Increase by City. Notwithstanding any provision herein to the contrary, if at any time during the Term (or any extended term), the Manager deems the amount of the Performance Surety insufficient to properly protect the City from loss hereunder because Concessionaire is or has been in arrears with respect to such monetary obligations or because Concessionaire has, in the opinion of the Manager, violated other terms of this Agreement, Concessionaire agrees that after receiving notice and an opportunity to cure, it will increase the surety to an amount required by the Manager, provided however, the percentage increase in the amount of surety shall not exceed the annual percentage increase that has occurred with respect to Concessionaire's Compensation in effect under this Agreement.

C. Replenishment Obligation. If the City chooses to draw upon the Performance Surety as provided in §11.02, it shall be the obligation of Concessionaire to replenish the Performance

Surety to the originally contracted level within thirty (30) days of such draw down by the City. Failure to maintain or replenish the Performance Surety shall constitute a material breach of this Agreement.

D. Alternative Surety Program. Alternatively, upon Concessionaire's request, the Manager may in his or her sole discretion permit Concessionaire temporarily to provide an Alternative Surety as defined below.

1. Payment of the Alternative Surety is due in advance upon notification by the Airport of the amount due.

2. The "Alternative Surety" shall be a fee ("Base Fee") paid to the City of two percent (2%) of the annual Rent due by Concessionaire in the prior calendar year or if a full year is unavailable, two percent (2%) of the annualized Rent due, as calculated by the City. If no Rent payment history is available or if the Manager in his/her sole discretion determines the existing Rent payment history is insufficient, the Base Fee shall be two percent (2%) of twelve times the Monthly Guarantee then in effect.

3. Payment of the Base Fee as surety in no way reduces or offsets the Compensation or amounts due from Concessionaire to the Airport under this Agreement.

4. The Alternative Surety will apply for one (1) year after all of the following have occurred ("Alternative Surety Period"): (i) Full execution of this Agreement, (ii) issuance of notice of Base Fee and Additional Fee (described below) under the terms of this subsection, and (iii) receipt of payment due of Base Fee and Additional Fee (described below) under the terms of this §9.03. At the end of the Alternative Surety Period, the Standard Surety requirements of this §9.03 shall automatically apply for the remainder of the Term (or any extended term) of the Concession Agreement, unless the Alternative Surety is extended by the Manager.

5. The Alternative Surety may be extended by the Manager of Aviation, in the Manager's sole discretion, for additional one (1) year periods through the Term (or any extended term) of this Agreement.

6. The Base Fee shall be recalculated at the end of each Alternative Surety Period. The Base Fee may be adjusted by the Manager to account for the following:

- a. For every late Rent notice issued to Concessionaire, the Manager may in his/her discretion increase the Base Fee by one-half percent (0.5%) of the annual Rent due in the prior calendar year ("Additional Fee"); however, if no late Rent notices were issued to Concessionaire in the prior calendar year then the Manager may reduce any existing Additional Fee by one-half percent (0.5%) of annual Rent due.
- b. A factor consisting of some or all of the following: the Airport's general risk due to local or national changes to the aviation industry, the Airport's cost for administering the alternative surety, and the market cost of Letters of Credit, Revenue Surety instruments, or similar instruments.
- c. In no event shall the recalculated Base Fee be less than two percent (2%) of the greater of the following: the annual Rent due by Concessionaire in the

prior calendar year; or if a full year is unavailable, the annualized Rent due, as calculated by the City; or if no Rent payment history is available or the Manager in his/her sole discretion determines the existing Rent payment history is insufficient, two percent (2%) of twelve times the Monthly Guarantee then in effect.

- d. Concessionaire shall be notified of any recalculated Base Fee and Additional Fee in writing by the City at the time the Alternative Surety is extended.
- e. If the Alternative Surety is extended and recalculated by the Manager but Concessionaire no longer desires to comply with the Alternate Surety Program, Concessionaire may instead submit the Standard Surety required in this §9.03.

7. The Alternative Surety may be terminated at any time at the discretion of the Manager or Concessionaire upon thirty (30) days written notice to the other Party. Upon such termination, the Standard Surety requirements of this §9.03 of this Agreement shall apply. Any unamortized portion of the Base Fee and Additional Fee for the Alternative Surety shall be refunded to Concessionaire upon Concessionaire's compliance with the Standard Surety requirements of this §9.03.

8. Alternative Surety fee payments do not reduce any liability or obligation of Concessionaire to the City. Payment of such fees merely substitute for the Standard Surety Requirements stated in §9.03A.

9.04. UNCONDITIONAL GUARANTEE [RESERVED]

9.05. NO PERSONAL LIABILITY

Except for any obligations concerning this Agreement given by any person pursuant to any written guarantee agreement, no director, officer, or employee of the either Party shall be held personally liable under this Agreement because of its good faith execution or attempted execution.

9.06. TAXES, LICENSES, LIENS, AND FEES.

A. Prompt Payment Required. Concessionaire shall promptly pay all taxes, assessments, excises, license fees, and permit fees of whatever character applicable to its operations hereunder that may be levied, assessed, or charged upon the personal property or possessory interest, used, owned, or occupied by Concessionaire, or upon the rights of Concessionaire to occupy the Concession Space.

B. Concessionaire Maintains Responsibility for Liens. Concessionaire also shall not permit, create, or suffer to be created or to remain, any mechanic's, materialman's, or any other lien to become attached or be foreclosed upon the Concession Space or improvements thereto, or any part or parcel thereof, by reason of any construction, services, work, or labor performed or materials furnished by any mechanic or materialman. If any such lien shall at any time be filed, Concessionaire may contest the same in good faith. Notwithstanding such contest, Concessionaire shall, within fifteen (15) calendar days after the filing thereof, cause such lien to be released of record by payment, bond, or order of a court of competent jurisdiction. In the

event Concessionaire fails to clear the record of any such lien within the aforesaid period, the City may remove said lien by paying the full amount thereof, by bonding, or in any other manner the City deems appropriate, without investigating the validity thereof, and irrespective of the fact that Concessionaire may contest the propriety or the amount thereof. Thereafter Concessionaire shall pay the City the amount paid by the City in connection with the discharge of said lien. Upon demand, Concessionaire agrees to reimburse the City as provided in §11.02 Nothing contained in this Agreement shall be construed as consent on the part of the City to subject the Concession Space to any lien or liability.

C. Agreement to Furnish Receipts. Concessionaire agrees to furnish to the Manager, upon request, duplicate receipts or other satisfactory evidence showing Concessionaire's prompt payment of its Social Security, unemployment insurance, worker's compensation insurance, all required licenses, and all taxes.

SECTION 10 - FAILURE TO OPERATE AND MAINTAIN A FIRST-CLASS CONCESSION

10.01. MANAGER'S OBJECTIONS

According to all the terms and conditions established in Section 7 and this Section 10, the Manager or the Manager's Authorized Representative shall have the right to make reasonable objections to Concessionaire's failure to create a first-class concession at the Airport and failure to maintain, operate, and use its business in a manner satisfactory to the Manager or the Manager's Authorized Representative ("Operational Deficiency"). The City agrees to complete the process described in this Section 10 as a condition precedent to treating an Operational Deficiency as an event of default and exercising the remedies described in Section 11.

10.02. REMEDIATION OF OPERATIONAL DEFICIENCIES

A. Notice. Should Concessionaire have an Operational Deficiency, the City shall send Concessionaire a notice to correct the problem without declaring it an event of default ("First Notice"). The First Notice will contain a correction period of not less than ten (10) days (the "Correction Period") within which to correct the problem. Any notice to Concessionaire required or permitted under this Section 10 shall be in writing and delivered to Concessionaire's ownership, management, or its on-site management or staff via letter, email, or by some other written form as may be adopted from time to time by the City. In addition to the foregoing, a copy of any Second Notice shall also be delivered to Concessionaire at the notice address for Concessionaire specified in this Agreement.

B. Remediation. Unless the problem can be cured and is cured within the Correction Period, prior to the expiration of the Correction Period, Concessionaire shall submit to the City a written plan for the correction of the problem ("Remediation Plan"). The Remediation Plan shall include a detailed description of the steps Concessionaire will take to correct the problem and the deadlines for completion of such steps. If a Remediation Plan is approved by the City in its reasonable discretion, and for so long as Concessionaire complies with the approved plan, any Liquidated Damages shall not be imposed. Any additions or modifications to the Remediation Plan must be pre-approved in writing by the City. If Concessionaire fails to: (i) correct a problem prior to the expiration of the Correction Period, (ii) timely submit a Remediation Plan, (iii) receive the City's approval of a Remediation Plan within ten (10) days of timely submitting the same, or (iv) comply with any portion of the approved Remediation Plan, the City shall have the right to assess the Liquidated Damages described below.

C. Liquidated Damages. Assuming that the Operational Deficiencies are ultimately corrected, Concessionaire's delay in complying with its obligations under this Agreement is reasonably anticipated to result in inconvenience to the public, adversely affect the overall business of the Airport, and detrimentally reduce the amount of Compensation paid to the City. Additionally, City resources will be expended in dealing with Operational Deficiencies. Accordingly, if Concessionaire fails to: (i) correct a problem prior to the expiration of the Correction Period, (ii) timely submit a Remediation Plan, (iii) correct a problem prior to the expiration of the Correction Period stated in a City approved Remediation Plan, or (iv) comply with any portion of the approved Remediation Plan, the City may provide Concessionaire with a notice of liquidated damages ("Second Notice"). Such liquidated damages shall begin to accrue immediately, unless a later date is indicated in the Second Notice. The Parties agree that damages sustained by the City for Operational Deficiencies could be significant but would be difficult to determine and to track if the problem is ultimately corrected. The Parties agree that under the circumstances a reasonable estimate of damages for Operational Deficiencies that is ultimately corrected is: One Hundred Dollars (\$100) per day per infraction for each whole or partial day until the problem is corrected. Concessionaire and the City agree that the liquidated damages set forth are reasonable amounts and reasonable estimates of the loss anticipated to be suffered or incurred by the City but only if the problems are ultimately corrected. Liquidated damage amounts shall be due and payable upon demand by the City.

D. Event of Default. If Concessionaire fails to correct the problem within thirty (30) days after receiving the Second Notice, in the Manager's sole and absolute discretion the City shall have the right to treat the Operational Deficiency as an event of default by sending Concessionaire a formal notice of default under §11.01 concerning the Operational Deficiency. The liquidated damages related to such default shall stop accruing as of the expiration of the thirty (30) day cure period provided in §11.01, and the City shall thereafter have the right to seek any other remedy available to the City under Section 11.

E. Invalidity. If any or all of the provisions of this Section 10 are found to be unenforceable, any affected Operational Deficiency shall then be immediately covered by Section 11, and the City shall have all of the remedies provided in Section 11.

SECTION 11 –DEFAULT AND REMEDIES

11.01. DEFAULT

Except as limited by Section 10, Concessionaire shall be in default under this Agreement if:

A. Failure to Pay Compensation. Concessionaire fails to pay to the City within five (5) days of when due any installments of the Compensation and/or any other charge or payment herein reserved, included, or agreed to be treated or collected as rental and/or any other charge, expense, or cost herein agreed to be paid by Concessionaire, and such failure to pay is not cured within ten (10) days after written notice by the City of Concessionaire's failure to pay. The acceptance of any sums of money from Concessionaire after the expiration of such five (5) or ten (10) day period as above provided shall be taken to be a payment on account by Concessionaire and shall not constitute a waiver by the City of any rights, nor shall it reinstate this Agreement or cure a default on the part of Concessionaire; or

B. Cross-Default. Concessionaire is in default under any other agreement with the City for concession space at the Airport; or

C. Performance Surety. If Concessionaire cancels the Performance Surety without City consent and does not reestablish it promptly after written notice by the City; or

D. Bankruptcy/Insolvency. For purposes of this Agreement and to the extent permitted by the United States Bankruptcy Code, Concessionaire shall be deemed to be insolvent in the following instances: (i) making an assignment by Concessionaire for the general benefit of creditors; (ii) the filing by Concessionaire of a voluntary petition in bankruptcy; (iii) dissolution; (iv) the appointment of a receiver, trustee, or liquidator of any or substantially all of the properties of Concessionaire and the receiver, trustee, or liquidator is not discharged within forty- five (45) days; (v) the filing of an involuntary petition of bankruptcy and failure of Concessionaire to secure a dismissal of the petition within sixty (60) days after filing; or (vi) if proceedings for reorganization or for composition with creditors under any state or Federal law be instituted by or against Concessionaire, and attachment of, or the levying of execution on this Concessionaire's interest, or the sale of the real or personal property of Concessionaire by any Sheriff, Marshall, or Constable and failure of Concessionaire to prevent the sale, or to secure discharge of the attachment or release of the levy of execution within forty-five (45) days; and (vii) any seizure, execution, attachment, or similar process is issued against Concessionaire, any assignee, sub concessionaire, licensee, or occupant of the Concession Space, or any Guarantor; or any encumbrancer takes any action or proceeding whereby any of the improvements, fixtures, furniture, equipment, or inventory in or relating to the Concession Space or any portion thereof or the interest of Concessionaire therein or in this Agreement or any business conducted in or from the Concession Space shall be taken or attempted to be taken; or

E. Unapproved Transfer. Concessionaire purports to make an assignment or transfers its interest under this Agreement by reason of death, operation of law, assignment, sublease, sale in bulk of any of its assets, or otherwise to any other person or business entity other than in compliance with the provisions of this Agreement; or

F. Failure to Submit NTP Documents. Concessionaire fails to submit NTP documents within fourteen (14) days after the NTP Documents Deadline. Concessionaire shall cure the default within thirty (30) days after receipt of a written default notice from the City. If the cure cannot be completed within the thirty (30) day period and Concessionaire begins performing whatever may be required to correct its failure, Concessionaire can cure the default by continuing such performance as soon as practical in good faith, with all due diligence, and without interruption, except for causes beyond its control; or

G. Failure to Open for Business. Concessionaire fails to Open for Business within fourteen (14) days after the Required Opening Date. Concessionaire shall cure the default within thirty (30) days after receipt of a written default notice from the City. If the cure cannot be completed within the thirty (30) day period and Concessionaire begins performing whatever may be required to correct its failure, Concessionaire can cure the default by continuing such performance as soon as practical in good faith, with all due diligence, and without interruption, except for causes beyond its control; or

H. Abandonment. Concessionaire abandons, deserts, vacates, or ceases operations for five (5) consecutive business days, unless undergoing repairs or renovations have first been approved by the City; or

I. Failure to Maintain Insurance. Concessionaire fails to maintain any type of insurance or level of insurance coverage required hereunder (and in the event Concessionaire has failed to remedy such failure within ten (10) days after notice thereof from the City, the City may effect such coverage and recover the cost thereof immediately from the Performance Surety or from Concessionaire); or

J. Liens Against City Property. Concessionaire suffers any lien or attachment to be filed against the Concession Space, the Airport, or the City's property because of any act or omission of Concessionaire, and such lien or attachment is not discharged or contested by Concessionaire in good faith by proper legal proceedings within fifteen (15) days after receipt of notice thereof by Concessionaire; or

K. Illegal Use. Concessionaire uses or gives its permission to any person to use for any illegal purpose any portion of the Airport made available to Concessionaire for its use under this Agreement; or

L. License or Franchise Agreements. Concessionaire's license or franchise agreement related to Concessionaire's Brand or trade name Concessionaire is authorized to operate at the Airport is terminated, expires, or is amended so that compliance with the amended provisions will cause Concessionaire to be in breach of its obligations under this Agreement; or

M. Default in Other Covenants. Concessionaire fails to keep, perform, and observe any other promise, covenant, or agreement set forth in this Agreement, other than the payment of Compensation or additional compensation as described above, and such failure or violation is not cured within thirty (30) days after written notice by the City describing the nature of the failure or violation. This cure provision shall be complied with if (i) the violation is of such a nature that it cannot be completely cured within the thirty (30) day period, (ii) Concessionaire begins to perform whatever may be required to correct its failure to perform its obligation or to correct the violation within such thirty (30) day period, and (iii) Concessionaire proceeds in good faith and continues such performance with all due diligence and without interruption, except for causes beyond its control, to effect the cure as soon as practical.

11.02. REMEDIES

A. City may elect to perform. If Concessionaire fails to perform any of Concessionaire's obligations under this Agreement, the City, without waiving any of its remedies pursuant to this Agreement, may but shall not be obligated to perform the same for the account of and at the expense of Concessionaire without notice in a case of emergency, and in any other cases, after such failure continues after the expiration of thirty (30) days from the date the City gives Concessionaire written notice of the failure specifying the details. The City may elect to perform work at the City's standard rates or have work performed by a contractor hired by the City. Upon demand, Concessionaire agrees to reimburse the City and Concessionaire shall pay the cost thereof to the City plus an administrative fee of twenty percent (20%). The City shall not be liable to Concessionaire for any claim for damages resulting from such remedial action by the City.

B. Remedies upon Default. If Concessionaire defaults in any of the covenants, terms, and conditions herein, the City may exercise any one or more of the following remedies:

1. The City may allow this Agreement to continue in full force and effect and to enforce all of City's rights and remedies hereunder, including the right to collect Compensation as it becomes due together with Past Due Interest and draw upon the Performance Surety in any amount necessary to satisfy the damages sustained or reasonably expected to be sustained by the City; or

2. The City may terminate this Agreement and repossess the Concession Space, upon giving thirty (30) days written notice to Concessionaire of its intention to terminate, at the end of which time all the rights of Concessionaire under this Agreement shall terminate, unless the default which shall have been stated in such notice is by its nature curable and shall have been cured within such thirty (30) days. The notice shall be final and shall at the option of the City (a) terminate all of the rights hereunder of Concessionaire, and the City may upon the date specified in such notice, reenter and repossess the Concession Space with or without process of law, without liability for trespass, and using such force as may be necessary, expel Concessionaire, remove therefrom all property of both, and store the same at the expense of Concessionaire, or (b) elect to proceed under subparagraph 3 below.

If the City elects to terminate this Agreement, Concessionaire shall be liable to the City for all amounts owing at the time of termination, including Compensation due plus interest thereon at the Past Due Interest Rate together with any other amount to fully compensate the City for all loss of compensation, damages, costs, and attorney's fees caused by Concessionaire's failure to perform its obligations hereunder, or which in the ordinary course would likely result therefrom.

3. The City may elect to reenter and take possession of the Concession Space and expel Concessionaire and those claiming through or under Concessionaire and remove the effects of as may be necessary with or without process of law, without liability for trespass, using such force as may be necessary, and without prejudice to any remedies for damages or breach. No such reentry shall be construed as an election on the City's part to terminate this Agreement, unless a written notice of termination specifically so states; however, the City reserves the right to terminate the Agreement at any time after reentry. Following reentry, the City may relet the Concession Space or any portion thereof for the account of Concessionaire on such terms and conditions as the City may choose. The City may make alterations, repairs, or improvements to the Concession Space as the City deems appropriate to accomplish the reletting. The City shall not be responsible for any failure to relet the Concession Space or any failure to collect compensation due for such reletting.

If the City elects to reenter and take possession of the Concession Space, Concessionaire shall be liable to City for all costs of reletting, including attorney's fees, repairs, and improvements. Notwithstanding re-entry by the City, Concessionaire shall continue to be liable for all amounts due as Compensation under this Agreement on the dates specified plus interest thereon at the Past Due Interest Rate together with such amounts as would be payable, including costs and attorney's fees caused by Concessionaire's failure to perform its obligations hereunder or which in the ordinary course would likely result therefrom. Upon expiration of the Term or any earlier termination of the Agreement by the City, the City, having credited to Concessionaire's account any amounts recovered through reletting, shall refund without interest any amount that exceeds the compensation, damages, and costs payable by Concessionaire under this Agreement.

11.03. REMEDIES CUMULATIVE

A. Remedies Cumulative and Concurrent. All of the remedies given to the City in this Agreement and all rights and remedies given to the City at law or in equity shall be cumulative, concurrent, and not exclusive.

B. Recovery of Space. No termination of this Agreement or the taking or recovering of the Concession Space shall deprive the City of any of its remedies or actions against Concessionaire for Compensation due at the time or which, under the terms hereof, would in the future become due. Nor shall the bringing of any action for unpaid Compensation or breach of covenant or resort to any other remedy herein provided for the recovery of unpaid Compensation be construed as a waiver of the right to obtain possession of the Concession Space.

11.04. WAIVER

No failure of City to insist upon the strict performance of a term, covenant or agreement contained in this Agreement, no failure by City to exercise any right or remedy under this Agreement, and no acceptance of full or partial payment during the continuance of any default by Concessionaire shall constitute a waiver of any such term, covenant or agreement or a waiver of any such right or remedy or a waiver of any default by Concessionaire.

11.05. ADMINISTRATIVE HEARING

Disputes arising out of this Agreement shall be resolved by administrative hearing before the Manager following the procedures outlined in D.R.M.C. §5-17, provided that the City shall retain its right to obtain an order of eviction in accordance with applicable state law. No cause of action shall be brought against the City until there has been full compliance with the terms of this paragraph. The Manager's determination resulting from said administrative hearing shall be final, subject only to Concessionaire's right to appeal the determination under Colorado Rules of Civil Procedure, Rule 106.

SECTION 12 – DAMAGE, DESTRUCTION, OR LOSS

12.01. DAMAGE TO OR DESTRUCTION OF CONCESSION SPACE

If the Concession Space, the Concourse in which the Concession Space is located, or any portion thereof is destroyed or damaged by fire or otherwise to an extent that renders it unusable, the City may rebuild or repair any portions of the building structure destroyed or damaged, and if the cause was beyond the control of Concessionaire, Concessionaire's obligation to pay the Compensation hereunder shall abate as to such damaged or destroyed portions during the time they are unusable. If the City elects not to proceed with the rebuilding or repair of the building structure, it shall give notice of its intent within ninety (90) days after the destruction or damage. At its option, Concessionaire may then terminate this Agreement effective as of the date of such event.

12.02. COOPERATION IN THE EVENT OF LOSS.

If the City elects to rebuild, Concessionaire must replace all Concession Improvements at its sole cost and in accordance with the Required Minimum Investment in 2012 dollars. Such replacements must be in accordance with the performance standards set forth in **Exhibit X**.

The City and Concessionaire shall cooperate with each other in the collection of any insurance proceeds that may be payable in the event of any loss or damage.

12.03. LOSS OR DAMAGE TO PROPERTY.

The City shall not be liable for the following: (i) any damage to property of Concessionaire or others located on the Concession Space or in the Airport; (ii) the loss of or damage to any property of Concessionaire or of others by theft or otherwise; (iii) any injury or damage to persons or property resulting from fire, explosion, falling plaster, steam, gas, electricity, water, rain, or snow; (iv) leaks from any part of the Concession Space or Airport; from the pipes, appliances, or plumbing works; from the roof, street, subsurface, or from any other place; or from dampness or by any other cause of whatsoever nature; (v) any such damage caused by other Concessionaires, persons in the Concession Space, occupants of adjacent property, of the Airport, or of the public; (vi) damages caused by operations in construction of any private, public, or quasi-public work; (vii) any latent defect in the Concession Space or in the building of which they form a part; and (viii) all property of Concessionaire kept or stored on the Concession Space at the risk of Concessionaire only. Further, Concessionaire shall hold the City harmless from and hereby waives any claims arising out of damage to the same or damage to Concessionaire's business, including subrogation claims by Concessionaire's insurance carrier. Concessionaire shall give immediate telephone notice to the City in case of fire, casualty, or accidents in the Concession Space or in the building of which the Concession Space is a part, of defects therein, or in any fixtures or equipment. Concessionaire shall promptly thereafter confirm such notice in writing.

12.04. MUTUAL WAIVER/INSURANCE COVERAGE.

The City and Concessionaire each waive any and every claim for recovery from the other for any loss of or damage to the Concession Space or to the contents thereof that is covered by valid and collectible fire and extended insurance policies, to the extent that such loss or damage is recoverable under such insurance policies. Since this mutual waiver will preclude the assignment of any such claim by subrogation or otherwise to an insurance company or any other person, Concessionaire agrees to give to each insurance company, which has issued or may issue to Concessionaire's policies of fire and extended coverage insurance, written notice of the terms of this mutual waiver. If necessary, Concessionaire agrees to have such insurance policies properly endorsed to prevent the invalidation of the insurance coverage by reason of this waiver.

SECTION 13 – PROMOTIONAL PROGRAM

13.01. JOINT MARKETING FUND

The City shall provide or cause to be provided a central marketing and promotional fund, which in the City's sole judgment will serve to promote overall service, retail, and food and beverage concessions at the Airport. The fund shall be known as the "Joint Marketing Fund." The City shall not be obligated to expend more for promotions and advertising than is actually collected from Concessionaires. Any promotional services and personnel so provided shall be under the exclusive control and supervision of the City. The City reserves the right at any time to terminate the Joint Marketing Fund and thereafter, continue to provide marketing and promotional services until the balances remaining in the Fund are exhausted.

13.02. PREMIUM VALUE CONCESSIONS PROGRAM

A. PVC Program. The Department of Aviation has created a Premium Value Concessions Program ("PVC Program") pursuant to Rule 45 of the Airport Rules and Regulations (the "PVC Rules") to reward certain categories of concessionaires that maintain the high performance standards defined in the PVC Rules.

B. Participation Required. Concessionaire acknowledges that it is required by this Agreement and the PVC Rules to participate as a single location in the PVC Program. The major and minor categories and square footage relating to Concessionaire's participation in the PVC Program are listed on the Summary Page. Concessionaire agrees that upon written notice from the Manager, Concessionaire shall contribute Concessionaire's prorated share of the cost of PVC Program, which will be calculated in accordance with the methodology set forth in the PVC Rules. Concessionaire's contribution shall be payable to the City in advance without setoff, deduction, prior notice, or abatement. Concessionaire's contribution commences on the first day of every month, following the City's notification and continuing until the Joint Marketing Fund generates One Million Dollars (\$1,000,000) in annual revenue.

C. City's Cost Obligations. The City shall not be obligated to expend more for the PVC Program than is actually collected from Concessionaires. All services related to the PVC Program and all personnel engaged by the City to provide services related to the PVC Program, including the services of a Third Party Administrator as that term is defined in the PVC Rules, shall be under the exclusive control and supervision of the City.

D. Termination of Program. Under certain circumstances described in the PVC Rules, the Manager has the sole and absolute discretion to terminate the PVC Program upon a thirty (30) day written notice to Concessionaire.

E. Agreement Supersedes in Event of Conflict. In the event of a conflict between any provision of the PVC Rules and this Agreement, the provisions of this Agreement, including the Summary Page, exhibits, and appendices appended hereto, shall govern.

SECTION 14 – MISCELLANEOUS PROVISIONS

14.01. ADVERTISING AND PUBLIC DISPLAYS

Concessionaire may not advertise in the Airport, except with an advertising company that has contracted with the City's advertising contractor to sell advertising at the Airport. Permission will not be granted to Concessionaire for any other advertising at the Airport. Concessionaire shall not use nor permit the Concession Space to be used as a medium for third party paid advertising, including sponsorships or any advertising material, sign, fixture, or equipment, whether paid for in-kind, by cash, or by credit.

14.02. AGREEMENT BINDING UPON SUCCESSORS

Subject to the provisions of §14.12 entitled "Assignment and Sublease," this Agreement shall be binding upon and shall inure to the heirs, personal representatives, successors, and assigns of the City and Concessionaire where permitted by this Agreement.

14.03. AGREEMENT MADE IN COLORADO; VENUE

This Agreement shall be deemed to have been made in and shall be construed in accordance with the laws of the State of Colorado, as well as the Charter and Ordinances of the City and County of Denver. The Parties agree that venue for any action arising from this Agreement shall be in the District Court in and for the City and County of Denver. The laws of the State of Colorado shall govern the validity, performance, and enforcement of this Agreement.

14.04. AGREEMENT SUBORDINATE TO-AGREEMENTS WITH THE UNITED STATES

This Agreement is subject and subordinate to the terms, reservations, restrictions, and conditions of any existing or future agreements between the City and the United States, when the execution of such agreements has been or may be required as a condition precedent to the transfer of federal rights or property to the City for Airport purposes and the expenditure of federal funds for the extension, expansion, or development of the Airport or airport system. The provisions of the attached Appendices 1 and 2 are incorporated herein by reference and in the event that the FAA or its successors requires modifications or changes to this Agreement, as a condition precedent to the granting of funds for the improvement of the Airport, or otherwise. Concessionaire agrees to consent to such amendments, modifications, revisions, supplements, or deletions of any of the terms, conditions, or requirements of this Agreement as may be reasonably required to satisfy the FAA requirements.

14.05. RIGHT TO DEVELOP AIRPORT

Concessionaire agrees that the City reserves the right to further develop or improve the Airport, all landing areas, and taxiways as the City may see fit, regardless of the desires or views of Concessionaire and without any interference or hindrances from Concessionaire.

14.06. MASTER PLAN

Concessionaire agrees that no liability shall attach to the City, its officers, agents, and employees by reason of any efforts or action toward implementation of any present or future master layout plan for the Airport. Concessionaire waives any right to claim damages or other consideration arising therefrom.

14.07. AGREEMENT SUBJECT TO AVIATION PRIORITY

Concessionaire's right to use the Concession Space for the purposes set forth in this Agreement shall be secondary and subordinate to the operation of the Airport. Concessionaire acknowledges that because of the location of the Concession Space at the Airport, noise, vibrations, fumes, debris, and other interference with the Permitted Use will be caused by Airport operations. Concessionaire hereby waives all rights or remedies against the City arising out of any noise, vibration, fumes, debris, and/or interference that is caused by the operation of the Airport. The City specifically reserves for itself and for the public a right of flight for the passage of aircraft in the airspace above the surface of the Airport. Additionally, the City reserves for itself the right to cause in said airspace such noise, vibration, fumes, debris, and other interference as may be inherent in the present and future operation of aircraft.

14.08. BOND ORDINANCES

This Agreement is in all respects subject and subordinate to any City bond ordinances applicable to the Airport, airport system, and to any other bond ordinances, which should amend, supplement, or replace such bond ordinances. The Parties to this Agreement acknowledge and agree that all property subject to this Agreement that was financed by the net proceeds of tax-exempt bonds is owned by the City. Concessionaire agrees not to take any action that would impair or omit to take any action required to confirm the treatment of such property as owned by the City for purposes of §142(b) of the Internal Revenue Code of 1986, as amended. In particular, Concessionaire agrees to make and hereby makes an irrevocable election (binding on itself and all successors in interest under this Agreement) not to claim depreciation or an investment credit with respect to any property subject to this Agreement that was financed by the net proceeds of tax-exempt bonds. Concessionaire shall execute such forms and take such other action as the City may request in order to implement such election.

14.09. EARLY TERMINATION

The City reserves the option, in its sole discretion, to terminate this Concession Agreement in the event the Airport has an operational need for or desires to construct upon or through the Concession Space ("Early Termination"). The City shall provide Concessionaire with no less than thirty (30) days prior written notice of any such termination and the effective date of such termination ("Early Termination Date"). Concessionaire shall surrender possession of the Concession Space to the City in the manner required by this Agreement on or before the Early Termination Date. Notwithstanding any provision to the contrary, except for the City's obligation to pay the Early Termination Compensation described below, this Agreement shall be terminated as of the Early Termination Date. The City shall be obligated to pay Concessionaire the appraised value of Concessionaire's business for the Term of the Agreement as set forth in a detailed written appraisal prepared by an American Society of Appraisers ("ASA") certified Accredited Senior Appraiser in accordance with the ASA's business valuation standard of Fair Market Value, as defined in BVS-I General Requirements for Developing a Business Valuation ("Early Termination Compensation"). The Accredited Senior Appraiser will be selected by mutual agreement of the Parties or by the City in good faith if agreement is not achieved within thirty (30) days from the date of the notice of Early Termination. The cost of the appraisal will be borne by the City. Except to the extent considered by the appraiser in determining the value of Concessionaire's business, the City shall not be liable for nor subject to any claim for attorney's fees, costs, or expenses; interest; interruption of business; lost profits; indirect damages; or other similar claims. Concessionaire shall not be entitled to Early Termination Compensation if this Agreement is terminated because of a default event or for any reason not associated with this Early Termination provision. Concessionaire shall have no further claim of any kind whatsoever against the City by reason of such Early Termination.

14.10. FORCE MAJEURE

Neither Party hereto shall be liable to the other for any failure, delay, or interruption in the performance of any of the terms, covenants, or conditions of this Agreement due to causes beyond the control of that Party, including without limitation strikes, boycotts, labor disputes, embargoes, shortages of materials, acts of God, acts of the public enemy, acts of superior governmental authority, weather conditions, floods, riots, rebellion, sabotage, or any other circumstance for which such Party is not responsible or which is not in its power to control. A lack of funds, however, will never be deemed beyond a Party's power to control, and in no event

shall this paragraph be construed so as to allow Concessionaire to reduce or abate its obligation to pay the Monthly Guarantee, Percentage Compensation Fee, or any other compensation due herein.

14.11. INCONVENIENCES DURING CONSTRUCTION

Concessionaire recognizes that from time to time during the Term of this Agreement, it may be necessary for the City to commence or complete extensive programs of construction, expansion, relocation, maintenance, and repair in order that the Airport and its facilities may be maintained, improved, completed, and operated in accordance with any present or future master layout plan. Further, Concessionaire acknowledges that such construction, expansion, relocation, maintenance, and repair may inconvenience Concessionaire in its operation at the Airport. Concessionaire agrees that no liability shall attach to the City, its officers, agents, employees, contractors, subcontractors, and representatives by way of such inconveniences. Concessionaire agrees to waive any right to claim damages or other consideration therefrom.

14.12. ASSIGNMENT AND SUBLEASE

Concessionaire shall not assign, transfer, sublease, pledge, hypothecate, surrender, or otherwise encumber (collectively "Transfer"), or dispose of this Agreement or any interest created by this Agreement or any interest in any portion of the same without the City's consent. Concessionaire shall not grant any license or concession hereunder, or permit any other person or persons, company, or corporation to occupy the Concession Space without first obtaining the written consent of the Manager who has the sole and absolute discretion to grant or deny consent. Any attempt by Concessionaire to in any way directly or indirectly Transfer all or part of its interest in this Agreement (including any attempt to transfer the ownership of the equity or voting interest in the stock if Concessionaire is a corporate entity or the ownership interest in such other entity or control of Concessionaire or Concessionaire's operations through sale, exchange, merger, consolidation, or other such Transfer) without the prior written consent of the Manager shall, at the option of said Manager, automatically terminate this Agreement and all rights of Concessionaire hereunder. These restrictions on Transfer shall also apply to assignment of activities, uses, privileges, and obligations authorized under this Agreement. The City's consent to a Transfer shall not include consent to enlarge the Term or modify other material provisions of this Agreement. The City's consent to a Transfer shall not constitute a release of liability of Concessionaire pursuant to the requested Transfer. The City's consent to one such Transfer shall not be deemed a consent to subsequent Transfers. The term "Concessionaire" shall include an assignee or sublessee from Concessionaire on any assignment or sublease approved by the City, but no such assignment or sublease shall be approved or shall have any effect, unless Concessionaire and its proposed assignees or sublessee shall thereafter be jointly bound thereby as Concessionaire hereunder.

14.13. NONDISCRIMINATION

In connection with the performance of work under this Agreement, Concessionaire agrees not to refuse to hire, discharge, promote, demote, or to discriminate in matters of compensation against any person otherwise qualified solely because of race, color, religion, national origin, gender, age, military status, sexual orientation, marital status, or physical or mental disability. Concessionaire further agrees to insert the foregoing provision in all subcontracts hereunder.

14.14. NOT PARTNERSHIP

It is understood and agreed by and between the Parties hereto that the status of Concessionaire shall be that of an independent contractor. Notwithstanding the provisions herein for payment by Concessionaire to City of sums based upon a percentage of Gross Revenues, it is further expressly understood and agreed that the City shall not be construed by a third party or held by Concessionaire to be a partner, associate, or joint venture partner of Concessionaire in the conduct of its business. Concessionaire shall at all times have the status of an independent contractor. The City does not intend nor shall it be construed that Concessionaire, its employees, or sub-contractors are employees or officers of the City under Chapter 18 of the Revised Municipal Code or for any purpose whatsoever with any right or City authority to impose tort or contractual liability upon the City. Concessionaire has no authority to bind the City on any contractual matters. As required by Charter and Ordinance, only the City may issue final approval of all contractual matters that obligate the City.

14.15. NOTICES

All notices required to be given to the City or Concessionaire hereunder shall be in writing and sent by certified mail, return receipt requested, as follows:

To the City:	Manager of Aviation Denver International Airport Airport Office Building, 9th Floor 8500 Peña Boulevard Denver, CO 80249-6340
With a copy to:	Deputy Manager of Aviation, Commercial Denver International Airport Airport Office Building, 9th Floor 8500 Peña Boulevard Denver, CO 80249-6340
To Concessionaire:	At the address and to the attention of the person so designated on the Summary Page.

Either Party hereto may designate in writing from time to time the address of substitute or supplementary persons within the State of Colorado to receive such notices. The effective date of service of any such notice shall be the date such notice is mailed or delivered to the intended Party.

14.16. PARAGRAPH HEADINGS

The captions, section numbers, and article numbers appearing in this Agreement are inserted only as a matter of convenience and in no way define or limit, construe, or describe the scope or intent of any provision of this Agreement nor in any way affect this Agreement.

14.17. PATENTS AND TRADEMARKS

Concessionaire represents that it is the owner of or fully authorized to use any services, processes, machines, articles, marks, names, or slogans used by it in its operations under this

Agreement. Concessionaire will not utilize any protected patent, trademark, or copyright, including any patents, trademarks, or copyrights owned by the City, in its operations under this Agreement, unless it has obtained proper permission, all releases, and other necessary documents. Concessionaire agrees to save and hold harmless the City, its officers, employees, agents, and representatives from any loss, liability, expense, suit, or claim for damages in connection with any actual or alleged infringement of any patent, trademark, or copyright arising from any alleged or actual unfair competition or other similar claim arising out of the operations of Concessionaire under this Agreement.

14.18. COLORADO OPEN RECORDS ACT

A. Agreement Subject to Colorado Open Records Act. Concessionaire acknowledges that the City is subject to the provisions of the Colorado Open Records Act, Colorado Revised Statutes §24-72-201 et seq. Concessionaire acknowledges that all documents prepared or provided by Concessionaire under this Agreement may be subject to the provisions of the Colorado Open Records Act. Any other provision of this Agreement notwithstanding, including exhibits, attachments, and other documents incorporated into this Agreement by reference, all materials, records, and information provided by Concessionaire to the City shall be considered confidential by the City only to the extent provided in the Open Records Act, and Concessionaire agrees that any disclosure of information by the City consistent with the provisions of the Open Records Act shall result in no liability of the City. Concessionaire agrees that it will fully cooperate with the City in the event of a request for disclosure or a lawsuit arising under such act for the disclosure of any documents or information, which Concessionaire asserts is confidential and exempt from disclosure.

B. Indemnification in Event of Intervention. In the event of a request to the City for disclosure of such information, time, and circumstances permitting, the City will make a good faith effort to advise Concessionaire of such request in order to give Concessionaire the opportunity to object to the disclosure of any material Concessionaire may consider confidential, proprietary, or otherwise exempt from disclosure. In the event of the filing of a lawsuit to compel disclosure, the City will tender all such material to the court for judicial determination of the issue of disclosure. Concessionaire agrees it will either waive any claim of privilege or confidentiality or intervene in such lawsuit to protect materials Concessionaire does not wish disclosed. If Concessionaire chooses to intervene in such a lawsuit and oppose disclosure of any materials, Concessionaire agrees to defend, indemnify, and save and hold harmless the City, its officers, agents, and employees from any claim, damages, expense, loss, or costs arising out of Concessionaire's intervention including prompt reimbursement to the City of all reasonable attorney fees, costs, and damages that the City may incur directly or may be ordered to pay by such court.

14.19. SECURITY

A. Concessionaire's Security Procedures. Concessionaire shall submit its written operating and security procedures for its operations hereunder to the City for review at least thirty (30) days prior to the Rent Commencement Date, or if Concessionaire Opens for Business earlier than the Required Opening Date, at least seven (7) days prior to the Required Opening Date. Concessionaire shall revise such operating and security procedures as necessary to obtain the City's approval.

B. Compliance. Concessionaire shall cause its officers, contractors, agents, and employees to comply with all existing and future security regulations adopted by the City pursuant to Part 107, Federal Air Regulations of the Federal Aviation Administration, as it may be amended from time to time. With respect to Airport security, it is a material requirement of this Agreement that Concessionaire shall comply with all rules, regulations, written policies, and authorized directives from the City and/or the Transportation Security Administration (“TSA”). Violation by Concessionaire or any of its employees of any rule, regulation, or authorized directive from the City or TSA with respect to Airport Security shall constitute a material breach of this Agreement. Any person who violates such rules may be subject to revocation of his/her access authorization. Concessionaire will fully reimburse the City for any fines or penalties levied against the City for security violations as a result of any actions on the part of Concessionaire, its agents, contractors, suppliers, guests, customers, or employees. Concessionaire will also fully reimburse the City for any attorney fees or related costs paid by the City as a result of any such violation.

C. Changes in Security Status. Concessionaire understands and acknowledges that its ability to remain open and sell its authorized items under this Agreement is subject to changes in alert status as determined by TSA, which is subject to change without notice. If the security status of the Airport changes at any time during the Term (or any extended term) of this Agreement, Concessionaire shall take immediate steps to comply and assist its employees, agents, independent contractors, invitees, successors, and assigns in complying with security modifications that occur as a result of the changed status. At any time, Concessionaire may obtain current information from the Airport Security Office regarding the Airport’s security status in relation to Concessionaire’s operations at the Airport.

D. Access Keys and Badges. Concessionaire shall return to the City all access keys or access badges issued to it for any area of the Airport, whether or not restricted once this Agreement expires or terminates or upon the City’s demand. If Concessionaire fails to do so, Concessionaire shall be liable to reimburse the City for all the City’s costs for work required to prevent compromise of the Airport security system. The City may withhold funds in the amount of such costs from any amounts due and payable to Concessionaire under this Agreement.

14.20. SEVERABILITY

If any provision in this Agreement is held by a court to be invalid, the validity of other provisions herein which are severable shall be unaffected.

If a court of competent jurisdiction determines that any term, covenant, or condition of this Agreement or the application of this Agreement to any person or circumstance shall to any extent be determined to be invalid or unenforceable, the remainder of this Agreement or the application of such term, covenant, or condition to persons or circumstances, other than those as to which it is held invalid or unenforceable, shall not be affected thereby. Each term, covenant, or condition of this Agreement shall be valid and be enforced to the fullest extent permitted by Law.

14.21. THIRD PARTIES

This Agreement does not, and shall not be deemed or construed to, confer upon or grant to any third party or parties (except parties to whom the Concessionaire may assign this Agreement in accordance with the terms hereof, and except any successor to the City) any right to claim

damages or to bring any suit, action or other proceeding against either the City or the Concessionaire because of any breach hereof or because of any of the terms, covenants, agreements and conditions herein.

14.22. AUTHORITY TO ENTER INTO AGREEMENT

The Party of the Second Part represents that it is a duly constituted limited liability company, corporation, or partnership authorized to conduct business in the State of Colorado. Each person signing and executing this Agreement on behalf of Concessionaire represents and warrants that pursuant to any proper, appropriate, and official motion, resolution, or action passed or taken, s/he possesses the legal authority to validly and legally bind Concessionaire to all the terms, performances, and provisions of this Agreement. Upon the City's request, Concessionaire agrees that it shall deliver to the City a certified copy of any such resolutions of Concessionaire's directors authorizing the execution and delivery of this Agreement. Such resolutions must be certified by Concessionaire's Secretary or Concessionaire's members authorized by Concessionaire's Managing member.

14.23. NO CONSTRUCTION AGAINST DRAFTING PARTY

This Agreement is the result of arm's length negotiations between the City and Concessionaire. Concessionaire and its professional advisors have reviewed this Agreement. The City, Concessionaire, and their separate advisors believe that this Agreement is the product of all of their efforts, that it expresses their agreement, and that it should not be construed against any Party merely because this Agreement or any of its provisions were prepared by a particular Party.

14.24. USE, POSSESSION, OR SALE OF ALCOHOL OR DRUGS

Concessionaire, its officers, agents, and employees shall cooperate and comply with the provisions of the Federal Drug-Free Workplace Act of 1988 and Denver Executive Order No. 94, or any successor thereto, concerning the use, possession, or sale of alcohol or drugs. Except as may be otherwise authorized by this Agreement, Concessionaire shall also prohibit consumption of alcohol within the Concession Space. Violation of these provisions or refusal to cooperate with implementing this alcohol and drug policy can result in the City barring Concessionaire from City facilities or participating in City operations.

14.25. CITY SMOKING POLICY

Concessionaire agrees that it will prohibit smoking by its employees and the public in the Concession Space. Concessionaire further agrees to not sell or advertise tobacco products. Concessionaire acknowledges that smoking is not permitted in Airport buildings and facilities except for designated smoking lounges. Concessionaire and its officers, agents, and employees shall cooperate and comply with the provisions of the City's Executive Order No. 99 dated December 1, 1993, Executive Order No. 13 dated July 31, 2002, the provisions of D.R.M.C., §§ 24-301 to 317 et. seq., and the Colorado Clean Indoor Air Act, C.R.S. §§ 25-14-201 et. seq.

14.26. WAIVER OF CLAIMS

Each Party hereby waives any claim against the other Party for consequential, special, or punitive damages, including loss of anticipated profits caused in suits or proceedings attacking the validity of all or part of this Agreement. Such proceedings include any judgment or award in any suit declaring this Agreement null, void, or voidable; delaying this Agreement or any part of it from being carried out; or the enforcement of this Agreement.

14.27. JOINT AND SEVERAL LIABILITY

If Concessionaire is a partnership or other business organization, each member shall be deemed to be jointly and severally liable if such members are subject to personal liability.

14.28. BROKER'S COMMISSION

Concessionaire represents and warrants that it has not caused nor incurred any claims for brokerage commissions or finder's fees in connection with the execution of this Agreement. Concessionaire shall indemnify and hold the City harmless against all liabilities arising from any such claims caused or incurred by it (including the cost of attorney fees in connection therewith).

14.29. NO LIMIT ON CITY'S POWERS

Nothing in this Agreement shall limit in any way the power and right of the City to exercise its governmental rights and powers, including its powers of eminent domain.

14.30. WAR OR NATIONAL EMERGENCY

During a time of war or national emergency, the City shall have the right to lease the Airport or any part thereof to the United States Government for military use. If any such lease is executed, the provisions of this Agreement insofar as they are inconsistent with such an agreement with the United States Government shall be suspended. In such event, a just proportionate part of the Monthly Guarantee hereunder shall be abated.

14.31. SURVIVAL OF CERTAIN CONTRACT PROVISIONS

The Parties understand and agree that all terms and conditions of this Agreement, (such as the indemnity agreement set forth herein) which by reasonable implication contemplate continued performance or compliance beyond the termination of this Agreement (by expiration of the Term (or any extended term) or otherwise), shall survive the expiration or earlier termination of this Agreement and shall continue to be fully enforceable as provided herein.

14.32. AGREEMENT AS COMPLETE INTEGRATION; AMENDMENTS

The City and Concessionaire each warrant and represent to each other that this Agreement constitutes their legal, valid, and binding obligation and that the provisions herein, including all Exhibits and other documents incorporated by reference, contain the entire agreement and are intended as the complete integration of all understandings between the Parties. No prior or contemporaneous addition, deletion, or other amendment hereto shall have any force or effect whatsoever unless embodied in a written amendment to this Agreement properly executed by the Parties. No subsequent novation, renewal, addition, deletion, or other amendment hereto shall have any force or effect unless embodied in a written amendment or other agreement

executed with the same formality as this Agreement. This Agreement and any subsequent written amendments or other alteration not requiring formal amendment as set forth in this Agreement, including **Exhibit D** as modified from time to time, form the entire agreement between the parties and are fully binding on the Parties, their successors, and assigns. Both Parties agree that no oral representations by any officer, official, employee, or agent of the City and no other agreement at variance with the terms and conditions of this Agreement have been made.

14.33. FINAL APPROVAL; COUNTERPARTS; ELECTRONIC SIGNATURES

This Agreement may be executed in two or more counterparts. Each counterpart will be deemed an original signature page to this Agreement. This Agreement is expressly subject to and shall not be or become effective or binding on the City until approved by the City Council, if so required by the City's Charter, and fully executed by all signatories of the City and County of Denver. This Agreement may be signed electronically by the Parties in the manner specified by the City.

[SIGNATURE PAGES FOLLOW]

Contract Control Number: 201311261

Contractor Name: CI/EL-ROI RMCF JV

By

CONCESSIONS INTERNATIONAL, LLC

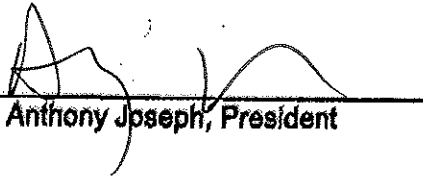
By: 
Anthony Joseph, President

and

MULUYE HAILEEMARIAM dba EL-Roi Jewelry Fashion

By:  MULUYE
A Colorado resident and sole proprietor



Contract Control Number:

IN WITNESS WHEREOF, the parties have set their hands and affixed their seals at Denver, Colorado as of

SEAL

CITY AND COUNTY OF DENVER

ATTEST:

By _____

APPROVED AS TO FORM:

REGISTERED AND COUNTERSIGNED:

By _____

By _____

By _____



EXHIBIT A
CONCESSION SPACE PLAN

E34.1

E34.6

E35

E36

E37

E37.4

E37.9

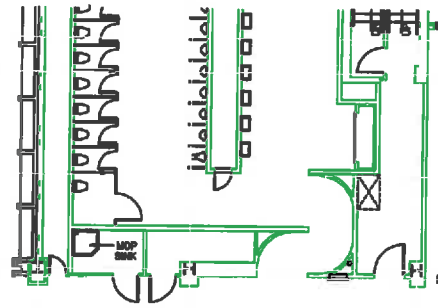
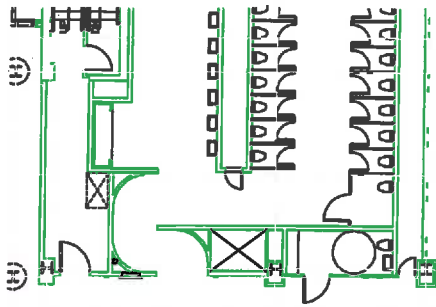

N5
N4
N3
N2.2
N2



N1
NS
S1

Rocky Mt. Chocolate Factory
R18-1-3-E36-S5-1
816.7 sq. ft.

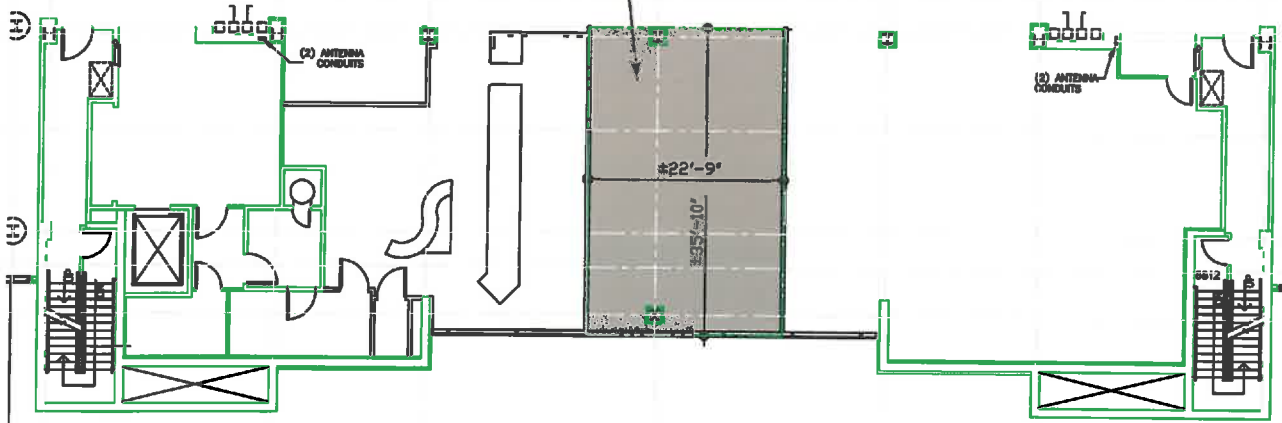

S2
S2.2
S3
S4
S5

- CONC. WALL (BY CITY)
- STUD/GYPSUM WALL (BY CITY)
- GLASS WALL (BY CITY)
- TENANT LEASE LINE

(H) (S) COLUMNS
NIC = Not Included
(In Lease or Sq. Ft. Calc.)

SCALE 1" = 20.00'



NOTE:

This exhibit depicts only approximate dimensions and square footage of leased area based upon planning data and is not intended to show dimensions for construction details.

Ronald Horn
MANAGER OF DESIGN

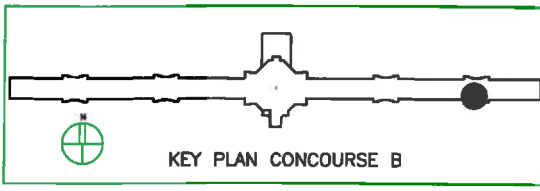

REVISED

DENVER INTERNATIONAL AIRPORT	
EXHIBIT A	
Concourse B Conc. Level	
CI/EL ROI RMCF, JV	
CC#: COIN	DATE: 8/27/13

EXHIBIT B
DISADVANTAGED BUSINESS ENTERPRISE PARTICIPATION

EXHIBIT B

DISADVANTAGED BUSINESS ENTERPRISE PARTICIPATION

CI/EL-ROI RMCF, JV

SECTION 1 – GENERAL. Except as the context otherwise requires and unless otherwise expressly provided herein, the capitalized terms in this *Exhibit* to the Agreement shall have the same meaning as any similarly capitalized terms defined in the Agreement or in any exhibit thereto.

SECTION 2: ACDBE OBLIGATION

A. Nondiscrimination. This Agreement is subject to the requirements of the U.S. Department of Transportation's ("DOT") regulations, 49 CFR Part 23 and 26 as amended. Concessionaire agrees that it will not discriminate against any business owner because of the owner's race, color, national origin, or sex in connection with the award or performance of any concession agreement, management contract, or subcontract, or other agreement covered by 49 CFR Part 23 and 26.

Concessionaire agrees to include the above statements in any subsequent concession agreement or contract covered by 49 CFR Part 23 and 26 that it enters into and to cause those businesses to similarly include the statements in further agreements.

Concessionaire further agrees that it shall comply with all Airport Concession Disadvantaged Business Enterprise ("ACDBE") regulations of the DOT as they may be adopted or amended from time to time during the Term.

B. ACDBE Responsibilities. As a condition of eligibility for financial assistance from the Federal Aviation Administration ("FAA"), the City through its Division of Small Business Opportunity ("DSBO") developed and implemented an ACDBE Program for Denver International Airport. The ACDBE Program was developed and implemented in accordance with DOT's Final Rule 49 CFR Part 23.

The City's Director of DSBO has been delegated as the ACDBE Liaison Officer for Denver International Airport. In that capacity, the Director of DSBO is responsible for compliance with all aspects of the ACDBE program. The Director of DSBO has established ACDBE goals for the Airport and may also establish ACDBE concession specific goals as a percentage of annual gross receipts for this Agreement. The applicable concession specific ACDBE goal, if any, is stated on the Summary Page of this Agreement. The stated goal was included in a competitive solicitation process in which Concessionaire was recommended to operate in the Concession Space. During that process, Concessionaire submitted its required Form C to meet the ACDBE goal. DSBO found the required Form C to be responsive and thus, required Form C is attached to this Agreement as Section C of *Exhibit G, ACDBE Commitment Form* and incorporated herein by reference. During the Term of this Agreement, Concessionaire agrees that it shall in good faith make every effort to meet the stated ACDBE goal.

To carry out its ACDBE responsibilities as they are described in this Agreement and in the Required Form C, Concessionaire agrees to assign this responsibility to a high level company official accountable directly to Concessionaire's chief executive officer. Concessionaire

acknowledges that if its actions or failure to act violates its ACDBE responsibilities under this Agreement or the ACDBE regulations of the DOT as they may be adopted or amended from time to time, such actions may constitute a material breach of this Agreement and shall entitle the City to exercise any or all of its rights and remedies at law or equity.

C. Good Faith Effort Requirement. In the event ACDBE requirements change (including but not limited to a request to transfer or assign this Agreement to a non-ACDBE certified assignee if Concessionaire is a certified ACDBE, a change in ownership if Concessionaire is part of a joint venture, a change in the original list of subcontractors/sub-concessionaires submitted with Concessionaire's proposal, or a change in a certified DBE supplier or service provider if a replacement is required for any reason), Concessionaire shall forthwith submit to DSBO and to Concessions Management a modified ACDBE Good Faith Effort together with a written request for review and approval, setting forth the circumstances in sufficient detail and with appropriate documentation to explain the necessity for the change. In every case, Concessionaire shall substitute a DSBO certified DBE or ACDBE, and if it cannot, then Concessionaire shall be required to document that it made good faith efforts to do so. Concessionaire acknowledges and agrees that no change to its ACDBE participation is authorized until approved in writing by the Director of DSBO with concurrence by the authorized representative of the Manager.

D. Monthly Report Requirement. Concessionaires who have promised to meet ACDBE goals utilizing suppliers of goods or services shall submit monthly reports to DSBO identifying all ACDBE firms utilized and the dollar amounts spent with such firms during the preceding month. These reports shall be on a form satisfactory to DSBO and delivered to DSBO no later than the 10th day of the following month. Concessionaire will be required to submit to DSBO the following ACDBE information: (1) the names and addresses of ACDBE firms and/or suppliers that will participate in the concession; (2) a description of the work that each ACDBE will perform; (3) the dollar amount each ACDBE firm is participating; (4) written and signed documentation of a commitment to use an ACDBE whose participation meets a contract goal ("ACDBE Commitment Form"); and (5) written and signed confirmation from the ACDBE that it is participating in the concession as provided in the prime concessionaire's commitment. Whenever a Joint Venture is used to meet ACDBE goals, Concessionaire shall submit to DSBO an annual financial statement for the preceding year indicating compensation, profit sharing, capital contributions of ACDBE partners, or any other financial information as requested by DSBO relevant to determining ACDBE compliance. Concessionaire shall also disclose annually the ACDBE partner's management involvement and its role in decision making. The annual financial statement shall be on a form satisfactory to DSBO and delivered to DSBO no later than February 28th of the following year.

EXHIBIT C

INSURANCE CERTIFICATE

PLEASE GIVE THIS FORM TO YOUR INSURANCE AGENT FOR COMPLETION.

**CITY AND COUNTY OF DENVER
INSURANCE REQUIREMENTS - DEPARTMENT OF AVIATION**

Certificate Holder:

CITY AND COUNTY OF DENVER
Attn: Risk Management, Suite 8810
Manager of Aviation
Denver International Airport
8500 Pena Boulevard, Room 8810
Denver CO 80249

**CONTRACT NAME & NUMBER TO WHICH THIS INSURANCE APPLIES: 201311261 Food and Beverage
Concession @ DIA**

I. MANDATORY COVERAGE

Colorado Workers' Compensation and Employer Liability Coverage

Coverage: COLORADO Workers' Compensation

Minimum Limits of Liability (In Thousands)

WC Limits: \$100, \$500, \$100

And Employer's Liability Limits:

Any Policy issued under this section must contain, include or provide for the following:

1. All States Coverage or Colorado listed as a covered state for the Workers' Compensation
2. Waiver of Subrogation and Rights of Recovery against the City and County of Denver (the "City"), its officers, officials and employees.

Commercial General Liability Coverage

Coverage: Commercial General Liability (coverage at least as broad as that provided by ISO form CG0001 or equivalent)

Minimum Limits of Liability (In Thousands):

Each Occurrence:	\$1,000
General Aggregate Limit:	\$2,000
Products-Completed Operations Aggregate Limit:	\$2,000
Liquor Liability	\$2,000
Personal & Advertising Injury:	\$1,000
Fire Damage Legal - Any one fire	\$1,000

Any Policy issued under this section must contain, include or provide for the following:

1. City, its officers, officials and employees as additional insureds, per ISO form CG2010 and CG 2037 or equivalents.
2. Coverage for defense costs of additional insureds outside the limits of insurance, per CG0001.
3. Liability assumed under an Insured Contract (Contractual Liability).
4. The full limits of coverage must be dedicated to apply to this project/location, per ISO form CG2503 or equivalent.
5. Waiver of Subrogation and Rights of Recovery, per ISO form CG2404 or equivalent.
6. If liquor is to be sold or distributed, then Liquor Liability, with City as an additional insured is required.

EXHIBIT C

- 7. Separation of Insureds Provision required
- 8. General Aggregate Limit Applies Per: Policy ___ Project ___ Location ____, if applicable

Business Automobile Liability Coverage

Coverage: **Business Automobile Liability (coverage at least as broad as ISO form CA0001)**

Minimum Limits of Liability (In Thousands): **Combined Single Limit** **\$1,000**

Any Policy issued under this section must contain, include or provide for the following:

- 1. Symbol 1, coverage for any auto. If no autos are owned, Symbols 8 & 9, (Hired and Non-owned) auto liability.
- 2. If this contract involves the transport of hazardous cargo such as fuel, solvents or other hazardous materials may occur, then Broadened Pollution Endorsement, per ISO form CA 9948 or equivalent and MCS 90 are required.

II. ADDITIONAL COVERAGE

Umbrella Liability

Coverage:

Umbrella Liability, Non Restricted Area Minimum Limits of Liability (In Thousands)	Each Occurrence and aggregate	\$1,000
---	--------------------------------------	----------------

Umbrella Liability, Unescorted airside access Minimum Limits of Liability (In Thousands)	Each Occurrence and aggregate	\$9,000
---	--------------------------------------	----------------

Any Policy issued under this section must contain, include or provide for the following:

- 1. City, its officers, officials and employees as additional insureds.
- 2. Coverage in excess of, and at least as broad as, the primary policies in sections WC-1, CGL-1, and BAL-1.
- 3. **If operations include unescorted airside access at DIA, then a \$9 million Umbrella Limit is required.**

Property Coverage

Coverage: Personal Property, Contents, Fixtures, Tenant Improvements and Betterments

Minimum Limits of Liability (in Thousands):

- o 100% of the Replacement Cost value of Personal Property, Contents, Fixtures, Tenant Improvements and Betterments
- o Covered Cause of Loss – Special Form including glass coverage and signs
- o Replacement Cost Endorsement

Any Policy issued under this section must contain, include or provide for the following:

- 1. City, its officers, officials and employees as additional insureds.
- 2. Waiver of Subrogation Applies to City as Landlord for any protected Landlord Property.
- 3. In the event of payment of any Loss involving Tenant Improvements and Betterments, permanent fixtures, etc, the insurance carrier shall pay the City (as Landlord) its designee first for said property

EXHIBIT C

loss

III. ADDITIONAL CONDITIONS

It is understood and agreed, for the benefit of the City, that the following additional conditions shall apply to all coverage specified herein:

1. All coverage provided herein shall be primary and any insurance maintained by the City shall be considered excess.
2. The City shall have the right to verify or confirm, at any time, all coverage, information or representations contained herein, and the insured and its undersigned agent shall promptly and fully cooperate in any such audit the City may elect to undertake.
3. Advice of renewal is required
4. All insurance companies issuing policies hereunder must carry at least an A-VI rating from A.M. Best Company or obtain a written waiver of this requirement from the City's Risk Administrator.
5. Compliance with coverage requirement by equivalent herein must be approved in writing by the City's Risk Administrator prior to contract execution.
6. No changes, modifications or interlineations on these insurance requirements shall be allowed without the review and approval of the Risk Administrator prior to contract execution.
7. The Insured named above shall promptly advise the City in the event any general aggregates or other aggregate limits are reduced below the required per occurrence limits. At the Insured's expense, the Insured will reinstate the aggregate limits to comply with the minimum requirements and shall furnish to the City a new Certificate showing such coverage is in force.

IV. NOTICE OF CANCELLATION

It is understood and agreed that should any Policy issued hereunder be cancelled or non-renewed before the expiration date thereof, or sustain a material change in coverage adverse to the City, the issuing company or its authorized Agent shall give notice to the Department of Aviation in accordance with policy provisions.

EXHIBIT D
CONFIRMATION OF ACTUAL DATES AND TERM

EXHIBIT D

CONFIRMATION OF ACTUAL DATES AND TERM

Pursuant to the requirements of the Concession Agreement, the City and Concessionaire agree that some of the dates on the Summary Page may have changed, and therefore, the actual dates described in the Concession Agreement are as follows:

Concessionaire Name: CI/EL-ROI RMCF, JV

Concession Location: Concourse B West Outboard Subcore

Contract Id No: 201311261-00

Date this Exhibit is to be effective:

Effective Date of Concession Agreement (“Date of Execution”):

	Initial Dates Stated on Summary Page	Revised Initial Dates Based on Date of Execution	Revised Actual Date based on Delivery Date	Actual Dates Based on Construction Delay	Final Dates Based on Rent Commencement Date (including Bonus Term Days)
Preliminary Design Due Date:	30 calendar days from the Effective Date or as documented by <i>Exhibit D.</i>				
NTP Documents Deadline:	150 calendar days from the Effective Date or as documented by <i>Exhibit D.</i>				
Target Possession Date:	180 calendar days from the Effective Date or as documented by <i>Exhibit D.</i>				
Delivery Date:					
*Date Bonus Half - Rent Actually Commenced: <small>(Only if the Early Opening Incentive defined in §4.01B)</small>					

applies)					
*No. Bonus Days Added to term: <small>(Only if §4.01B applies)</small>					
No. Delay Days Added:					
Required Opening Date:	300 calendar days from the Effective Date or as documented by Exhibit D.				
Date Concession Actually Opens for Business:					
Rent Commencement Date:	300 calendar days from the Effective Date or as provided by §5.03 and documented by Exhibit D.				
*Renovation Completion Date(s) <small>(Applies only if the term exceeds five years)</small>	42 months from the Rent Commencement Date or As provided in §7.09 and documented by Exhibit D				
Other Dates:					

Expiration Date: _____

To the extent that any of the dates set forth herein vary from, modify, or supplement the provisions of the Concession Agreement, the provision contained herein shall prevail and control.

Concessionaire:

Countersigned and Approved by the City:
Kim Day, Manager of Aviation

By: _____
Title: _____
Date: _____

By: _____
Title: _____
Date: _____

EXHIBIT E
INITIAL PROPOSED ITEMS AND PRICES

EXHIBIT E PROPOSED MENU AND PRICING

Concessionaire: Rocky Mountain Chocolate Factory
 Location: BCON

Date: 8/1/2013

Item No.	Concessionaire's Proposed Product/ Service (Detailed Description of item, product, or service, portion/product size, accoutrements, quantity, time etc.)	COMPARABLES					Wholesale Cost	PROPOSED PRICE
		Store #1 Price	Store #2 Price	Store #3 Price	Average	10%		
1	Chocolates by the pound (fudge, SF, Barks, Nuts, brittles, chocolate dipped fruits, etc.)						8.90-26.95	
2	Fancy gift boxed candies						6.55-62.32	
3	Baked dog bone treats, sold separately or as a "barkers dozen"						25-75¢ ea; 6.75/doz	
4	Quality High Cacao content and SF Candy Bars						3.08-5.81	
5	Goodie Bags						10.87-12.63	
6	mascot stuffed bear						30.75	
7	novelty candies						3.95-25.85	
8	Hand dipped, coated Apples						4.86-8.34	
9	Bottled Soda 20oz						1.90	
10	Bottled Water 16.9 oz						1.90	
11								
12								
13								
14								
15								

EXHIBIT F
COMPARABLE STREET PRICING

LIST OF COMPARABLE STORE LOCATIONS

Concessionaire Name: Rocky Mountain Chocolate Factory

Location: Concourse B

DESCRIPTION OF CONCESSIONAIRE'S CONCEPT: Fancy hand-crafted chocolate confections, candy-coated apples, novelty gift boxes and high quality chocolate bars.

CONCESSIONAIRES SHALL LIST COMPARABLE BUSINESS NAME(S), ADDRESSES, JUSTIFICATION OF HOW COMPARABLE IS SIMILAR TO CONCESSIONAIRE, TELEPHONE NUMBER(S), AND CORRESPONDING ITEM NUMBERS	
Comparable Business Name & Address	Description/Justification of Use as Comparable
1. Rocky Mountain Chocolate Factory	Use any three RMCF stores located within the seven-county Metro Area
2. Three comparable establishments agreed upon between Concessionaire and City.	
3.	
4.	
5.	
6.	
7.	
8.	
9.	

EXHIBIT G
ACDBE COMMITMENT FORM

ACDBE PARTICIPATION AND COMMITMENT FORM

DENVER INTERNATIONAL AIRPORT
CITY AND COUNTY OF DENVER
DIVISION OF SMALL BUSINESS OPPORTUNITY**A. BACKGROUND**

It is the policy of the City that airport concession disadvantaged business enterprises (ACDBEs) as defined in 49 CFR Part 23 shall have maximum opportunity to participate in the performance of contracts financed in whole or in part with federal funds. Airport Concessions Disadvantaged Business Enterprise (ACDBE) participation is highly encouraged in all concession opportunities. The City and County of Denver's Division of Small Business Opportunity (DSBO) has developed and implemented an ACDBE program for Denver International Airport as required under Department of Transportation 49 CFR Part 23. The ACDBE program objective is to ensure full and fair access to concession opportunities for all business and in particular ACDBE business entities. Contracts pertaining to the concession program at Denver International Airport are subject to the requirements of 49 CFR Part 23.

The City's Director of DSBO has been delegated as the ACDBE Liaison Officer for Denver International Airport. In that capacity, the Director of DSBO is responsible for compliance with all aspects of the ACDBE program. The Director of DSBO has established ACDBE goals for the Airport and for this concession opportunity. The company shall commit, at a minimum, to meet the ACDBE participation goal as included in the competitive solicitation process and incorporated herein by reference expressed as the percentage of annual gross receipts for this concession opportunity. The Director of DSBO will determine whether a company's proposal for meeting this concession specific goal is responsive at the time the proposal is submitted.

B. OPPORTUNITY SPECIFIC ACDBE REQUIREMENT

For this concession agreement, an ACDBE participation goal of 40% has been established by the DSBO Director. ACDBE participation may be in the form of a joint venture, partnership or other legal arrangement that meets the eligibility standards in 49 CFR Part 23 and as detailed below. The ACDBE goal for this concession opportunity also may be met through the providing of goods and services from certified vendors. A list of ACDBE-certified vendors may be obtained from the Airport's Division of Small Business Opportunity (see below for contact information) and the ACDBE Commitment Form must be included with the proposal. Additionally, if participation is to be obtained from a supplier(s) of goods and services, the ACDBE Letter of Intent Form (including Affirmation) indicating which certified vendor(s) has agreed to participate must be included with the proposal.

All firms upon which ACDBE certification is being relied, whether as company, JV partner, goods and services provider, subconcessionaire, subcontractor, or any other arrangement, must be certified by the City and County of Denver or the Colorado Department of Transportation as an ACDBE at the time Joint Venture paperwork or proposal, whichever is *earlier*, is submitted. The company will be responsible for meeting this goal (or providing documentation of a good faith effort) on or before the deadline for submission of proposals in response to this RFP. The Director of the DSBO will determine whether proposals of participation and/or good faith efforts are responsive.

Certification applications may be obtained on the internet at <http://business.flydenver.com/bizops/smallBus.asp>, or from DSBO, 201 West Colfax Avenue, Dept. 208, Denver, CO 80202, phone (720) 913-1999 or Denver International Airport, Airport Office Building (AOB), Suite 7810, Denver, CO 80249. Questions regarding the certification process should be directed to the ACDBE Certification Coordinator located at DIA at small.business@flydenver.com.

C. ACDBE PARTICIPATION

A company may meet its ACDBE participation commitment utilizing any combination of options stated below, all of which require proof of ACDBE certification by the City and County of Denver, DSBO or the Colorado Department of Transportation (CDOT) pursuant to 49 CFR Part 23. ACDBE certification applications may be obtained via the methods and locations described above.

The amount and type of participation proposed will become a firm commitment in the Lease Agreement, which is monitored by the DSBO and the company agrees, as an express condition of its performance, to comply with the requirements of 49 CFR, Part 23 and the appropriate provisions under the concession agreement. Company acknowledges that its failure to comply with these requirements may result, at the discretion of the DSBO Director, in the imposition of sanctions as provided for in the concession agreement.

Options for meeting the ACDBE commitment are:

- 1) 100 % ACDBE participation: The Concession is solely owned and operated by an ACDBE firm (letter of intent not necessary).
- 2) Percentage Participation: A designated percentage of the business to be owned operated and/or maintained by an ACDBE through sub-contract, sub-lease or joint venture arrangements.**
- 3) Percentage of Goods/Services towards Vendor Purchases: A designated percentage of the gross revenue committed to the purchase of goods and services from ACDBE certified vendors. A list of DBE certified vendors may be obtained from the Airport's DSBO (see below for contact information).
- 4) Other Legal Arrangement: For this option, a company may propose some other legal arrangement as long as it meets the eligibility standards in 49 CFR Part 23.

*** Joint Venture Agreements: For purposes of ACDBE participation, joint venture means an association of an ACDBE firm and one or more other firms to carry out a single, for-profit business enterprise, for which the parties combine their property, capital, efforts, skills and knowledge, and in which the ACDBE is responsible for a distinct, clearly defined portion of the work of the contract and whose shares in the capital contribution, control, management, risks, and profits of the joint venture are commensurate with its ownership interest. The Division of Small Business Opportunity considers any entity that is comprised of an ACDBE and one or more other firms to be a joint venture even if the participants do not identify elsewhere as a joint venture. Joint venture entities are not certified as ACDBEs.*

If the company is participating in a joint venture with a certified ACDBE firm, the Joint Venture Eligibility Form and Joint Venture Affidavit contained in this RFP must be completed. (Go to <http://business.flydenver.com/bizops/smallBus.asp> under "CONCESSIONS PROGRAM INFORMATION".)

Note: All firms upon which ACDBE certification is being relied, whether as company, JV partner, goods and services provider, subconcessionaire, subcontractor or any other arrangement, must be certified by the City and County of Denver or the Colorado Department of Transportation as an ACDBE at the time Joint Venture paperwork or proposal, whichever is **earlier**, is submitted.

Questions regarding the certification process, certified vendors, joint venture agreements, subcontractor agreements, or any other ACDBE questions that arise concerning a concession opportunity should be directed via email to the DSBO ACDBE Program Coordinator located at Denver International Airport at small_business@flydenver.com, in person or by letter to DSBO, Denver International Airport, Airport Office Building (AOB), Suite 7810, Denver, CO 80249.

ACDBE participation must be addressed in the proposal and, in the case of the use of an ACDBE as a goods and/or services provider, evidenced by a Letter of Intent signed by each ACDBE participant. The amount and type of participation proposed will become a firm commitment in the Lease Agreement, which is monitored by DSBO and the company agrees, as an express condition of its performance to comply with the requirements of 49 CFR Part 23 and the appropriate provisions under the concession agreement. Company acknowledges

that its failure to comply with these requirements may result, at the discretion of the DSBO Director in the imposition of sanctions as provided for in the concession agreement.

D. ACDBE GOOD FAITH EFFORTS:

The Department of Transportation (DOT) ACDBE regulation found at 49 CFR Part 23 provides for the adoption of a good faith effort goals program. The program is administered by the Airport's DSBO. In order to comply with the proposal requirements of Part 23 a company shall either meet the specific ACDBE goal on the concession opportunity or in the alternative demonstrate that the company has made sufficient good faith efforts to meet the goal in accordance with the good faith effort provisions of Part 23 detailed below.

- 1) If pre-proposal meetings are scheduled by the City at which ACDBEs may be informed of concession opportunities under a given proposal solicitation, attendance at such pre-proposal meetings is mandatory. Companies are responsible for the information provided at these meetings. The good faith effort information must reflect the company's knowledge of the information provided at these meetings.
- 2) Verifications of efforts to subcontract or joint venture, consistent with industry and professional practice, with the ACDBE whom the company has contacted, or who have contacted the company, including the name, address and telephone numbers of all ACDBEs contacted; a description of efforts made to subcontract; a description of efforts made to subcontract; a description of the information provided to ACDBEs regarding the scope of work to be performed by subcontractors and members of a joint venture; and if attempts to subcontract actually occurred, the dates and places of such process and a description of the outcome.
- 3) Verification that, consistent with industry and professional practice, the company gave ACDBEs necessary access to and adequate time to review projected scopes of work and other documents as well as adequate time to prepare subcontractor proposals and/or negotiate joint venture arrangements. The company will also give a statement as to why the company and the ACDBE did not succeed in reaching a subcontractor or joint venture agreement.
- 4) Verification that, reasonably consistent with industry and professional practice, and the company's past practices on similar projects, the company selected appropriate goods and services, and functions and activities of the concession operation, to be performed by ACDBEs in order to achieve the goals, including consideration of structuring the contract into economically feasible units to facilitate meaningful ACDBE participation.

ACDBE COMMITMENT FORM
DENVER INTERNATIONAL AIRPORT
CITY AND COUNTY OF DENVER
DIVISION OF SMALL BUSINESS OPPORTUNITY

SECTION A – COMPANY INFORMATION

Name of Firm: CI/EL-ROI, JV

Address: 566 Wells Street, SW

City: Atlanta

State: Georgia

Zip: 30312

Contact Person: Anthony Joseph

Telephone: 404-614-6865

Email: ajoseph@cintl.com

Is your firm ACDBE Certified: Yes No
 (If Certified, Attach Certification Letter)

SECTION B – ACDBE COMMITMENT

The ACDBE goal on this concession is 40%.

NOTE: The DSBO will only credit ACDBE participation that is certified as such by the City and County of Denver, Division of Small Business Opportunity (DSBO) or the Colorado Department of Transportation.

1. The undersigned company/concessionaire has satisfied the ACDBE concession requirements in the following manner (please check the appropriate space).

- The company is committed to a minimum of 40% ACDBE utilization on this concession contract which meets or exceeds the ACDBE goal on this concession opportunity. The amount and type of participation proposed will become a firm commitment in the Lease Agreement.
- The company, unable to meet the ACDBE goal, is committed to a minimum of click to insert text% ACDBE utilization on this concession contract and submits its documentation demonstrating good faith efforts. The amount and type of participation proposed will become a firm commitment in the Lease Agreement.
- The company is unable to meet the ACDBE goal and submits documentation demonstrating good faith efforts.

2. Identify ACDBE sub-concessionaire, ACDBE joint venture partner, ACDBE equity partnership or other legal ACDBE business arrangement that meets ACDBE goal and eligibility standards in 49 CFR Part 23.

Name & Address ACDBE Firm	Scope of Work to be Performed/Provided	% Level of Participation on Concession
Muluye Hailemariam d/b/a EL-ROI Fashion Jewelry	Joint Venture Partner	40%
		%
		%
		%

(Use Additional Sheets if Necessary)

ACDBE UTILIZATION – SUBCONTRACTOR AND/OR VENDOR/SUPPLIERS OPPORTUNITIES

List all actual *and* anticipated subcontractors and/or major vendors/suppliers; include **both** ACDBE and non-ACDBE, to be utilized on the concession (use additional sheets if necessary). Examples: Janitorial services, accounting services, HR services, etc.

NOTE: The DSBO will only credit ACDBE participation that is certified as such by the City and County of Denver, Division of Small Business Opportunity (DSBO) or the Colorado Department of Transportation.

NOTE: **An ACDBE Letter of Intent (Attachment A) must be submitted for all ACDBEs listed below and attach copy of ACDBE Certification Letter for each ACDBE.**

Name and Address of Company	Business Area	Scope of Work/Supplies to be Performed	Estimated Amount (\$)	Identify Sub/Supplier	ACDBE		Attach "ACDBE Letter of Intent" and copy of Certification Letter
					Yes (√)	No (√)	
N/A			\$		<input type="checkbox"/>	<input type="checkbox"/>	<input type="checkbox"/>
			\$		<input type="checkbox"/>	<input type="checkbox"/>	<input type="checkbox"/>
			\$		<input type="checkbox"/>	<input type="checkbox"/>	<input type="checkbox"/>
			\$		<input type="checkbox"/>	<input type="checkbox"/>	<input type="checkbox"/>
			\$		<input type="checkbox"/>	<input type="checkbox"/>	<input type="checkbox"/>
			\$		<input type="checkbox"/>	<input type="checkbox"/>	<input type="checkbox"/>
			\$		<input type="checkbox"/>	<input type="checkbox"/>	<input type="checkbox"/>

(Use Additional Sheets if Necessary)

SECTION C – GOOD FAITH EFFORTS

NOTE: Fill out only, if the ACDBE goal was not achieved.

The following items are minimally considered as good faith efforts and demonstrate specific initiatives made in attempting to achieve the concession specific ACDBE goal. Companies are not limited to these particular areas and may include other efforts deemed appropriate. Please feel free to elaborate on any question below.

Companies submitted a Good Faith Effort in lieu of ACDBE participation, for all or any party of the ACDBE goal, must contact the DSBO office prior to submission of proposal to ensure that all GFE requirements are met and that all necessary documentation is submitted. Failure to do so could result in the GFE being found non-responsive.

GOOD FAITH EFFORT QUESTIONS	Yes (√)	No (√)
1. If applicable, did you attend pre-proposal conference?	<input type="checkbox"/>	<input type="checkbox"/>
2. Did your firm request and obtain a copy of the certified ACDBE firms?	<input type="checkbox"/>	<input type="checkbox"/>
3. Were ACDBE firms contacted or solicited for concession participation?	<input type="checkbox"/>	<input type="checkbox"/>
4. Provide listing of solicited ACDBE firms with whom contact was made? Please identify name of company, contact person, date, phone number and briefly	<input type="checkbox"/>	<input type="checkbox"/>

Describe nature of solicitation. (Include as an Attachment)			
5. Was direct contact made with the City's DSBO office? If yes, please identify date/person contacted and assistance sought. (Include as an Attachment)	<input type="checkbox"/>	<input type="checkbox"/>	
6. Identify all ACDBE support agencies/associations contacted for ACDBE assistance or solicitation (Minority Chambers of Commerce, purchasing councils, contractor groups, etc.). (Please attach copies of solicitation letters of assistance and/or describe, as an Attachment to this section, the personal contact made)	<input type="checkbox"/>	<input type="checkbox"/>	
7. Were concession-related opportunities to this project advertised in minority/women newspapers and trade journals? (If yes, please include a copy of the advertisement or detail the name of the publication(s), date of advertisement and describe the solicitation)	<input type="checkbox"/>	<input type="checkbox"/>	
8. Were copies of concession RFP furnished to any ACDBEs?	<input type="checkbox"/>	<input type="checkbox"/>	
9. Identify efforts made to assist interested ACDBEs in obtaining bonding, insurance, or line of credit. (Please detail any assistance that was provided or if they were referred, to whom)	<input type="checkbox"/>	<input type="checkbox"/>	
10. Discuss efforts made to define additional elements of the work proposed to be performed by ACDBEs in order to increase the likelihood of achieving the ACDBE goal.	<input type="checkbox"/>	<input type="checkbox"/>	
11. List, as an Attachment, all ACDBE negotiations and/or bids received but rejected. Identify company name, contact person, telephone number, date, trade area and the reason for rejecting the proposal or bid.	<input type="checkbox"/>	<input type="checkbox"/>	
12. Discuss any other effort(s) aimed at involving ACDBEs (Include as an Attachment): (a) Identify any specific efforts to divide work, in accordance with normal industry practices, to allow maximum ACBE participation. (b) Discuss joint ventures initiatives, requesting second-tier ACDBE subcontracting, etc., if any. (c) List all other good faith efforts employed, please elaborate.	<input type="checkbox"/>	<input type="checkbox"/>	

SECTION D - AFFIRMATION

I HEREBY AFFIRM THAT THE ABOVE INFORMATION IS TRUE AND COMPLETE TO THE BEST OF MY KNOWLEDGE. I FURHTER UNDERSTAND AND AGREE THAT, THIS DOCUMENT SHALL BE ATTACHED THERTO AND BECOME A BINDING PART OF THE CONCESSION CONTRACT.

NAME AND TITLE OF AUTHORIZED OFFICIAL:

Anthony Joseph, President of Concessions Denver, LLC, managing venturer

SIGNATURE: _____

DATE: April 25, 2013



Joint Venture Affidavit

Office of Economic Development
Division of Small Business Opportunity
Compliance Unit
201 West Colfax Avenue, Dept. 907
Denver, CO 80202
Phone: 720-913-1989
Fax: 720-913-1803

The Undersigned swears that the foregoing statements are correct and include all material information necessary to identify and explain the terms and operation of our joint venture and the intended participation by each joint venturer in the undertaking.

Name of Firm: Concessions International, LLC

Print Name: Anthony Joseph Title President

Signature: [Signature] Date: March 15, 2013

Notary Public

County of Newton State of Georgia My Commission Expires: October 5, 2015

Subscribed and sworn before me this 15 day of March, 2013

Notary Signature: [Signature]

Address: 1269 Saxony Drive, Conyers, Georgia 30013

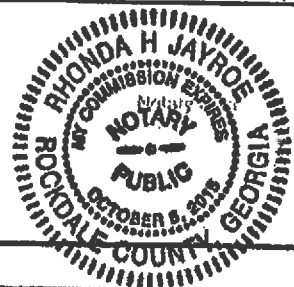

Name of Firm: Muluye Hallemarlam d/b/a El-Roi Fashion Jewelry

Print Name: Muluye Hallemarlam Title President

Signature: [Signature] Date: March 15, 2013

Notary Public

County of Denver State of Colorado My Commission Expires: 12/16/10

Subscribed and sworn before me this 15 day of March, 2013

Notary Signature: [Signature]

Address:

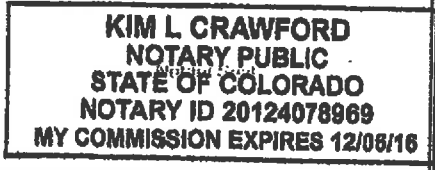

Name of Firm:

Print Name: Title

Signature: Date:

Notary Public

County of State of My Commission Expires:

Subscribed and sworn before me this day of, 20

Notary Signature:

Address:

Notary Seal



DENVER
THE MILE HIGH CITY

**DBE/ACDBE
JOINT VENTURE ELIGIBILITY FORM**

Office of Economic Development
Division of Small Business Opportunity
8500 Pena Boulevard, AOB #7810
Denver, CO 80249
Phone: (303) 342-4358
Fax: (303) 342-2190

Joint Venture means an association of two (2) or more business enterprises to constitute a single business enterprise to perform a City construction or professional design and construction services contract for which purpose they combine their property, capital, efforts, skills and knowledge, and in which each joint venturer is responsible for a distinct, clearly defined portion of the work of the contract, performs a commercially useful function, and whose share in the capital contribution, control, management responsibilities, risks and profits of the joint venture are equal to its ownership interest. Joint ventures must have an agreement in writing specifying the terms and conditions of the relationships between the joint venturers and their relationship and responsibility to the contract.

The Division of Small Business Opportunity (DSBO) requires the following information be provided from participants of a prospective joint venture, to assist DSBO in evaluating the proposed joint venture. This Joint Venture Eligibility form and the Joint Venture Affidavit apply if ACDBEs or DBEs participate in this joint venture.

Please return this form, the Joint Venture Affidavit, a copy of your Joint Venture Agreement and any other documentation stated as required by DSBO in the RFP, mandatory pre-proposal meeting and/or other correspondence relating to the opportunity for which the Joint Venture will be submitted to: Division of Small Business Opportunity, 8500 Pena Blvd, AOB #7810, Denver, CO 80249, at least thirty (30) days prior to proposal deadline and no later than the Joint Venture deadline stated in the RFP.

If you have questions regarding this process, please contact DSBO at 303-342-4358.

Joint Venture Information

Name: CI/EL-ROI, JV (the "JV")		Contact Person: Tanya N. Hairston-Whitner	
Address: Denver International Airport, 8500 Pena Blvd.			
City: Denver	State: CO	Zip: 80249	Phone: 404-614-6862

Joint Venture Participants

Name: Concessions International, LLC ("CI")		Contact Person: Anthony Joseph	
Address 566 Wells Street			
City Atlanta	State: GA	Zip: 30312	Phone: 404-681-0300

% Ownership: 60%	Certifying Entity: N/A	Type Certification & Date: (ACDBE or DBE): N/A
-------------------------	-------------------------------	---

Type of Work for which Certification was granted:

Name: Muluye Hailemariam d/b/a El-Roi Fashion Jewelry ("EL-ROI")		Contact Person: Muluye Hailemariam	
Address: 19877 E. 40th Avenue			
City: Denver	State: CO	Zip: 80249	Phone: 720-297-5671

% Ownership: 40%	Certifying Entity: City and County of Denver	Type Certification & Date: (ACDBE or DBE): ACDBE; July 24, 2012 thru December 28, 2012
-------------------------	---	---

Type of Work for which Certification was granted: **Snack Bars, Fixed Location; Limited Service Restaurants**

General Information

ACDBE/DBE Initial Capital Contributions: **\$10,000.00** **40% of total initial Capital Contribution of \$25,000.00**

Future capital contributions (explain requirements) (attach additional sheets if necessary):

The JV will prepare a schedule which reasonably estimates of any future capital contributions required in connection with the concession agreement, the construction and opening of the facility and provide such schedule to both CI and EL-ROI. EL-ROI will contribute 40% of the capital contribution required and set forth on such schedule.

Source of Funds for the ACDBE/DBE Capital Contributions: **EI-ROI's operating accounts with Wells Fargo**

Describe the portion of the work or elements of the business controlled by the ACDBE or DBE (attach additional sheets if necessary): **See Exhibit "A"**

Describe the portion of the work or elements of the business controlled by non- ACDBE or DBE: (attach additional sheets if necessary) See Exhibit "A"

JOINT VENTURE ELIGIBILITY FORM

General information

Describe the ACDBE or DBE's involvement in the overall management of the joint venture (e.g., participation on a management committee or managing board voting rights, etc.) (attach additional sheets if necessary)

On a monthly basis EL-ROI and CI will meet to discuss the overall management and the financials for the JV. In the event there are overall management or governance decisions that are required, EL-ROI will have one member of the NDM Committee (as defined below) which committee is responsible for the overall management of the JV. Certain major decisions (as defined in the JV Agreement) require unanimous consent of the venturers.

Describe the ACDBE or DBE's share in the profits of the joint venture:

EL-ROI will receive 40% of the profits of the JV.

Describe the ACDBE or DBE's share in the risks of the joint venture:

EL-ROI will be required to incur 40% of the any financial losses and pursuant to an indemnification in the JVs agreement, EL-ROI will be required to share in 40% any liability incurred under any concession agreement entered into by the JV.

Describe the roles and responsibilities of each joint venture participant with respect to managing the joint venture (use additional sheets if necessary):

a. ACDBE or DBE joint venture participant: Based on the allocation of responsibilities set forth on Exhibit "A", each Venturer will have certain management services for which it is responsible. Consequently, with respect to the management services for which EL-ROI is responsible a committee (the "EL-ROI Committee") with two representatives from EL-ROI and one representative from CI will make all of the decisions.

b. Non-ACDBE or DBE joint venture participant: With respect to the management services for which CI is responsible a committee ("NDM Committee") with two representatives from CI and one representative from EL-ROI will make all the decisions.

Describe the roles and responsibilities of each joint venture participant with respect to operation of the joint venture (use additional sheets if necessary):

a. ACDBE or DBE joint venture participant: EL-ROI will be responsible for (i) hiring and managing the general manager who is responsible for the day to day management of the facility and serves as the on-site representative of the JV; (ii) conduct quarterly market based surveys; (iii) perform all required operations for pre-opening the facility; (iv) conduct orientation for all employees; (v) conduct Level 1 training; (vi) on-site training; (vii) identify staffing needs, post position openings, and interview/recommend candidates for hire; (viii) ensure new hire docs are verified and processed; (ix) managing the badging process; (x) order and distribute compliance postings for business units; and (xi) community engagement and company donations.

b. Non-ACDBE or DBE joint venture participant: CI will be responsible for: (i) Operations Procedures and Policies; (ii) Construction Management; (iii) Menu Development; (iv) Information & Technology; (v) Legal matters; (vi) Quality Assurance; (vii) Accounting; (viii) HR- Corporate Training; and (ix) Loss Prevention.

Which firm will be responsible for accounting functions relative to the joint venture's business? Concessions International, LLC

Explain what authority each party will have to commit or obligate the other to insurance and bonding companies, financing institutions, suppliers, subcontractors, and/or other parties? With respect to decisions made in the ordinary course of business for the allocated services, the venturer responsible for such service and its respective committee will make the decisions for insurance, bonding companies, suppliers, subcontractors, and/or other parties. With respect to financing, the decision will be by unanimous consent of the venturers.

Please provide information relating to the approximate **number** of management, administrative, support and non-management employees that will be required to operate the business and indicate whether they will be employees of the ACDBE/DBE, non-ACDBE/DBE or joint venture:

	Non-ACDBE/DBE	ACDBE/DBE	Joint Venture
Management		1	1
Administrative	1		
Support	1		
Hourly Employees			8

JOINT VENTURE ELIGIBILITY FORM

General Information

Please provide the name of the person who will be responsible for hiring employees for the joint venture. **Muluje Hailemariam**

Who will they be employed by? **CI/EL-ROI, JV**

Are any of the proposed joint venture employees currently employees of any of the joint venture partners? **No**

Yes
()

No
(✓)

If yes, please list the number and positions and indicate which firm currently employs the individual(s), (use additional sheets if necessary)

Number of employees	Position	Employed By

Attached a copy of the proposed joint venture agreement, promissory note or loan agreement (if applicable), and any and all written agreements between the joint venture partners.

List all other business relationships between the joint venture participants, including other joint venture agreements in which the parties are jointly involved. **None.**

If there are any significant changes in or pertaining to this submittal, the joint venture members must immediately notify the Division of Small Business Opportunity.

JOINT VENTURE - ACDBE PORTION OF THE WORK

The Proposer: CI/EL-ROI, Jv

CI/EL-ROI, JV ("CI/EL") is committed to achieving a high level of meaningful DBE participation in all of its operations. CI/EL will meet the Airport's established goal for ACDBE participation with 40% projected participation. This level of ACDBE participation will be achieved through Muluye Hailemariam d/b/a El-Roi Fashion Jewelry ("EL-ROI") contribution as a 40% owner of CI/EL. More specifically, in addition to involvement with overall management of the joint venture's business, EL-ROI will have management responsibility and control of the day-to-day operations of CI/EL's locations.

In order to determine and establish responsibilities for EL-ROI which are commensurate with its 40% ownership interest in CI/EL, the parties have collectively created the Management Services Exhibit which is attached to CI/EL's joint venture agreement and included in this proposal. The Management Services Exhibit lists all of the services to be provided by both CI and EL-ROI and then assigns a corresponding "share of business effort" percentage. Consequently, when all of EL-ROI's services and corresponding "share of business effort" percentages are combined, EL-ROI's total "share of business effort" percentage equals 40%. The Management Services Exhibit, like the budget, is the foundation and basis for maintaining the appropriate allocation for both parties roles in CI/EL.

ACDBE's Contributions and Role

- I. Operations/Management: EL-ROI will provide the following management services:
- Hire and manage the General Manager responsible for day-to-day operations who serves as the on-site representative of CI/EL for airport officials, vendors and customers. EL-ROI will have the authority to both hire and 'fire' the General Manager, and through the General Manager to hire and 'fire' all associates and management personnel in the concession.
 - Conduct quarterly brand market surveys (conducted by the General Manager and Muluye Hailemariam, President of EL-ROI)
 - Perform all required operations for the pre-opening of the facility (conducted by the General Manager and Muluye Hailemariam).
 - Identify staffing needs, recruitment contacts, screening, and interviews (conducted by the General Manager and Muluye Hailemariam)
 - Select candidates for hire (conducted by the General Manager and Muluye Hailemariam, President of EL-ROI).
 - Ensure new hire documents are verified and processed properly (conducted by the General Manager, and Muluye Hailemariam).
 - Review and process personnel documents and maintain appropriate records (conducted by General Manager and Muluye Hailemariam)
 - Manage post offer screening and badging process (conducted by General Manager and Muluye Hailemariam).
 - Conduct orientation for all employees (conducted by the General Manager and Muluye Hailemariam).
 - Conduct any on-site training for employees (conducted by the General Manager and Muluye Hailemariam).
 - Conduct level 1 training within 30 days for new hire (customer service, cash handling, food safety and ServSafe/ Alcohol certifications (conducted by the General Manager and Muluye Hailemariam).
 - Order and distribute compliance postings for business units (conducted by the General Manager and Muluye Hailemariam).

In addition, with respect to all of the abovementioned services and in accordance with CI/EL's joint venture agreement, the EL-ROI Subcommittee will be established consisting of two (2) members to be appointed by EL-ROI and one (1) member to be appointed by CI. All decisions of the EL-ROI Subcommittee on the abovementioned matters will be by majority vote of the EL-ROI Subcommittee for which EL-ROI has majority vote.

Included below is a chart which illustrates the complete list of services to be provided by EL-ROI and by Concessions Denver, LLC (“CI-Denver”), the non-ACDBE joint venturer. Additionally, the chart establishes each joint venturers’ allocation of gross revenues through its respective business effort.

OPERATIONS 30% of the business effort EL-ROI	PRODUCT 10% of the business effort EL-ROI	ON-SITE ADMIN. SUPPORT 25% of the business effort CI-Denver	CORPORATE SUPPORT 35% of the business effort CI-Denver
Provide Operation General Manager responsible for day-to-day operations and who serves as the on-site representative of the Joint Venture for airport officials, vendors and customers.	Purchasing	Conduct semi-annual Safety, Quality Assurance and Purchasing Audits	Process accounts payables and accounts receivables. Process payroll.
Identify staffing needs, post position openings, establish recruitment contacts, and screen, interview and recommend candidates for hire.	Inventory Management	Provide Operations SOP's for implementation by General Manager and management team, including performance management system, kitchen and service SOP's, cash handling and service standards.	Administer benefits, compensation and bonus programs. Complete and submit required EEO-1 Reports.
Budget and monitor the financial performance of day to day operations.	Conduct quarterly Market Based Surveys per airport pricing policy.	Administer cash management functions.	Prepare Financial Statements and annual budget for approval by partners.
Ensure new hire documents are verified and processed properly.	Budget and monitor the performance of products.	Assist in the management of post-offer screening and badging process.	Coordinate annual gross receipts audit per airport and brand requirements.
Review and process documents and maintain appropriate records.	Decor/Display	Review incident reports, investigate & resolve GL, prop., crime claims.	Prepare and coordinate tax filings.
Manage post-offer screening and badging process.		Manage POS Fraud Prevention Program & POS Exception Reports.	Installation and support for IT equipment, email, network, security, polling, and POS PCI compliance.
Order and distribute compliance postings for business unit.		Manage OSHA Compliance (OSHA 300 Logs, etc.).	Management of construction for (i) pre-opening of the facility, (ii) annual repairs; and (iii) required refurbishments.
Day to day landlord relations.		Assist with day to day landlord relations.	Manage lease matters (financial and contractual, DBE, refurbishment, submission of reports)
Conduct w/in 30 days for new hires (Customer Service, Cash Handling, Food Safety and ServeSafe Alcohol/Tip Certification - mandatory for all employees).		Provide guidance and oversight for employee relations. Submit appropriate unemployment documentation & attend hearings.	Conduct/coordinate management 3 training (Cash Management, CPR/First Aid, Performance Management, ServeSafe/Food Safety Certification and Supervisory Skill; Loss Prevention & Safety and Purchasing Management)
Conduct orientation for all employees.		Manage WC & EPL claims in coordination w/ adjusters & attorneys.	Manage legal matters & coordinate outside counsel services. Administer license & permit applications & renewals.

II. Governance: CI/EL's overall management will be overseen by both CI and EL-ROI. For matters for which EL-ROI has control (listed above), EL-ROI will have majority voting rights (i.e. 2 votes versus 1 for the non-ACDBE company). For certain matters identified as 'Major Decisions' in the joint venture agreement (such as approval of the budget) unanimous agreement is required of both parties. CI and EL-ROI will continue to meet monthly to discuss the business of the company and to address items such as:

- how the unit is financially performing on a monthly basis compared to budget;
- personnel or operations concerns within the unit;
- customer service scores and identify any areas of concerns;
- create action plans with the general manager to address any financial, personnel, operation or service concerns and
- evaluate any potential future business opportunities.

EL-ROI has full input on financial decisions and new business opportunities. In addition, to the extent there is a new business opportunities, EL-ROI is expected to utilize all of its contacts and resources to add value to any proposal presented.

ATTACHMENT A
ACDBE Letter of Intent

Name of Company: CI/EL-ROI, JV

Address: 566 Wells Street, SW

City: Atlanta State: Georgia Zip: 30312

Telephone: 404-614-0300 E-mail address: ajoseph@cintl.com

Name of ACDBE Firm: Muluye Hailemariam d/b/a EL-ROI Jewelry

Address: 19877 E. 40th Avenue

City: Denver State: Colorado Zip: 80249

Telephone: 720-297-5671 E-mail address: Muluye12@msn.com

Description of Goods and Services or work to be performed by ACDBE firm:

See attached Exhibit A.

The Concessionaire is committed to utilizing the above named ACDBE for the goods and services or work described above. The estimated dollar value of this work is \$544,167.20.

AFFIRMATION:

The above-named ACDBE firm affirms that it will perform the portion of the contract for the estimated dollar value as stated above.

By:  Anthony Joseph Title
Concessionaire Signature

By:  MULUYE Muluye Hailemariam Title
ACDBE Signature

Exhibit "A" - Management Services

	Responsible Party		Share of Business Effort (%)	Cost Reimbursement Method*
	EL-ROI	CI		
1. Operations Procedures & Policies			5%	C
Provide Operations SOP's for implementation by General Manager and management team, including performance management system, kitchen and service SOP's, cash handling and service standards.	_____	_____ ✓		
2. Day-to-Day Operations & General Manager			22.5%	B
Provide Operation General Manager responsible for day-to-day operations and who serves as the on-site representative of the Joint Venture for airport officials, vendors and customers. <i>GM wages and benefits will be a reimbursable expense to the Joint Venture.</i>	_____ ✓	_____		
Conduct quarterly Market Based Surveys per airport pricing policy	_____ ✓	_____		
3. Pre-Opening Activities			5%	A
Perform all required operations for the pre-opening of the facility	_____ ✓	_____		
Management of construction for pre-opening of the facility.	_____	_____ ✓		
4. Construction Management			5%	A
Management of construction for (i) annual repairs; and (ii) required refurbishments.	_____	_____ ✓		
5. Product/Menu Development/Quality Assurance			7.5%	A
Conduct semi-annual Safety, Quality Assurance and Purchasing Audits	_____	_____ ✓		
6. Accounting/Payroll/Taxes			15%	B
Process payroll	_____	_____ ✓		
Prepare Financial Statements	_____	_____ ✓		
Process Accounts Payable and Accounts Receivable	_____	_____ ✓		
Coordinate annual gross receipts audit per airport & brand reqs.	_____	_____ ✓		
Prepare and coordinate tax filings	_____	_____ ✓		
Prepare annual budget for Management Committee approval	_____	_____ ✓		
Administer cash management functions	_____	_____ ✓		
7. Contracts & Legal Matters			2%	A
Manage lease matters (financial and contractual, DBE, refurbishment, submission of reports etc) with the landlord.	_____	_____ ✓		
Manage legal matters & coordinate outside counsel services	_____	_____ ✓		
Administer license & permit applications & renewals	_____	_____ ✓		
8. Information Technology			2.5%	B
Purchasing and Support of IT equipment including PC's, POS, laptops, printers, copiers, servers, routers and wireless devices.	_____	_____ ✓		
Installation and support for email, network, security, polling, and POS PCI compliance.	_____	_____ ✓		
9. HR - Recruitment & Staffing and On-Site Administration			10%	B
Identify staffing needs, post position openings, establish recruitment contacts, and screen, interview and recommend candidates for hire	_____ ✓	_____		
Ensure new hire docs. are verified and processed properly.	_____ ✓	_____		
Review and process documents and maintain appropriate records	_____ ✓	_____		
Manage post-offer screening & badging process	_____ ✓	_____		
Order and distribute compliance postings for business unit.	_____ ✓	_____		

Management Services (cont.)

	Responsible Party		Share of Business Effort (%)	
	EL-ROI	CI		
10. HR - On-Site Training			5%	B
Conduct orientation for all employees	✓	_____		
Conduct Level 1 training w/in 30 days for new hires (<i>Customer Service, Cash Handling, Food Safety and ServeSafe Alcohol/Tip Certification</i> • mandatory for all employees)	✓	_____		
11. HR - Corporate Training			5%	A
Conduct/coordinate Level 2 and Level 3 training (<i>Level 2 – Cash Management, CPR/First Aid, Performance Management, ServeSafe/Food Safety Certification and Supervisory Skills</i> • mandatory for all managers within first 6 months; <i>Level 3 – Civil Treatment for Managers, Loss Prevention & Safety and Purchasing Management</i> • mandatory for all managers within first year)	_____	_____		
Conduct train-the-trainer sessions for location management	_____	_____		
Coordinate on-the-job train-the-trainer program	_____	_____		
12. HR - Corporate Administration			7.5%	B
Provide guidance and oversight for employee relations	_____	_____		
Submit appropriate unemployment documentation & attend hearings	_____	_____		
Manage WC & EPL claims in coordination w/ adjusters & attorneys	_____	_____		
Administer benefits programs	_____	_____		
Administer compensation and bonus programs	_____	_____		
Complete and submit required EEO-1 Reports	_____	_____		
13. Loss Prevention			2.5%	A
Review incident reports, investigate & resolve GL, prop., crime claims	_____	_____		
Manage POS Fraud Prevention Program & POS Exception Reports	_____	_____		
Manage OSHA Compliance (OSHA 300 Logs, etc.)	_____	_____		
14. Business Development			2.5%	C
Manage landlord and community relations	_____	_____		
15. Brand Management			2.5%	C
Manage licensor relationship	_____	_____		
Partner Share of Management Services Responsibility:	40%	60%	100%	

* Cost Reimbursement Methods are as indicated on Exhibit B

EXHIBIT "B"

COST REIMBURSEMENT METHODS

Each Venturer is entitled to receive reimbursement from the Joint Venture for its costs incurred for services provided to the Joint Venture. Accordingly, the Venturers agree that the reimbursement of costs by the Joint Venture to the Venturers for each management service will be calculated based on one of the following methods ("**Cost Reimbursement Methods**").

The Cost Reimbursement Methods are as follows:

- A - Billed on an hourly basis. The Venturer providing the service will be reimbursed at a rate equivalent to its actual reasonable cost for the Venturer's employee providing the service.
- B - The salary of an employee will be allocated based on Percentage Time. For purposes of this Exhibit B, the term: (i) "**Percentage Time**" will be calculated by multiplying the total hours an employee works by the Allocation Percentage; and B "**Allocation Percentage**" will be calculated by dividing the total sales for a location by the total aggregate sales of all locations handled by such employee.
- C - No fee charged for services that constitute general governance and oversight.

One of the preceding Cost Reimbursement Methods is assigned to each management service listed on Exhibit "A". The Venturers may adjust the Cost Reimbursement Method for a particular service by unanimous agreement.



DENVER
THE MILE HIGH CITY

April 17, 2013

Anthony Joseph
Concessions International, LLC
566 Wells St
Atlanta, GA 30312

Muluye Hailermariam
El-Roi Fashion Jewelry
19877 E 40th Ave
Denver, CO 80249

Dear Mr. Joseph and Ms. Hailermariam,

The Division of Small Business Opportunity has reviewed the Joint Venture Application submitted by CI/EL-ROI JV and has approved your Joint Venture. This Joint Venture is approved specifically for operating the **Rocky Mountain Chocolate Factory (East), Concourse B, at Denver International Airport.**

We appreciate your interest in concessions opportunities at Denver International Airport. Should you have any questions concerning the approval process, please contact us at (303) 342-4358.

Sincerely,

Chris Martinez
Director, Division of Small Business Opportunity

Cc: Stacy Corbett, Business Management Services, DIA
Vicki Padilla, Division of Small Business Opportunity

Office of Economic Development
Division of Small Business Opportunity

201 W. Colfax Ave, Dept 907
Denver, CO 80202
p: 720.913.1999
f: 720.913.1809
www.milehigh.com

Denver International Airport
Airport Office Building, Suite 7810
8500 Peña Boulevard
Denver, CO 80249-6340
p: 303.342.2180
f: 303.342.2190
www.flydenver.com

EXHIBIT H

ABSOLUTE UNCONDITIONAL PERSONAL/CORPORATE GUARANTY

[REMOVED INTENTIONALLY]

EXHIBIT I
CONCESSION REVENUE MONTHLY REPORT

**DENVER
INTERNATIONAL
AIRPORT**

FOOD AND BEVERAGE CONCESSION REVENUE MONTHLY REPORT

For the month of: _____ (Mo. Year) Due on the 10TH DAY of the following month.

FROM: _____ Store name/location identifier: _____

(Company Name)

(Address)

Telephone # _____

Fax # _____

email _____

CUMULATIVE
REPORTABLE REVENUE
FROM PRIOR MONTH:

	FOOD	MERCHANDISE	ALCOHOL	
1. GROSS REVENUE	\$ _____	\$ _____	\$ _____	_____
2. REPORTABLE REV. THIS MO (Subtract Allowable Deduct	\$ _____	\$ _____	\$ _____	_____
3. PERCENTAGE COMPENSATION FEE				
Current Non-Alcohol Rate _____				
New Rate -when cumulative amt. reached _____				
Alcohol Rate _____				
TOTAL % COMPENSATION AMOUNT	\$ _____	\$ _____	\$ _____	_____
4. MINIMUM MONTHLY GUARANTEE	\$ _____			
5. PERCENTAGE AMOUNT DUE - line 3 less line 4	\$ _____			
6. 1% - JOINT MARKETING FUND (if applicable)	\$ _____			
7. TOTAL AMOUNT DUE WITH REPORT - line 5 + line 6	\$ _____			_____

CUMULATIVE
REPORTABLE REVENUE
GOING FORWARD:

REMIT AMOUNT ON LINE 7 WITH THIS REPORT IF LINE 7 IS GREATER THAN ZERO

NOTE: LINE 4 (MMG) IS DUE IN ADVANCE AND WITHOUT NOTICE ON THE 1ST DAY OF EVERY MONTH.

LATE PAYMENTS ARE ASSESSED INTEREST AND PENALTY CHARGES PER CONTRACT. LATE REPORTS ASSESSED \$100/DAY/REPORT.

MAKE CHECK PAYABLE TO: **AIRPORT REVENUE FUND**

Mail check to:

P.O. Box 492065

Denver, CO 80249-2065

OATH OF CONCESSIONAIRE:

The undersigned, being first duly sworn, deposes and says, that the gross revenues shown by this statement are true and just, and the percentage shown is due the City and County of Denver in accordance with the Concession Agreement.

(Please attach subtenants' concession revenue reports if there are any)

Signature

Authorized Officer

Date

EXHIBIT J
DIA ENVIRONMENTAL REQUIREMENTS

EXHIBIT J

DIA ENVIRONMENTAL REQUIREMENTS

SECTION 1: GENERAL REQUIREMENTS

In conducting any activity on Denver International Airport (“DIA”) property, Concessionaire shall comply with all applicable airport, local, state and federal rules, regulations, statutes, laws, and orders (“Environmental Requirements”). In addition, these Environmental Requirements include applicable Environmental Guidelines developed for DIA’s Environmental Management System (“EMS”), as summarized in DIA Rules and Regulations Part 180. DIA’s Environmental Guidelines, Environmental Policy, and all Rules and Regulations are available at www.flydenver.com. These Environmental Requirements address but are not limited to requirements regarding the storage, use and disposal of Hazardous Materials, solid and hazardous waste, or petroleum products; the National Environmental Policy Act (“NEPA”); and other federal, state, local water, wastewater, and air quality regulations.

A. EMS. DIA’s EMS has been certified to the ISO 14001 standard. DIA’s EMS includes the above-noted airport-wide Environmental Policy and is designed around the significant aspects identified in DIA Rule and Regulation 180. It is a requirement of the standard that all entities providing products, goods, and/or services on behalf of DIA ensure that their personnel are aware of DIA’s Environmental Policy, DIA’s significant environmental aspects, and the specific environmental aspects and associated impacts for the products, goods, and/or services that will be provided by Concessionaire.

B. Permits. Concessionaire shall acquire all necessary federal, state, local, and airport permits/approvals and comply with all permit/approval requirements. Concessionaire shall prepare and update all plans and provide all information required by the City for regulatory compliance purposes and provide copies of all permit applications and permits to DIA.

C. Hazardous Materials Limited. Any hazardous materials not normally used in Concessionaire’s operations are barred from DIA premises. Concessionaire shall identify all hazardous materials to be used at DIA along with a description of how these materials and any associated hazardous or other waste materials generated by Concessionaire will be managed while on airport property. This information is required prior to Concessionaire conducting activities on DIA property.

D. MSDSs. Prior to operation, Concessionaire shall maintain copies of Material Safety Data Sheets (“MSDSs”) for all chemicals to be used in their activities including those used for cleaning and maintenance. This obligation is continuing for the term of the Concession Agreement, and Concessionaire shall make this documentation available for DIA inspection upon request.

E. Pollution Prevention. Concessionaire is encouraged to utilize the concepts of pollution prevention, energy efficiency, and waste minimization with regard to its activities at DIA.

F. DIA’s recycling program. All plastics (#1-5, 7) along with metal food and beverage cans, glass jars and bottles, and paper goods (office papers and newspaper) will be recycled in the single-stream recycling infrastructure provided by DIA. Corrugated cardboard will be segregated and recycled in the cardboard compactors.

G. DIA's Composting Program. All food products along with waxy cardboard, paper napkins, paper towels, and compostable service-ware will be deposited into the composting infrastructure provided by DIA.

H. Green Procurement Process. Concessionaire will implement a green procurement process within their business and provide a copy of the green procurement process to DIA. All incoming products packaging shall be recyclable, compostable, or biodegradable to the greatest extent practicable.

SECTION 2: REVIEW OF ENVIRONMENTAL DOCUMENTS

At the City's request and upon reasonable notice and at reasonable times, Concessionaire shall make available for inspection and copying any or all of the documents and materials that Concessionaire has prepared pursuant to any Environmental Requirement hereunder or submitted to any governmental or regulatory agency. If there is a requirement to file any notice or report of a release or threatened release of a substance on, under, or about the work conducted on DIA property, Concessionaire shall provide a copy of such report or notice to the City.

SECTION 3: ACCESS FOR ENVIRONMENTAL INSPECTION

Without prior notice to Concessionaire, the City shall have an unimpeded right of access to and inspection of the occupancy or work areas in order to confirm that Concessionaire is conducting its activities in accordance with the Concession Agreement. At the City's request, Concessionaire shall conduct any testing and analysis at its cost. Such testing and analysis are necessary to ascertain whether Concessionaire is in compliance with the Concession Agreement.

SECTION 4: CORRECTION OF ENVIRONMENTAL NON-COMPLIANCE

If Concessionaire fails to comply with any applicable Environmental Requirement, at its election the City may enter the facility and/or work area and take such measures as may be necessary to ensure compliance with the Environmental Requirements. Concessionaire bears all the expenses taken by the City to correct Concessionaire's environmental non-compliance. The City's rights to correct such non-compliance are in addition to its rights and remedies described elsewhere in the Concession Agreement.

SECTION 5: DUTY TO NOTIFY THE CITY

Concessionaire shall immediately notify the City verbally by contacting the Airport Communications Center (303-342-4200) and the appropriate regulatory agency in the event of a release or threatened release of a substance relating to or arising out of Concessionaire's use or activities on DIA. Concessionaire also has a duty to notify the City in the event any claim, demand, cause of action, or notice is made against Concessionaire with regard to its failure or alleged failure to comply with any requirement hereunder. Concessionaire shall immediately control and remediate the contaminated media, and as provided below, Concessionaire shall follow-up its verbal notice with a written report within three days of such incident. In addition, at its expense Concessionaire shall provide the City with copies of any written claims, demands, notices, or actions so made.

SECTION 6: ENVIRONMENTAL REMEDIATION

Concessionaire shall undertake all actions necessary to remedy or remove any released or spilled materials and any other contamination discovered on or under DIA property introduced or affected by Concessionaire. At the City's sole discretion, Concessionaire shall restore the Concession Space to either its condition immediately prior to the initiation of the Concession Agreement or to a condition in compliance with all applicable local, state, federal, or airport laws, rules, regulations, or orders. This work shall be performed at Concessionaire's expense, and the City shall have the right to review the project plan, as well as review and inspect all such work at any time, using consultants and representatives of the City's choice. Concessionaire shall further conduct surface and subsurface monitoring pertaining to Concessionaire's activities hereunder to ensure compliance with applicable laws, rules, regulations, and permits or as determined by the Manager of Aviation.

SECTION 7: ENVIRONMENTAL REQUIREMENTS FOR CONSTRUCTION

Concessionaire agrees to ensure that its premises are designed, constructed, operated, and maintained in a manner that minimizes environmental impacts through application of appropriate preventive measures. Further, Concessionaire agrees to comply with all federal, state, and local environmental requirements. Concessionaire shall comply with the DIA Concessionaire Development Guidelines, as amended, for any alterations to existing facilities or the construction of any new facilities. In addition, Concessionaire shall comply with ***Exhibit X, Provisions of for Design and Construction of Improvements*** of the Concession Agreement.

EXHIBIT X

PROVISIONS FOR DESIGN AND CONSTRUCTION OF IMPROVEMENTS

EXHIBIT X

PROVISIONS FOR DESIGN AND CONSTRUCTION OF IMPROVEMENTS

GENERAL PROVISIONS

SECTION 1: GENERAL. Except as the context otherwise requires and unless otherwise expressly provided herein, the capitalized terms in this *Exhibit X* shall have the same meaning as any similarly capitalized terms defined in the Agreement or any exhibit thereto. Reference to Denver International Airport ("DIA"), Department of Aviation or Manager of Aviation shall mean that entity specifically, or that division or individual authorized to represent that entity. As used below the term "Concessionaire" or "Concessionaire" shall mean the "Party of the Second Part."

SECTION 2: COMPLIANCE WITH LAWS AND REGULATIONS

Concessionaire agrees to comply with and require its contractors to comply with all applicable federal, state, and local laws and all general rules and regulations applicable to construction at DIA, including payment of prevailing wages as defined in the Denver Revised Municipal Code Section 20-76. Additionally, Concessionaire agrees to pay all applicable sales and use taxes and to comply with Airport environmental controls and specifications, as well as the Americans with Disabilities Act, 42 USC 12,000 et seq. and its regulations.

In addition to the above, Concessionaire and its contractors shall comply with all DIA specific rules and regulations regarding site access, use of site, safety, security, design, and construction. Concessionaire and its contractors shall obtain and pay for all related permits. Failure to comply will be grounds for denial of access and/or suspension of construction activities. Regulations in force specific to DIA include but are not limited to the following:

The Denver Municipal Airport System Rules and Regulations

Tenant Design Guidelines; and

DIA Tenant Development Guidelines ("TDG")

SECTION 3: REQUIRED MINIMUM INVESTMENT

Concessionaire guarantees that it will make capital investments for its concession, construct the initial Improvements, and furnish and equip the Concession Space at a minimum investment set forth on the Summary Page ("Required Minimum Investment"). Such capital investments will be completed in strict conformity with the final plans and specifications marked "approved" by the City. The Required Minimum Investment shall not include financial costs, interest, inventory, pre-opening expenses, or intra-company charges but may include architectural and engineering fees not to exceed 15% of the total. The Required Minimum Investment is a material part of the consideration to the City under the Concession Agreement. Within 90 days after completing construction, Concessionaire shall file with the Manager lien releases for the above expenditures and a statement certified by its architect setting forth the total construction costs with appropriate detail itemizing design fees, original construction contract amount, total change orders, decorations, furnishings, fixtures, and equipment ("Actual Investment"). At the City's request, Concessionaire shall also submit copies of invoices supporting such costs. Non-receipted expenditures will not be credited. If the total amount of Concessionaire's Actual Investment is less than the Required Minimum Investment, Concessionaire shall pay to the City

the difference between such total cost (as detailed by the certified receipts) and the Required Minimum Investment within 30 days after the City provides written notice to Concessionaire. The Manager's Authorized Representative, however, will waive this requirement upon a finding that Concessionaire constructed the Improvements in strict conformity with the final plans and specifications as described above.

SECTION 4: IMPROVEMENTS. All Improvements and Concessionaire's Equipment must be of first-class quality, safe, attractive, in compliance with all applicable codes and the TDGs and may be installed only with the City's prior written approval. "Improvements," which may also be known as "Concession Improvements" or "Concessionaire Improvements," shall mean any new construction, equipment, finishes, fixtures, systems, furnishings, and furniture installed by Concessionaire, as well as modifications or alterations to existing construction, equipment, finishes, fixtures, systems, furnishings, and furniture which conform to drawings and specifications approved in writing by the Manager of Aviation. All items not affixed to Airport property subject to the Concession Agreement, including point of sale equipment, moveable furnishings, safes, racks, telephone equipment, non-affixed display fixtures, and other non-affixed personal property installed by Concessionaire and used in the operation of the business of Concessionaire (as distinguished from the use and operation of the Concession Space) shall be deemed to be "Concessionaire's Equipment." All items permanently affixed to the Concession Space shall be considered "Concessionaire Improvements."

DESIGN PROVISIONS

SECTION 5: DESIGN STANDARDS. First-class standards of design and construction are required, and all Improvements shall conform to applicable statutes, ordinances, building codes, and regulations; the DIA Design Standards; the TDGs as they may be amended from time to time; and any other applicable design, construction and maintenance standards. Approval of the Manager of Aviation shall extend to all design and construction elements (e.g., architectural, structural, mechanical, electrical, specialty systems, site, signage, materials, color selections, landscaping, and aesthetic matters). The City reserves the right to reject promptly any designs submitted and the right to require Concessionaire to resubmit designs and layout proposals until approved by the City. If the City disapproves any portion of the plans and specifications, Concessionaire shall promptly submit necessary modifications and revisions thereof. No substantial changes or alterations shall be made in said drawings or specifications after approval by the Manager of Aviation. Further, no alterations or improvements shall be made to or upon Concessionaire's site without prior City approval.

SECTION 6: DESIGN PERIOD. All improvements to be made to or upon the Concession Space by Concessionaire are subject to the prior written approval of the Manager or the Manager's Authorized Representative. Concessionaire shall coordinate its design with the City. Unless otherwise instructed, Concessionaire shall submit its preliminary plans for approval no later than the Preliminary Design Due Date as stated on the Summary Page in order to ensure prompt commencement of construction and completion by the Required Opening Date.

SECTION 7: DESIGN PROCEDURES. Manual 1 of the TDGs and the Concessionaire Development Standards govern the procedures and requirements regarding design, including design process and schedule, submittal requirements, review and approval process, design modifications, and project coordination. As soon as practical, Concessionaire shall attend a pre-design meeting with the Airport's concessions management team. Thereafter, on or before the Preliminary Design Due Date, Concessionaire shall prepare and submit for the City's review the preliminary design package ("DRC Package"). The DRC Package consists of three (3) photo quality renderings that clearly depict the proposed design concept in context with the surrounding area. The renderings depict the space approximately six feet (6') beyond the demising walls and include merchandising on the shelves and people in the space. In addition, one material sample board, floor plan, and reflected ceiling plan are necessary to provide a complete understanding of the space. An electronic copy of the fully complete plans and specifications for all work, facilities, improvements, and a schedule of the time required to complete same shall be submitted to the Designated Project Manager for review and written approval. A copy of the plans and specifications shall be separately submitted to the City's Building Inspection Division and Fire Department. Prior to submission of DRC Package, Concessionaire should carefully review the Tenant Design Guidelines and DIA Concession Design Standards. The City reserves the right to promptly reject any submission that is not in material compliance with the foregoing.

The City shall have two weeks to review and return comments or approve the DRC Package and notify Concessionaire of such approval. Any additional time taken by the City in excess of the two week DRC Package approval time shall be added to certain dates as provided in Section 6.02 of the Concession Agreement. The City shall have two weeks to review each DRC Package submitted or resubmitted by Concessionaire..

Once DRC Package is approved, Concessionaire may move forward with the design for the Concession Space in accordance with the TDGs. The design shall include all Concessionaire finish requirements, including lighting, power, plumbing, HVAC distribution from the main air supply, HVAC controls for the tie in to the base building system, supplemental HVAC if needed, life safety systems, interior finishes, all furnishings, fixtures, trade fixtures, equipment, and signage necessary to operate in a first-class manner. Special attention must be given to the design of the HVAC and electrical systems. For a concept that creates odors, the mechanical system must be designed or configured to prevent the transmission of said odors to other portions of the Concourses or the Terminal. All plans and specifications, materials, and color selections are subject to review and approval by the Manager's Authorized Representative.

Concessionaire shall prepare for City approval final plans and detailed specifications that incorporate the design intent approved by the City in the DRC Package ("Final Plans"). Final Plans must be prepared by an architect or engineer licensed to practice in the State of Colorado. All design and construction drawings submitted by Concessionaire to DIA shall be provided in the latest release of AutoCAD format in accordance with the DIA's Design Standards Manual.

In addition to the above, Concessionaire is responsible for coordinating with the Denver Building Inspection Division, Zoning, Fire Department, Wastewater Management, Consumer Protection, and Health and Hospitals, etc. as may be required to comply with submittal, review, and approval requirements in order to obtain all required permits. Prior to the NTP Document Deadline, Concessionaire or contractor shall deliver to the Manager of Aviation copies of all

required permits, licenses, and all other documents as required by Manual 1 of the DIA Concessionaire Development Guidelines.

As soon as practicable but no later than 10 days after approval by the City of the Concessionaire's Final Plans, Concessionaire shall attend a pre-construction meeting with the Airport representatives, including but not limited to the Designated Project Manager. Concessionaire may not construct or install the initial Improvements without City approved Final Plans and a City issued Notice to Proceed ("NTP"). Before beginning any construction work on the Concession Space, Concessionaire must obtain at Concessionaire's expense, a NTP as described in the Concessionaire Development Guidelines. Prior to the issuance of an NTP, Concessionaire shall obtain and pay for all approvals, licenses, and permits required for the Improvements. Whenever a conflict arises between state or local law, ordinances or regulations, and federal law or regulations, the most stringent law or regulations applicable to the Concession Agreement shall control.

Prior to the NTP Document Deadline, Concessionaire shall submit the NTP Documents, a list of which is provided below, to DIA. A detailed description of all the requirements can be found in the Tenant Development Guidelines.

The required NTP Documents are as follows:

1. An electronic copy of the Approved drawings and specifications;
2. Either an electronic or hard copy of the construction contract;
3. A sworn statement listing contractors and subcontractors at all tiers, a description of work and the contract amounts, and approval from the Auditor's Office that the documents are acceptable;
4. An electronic copy of the fully executed concession agreement between DIA and Concessionaire;
5. An electronic copy of contractor's insurance documentation as set forth in TDGs, Volume 3, Appendix B;
6. Contractor's original Performance Bond, Payment Bond, and dual obligee rider on the DIA approved form;
7. Original Concessionaire Payment Bond on the DIA approved form;
8. An electronic copy of the Building Permit;
9. An electronic copy of the detailed bar chart schedule of construction;
10. An electronic copy of all CADD and Word file construction documents;
11. An electronic copy of the contractor's safety plan;
12. An electronic copy of the DSBO/ MOCC/ SBOD forms and an approval from them indicating that the minimum required participation has been met;

13. An electronic copy of the contractor's acceptance; and
14. A sworn statement from Concessionaire certifying that the contractor has submitted their qualifications. Concessionaire certifies that it has investigated the qualifications of its proposed subcontractors and has identified the existence of any of the following items or certified to the best of their knowledge and belief that the problems listed below do not exist:
 - a. Default on a contract within the last 3 years;
 - b. Default on a contract which required that a surety complete the contract under payment or performance bonds issued by the surety;
 - c. Debarment within the last 5 years by a public entity or any organization which has formal debarment proceedings;
 - d. Significant or repeated violations of federal Occupational Safety and Health Act ("OSHA") safety requirements ;
 - e. Failure to have the required City or Colorado licenses to perform the work described in the contract; and
 - f. Conviction within the last 5 years by the contractor, its principal owners, or its officers of an offense involving fraud or racketeering.

The City reserves the right to promptly reject any submission that is not in material compliance with the TDGs.

The City shall have two weeks to review and return comments or approve the NTP Documents and notify Concessionaire of the approval by issuing the NTP. Any additional time taken by the City in excess of the two week NTP Document approval time shall be added to certain dates as provided in Section 6.02 of the Concession Agreement. The City shall have two weeks to review each set of NTP Document submitted or resubmitted by Concessionaire.

Concessionaire's contractor shall maintain in effect throughout the construction period, a construction performance and payment bond in a sum not less than 100% of the construction contract price. Said bond shall guarantee prompt and faithful performance of the contract and prompt payment by Concessionaire to its contractors and by Concessionaire's contractors to all persons supplying labor, materials, team hire, sustenance, provisions, provender, supplies, rental machinery, tools, and equipment used directly or indirectly by the said contractor, subcontractor(s), and suppliers in the prosecution of the work provided for in said construction contract. Said bonds shall also protect the City from any liability, losses, or damages arising therefrom.

CONSTRUCTION PROVISIONS

SECTION 8: STANDARD OF PERFORMANCE. All work done by Concessionaire or its contractors shall be done in a first-class workmanlike manner using only good grades of materials and shall comply with all insurance requirements; all applicable laws and ordinances, and all rules and regulations of governmental departments or agencies. Whenever a conflict

arises between state or local law, ordinances or regulations, and Federal law or regulations, Federal law or regulations applicable to the Concession Agreement shall control.

SECTION 9: CONSTRUCTION DEADLINE. Concessionaire shall construct the Concession Improvements on or before the Required Opening Date. The Required Opening Date may be extended by the Manager if completion of the Concession Improvements was delayed by fault of the Airport, in which case, the Parties will proceed to document the changed dates on ***Exhibit D, Confirmation of Actual Dates and Term***, as provided in Section 6.02.

After an NTP is issued by the City, Concessionaire shall construct and install all initial Improvements necessary for the customary operation of Concessionaire's business, including, but not limited to, lighting, power, plumbing, HVAC distribution from main air supply, HVAC controls for the tie in to the base building system, supplemental HVAC if needed, life safety systems, interior finishes, all furnishings, fixtures, trade fixtures, equipment, signage, counters, display cabinets, interior partitions, lighting, fixtures, wall and ceiling finishes, flooring and floor coverings, furniture, furnishings, trade fixtures, signage, and all other equipment and furnishings necessary to operate in a first-class manner.

All construction performed by Concessionaire, including construction and installation of all Improvements, shall conform in all material respects to the Final Plans, DIA Tenant Development Guidelines, applicable statutes, ordinances, building codes, fire codes, state and federal OSHA safety requirements, Airport Rules and Regulations, the City's Concessionaire construction permit requirements, the requirements of ***Exhibit X, Provisions for Design and Construction of Improvements***, and the Americans with Disabilities Act ("ADA") requirements.

SECTION 10: COORDINATION OF CONSTRUCTION. Concessionaire shall cooperate with the City and its planners, designers, architects, and engineers in the construction and installation of the Improvements on the Concession Space, and Concessionaire shall comply with all approved plans and the Building Code. Concessionaire agrees to meet with the City on a periodic basis as requested by the Airport. The Airport Concessions Manager shall be copied on all design and construction meeting minutes. Concessionaire recognizes that during the Term (or any extended term) of the Concession Agreement, construction may also occur in adjacent areas surrounding its Concession Space, and Concessionaire agrees to cooperate with and grant to other contractors access to its Concession Space when necessary to accommodate construction occurring in adjacent areas.

SECTION 11: CONSTRUCTION PROCEDURES. Refer to Manual 1 of the DIA Concessionaire Development Guidelines for procedures and requirements regarding construction, including but not limited to construction schedule, submittal requirements, review and approval process, construction inspections, construction modifications, and project coordination.

Compliance with Standards. All construction work shall comply with the requirements of and standards established by the City and all other appropriate governmental agencies and entities. The City shall at all times have the right to monitor and inspect any construction to assure that the Improvements are constructed and installed in full compliance with the plans and specifications.

Work Subject to Inspection. All construction work, materials, and installations involved in or incidental to the construction on the Concession Space shall be subject at all times to inspection

and regulatory control by the City. In the performance of construction activities for Improvements, Concessionaire is responsible for compliance and shall require its contractors to comply with all federal, state, and local environmental requirements including, without limitation the Environmental Requirements set forth on ***Exhibit J, DIA Environmental Requirements***.

Safety During Construction. DIA shall have the right to halt construction of the Improvements or deny access to the site at any time if construction is at material variance from the approved drawings and specifications until such variance is corrected. Similarly, if such construction poses an immediate safety hazard at the Airport, DIA has the right to halt construction until such safety hazard is eliminated. The City shall cooperate and use its best efforts to alleviate and resolve any such variance or impediment to the safe operation of the Airport so as to permit continued construction as expeditiously as possible.

Submittal of Necessary Information. In order to assist DIA in monitoring and inspecting construction, Concessionaire shall submit or cause to be submitted for information and record copies of all field test reports, certificates of insurance, waivers of liens, material certificates, shop drawings, and submittals for review for compliance with DIA design and construction standards, contractor application for payment requests, construction progress reports, notification of substantial completion of Improvements and final acceptance, two copies of maintenance and operation manuals in connection with building systems and all updates thereof, as-built documents, and any other documents related to the construction of the Improvements which may be reasonably requested by DIA.

Change Orders Require Prior Approval. The Building Inspection Division of the City and County of Denver and DIA shall receive copies of all change orders. No change order or other contract modification that materially changes the scope of the Improvements shall be executed without prior approval of the Manager of Aviation, whose approval shall not be unreasonably withheld. The City will approve, conditionally approve, or disapprove submissions of change orders that materially change the scope of the work within a reasonable period of time following receipt thereof. Any conditional approval or disapproval shall be accompanied by a detailed explanation as to the reason for the condition.

Responsibility for Temporary Utilities. Concessionaire is responsible for all temporary utilities required during construction. At its sole cost and expense, Concessionaire shall obtain and make utility connections, hook-ups, or taps as necessary or as stipulated in the Concession Agreement, securing all necessary applications or permits and paying all associated fees. At its sole cost and expense, Concessionaire shall provide meters calibrated by the utility company and maintain equipment as required to provide accurate measurement of usage and consumption. DIA makes no warranty as to the location of structures, wiring, fixtures or systems, and Concessionaire accepts them on an "as is" basis without further recourse against DIA as to their location, number, or suitability for Concessionaire's particular purposes.

Maintenance of Safe Construction Site. Concessionaire is responsible for maintaining a clean, orderly, and safe construction site, free of accumulated construction debris and waste materials, and Concessionaire shall be responsible for legal removal of same. Construction shall be accomplished without interfering with travelers, airport operations, or other businesses, providing barricades, and/or construction enclosures as required.

Completion of Construction. Upon completion of construction of the initial Improvements, Concessionaire shall deliver to the City a copy of the Temporary Certificate of Occupancy

("TCO") and Certificate of Occupancy ("CO") for the entire (100%) Concession Space if one is issued by the City Building Department. If a TCO or CO is not issued by the City Building Department, Concessionaire shall provide a copy of the final Permit Inspection Card indicating inspection and approval by the issuer of said permit. Concessionaire shall obtain the City's written permission to remove its construction wall and shall immediately thereafter Open for Business and document the Rent Commencement Date as provided in Section 4.03.

Lien Releases and Other Documents. Within 60 days after the earlier of (a) completion of construction of the initial Improvements or (b) Rent Commencement Date, Concessionaire shall deliver to the City original executed copies of all mechanics' lien releases or other lien releases notarized and unconditional in such form as the City shall have approved and an architect's certification that the Improvements have been constructed in strict accordance with the approved Final Plans and are fully complete in accordance with this **Exhibit X**. Upon the City's request, Concessionaire agrees that Concessionaire will jointly inspect the Concession Space with the City to verify as-built drawings.

PROVISIONS FOR SIGNS AND WINDOW DISPLAYS

SECTION 12: UNIFORM STANDARDS. Concessionaire understands and agrees that the City has established criteria so that all signs conform to certain uniform standards and criteria and that those criteria are set out in the DIA Design Standards and the DIA Tenant Development Guidelines. The City shall have the right in its sole discretion to prohibit any sign proposed by Concessionaire. Concessionaire will not place or suffer to be placed or maintained on any exterior door, wall or window of the Concession Space any sign, awning or canopy, or advertising matter or other thing of any kind, and will not place or maintain any exterior lighting, plumbing fixture or protruding object or any decoration, lettering or advertising matter on the glass of any window or door of the Concession Space without first obtaining the City's written approval and consent. At Concessionaire's sole cost and expense, upon demand by the Manager's Authorized Representative, Concessionaire shall immediately remove any sign installed in violation of the foregoing provisions. At Concessionaire's sole cost and expense, Concessionaire shall return the site of such sign to its condition prior to the placement or erection of the sign. Concessionaire further agrees to maintain such sign, awning, canopy, decoration, lettering, advertising matter, or other thing as may be approved in good condition and repair at all times. At the expiration or earlier termination of the Concession Agreement, Concessionaire shall remove its signage and repair all damage to the Concession Space caused by such removal.

SECTION 13: STOREFRONT SIGNAGE. Concessionaire shall affix a sign to the exterior surface of the storefront of the Concession Space, subject to the advance approval of and field inspection by the Manager or the Manager's Authorized Representative. Concessionaire shall pay all costs of fabricating, constructing, operating, and maintaining such sign including, without limitation, all charges for electricity. Concessionaire shall keep said sign well lit during such hours as the Manager's Authorized Representative shall designate.

SECTION 14: INTERIOR SIGNAGE. At Concessionaire's sole cost and expense, the City will permit Concessionaire to install and operate signs in the Concession Space that are professionally fabricated and/or printed, subject to written approval by the City.

Concessionaire shall request the City's approval by submitting a written request, accompanied by a detailed rendering or drawing of the proposed sign and the proposed location. All signs

located in the interior of the Concession Space shall be in good taste so as not to detract from the general appearance of the Concession Space or the Airport. No symbol, design, name, mark, or insignia adopted by the City for the Airport shall be used without the prior written consent of the City.

Under no circumstances shall any handwritten or temporary signs or displays be posted or used by Concessionaire, including but not limited to any price lists or employment opportunity signs in the Concession Space. Concessionaire may place decals relating to credit or charge cards accepted on storefronts where warranted, subject to the prior written approval of the Manager's Authorized Representative with respect to size, design, and placement.

Without the City's prior written approval, Concessionaire shall not install, have installed, or allow to be installed upon or within the Concession Space any sign whether lighted or unlighted (except for specialty retail merchandise and items boards) poster or other display of advertising media including material supplied by manufacturers of merchandise offered for sale; or other types of display specified in the DIA Design Standards. Permission will not be granted for any advertising which fails to comply with DIA Design Standards or DIA Development Guidelines, or any advertising material, fixture, or equipment that extends beyond the Concession Space.

MODIFICATIONS AND ALTERATIONS

SECTION 15: MODIFICATIONS AND ALTERATIONS. After construction and installation of the initial Improvements, Concessionaire agrees not to materially improve, change, alter, add to, remove, or demolish any part of the Improvements without the prior written consent of the Manager or the Manager's Authorized Representative. Subsequent construction work occurring during the Term (or any extended term) of the Concession Agreement, shall be subject to the prior written approval of the City. If required, such construction work may require an NTP if so determined by the City. Such construction work includes all repairs in excess of \$15,000.00, renovations, and remodeling. Modifications and alterations to existing Concessionaire improvements are subject to the same requirements, including but not limited to prevailing wage, and provisions as new Concessionaire improvements as itemized in this **Exhibit X**. The Concession Agreement and Concessionaire must comply with all conditions which may be imposed by and in the Manager's sole discretion.

Advance Notice of Modification. Concessionaire shall give or cause to be given to the City advance notice before performing any material modification to the improvements.

Expense of Alterations. Any work necessary to make any alterations, improvements, or additions to the facility throughout the term of the Concession Agreement shall be done at Concessionaire's cost and expense in accordance with and subject to all of the required approvals, submittals, procedures, and all other requirements of whatsoever nature, as set forth herein.

Subsequent Work. If subsequent work is approved, the same process outlined above for the City's approval of the work shall be followed unless otherwise directed by the City. Concessionaire must comply with all conditions imposed by the Manager's Authorized Representative in the representative's judgment and all required approvals, submittals, and procedures of whatsoever nature, as set forth in the City's approval. Any work necessary to make alterations, improvements, or additions to the Concession Space throughout the Term (or

any extended term) of the Concession Agreement shall be done at Concessionaire's cost and expense.

Revised Drawings, Final Waivers to be Provided. Upon completion of subsequent construction work, Concessionaire shall deliver to the City revised as-constructed drawings, evidence of payment, contractor's affidavits, and full and final waivers of any liens for labor, services, or materials. Concessionaire shall include in its agreement with its contractors provisions whereby such contractors shall defend and hold the City harmless from all costs, damages, liens, and expenses related to such work.

Removal and Demolition of Improvements. Concessionaire shall not replace, remove, or demolish in whole or in part any Concessionaire Improvement on the Concession Space during the Term (or any extended term) of the Concession Agreement without the prior written approval of the Manager's Authorized Representative. In his/her sole discretion, the Manager's Authorized Representative may condition such approval upon the obligation of Concessionaire to replace the Improvement with a comparable improvement specified by the Manager's Authorized Representative.

The City May Demand Removal or Satisfactory Changes. In the event that any construction, improvement, alteration, modification, addition, repair (excluding emergency repairs), or replacement is made without the prior written consent of the Manager's Authorized Representative or made in a different manner than approved, the City may terminate the Concession Agreement in accordance with the provisions for termination herein. Alternatively, upon notice to do so, Concessionaire will remove the same, or at its discretion, Concessionaire shall cause the same to be changed to the satisfaction of the City. In case of any failure on the part of Concessionaire to comply with the notice, in addition to any other remedies available to it, the City may effect the removal or change referenced above in this Section and Concessionaire shall pay the cost thereof to the City upon demand.

SECTION 16: AS-BUILT DOCUMENTS. No later than 60 days after completing all work for the Improvements, Concessionaire shall provide DIA one complete electronic set of as-built documents prepared in accordance with DIA requirements. If Concessionaire fails to provide as-built documents after written notice from DIA, DIA may elect to have the documents completed and charge Concessionaire for the costs associated therewith. Upon DIA's request, Concessionaire agrees that Concessionaire will inspect the Improvements jointly with DIA to verify as-built documents.

MISCELLANEOUS PROVISIONS

SECTION 17: PAYMENT OF PREVAILING WAGE RATES. Concessionaire shall require its contractor and all of its subcontractors to pay every worker, laborer, or mechanic employed by them in the performance of the construction of the Improvements prevailing wages, including fringe benefits or their cash equivalent, for the same class and kind of work in the City and County of Denver, as determined by the Career Service Board under the provisions of Section 20-76 of the Denver Revised Municipal Code ("D.R.M.C."). The wages shall be those prevailing at the time of the contractor's final bid, and Concessionaire shall require the contractor to submit with its bid the applicable wage schedule. The contractor shall post in a prominent and easily accessible place at the site of the Improvements the scale of wages to be paid by the contractor and all subcontractors at any tier working under the contractor. During each week of work progress, the contractor shall furnish to the Mayor's Office of Contract Compliance and to the

Auditor or the Auditor's authorized representative a true and correct copy of the payroll records of all workers employed to perform the work. All payroll records shall include information showing the number of hours worked by each worker, the hourly pay of such worker, any deductions made from pay, and the net amount of pay received by such worker for the period covered by the payroll. The payroll record shall be accompanied by a sworn statement of the contractor that the copy is a true and correct copy of the payroll records of all workers performing the work whether for the contractors or subcontractors that payments were made to the workers as set forth in the payroll records, that no deductions were made other than those set forth in such records, and that all workers were paid the prevailing wages as of the contractor's final bid for the work. Compliance with above requirements shall be deemed a work "specification" as such word is used in Section 5-18(d), D.R.M.C. Violation of the prevailing wage requirement and its documentation, hereinabove set forth, shall result in an order from the Manager of Aviation for the work to cease until there is satisfactory evidence that the violation has been remedied and will not reoccur. The issuance of a stop-work order shall not relieve contractor's surety of any liability on contractor's bond or bonds, but such a stop-work order shall be deemed a default by the contractor insofar as said surety's obligation is concerned.

SECTION 18: SBE, DBE, AND MBE/WBE PARTICIPATION. The Concession Agreement is subject to the requirements of Articles III and VII of the Denver Revised Municipal Code.

Concessionaire agrees that it shall provide for participation of Small Business Enterprises (SBEs) in the design and construction of Improvements, in compliance with Article VII, Division 1 of Chapter 28, D.R.M.C., or any successor ordinance effective at the time of any design and construction that Concessionaire may carry out during the life of the Concession Agreement. An estimation of the goal for the percentage of design and construction work to be performed by SBE firms is set forth below. Concessionaire shall make a good faith effort to meet said estimated goals or a goal set by the goals committee. The decision to use the estimated goals or to send the contract to the goals committee shall be made by the Director of DSBO. Further, the City and County of Denver encourages Concessionaires to utilize SBEs and to divide the design and construction work into economically feasible units or segments to allow the most opportunity for subcontracting.

SBE DESIGN AND CONSTRUCTION GOALS:

- \$ 0 < \$30,000 = 0%
- \$30,000 - \$90,000 = 3%
- \$90,000 < \$150,000 = 5%
- > \$150,000 = Goals Committee

Concessionaire agrees that it shall provide for participation of Disadvantaged Business Enterprises (DBEs) in the design and construction of the Concession Improvements. After the Concession Agreement is executed, Concessionaire agrees to use its best efforts to utilize qualified and available DBE firms which have been and which continue to be certified by the City to the fullest extent which is reasonably possible to achieve. The goal for percentage of design and construction work performed by DBE firms is specified on the Summary Page, and in accordance with 49 U.S.C. 2210(h)(2)(1992) Concessionaire shall make a good faith effort to meet such goal as part of its overall DBE obligation.

Concessionaire agrees that it shall provide for participation of Minority Business Enterprises ("MBE") and Women Business Enterprises ("WBE") in the design and construction of Improvements, in compliance with the requirements of Article III, Divisions 1 and 3 of Chapter

28, of the Denver Revised Municipal Code (“MBE/WBE Ordinance”), or applicable successor ordinance, during the life of the Concession Agreement. Concessionaire agrees to comply with rules and regulations issued by the Director of the Division of Small Business Opportunity (“DSBO”), a division of the Mayor’s Office of Economic Development. The goal for percentage of design and construction work to be performed by MBE/WBE firms is set forth on the Summary Page, and Concessionaire shall meet, or make a good faith effort to meet, such goals as have been set in accordance with the ordinance. Further, the City and County of Denver encourages Concessionaires to utilize MBE/WBE firms and to divide the design and construction work into economically feasible units or segments to allow the most opportunity for subcontracting.

SECTION 19: INSURANCE REQUIREMENTS. Concessionaire shall comply with the insurance requirements set forth on the Summary Page and Appendix B of Manual 1 of the TDGs for insurance requirements for Concessionaire, Concessionaire's Design Consultants, and Concessionaire's Contractors concerning insurance coverage for design and construction of Improvements and completed Improvements, including requirements for submittal of certificates and renewals of insurance.

SECTION 20: EVIDENCE OF INSURANCE. Certified copies of required insurance policies, or certificates, in the standard form required, evidencing the existence thereof, or binders, shall be delivered to the DIA Division of Planning and Development at least 15 days prior to the commencement of any design work to be performed by Concessionaire's consultants and any construction work for Improvements. If a binder is delivered, it shall be replaced within 30 days by a certified copy of the policy or the required certificate. Policies shall be in a form and of a company acceptable to and approved by the City, and certificates shall be on standard City and County of Denver Certificate of Insurance forms.

Each such policy or certificate shall contain a valid provision or endorsement that the policy may not be canceled, terminated, changed or modified without 45 days prior written notice (10 days for nonpayment of premium) given by certified mail, return receipt requested, to the Manager of Aviation, 8500 Peña Boulevard, Denver, Colorado 80249-6340.

Each such policy or certificate shall further provide that any coverage afforded the City and County of Denver as an additional insured under the policy shall apply as primary insurance and any other insurance issued to the City and County of Denver shall apply as excess and noncontributing insurance.

Any renewal certificate shall be delivered to the Manager of Aviation at least 10 days prior to the expiration of each expiring policy. If at any time any of the insurance policies shall be or become unsatisfactory to the Manager of Aviation as to form or substance, or if any of the carriers issuing such policies shall be or become unsatisfactory to the Manager of Aviation, Concessionaire shall promptly obtain a new and satisfactory replacement policy.

SECTION 21: LIMITATION ON LIABILITY. Concessionaire agrees that no liability shall attach to the City for any damages or losses incurred or claimed by Concessionaire or any other person or party on account of the construction or installation of the Improvements or other Improvements to the Concessionaire's site made by the Concessionaire. Concessionaire agrees that no liability shall attach to the City for any interference or delay caused by construction in adjacent areas, travelers, other businesses or airport operations, including without limitation, damages or losses in the nature of delay damages, lost labor productivity, and

impact damages. Concessionaire agrees to indemnify, defend and hold harmless the City from any loss, cost, damage or expense incurred, claimed, asserted or arising in connection with Concessionaire's or its contractors' or agents', construction or installation of the Improvements or other Improvements to the site made by the Concessionaire.

APPENDIX NO. 1

STANDARD FEDERAL ASSURANCES AND NONDISCRIMINATION

NOTE: As used below the term "contractor" shall mean and include the Concessionaire, and the term "sponsor" shall mean the "City."

During the term of this contract, the contractor, for itself, its assignees and successors in interest (hereinafter referred to as the "contractor") agrees as follows:

1. Compliance with Regulations. The contractor shall comply with the Regulations relative to nondiscrimination in federally assisted programs of the Department of Transportation (hereinafter "DOT") Title 49, Code of Federal Regulations, Part 21, and Title 14, CFR, Part 152, Subpart E, as they may be amended from time to time (hereinafter referred to as the Regulations), which are herein incorporated by reference and made a part of this contract.

2. Nondiscrimination. The contractor, with regard to the work performed by it during the contract, shall not discriminate on the grounds of race, creed, color, national origin, or sex in the selection and retention of subcontractors, including procurements of materials and leases of equipment. The contractor shall not participate either directly or indirectly in the discrimination prohibited by Title 49, Section 21.5 of the Regulations, including employment practices when the contract covers a program set forth in Appendix B of the Regulations.

3. Solicitations for Subcontractors, Including Procurements of Materials and Equipment. In all solicitations either by competitive bidding or negotiation made by the contractor for work to be performed under a subcontract, including procurements of materials or leases of equipment, each potential subcontractor or supplier shall be notified by the contractor of the contractor's obligations under this contract and the Regulations relative to nondiscrimination on the grounds of race, color, or national origin.

4. Information and Reports. The contractor shall provide all information and reports required by the Regulations or directives issued pursuant thereto and shall permit access to its books, records, accounts other sources of information, and its facilities as may be determined by the sponsor or the Federal Aviation Administration (FAA) to be pertinent to ascertain compliance with such Regulations, orders, and instructions. Where any information required of a contractor is in the exclusive possession of another who fails or refuses to furnish this information, the contractor shall so certify to the sponsor of the FAA, as appropriate, and shall set forth what efforts it has made to obtain the information.

5. Sanctions for Noncompliance. In the event of the contractor's noncompliance with the nondiscrimination provisions of this contract, the sponsor shall impose such contract sanctions as it or the FAA may determine to be appropriate, including, but not limited to:

- a. Withholding of payments to the contractor under the contract until the contractor complies, and/or
- b. Cancellation, termination, or suspension of the contract, in whole or in part.

6. Incorporation of Provisions. The contractor shall include the provisions of paragraphs 1 through 5 in every subcontract, including procurements of materials and leases of equipment, unless exempt by the Regulations or directives issued pursuant thereto. The

contractor shall take such action with respect to any subcontract or procurement as the sponsor or the FAA may direct as a means of enforcing such provisions including sanctions for noncompliance. Provided, however, that in the event a contractor becomes involved in, or is threatened with, litigation with a subcontractor or supplier as a result of such direction, the contractor may request the sponsor to enter into such litigation to protect the interests of the sponsor and, in addition, the contractor may request the United States to enter into such litigation to protect the interests of the United States.

7. Covenant Runs With the Land. The Concessionaire for itself, representatives, successors in interest, and assigns, as a part of the consideration hereof, does hereby covenant and agree as a covenant running with the land that in the event facilities are constructed, maintained, or otherwise operated on the said property described in this agreement for a purpose for which a DOT program or activity is extended or for another purpose involving the provision of similar services or benefits, the Concessionaire shall maintain and operate such facilities and services in compliance with all other requirements imposed pursuant to 49 CFR Part 21, Nondiscrimination in Federally Assisted Programs of the Department of Transportation, and as said Regulations may be amended.

8. Non-Discrimination in Use. The Concessionaire for itself, representatives, successors in interest, and assigns, as a part of the consideration hereof, does hereby covenant and agree as a covenant running with the land: (1) that no person on the grounds of race, color, sex, creed or national origin shall be excluded from participation in, denied the benefits of, or be otherwise subjected to discrimination in the use of said facilities, (2) that in the construction of any improvements on, over, or under such land and the furnishing of services thereon, no person on the grounds of race, color, sex, creed or national origin shall be excluded from participation in, denied the benefits of, or otherwise be subjected to discrimination, (3) that the Concessionaire shall use the premises in compliance with all other requirements imposed by or pursuant to 49 CFR Part 21, Nondiscrimination in Federally Assisted Programs of the Department of Transportation, and as said Regulations may be amended.

9. Nondiscrimination in Airport Employment Opportunities. The Concessionaire assures that it will comply with pertinent statutes, Executive Orders and such rules as are promulgated to assure that no person shall, on the grounds of race, creed, color, national origin, sex, age, or handicap be excluded from participating in any activity conducted with or benefiting from Federal assistance.

It is unlawful for airport operators and their lessees, tenants, concessionaires and contractors to discriminate against any person because of race, color, national origin, sex, creed, or handicap in public services and employment opportunities.

APPENDIX NO. 2

DISADVANTAGED BUSINESS ENTERPRISES - REQUIRED STATEMENTS

Policy. It is the policy of the Department of Transportation that disadvantaged business enterprises as defined in 49 CFR Part 26 shall have the maximum opportunity to participate in the performance of contracts financed in whole or in part with federal funds under this Agreement. Consequently, the DBE requirements of 49 CFR Part 26 apply to this Agreement.

DBE Obligation. The City and its contractors agree to ensure that disadvantaged business enterprises as defined in 49 CFR Part 26 have the maximum opportunity to participate in the performance of contracts financed in whole or in part with federal funds provided under this agreement. In this regard, all recipients or contractors shall take all necessary and reasonable steps in accordance with 49 CFR Part 26 to ensure that disadvantaged business enterprises have the maximum opportunity to compete for and perform contracts. The City and its contractors shall not discriminate on the basis of race, color, sex, creed or national origin in the award and performance of DOT-assisted contracts.

49 CFR 26.5 defines a DOT-assisted contract as “any contract between a recipient and a contractor (at any tier) funded in whole or in part with DOT financial assistance, including letters of credit or loan guarantees.” “Contractor” means one who participates through a contract or subcontract (at any tier) in a DOT-assisted highway, transit, or airport program.