



## Denver Zoning Code Text Amendment Modernizing Parking Requirements

LUTI COMMITTEE REVIEW DRAFT – 5/13/2025

The Modernizing Parking Requirements project proposes to remove minimum vehicle parking requirements for all land uses in the city. This draft of the proposed text amendment includes all impacted pages of the Denver Zoning Code, a bridge amendment to Former Chapter 59 in Denver Revised Municipal Code (D.R.M.C.) Section 59-2(c), and D.R.M.C. Chapter 27.

This proposed text amendment would also:

- Reorganize Division 10.4 Parking and Loading
- Remove vehicle parking exceptions, which include exemptions, alternative ratios, reductions & shared parking standards;
- Simplify the existing “Use and Minimum Parking Tables” into simplified Use Tables;
- Consolidate existing bicycle parking requirements into one article of the code; and
- Maintain existing maximum parking requirements for surface parking near transit and parking in some downtown zone districts.

More information and a background and peer cities report are available on the [project webpage](#).

### Markup Document Conventions

- Text in red underline is proposed new language.
- Text in ~~red strikethrough~~ is proposed deleted language.
- Text in blue is existing language moved to another location.
- Text in ~~blue strikethrough~~ is existing language deleted from its original location.
- Only pages with changes relevant to this text amendment are included in the review file (with the exception of a few pages inserted for context). You may wish to look at other sections for additional context.
- While efforts are made to ensure document quality, cross-referenced section numbers, figure numbers, page numbers, and amendment numbers may appear incorrect since both new and old text appears in a draft. These will be corrected in the final, “clean” version of the text amendment that is filed for adoption by City Council.

### How to submit comments

Please send comments or questions to the project team via [this form](#).

Community Planning and Development  
201 W. Colfax Ave., Dept. 205 | Denver, CO 80202  
[www.denvergov.org/cpd](http://www.denvergov.org/cpd)  
p. (720) 865-2700

CONNECT WITH US | [311](#) | [DENVERGOV.ORG](http://DENVERGOV.ORG) | [DENVER 8 TV](#)

## DIVISION 2.3 CODE ORGANIZATION

### SECTION 2.3.1 ARTICLES 3 THROUGH 7: NEIGHBORHOOD CONTEXTS

The Code is organized such that each Neighborhood Context is a separate Article. The purpose is to provide, to the extent possible, all regulations applicable to that Neighborhood Context in one location of the Code. Each Neighborhood Context Article has the same Division headings to ensure consistency when referencing regulations between Articles. Each of the Division headings are described below.

#### 2.3.1.1 Neighborhood Context Description

Each Article provides a description of the Neighborhood Context. The description is organized to describe general character; street, block and access patterns; building placement and location; building height; and mobility. The description provides the basis for the context and form based regulations.

#### 2.3.1.2 Districts

- A. This Division establishes the menu of zone districts for the Neighborhood Context. There is a list of intent statements for each zone district in the Context.
- B. Zone District Naming Convention: The zone districts for the Suburban, Urban Edge, Urban, General Urban and Urban Center Neighborhood Contexts follow a consistent naming convention, as follows:

FIRST LETTER	SECOND LETTERS	THIRD LETTER OR THIRD NUMBER	OCCASIONAL LAST NUMBER OR LETTER	EXAMPLES
<b>Neighborhood Context</b>	<b>Dominant Building Form and Character</b>	<b>Minimum Zone Lot Size in square feet or Maximum Building Height in stories</b>	<b>Special Purpose</b>	
S = Suburban E = Urban Edge U = Urban G = General Urban C = Urban Center	SU = Single Unit TU = Two Unit  RH = Row House MU = Multi Unit RO = Residential Office RX = Residential Mixed Use CC = Commercial Corridor MX = Mixed Use MS = Main Street	<u>Minimum Zone Lot Sizes</u> A = 3,000 B = 4,500 C = 5,500 D = 6,000 E = 7,000 F = 8,500 G = 9,000 H = 10,000 I = 12,000  <u>Heights*</u> 2 = 2 stories 2.5 = 2.5 stories 3 = 3 stories 5 = 5 stories 8 = 8 stories 12 = 12 stories 16 = 16 stories 20 = 20 stories  * Maximum Building Height may be increased as provided in this Code.	When there is a number or letter at the end of the zone district name, that is an indicator of special regulations. Refer to the zone district regulations for more detail. Typically:  2 = Duplexes and tandem houses allowed on certain corners  x = Special provisions tailored to that zone district  A = Special provisions, especially design standards or allowed building forms, tailored to that zone district	U-SU-A: Urban Neighborhood Context, allows single units and accessory dwelling units with a minimum zone lot size of 3,000 sf  G-MU-3: General Urban Neighborhood, allows up to multiple family uses with a maximum height of 3 stories  C-MX-5: Urban Center Neighborhood, allows commercial and residential uses with a maximum height of 5 stories.

#### 2.3.1.3 Design Standards

The Design Standards Division establishes the intent of all applicable design standards, allowed building forms by zone district, building form standards and any exceptions or alternatives. A summary table provides an overview for easy reference. Each building form has a set of illustrations and a table of standards to ensure clarity in interpretation.

#### **2.3.1.4 Uses and Required Minimum Parking**

The Uses ~~Division and Parking~~ provides a listing of all allowed uses by zone district. With each use category, the ~~vehicle and bike parking requirements~~ zoning procedure and references to applicable use limitations are listed.

### **SECTION 2.3.2 ARTICLE 8: DOWNTOWN NEIGHBORHOOD CONTEXT**

The Downtown Neighborhood Context is organized differently than Articles 3 through 7 due to the unique nature of the downtown zone districts. This Article contains all the zone districts within the city's downtown area and applicable regulations. The Downtown Neighborhood Context has a different zone district naming convention. The first letter is "D" to denote the Downtown Neighborhood Context. The second letters are abbreviations for the specific neighborhood within Downtown. For example: D-AS is Downtown Arapahoe Square. After providing the zoning regulations for each downtown zone district, there are Sections on design standards and ~~the uses, and minimum parking requirements:~~

### **SECTION 2.3.3 ARTICLE 9: SPECIAL CONTEXTS AND DISTRICTS**

Article 9 contains regulations for Special Contexts and Districts. Special Contexts and Districts are those that need to be treated differently due to specialized uses, forms, regulations and/or procedures. Special Contexts and Districts have a different zone district naming convention described within each Division. The first letters indicate the type of context or district with subsequent lettering or numbering when there is variation.

- 2.3.3.1 Industrial Context (I-MX, -A, -B): The Industrial Context establishes zone districts that allow varying intensities and types of industrial forms and uses.
- 2.3.3.2 Campus Context (CMP-H, -H2, -EI, -EI2, -ENT, -NWC, -NWC-C, -NWC-G, -NWC-F, -NWC-R): The Campus Context establishes zone districts for larger scale sites offering healthcare, education/institution, entertainment, and the National Western Center.
- 2.3.3.3 Open Space Context (OS-A, -B, -C): The Open Space Context establishes zone districts for various types of park, recreational and open space land.
- 2.3.3.4 Overlay Districts (CO, UO, DO, AIO): Overlay Districts are zone districts that apply in addition to the base zone district. There are Conservation Overlay Districts, Use Overlay Districts, Design Overlay Districts, and the Airport Influence Overlay District.
- 2.3.3.5 Denver International Airport District: This district applies to the Denver International Airport.
- 2.3.3.6 O-1 Zone District: O-1 is a zone district that applies to various recreation, institutional, and utilities.
- 2.3.3.7 Manufactured Home Community Zone District (MHC): This zone district provides form and use standards for existing Manufactured Home Communities.
- 2.3.3.8 Planned Unit Development District: The Planned Unit Development District is a unique zone district that provides form, use, parking and other standards tailored to a particular site.
- 2.3.3.9 Master Planned Context: The Master Planned Context is intended for larger scale sites that will develop over a long period of time and in multiple phases. Within the Master Planned Context there is a menu of residential and mixed use zone district.

### **SECTION 2.3.4 ARTICLES 10 THROUGH 13: GENERAL STANDARDS AND PROCEDURES**

Articles 10 through 13 contain regulations that apply throughout the city and are not unique to a Neighborhood Context or Special Context. They are organized together so that common regulations are found in the same place such as use limitations, procedures, definitions and rules of measurement.

## DIVISION 2.4 USING THE CODE

### SECTION 2.4.1 STEP BY STEP USE OF THE CODE

#### 2.4.1.1 Determine the Zone District:

Obtain a property's zoning from the Denver County assessor's records, from the Official Map or by consulting the city's website: [www.denvergov.org](http://www.denvergov.org). Take note of any Overlay Districts that apply. Also take note of zoning for adjacent properties, and specifically whether or not the subject property is in, or adjacent to, a Protected Zone District, as defined in Division 13.3, Definitions of Words, Terms & Phrases.

#### 2.4.1.2 Find the Neighborhood Context Article:

Zone districts are organized by Neighborhood Context in the Code. The first letter of the zone district indicates the applicable Neighborhood Context. Go to the applicable Article of the Code (Article 3 through Article 9) for the relevant zoning regulations. For example, if the property is zoned U-SU-A, the first "U" in the zone district name indicates the context – in this case, the "U"rban Neighborhood Context, refer to Article 5, Urban Neighborhood Context.

#### 2.4.1.3 Understand the Neighborhood Context:

Gain further understanding of the neighborhood context by reviewing the Neighborhood Context Description, which is the first Division in each Neighborhood Context Article. For example, read Division 5.1, Neighborhood Context Description, for a description of the Urban Neighborhood Context.

#### 2.4.1.4 Review the Applicable Zone Districts:

To understand which zone districts apply in the Neighborhood Context, read Districts, which is the second Division in all Neighborhood Context Articles. Review the intent statement for your zone district to understand its general purpose and how it relates to other zone districts in that context. For example, read Division 5.2, Districts (U-SU-, U-TU-, U-RH-, U-MX-, U-RX-, U-MS-), for a zone district listing and intent statements for the Urban Neighborhood Context. Refer to Division 9.4, Overlay Zone Districts for information on relevant overlay zone districts.

#### 2.4.1.5 Choose a Building Form:

The zone district allow a variety of building forms appropriate for the context. Review Design Standards, the third Division in all Neighborhood Context Articles, for a listing of allowed primary and accessory building forms by zone district. Next, find the building form you want to construct or alter, and use the associated graphic and table to determine allowed building setbacks, height and other regulations. Primary Building Forms are listed separately from Detached Accessory Building Form standards. One building form and the associated standards must be selected. For example, read Section 5.3.3, Building Form Standards for Primary Structures, in Division 5.3, Design Standards. A table at the beginning of this Section summarizes which building forms are appropriate in each Urban Neighborhood Context zone district. Assume, for example, you want to build an Urban House in the U-SU-A zone district. Read Section 5.3.3.A, District Specific Standards, for the applicable standards for the Urban House form in the Urban Neighborhood Context. Review the graphic and read the table to find standards for this building form applicable to the U-SU-A zone district. Read Section 5.3.5 through 5.3.8 to find additional design standards and to understand permitted exceptions and alternatives to meeting the building form standards. If a term is not clear, refer to Article 13, Rules of Measurement & Definitions.

#### 2.4.1.6 Identify Allowable Uses **and Required Parking:**

The last Division of each Neighborhood Context Article states the allowed land uses **and required vehicle and bicycle parking** in each zone district. To find what uses are allowed in a particular zone district, consult the Uses Table at the end of the Article. Allowed primary, accessory, and temporary uses **and the relevant vehicle and bike parking requirements** are listed in the first column of the Use Table and zone districts are listed across the remaining table columns. Table cell

entries for each use indicates whether the use is allowed in the zone district or allowed subject to specific limitations, and/or subject to a specific review. If the use is not allowed it will be indicated as Not Permitted (NP). The last column of the Use Table references the user to all applicable use limitations. Some use limitations are contained within the Article and some, that apply to several zone districts, are found in Article 11, Use Limitations and Definitions. In some cases, use limitations reference their applicability to Residential Zone Districts or Mixed Use Commercial Zone Districts. Refer to Article 13, Rules of Measurement & Definitions for a listing of which zone districts are categorized as such. Unless otherwise specified, any use can occupy any building form provided they are allowed in the zone district. If you need a use summary, use definitions, or use limitations refer to Article 11, Use Limitations and Definitions.

#### **2.4.1.7 Review the General Design Standards:**

Review Article 10, General Design Standards which includes standards that are generally applicable to all new development, regardless of neighborhood context. Standards address vehicle and bicycle parking, loading, multi-structure developments, landscaping, outdoor lighting, outdoor storage and display, signs, and general performance standards. ~~For example, Division 10.4, Parking and Loading provides exceptions and reductions that may be available.~~ In some cases, design standards reference their applicability to Residential Zone Districts or Mixed Use Commercial Zone Districts. Refer to Article 13, Rules of Measurement & Definitions for a listing of which zone districts are categorized as such.

#### **2.4.1.8 Understand Zoning Procedures and Enforcement:**

Review Article 12, Zoning Procedures and Enforcement to gain an understanding of all zoning procedures applicable to new development. The Article first identifies all the review and decision-making bodies and their respective roles under this Code, then describes steps common to most or all zoning procedures (e.g., public notice requirements), and then describes the steps required for each type of zoning procedure (e.g., zoning permit review, special exception review, rezonings, and variances). A summary of review and decision making authority and type of public notice required for each procedure is provided in Section 12.3.4, Public Notice Requirements. Article 12, Zoning Procedures and Enforcement also contains the rules for nonconforming and compliant uses, structures, and lots. Finally, Article 12, Zoning Procedures and Enforcement contains general enforcement provisions, including what constitutes a violation of the Code and the associated penalties.

## SECTION 3.3.3 BUILDING FORM STANDARDS FOR PRIMARY STRUCTURES

### 3.3.3.1 Applicability

All development, except detached accessory structures, in all the Suburban Neighborhood Context zone districts.

### 3.3.3.2 District Specific Standards Summary

The table below states the building forms allowed in each zone district. The table also summarizes the maximum number of structures allowed per Zone Lot, which is stated in more detail in Section 1.2.3.5, Number of Uses and Structures Allowed per Zone Lot.

See also Division 1.4, Building Form Standards - General Provisions, for additional standards related to initial assignment of building form standards to new and existing structures and for rules governing combining or changing building forms. Building Connectors between two detached structures shall follow the standards provided in Section 1.4.5, Applicable Building Form Standards for Detached Structures with Building Connector.

Suburban (S-) Neighborhood Context Zone Districts		Building Forms											
		Suburban House	Urban House	Duplex	Tandem House	Row House	Garden Court	Town House	Apartment	Drive Thru Services	Drive Thru Restaurants	General	Shopfront
<b>Max Number of Primary Structures per Zone Lot</b>		1*		1*	2	No Maximum							
<b>RESIDENTIAL ZONE DISTRICTS</b>													
Single Unit (SU)	S-SU-A, -D, -F, -Fx, -I, -Ix,	■			●								
	S-SU-FA	■			■								
Row House (RH)	S-RH-2.5	■		■		■							
Multi Unit (MU)	S-MU-3, -5, 8, 12, 20	■		■		■			■				
<b>MIXED USE COMMERCIAL ZONE DISTRICTS</b>													
Commercial Corridor (CC)	S-CC-3, -3x, -5, -5x								□	□	■		
Mixed Use (MX)	S-MX-2x										■	■	
	S-MX-2, -3, -5, -8, -12								□	□	■	■	
	S-MX-2A, -3A, -5A, -8A, -12A										■	■	
Main Street (MS)	S-MS-3, -5								□	□		■	

■ = Allowed □ = Allowed subject to geographic limitations

● = Tandem House building form allowed subject to exception stated in Section 1.2.3.5.B, Allowed Increases on Zone Lot with Certain Existing Accessory Structures in SU- and TU Zone Districts

\*No Maximum # of primary structures per zone lot in the S-RH and S-MU Zone Districts.

### 3.3.3.3 District Specific Standards

#### A. Suburban House

Not to Scale. Illustrative Only.

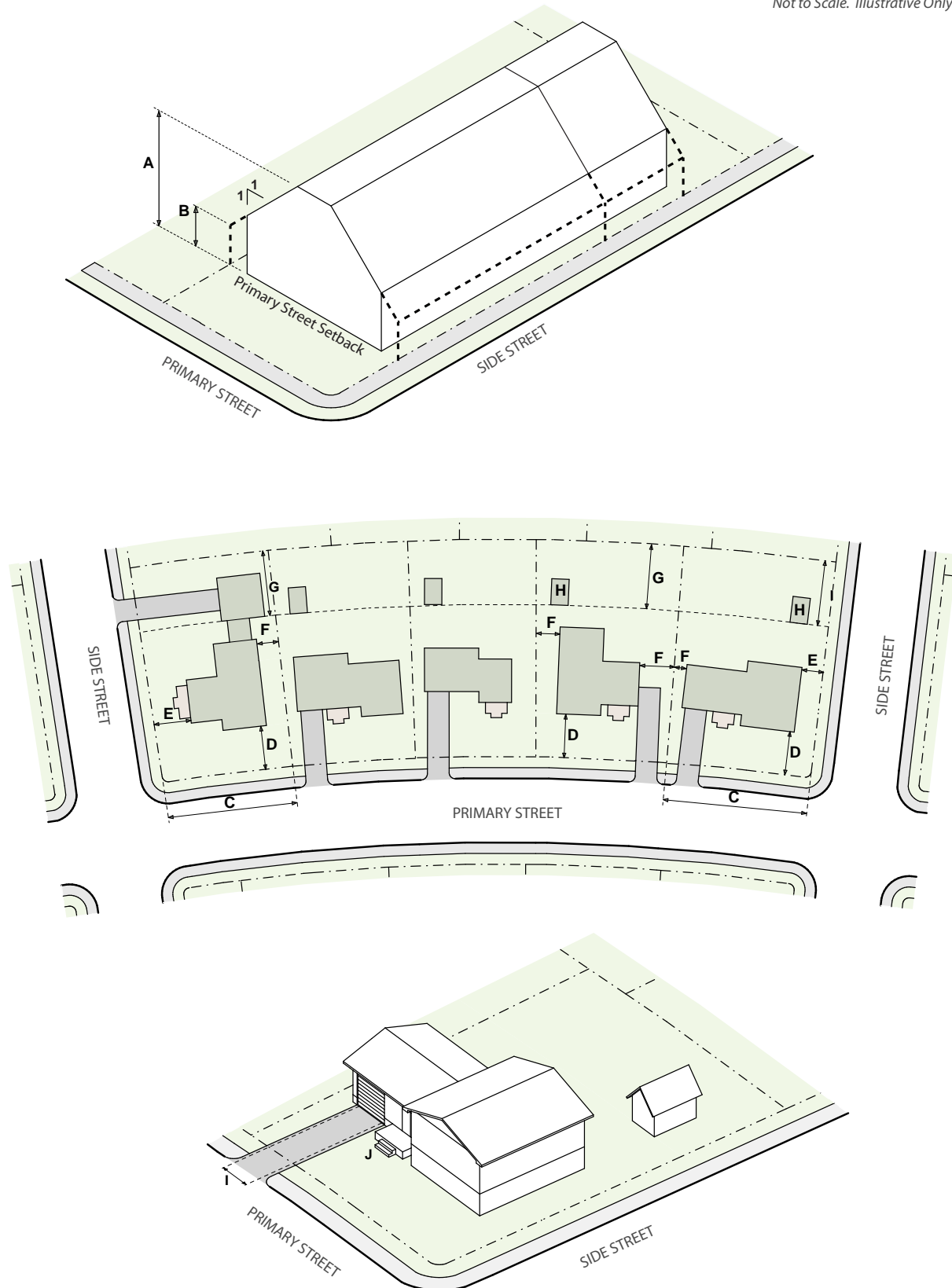

# SUBURBAN HOUSE

		S-SU-F					
		S-SU-A	S-SU-D	S-SU-Fx	S-SU-I	All S-RH	All S-MU
<b>HEIGHT</b>							
A	Stories, front 65% / rear 35% of zone lot depth (max)	2.5/2.5	2.5/2.5	2.5/2.5	3/3	2.5/2.5	3/3
A	Feet, front 65% / rear 35% of zone lot depth (max)	30'/30'	30'/30'	30'/30'	30'/30'	30'/30'	32'/32'
	Feet, 100% of zone lot depth, permitted height increase (max)	1' for every 5' increase in Zone Lot width over 50' up to a maximum height of 35'					
B	Bulk Plane Vertical Height at Side Interior and Side Street Zone Lot Line in front 65% / rear 35% of zone lot depth	10'/10'	10'/10'	10'/10'	10'/10'	10'/10'	na
	Bulk Plane Slope from Side Interior and Side Street Zone Lot Line	45°	45°	45°	45°	45°	na
		S-SU-F					
		S-SU-A	S-SU-D	S-SU-Fx	S-SU-I	All S-RH	All S-MU
<b>SITING</b>							
<b>ZONE LOT</b>							
	Zone Lot Area (min)	3,000 sf	6,000 sf	8,500 sf	12,000 sf	6,000 sf	6,000 sf
C	Zone Lot Width (min)	25'	50'	62.5'	62.5'	50'	50'
		All S-SU, RH, MU					
		25' or Less	Greater than 25' and less than 62'	62' or Greater			
D	Primary Street (min)	15'	For -MU Districts: Calculated per Sec. 13.1.5.9 or 20'; whichever is less For all other Districts: Calculated per Sec. 13.1.5.9				
E	Side Street (min)	3'	5'	5'			
F	Side Interior (min)	3'	5'	7.5'			
G	Rear, where Alley (public or private) abuts a Rear Zone Lot Line (min)	12'	12'	12'			
G	Rear, where Alley (public or private) does not abut a Rear Zone Lot Line (min)	20'	20'	20'			
	Building Coverage per Zone Lot, including all accessory structures (max)	50%	50%	50%			
<b>PARKING BY ZONE LOT WIDTH</b>							
	Parking and Drive Lot Coverage in Primary Street Setback (max)	Maximum 16 feet wide measured parallel to the Primary Street zone lot line for any length, or 33% of the zone lot area within the Primary Street setback, whichever is greater					
	Vehicle Access	From Alley; or Street access allowed when no Alley present (See Sec. 3.3.7.5)					
H	<b>DETACHED ACCESSORY STRUCTURES</b>	See Sec. 3.3.4					
		S-SU-F					
		S-SU-A	S-SU-D	S-SU-Fx	S-SU-I	All S-RH	All S-MU
<b>DESIGN ELEMENTS</b>							
<b>BUILDING CONFIGURATION</b>							
	Rooftop or Second Story Decks	See Section 3.3.5.2					
	Attached Garage Allowed	(1) Shall not be located closer to the minimum Primary Street Zone Lot Line than the Primary Street-facing Façade(s) comprising at least 65% of the total width of the primary structure enclosing the Primary Use. (2) May follow the General Detached Structure Building Form for Side Street, Side Interior and Rear setbacks provided no permitted height increase has been applied to the Attached Garage.					
I	Primary Street-Facing Attached Garage Door Width in front 50% of zone lot depth (max)	35% of the entire width of the Primary Street-facing Façade of the primary structure or 16' feet, whichever is greater					
	Upper Story Stepback, for any portion of building with Low-Slope Roof, above 25': Primary Street (min)	10'	10'	10'	na	10'	na
<b>STREET LEVEL ACTIVATION</b>							
J	Pedestrian Access, Primary Street	Entry Feature					
<b>USES</b>		All S-SU, RH, MU					
		Primary Uses shall be limited to Single Unit Dwelling and permitted Congregate Living, Residential Care and Nonresidential uses. See Division 3.4, Uses <b>and Required Minimum Parking</b> .					

See Sections 3.3.5 - 3.3.7 for Supplemental Design Standards, Design Standard Alternatives and Design Standard Exceptions



## DUPLEX

<b>HEIGHT</b>		S-RH-2.5	S-MU-3, -5, -8, -12, -20
A	Stories, front 65% / Rear 35% of zone lot depth (max)	2.5/2.5	3/3
A	Feet, front 65% / rear 35% of zone lot depth (max)	30'/30'	32'/32'
	Feet, permitted height increase	1' for every 5' increase in Zone Lot width over 50' up to a maximum height of 35'	
B	Bulk Plane Vertical Height at Side Interior and Side Street Zone Lot Line in front 65% / rear 35% of zone lot depth	10'/10'	na
	Bulk Plane Slope from Side Interior and Side Street Zone Lot Line	45°	na
<b>SITING</b>		S-RH-2.5	S-MU-3, -5, -8, -12, -20
<b>ZONE LOT</b>			
	Zone Lot Area (min)	4,500 sf	4,500 sf
C	Zone Lot Width (min)	37.5'	37.5'
<b>SETBACKS AND BUILDING COVERAGE BY ZONE LOT WIDTH</b>		All S-RH and S-MU Districts	
		61' or Less	Greater than 61'
		For -MU Districts: Calculated per Sec. 13.1.5.9 or 20', whichever is less	
		For all other Districts: Calculated per Sec. 13.1.5.9	
D	Primary Street (min)		
E	Side Street (min)	5'	5'
F	Side Interior (min)	5'	5'
G	Rear, where Alley (public or private) abuts a Rear Zone Lot Line (min)	12'	12'
G	Rear, where Alley (public or private) does not abut a Rear Zone Lot Line (min)	20'	20'
	Building Coverage per Zone Lot, including all accessory structures (max)	50%	50%
<b>PARKING BY ZONE LOT WIDTH</b>			
	Parking and Drive Lot Coverage in Primary Street Setback (max %)	50%	50%
	Vehicle Access	From Alley; or Street access allowed when no Alley present (See Sec 3.3.7.5)	
H	<b>DETACHED ACCESSORY STRUCTURES</b>	See Sec. 3.3.4	
<b>DESIGN ELEMENTS</b>		S-RH-2.5	S-MU-3, -5, -8, -12, -20
<b>BUILDING CONFIGURATION</b>			
	Rooftop or Second Story Decks	See Section 3.3.5.2	
	Attached Garage Allowed	(1) Shall not be located closer to the minimum Primary Street Zone Lot Line than the Primary Street-facing Façade(s) comprising at least 65% of the total width of the primary structure enclosing the Primary Use. (2) May follow the General Detached Structure Building Form for Side Street, Side Interior and Rear setbacks provided no permitted height increase has been applied to the Attached Garage.	
I	Primary Street-Facing Attached Garage Door Width in front 50% of zone lot depth (max)	35% of the entire width of the Primary Street-facing Façade of the primary structure or 16', whichever is greater	
	Upper Story Stepback, for any portion of building with Low-Slope Roof, above 25': Primary Street (min)	10'	na
<b>STREET LEVEL ACTIVATION</b>			
J	Pedestrian Access, Primary Street	Entry Feature	
<b>USES</b>		All S-RH and S-MU Districts	
		Primary Uses shall be limited to Two Unit Dwelling and permitted Congregate Living, Residential Care and Nonresidential uses. See Division 3.4, Uses, <del>and Required</del> <b>Minimum Parking</b>	

See Sections 3.3.5 - 3.3.7 for Supplemental Design Standards, Design Standard Alternatives and Design Standard Exceptions

## TANDEM HOUSE

<b>HEIGHT</b>		S-SU-FA
A	Stories (max)	2.5
A	Feet (max)	30'
	Feet, permitted height increase	1' for every 5' increase in Zone Lot width over 50' up to a maximum height of 35'
B	Bulk Plane Vertical Height at Side Interior and Side Street Zone Lot Line	10'
	Bulk Plane Slope from Side Interior/Side Street Zone Lot Line	45°
<b>SITING</b>		S-SU-FA
<b>ZONE LOT</b>		
	Zone Lot Area (min)	12,000 sf
C	Zone Lot Width (min)	62.5'
	Zone Lot Depth (min)	150'
	Number of Primary Structures per Zone Lot (max)	2
<b>SETBACKS AND BUILDING COVERAGE</b>		
D	Primary Street (min)	Calculated per Sec. 13.1.5.9
E	Side Street (min)	10'
F	Side Interior, for Primary Structure #1 (min one side/min combined)	5'/15'
G	Side Interior, for Primary Structure #2 (min one side/min combined)	5'/15'
H	Rear, for Primary Structure #1, as a % of zone lot depth (min)	50%
I	Rear, for Primary Structure #2 (min)	5'
	Building Coverage per Zone Lot, including all accessory structures (max)	50%
<b>BUILDING SEPARATION</b>		
J	Horizontal distance between closest above-grade portions of each Primary Structure (min)	6'
<b>PARKING BY ZONE LOT WIDTH</b>		
	Parking and Drive Lot Coverage in Primary Street Setback (max %)	50%
	Vehicle Access	From Alley; or Street access allowed when no Alley present (See Sec. 3.3.7.5)
<b>DETACHED ACCESSORY STRUCTURES</b>		See Sec. 3.3.4
<b>DESIGN ELEMENTS</b>		S-SU-FA
<b>BUILDING CONFIGURATION</b>		
	Rooftop or Second Story Decks	See Section 3.3.5.2
	Attached Garage Allowed	(1) Shall not be located closer to the minimum Primary Street Zone Lot Line than the Primary Street-facing Façade(s) comprising at least 65% of the total width of the primary structure enclosing the Primary Use. (2) May follow the General Detached Structure Building Form for Side Street, Side Interior and Rear setbacks provided no permitted height increase has been applied to the Attached Garage.
	Primary Street-Facing Attached Garage Door Width in front 50% of zone lot depth (max)	35% of the entire width of the Primary Street-facing Façade of the primary structure or 16', whichever is greater
	Upper Story Stepback, for any portion of building with Low-Slope Roof, above 25': Primary Street (min), for Structure #1 and for Structure #2 in front 50% of zone lot depth	10'
<b>STREET LEVEL ACTIVATION</b>		
K	Pedestrian Access, Primary Street	Primary Structure #1: Entry Feature Primary Structure #2: No Requirement
<b>USES</b>		S-SU-FA
		Primary Uses shall be limited to Single Unit Dwelling per primary structure. See Division 3.4, Uses, <u>and Required Minimum Parking</u>

See Sections 3.3.5 - 3.3.7 for Supplemental Design Standards, Design Standard Alternatives, and Design Standard Exceptions.

## ROW HOUSE

<b>HEIGHT</b>		S-RH-2.5	S-MU-3	S-MU- 5, 8, 12, 20
A	Stories (max)	2.5	3	5
A	Feet (max)	35'	35'	65'
B	Side Wall Height (max)	25'	na	na
<b>SITING</b>		S-RH-2.5	S-MU-3	S-MU- 5, 8, 12, 20
<b>ZONE LOT</b>				
	Zone Lot Area (min)	6,000 sf	6,000 sf	6,000 sf
C	Zone Lot Width (min)	50'	50'	50'
	Dwelling Units per Primary Residential Structure (max)	10	na	na
<b>REQUIRED BUILD-TO</b>				
D	Primary Street (min % within min/max)	na	50% 0'/80'	50% 0'/80'
<b>SETBACKS</b>				
E	Primary Street (min)	Calculated per Sec. 13.1.5.9	10'	10'
F	Side Street (min)	5'	5'	5'
G	Side Interior (min)	5'	5'	5'
H	Side Interior, adjacent to Protected District (min)	na	10'	10'
	Rear, where an Alley (public or private) abuts a Rear Zone Lot Line (min)	12'	10'	10'
	Rear, where an Alley (public or private) does not abut a Rear Zone Lot Line (min)	20'	20'	20'
	Rear, adjacent to Protected District (min)	na	na	na
<b>PARKING</b>				
	Vehicle Access	From Alley; or Street access allowed when no Alley present		
<b>DESIGN ELEMENTS</b>		S-RH-2.5	S-MU-3	S-MU- 5, 8, 12, 20
<b>BUILDING CONFIGURATION</b>				
I	Dwelling Units Oriented to the Street	All Dwelling Units shall be Oriented to the Street		
	Dwelling Unit Configuration	Structure shall only contain Side-by-Side-Dwelling Units		
J	Primary Street-Facing Attached Garage Door Width (max per unit)	10'	10'	10'
K	Upper Story Stepback, for any portion of building with Low-Slope Roof, above 25': Primary Street, Side Street and Side Interior (min)	10'	na	na
	Upper Story Setback above 40', Side Interior	na	na	15'
	Upper Story Setback above 51', Side Interior	na	na	15'
L	Upper Story Setback above 27', adjacent to Protected District: Side Interior	na	25'	25'
	Upper Story Setback above 27', adjacent to Protected District: Rear, alley/Rear, no alley and Side Interior (min)	na	na	20'/25'
	Upper Story Setback above 40', adjacent to Protected District: Rear, alley/Rear, no alley (min)	na	na	30'/40'
	Upper Story Setback above 51', adjacent to Protected District: Side Interior (min)	na	na	40'
	Rooftop or Second Story Decks	See Section 3.3.5.2		
<b>STREET LEVEL ACTIVATION</b>				
M	Transparency, Primary Street (min)	30%	30%	30%
	Transparency, Side Street (min)	25%	25%	25%
N	Pedestrian Access	Each unit shall have a street-facing Entrance		
<b>USES</b>				
All S-RH and S-MU Districts				
Primary Uses shall be limited to Multi-Unit Dwelling uses. See Division 3.4, Uses, and Required Minimum Parking				

See Sections 3.3.5 - 3.3.7 for Supplemental Design Standards, Design Standard Alternatives, and Design Standard Exceptions.

## APARTMENT

<b>HEIGHT</b>		S-MU-3	S-MU-5	S-MU-8	S-MU-12	S-MU-20
A	Stories (max)	3	5	8	12	20
A	Feet (max)	40'	65'	100'	140'	230'
	Stories/Feet, with incentives (max)	4/50'	7/90'	12/140'	16/185'	30/340'
	Feet, within 175' of Protected District (max)	na	75'	75'	75'	75'
		See Section 10.12.1, Height Incentives				
<b>SITING</b>		S-MU-3	S-MU-5	S-MU-8	S-MU-12	S-MU-20
<b>ZONE LOT</b>						
	Zone Lot Area (min)	6,000 sf	6,000 sf	6,000 sf	6,000 sf	6,000 sf
	Zone Lot Width (min)	50'	50'	50'	50'	50'
<b>REQUIRED BUILD-TO</b>						
B	Primary Street (min % within min/max)	50% 0'/80'	50% 0'/80'	50% 0'/80'	50% 0'/80'	50% 0'/80'
<b>SETBACKS</b>						
C	Primary Street (min)	10'	10'	10'	10'	10'
D	Side Street (min)	5'	5'	5'	5'	5'
E	Side Interior (min)	7.5'	7.5'	7.5'	7.5'	7.5'
	Side Interior adjacent to Protected District (min)	10'	10'	10'	10'	10'
F	Rear, where Alley (public or private) abuts a Rear Zone Lot Line (min)	10'	10'	10'	10'	10'
F	Rear, where Alley (public or private) does not abut a Rear Zone Lot Line (min)	20'	20'	20'	20'	20'
	Building Coverage per Zone Lot, including all accessory structures (max)	na	na	na	70%	70%
<b>PARKING</b>						
	Surface Parking between building and Primary Street/Side Street	Allowed/Allowed				
	Vehicle Access, 3 or more Side-by-Side Dwelling Units in One Structure	From Alley; or Street access allowed when no Alley present, according to Section 3.3.7.5				
	Vehicle Access, all other permitted uses	Access determined at Site Development Plan Review				
<b>DESIGN ELEMENTS</b>		S-MU-3	S-MU-5	S-MU-8	S-MU-12	S-MU-20
<b>BUILDING CONFIGURATION</b>						
	Primary Street-Facing Attached Garage Door Width (max per structure)	20'	20'	20'	20'	20'
H	Upper Story Setback Above 40', Side Interior	na	15'	na	na	na
	Upper Story Setback Above 51', Side Interior	na	na	15'	15'	15'
I	Upper Story Setback Above 75', Rear, alley/Rear, no alley and Side Interior	na	na	20'/30'	20'/30'	20'/30'
J	Upper Story Setback above 27', adjacent to Protected District: Side Interior (min)	25'	25'	25'	25'	25'
K	Upper Story Setback Above 40', adjacent to Protected District: Rear, alley/no alley	na	30'/40'	30'/40'	30'/40'	30'/40'
	Upper Story Setback above 51', adjacent to Protected District: Side Interior (min)	na	40'	40'	40'	40'
<b>STREET LEVEL ACTIVATION</b>						
L	Transparency, Primary Street (min)	30%	30%	30%	30%	30%
M	Transparency, Side Street (min)	25%	25%	25%	25%	25%
N	Pedestrian Access, Primary Street	Pedestrian Connection				
<b>USES</b>		All S-MU				
		Primary Uses shall be limited to Multi Unit Dwelling and permitted Congregate Living, Residential Care, and Nonresidential uses.				
		See Division 3.4, Uses, <del>and Required Minimum Parking</del>				

See Sections 3.3.5 - 3.3.7 for Supplemental Design Standards, Design Standard Alternatives and Design Standard Exceptions

## DRIVE THRU SERVICES

<b>APPLICABILITY</b>		All S-CC, S-MX, and S-MS			
Form is not permitted on Zone Lots within 1/4 mile of the outer boundary of a Rail Transit Station Platform					
<b>HEIGHT</b>		S-MX-2	S-CC-3, -3x, -5, -5x S-MX-3, -5, -8, -12 S-MS-3, -5		
Stories (max)		2	3		
Feet (max)		30'	45'		
<b>SITING</b>		S-CC-3, -3x, -5, -5x	S-MS-3, -5	S-MX-2, -3, -5, -8, -12	
<b>REQUIRED BUILD-TO</b>					
Primary Street (min % within min/max)*		na	50% 0'/15'	na	
Side Street (min % within min/max)*		na	50% 0'/15'	na	
<b>SETBACKS</b>					
Primary Street (min)		0'	0'	0'	
Side Street (min)		0'	0'	0'	
Side Interior (min)		0'	0'	0'	
A Side Interior, adjacent to Protected District (min)		10'	10'	10'	
Rear (min)		0'	0'	0'	
Rear, adjacent to Protected District, where an Alley (public or private) does not abut a Rear Zone Lot Line (min)		10'	10'	10'	
<b>PARKING</b>					
B Surface Parking between building and Primary Street/Side Street		Allowed/Allowed	Not Allowed/Allowed	Allowed/Allowed	
<b>DESIGN ELEMENTS</b>		S-CC-3, -3x, -5, -5x	S-MS-3, -5	S-MX-2, -3, -5, -8, -12	
<b>BUILDING CONFIGURATION</b>					
C *Canopy		na	Building shall be used to meet a portion of the Primary and Side Street Build-To. Canopy may be used to meet a portion of the Primary and Side Street Build-To.	na	
D Screening Required		See Article 10	Garden Wall required within 0'/15' for 100% of the zone lot's Primary and Side Street frontages, excluding access points and portions of building within 0'/15'; according to Section 10.5.4.4, Perimeter Surface Parking Lot Landscaping Standards		
Upper Story Setback Above 27', adjacent to Protected District: Rear, alley/ Rear, no alley and Side Interior (min)		15'/25'	15'/25'	15'/25' S-MX-2: na	
<b>STREET LEVEL ACTIVATION</b>					
E Transparency, Primary Street (min)		40%*	60%	40%*	
F Transparency, Side Street (min)		25%*	25%	25%*	
G Pedestrian Access, Primary Street		Pedestrian Connection	Entrance	Pedestrian Connection	
<b>USES</b>		All S-CC, S-MX, and S-MS			
All permitted Primary Uses shall be allowed within this building form, if the building form includes at least one of the following: (1) an Automobile Services, Light Primary Use, or (2) a Primary Use with Accessory Drive Thru Use, excluding Eating & Drinking Establishments. See Division 3.4, Uses, <del>and Required Minimum Parking.</del>					

\*Applies only to street-facing portions of building Façade located within 80' of the Primary and/or Side Street.

## DRIVE THRU RESTAURANT

### APPLICABILITY

All S-CC, S-MX, and S-MS

Form is not permitted on Zone Lots within 1/4 mile of the outer boundary of a Rail Transit Station Platform

### HEIGHT

	S-MX-2	S-CC-3, -3x, -5, -5x S-MX-3, -5, -8, -12 S-MS-3, -5
Stories (max)	2	3
Feet (max)	30'	45'

### SITING

	S-CC-3, -3x, -5, -5x	S-MX-2, 3, -5, -8, -12	S-MS-3, -5
<b>REQUIRED BUILD-TO</b>			
Primary Street (min % within min/max)	na	50% 0'/80'	50% 0'/35'
Side Street (min % within min/max)	na	na	50% 0'/18'
<b>SETBACKS</b>			
Primary Street (min)	0'	0'	0'
Side Street (min)	0'	0'	0'
Side Interior (min)	0'	0'	0'
Side Interior, adjacent to Protected District (min)	10'	10'	10'
Rear (min)	0'	0'	0'
Rear, adjacent to Protected District, where an Alley (public or private) abuts a Rear Zone Lot Line (min)	0'	0'	0'
Rear, adjacent to Protected District, where an Alley (public or private) does not abut a Rear Zone Lot Line (min)	10'	10'	10'
<b>PARKING</b>			
Surface Parking between building and Primary Street/Side Street	Allowed/Allowed	Allowed/Allowed	Not allowed/Not Allowed
<b>A</b> Drive Thru Lane between building and Primary Street/Side Street	Allowed/Allowed	Allowed/Allowed	Allowed/Allowed
Drive Thru Lane Width (max)	na	na	12'
<b>B</b> Drive Thru Lane Screening	na	na	Garden Wall, according to Section 10.5.4.4

### DESIGN ELEMENTS

	S-CC-3, -3x, -5, -5x	S-MX-2, -3, -5, -8, -12	S-MS-3, -5
<b>BUILDING CONFIGURATION</b>			
Upper Story Setback Above 27', adjacent to Protected District: Rear, alley/ Rear, no alley and Side interior (min)	15'/25'	15'/25' S-MX-2: na	15'/25'
<b>STREET LEVEL ACTIVATION</b>			
<b>C</b> Transparency, Primary Street (min)	40%*	40%	60%
<b>D</b> Transparency, Side Street (min)	25%*	25%	25%
<b>E</b> Pedestrian Access, Primary Street	Pedestrian Connection	Pedestrian Connection	Entrance and Pedestrian Connection

### USES

All S-CC, S-MX, and S-MS

All permitted Primary Uses shall be allowed within this building form, if the building form includes a minimum of one Eating & Drinking Establishment Primary Use with Accessory Drive Thru Use. See Division 3.4, Uses, **and Required Minimum Parking:**

\*Applies only to street-facing portions of building Façade located within 80' of the Primary and/or Side Street

## GENERAL (1 OF 3)

		S-CC-3	S-CC-5
<b>HEIGHT</b>		S-CC-3x	S-CC-5x
Stories (max)		3	5
Feet (max)		45'	70'
Stories/Feet, with incentives (max)		4/55'	7/95'
Feet, within 175' of Protected District (max)		na	75'
		See Section 10.12.1, Height Incentives	
<b>SITING</b>		S-CC-3, -3x, -5, -5x	
<b>SETBACKS</b>			
Primary Street (min)		0'	
Side Street (min)		0'	
Side Interior (min)		5'	
<b>A</b> Side Interior, adjacent to Protected District (min)		10'	
Rear (min)		0'	
Rear, adjacent to Protected District, where Alley (public or private) abuts a Rear Zone Lot Line (min)		0'	
Rear, adjacent to Protected District, where Alley (public or private) does not abut a Rear Zone Lot Line (min)		10'	
<b>PARKING</b>			
<b>B</b> Surface Parking between building and Primary Street/ Side Street		Allowed/Allowed	
<b>C</b> Surface Parking Screening		See Division 10.5, Landscaping, Fences, Walls and Screening	
Vehicle Access, 3 or more side-by-side dwelling units in one structure		From Alley; or Street access allowed when no Alley present, according to Section 3.3.7.5	
Vehicle Access, all other permitted uses		Access determined at Site Development Plan Review	
		S-CC-3	S-CC-5
<b>DESIGN ELEMENTS</b>		S-CC-3x	S-CC-5x
<b>BUILDING CONFIGURATION</b>			
<b>D</b> Upper Story setback above 27'; adjacent to Protected District: Rear, alley/Rear, no alley and Side Interior (min)		15'/25'	20'/25'
<b>E</b> Upper story setback above 51'; adjacent to Protected District: Rear, alley/Rear, no alley and Side Interior (min)		na	35'/40'
<b>STREET LEVEL ACTIVATION</b>			
<b>F</b> Transparency, Primary Street (min)		40%*	
<b>G</b> Transparency, Side Street (min)		Residential Only Buildings: 30%*	
Transparency Alternatives		25%*	
<b>H</b> Pedestrian Access, Primary Street		See Section 3.3.6.3	
		Pedestrian Connection	
<b>USES</b>		All S-CC	
All permitted Primary Uses shall be allowed within this building form. See Division 3.4, Uses, <del>and Required Minimum Parking</del>			

\*Applies only to street-facing portions of building façade located within 80' of the Primary and/or Side Street  
See Sections 3.3.5 - 3.3.7 for Supplemental Design Standards, Design Standard Alternatives, and Design Standard Exceptions.

## GENERAL (2 OF 3)

HEIGHT	S-MX-2x	S-MX-2	S-MX-3	S-MX-5	S-MX-8	S-MX-12
Stories (max)	2	2	3	5	8	12
Feet (max)	30'	30'	45'	70'	110'	150'
Stories/Feet, with incentives (max)	na	na	4/55'	7/95'	12/150'	16/200'
Feet, within 175' of Protected District (max)	na	na	na	75'	75'	75'

SITING	All S-MX Option A	All S-MX Option B
RESTRICTION	na	Allowed only if Street Level GFA is equal or greater than 20,000 sf
REQUIRED BUILD-TO		
A Primary Street (min build-to % within min/max range)	50% 0'/80'	50% 0'/150'
SETBACKS		
Primary Street (min)	0'	0'
Side Street (min)	0'	0'
Side Interior (min)	0'	0'
B Side Interior, adjacent to Protected District (min)	10'	10'
Rear (min)	0'	0'
Rear, adjacent to Protected District, where Alley (public or private) abuts a Rear Zone Lot Line (min)	S-MX-2x: 12' All Other Zone Districts: 0'	S-MX-2x: 12' All Other Zone Districts: 0'
Rear, adjacent to Protected District, where Alley (public or private) does not abut a Rear Zone Lot Line (min)	S-MX-2x: 20' All Other Zone Districts: 10'	S-MX-2x: 20' All Other Zone Districts: 10'
PARKING		
C Surface Parking between building and Primary Street/Side Street	Allowed/Allowed	Allowed, limited to two double loaded aisles within the Build-To range/Allowed Garden Wall required within 0'/15' for 100% of the zone lot's Primary and Side Street frontages, excluding access points and portions of building within 0'/15', according to Section 10.5.4.4, Perimeter Surface Parking Lot Landscaping Standards
D Surface Parking Screening	See Division 10.5, Landscaping, Fences, Walls and Screening	
Vehicle Access, 3 or more side-by-side dwelling units in one structure		From Alley; or Street access allowed when no Alley present See Section 3.3.7.5
Vehicle Access, all other permitted uses		Access determined at Site Development Plan Review

DESIGN ELEMENTS	S-MX-2x	S-MX-2	S-MX-3	S-MX-5	S-MX-8	S-MX-12
BUILDING CONFIGURATION						
E Upper Story setback above 27', adjacent to Protected District: Rear, alley/Rear, no alley and Side Interior (min)	na	na	15'/25'	20'/25'	20'/25'	20'/25'
F Upper story setback above 51', adjacent to Protected District: Rear, alley/Rear, no alley and Side Interior (min)	na	na	na	35'/40'	35'/40'	35'/40'
STREET LEVEL ACTIVATION						
G Transparency, Primary Street (min)				40%*	Residential Only Buildings: 30%*	
H Transparency, Side Street (min)				25%*		
Transparency Alternatives				See Section 3.3.6.3		
I Pedestrian Access, Primary Street				Pedestrian Connection		

USES	S-MX-2x, -2, -3, -5, -8, -12
	(1) All permitted Primary Uses shall be allowed within this building form. See Division 3.4, Uses and Required Minimum Parking; and (2) 40% of the street-facing portions of building façade located within 80' of the Primary Street shall be occupied by Street Level active uses according to Section 3.3.5.3.

\*Applies only to street-facing portions of building Façade located within 80' of the Primary and/or Side Street.

See Sections 3.3.5 - 3.3.7 for Supplemental Design Standards, Design Standard Alternatives, and Design Standard Exceptions.



## SHOPFRONT

	S-MX-2	S-MS-3	S-MS-5		
	S-MX-2x	S-MX-3	S-MX-5	S-MX-8	S-MX-12
	S-MX-2A	S-MX-3A	S-MX-5A	S-MX-8A	S-MX-12A
<b>HEIGHT</b>					
Stories (max)	2	3	5	8	12
<b>A</b> Feet (min/max)	na/30'	na/45'	24'/70'	24'/110'	24'/150'
Stories/Feet, with incentives (max)	na	4/55'	7/95'	12/150'	16/200'
Feet, within 175' of Protected District (max)	na	na	75'	na	na
<b>SITING</b>					
<b>REQUIRED BUILD TO</b>					
<b>B</b> Primary Street (min build-to % within min/max range)			75%		
	0'/5'		Residential Only Buildings: 0'/10'		
<b>C</b> Side Street (min build-to % within min/max range)			25%		
	0'/5'		Residential Only Buildings: 0'/10'		
<b>SETBACKS</b>					
Primary Street (min)			0'		
Side Street (min)			0'		
Side Interior (min)			0'		
<b>D</b> Side interior, adjacent to Protected District (min)			10'		
Rear (min)			0'		
Rear, adjacent to Protected District, where an Alley (public or private) abuts a Rear Zone Lot Line (min)			S-MX-2x: 12'	All Other Zone Districts: 0'	
Rear, adjacent to Protected District, where an Alley (public or private) does not abut a Rear Zone Lot Line (min)			S-MX-2x: 20'	All Other Zone Districts: 10'	
<b>PARKING</b>					
Surface Parking between building and Primary Street/Side Street			Not Allowed/Not Allowed See Section 3.3.5.1		
Vehicle Access, 3 or more side-by-side dwelling units in one structure			From Alley; or Street access allowed when no Alley present See Section 3.3.7.5		
Vehicle Access, all other permitted uses			Access determined at Site Development Plan Review		
<b>E</b> Surface Parking Screening			See Division 10.5, Landscaping, Fences, Walls and Screening		
<b>DESIGN ELEMENTS</b>					
<b>BUILDING CONFIGURATION</b>					
Primary Street Upper Story Setback above 5 stories or 70' (min) See Section 3.3.6.2 for Alternative	na	na	na	20'	20'
<b>F</b> Upper Story Setback above 27' adjacent to Protected District: Rear, alley/Rear, no alley and Side Interior (min)	na	15'/25'	20'/25'	20'/25'	20'/25'
<b>G</b> Upper story setback above 51' adjacent to Protected District: Rear, alley/no alley and Side Interior (min)	na	na	35'/40'	35'/40'	35'/40'
<b>STREET LEVEL ACTIVATION</b>					
<b>H</b> Transparency, Primary Street (min)			60%	Residential Only Buildings: 40%	
<b>I</b> Transparency, Side Street (min)			25%		
Transparency Alternatives			See Section 3.3.6.3		
<b>J</b> Pedestrian Access, Primary Street			Entrance		
<b>USES</b>					
All S-MS and S-MX Zone Districts					
(1) All permitted Primary Uses shall be allowed within this building form. See Division 3.4, Uses <b>and Required Minimum Parking</b> ; and (2) 100% of the portion of the Street Level building frontage that meets the minimum Primary Street and Side Street build-to requirements shall be occupied by Street Level active uses according to Section 3.3.5.3.					

See Sections 3.3.5 - 3.3.7 for Supplemental Design Standards, Design Standard Alternatives, and Design Standard Exceptions.

## DETACHED ACCESSORY DWELLING UNIT

	All S-SU			
	Option A: 1-story*	Option B: 2-stories*	All S-RH	All S-MU, CC, MX, MS
<b>HEIGHT</b>				
A Stories (max)	1	2	2	2
A Feet (max)	17'	24'	24'	24'
B Bulk Plane Vertical Height at Side Interior and Side Street Zone Lot Line	10'	10'	10'	na
C Bulk Plane Slope from Side Interior Zone Lot Line	45°	45°	45°	na

	All S-SU			
	Option A: 1-story*	Option B: 2-stories*	All S-RH	All S-MU, CC, MX, MS
<b>SITING</b>				
<b>SETBACKS</b>				
Location of Structure	Located in the rear 50% of the zone lot depth			
D Side Interior and Side Street for lots 25' wide or less (min)	3'	3'	3'	3'
D Side Interior and Side Street for lots greater than 25' wide and less than 62' wide (min)	5'	5'	5'	5'
D Side Interior and Side Street for lots 62' wide or greater (min)	7.5'	7.5'	5'	5'
E Rear (min)	10'	20'	5'	5'
Maximum Building Coverage	See maximum Building Coverage per Zone Lot in the Primary Structure building form table.			
<b>PARKING</b>				
Vehicle Access	From Alley; or Street access allowed when no Alley present See 3.3.7.6 for exceptions			

	All S-SU		
	Option A or B By Zone Lot Area		All S-RH, MU, CC, MX, MS
<b>DESIGN ELEMENTS</b>	7,000 sf or Less	Greater than 7,000 sf	
<b>BUILDING CONFIGURATION</b>			
Building Footprint (max)	864 sf per unit	1,000 sf per unit	1,000 sf per unit
Limitation on Gross Floor Area of the Accessory Dwelling Unit Use	See Section 11.8, Uses Accessory to Primary Residential Uses - Limitations		
Rooftop and/or Second Story Decks	Not allowed - See Section 3.3.5.2		

<b>USES</b>	All S-SU, RH, MU, CC, MX, MS
	An Accessory Dwelling Unit use must be concurrently permitted and approved for occupancy in this building form. The Accessory Dwelling Unit use may be combined with other uses Accessory to Primary Residential Uses. See Division 3.4, <b>Uses and Required Minimum Parking</b> , for permitted Uses Accessory to Primary Residential Uses.

See Sections 3.3.4.3 and 3.3.5 - 3.3.7 for Supplemental Design Standards, Design Standard Alternatives, and Design Standard Exceptions.  
\*Standards in the "Option A" column may not be combined with standards in the "Option B" column. For example, If using Option B height standards to construct a two-story structure, the structure must also follow the Option B siting standards that require a minimum 20' rear setback.

## GENERAL DETACHED STRUCTURE

Examples of General Detached Structures include garages, sheds, and gazebos. The General Detached Structure building form provides standards for structures accessory to a primary structure that exceed the standards for a Minor Detached Structure building form.

HEIGHT		All S-SU	S-RH-2.5	All S-MU	All S-CC,-MX, -MS
A	Stories (max)	1	1	1	1
A	Feet (max)	17'	17'	17'	17'
B	Bulk Plane Vertical Height at Side Interior and Side Street Zone Lot Line	10'	10'	na	na
	Bulk Plane Slope from Side Interior and Side Street Zone Lot Line	45°	45°	na	na

SITING		All S-SU	S-RH-2.5	All S-MU	All S-CC,-MX, -MS
Additional Standards		See Section 3.3.4.3, Supplemental Standards			

SETBACKS AND BUILDING COVERAGE					
C	Location of Structure	Located a minimum of 10' behind 75% of the total width of the Primary Street-facing Façade(s) of one Primary Structure; see Section 13.1.5.12 for applicable location standard when there are multiple Primary Structures on one Zone Lot			
D	Side Street (min)	5'	5'	5'	5'
	Side Interior (min), for structure entirely in rear 35% of zone lot	0'	0'	0'	5'
D	Side Interior (min), for structure not entirely in rear 35% of zone lot	5'	5'	5'	5'
	Side Interior (min), for structure not entirely in rear 35% of zone lot, where Zone Lot Width is 30' or less	3'	3'	3'	5'
E	Rear, where no Alley (public or private) abuts a Rear Zone Lot Line (min)	5'	5'	5'	5'
	Rear, where Alley (public or private) abuts a Rear Zone Lot Line and where garage doors face Alley (min)**	5'	5'	5'	5'
	Rear, where Alley (public or private) abuts a Rear Zone Lot Line, and where garage doors do not face Alley (min)	0'	0'	0'	0'
	Building Coverage (max)	See maximum Building Coverage per Zone Lot in the Primary Structure building form table.			

PARKING						
	Vehicle Access	From Alley; or Street access allowed when no Alley present See Section 3.3.7.5 for exceptions			See Section 10.4.6, Vehicle Parking Design for standards	

DESIGN ELEMENTS		All S-SU	S-RH-2.5	All S-MU	All S-CC,-MX, -MS
BUILDING CONFIGURATION					
	Building Footprint (max)	1,000 sf per unit	1,000 sf per unit	1,000 sf per unit	na
	Gross Floor Area (max)	na	na	na	See Sec. 3.3.4.3.C
F	Overall Structure Length (max)	36' per unit	no max	no max	na
	Allowed Number of Primary Street Facing Vehicular Access Doors in the front 50% of the lot depth (max)	3	no max	no max	na
G	Cumulative Width of All Primary Street Facing Vehicular Access Doors in the front 50% of the lot depth (max)	28'	no max	no max	na

USES		All S-SU; S-RH-2.5; All S-MU	All S-CC,-MX, -MS
		Accessory Uses Only, excluding accessory dwelling unit where permitted. See Division 3.4, Uses and Required Minimum Parking.	

See Sections 3.3.5 - 3.3.7 for Supplemental Design Standards, Design Standard Alternatives, and Design Standard Exceptions.  
See Section 10.4.6 Vehicle Parking Design for standards that may be more restrictive.

## MINOR DETACHED STRUCTURES

Structures that meet the standards in this building form table are exempt from the requirement to obtain a zoning permit. Examples of Minor Detached Structures include sheds, arbors, play structures, ground-mounted mechanical equipment such as air conditioning units and heat pumps, and other structures that are similarly minor in impact, height, and footprint. Option A is more limited than Option B in height and footprint, but offers more flexibility in siting. Structures that do not meet the standards in the table below shall be reviewed under the General Detached Structure building form.

		All S-SU, RH, MU, CC, MX, MS Districts	
<b>HEIGHT</b>		Option A*	Option B
A	Stories (max)	1	1
A	Feet (max)	4'	14'

		Option A	Option B
<b>SITING</b>			
Total number of each structure (max)		na	na
<b>LOCATION OF STRUCTURE</b>			
Ground-Mounted Mechanical Equipment	Shall be located a minimum of 10' behind 75% of the total width of the Primary Street-facing Façade**		Shall be located a minimum of 10' behind 75% of the total width of the Primary Street-facing Façade**
Public Utility Equipment	Allowed anywhere on the Zone Lot		
All Others	Allowed anywhere on the Zone Lot		
<b>SETBACKS</b>			
B	Side Street (min)	5'	5'
C	Side Interior, for structure entirely in rear 35% of zone lot (min)	0'	0'
	Side Interior, for structure not entirely in rear 35% of zone lot (min)	5'	5'
	Rear, where no Alley (public or private) abuts Rear Zone Lot Line (min)	5'	5'
D	Rear, where Alley (public or private) abuts Rear Zone Lot Line (min)	0'	0'
Building Coverage per Zone Lot (max)		See maximum Building Coverage per Zone Lot in the Primary Structure building form table.	

		All S-SU, RH, MU, CC, MX, MS Districts	
<b>DESIGN ELEMENTS</b>		Option A	Option B
<b>BUILDING CONFIGURATION</b>			
Structure footprint (max)		12 sf	200 sf

		All S-SU, RH, MU, CC, MX, MS Districts
<b>USES</b>		Accessory Uses Only, excluding accessory dwelling unit use and parking and storage of vehicles. See Division 3.4, Uses <del>and Required Minimum Parking</del> , for permitted Accessory Uses.

See Sections 3.3.5 - 3.3.7 for Supplemental Design Standards, Design Standard Alternatives, and Design Standard Exceptions.

\* Standards in the "Option A" column may not be combined with standards in the "Option B" column. For example, If using Option B height standards to construct a 14-foot-tall structure, the structure must also follow the Option B siting standards that require the structure to be located a minimum of 10 feet behind 75% of the Primary Street-facing Façade.

\*\*When there are multiple Primary Structures on one Zone Lot, all Minor Detached Structures shall be located behind 75% of the total width of the Primary Street-facing Façade(s) of at least one Primary Structure. See Section 13.1.5.12.C, Rule of Measurement for Multiple Primary Structures on One Zone Lot, for applicable location standard when there are multiple Primary Structures on one Zone Lot.

BUILDING FEATURES	ZONE DISTRICTS	THE AGGREGATE SHALL NOT EXCEED 33-1/3 PERCENT OF THE AREA OF THE SUPPORTING ROOF	SHALL BE SET BACK FROM THE PERIMETER OF THE BUILDING A MINIMUM OF ONE FOOT HORIZONTALLY FOR EVERY ONE FOOT OF VERTICAL HEIGHT	MAY EXCEED MAXIMUM HEIGHT IN FEET BY:	MAY EXCEED MAXIMUM HEIGHT IN STORIES BY:	MAY PROJECT THROUGH THE BULK PLANE	MAY EXCEED UPPER STORY SETBACK HEIGHT BY
Solar panels	All S- Zone Districts	No	No	Any distance	Not applicable	Any distance	Any distance
Evaporative coolers	All S- Zone Districts	No	Yes	Any distance	Not applicable	Any distance	Any distance
Accessory water tanks	All S-CC, S-MX, S-MS Zone Districts	No	Yes	28'	Not applicable	Any distance	Any distance
Pedestrian bridge	All S- Zone Districts	Not applicable	Not applicable	28'	Any number	Any distance	Any distance

### 3.3.7.2 Required Build-To Exception for Civic, Public & Institutional Uses

#### A. Intent

To accommodate signature entrance architecture, gathering spaces, plazas, or community amenities along the front Façades of structures containing civic, public and institutional uses.

#### B. Standard

Structures containing one or more uses in the Civic, Public & Institutional Use Classification are not required to meet the Primary Street and Side Street Build-To standards.

### 3.3.7.3 Setback Exceptions - Architectural, Site, Service & Utility Elements

#### A. Intent

To allow minor elements to encroach into a setback while maintaining an open and unobstructed minimum setback.

#### B. Standard

Except as specifically allowed below, Setbacks specified in the applicable Building Form tables shall be open and unobstructed.

#### C. Exceptions

The following Structures or portions of Structures are permitted to encroach into the Setbacks subject to the limitations in the tables below. No portion of a Structure that encroaches into the Setbacks shall extend into a required Setback beyond the maximum Setback encroachment distance specified in the tables below, as measured perpendicular to the respective Zone Lot line. Where more than one Setback encroachment is allowed for the same Structure or portion of a Structure, the permitted Setback encroachment distances shall not be cumulative. See "Height Exceptions" for encroachments related to Upper Story Setbacks.

##### 1. Architectural Elements

To allow for minor elements which add to the architectural character of buildings, while maintaining an open and unobstructed setback.

	ZONE DISTRICTS	BUILDING FORMS	PRIMARY STREET	SIDE STREET	SIDE INTERIOR	REAR
Fences and Walls	See Division 10.5 Landscaping, Fences, Walls and Screening					
	ZONE DISTRICTS	BUILDING FORMS	PRIMARY STREET	SIDE STREET	SIDE INTERIOR	REAR
Off-Street Parking Area	All S-SU, S-RH, S-MU Zone Districts	Suburban House, Duplex, and Tandem House	Any distance	Any distance	Any distance	Any distance
Intent: To allow off-street parking where it is <b>not less</b> impactful <b>due to the number of required provided parking spaces</b> .	<p>The diagram shows a lot layout with an alley and a side street. It illustrates setbacks for the rear, primary street, and side street. Encroachments are shown for the rear and side street. Labels include: Side Setback, Rear Setback, Primary Street Setback, Allowed Encroachment, ALLEY, SIDE STREET, and PRIMARY STREET. A note at the bottom right says 'Not to Scale. Illustrative Only.'</p>					
<p><i>Illustrative only</i></p>						
	ZONE DISTRICTS	BUILDING FORMS	PRIMARY STREET	SIDE STREET	SIDE INTERIOR	REAR
Off-Street Parking Area	All S-RH and S-MU Zone Districts	Row House and Apartment	Not allowed	Not allowed	Allowed within the rear 35% of the Zone Lot only	Any distance
Intent: To restrict off-street parking where it is <b>more</b> impactful <b>due to the number of required provided parking spaces</b> .	<p>The diagram shows a lot layout with a side street and a rear setback. It illustrates setbacks for the rear, primary street, and side street. Encroachments are shown for the rear and side street. Labels include: REAR, Rear Setback, Side Setback, Primary Street Setback, Allowed Encroachment, SIDE STREET, and PRIMARY STREET. A note at the bottom right says 'Not to Scale. Illustrative Only.'</p>					

## DIVISION 3.4 USES ~~AND REQUIRED MINIMUM PARKING~~

### SECTION 3.4.1 APPLICABILITY

- 3.4.1.1 This Division 3.4 sets forth the land uses permitted; ~~and the~~ required zoning procedures ~~and the required minimum parking~~ for all the Suburban Neighborhood Context zone districts.
- 3.4.1.2 Uses not listed are prohibited, unless the Zoning Administrator specifically permits the unlisted use according to Section 12.4.6, Code Interpretations and Determination of Unlisted Uses.
- 3.4.1.3 For number of primary and accessory uses allowed per Zone Lot, see Section 1.2.3.5, Number of Structures and Uses Allowed per Zone Lot.

### SECTION 3.4.2 ORGANIZATION

#### 3.4.2.1 Organized by Primary, Accessory and Temporary Uses

The Use ~~and Parking~~ Table first presents all primary uses, then all accessory uses, and finally all temporary uses. Primary uses are arranged hierarchically within the table by use classification, category of primary uses, and then by specific use type. Accessory uses are organized by whether such use is accessory to a primary residential use or to a primary nonresidential use. Temporary uses are presented alphabetically ordered in the last division of the table.

#### 3.4.2.2 Primary Use Classifications, Categories & Specific Use Types

##### A. Primary Use Classifications

All primary land uses in the Use ~~and Parking~~ Table are organized into one of the following five general land use classifications:

1. Residential Uses
2. Civic, Public & Institutional Uses
3. Commercial Sales, Service & Repair Uses
4. Industrial, Manufacturing & Wholesale Uses
5. Agriculture

##### B. Primary Use Categories & Specific Use Types

Primary uses are further organized into use categories and specific use types listed under each general primary land use classification. The Use ~~and Parking~~ Table is organized into the above five general land use classifications, use categories, and specific use types.

##### C. Classifications & Categories Are Mutually Exclusive

The general land use classifications and use categories listed in the Use ~~and Parking~~ Table are intended to be mutually exclusive; that is, a use classified into one use category, such as “lodging accommodations,” cannot be classified in a different use category, such as “congregate living,” unless otherwise expressly permitted by this Code.

### SECTION 3.4.3 EXPLANATION OF TABLE ABBREVIATIONS

#### 3.4.3.1 General Explanation of Table Cell Entries

In each of the table cells, the entry will indicate first whether use limitations apply to the specific use, and then separated by a hyphen, the type of zoning review required prior to establishment of the use under this Code. For example, as described in more detail below, a cell entry “L-ZPIN” means, first, the use is subject to use limitations (the “L”), and, second, that the use is subject to zoning permit review with information notice (the “ZPIN”) prior to its establishment.

### 3.4.3.2 Permitted, Limited, Not Permitted

#### A. Permitted Use - No Use Limitations Apply (“P”)

A “P” in a table cell indicates that the use is permitted in the respective zone district, and is not subject to use limitations.

#### B. Permitted Use - Subject to Use Limitations (“L”)

“L” in a table cell indicates the use is permitted in the zone district subject to compliance with the use limitations referenced in the last column of the use table (“Applicable Use Limitations”).

#### C. Uses Not Permitted (“NP”)

“NP” in a table cell indicates that the use is not permitted in the specific zone district.

### 3.4.3.3 Zoning Procedure

#### A. Use Subject to Zoning Permit Review (“ZP”)

“ZP” in a table cell indicates that the use is permitted in the respective zone district only if reviewed and approved according to the requirements in Section 12.4.1, Zoning Permit Review.

#### B. Use Subject to Zoning Permit Review with Informational Notice (“ZPIN”)

“ZPIN” in a table cell indicates that the use is permitted in the respective zone district only if reviewed and approved according to the public notice and procedural requirements in Section 12.4.2, Zoning Permit Review with Informational Notice. Such uses shall comply with any applicable use limitations noted in the last column of the use table (“Applicable Use Limitations”), as well as the review criteria stated in Section 12.4.2, Zoning Permit Review with Informational Notice.

#### C. Use Subject to Zoning Permit Review with Community Information Meeting (“ZPCIM”)

“ZPCIM” in a table cell indicates that the use is permitted in the respective zone district only if reviewed and approved according to the public notice and procedural requirements in Section 12.4.1, Zoning Permit Review. Prior to formal application, an applicant shall schedule a community information meeting and provide public notice of the community information meeting according to Section 12.3.4.6, Community Information Meeting.

#### D. Use Subject to Zoning Permit with Special Exception Review (“ZPSE”)

“ZPSE” in a table cell indicates that use is generally appropriate in the neighborhood context and zone district, yet may have the potential for limited impacts on adjacent properties or on the established character of the neighborhood context or zone district. “ZPSE” uses are subject to a Board of Adjustments public hearing according to Section 12.4.9, Zoning Permit with Special Exception Review, which grants the Board of Adjustment the authority to impose conditions on the specified use to mitigate any potential impacts. Such uses shall comply with any applicable use limitations noted in the last column of the use table (“Applicable Use Limitations”), as well as the review criteria stated in Section 12.4.9, Zoning Permit with Special Exception Review.

#### E. Uses Where More Than One Zoning Procedure Is Indicated

Where a table cell shows more than one zoning procedure applies to a use, for example “L-ZP/ZPIN”, the referenced use limitation (last table column) will indicate which zoning procedure applies in a specific case. For example, a table cell may indicate “L-ZPIN/ZPSE” for a use. This means that the ZPIN zoning procedure will apply, unless the applicable use limitation specifies the ZPSE zoning procedure is triggered (e.g., by proximity to a Protected District).

### 3.4.3.4 Enclosure of Uses

All primary, accessory and temporary uses must be established, operated and maintained within a Completely Enclosed Structure, unless otherwise specifically allowed by this Code. The Use ~~and Parking~~ Tables in Articles 3-9 indicate when a use may be established, operated or maintained outside a Completely Enclosed Structure by including an asterisk “\*” next to the specific use type. For example, the asterisk following the “Telecommunication Tower\*” use type in the tables indicates that a telecommunication tower land use need not be enclosed.



### SECTION 3.4.4 DISTRICT SPECIFIC STANDARDS

KEY: \* = Need Not be Enclosed P = Permitted Use without Limitations L = Permitted Use with Limitations NP = Not Permitted Use ZP = Zoning Permit Review  
ZPCIM = Subject to Zoning Permit Review with Community Information Meeting ZPIN = Subject to Zoning Permit Review with Informational Notice  
ZPSE = Subject to Zoning Permit with Special Exception Review When no ZP, ZPCIM, ZPIN, ZPSE listed = No Zoning Permit required

USE CATEGORY	SPECIFIC USE TYPE • Vehicle Parking Reqmt: # spaces per unit of measurement • Bicycle Parking Reqmt Requirement: # spaces per unit of measurement (% Required Spaces in Enclosed Facility / % Required Spaces in Fixed Facility)	S-SU-A S-SU-D S-SU-F S-SU-Fx S-SU-Ix	S-SU-FA S-SU-I	S-RH-2.5	S-MU-3 S-MU-5 S-MU-8 S-MU-12 S-MU-20	S-CC-3x S-CC-5x	S-CC-3 S-CC-5	S-MX-2x	S-MX-2 S-MX-2A	S-MX-3 S-MX-3A S-MX-5 S-MX-5A S-MX-8 S-MX-8A S-MX-12 S-MX-12A	S-MS-3 S-MS-5	APPLICABLE USE LIMITATIONS
<b>RESIDENTIAL PRIMARY USE CLASSIFICATION</b>												
Household Living	Dwelling, Single Unit • Bicycle: No Parking Requirements	L-ZP	L-ZP	L-ZP	L-ZP	L-ZP	L-ZP	L-ZP	L-ZP	L-ZP	L-ZP	\$11.2.7
	Dwelling, Two Unit • Vehicle: 1.25/unit • MS only: 1/unit • Bicycle: No requirement	L-ZP	L-ZP	L-ZP	L-ZP	L-ZP	L-ZP	L-ZP	L-ZP	L-ZP	L-ZP	\$11.2.2; \$11.2.7
	Dwelling, Multi-Unit • Vehicle – MS only: 1/unit • Vehicle: 1.25/unit • Bicycle: 1/5 units (80/20)	L-ZP	L-ZP	L-ZP	L-ZP	L-ZP	L-ZP	L-ZP	L-ZP	L-ZP	L-ZP	\$11.2.3; \$11.2.7
	Dwelling, Live / Work • Vehicle – MS only: 1/unit • Vehicle: 1.25/unit • Bicycle: 1/5 units (80/20)	NP	NP	NP	NP	L-ZP	L-ZP	L-ZP	L-ZP	L-ZP	L-ZP	\$11.2.4; \$11.2.7
	Manufactured Home Community	NP	NP	NP	NP	NP	NP	NP	NP	NP	NP	
Residential Care	Residential Care, Type 1 • Vehicle: .5/1,000 sf GFA • Bicycle: No requirement	L/L-ZP	L/L-ZP	L/L-ZP	L/L-ZP	L/L-ZP	L/L-ZP	L/L-ZP	L/L-ZP	L/L-ZP	L/L-ZP	\$11.2.8; \$11.2.9
	Residential Care, Type 2 • Vehicle: .5/1,000 sf GFA • Bicycle: No requirement	L-ZPCIM	L-ZPCIM	L-ZPCIM	L-ZP	L-ZP	L-ZP	L-ZP	L-ZP	L-ZP	L-ZP	\$11.2.8; \$11.2.10
	Residential Care, Type 3 • Vehicle: .5/1,000 sf GFA • Bicycle: No requirement	NP	NP	NP	S-MU-3, -5: NP S-MU-8, -12, -20: L-ZPCIM	L-ZPCIM	L-ZPCIM	NP	NP	L-ZPCIM	L-ZPCIM	\$11.2.8; \$11.2.11
	Residential Care, Type 4 • Vehicle: .5/1,000 sf GFA • Bicycle: No requirement	NP	NP	NP	S-MU-3, -5: NP S-MU-8, -12, -20: L-ZPCIM	L-ZPCIM	L-ZPCIM	NP	NP	L-ZPCIM	L-ZPCIM	\$11.2.8; \$11.2.12
Congregate Living	All Types • Vehicle: 1/1,000 sf GFA • Bicycle: 1/20,000 sf GFA	NP	NP	NP	P-ZP	P-ZP	P-ZP	P-ZP	P-ZP	P-ZP	P-ZP	
<b>CIVIC, PUBLIC &amp; INSTITUTIONAL PRIMARY USE CLASSIFICATION</b>												
Basic Utilities	Utility, Major Impact* • Vehicle: .5/1,000 sf GFA • Bicycle: No requirement	L-ZPSE	L-ZPSE	L-ZPSE	L-ZPSE	L-ZPSE	L-ZPSE	L-ZPSE	L-ZPSE	L-ZPSE	L-ZPSE	\$11.3.1
	Utility, Minor Impact* • Vehicle: .5/1,000 sf GFA • Bicycle: No requirement	L-ZP	L-ZP	L-ZP	L-ZP	L-ZP	L-ZP	L-ZP	L-ZP	L-ZP	L-ZP	\$11.3.2

**Modernizing Parking Requirements**  
**LUTI Committee Review Draft**  
**May 13, 2025**

Article 3. Suburban Neighborhood Context  
 Division 3.4 Uses ~~and Required Minimum Parking~~

KEY: \* = Need Not be Enclosed P = Permitted Use without Limitations L = Permitted Use with Limitations NP = Not Permitted Use ZP = Zoning Permit Review  
 ZPCIM = Subject to Zoning Permit Review with Community Information Meeting ZPIN = Subject to Zoning Permit Review with Informational Notice  
 ZPSE = Subject to Zoning Permit with Special Exception Review When no ZP, ZPCIM, ZPIN, ZPSE listed = No Zoning Permit required

USE CATEGORY	SPECIFIC USE TYPE <ul style="list-style-type: none"> <li>• <del>Vehicle Parking Reqmt: # spaces per unit of measurement</del></li> <li>• <del>Bicycle Parking Reqmt Requirement: # spaces per unit of measurement (% Required Spaces in Enclosed Facility / % Required Spaces in Fixed Facility)</del></li> </ul>	<div style="display: flex; justify-content: space-between; font-size: 0.8em;"> <div>S-SU-A S-SU-D S-SU-F S-SU-FA S-SU-I</div> <div>S-RH-2.5</div> <div>S-MU-3 S-MU-5 S-MU-8 S-MU-12 S-MU-20</div> <div>S-CC-3x S-CC-5x</div> <div>S-CC-3 S-CC-5</div> <div>S-MX-2 S-MX-2A</div> <div>S-MX-3 S-MX-3A S-MX-5 S-MX-5A S-MX-8 S-MX-8A S-MX-12 S-MX-12A</div> <div>S-MS-3 S-MS-5</div> </div>										APPLICABLE USE LIMITATIONS
		Community/ Public Services	Community Center* • <del>Vehicle: .5 / 1,000 sf GFA</del> • <del>Bicycle: 1 / 10,000 sf GFA (0/100)</del>	L-ZP	L-ZP	L-ZP	L-ZP	L-ZP	L-ZP	L-ZP	L-ZP	
	Day Care Center • <del>Vehicle: 1 / 1,000 sf GFA</del> • <del>Bicycle: 1 / 10,000 sf GFA (0/100)</del>	L-ZP	L-ZP	P-ZPIN	P-ZP	P-ZP	P-ZP	P-ZPIN	P-ZP	P-ZP	P-ZP	§11.3.4
	Postal Facility, Neighborhood • <del>Vehicle - MS only: 2 / 1,000 sf GFA</del> • <del>Vehicle: 2.5 / 1,000 sf GFA</del> • <del>Bicycle: 1 / 20,000 sf GFA (20/80)</del>	P-ZP	P-ZP	P-ZP	P-ZP	P-ZP	P-ZP	P-ZP	P-ZP	P-ZP	P-ZP	
	Postal Processing Center • <del>Vehicle: 1 / 1,000 sf GFA</del> • <del>Bicycle: 1 / 20,000 sf GFA (20/80)</del>	NP	NP	NP	NP	P-ZP	P-ZP	NP	NP	P-ZP	P-ZP	
	Public Safety Facility • <del>Vehicle: 1 / 1,000 sf GFA</del> • <del>Bicycle: 1 / 10,000 sf GFA (0/100)</del>	L-ZP	L-ZP	L-ZP	L-ZP	P-ZP	P-ZP	P-ZP	P-ZP	P-ZP	P-ZP	§11.3.5
	Hospital	NP	NP	NP	NP	NP	NP	NP	NP	NP	NP	
	Correctional Institution	NP	NP	NP	NP	NP	NP	NP	NP	NP	NP	
Cultural/ Special Purpose/ Public Parks & Open Space	Cemetery*	NP	NP	NP	NP	NP	NP	NP	NP	NP	NP	
	Library • <del>Vehicle: 1 / 1,000 sf GFA</del> • <del>Bicycle: 1 / 10,000 sf GFA (0/100)</del>	P-ZP	P-ZP	P-ZP	P-ZP	P-ZP	P-ZP	P-ZP	P-ZP	P-ZP	P-ZP	
	Museum • <del>Vehicle: 1 / 1,000 sf GFA</del> • <del>Bicycle: 1 / 10,000 sf GFA (0/100)</del>	NP	NP	NP	NP	P-ZP	P-ZP	P-ZP	P-ZP	P-ZP	P-ZP	
	City Park*	NP	NP	NP	NP	NP	NP	NP	NP	NP	NP	
	Open Space - Conservation* • <del>No Parking Requirements</del>	P-ZP	P-ZP	P-ZP	P-ZP	P-ZP	P-ZP	P-ZP	P-ZP	P-ZP	P-ZP	
Education	Elementary or Secondary School • <del>Vehicle - High School: 2 / 1,000 sf GFA</del> • <del>Bicycle: - High School: 1 / 20,000 sf GFA (0/100)</del> • <del>Vehicle - All Others: 1 / 1,000 sf GFA</del> • <del>Bicycle: - All Others: 1 / 10,000 sf GFA (0/100)</del>	L-ZP	L-ZP	L-ZP	L-ZP	L-ZP	L-ZP	L-ZP	L-ZP	L-ZP	L-ZP	§11.3.8
	University or College • <del>Vehicle: 1 / 1,000 sf GFA</del> • <del>Bicycle: 1 / 10,000 sf GFA (0/100)</del>	NP	NP	NP	L-ZP	L-ZP	L-ZP	NP	L-ZP	L-ZP	L-ZP	§11.3.8; § 11.3.9
	Vocational or Professional School • <del>Vehicle: 1 / 1,000 sf GFA</del> • <del>Bicycle: 1 / 10,000 sf GFA (0/100)</del>	NP	NP	NP	NP	L-ZP	L-ZP	L-ZP	L-ZP	L-ZP	L-ZP	§11.3.8
Public and Religious Assembly	All Types • <del>Vehicle: .5 / 1,000 sf GFA</del> • <del>Bicycle: 1 / 10,000 sf GFA (0/100)</del>	L-ZP	L-ZP	L-ZP	L-ZP	P-ZP	P-ZP	L-ZP	P-ZP	P-ZP	P-ZP	§ 11.3.10
COMMERCIAL SALES, SERVICES, & REPAIR PRIMARY USE CLASSIFICATION												

KEY: \* = Need Not be Enclosed P = Permitted Use without Limitations L = Permitted Use with Limitations NP = Not Permitted Use ZP = Zoning Permit Review  
ZPCIM = Subject to Zoning Permit Review with Community Information Meeting ZPIN = Subject to Zoning Permit Review with Informational Notice  
ZPSE = Subject to Zoning Permit with Special Exception Review When no ZP, ZPCIM, ZPIN, ZPSE listed = No Zoning Permit required

USE CATEGORY	SPECIFIC USE TYPE <i>• Vehicle Parking Reqmt: # spaces per unit of measurement • Bicycle Parking Reqmt Requirement: # spaces per unit of measurement (% Required Spaces in Enclosed Facility / % Required Spaces in Fixed Facility)</i>	ZONING DISTRICTS											APPLICABLE USE LIMITATIONS	
		S-SU-Fx S-SU-Ix	S-SU-A S-SU-D S-SU-F S-SU-FA S-SU-I	S-RH-2.5	S-MU-3 S-MU-5 S-MU-8 S-MU-12 S-MU-20	S-CC-3x S-CC-5x	S-CC-3 S-CC-5	S-MX-2x S-MX-2A	S-MX-3 S-MX-3A S-MX-5 S-MX-5A S-MX-8 S-MX-8A S-MX-12 S-MX-12A	S-MS-3 S-MS-5				
Adult Business	All Types	NP	NP	NP	NP	NP	NP	NP	NP	NP	NP	NP	NP	See Section 9.4.4, Use Overlay Districts, for adult business use allowance in the UO-1 District.
Arts, Recreation, & Entertainment	Arts, Recreation, and Entertainment Services, Indoor <i>• Vehicle - Artist Studio: 0.3/1000 sf GFA • Vehicle - All Others - MS only: 2/1,000 sf GFA • Vehicle - All Others: 2.5/1,000 sf GFA • Bicycle: 1/20,000 sf GFA (20/80)</i>	NP	NP	NP	NP	P-ZP	P-ZP	L-ZPIN	L-ZP	P-ZP	P-ZP	P-ZP	\$ 11.4.2	
	Arts, Recreation, and Entertainment Services, Outdoor* <i>• Vehicle - MS only: 2/1,000 sf GFA • Vehicle: 2.5/1,000 sf GFA • Bicycle: 1/20,000 sf GFA (20/80)</i>	NP	NP	NP	NP	L-ZPSE	L-ZP	NP	L-ZPSE	L-ZPSE	L-ZPSE	L-ZPSE	\$ 11.4.3	
	Event Space with Alternate Parking and Loading* <i>• Vehicle: No requirement • Bicycle: No requirement</i>	NP	NP	NP	NP	NP	NP	NP	NP	NP	NP	NP	NP	
	Sports and/or Entertainment Arena or Stadium*	NP	NP	NP	NP	NP	NP	NP	NP	NP	NP	NP	NP	
Nonresidential Uses in Existing Business Structures In Residential Zones <i>(All Uses Shall Be Parked According to the Parking Requirement Stated in this Use Table for the Specific Nonresidential Use)</i>		L-ZP	L-ZP	L-ZP	L-ZP	Not Applicable							\$11.4.6	
Parking of Vehicles	Parking, Garage <i>• No Parking Requirements</i>	NP	NP	NP	P-ZP	P-ZP	P-ZP	NP	P-ZP	P-ZP	P-ZP	P-ZP		
	Parking, Surface* <i>• No Parking Requirements</i>	NP	NP	L-ZP	L-ZP	P-ZP	P-ZP	NP	NP	NP	NP	NP	\$ 11.4.8	
Eating & Drinking Establishments	All Types <i>• Vehicle - MS only: 2/1,000 sf GFA • Vehicle: 5/1,000 sf GFA • Bicycle: 1/5,000 sf GFA (0/100)</i>	NP	NP	NP	NP	P-ZP	P-ZP	L-ZPSE	L-ZP	P-ZP	P-ZP	P-ZP	\$ 11.4.9	
Lodging Accommodations	Bed and Breakfast Lodging <i>• Vehicle: 1/guest room or unit • Bicycle: 1/20,000 sf GFA (60/40)</i>	NP	NP	NP	NP	P-ZP	P-ZP	NP	P-ZP	P-ZP	P-ZP	P-ZP		
	Lodging Accommodations, All Others <i>• Vehicle: 1/guest room or unit • Bicycle: 1/20,000 sf GFA (60/40)</i>	NP	NP	NP	NP	P-ZP	P-ZP	NP	NP	P-ZP	P-ZP	P-ZP		

**Modernizing Parking Requirements  
LUTI Committee Review Draft  
May 13, 2025**

Article 3. Suburban Neighborhood Context  
Division 3.4 Uses ~~and Required Minimum Parking~~

KEY: \* = Need Not be Enclosed P = Permitted Use without Limitations L = Permitted Use with Limitations NP = Not Permitted Use ZP = Zoning Permit Review  
ZPCIM = Subject to Zoning Permit Review with Community Information Meeting ZPIN = Subject to Zoning Permit Review with Informational Notice  
ZPSE = Subject to Zoning Permit with Special Exception Review When no ZP, ZPCIM, ZPIN, ZPSE listed = No Zoning Permit required

USE CATEGORY	SPECIFIC USE TYPE <i>• Vehicle Parking Reqmt: # spaces per unit of measurement • Bicycle Parking Reqmt Requirement: # spaces per unit of measurement (% Required Spaces in Enclosed Facility) / % Required Spaces in Fixed Facility)</i>											APPLICABLE USE LIMITATIONS
		S-SU-Fx S-SU-Ix	S-SU-A S-SU-D S-SU-F S-SU-FA S-SU-I	S-RH-2.5	S-MU-3 S-MU-5 S-MU-8 S-MU-12 S-MU-20	S-CC-3x S-CC-5x	S-CC-3 S-CC-5	S-MX-2x S-MX-2A	S-MX-3 S-MX-3A S-MX-5 S-MX-5A S-MX-8 S-MX-8A S-MX-12 S-MX-12A	S-MS-3 S-MS-5		
Office	Dental / Medical Office or Clinic <i>• Vehicle: 2/1,000 sf GFA • Bicycle: 1/20,000 sf GFA (60/40)</i>	NP	NP	NP	NP	L-ZP	L-ZP	L-ZP	L-ZP	L-ZP	L-ZP	\$11.4.10
	Office, All Others <i>• Vehicle: 2/ 1,000 sf GFA • Bicycle: 1/20,000 sf GFA (60/40)</i>	NP	NP	NP	NP	P-ZP	P-ZP	P-ZP	P-ZP	P-ZP	P-ZP	
Retail Sales, Service & Repair (Not Including Vehicle or Equipment Sales, Service & Repair)	Animal Sales and Services, Household Pets Only <i>• Vehicle: MS only: 2/1,000 sf GFA • Vehicle: 2.5/1,000 sf GFA • Bicycle: 1/20,000 sf GFA (20/80)</i>	NP	NP	NP	NP	L-ZP	L-ZP	L-ZPIN	L-ZP	L-ZP	L-ZP	\$11.4.12; \$11.4.13
	Animal Sales and Services, All Others	NP	NP	NP	NP	NP	NP	NP	NP	NP	NP	
	Food Sales or Market <i>• Vehicle: MS only: 2/1,000 sf GFA • Vehicle: 2.5/1,000 sf GFA • Bicycle: 1/20,000 sf GFA (20/80)</i>	NP	NP	NP	NP	P-ZP	P-ZP	L-ZP	L-ZP	P-ZP	P-ZP	\$11.4.14
	Pawn Shop	NP	NP	NP	NP	NP	NP	NP	NP	NP	NP	
	Retail Sales, Service & Repair -- Outdoor* <i>• Vehicle: MS only: 2/1,000 sf GFA • Vehicle: 2.5/1,000 sf GFA • Bicycle: 1/20,000 sf GFA (20/80)</i>	NP	NP	NP	NP	NP	L-ZP	L-ZPIN	L-ZPIN	NP	NP	\$11.4.11 \$11.4.16
	Retail Sales, Service & Repair - Firearms Sales <i>• Vehicle: MS only: 2/1,000 sf GFA • Vehicle: 2.5/1,000 sf GFA • Bicycle: 1/20,000 sf GFA (20/80)</i>	NP	NP	NP	NP	NP	P-ZP	NP	NP	NP	P-ZP	
	Retail Sales, Service & Repair, All Others <i>• Vehicle: MS only: 2/1,000 sf GFA • Vehicle: 2.5/1,000 sf GFA • Bicycle: 1/20,000 sf GFA (20/80)</i>	NP	NP	NP	NP	P-ZP	P-ZP	L-ZP/L-ZPIN	L-ZP	P-ZP	P-ZP	\$11.4.11

KEY: \* = Need Not be Enclosed P = Permitted Use without Limitations L = Permitted Use with Limitations NP = Not Permitted Use ZP = Zoning Permit Review  
ZPCIM = Subject to Zoning Permit Review with Community Information Meeting ZPIN = Subject to Zoning Permit Review with Informational Notice  
ZPSE = Subject to Zoning Permit with Special Exception Review When no ZP, ZPCIM, ZPIN, ZPSE listed = No Zoning Permit required

USE CATEGORY	SPECIFIC USE TYPE • Vehicle Parking Reqmt: # spaces per unit of measurement • Bicycle Parking Reqmt Requirement: # spaces per unit of measurement (% Required Spaces in Enclosed Facility) / (% Required Spaces in Fixed Facility)											APPLICABLE USE LIMITATIONS	
		S-SU-Fx S-SU-Ix	S-SU-A S-SU-D S-SU-F S-SU-FA S-SU-I	S-RH-2.5	S-MU-3 S-MU-5 S-MU-8 S-MU-12 S-MU-20	S-CC-3x S-CC-5x	S-CC-3 S-CC-5	S-MX-2x	S-MX-2 S-MX-2A	S-MX-3 S-MX-3A S-MX-5 S-MX-5A S-MX-8 S-MX-8A S-MX-12 S-MX-12A	S-MS-3 S-MS-5		
Vehicle / Equipment Sales, Rentals, Service & Repair	Automobile Emissions Inspection Facility • Vehicle: .5/1,000 sf GFA • Bicycle: No requirement	NP	NP	NP	NP	P-ZP	P-ZP	NP	L-ZP	P-ZP	P-ZP	\$11.4.17	
	Automobile Services, Light • Vehicle: .5/1,000 sf GFA • Bicycle: No requirement	NP	NP	NP	NP	L-ZP	L-ZP	NP	L-ZPSE	L-ZP	L-ZP	\$11.4.18; \$11.4.19	
	Automobile Services, Heavy • Vehicle: .5/1,000 sf GFA • Bicycle: No requirement	NP	NP	NP	NP	NP	L-ZP/ ZPSE	NP	NP	NP	L-ZP/ZPSE	\$11.4.18; \$11.4.20	
	Automobile / Motorcycle / Light Truck Sales, Rentals, Leasing; Pawn Lot or Vehicle Auctioneer* • Vehicle: .5/1,000 sf GFA • Bicycle: No requirement	NP	NP	NP	NP	NP	L-ZP	NP	NP	L-ZP	L-ZP	\$11.4.21	
	Heavy Vehicle/ Equipment Sales, Rentals & Service* • Vehicle: .5/1,000 sf GFA • Bicycle: No requirement	NP	NP	NP	NP	NP	P-ZPSE	NP	NP	NP	NP		
<b>INDUSTRIAL, MANUFACTURING &amp; WHOLESALE PRIMARY USE CLASSIFICATION</b>													
Communications and Information	Antennas Not Attached to a Tower* • No Parking Requirements	L-ZP	L-ZP	L-ZP	L-ZP	L-ZP	L-ZP	L-ZP	L-ZP	L-ZP	L-ZP	\$11.5.2	
	Communication Services • Vehicle: .5/1,000 sf GFA • Bicycle: No requirement	NP	NP	NP	NP	S-CC-3x: L-ZP/ ZPSE S-CC-5x: P-ZP	L-ZPSE	NP	L-ZP/ ZPSE	S-MX-3, -3A: L-ZP/ ZPSE All Others: P-ZP	S-MS-3: L-ZP/ZPSE S-MS-5: P-ZP	\$11.5.1	
	Telecommunications Towers* • No Parking Requirements	L-ZP/ ZPIN/ ZPSE	L-ZP/ ZPIN/ ZPSE	L-ZP/ ZPIN/ ZPSE	L-ZP/ ZPIN/ ZPSE	L-ZP/ ZPIN/ ZPSE	L-ZP/ ZPIN/ ZPSE	L-ZP/ ZPIN/ ZPSE	L-ZP/ ZPIN/ ZPSE	L-ZP/ ZPIN/ ZPSE	L-ZP/ZPIN/ ZPSE	L-ZP/ZPIN/ ZPSE	\$11.5.2
	Telecommunications Tower - Alternative Structure* • No Parking Requirements	L-ZP/ ZPIN	L-ZP/ ZPIN	L-ZP/ ZPIN	L-ZP/ ZPIN	L-ZP/ ZPIN	L-ZP/ ZPIN	L-ZP/ ZPIN	L-ZP/ ZPIN	L-ZP/ ZPIN	L-ZP/ZPIN	L-ZP/ZPIN	\$11.5.2
	Telecommunication Facilities - All Others* • No Parking Requirements	L-ZPIN	L-ZPIN	L-ZPIN	L-ZPIN	L-ZPIN	L-ZPIN	L-ZPIN	L-ZPIN	L-ZPIN	L-ZPIN	L-ZPIN	\$11.5.2
Industrial Services	Contractors, Special Trade - General • Vehicle: .5/1,000 sf GFA • Bicycle: No requirement	NP	NP	NP	NP	NP	L-ZP	NP	NP	L-ZP	L-ZP	\$11.5.3	
	Contractors, Special Trade - Heavy/ Contractor Yard*	NP	NP	NP	NP	NP	NP	NP	NP	NP	NP		

**Modernizing Parking Requirements**  
**LUTI Committee Review Draft**  
**May 13, 2025**

Article 3. Suburban Neighborhood Context  
 Division 3.4 Uses and Required Minimum Parking

KEY: \* = Need Not be Enclosed P = Permitted Use without Limitations L = Permitted Use with Limitations NP = Not Permitted Use ZP = Zoning Permit Review  
 ZPCIM = Subject to Zoning Permit Review with Community Information Meeting ZPIN = Subject to Zoning Permit Review with Informational Notice  
 ZPSE = Subject to Zoning Permit with Special Exception Review When no ZP, ZPCIM, ZPIN, ZPSE listed = No Zoning Permit required

USE CATEGORY	SPECIFIC USE TYPE • Vehicle Parking Reqmt: # spaces per unit of measurement • Bicycle Parking Reqmt Requirement: # spaces per unit of measurement (% Required Spaces in Enclosed Facility / % Required Spaces in Fixed Facility)											APPLICABLE USE LIMITATIONS
		S-SU-Fx S-SU-Ix	S-SU-A S-SU-D S-SU-F S-SU-FA S-SU-I	S-RH-2.5	S-MU-3 S-MU-5 S-MU-8 S-MU-12 S-MU-20	S-CC-3x S-CC-5x	S-CC-3 S-CC-5	S-MX-2x	S-MX-2 S-MX-2A	S-MX-3 S-MX-3A S-MX-5 S-MX-5A S-MX-8 S-MX-8A S-MX-12 S-MX-12A	S-MS-3 S-MS-5	
Industrial Services	Food Preparation and Sales, Commercial • Vehicle: .5 / 1,000 sf GFA • Bicycle: No requirement	NP	NP	NP	NP	L-ZP	L-ZP	L-ZPIN	L-ZPIN	L-ZP	L-ZP	\$ 11.5.5
	Laboratory, Research, Development and Technological Services • Vehicle: .5 / 1,000 sf GFA • Bicycle: No requirement	NP	NP	NP	NP	NP	L-ZP	NP	NP	L-ZP	L-ZP	\$11.5.6
	Service/Repair, Commercial • Vehicle: .5 / 1,000 sf GFA • Bicycle: No requirement	NP	NP	NP	NP	NP	L-ZP	NP	NP	L-ZP	L-ZP	\$11.5.7
Manufacturing and Production	Manufacturing, Fabrication & Assembly -- Custom • Vehicle: .5 / 1,000 sf GFA • Bicycle: No requirement	NP	NP	NP	NP	L-ZP	L-ZP	L-ZP	L-ZP	L-ZP	L-ZP	\$11.5.8
	Manufacturing, Fabrication & Assembly -- General • Vehicle: .5 / 1,000 sf GFA • Bicycle: No requirement	NP	NP	NP	NP	NP	L-ZP/ ZPSE	NP	NP	L-ZP/ ZPSE	L-ZP/ ZPSE	\$11.5.9
	Manufacturing, Fabrication & Assembly -- Heavy	NP	NP	NP	NP	NP	NP	NP	NP	NP	NP	
Mining & Extraction and Energy Producing Systems	Oil, Gas -- Production, Drilling*	NP	NP	NP	NP	NP	NP	NP	NP	NP	NP	
	Sand or Gravel Quarry*	NP	NP	NP	NP	NP	NP	NP	NP	NP	NP	
	Wind Energy Conversion Systems* • No Parking Requirements	L-ZPIN/ ZPSE	L-ZPIN/ ZPSE	L-ZPIN/ ZPSE	L-ZPIN/ ZPSE	L-ZPIN/ ZPSE	L-ZPIN/ ZPSE	L-ZPIN/ ZPSE	L-ZPIN/ ZPSE	L-ZPIN/ ZPSE	L-ZPIN/ ZPSE	\$11.5.13
Transportation Facilities	Airport*	NP	NP	NP	NP	NP	NP	NP	NP	NP	NP	
	Helipad, Helistop, Heliport* • No Parking Requirements	L-ZPIN	L-ZPIN	L-ZPIN	L-ZPIN	L-ZP	L-ZP	L-ZPIN	L-ZPIN	L-ZP	L-ZP	\$11.5.14
	Railroad Facilities*	NP	NP	NP	NP	NP	NP	NP	NP	NP	NP	
	Railway Right-of-Way* • No Parking Requirements	P-ZP	P-ZP	P-ZP	P-ZP	P-ZP	P-ZP	P-ZP	P-ZP	P-ZP	P-ZP	
	Terminal, Station or Service Facility for Passenger Transit System • Vehicle: .5 / 1,000 sf GFA • Bicycle: No requirement	L-ZP	L-ZP	L-ZP	L-ZP	P-ZP	P-ZP	P-ZP	P-ZP	P-ZP	P-ZP	\$11.5.16
Waste Related Services	Terminal, Freight, Air Courier Services	NP	NP	NP	NP	NP	NP	NP	NP	NP	NP	
	Automobile Parts Recycling Business*	NP	NP	NP	NP	NP	NP	NP	NP	NP	NP	
	Junkyard*	NP	NP	NP	NP	NP	NP	NP	NP	NP	NP	
	Recycling Center	NP	NP	NP	NP	NP	NP	NP	NP	NP	NP	
	Recycling Collection Station	NP	NP	NP	NP	NP	NP	NP	NP	NP	NP	
Wholesale, Storage, Warehouse & Distribution	Recycling Plant, Scrap Processor	NP	NP	NP	NP	NP	NP	NP	NP	NP	NP	
	Solid Waste Facility	NP	NP	NP	NP	NP	NP	NP	NP	NP	NP	
	Automobile Towing Service Storage Yard* Mini-storage Facility • Vehicle: 0.1 / 1,000 sf GFA • Bicycle: No requirement	NP	NP	NP	NP	P-ZP	P-ZP	NP	NP	L-ZP	L-ZP	\$11.5.23

KEY: \* = Need Not be Enclosed P = Permitted Use without Limitations L = Permitted Use with Limitations NP = Not Permitted Use ZP = Zoning Permit Review  
ZPCIM = Subject to Zoning Permit Review with Community Information Meeting ZPIN = Subject to Zoning Permit Review with Informational Notice  
ZPSE = Subject to Zoning Permit with Special Exception Review When no ZP, ZPCIM, ZPIN, ZPSE listed = No Zoning Permit required

USE CATEGORY	SPECIFIC USE TYPE • Vehicle Parking Reqmt: # spaces per unit of measurement • Bicycle Parking Reqmt Requirement: # spaces per unit of measurement (% Required Spaces in Enclosed Facility / % Required Spaces in Fixed Facility)	APPLICABLE USE LIMITATIONS										
		S-SU-Fx S-SU-Ix	S-SU-A S-SU-D S-SU-F S-SU-I	S-RH-2.5	S-MU-3 S-MU-5 S-MU-8 S-MU-12 S-MU-20	S-CC-3x S-CC-5x	S-CC-3 S-CC-5	S-MX-2 S-MX-2A	S-MX-3 S-MX-3A S-MX-5 S-MX-5A S-MX-8 S-MX-8A S-MX-12 S-MX-12A	S-MS-3 S-MS-5		
Wholesale, Storage, Warehouse, & Distribution	Vehicle Storage, Commercial* • Vehicle: .5 / 1,000 sf GFA • Bicycle: No requirement	NP	NP	NP	NP	NP	L-ZPIN	NP	NP	NP	NP	\$11.5.24
	Wholesale Trade or Storage, General • Vehicle: .5 / 1,000 sf GFA • Bicycle: No requirement	NP	NP	NP	NP	NP	P-ZPIN	NP	NP	NP	NP	
	Wholesale Trade or Storage, Light • Vehicle: .5 / 1,000 sf GFA • Bicycle: No requirement	NP	NP	NP	NP	L-ZP/ ZPIN/ ZPSE	L-ZP/ ZPIN/ ZPSE	NP	NP	L-ZP/ZPIN/ ZPSE	L-ZP/ZPIN/ ZPSE	\$11.5.26
<b>AGRICULTURE PRIMARY USE CLASSIFICATION</b>												
Agriculture	Aquaculture*	NP	NP	NP	NP	NP	NP	NP	NP	NP	NP	
	Garden, Urban* • Vehicle: .5 / 1,000 sf GFA • Bicycle: No requirement	L-ZP	L-ZP	L-ZP	L-ZP	L-ZP	L-ZP	L-ZP	L-ZP	L-ZP	L-ZP	\$11.6.2
	Husbandry, Animal*	NP	NP	NP	NP	NP	NP	NP	NP	NP	NP	
	Husbandry, Plant* Plant Nursery • Vehicle: .5 / 1,000 sf GFA • Bicycle: No requirement	NP	NP	NP	NP	L-ZP	L-ZP	L-ZP	L-ZP	L-ZP	L-ZP	\$11.6.4
<b>ACCESSORY TO PRIMARY RESIDENTIAL USES USE CLASSIFICATION</b>												
Accessory to Primary Residential Uses  (Parking is Not Required for Accessory Uses Unless Specifically Stated in this Table or in an Applicable Use Limitation)	Unlisted Accessory Uses	L - Applicable to all Zone Districts										\$11.7
	Accessory Dwelling Unit	L-ZP	L-ZP	L-ZP	L-ZP	L-ZP	L-ZP	L-ZP	L-ZP	L-ZP	L-ZP	\$11.7; \$11.8.2
	Domestic Employees	L	L	L	L	L	L	L	L	L	L	\$11.7; \$11.8.3
	Garden*	L	L	L	L	L	L	L	L	L	L	\$11.7; \$11.8.4
	Keeping of Household Animals*	L / L-ZPIN	L / L-ZPIN	L / L-ZPIN	L / L-ZPIN	L / L-ZPIN	L / L-ZPIN	L / L-ZPIN	L / L-ZPIN	L / L-ZPIN	L / L-ZPIN	\$11.7; \$11.8.5
	Keeping and Off-Street Parking of Vehicles, Motorcycles, Trailers & Recreational Vehicles*	L	L	L	L	L	L	L	L	L	L	\$11.7; \$10.9
	Kennel or Exercise Run*	L	L	L	L	L	L	L	L	L	L	\$11.7; \$11.8.6
	Limited Commercial Sales, Services Accessory to Multi-Unit Dwelling Use	NP	NP	NP	L-ZP	Not Applicable - See Permitted Primary Uses						\$11.7; \$11.8.7
	Outdoor Storage, Residential*	L	L	L	L	L	L	L	L	L	L	\$11.7; \$11.8.8
	Second Kitchen Accessory to Single Unit Dwelling Use	L-ZP	L-ZP	L-ZP	L-ZP	L-ZP	L-ZP	L-ZP	L-ZP	L-ZP	L-ZP	\$11.7; \$11.8.9
	Short-term Rental	L	L	L	L	L	L	L	L	L	L	\$11.7; \$11.8.10
	Vehicle Storage, Repair, and Maintenance*	L	L	L	L	L	L	L	L	L	L	\$11.7; \$10.9
Wind Energy Conversion Systems*	L-ZPIN/ ZPSE	L-ZPIN/ ZPSE	L-ZPIN/ ZPSE	L-ZPIN/ ZPSE	Not Applicable - See Permitted Primary Uses						\$11.8; \$11.5.13	
Yard or Garage Sales*	L	L	L	L	L	L	L	L	L	L	\$11.8; \$11.8.11	





KEY: \* = Need Not be Enclosed P = Permitted Use without Limitations L = Permitted Use with Limitations NP = Not Permitted Use ZP = Zoning Permit Review  
ZPCIM = Subject to Zoning Permit Review with Community Information Meeting ZPIN = Subject to Zoning Permit Review with Informational Notice  
ZPSE = Subject to Zoning Permit with Special Exception Review When no ZP, ZPCIM, ZPIN, ZPSE listed = No Zoning Permit required

USE CATEGORY	SPECIFIC USE TYPE • <del>Vehicle Parking Reqmt: # spaces per unit of measurement</del> • <del>Bicycle Parking Reqmt Requirement: # spaces per unit of measurement (% Required Spaces in Enclosed Facility / % Required Spaces in Fixed Facility)</del>											APPLICABLE USE LIMITATIONS																
		S-SU-A	S-SU-D	S-SU-F	S-SU-Fx	S-SU-FA	S-SU-Ix	S-SU-I	S-RH-2.5	S-MU-3	S-MU-5		S-MU-8	S-MU-12	S-MU-20	S-CC-3x	S-CC-5x	S-CC-3	S-CC-5	S-MX-2x	S-MX-2	S-MX-3	S-MX-3A	S-MX-5	S-MX-5A	S-MX-8	S-MX-8A	S-MX-12

**ACCESSORY TO PRIMARY NONRESIDENTIAL USES USE CLASSIFICATION**

USE CATEGORY	SPECIFIC USE TYPE	L - Applicable to all Zone Districts										APPLICABLE USE LIMITATIONS																				
		S-SU-A	S-SU-D	S-SU-F	S-SU-Fx	S-SU-FA	S-SU-Ix	S-SU-I	S-RH-2.5	S-MU-3	S-MU-5		S-MU-8	S-MU-12	S-MU-20	S-CC-3x	S-CC-5x	S-CC-3	S-CC-5	S-MX-2x	S-MX-2	S-MX-3	S-MX-3A	S-MX-5	S-MX-5A	S-MX-8	S-MX-8A	S-MX-12	S-MX-12A	S-MS-3	S-MS-5	
Accessory to Primary Nonresidential Uses  (Parking is Not Required for Accessory Uses Unless Specifically Stated in this Table or in an Applicable Use Limitation)	Unlisted Accessory Uses	L - Applicable to all Zone Districts										\$11.7; §11.10.1																				
	Amusement Devices Accessory to Eating/Drinking Establishments, College/University, and Theater Uses	NP	NP	NP	NP	NP	NP	L-ZP	L-ZP	L-ZP	L-ZP	L-ZP	L-ZP	L-ZP	L-ZP	L-ZP	L-ZP	L-ZP	L-ZP	L-ZP	L-ZP	L-ZP	L-ZP	L-ZP	L-ZP	L-ZP	L-ZP	L-ZP	L-ZP	L-ZP	\$11.7; §11.10.2	
	Automobile Rental Services Accessory to Certain Retail Uses*	NP	NP	NP	NP	NP	NP	L	Not Applicable - See Permitted Primary Uses	NP	NP	NP	NP	NP	NP	NP	NP	NP	NP	NP	NP	NP	NP	NP	NP	NP	NP	NP	NP	NP	NP	\$11.7; §11.10.3
	Book or gift store; media recording and production facilities accessory to public libraries, museums, places of religious assembly, colleges, or universities	L	L	L	L	L	L	L	Not Applicable - See Permitted Primary Uses							\$11.7; §11.10.4																
	Car Wash Bay Accessory to Automobile Services	NP	NP	NP	NP	NP	NP	L-ZP	L-ZP	NP	NP	L-ZP	NP	NP	L-ZP	NP	L-ZP	NP	L-ZP	NP	L-ZP	NP	L-ZP	NP	L-ZP	NP	L-ZP	NP	L-ZP	L-ZP	\$11.7; §11.10.5	
	College accessory to a Place for Religious Assembly	L	L	L	L	L	L	L	Not Applicable - See Permitted Primary Uses			L	Not Applicable - See Permitted Primary Uses				\$11.7; §11.10.6															
	Conference Facilities Accessory to Hotel Use	NP	NP	NP	NP	NP	NP	L	L	NP	NP	L	L	L	L	L	L	L	L	L	L	L	L	L	L	L	L	L	L	L	\$11.7; §11.10.7	
	Drive Through Facility Accessory to Eating/Drinking Establishments and to Retail Sales, Service, and Repair Uses*	NP	NP	NP	NP	NP	NP	L-ZP	L-ZP	NP	L-ZP	L-ZP	NP	L-ZP	L-ZP	NP	L-ZP	L-ZP	NP	L-ZP	L-ZP	NP	L-ZP	L-ZP	NP	L-ZP	L-ZP	NP	L-ZP	L-ZP	\$11.7; §11.10.8	
	Emergency Vehicle Access Point Garden*	L	L	L	L	L	L	L	L	L	L	L	L	L	L	L	L	L	L	L	L	L	L	L	L	L	L	L	L	L	\$11.7; §11.10.10	
	Keeping of Animals	L/L-ZPIN	L/L-ZPIN	L/L-ZPIN	L/L-ZPIN	L/L-ZPIN	L/L-ZPIN	L/L-ZPIN	L/L-ZPIN	L/L-ZPIN	L/L-ZPIN	L/L-ZPIN	L/L-ZPIN	L/L-ZPIN	L/L-ZPIN	L/L-ZPIN	L/L-ZPIN	L/L-ZPIN	L/L-ZPIN	L/L-ZPIN	L/L-ZPIN	L/L-ZPIN	L/L-ZPIN	L/L-ZPIN	L/L-ZPIN	L/L-ZPIN	L/L-ZPIN	L/L-ZPIN	L/L-ZPIN	L/L-ZPIN	L/L-ZPIN	\$11.7; § 11.10.11
	Limited Commercial Sales, Services	L	L	L	L	L	L	L	L	L	L	L	L	L	L	L	L	L	L	L	L	L	L	L	L	L	L	L	L	L	\$11.7; §11.10.12	
	Nonresidential Uses in Existing Business Structures In Residential Zones - Accessory Uses	L	L	L	L	L	L	L	Not Applicable							\$11.7; §11.4.6																
	Occasional Sales, Services Accessory to Primary Places of Religious Assembly or Primary Uses Operated by Nonprofit Organizations*	L	L	L	L	L	L	L	L	L	L	L	L	L	L	L	L	L	L	L	L	L	L	L	L	L	L	L	L	L	\$11.7; §11.10.13	
	Outdoor Gathering Area*	L/L-ZP/L-ZPIN	L/L-ZP/L-ZPIN	L/L-ZP/L-ZPIN	L/L-ZP/L-ZPIN	L/L-ZP/L-ZPIN	L/L-ZP/L-ZPIN	L/L-ZP/L-ZPIN	L/L-ZP/L-ZPIN	L/L-ZP/L-ZPIN	L/L-ZP/L-ZPIN	L/L-ZP/L-ZPIN	L/L-ZP/L-ZPIN	L/L-ZP/L-ZPIN	L/L-ZP/L-ZPIN	L/L-ZP/L-ZPIN	L/L-ZP/L-ZPIN	L/L-ZP/L-ZPIN	L/L-ZP/L-ZPIN	L/L-ZP/L-ZPIN	L/L-ZP/L-ZPIN	L/L-ZP/L-ZPIN	L/L-ZP/L-ZPIN	L/L-ZP/L-ZPIN	L/L-ZP/L-ZPIN	L/L-ZP/L-ZPIN	L/L-ZP/L-ZPIN	L/L-ZP/L-ZPIN	L/L-ZP/L-ZPIN	L/L-ZP/L-ZPIN	\$11.7; §11.10.14	
	Outdoor Entertainment Accessory to an Eating/Drinking Establishment Use*	NP	NP	NP	NP	NP	NP	L-ZPIN/ZPSE	L-ZPIN/ZPSE	NP	NP	L-ZPIN/ZPSE	L-ZPIN/ZPSE	NP	NP	L-ZPIN/ZPSE	L-ZPIN/ZPSE	NP	NP	L-ZPIN/ZPSE	L-ZPIN/ZPSE	NP	NP	L-ZPIN/ZPSE	L-ZPIN/ZPSE	NP	NP	L-ZPIN/ZPSE	L-ZPIN/ZPSE	\$11.7; §11.10.15		
	Outdoor Retail Sale and Display*	NP	NP	NP	NP	NP	NP	L-ZP/ZPSE	L-ZP/ZPSE	NP	NP	L-ZP/ZPSE	L-ZP/ZPSE	NP	NP	L-ZP/ZPSE	L-ZP/ZPSE	NP	NP	L-ZP/ZPSE	L-ZP/ZPSE	NP	NP	L-ZP/ZPSE	L-ZP/ZPSE	NP	NP	L-ZP/ZPSE	L-ZP/ZPSE	\$11.7; §11.10.16		
Outdoor Storage, General*	NP	NP	NP	NP	NP	NP	L-ZP	L-ZP	NP	NP	L-ZP	L-ZP	NP	NP	L-ZP	L-ZP	NP	NP	L-ZP	L-ZP	NP	NP	L-ZP	L-ZP	NP	NP	L-ZP	L-ZP	\$11.7; §11.10.17			
Outdoor Storage, Limited*	NP	NP	NP	NP	NP	NP	L	L	L	L	L	L	L	L	L	L	L	L	L	L	L	L	L	L	L	L	L	L	\$11.7; §11.10.18			
Rental or Sales of Adult Material Accessory to a Permitted Bookstore Retail Sales Use	NP	NP	NP	NP	NP	NP	L	L	L	L	L	L	L	L	L	L	L	L	L	L	L	L	L	L	L	L	L	L	\$11.7; §11.10.19			
Retail Food Establishment, Mobile (Food Truck)*	L-ZP	L-ZP	L-ZP	L-ZP	L-ZP	L-ZP	L-ZP	L-ZP	L-ZP	L-ZP	L-ZP	L-ZP	L-ZP	L-ZP	L-ZP	L-ZP	L-ZP	L-ZP	L-ZP	L-ZP	L-ZP	L-ZP	L-ZP	L-ZP	L-ZP	L-ZP	L-ZP	L-ZP	\$11.7; §11.10.20			

**Modernizing Parking Requirements**  
**LUTI Committee Review Draft**  
**May 13, 2025**

Article 3. Suburban Neighborhood Context  
 Division 3.4 Uses ~~and Required Minimum Parking~~

KEY: \* = Need Not be Enclosed P = Permitted Use without Limitations L = Permitted Use with Limitations NP = Not Permitted Use ZP = Zoning Permit Review  
 ZPCIM = Subject to Zoning Permit Review with Community Information Meeting ZPIN = Subject to Zoning Permit Review with Informational Notice  
 ZPSE = Subject to Zoning Permit with Special Exception Review When no ZP, ZPCIM, ZPIN, ZPSE listed = No Zoning Permit required

USE CATEGORY	SPECIFIC USE TYPE • <del>Vehicle Parking Reqmt: # spaces per unit of measurement</del> • <del>Bicycle Parking Reqmt Requirement: # spaces per unit of measurement (% Required Spaces in Enclosed Facility / % Required Spaces in Fixed Facility)</del>											APPLICABLE USE LIMITATIONS
		S-SU-A S-SU-D S-SU-F S-SU-Fx S-SU-Ix	S-SU-FA S-SU-I	S-RH-2.5	S-MU-3 S-MU-5 S-MU-8 S-MU-12 S-MU-20	S-CC-3x S-CC-5x	S-CC-3 S-CC-5	S-MX-2x	S-MX-2 S-MX-2A	S-MX-3 S-MX-3A S-MX-5 S-MX-5A S-MX-8 S-MX-8A S-MX-12 S-MX-12A	S-MS-3 S-MS-5	

**TEMPORARY USE CLASSIFICATION**

	L - Applicable to all Zone Districts											\$11.11.1	
	Not Applicable - See Permitted Primary Uses												
Temporary Uses (Parking is Not Required for Temporary Uses Unless Specifically Stated in this Table or in an Applicable Use Limitations)	Unlisted Temporary Uses												\$11.11.1
	Ambulance Service - Temporary	NP	NP	NP	L-ZP								\$11.11.2
	Amusement / Entertainment - Temporary*	NP	NP	NP	NP	NP	NP	NP	NP	NP	NP	\$11.11.3	
	Bazaar, Carnival, Circus or Special Event*	L/L-ZP	L/L-ZP	L/L-ZP	L/L-ZP	L/L-ZP	L/L-ZP	L/L-ZP	L/L-ZP	L/L-ZP	L/L-ZP	\$11.11.4	
	Building or yard for construction materials*	L-ZP	L-ZP	L-ZP	L-ZP	L-ZP	L-ZP	L-ZP	L-ZP	L-ZP	L-ZP	\$11.11.5	
	Concrete, Asphalt, and Rock Crushing Facility*	L-ZP	L-ZP	L-ZP	L-ZP	L-ZP	L-ZP	L-ZP	L-ZP	L-ZP	L-ZP	\$11.11.6	
	Fence for Demolition or Construction Work	L-ZP	L-ZP	L-ZP	L-ZP	L-ZP	L-ZP	L-ZP	L-ZP	L-ZP	L-ZP	\$11.11.7	
	Health Care Center	L-ZP	L-ZP	L-ZP	L-ZP	P-ZP	P-ZP	P-ZP	P-ZP	P-ZP	P-ZP	\$11.11.8	
	Noncommercial Concrete Batching Plant*	L-ZP	L-ZP	L-ZP	L-ZP	L-ZP	L-ZP	L-ZP	L-ZP	L-ZP	L-ZP	\$11.11.9	
	Outdoor Retail Sales - Pedestrian / Transit Mall*	NP	NP	NP	NP	NP	NP	NP	NP	NP	NP		
	Outdoor Retail Sales*	NP	NP	NP	NP	L-ZP	L-ZP	L-ZP	L-ZP	L-ZP	NP	\$11.11.11	
	Outdoor Sales, Seasonal*	NP	NP	NP	NP	L-ZP	L-ZP	L-ZP/ZPIN	L-ZP/ZPIN	L-ZP	L-ZP	\$11.11.12	
	Parking Lot Designated for a Special Event*	L-ZP	L-ZP	L-ZP	L-ZP	L-ZP	L-ZP	L-ZP	L-ZP	L-ZP	L-ZP	\$11.11.13	
	Retail Food Establishment, Mobile (Food Truck)*	NP	NP	NP	NP	L/L-ZP	L/L-ZP	L/L-ZP	L/L-ZP	L/L-ZP	L/L-ZP	\$11.11.14	
	Temporary Construction Office	L-ZP	L-ZP	L-ZP	L-ZP	L-ZP	L-ZP	L-ZP	L-ZP	L-ZP	L-ZP	\$11.11.15	
	Temporary Office - Real Estate Sales	L-ZP	L-ZP	L-ZP	L-ZP	L-ZP	L-ZP	L-ZP	L-ZP	L-ZP	L-ZP	\$11.11.16	
	Temporary Managed Community*	L-ZPCIM	L-ZPCIM	L-ZPCIM	L-ZPCIM	L-ZPCIM	L-ZPCIM	L-ZPCIM	L-ZPCIM	L-ZPCIM	L-ZPCIM	\$11.11.17	
Tent for Religious Services	NP	NP	NP	NP	NP	NP	NP	NP	NP	NP			

## SECTION 4.3.3 BUILDING FORM STANDARDS FOR PRIMARY STRUCTURES

### 4.3.3.1 Applicability

All development, except detached accessory structures, in all the Urban Edge Neighborhood Context zone districts

### 4.3.3.2 District Specific Standards Summary

The table below states the building forms allowed in each zone district. The table also summarizes the maximum number of structures allowed per Zone Lot, which is stated in more detail in Section 1.2.3.5, Number of Uses and Structures Allowed per Zone Lot.

See also Division 1.4, Building Form Standards - General Provisions, for additional standards related to initial assignment of building form standards to new and existing structures and for rules governing combining or changing building forms. Building Connectors between two detached structures shall follow the standards provided in Section 1.4.5, Applicable Building Form Standards for Detached Structures with Building Connector.

Urban Edge (E-) Neighborhood Context Zone Districts		Building Forms											
		Suburban House	Urban House	Duplex	Tandem House	Row House	Garden Court	Town House	Apartment	Drive Thru Services	Drive Thru Restaurant	General	Shopfront
<b>Max Number of Primary Structures Per Zone Lot</b>		1*	1*	1*	2	No Maximum							
<b>RESIDENTIAL ZONE DISTRICTS</b>													
Single Unit (SU)	E-SU-A, -B, -D		■		●								
	E-SU-Dx, -G	■	■		●								
Two Unit (TU)	E-TU-B, -C		■	■	■								
Row House (RH)	E-RH-2.5	■	■	■	■	■							
Multi Unit (MU)	E-MU-2.5	■	■	■	■		■	■	■				
<b>COMMERCIAL MIXED USE ZONE DISTRICTS</b>													
Residential Mixed Use (RX)	E-RX-3, -5							■				■	
Commercial Corridor (CC)	E-CC-3, -3x								□	□	■		
Mixed Use (MX)	E-MX-2x							■			■	■	
	E-MX-2, -2A, 3, 3A							■	□	□	■	■	
Main Street (MS)	E-MS-2x							■				■	
	E-MS-2, -3, -5							■	□	□		■	

■ = Allowed □ = Allowed subject to geographic limitations

● = Tandem House building form allowed subject to exception stated in Section 1.2.3.5.B, Allowed Increases on Zone Lot with Certain Existing Accessory Structures in SU- and TU- Zone Districts

\*See Section 1.2.3.5, Number of Uses and Structures Allowed Per Zone Lot for exceptions

### 4.3.3.3 District Specific Standards

#### A. Suburban House

Not to Scale. Illustrative Only.

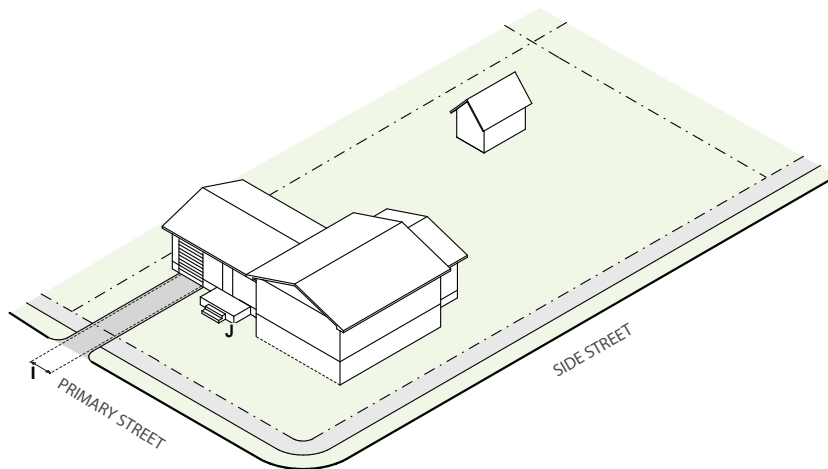
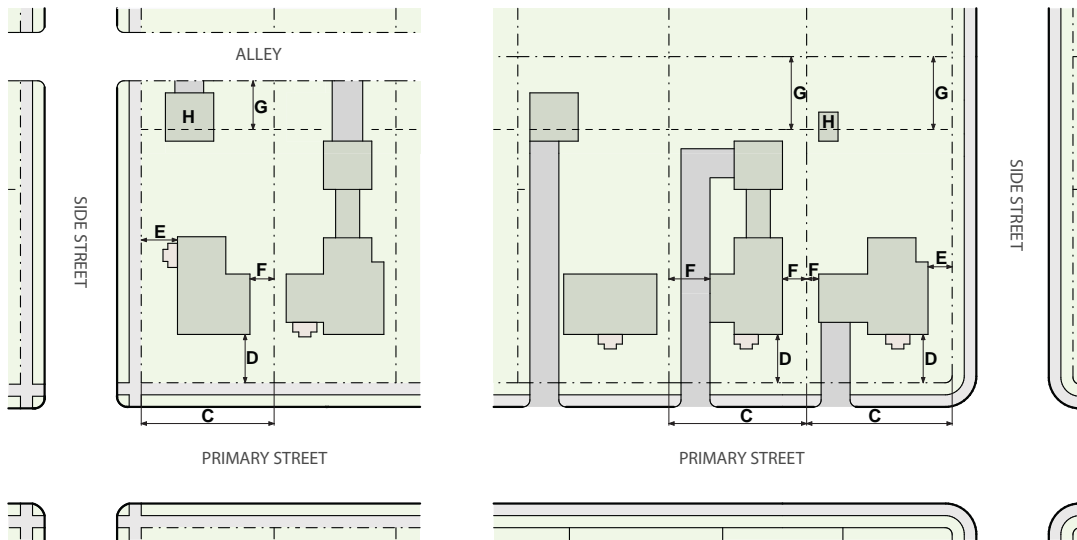
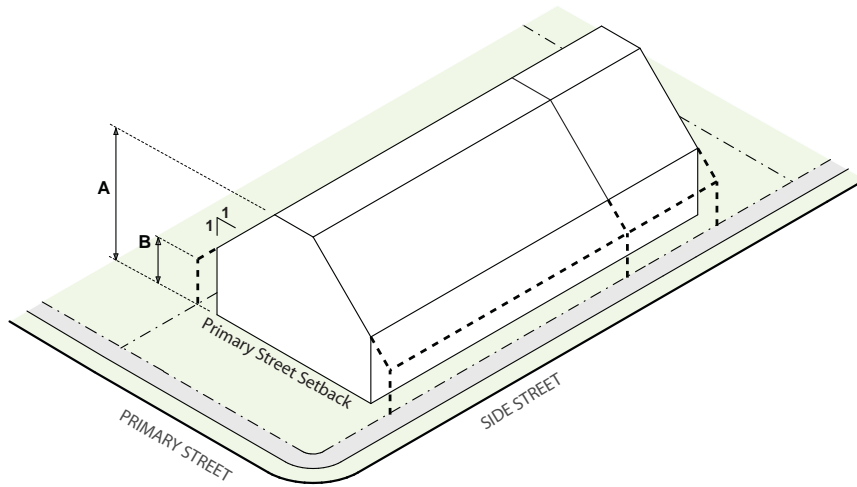

## SUBURBAN HOUSE

<b>HEIGHT</b>		E-SU-Dx	E-SU-G	E-RH-2.5 E-MU-2.5
A	Stories, front 65% / Rear 35% of zone lot depth (max)	2.5/2.5	2.5/2.5	2.5/2.5
A	Feet, front 65% / rear 35% of zone lot depth (max)	30'/30'	30'/30'	30'/30'
	Feet, permitted height increase	1' for every 5' increase in Zone Lot width over 50' up to a maximum height of 35'		
B	Bulk Plane Vertical Height at Side Interior and Side Street Zone Lot Line in front 65% / rear 35% of zone lot depth	10'/10'	10'/10'	10'/10'
	Bulk Plane Slope from Side Interior and Side Street Zone Lot Line	45°	45°	45°
<b>SITING</b>		E-SU-Dx	E-SU-G	E-RH-2.5 E-MU-2.5
<b>ZONE LOT</b>				
	Zone Lot Area (min)	6,000 sf	9,000 sf	6,000 sf
C	Zone Lot Width (min)	50'	62.5'	50'
<b>SETBACKS AND BUILDING COVERAGE BY ZONE LOT WIDTH</b>		All E-SU, RH, MU		
		61' or Less	Greater than 61'	
D	Primary Street (min)	For -MU Districts: Calculated per Sec. 13.1.5.9, Determination of Primary Street Setback Offset Distance, or 20', whichever is less For all other Districts: Calculated per Sec. 13.1.5.9		
E	Side Street (min)	5'	5'	
F	Side Interior (min)	5'	7.5'	
G	Rear, where Alley (public or private) abuts a Rear Zone Lot Line (min)	12'	12'	
G	Rear, where Alley (public or private) does not abut a Rear Zone Lot Line (min)	20'	20'	
	Building Coverage per Zone Lot, including all accessory structures (max)	45%	45%	
<b>PARKING BY ZONE LOT WIDTH</b>		61' or Less	62' or Greater	
	Parking and Drive Lot Coverage in Primary Street Setback (max)	33%	33%	
	Vehicle Access	From Alley; or Street access allowed when no Alley present (See Sec. 4.3.7.5, Vehicle Access From Alley Required - Exceptions)		
H	<b>DETACHED ACCESSORY STRUCTURES</b>	See Sec. 4.3.4, Bldg. Form Std.s for Detached Accessory Structures		
<b>DESIGN ELEMENTS</b>		All E-SU, RH, MU		
<b>BUILDING CONFIGURATION</b>				
	Rooftop or Second Story Decks	See Section 4.3.5.2, Rooftop or Second Story Decks (1) Shall not be located closer to the minimum Primary Street setback line than the Primary Street-facing Façade(s) comprising at least 65% of the total width of the primary structure enclosing the primary use. (2) May follow the General Detached Structure Building Form for Side Street, Side Interior and Rear setbacks provided no permitted height increase has been applied to the Attached Garage		
	Attached Garage Allowed			
I	Primary Street-Facing Attached Garage Door Width in front 50% of zone lot depth(max)	35% of the entire width of the Primary Street-facing Façade of the primary structure or 16', whichever is greater		
	Upper Story Stepback, for any portion of building with Low-Slope Roof, above 25': Primary Street (min)	10'		
<b>STREET LEVEL ACTIVATION</b>				
J	Pedestrian Access, Primary Street	Entry Feature		
<b>USES</b>		All E-SU, RH, MU		
		Primary Uses shall be limited to Single Unit Dwelling and permitted Congregate Living, Residential Care and Nonresidential uses. See Division 4.4, Uses, and Required Minimum Parking		

See Sections 4.3.5 - 4.3.7 for Supplemental Design Standards, Design Standard Alternatives, and Design Standard Exceptions.

## URBAN HOUSE

<b>HEIGHT</b>		All E-SU, TU, RH, MU						
	Stories, front 65% / rear 35% of zone lot depth (max)	2.5/1						
A/B	Feet, front 65% / rear 35% of zone lot depth (max)	30'/17'						
	Feet, front 65% of zone lot depth, permitted height increase	1' for every 5' increase in Zone Lot width over 50' up to a maximum height of 35'						
	Feet, rear 35% of zone lot depth, permitted height increase	1' for every 3' increase in side setback up to a maximum height of 19'						
C/D	Bulk Plane Vertical Height at Side Interior and Side Street Zone Lot in front 65% / rear 35% of zone lot depth	17'/10'						
	Bulk Plane Slope from Side Interior and Side Street Zone Lot	45°						
<b>SITING</b>		E-SU-A	E-SU-B	E-SU-D, -Dx	E-SU-G	E-TU-B	E-TU-C	E-RH-2.5 E-MU-2.5
<b>ZONE LOT</b>								
	Zone Lot Area (min)	3,000 sf	4,500 sf	6,000 sf	9,000 sf	4,500 sf	5,500 sf	4,500 sf
E	Zone Lot Width (min)	25'	35'	50'	62.5'	35'	50'	35'
<b>SETBACKS AND BUILDING COVERAGE BY ZONE LOT WIDTH</b>		All E-SU, TU, RH, MU						
		30' or less	Greater than 30' and up to 40'	Greater than 40' and less than 75'	75' or Greater			
F	Primary Street (min)	For -MU Districts: Calculated per Sec. 13.1.5.9, Determination of Primary Street Setback Offset Distance, or 20', whichever is less For all other Districts: Calculated per Sec. 13.1.5.9						
G	Side Street (min)	3'	5'	5'	7.5'			
H	Side Interior (min)	3'	3' min one side/ 10' min combined	5'	10'			
I	Rear, where Alley (public or private) abuts a Rear Zone Lot Line (min)	12'	12'	12'	12'			
I	Rear, where Alley (public or private) does not abut a Rear Zone Lot Line (min)	20'	20'	20'	20'			
	Building Coverage per Zone Lot, including all accessory structures (max)	60%	45%	45%	40%			
<b>PARKING BY ZONE LOT WIDTH</b>								
	Parking and Drive Lot Coverage in Primary Street Setback (max)	Maximum 16-foot wide measured parallel to the Primary Street zone lot line for any length, or 33% of the zone lot area within the Primary Street setback, whichever is greater						
	Vehicle Access	From Alley; or Street access allowed when no Alley present (See Sec. 4.3.7.5, Vehicle Access From Alley Required - Exceptions)						
J	<b>DETACHED ACCESSORY STRUCTURES</b>	See Sec. 4.3.4, Building Form Standards for Detached Accessory Structures						
<b>DESIGN ELEMENTS</b>		All E-SU, TU, RH, MU						
<b>BUILDING CONFIGURATION</b>								
	Rooftop or Second Story Decks	See Section 4.3.5.2, Rooftop or Second Story Decks						
	Attached Garage Allowed	(1) Shall not be located closer to the minimum Primary Street setback line than the Primary Street-facing Façade(s) comprising at least 65% of the total width of the primary structure enclosing the primary use. (2) May follow the General Detached Structure building form for Side Street, Side Interior and Rear setbacks provided no permitted height increase has been applied to the Attached Garage						
	Primary Street-Facing Attached Garage Door Width in front 50% of zone lot depth(max)	35% of the entire width of the Primary Street-facing Façade of the primary structure or 16', whichever is greater						
	Upper Story Stepback, for any portion of building with Low-Slope Roof, above 25': Primary Street (min)	10'						
<b>STREET LEVEL ACTIVATION</b>								
K	Pedestrian Access, Primary Street	Entry Feature						
<b>USES</b>		All E-SU, TU, RH, MU						
		Primary Uses shall be limited to Single Unit Dwelling and permitted Congregate Living, Residential Care and Nonresidential uses. See Division 4.4, Uses, and Required Minimum Parking						
See Sections 4.3.5 - 4.3.7 for Supplemental Design Standards, Design Standard Alternatives, and Design Standard Exceptions.								

## DUPLEX

<b>HEIGHT</b>		<b>E-TU-B</b>	<b>E-TU-C</b>	<b>E-RH-2.5; E-MU-2.5</b>
	Stories, front 65% / rear 35% of zone lot depth (max)	2.5/1	2.5/1	2.5/1
<b>A/B</b>	Feet, front 65% / rear 35% of zone lot depth (max)	30'/17'	30'/17'	30'/17'
	Feet, front 65% of zone lot depth, permitted height increase	1' for every 5' increase in Zone Lot width over 50' up to a maximum height of 35'		
	Feet, rear 35% of zone lot depth, permitted height increase	1' for every 3' increase in side setback up to a maximum height of 19'		
<b>C/D</b>	Bulk Plane Vertical Height at Side Interior and Side Street Zone Lot Lines in front 65% / rear 35% of zone lot	17'/10'	17'/10'	17'/10'
	Bulk Plane Slope from Side Interior and Side Street Zone Lot Lines	45°	45°	45°

<b>SITING</b>		<b>E-TU-B</b>	<b>E-TU-C</b>	<b>E-RH-2.5; E-MU-2.5</b>
<b>ZONE LOT</b>				
	Zone Lot Area (min)	4,500 sf	5,500 sf	4,500 sf
<b>E</b>	Zone Lot Width (min)	35'	50'	35'

<b>SETBACKS AND BUILDING COVERAGE BY ZONE LOT WIDTH</b>		<b>All E-TU, RH, MU Districts</b>			
		<b>30' or less</b>	<b>Greater than 30' and up to 40'</b>	<b>Greater than 40' and less than 75'</b>	<b>75' or Greater</b>
<b>F</b>	Primary Street (min)	For -MU Districts: Calculated per Sec. 13.1.5.9, Determination of Primary Street Setback Offset Distance, or 20', whichever is less For all other Districts: Calculated per Sec. 13.1.5.9			
<b>G</b>	Side Street (min)	3'	5'	5'	7.5'
<b>H</b>	Side Interior (min)	3'	3' min one side/ 10' min combined	5'	10'
<b>I</b>	Rear, where Alley (public or private) abuts a Rear Zone Lot Line (min)	12'	12'	12'	12'
<b>I</b>	Rear, where Alley (public or private) does not abut a Rear Zone Lot Line (min)	20'	20'	20'	20'
	Building Coverage per Zone Lot, including all accessory structures (max)	60%	45%	45%	40%
<b>PARKING BY ZONE LOT WIDTH</b>					
	Parking and Drive Lot Coverage in Primary Street Setback (max)	50%	50%	50%	50%
	Vehicle Access	From Alley; or Street access allowed when no Alley present (See Sec. 4.3.7.5, Vehicle Access From Alley Required - Exceptions)			
<b>J</b>	<b>DETACHED ACCESSORY STRUCTURES</b>	See Sec. 4.3.4, Building Form Standards for Detached Accessory Structures			

<b>DESIGN ELEMENTS</b>		<b>E-TU-B</b>	<b>E-TU-C</b>	<b>E-RH-2.5; E-MU-2.5</b>
<b>BUILDING CONFIGURATION</b>				
	Rooftop or Second Story Decks	See Section 4.3.5.2, Rooftop or Second Story Decks		
	Attached Garage Allowed	(1) Shall not be located closer to the minimum Primary Street setback line than the Primary Street-facing Façade(s) comprising at least 65% of the total width of the primary structure enclosing the primary use. (2) May follow the General Detached Structure building form standards for Side Street, Side Interior and Rear setbacks provided no permitted height increase has been applied to the Attached Garage		
	Primary Street Facing Attached Garage Door Width in front 50% of zone lot depth(max)	35% of the entire width of the front Primary Street-facing Façade of the dwelling primary structure or 16', whichever is greater		
	Upper Story Stepback, for any portion of building with Low-Slope Roof, above 25': Primary Street (min)	10'	10'	10'
<b>STREET LEVEL ACTIVATION</b>				
<b>K</b>	Pedestrian Access, Primary Street	Entry Feature		

<b>USES</b>		<b>All E-TU, RH, MU Districts</b>			
Primary Uses shall be limited to Two Unit Dwelling and permitted Congregate Living, Residential Care and Nonresidential uses. See Division 4.4, Uses <b>and Required Minimum Parking</b> .					

See Sections 4.3.5 - 4.3.7 for Supplemental Design Standards, Design Standard Alternatives, and Design Standard Exceptions.

## TANDEM HOUSE

<b>HEIGHT</b>		E-TU-B	E-TU-C	E-RH-2.5; E-MU-2.5	
	Stories (max)	2.5	2.5	2.5	
A/B	Feet, front 65% /rear 35% of zone lot depth (max)	30'/24'	30'/24'	30'/24'	
	Feet, front 65% of zone lot depth, permitted height increase	1' for every 5' increase in Zone Lot width over 50' up to a maximum height of 35'			
C/D	Bulk Plane Vertical Height at Side Interior and Side Street zone lot line in front 65% / rear 35% of zone lot depth	17'/10'	17'/10'	17'/10'	
	Bulk Plane Slope from Side Interior and Side Street zone lot line	45°	45°	45°	
<b>SITING</b>		E-TU-B	E-TU-C	E-RH-2.5; E-MU-2.5	
<b>ZONE LOT</b>					
	Zone Lot Area (min)	4,500 sf	5,500 sf	4,500 sf	
E	Zone Lot Width (min)	35'	50'	35'	
<b>SETBACKS AND BUILDING COVERAGE BY ZONE LOT WIDTH</b>					
		30' or less	Greater than 30' and up to 40'	Greater than 40' and less than 75'	75' or Greater
F	Primary Street (min)	For -MU Districts: Calculated per Sec. 13.1.5.9, Determination of Primary Street Setback Offset Distance, or 20', whichever is less For all other Districts: Calculated per Sec. 13.1.5.9			
G	Side Street (min)	3'	5'	5'	7.5'
H	Side Interior, for Primary Structure #1 (min one side/min combined)	3'/6'	3'/10'	5'/10'	10'/20'
I	Side Interior, for Primary Structure #2 (min one side/min combined)*	3'/6'	3'/10'	5'/10'	10'/20'
J	Rear, for Primary Structure #1, as a % of zone lot depth (min)	50%	50%	50%	50%
K	Rear, for Primary Structure #2 (min)	5'	5'	5'	5'
	Building Coverage per Zone Lot, including all accessory structures (max)	60%	45%	45%	40%
<b>BUILDING SEPARATION</b>					
L	Horizontal distance between closest above-grade portions of each Primary Structure (min)	6'	6'	6'	6'
<b>PARKING BY ZONE LOT WIDTH</b>					
	Parking and Drive Lot Coverage in Primary Street Setback (max)	50%	50%	50%	50%
	Vehicle Access	From Alley; or Street access allowed when no Alley present (See Sec. 4.3.7.5, Vehicle Access From Alley Required - Exceptions)			
	<b>DETACHED ACCESSORY STRUCTURES</b>	See Sec. 4.3.4, Building Form Standards for Detached Accessory Structures			
<b>DESIGN ELEMENTS</b>		E-TU-B	E-TU-C	E-RH-2.5; E-MU-2.5	
<b>BUILDING CONFIGURATION</b>					
	Rooftop or Second Story Decks	See Section 4.3.5.2, Rooftop or Second Story Decks			
	Attached Garage Allowed	(1) Shall not be located closer to the minimum Primary Street Zone Lot Line than the Primary Street-facing Façade(s) comprising at least 65% of the total width of the primary structure enclosing the primary use. (2) May follow the General Detached Structure building form for Side Street, Side Interior and Rear setbacks provided no permitted height increase has been applied to the Attached Garage			
	Primary Street Facing Attached Garage Door Width in front 50% of zone lot depth(max)	35% of the entire width of the Primary Street-facing Façade of the dwelling primary structure or 16', whichever is greater			
	Upper Story Stepback, for any portion of building with Low-Slope Roof, above 25': Primary Street (min), for Structure #1 and for Structure #2 in front 50% of zone lot depth	10'	10'	10'	
<b>STREET LEVEL ACTIVATION</b>					
M	Pedestrian Access, Primary Street*	Primary Structure #1: Entry Feature Primary Structure #2: No Requirement			
<b>USES</b>		All E-TU, RH, MU Districts			
		Primary Uses shall be limited to Single Unit Dwelling per primary structure. See Division 4.4, Uses, and Required Minimum Parking			

See Sections 4.3.5 - 4.3.7 for Supplemental Design Standards, Design Standard Alternatives, and Design Standard Exceptions.



## ROW HOUSE

### HEIGHT

E-RH-2.5

A	Stories (max)	see below
A	Feet (max)	see below
A	Stories, front 65% / rear 35% of zone lot depth (max)	2.5/1
A	Feet, front 65% / rear 35% of zone lot depth (max)	30' / 19'
	Feet, front 65% of zone lot depth, permitted height increase	1' for every 5' increase in Zone Lot width over 50' up to a maximum height of 35'
B	Side Wall Height, for Pitched Roof, within 15' of Side Interior and Side Street (max)	25'
C	Upper Story Setback, for Low-Slope Roof, Above 25': Side, Interior and Side Street	15'

### SITING

E-RH-2.5

#### ZONE LOT

	Zone Lot Area (min)	6,000 sf
D	Zone Lot Width (min)	50'
	Dwelling Units per Primary Residential Structure (max)	10

#### SETBACKS

E	Primary Street (min)	Calculated per Sec. 13.1.5.9, Determination of Primary Street Setback Offset Distance
F	Side Street (min)	5'
G	Side Interior (min)	5'
	Rear, where Alley (public or private) abuts a Rear Zone Lot Line (min)	12'
	Rear, where Alley (public or private) does not abut a Rear Zone Lot Line (min)	20'
	Rear, where a Protected District abuts a Rear Zone Lot Line and where Alley (public or private) does not abut the Rear Zone Lot Line adjacent to Protected District	na

#### PARKING

	Surface Parking between building and Primary Street/Side Street	Not Allowed/Allowed
	Vehicle Access	From Alley; or Street access allowed when no Alley present

#### DETACHED ACCESSORY STRUCTURES

See Sec. 4.3.4, Building Form Standards for Detached Accessory Structures

### DESIGN ELEMENTS

E-RH-2.5

#### BUILDING CONFIGURATION

H	Dwelling Units Oriented to the Street	All Dwelling Units shall be Oriented to the Street
	Dwelling Unit Configuration	Structure shall only contain Side-by-Side Dwelling Units
I	Upper Story Stepback, for any portion of building with Low-Slope Roof, above 25': Primary Street (min)	10'
J	Primary Street- Facing Attached Garage Door Width (max per unit)	10'
	Rooftop or Second Story Decks	See Sec. 4.3.5.2, Rooftop or Second Story Decks
	Attached Garage Allowed	May follow the General Detached Structure building form Side Street, Side Interior and Rear setbacks

#### STREET LEVEL ACTIVATION

K	Pedestrian Access	Each unit shall have a street-facing Entrance
---	-------------------	---

### USES

E-RH-2.5

Primary Uses shall be limited to Multi-Unit Dwelling and permitted Congregate Living, Residential Care and Non-residential uses. See Division 4.4, Uses **and Required Minimum Parking**.

See Sections 4.3.5 - 4.3.7 for Supplemental Design Standards, Design Standard Alternatives, and Design Standard Exceptions.

## GARDEN COURT

### HEIGHT

#### E-MU-2.5

A	Stories, front 65% / rear 35% of zone lot depth (max)	2.5/1
A	Feet, front 65% / rear 35% of zone lot depth (max)	30'/19'
	Feet, front 65% of zone lot depth, permitted height increase	1' for every 5' increase in Zone Lot width over 50' up to a maximum height of 35'
	Side Wall Height, for Pitched Roof, within 15' of Side Interior and Side Street (max)	25'
B	Upper Story Setback, for Low-Slope Roof, above 25': Side, Interior and Side Street	15'

### SITING

#### E-MU-2.5

#### ZONE LOT

	Zone Lot Area (min)	9,000 sf
C	Zone Lot Width (min)	75'
	Dwelling Units per Primary Residential Structure (max)	10

#### SETBACKS

D	Primary Street (min)	Calculated per Sec. 13.1.5.9, Determination of Primary Street Setback Offset Distance, or 20', whichever is less
E	Side Street (min)	5'
F	Side Interior (min)	5'
	Rear, where Alley (public or private) abuts a Rear Zone Lot Line (min)	12'
	Rear, where Alley (public or private) does not abut a Rear Zone Lot Line (min)	20'
G	Required Separation Between Primary Structures (min)	10'

#### PARKING

	Surface Parking between building and Primary Street/Side Street	Not Allowed/Allowed
H	Off-Street Parking Area	Shall be setback a minimum of 50' from the Primary Street
	Surface Parking Screening	See Division 10.5, Landscaping, Fences, Walls and Screening
	Vehicle Access	From Alley; or Street access allowed when no Alley present

#### DETACHED ACCESSORY STRUCTURES

See Sec. 4.3.4, Bldg. Form Std.s for Detached Accessory Structures

### DESIGN ELEMENTS

#### E-MU-2.5

#### BUILDING CONFIGURATION

I	Upper Story Stepback, for any portion of building with Low-Slope Roof, above 25': Primary Street (min)	10'
J	Street-Facing Garden Court Width, (min)	30' or 33% of Zone Lot width, whichever is greater.
K	Street-Facing Garden Court Depth (min)	30'
	Garden Court Design Standards	See Sec. 4.3.5.3, Garden Court
	Rooftop or Second Story Decks	See Section 4.3.5.2, Rooftop or Second Story Decks
	Attached Garage Allowed	May follow the General Detached Structure building form Side Street, Side Interior and Rear setbacks provided no permitted height increase has been applied to the Attached Garage

#### STREET LEVEL ACTIVATION

L	Pedestrian Access	Each dwelling unit shall have a Street Level Entrance. A minimum of two dwelling units shall have a Dwelling Unit Entrance with Entry Feature facing the Primary Street and all other dwelling units shall have an Entrance that faces either the Primary Street or the interior Garden Court
M	Transparency, Primary Street (min)	30%
	Transparency, Side Street (min)	25%

### USES

Primary Uses shall be limited to Two Unit Dwelling and Multi Unit Dwelling (3+). See Division 4.4, Uses **and Required Minimum Parking**.

See Sections 4.3.5 - 4.3.7 for Supplemental Design Standards, Design Standard Alternatives, and Design Standard Exceptions.

## TOWN HOUSE (MULTI UNIT DISTRICTS)

<b>HEIGHT</b>		<b>E-MU-2.5</b>
<b>A</b>	Stories, front 65% / rear 35% of Zone Lot depth (max)	2.5/1
<b>A</b>	Feet, front 65% / rear 35% of Zone Lot depth (max)	30'/19'
	Feet, front 65% of Zone Lot depth, permitted height increase	1' for every 5' increase in Zone Lot width over 50' up to a maximum height of 35'
<b>B</b>	Side Wall Height, for Pitched Roof, within 15' of Side Interior and Side Street (max)	25'
<b>C</b>	Upper Story Setback, for Low-Slope Roof, above 25': Side, Interior and Side Street	15'
<b>SITING</b>		<b>E-MU-2.5</b>
<b>ZONE LOT</b>		
	Zone Lot Area (min)	6,000 sf
<b>D</b>	Zone Lot Width (min)	50'
<b>REQUIRED BUILD-TO</b>		
<b>E</b>	Primary Street (min build-to % within min/max range)	70% 20'/25'
<b>SETBACKS</b>		
<b>F</b>	Primary Street (min)	Calculated per Sec. 13.1.5.9, Determination of Primary Street Setback Offset Distance, or 20', whichever is less
<b>G</b>	Side Street (min)	7.5'
<b>H</b>	Side Interior, except Dwelling Units Oriented to the Street (min)	10'
<b>I</b>	Side Interior, for Dwelling Units Oriented to the Street (min)	5'
	Rear, where Alley (public or private) abuts a Rear Zone Lot Line (min)	12'
	Rear, where Alley (public or private) does not abut a Rear Zone Lot Line (min)	20'
<b>PARKING</b>		
	Surface Parking between building and Primary Street/Side Street	Not Allowed/Allowed
	Vehicle Access	From Alley; or Street access allowed when no Alley present
<b>DESIGN ELEMENTS</b>		<b>E-MU-2.5</b>
<b>BUILDING CONFIGURATION</b>		
<b>J</b>	Dwelling Units Oriented to the Street	Required if any portion of the Dwelling Unit is located within 30' of Primary Street Zone Lot Line or 20' of the Side Street Zone Lot Line.
	Dwelling Unit Configuration	Structure may contain Side-by-Side Dwelling Units
<b>STREET LEVEL ACTIVATION</b>		
<b>K</b>	Transparency, Primary Street (min)	40%
	Transparency, Side Street (min)	25%
<b>L</b>	Pedestrian Access	Each Dwelling Unit Oriented to the Street shall have Dwelling Unit Entrance with Entry Feature
<b>USES</b>		<b>E-MU-2.5</b>
		Primary Uses shall be limited to Two Unit Dwelling and Multi Unit Dwelling (3+) uses. See Division 4.4, <u>Uses, and Required Minimum Parking</u>
See Sections 4.3.5 - 4.3.7 for Supplemental Design Standards, Design Standard Alternatives, and Design Standard Exceptions.		

## TOWN HOUSE (MIXED USE DISTRICTS)

				E-MX-2x	E-MX-3A	E-MS-2x		
		E-RX-3	E-RX-5	E-MX-2A	E-MX-3	E-MS-2	E-MS-3	E-MS-5
<b>HEIGHT</b>				E-MX-2	E-MX-3	E-MS-2	E-MS-3	E-MS-5
<b>A</b>	Stories (max)	3	5	2	3	2	3	5
<b>A</b>	Feet (min/max)	na/38'	na/70'	na/30'	na/38'	na/30'	na/38'	24'/70'
				E-MX-2x <th>E-MX-3A</th> <th>E-MS-2x</th> <td colspan="2"></td>	E-MX-3A	E-MS-2x		
		E-RX-3	E-RX-5	E-MX-2A	E-MX-3	E-MS-2	E-MS-3	E-MS-5
<b>SITING</b>				E-MX-2	E-MX-3	E-MS-2	E-MS-3	E-MS-5
<b>REQUIRED BUILD-TO</b>				E-MX-2	E-MX-3	E-MS-2	E-MS-3	E-MS-5
<b>B</b>	Primary Street (min build-to % within min/max range)	70%	70%	70% 10'/15'	70%	75%	75%	75%
	Side Street (min build-to % within min/max range)	na	na	na	na	25%	25%	25%
						7.5'/15'	7.5'/15'	7.5'/15'
<b>SETBACKS</b>				E-MX-2	E-MX-3	E-MS-2	E-MS-3	E-MS-5
<b>C</b>	Primary Street (min)	10'	10'	10'	10'	10'	10'	10'
<b>D</b>	Side Street (min)	7.5'	7.5'	7.5'	7.5'	7.5'	7.5'	7.5'
<b>E</b>	Side Interior (min)	5'	5'	5'	5'	5'	5'	5'
<b>F</b>	Side Interior, adjacent to Protected District (min)			E-MX-2x and E-MS-2x: 5'		All other Zone Districts: 10'		
	Rear (min)	0'	0'	0'	0'	0'	0'	0'
	Rear, Adjacent to Protected District, where Alley (public or private) abuts a Rear Zone Lot Line (min)			E-MX-2x and E-MS-2x: 12'		All other Zone Districts: 0'		
	Rear, Adjacent to Protected District, where Alley (public or private) does not abut a Rear Zone Lot Line (min)			E-MX-2x and E-MS-2x: 20'		All other Zone Districts: 10'		
<b>PARKING</b>				E-MX-2	E-MX-3	E-MS-2	E-MS-3	E-MS-5
	Surface Parking between building and Primary Street			Not Allowed				
	Surface Parking between building and Side Street			Allowed				
	Vehicle Access			From Alley; or Street access allowed when no Alley present				
				E-MX-2x <th>E-MX-3A</th> <th>E-MS-2x</th> <td colspan="2"></td>	E-MX-3A	E-MS-2x		
		E-RX-3	E-RX-5	E-MX-2A	E-MX-3	E-MS-2	E-MS-3	E-MS-5
<b>DESIGN ELEMENTS</b>				E-MX-2	E-MX-3	E-MS-2	E-MS-3	E-MS-5
<b>BUILDING CONFIGURATION</b>				E-MX-2	E-MX-3	E-MS-2	E-MS-3	E-MS-5
<b>G</b>	Dwelling Units Oriented to the Street	Required if any portion of the Dwelling Unit is located within 20' of Primary Street Zone Lot Line or 20' of the Side Street Zone Lot Line.						
	Dwelling Unit Configuration	Structure may contain Side-by-Side Dwelling Units						
<b>H</b>	Upper Story Setback Above 27', adjacent to Protected District: Rear, alley/ Rear, no alley and Side Interior (min)	15'/25'	20'/25'	na	na	na	15'/25'	20'/25'
	Upper Story Setback Above 51', adjacent to Protected District: Rear, alley/ Rear, no alley and Side Interior (min)	na	35'/40'	na	na	na	na	35'/40'
<b>STREET LEVEL ACTIVATION</b>				E-MX-2	E-MX-3	E-MS-2	E-MS-3	E-MS-5
<b>I</b>	Transparency, Primary Street (min)			40%				
	Transparency, Side Street (min)			25%				
<b>J</b>	Pedestrian Access	Each Dwelling Unit Oriented to the Street shall have Dwelling Unit Entrance with Entry Feature						
<b>USES</b>				E-MX-2	E-MX-3	E-MS-2	E-MS-3	E-MS-5
	Street Level Active Uses (min % of Primary Street frontage meeting Build-To requirement)			All E-RX Districts		All E-MX Districts		All E-MS Districts
				na		na		100%
		Primary Uses shall be limited to Two Unit Dwelling and Multi Unit Dwelling (3+) uses. See Division 4.4, Uses, <a href="#">and Required Minimum Bicycle Parking</a>						

See Sections 4.3.5 - 4.3.7 for Supplemental Design Standards, Design Standard Alternatives, and Design Standard Exceptions.

## APARTMENT

### HEIGHT

E-MU-2.5

A	Stories, front 65% / rear 35% of zone lot depth (max)	2/1
A	Feet, front 65% / rear 35% of zone lot depth (max)	30'/19'
	Feet, front 65% of zone lot depth, permitted height increase	1' for every 5' increase in Zone Lot width over 50' up to a maximum height of 35'
	Side Wall Height, for Pitched Roof, within 15' of Side Interior and Side Street (max)	25'
	Upper Story Setback, for Low-Slope Roof, Above 25': Side Interior and Side Street (min)	15'

### SITING

E-MU-2.5

#### ZONE LOT

	Zone Lot Area (min)	6,000 sf
	Zone Lot Width (min)	50'

#### SETBACKS

B	Primary Street (min)	Calculated per Sec. 13.1.5.9, Determination of Primary Street Setback Offset Distance, or 20', whichever is less
C	Side Street (min)	5'
D	Side Interior (min)	5'
E	Rear, where Alley (public or private) abuts a Rear Zone Lot Line (min)	12'
E	Rear, where Alley (public or private) does not abut a Rear Zone Lot Line (min)	20'

#### PARKING

	Surface Parking between building and Primary Street/Side Street	Not Allowed/Allowed
	Surface Parking Screening	See Division 10.5, Landscaping, Fences, Walls and Screening
	Vehicle Access	Access determined at Site Development Plan

### DESIGN ELEMENTS

E-MU-2.5

#### BUILDING CONFIGURATION

	Dwelling Unit Configuration	Structure may contain Side-by-Side Dwelling Units Residential Only Structure: Side-by-Side Dwelling Units shall not exceed 50% of the Structure's GFA
	Street facing garage door width per Primary Structure (max)	20'
	Upper Story Stepback, for any portion of building with Low-Slope Roof, above 25': Primary Street (min)	10'
	Rooftop or Second Story Decks	See Section 4.3.5.2, Rooftop or Second Story Decks

#### STREET LEVEL ACTIVATION

G	Transparency, Primary Street (min)	40%
H	Transparency, Side Street (min)	25%
I	Pedestrian Access, Primary Street	Entrance

### USES

E-MU-2.5

Primary Uses shall be limited to Multi Unit Dwelling (3+) and permitted Congregate Living, Residential Care and Nonresidential uses. See Division 4.4, [Uses, and Required Minimum Parking](#)

See Sections 4.3.5 - 4.3.7 for Supplemental Design Standards, Design Standard Alternatives, and Design Standard Exceptions.

## DRIVE THRU SERVICES

APPLICABILITY		All E-CC, E-MX, E-MS		
Form is not permitted on Zone Lots within 1/4 mile of the outer boundary of a Rail Transit Station Platform				
HEIGHT	E-CC-3, -3x	E-MX-2 -2A E-MS-2	E-MX-3, 3A E-MS-3, -5	
Stories (max)	3	2	3	
Feet (max)	45'	30'	45'	
SITING	E-CC-3, -3x	E-MS-2, -3, -5 E-MX-2A, -3A Option A	E-MX-2, -3 E-MX-2A, 3A** Option B	
REQUIRED BUILD-TO				
Primary Street (min % within min/max)*	na	50% 0'/15'	na	
Side Street (min % within min/max)*	na	50% 0'/15'	na	
SETBACKS				
Primary Street (min)	0'	0'	0'	
Side Street (min)	0'	0'	0'	
A Side Interior (min)	0'	0'	0'	
Side Interior, adjacent to Protected District (min)	10'	10'	10'	
Rear (min)	0'	0'	0'	
Rear, adjacent to Protected District, where Alley (public or private) abuts a Rear Zone Lot Line (min)	0'	0'	0'	
Rear, adjacent to Protected District, where Alley (public or private) does not abut a Rear Zone Lot Line (min)	10'	10'	10'	
PARKING				
B Surface Parking between building and Primary Street/Side Street	Allowed/Allowed	Not Allowed/Not Allowed	Allowed/Allowed	
DESIGN ELEMENTS	E-CC-3, -3x	E-MS-2, -3, -5 E-MX -2A, -3A Option A	E-MX-2, -3 E-MX-2A, 3A** Option B	
BUILDING CONFIGURATION				
C *Canopy	na	Building shall be used to meet a portion of the Primary and Side Street Build-To. Canopy may be used to meet a portion of the Primary and Side Street Build-To.	na	
D Screening Required	See Article 10	Garden Wall required within 0'/15' for 100% of the zone lot's Primary and Side Street frontages, excluding access points and portions of building within 0'/15', following the standards of Section 10.5.4.4, Perimeter Surface Parking Lot Landscaping Standards		
Upper Story Setback Above 27', adjacent to Protected District: Rear, alley/ Rear, no alley and Side interior (min)	15'/25'	15'/25'	15'/25'	
STREET LEVEL ACTIVATION				
E Transparency, Primary Street (min)	40%	40% E-MS: 60%	40%	
F Transparency, Side Street (min)	25%	25%	25%	
G Pedestrian Access, Primary Street	Pedestrian Connection	Entrance	Pedestrian Connection	
USES	All E-CC;	E-MX-2, -2A, -3, -3A; E-MS-2, -3, -5		
	All permitted Primary Uses shall be allowed within this building form, provided that the building form includes a minimum of one Automobile Services, Light or Primary Use with Accessory Drive Thru Uses, excluding Eating/Drinking Establishments. See Division 4.4, Uses <b>and Required Minimum Parking.</b>	For Primary Structures constructed on or before June 25, 2010, all permitted Primary Uses shall be allowed within this building form; however, for Primary Structures constructed after June 25, 2010, Primary Uses shall be limited to Automobile Services, Light or Primary Use with Accessory Drive Thru Use, excluding Eating & Drinking Establishments. See Division 4.4, Uses <b>and Required Minimum Parking.</b> **Additionally, in E-MX-2A, 3A Option B is limited to Gasoline Service Station Use Only		

See Sections 4.3.5 - 4.3.7 for Supplemental Design Standards, Design Standard Alternatives, and Design Standard Exceptions.

## DRIVE THRU RESTAURANT

### APPLICABILITY

All E-CC, E-MX, E-MS

Form is not permitted on Zone Lots within 1/4 mile of the outer boundary of a Rail Transit Station Platform

### HEIGHT

	E-CC-3, -3x	E-MX-2, -2A, E-MS-2	E-MX-3, -3A E-MS-3, -5
Stories (max)	3	2	3
Feet (max)	45'	30'	45'

### SITING

#### REQUIRED BUILD-TO

	E-CC-3, -3x	E-MX-2 -2A, -3, -3A E-MS-2 -3, -5
Primary Street (min % within min/max)	50% 0'/80'	50% 0'/35'
Side Street (min % within min/max)	na	50% 0'/18'

#### SETBACKS

	E-CC-3, -3x	E-MX-2 -2A, -3, -3A E-MS-2 -3, -5
Primary Street (min)	0'	0'
Side Street (min)	0'	0'
Side Interior (min)	0'	0'
Side Interior, adjacent to Protected District (min)	10'	10'
Rear (min)	0'	0'
Rear, adjacent to Protected District, where Alley (public or private) abuts a Rear Zone Lot Line (min)	0'	0'
Rear, adjacent to Protected District, where Alley (public or private) does not abut a Rear Zone Lot Line (min)	10'	10'

#### PARKING

	Surface Parking between building and Primary Street/Side Street	Allowed/Allowed	Not Allowed/Not Allowed
A	Drive Thru Lane between building and Primary Street/Side Street	Allowed/Allowed	Allowed/Allowed
	Drive Thru Lane Width (max)	na	12'
B	Drive Thru Screening	na	Garden Wall, following the standards of Section 10.5.4.4, Perimeter Surface Parking Lot Landscaping Standards

### DESIGN ELEMENTS

#### BUILDING CONFIGURATION

	E-CC-3, -3x	E-MX-2, -2A, E-MS-2	E-MX-3, -3A E-MS-3, -5
Upper Story Setback Above 27', adjacent to Protected District: Rear, alley/ Rear, no alley and Side interior (min)	15'/25'	na	15'/25'

#### STREET LEVEL ACTIVATION

C	Transparency, Primary Street (min)	40%	40% E-MS: 60%	40% E-MS: 60%
D	Transparency, Side Street (min)	25%	25%	25%
E	Pedestrian Access, Primary Street	Pedestrian Connection	Entrance and Pedestrian Connection	

### USES

All E-CC;

E-MX-2, -2A, -3, -3A; E-MS-2, -3, -5

All permitted Primary Uses shall be allowed within this building form, provided that the building form includes a minimum of one Eating/ Drinking Establishment Primary Use with Accessory Drive Thru Use. See Division 4.4, Uses, and Required Minimum Parking

For Primary Structures constructed on or before June 25, 2010, all permitted Primary Uses shall be allowed within this building form; however, for Primary Structures constructed after June 25, 2010, Primary Uses shall be limited to an Eating & Drinking Establishment Primary Use with Accessory Drive Thru Use Only. See Division 4.4, Uses, and Required Minimum Parking

See Sections 4.3.5 - 4.3.7 for Supplemental Design Standards, Design Standard Alternatives, and Design Standard Exceptions.

## GENERAL (1 OF 2)

<b>HEIGHT</b>		<b>E-CC-3, -3x</b>	
Stories (max)		3	
Feet (max)		45'	
Stories/Feet, with incentives (max)		4/55'	
Height Exceptions		See Section 10.12.1, Height Incentives See Section 4.3.7.1, Height Exceptions	
<b>SITING</b>		<b>E-CC-3, -3x Option A</b>	<b>E-CC-3, -3x Option B</b>
<b>RESTRICTION</b>		na	Allowed only if Street Level GFA is greater than 20,000 sf
<b>REQUIRED BUILD-TO</b>			
<b>A</b> Primary Street (min build-to % within min/max range)		50% 0'/80'	na
Build-to Exceptions and Alternatives		See Section 13.1.5.7.D, Required Build-To Exceptions, and Section 4.3.6.1, Required Build-To Alternatives	na
<b>SETBACKS</b>			
Primary Street (min)		0'	0'
Side Street (min)		0'	0'
Side Interior (min)		0'	0'
<b>B</b> Side Interior, adjacent to Protected District (min)		10'	10'
Rear (min)		0'	0'
Rear, adjacent to Protected District, where Alley (public or private) abuts a Rear Zone Lot Line (min)		0'	0'
Rear, adjacent to Protected District, where Alley (public or private) does not abut a Rear Zone Lot Line (min)		10'	10'
<b>PARKING</b>			
<b>C</b> Surface Parking between building and Primary Street/Side Street		Allowed/Allowed	
<b>D</b> Surface Parking Screening		See Division 10.5, Landscaping, Fences, Walls and Screening	
Vehicle Access, 3 or more side-by-side dwelling units in one structure		From Alley; or Street access allowed when no Alley present according to Section 4.3.7.5, Vehicle Access From Alley Required - Exceptions	
Vehicle Access, all other permitted uses		Access determined at Site Development Plan	
<b>DESIGN ELEMENTS</b>		<b>E-CC-3, -3x Option A</b>	<b>E-CC-3, -3x Option B</b>
<b>BUILDING CONFIGURATION</b>			
<b>E</b> Upper Story Setback Above 27', adjacent to Protected District: Rear, alley/ Rear, no alley and Side interior (min)		15'/25'	15'/25'
<b>STREET LEVEL ACTIVATION</b>			
<b>F</b> Transparency, Primary Street (min)		40%	40%*
		Residential Only Buildings: 30%	Residential Only Buildings: 30%*
<b>G</b> Transparency, Side Street (min)		25%	25%*
Transparency Alternatives		See Section 4.3.6.2, Transparency Alternatives	
<b>H</b> Pedestrian Access, Primary Street		Pedestrian Connection	
<b>USES</b>		<b>E-CC-3, -3x</b>	
All permitted Primary Uses shall be allowed within this building form. See Division 4.4. Uses, <b>and Required Minimum Parking</b>			

\*Applies only to street-facing portions of building facade located within 80' of the Primary or Side Street

See Sections 4.3.5 - 4.3.7 for Supplemental Design Standards, Design Standard Alternatives, and Design Standard Exceptions.



## GENERAL (2 OF 2)

<b>HEIGHT</b>		E-MX-2, -2A, -2x	E-MX-3, -3A	
Stories (max)		2	3	
Feet (max)		30'	45'	
Stories/Feet, with incentives (max)		na	4/55' See Section 10.12.1, Height Incentives	
<b>SITING</b>		E-MX-2, -2A, -2x E-MX-3, -3A Option A	E-MX-2, -2A, -2x E-MX-3, -3A Option B	E-MX-2, -2x -3 Option C
<b>REQUIRED BUILD-TO</b>				
<b>A</b>	Primary Street (min build-to % within min/max range)	70% 0'/15'	70% 0'/15'	70% 0'/80'
<b>B</b>	Side Street (min build-to % within min/max range)	na	na	25% 0'/15'
<b>SETBACKS</b>				
	Primary Street (min)	0'	0'	0'
	Side Street (min)	0'	0'	0'
	Side Interior (min)	0'	0'	0'
<b>C</b>	Side Interior, adjacent to Protected District (min)	E-MX-2x: 5' 10'	10'	10'
	Rear (min)	0'	0'	0'
	Rear, adjacent to Protected District, where Alley (public or private) abuts a Rear Zone Lot Line (min)		E-MX-2x, E-MS-2x: 12' All Other Zone Districts: 0'	
	Rear, adjacent to Protected District, where Alley (public or private) does not abut a Rear Zone Lot Line (min)		E-MX-2x, E-MS-2x: 20' All Other Zone Districts: 10'	
<b>PARKING</b>				
<b>D</b>	Surface Parking between building and Primary Street/ Side Street	Not Allowed/ Allowed	Not Allowed/ Allowed	Allowed/ Not Allowed
<b>E</b>	Surface Parking Screening	See Division 10.5, Landscaping, Fences, Walls and Screening		
	Vehicle Access	Access determined at Site Development Plan		
<b>DESIGN ELEMENTS</b>		E-MX-2, -2A, -2x E-MX-3, -3A Option A	E-MX-2, -2A, -2x E-MX-3, -3A Option B	E-MX-2, -2x -3 Option C
<b>BUILDING CONFIGURATION</b>				
	Dwelling Unit Configuration	Structure may contain Side-by-Side Dwelling Units Residential Only Structure: Side-by-Side Dwelling Units shall not exceed 50% of the Structure's GFA		
<b>F</b>	Overall Structure Length, Primary Street (max)	na	150'	na
<b>G</b>	Upper Story Setback Above 27', adjacent to Protected District: Rear, alley/ Rear, no alley and Side interior (min)	MX-3, -3A Only: 15'/25'	MX-3, -3A Only: 15'/25'	MX-3 Only: 15'/25'
<b>STREET LEVEL ACTIVATION</b>				
<b>H</b>	Transparency, Primary Street (min)	40%	40%	60%
<b>I</b>	Transparency, Side Street (min)	25%	25%	25%
<b>J</b>	Pedestrian Access, Primary Street	Entrance	Entrance or Pedestrian Connection	Pedestrian Connection
<b>USES</b>		E-MX-2x, -2A, -2, -3, -3A		
(1) All permitted Primary Uses shall be allowed within this building form See Division 4.4, Uses and Required Minimum Parking; and (2) 40% of the street-facing portions of building façade located within 80' of the Primary Street shall be occupied by Street Level active uses as described in Section 4.3.5.4, Street Level Active Uses in the E-MX and E-MS Zone Districts				

See Sections 4.3.5 - 4.3.7 for Supplemental Design Standards, Design Standard Alternatives and Design Standard Exceptions

# SHOPFRONT

	E-RX-3	E-RX-5	E-MS-2x E-MS-2 E-MX-2x E-MX-2A E-MX-2	E-MS-3 E-MX-3A E-MX-3	E-MS-5
<b>HEIGHT</b>					
Stories (max)	3	5	2	3	5
<b>A</b> Feet (min/max)	na/45'	na/70'	na/30'	na/45'	24'/70'
Stories/Feet, with incentives (max)	4/55'	7/95'	na	4/55'	7/95'
Feet, within 175' of Protected District (max)	na	75'	na	na	75'
See Section 10.12.1, Height Incentives					
<b>SITING</b>					
<b>REQUIRED BUILD-TO</b>					
<b>B</b> Primary Street (min build-to % within min/max range)	70% 0'/15'	70% 0'/15'	75% 0'/5' Residential Only Buildings: 0'/10'		
<b>C</b> Side Street (min build-to % within min/max range)	na	na	25% 0'/5' Residential Only Buildings: 0'/10'		
<b>SETBACKS</b>					
Primary Street (min)	0'	0'	0'		
Side Street (min)	0'	0'	0'		
Side Interior (min)	0'	0'	0'		
<b>D</b> Side Interior, adjacent to Protected District (min)	10'	10'	E-MS-2x: 5' 10'		
Rear (min)	0'	0'	0'		
Rear, adjacent to Protected District, where an Alley (public or private) abuts a Rear Zone Lot Line (min)	0'	0'	E-MS-2x, E-MX-2x: 12' All Other Zone Districts: 0'		
Rear, adjacent to Protected District, where an Alley (public or private) does not abut a Rear Zone Lot Line (min)	10'	10'	E-MS-2x, E-MX-2x: 20' All Other Zone Districts: 10'		
<b>PARKING</b>					
Surface Parking between building and Primary Street/Side Street	Not Allowed /Not Allowed				
Vehicle Access	Shall be determined as part of Site Development Plan Review				
<b>DESIGN ELEMENTS</b>					
<b>BUILDING CONFIGURATION</b>					
Dwelling Unit Configuration	Structure may contain Side-by-Side Dwelling Units Residential Only Structure: Side-by-Side Dwelling Units shall not exceed 50% of the Structure's GFA				
<b>F</b> Upper Story Setback Above 27', adjacent to Protected District: Rear, alley/ Rear, no alley and Side Interior (min)	15'/25'	20'/25'	na	15'/25'	20'/25'
<b>G</b> Upper Story Setback Above 51', adjacent to Protected District: Rear, alley/ Rear, no alley and Side Interior (min)	na	35'/40'	na	na	35'/40'
<b>STREET LEVEL ACTIVATION</b>					
<b>H</b> Transparency, Primary Street (min)	60% Residential Only Buildings: 40%			60% Residential Only Buildings: 40%	
<b>I</b> Transparency, Side Street (min)	25%			25%	
<b>J</b> Pedestrian Access, Primary Street	Entrance				
<b>USES</b>					
Street Level Active Uses (min % of Primary Street frontage meeting Build-To requirement)	All E-RX Districts na			All E-MS and E-MX Districts 100%	
Permitted Primary Uses	All permitted Primary Uses shall be allowed within this building form; however: (1) Second Story and Above: Residential or Lodging Accommodations Uses Only; and (2) Buildings with No Residential or Lodging Accommodation Uses: 10,000 sf GFA max			All permitted Primary Uses shall be allowed within this building form. See Division 4.4, Uses, and Required Minimum Parking	

See Sections 4.3.5 - 4.3.7 for Supplemental Design Standards, Design Standard Alternatives, and Design Standard Exceptions.

## DETACHED ACCESSORY DWELLING UNIT

		All E-SU		
<b>HEIGHT</b>		Option A: 1-story*	Option B: 2-stories*	All E-TU, RH, MU, RX, MX, MS
A	Stories (max)	1	2	2
A	Feet (max)	17'	24'	24'
B	Bulk Plane Vertical Height at Side Interior Zone Lot Line	Lots 40' wide or less: 12'; Lots greater than 40' wide: 10'		
	Bulk Plane Slope from Side Interior Zone Lot Line	45°		

		All E-SU		
<b>SITING</b>		Option A: 1-story*	Option B: 2-stories*	All E-TU, RH, MU, RX, MX, MS
<b>SETBACKS</b>				
	Location of Structure	Located in the rear 35% of the zone lot depth		
		Option A: 1-story*	Option B: 2-stories*	
C	Side Interior and Side Street for lots 40' wide or less (min)	3'	3'	3'
C	Side Interior and Side Street for lots greater than 40' wide (min)	5'	5'	5'
D	Rear, where Alley (public or private) or Street abuts Rear Zone Lot Line (min)	5'	5'	5'
E	Rear, where Alley (public or private) or Street does not abut Rear Zone Lot Line (min)	5'	12'	5'
	Maximum Building Coverage per Zone Lot	See maximum Building Coverage per Zone Lot in the Primary Structure building form table.		
<b>PARKING</b>				
	Vehicle Access**	From Alley (public or private); or Street access allowed when no Alley present See Sec. 4.3.7.5, Vehicle Access From Alley Required - Exceptions, for exceptions		

		All E-SU By Zone Lot Area		
<b>DESIGN ELEMENTS</b>		7,000 sf or Less	Greater than 7,000 sf	All E-TU, RH, MU, RX, MX, MS
<b>BUILDING CONFIGURATION</b>				
	Building Footprint (max)	864 sf per unit	1,000 sf per unit	1,000 sf per unit
	Limitation on Gross Floor Area of a Accessory Dwelling Unit Use	See Section 11.8, Uses Accessory to Primary Residential Uses - Limitations		
	Rooftop or Second Story Decks, where no Alley (public or private) abuts a Rear Zone Lot Line	Not allowed - See Section 4.3.5.2, Rooftop or Second Story Decks		
	Rooftop or Second Story Decks, where Alley (public or private) abuts a Rear Zone Lot Line	Allowed - See Section 4.3.5.2, Rooftop or Second Story Decks		

<b>USES</b>		All E-SU, TU, RH, MU, RX, MX, MS
		An Accessory Dwelling Unit use must be concurrently permitted and approved for occupancy in this building form. The Accessory Dwelling Unit use may be combined with other uses Accessory to Primary Residential Uses. See Division 4.4, Uses <b>and Required Minimum Parking</b> , for permitted Uses Accessory to Primary Residential Uses

See Sections 4.3.5 - 4.3.7 for Supplemental Design Standards, Design Standard Alternatives and Design Standard Exceptions

\*Standards in the "Option A" column may not be combined with standards in the "Option B" column. For example, If using Option B height standards to construct a two-story structure, the structure must also follow the Option B siting standards that require a minimum 12' rear setback where there is no Alley abutting the Rear Zone Lot Line.

\*\* See Section 10.4.6, Vehicle Parking Design for standards that may be more restrictive.

## GENERAL DETACHED STRUCTURE

Examples of General Detached Structures include garages, sheds, and gazebos. The General Detached Structure building form provides standards for structures accessory to a primary structure that exceed the standards for a Minor Detached Structure building form.

<b>HEIGHT</b>		All E-SU, TU, RH, MU	All E-CC, MX, RX, MS		
A	Stories (max)	1	1		
A	Feet (max)	17'	17'		
B	Bulk Plane Vertical Height at Side Interior and Side Street Zone Lot Line	10'	na		
	Bulk Plane Slope from Side Interior and Side Street Zone Lot Line	45°	na		
<b>SITING</b>		All E-SU, TU, RH, MU	All E-CC, MX, RX, MS		
<b>SETBACKS</b>					
C	Location of Structure	Located a minimum of 10' behind 75% of the total width of the Primary Street-facing facade(s) of one Primary Structure; see Section 13.1.5.12, Location of Structure for Minor Detached Structure Building Form and General Detached Structure Building Form, for applicable location standard when there are multiple Primary Structures on one Zone Lot			
D	Side Street (min)	5'	5'		
D	Side Interior (min), for structure entirely in rear 35% of zone lot*	0'	5'		
D	Side Interior (min), for structure not entirely in rear 35% of zone lot	5'	5'		
	Side Interior (min), for structure not entirely in rear 35% of zone lot, where Zone Lot Width is 30' or less	3'	5'		
E	Rear, where Alley (public or private) does not abut a Rear Zone Lot Line (min)	5'	5'		
E	Rear, where Alley (public or private) abuts a Rear Zone Lot Line and where garage doors face alley (min)	5'	5'		
E	Rear, where Alley (public or private) abuts a Rear Zone Lot Line and where garage doors do not face alley (min)	0'	0'		
	Maximum Building Coverage per Zone Lot	See maximum Building Coverage per Zone Lot in the Primary Structure building form table			
<b>PARKING</b>					
	Vehicle Access	From Alley (public or private); or Street access allowed when no Alley present; or exceptions according to Sec. 4.3.7.5, Vehicle Access From Alley Required - Exceptions	See Section 10.4.6, Vehicle Parking Design		
<b>DESIGN ELEMENTS</b>		All E-SU	All E-TU	All E-RH, MU	All E-CC, MX, RX, MS
<b>BUILDING CONFIGURATION</b>					
	Building Footprint (max)	1,000 sf	1000 sf per unit	1000 sf per unit	na
	Gross Floor Area (max)	na	na	na	See Sec. 4.3.4.3.C
F	Overall Structure Length (max)	36'	36' per unit	no max	no max
G	Allowed Number of Primary Street Facing Vehicular Access Doors in the front 50% of the lot depth (max)	3	3	3	na
G	Cumulative Width of All Primary Street Facing Vehicular Access Doors in the front 50% of the lot depth (max)	28'	28'	no max	na
<b>USES</b>		All E-SU, TU, RH, MU, CC, MX, RX, MS			
Accessory Uses Only, excluding accessory dwelling unit where permitted. See Division 4.4, Uses and Required Minimum Parking, for permitted Accessory Uses and Parking.					

See Sections 4.3.5 - 4.3.7 for Supplemental Design Standards, Design Standard Alternatives, and Design Standard Exceptions.

\*See Section 10.4.6, Vehicle Parking Design for standards that may be more restrictive.

## MINOR DETACHED STRUCTURES

Structures that meet the standards in this building form table are exempt from the requirement to obtain a zoning permit. Examples of Minor Detached Structures include sheds, arbors, play structures, ground-mounted mechanical equipment such as air conditioning units and heat pumps, and other structures that are similarly minor in impact, height, and footprint. Option A is more limited than Option B in height and footprint, but offers more flexibility in siting. Structures that do not meet the standards in the table below shall be reviewed under the General Detached Structure building form.

		All E-SU, TU, RH, MU, RX, MX, MS	
<b>HEIGHT</b>		Option A*	Option B*
A	Stories (max)	1	1
A	Feet (max)	4'	14'

		All E-SU, TU, RH, MU, RX, MX, MS	
<b>SITING</b>		Option A	Option B
Total number of each structure (max)		na	na
<b>LOCATION OF STRUCTURE</b>			
Ground-Mounted Mechanical Equipment	Shall be located a minimum of 10' behind 75% of the total width of the Primary Street-facing Façade**	Shall be located a minimum of 10' behind 75% of the total width of the Primary Street-facing Façade**	
Public Utility Equipment	Allowed anywhere on the Zone Lot		
All Others	Allowed anywhere on the Zone Lot		
<b>SETBACKS</b>			
B	Side Street (min)	5'	5'
C	Side Interior, for structure entirely in rear 35% of zone lot (min)	0'	0'
	Side Interior, for structure not entirely in rear 35% of zone lot (min)	5'	5'
D	Rear, where Alley (public or private) does not abut Rear Zone Lot Line (min)	5'	5'
	Rear, where Alley (public or private) abuts Rear Zone Lot Line (min)	0'	0'
Building Coverage per Zone Lot (max)		See maximum Building Coverage per Zone Lot in the Primary Structure building form table.	

		All E-SU, TU, RH, MU, RX, MX, MS	
<b>DESIGN ELEMENTS</b>		Option A	Option B
<b>BUILDING CONFIGURATION</b>			
E	Structure footprint (max)	12 sf	200 sf

<b>USES</b>		All E-SU, TU, RH, MU, RX, MX, MS
		Accesssssory Uses Only, excluding accessory dwelling unit use and parking and storage of vehicles. See Division 4.4, Uses <del>and Required Minimum Parking</del> , for permitted Accessory Uses.

See Sections 4.3.5 - 4.3.7 for Supplemental Design Standards, Design Standard Alternatives, and Design Standard Exceptions.

\* Standards in the "Option A" column may not be combined with standards in the "Option B" column. For example, If using Option B height standards to construct a 14-foot-tall structure, the structure must also follow the Option B siting standards that require the structure to be located a minimum of 10 feet behind 75% of the Primary Street-facing Façade.

\*\*When there are multiple Primary Structures on one Zone Lot, all Minor Detached Structures shall be located behind 75% of the total width of the Primary Street-facing Façade(s) of at least one Primary Structure. See Section 13.1.5.12, Location of Structure for Minor Detached Structure Building Form and General Detached Structure Building Form, for applicable location standard when there are multiple Primary Structures on one Zone Lot.

BUILDING FEATURES	ZONE DISTRICTS	THE AGGREGATE SHALL NOT EXCEED 33-1/3 PERCENT OF THE AREA OF THE SUPPORTING ROOF	SHALL BE SET BACK FROM THE PERIMETER OF THE BUILDING A MINIMUM OF ONE FOOT HORIZONTALLY FOR EVERY ONE FOOT OF VERTICAL HEIGHT	MAY EXCEED MAXIMUM HEIGHT IN FEET BY:	MAY EXCEED MAXIMUM HEIGHT IN STORIES BY:	MAY PROJECT THROUGH THE BULK PLANE	MAY EXCEED UPPER STORY SETBACK HEIGHT BY
Accessory water tanks	All E-CC, E-MX, E-MS Zone Districts	No	Yes	28'	Not applicable	Any distance	Any distance
Pedestrian bridge	All E- Zone Districts	Not applicable	Not applicable	28'	Any number	Any distance	Any distance

#### 4.3.7.2 Required Build-To Exceptions for Civic, Public & Institutional Uses

##### A. Intent

To accommodate signature entrance architecture, gathering spaces, plazas, or community amenities along the front facades of structures containing civic, public and institutional uses.

##### B. Standard

Structures containing one or more uses in the Civic, Public & Institutional Use Classification are not required to meet the Primary Street and Side Street Build-To standards.

#### 4.3.7.3 Setback Exceptions - Architectural, Site, Service & Utility Elements

##### A. Intent

To allow minor elements to encroach into a setback while maintaining an open and unobstructed minimum setback.

##### B. Standard

Except as specifically allowed below, Setbacks specified in the applicable Building Form tables shall be open and unobstructed.

##### C. Exceptions

The following Structures or portions of Structures are permitted to encroach into the Setbacks subject to the limitations in the tables below. No portion of a Structure that encroaches into the Setbacks shall extend into a required Setback beyond the maximum Setback encroachment distance specified in the tables below, as measured perpendicular to the respective Zone Lot line. Where more than one Setback encroachment is allowed for the same Structure or portion of a Structure, the permitted Setback encroachment distances shall not be cumulative. See "Height Exceptions" for encroachments related to Upper Story Setbacks.

##### 1. Architectural Elements

To allow for minor elements which add to the architectural character of buildings, while maintaining an open and unobstructed setback.

**2. Site Elements**

To allow for minor screening and parking elements while maintaining an open and unobstructed setback.

	ZONE DISTRICTS	BUILDING FORMS	PRIMARY STREET	SIDE STREET	SIDE INTERIOR	REAR
Fences and Walls	See Division 10.5 Landscaping, Fences, Walls and Screening					
	ZONE DISTRICTS	BUILDING FORMS	PRIMARY STREET	SIDE STREET	SIDE INTERIOR	REAR
Off-Street Parking Area	All E-SU, E-TU, E-RH, E-MU Zone Districts	Suburban House, Urban House, Duplex, and Tandem House	Any distance	Any distance	Any distance	Any distance
Intent: To allow off-street parking where it is <b>not less impactful due to the number of required parking spaces.</b>	<p>Side Setback Side Setback Side Setback ALLEY Side Setback Side Setback Side Setback</p> <p>Rear Setback Allowed Encroachment Allowed Encroachment Allowed Encroachment</p> <p>Primary Street Setback Allowed Encroachment Allowed Encroachment</p> <p>PRIMARY STREET SIDE STREET Not to Scale. Illustrative Only.</p>					

	ZONE DISTRICTS	BUILDING FORMS	PRIMARY STREET	SIDE STREET	SIDE INTERIOR	REAR
<p>Off-Street Parking Area</p> <p>When a Zone Lot contains two or more building forms with different permitted encroachments, the less restrictive standards shall apply for the entire Zone Lot.</p>	All E-RH and E-MU Zone Districts	Row House, Garden Court, and Apartment	Not allowed	Not allowed	Allowed within the rear 35% of the Zone Lot only	Any distance
		Town House	Not allowed	Not allowed* (*See exception below)	In the front 65% of the Zone Lot: 5' and at no point closer than 5' to the Zone Lot line. In the rear 35% of the Zone Lot: Any distance	Any distance
<p>Intent: To restrict off-street parking where it is <b>more impactful due to the number of required parking spaces.</b></p>	<p>The diagram shows a lot layout with a Primary Street on the bottom and a Side Street on the right. An Alley is located between the first and second building units. Building forms include Row House, House, Apartment, Town House, and House. Setback lines are shown for Side Interior, Rear, Primary Street, and Side Street. Encroachments are shown for the rear 35% of the lot. A hatched area at the bottom indicates an exception for the 5-foot back-out space.</p> <p>See Exception</p> <p>PRIMARY STREET</p> <p>Not to Scale. Illustrative Only.</p>					
<p>*Exception: The minimum 5' of back out space according to Section 10.4, Parking and Loading, shall be permitted to encroach 2.5' when:</p> <ul style="list-style-type: none"> <li>The encroachment is screened from the Side Street with a Garden Wall and 1 deciduous canopy tree or minimum 5' wide planting strip landscaped with 50% live plant material as described in Section 10.5.4.6, Landscaping Material Standards.</li> </ul>						



	ZONE DISTRICTS	BUILDING FORMS	PRIMARY STREET	SIDE STREET	SIDE INTERIOR	REAR
Off-Street Parking Area	All E-RX, E-MX, and E-MS Zone Districts	Town House	Not allowed	Not allowed* (*See exception below)	Any distance	Any distance
When a Zone Lot contains two or more building forms with different permitted encroachments, the less restrictive standards shall apply for the entire Zone Lot.		All others	Any Distance	Any distance	Any distance	Any distance
Intent: To restrict off-street parking where it is <b>more impactful due to the number of required parking spaces.</b>	<p>Not to Scale. Illustrative Only.</p>					
<p>*Exception: The minimum 5' of back out space according to Section 10.4, Parking and Loading, shall be permitted to encroach 2.5' when:</p> <ul style="list-style-type: none"> <li>The encroachment is screened from the Side Street with a Garden Wall and 1 deciduous canopy tree or minimum 5' wide planting strip landscaped with 50% live plant material as described in Section 10.5.4.6, Landscaping Material Standards.</li> </ul>						
	ZONE DISTRICTS	BUILDING FORMS	PRIMARY STREET	SIDE STREET	SIDE INTERIOR	REAR
Drive or Driveway	All E-SU, E-TU, E-RH and E-MU Zone Districts	Suburban House, Urban House, Duplex, and Tandem House	Any distance	Any distance	Any distance	Any distance
Intent: To allow a Drive or Driveway to access an Off-Street Parking Area.	<p>Not to Scale. Illustrative Only.</p>					
<p>Illustrative only</p>						

## DIVISION 4.4 USES ~~AND REQUIRED MINIMUM PARKING~~

### SECTION 4.4.1 APPLICABILITY

- 4.4.1.1 This Division 4.4 sets forth the land uses permitted; ~~and the~~ required zoning procedures ~~and the required minimum parking~~ for all the Urban Edge Neighborhood Context zone districts.
- 4.4.1.2 Uses not listed are prohibited, unless the Zoning Administrator specifically permits the unlisted use according to Section 12.4.6, Code Interpretations and Determination of Unlisted Uses.
- 4.4.1.3 For number of primary and accessory uses allowed per Zone Lot, see Section 1.2.3.5, Number of Structures and Uses Allowed per Zone Lot.

### SECTION 4.4.2 ORGANIZATION

#### 4.4.2.1 Organized by Primary, Accessory and Temporary Uses

The Use ~~and Parking~~ Table first presents all primary uses, then all accessory uses, and finally all temporary uses. Primary uses are arranged hierarchically within the table by use classification, category of primary uses, and then by specific use type. Accessory uses are organized by whether such use is accessory to a primary residential use or to a primary nonresidential use. Temporary uses are presented alphabetically ordered in the last division of the table.

#### 4.4.2.2 Primary Use Classifications, Categories & Specific Use Types

##### A. Primary Use Classifications

All primary land uses in the Use ~~and Parking~~ Table are organized into one of the following five general land use classifications:

1. Residential Uses
2. Civic, Public & Institutional Uses
3. Commercial Sales, Service & Repair Uses
4. Industrial, Manufacturing & Wholesale Uses
5. Agriculture

##### B. Primary Use Categories & Specific Use Types

Primary uses are further organized into use categories and specific use types listed under each general primary land use classification. The Use ~~and Parking~~ Table is organized into the above five general land use classifications, use categories and specific use types.

##### C. Classifications & Categories Are Mutually Exclusive

The general land use classifications and use categories listed in the Use ~~and Parking~~ Table are intended to be mutually exclusive; that is, a use classified into one use category, such as “lodging accommodations,” cannot be classified in a different use category, such as “congregate living,” unless otherwise expressly allowed by this Code.

## SECTION 4.4.3 EXPLANATION OF TABLE ABBREVIATIONS

### 4.4.3.1 General Explanation of Table Cell Entries

In each of the table cells, the entry will indicate first whether use limitations apply to the specific use, and then separated by a hyphen, the type of zoning review required prior to establishment of the use under this Code. For example, as described in more detail below, a cell entry “L-ZPIN” means, first, the use is subject to use limitations (the “L”), and, second, that the use is subject to zoning permit review with information notice (the “ZPIN”) prior to its establishment.

### 4.4.3.2 Permitted, Limited, Not Permitted

#### A. Permitted Use - No Use Limitations Apply (“P”)

A “P” in a table cell indicates that the use is permitted in the respective zone district, and is not subject to use limitations or standards.

#### B. Permitted Use - Subject to Use Limitations (“L”)

“L” in a table cell indicates the use is permitted in the zone district subject to compliance with the use limitations referenced in the last column of the use table (“Applicable Use Limitations”).

#### C. Uses Not Permitted (“NP”)

“NP” in a table cell indicates that the use is not permitted in the specific zone district.

### 4.4.3.3 Zoning Procedure

#### A. Use Subject to Zoning Permit Review (“ZP”)

“ZP” in a table cell indicates that the use is permitted in the respective zone district only if reviewed and approved according to the requirements in Section 12.4.1, Zoning Permit Review.

#### B. Use Subject to Zoning Permit Review with Informational Notice (“ZPIN”)

“ZPIN” in a table cell indicates that the use is permitted in the respective zone district only if reviewed and approved according to the public notice and procedural requirements in Section 12.4.2, Zoning Permit Review with Informational Notice. Such uses shall comply with any applicable use limitations noted in the last column of the use table (“Applicable Use Limitations”), as well as the review criteria stated in Section 12.4.2, Zoning Permit Review with Informational Notice.

#### C. Use Subject to Zoning Permit Review with Community Information Meeting (“ZPCIM”)

“ZPCIM” in a table cell indicates that the use is permitted in the respective zone district only if reviewed and approved according to the public notice and procedural requirements in Section 12.4.1, Zoning Permit Review. Prior to formal application, an applicant shall schedule a community information meeting and provide public notice of the community information meeting according to Section 12.3.4.6, Community Information Meeting.

#### D. Use Subject to Zoning Permit with Special Exception Review (“ZPSE”)

“ZPSE” in a table cell indicates that use is generally appropriate in the neighborhood context and zone district, yet may have the potential for limited impacts on adjacent properties or on the established character of the neighborhood context or zone district. “ZPSE” uses are subject to a Board of Adjustments public hearing according to Section 12.4.9, Zoning Permit with Special Exception Review, which grants the Board of Adjustment the authority to impose conditions on the specified use to mitigate any potential impacts. Such uses shall comply with any applicable use limitations noted in the last column of the use table (“Applicable Use Limitations”), as well as the review criteria stated in Section 12.4.9, Zoning Permit with Special Exception Review.

#### E. Uses Where More Than One Zoning Procedure Is Indicated

Where a table cell shows more than one zoning procedure applies to a use, for example “L-ZP/ZPIN”, the referenced use limitation (last table column) will indicate which zoning procedure applies in a specific case. For example, a table cell may indicate “L-ZPIN/ZPSE” for a use. This

means that the ZPIN zoning procedure will apply, unless the applicable use limitation specifies the ZPSE zoning procedure is triggered (e.g., by proximity to a Protected District).

#### 4.4.3.4 Enclosure of Uses

All primary, accessory and temporary uses must be established, operated and maintained within a Completely Enclosed Structure, unless otherwise specifically allowed by this Code. The Use ~~and~~ **Parking** Tables in Articles 3-9, Neighborhood Contexts and Special Contexts and Districts, indicate when a use may be established, operated or maintained outside a Completely Enclosed Structure by including an asterisk "\*" next to the specific use type. For example, the asterisk following the "Telecommunication Tower\*" use type in the tables indicates that a telecommunication tower land use need not be enclosed.

### SECTION 4.4.4 DISTRICT SPECIFIC STANDARDS

KEY: \* = Need Not be Enclosed P = Permitted Use without Limitations L = Permitted Use with Limitations NP = Not Permitted Use ZP = Zoning Permit Review ZPCIM = Subject to Zoning Permit Review with Community Information Meeting ZPIN = Subject to Zoning Permit Review with Informational Notice ZPSE = Subject to Zoning Permit with Special Exception Review When no ZP, ZPCIM, ZPIN, ZPSE listed = No Zoning Permit required

USE CATEGORY	SPECIFIC USE TYPE	E-SU-A	E-SU-B	E-SU-D	E-SU-Dx	E-SU-G	E-TU-B	E-TU-C	E-RH-2.5	E-MU-2.5	E-RX-3	E-RX-5	E-CC-3x	E-CC-3	E-MX-2x	E-MX-2A	E-MX-3A	E-MS-3	E-MS-5	APPLICABLE USE LIMITATIONS
<b>RESIDENTIAL PRIMARY USE CLASSIFICATION</b>																				
Household Living	Dwelling, Single Unit • <del>No Parking Requirements</del>	L-ZP	L-ZP	L-ZP	L-ZP	L-ZP	L-ZP	L-ZP	L-ZP	L-ZP	L-ZP	L-ZP	L-ZP	L-ZP	L-ZP	L-ZP	L-ZP	L-ZP	L-ZP	§11.2.7
	Dwelling, Two Unit • <del>Vehicle: 1/unit</del> • <del>Bicycle: No requirement</del>	L-ZP	L-ZP	L-ZP	L-ZP	L-ZP	L-ZP	L-ZP	L-ZP	L-ZP	L-ZP	L-ZP	L-ZP	L-ZP	L-ZP	L-ZP	L-ZP	L-ZP	L-ZP	§11.2.2; §11.2.7
	Dwelling, Multi-Unit • <del>Vehicle: 1/unit</del> • <del>Bicycle: 1/5 units (80/20)</del>	L-ZP	L-ZP	L-ZP	L-ZP	L-ZP	L-ZP	L-ZP	L-ZP	L-ZP	L-ZP	L-ZP	L-ZP	L-ZP	L-ZP	L-ZP	L-ZP	L-ZP	L-ZP	§11.2.3; §11.2.7
	Dwelling, Live / Work • <del>Vehicle: 1/unit</del> • <del>Bicycle: 1/5 units (80/20)</del>	NP	NP	NP	L-ZP	L-ZP	L-ZP	L-ZP	L-ZP	L-ZP	L-ZP	L-ZP	L-ZP	L-ZP	L-ZP	L-ZP	L-ZP	L-ZP	L-ZP	§11.2.4; §11.2.7
	Manufactured Home Community	NP	NP	NP	NP	NP	NP	NP	NP	NP	NP	NP	NP	NP	NP	NP	NP	NP	NP	NP
Residential Care	Residential Care, Type 1 • <del>Vehicle: .5/1,000 sf GFA</del> • <del>Bicycle: No requirement</del>	L/L-ZP	L/L-ZP	L/L-ZP	L/L-ZP	L/L-ZP	L/L-ZP	L/L-ZP	L/L-ZP	L/L-ZP	L/L-ZP	L/L-ZP	L/L-ZP	L/L-ZP	L/L-ZP	L/L-ZP	L/L-ZP	L/L-ZP	L/L-ZP	§11.2.8; §11.2.9
	Residential Care, Type 2 • <del>Vehicle: .5/1,000 sf GFA</del> • <del>Bicycle: No requirement</del>	L-ZPCIM	L-ZPCIM	L-ZPCIM	L-ZP	L-ZP	L-ZP	L-ZP	L-ZP	L-ZP	L-ZP	L-ZP	L-ZP	L-ZP	L-ZP	L-ZP	L-ZP	L-ZP	L-ZP	§11.2.8; §11.2.10
	Residential Care, Type 3 • <del>Vehicle: .5/1,000 sf GFA</del> • <del>Bicycle: No requirement</del>	NP	NP	NP	L-ZPCIM	L-ZPCIM	L-ZPCIM	NP	NP	L-ZPCIM	L-ZPCIM	NP	NP	L-ZPCIM	L-ZPCIM	NP	NP	L-ZPCIM	L-ZPCIM	§11.2.8; §11.2.11
	Residential Care, Type 4 • <del>Vehicle: .5/1,000 sf GFA</del> • <del>Bicycle: No requirement</del>	NP	NP	NP	NP	L-ZPCIM	L-ZPCIM	NP	NP	L-ZPCIM	L-ZPCIM	NP	NP	L-ZPCIM	L-ZPCIM	NP	NP	L-ZPCIM	L-ZPCIM	§11.2.8; §11.2.12
Congregate Living	All Types • <del>Vehicle: 1/1,000 sf GFA</del> • <del>Bicycle: 1/20,000 sf GFA</del>	NP	NP	E-RH-2.5: NP E-MU-2.5: P-ZP	P-ZP	P-ZP	P-ZP	P-ZP	P-ZP	P-ZP	P-ZP	P-ZP	P-ZP	P-ZP	P-ZP	P-ZP	P-ZP	P-ZP	P-ZP	

**Modernizing Parking Requirements**  
**LUTI Committee Review Draft**  
**May 13, 2025**

Article 4. Urban Edge Neighborhood Context  
 Division 4.4 Uses ~~and Required Minimum Parking~~

KEY: \* = Need Not be Enclosed P = Permitted Use without Limitations L = Permitted Use with Limitations NP = Not Permitted Use ZP = Zoning Permit Review ZPCIM = Subject to Zoning Permit Review with Community Information Meeting ZPIN = Subject to Zoning Permit Review with Informational Notice ZPSE = Subject to Zoning Permit with Special Exception Review When no ZP, ZPCIM, ZPIN, ZPSE listed = No Zoning Permit required

USE CATEGORY	SPECIFIC USE TYPE <ul style="list-style-type: none"> <li>• <del>Vehicle Parking Reqmt: # spaces per unit of measurement</del></li> <li>• <del>Bicycle Parking Reqmt Requirement: # spaces per unit of measurement (% Required Spaces in Enclosed Facility / % Required Spaces in Fixed Facility)</del></li> </ul>	E-SU-A E-SU-B E-SU-D E-SU-Dx E-SU-G										APPLICABLE USE LIMITATIONS	
		E-TU-B E-TU-C	E-RH-2.5	E-MU-2.5	E-RX-3 E-RX-5	E-CC-3x E-CC-3	E-MX-2x E-MS-2x	E-MX-2A E-MX-2	E-MX-3A E-MX-3	E-MS-3 E-MS-5			
<b>CIVIC, PUBLIC &amp; INSTITUTIONAL PRIMARY USE CLASSIFICATION</b>													
Basic Utilities	Utility, Major Impact* <ul style="list-style-type: none"> <li>• <del>Vehicle: .5/1,000 sf GFA</del></li> <li>• <del>Bicycle: No requirement</del></li> </ul>	L-ZPSE	L-ZPSE	L-ZPSE	L-ZPSE	L-ZPSE	L-ZPSE	L-ZPSE	L-ZPSE	L-ZPSE	L-ZPSE	L-ZPSE	§ 11.3.1
	Utility, Minor Impact* <ul style="list-style-type: none"> <li>• <del>Vehicle: .5/1,000 sf GFA</del></li> <li>• <del>Bicycle: No requirement</del></li> </ul>	L-ZP	L-ZP	L-ZP	L-ZP	L-ZP	L-ZP	L-ZP	L-ZP	L-ZP	L-ZP	L-ZP	§ 11.3.2
Community/ Public Services	Community Center* <ul style="list-style-type: none"> <li>• <del>Vehicle: .5/1,000 sf GFA</del></li> <li>• <del>Bicycle: 1/10,000 sf GFA (0/100)</del></li> </ul>	L-ZP	L-ZP	L-ZP	L-ZP	L-ZP	L-ZP	L-ZP	L-ZP	L-ZP	L-ZP	L-ZP	§ 11.3.3
	Day Care Center <ul style="list-style-type: none"> <li>• <del>Vehicle: 1/1,000 sf GFA</del></li> <li>• <del>Bicycle: 1/10,000 sf GFA (0/100)</del></li> </ul>	L-ZP	L-ZP	P-ZPIN	P-ZPIN	P-ZP	P-ZP	P-ZPIN	P-ZP	P-ZP	P-ZP	P-ZP	§ 11.3.4
	Postal Facility, Neighborhood <ul style="list-style-type: none"> <li>• <del>Vehicle: MS only: 2/1,000 sf GFA</del></li> <li>• <del>Vehicle: 2.5/1,000 sf GFA</del></li> <li>• <del>Bicycle: 1/20,000 sf GFA (60/40)</del></li> </ul>	NP	NP	NP	P-ZP	P-ZP	P-ZP	P-ZP	P-ZP	P-ZP	P-ZP	P-ZP	
	Postal Processing Center <ul style="list-style-type: none"> <li>• <del>Vehicle: 1/1,000 sf GFA</del></li> <li>• <del>Bicycle: 1/20,000 sf GFA (60/40)</del></li> </ul>	NP	NP	NP	P-ZP	P-ZP	P-ZP	NP	NP	P-ZP	P-ZP		
	Public Safety Facility <ul style="list-style-type: none"> <li>• <del>Vehicle: 1/1,000 sf GFA</del></li> <li>• <del>Bicycle: 1/10,000 sf GFA (0/100)</del></li> </ul>	L-ZP	L-ZP	L-ZP	L-ZP	P-ZP	P-ZP	P-ZP	P-ZP	P-ZP	P-ZP	P-ZP	§ 11.3.5
	Hospital	NP	NP	NP	NP	NP	NP	NP	NP	NP	NP	NP	
	Correctional Institution	NP	NP	NP	NP	NP	NP	NP	NP	NP	NP	NP	
Cultural/Special Purpose/Public Parks & Open Space	Cemetery*	NP	NP	NP	NP	NP	NP	NP	NP	NP	NP		
	Library <ul style="list-style-type: none"> <li>• <del>Vehicle: 1/1,000 sf GFA</del></li> <li>• <del>Bicycle: 1/10,000 sf GFA (0/100)</del></li> </ul>	P-ZP	P-ZP	P-ZP	P-ZP	P-ZP	P-ZP	P-ZP	P-ZP	P-ZP	P-ZP		
	Museum <ul style="list-style-type: none"> <li>• <del>Vehicle: 1/1,000 sf GFA</del></li> <li>• <del>Bicycle: 1/10,000 sf GFA (0/100)</del></li> </ul>	NP	NP	NP	NP	P-ZP	P-ZP	P-ZP	P-ZP	P-ZP	P-ZP		
	City Park* Open Space - Conservation* <ul style="list-style-type: none"> <li>• <del>No Parking Requirements</del></li> </ul>	P-ZP	P-ZP	P-ZP	P-ZP	P-ZP	P-ZP	P-ZP	P-ZP	P-ZP	P-ZP	P-ZP	
Education	Elementary or Secondary School <ul style="list-style-type: none"> <li>• <del>Vehicle - High School: 2/1,000 sf GFA</del></li> <li>• <del>Bicycle - High School: 1/20,000 sf GFA (0/100)</del></li> <li>• <del>Vehicle - All Others: 1/1,000 sf GFA</del></li> <li>• <del>Bicycle - All Others: 1/10,000 sf GFA (0/100)</del></li> </ul>	L-ZP	L-ZP	L-ZP	L-ZP	L-ZP	L-ZP	L-ZP	L-ZP	L-ZP	L-ZP	§ 11.3.8	

KEY: \* = Need Not be Enclosed P = Permitted Use without Limitations L = Permitted Use with Limitations NP = Not Permitted Use ZP = Zoning Permit Review ZPCIM = Subject to Zoning Permit Review with Community Information Meeting ZPIN = Subject to Zoning Permit Review with Informational Notice ZPSE = Subject to Zoning Permit with Special Exception Review When no ZP, ZPCIM, ZPIN, ZPSE listed = No Zoning Permit required

USE CATEGORY	SPECIFIC USE TYPE • <del>Vehicle Parking Reqmt: # spaces per unit of measurement</del> • <del>Bicycle Parking Reqmt Requirement: # spaces per unit of measurement (% Required Spaces in Enclosed Facility / % Required Spaces in Fixed Facility)</del>	E-SU-A E-SU-B E-SU-D E-SU-Dx E-SU-G										APPLICABLE USE LIMITATIONS	
		E-TU-B E-TU-C	E-RH-2.5 E-MU-2.5	E-RX-3 E-RX-5	E-CC-3x E-CC-3	E-MX-2x E-MS-2x	E-MX-2A E-MX-2	E-MX-3A E-MX-3	E-MS-3 E-MS-5				
Education	University or College • <del>Vehicle: 1/1,000 sf GFA</del> • <del>Bicycle: 1/10,000 sf GFA (0/100)</del>	NP	NP	NP	L-ZP	L-ZP	L-ZP	NP	L-ZP	L-ZP	L-ZP	\$11.3.8	
	Vocational or Professional School • <del>Vehicle: 1/1,000 sf GFA</del> • <del>Bicycle: 1/10,000 sf GFA (0/100)</del>	NP	NP	NP	L-ZP	L-ZP	L-ZP	L-ZP	L-ZP	L-ZP	L-ZP	\$11.3.8	
Public and Religious Assembly	All Types • <del>Vehicle: .5/1,000 sf GFA</del> • <del>Bicycle: 1/10,000 sf GFA (0/100)</del>	L-ZP	L-ZP	L-ZP	L-ZP	P-ZP	P-ZP	L-ZP	P-ZP	P-ZP	P-ZP	\$ 11.3.10	
COMMERCIAL SALES, SERVICES, & REPAIR PRIMARY USE CLASSIFICATION													
Adult Business	All Types	NP	NP	NP	NP	NP	NP	NP	NP	NP	NP	NP	See Section 9.4.4, Use Overlay Districts (UO-), for adult business use allowance in the UO-1 District.
Arts, Recreation & Entertainment	Arts, Recreation and Entertainment Services, Indoor • <del>Vehicle - Artist Studio: 0.3/1000 sf GFA</del> • <del>Vehicle - All Others - MS only: 2/1,000 sf GFA</del> • <del>Vehicle - All Others: 2.5/1,000 sf GFA</del> • <del>Bicycle: 1/20,000 sf GFA (20/80)</del>	NP	NP	NP	P-ZP	P-ZP	P-ZP	L-ZPIN	L-ZP	P-ZP	P-ZP	\$ 11.4.2	
	Arts, Recreation and Entertainment Services, Outdoor* • <del>Vehicle - MS only: 2/1,000 sf GFA</del> • <del>Vehicle: 2.5/1,000 sf GFA</del> • <del>Bicycle: 1/20,000 sf GFA (20/80)</del>	NP	NP	NP	NP	L-ZPSE	L-ZP	NP	L-ZPSE	L-ZPSE	L-ZPSE	\$ 11.4.3	
	Event Space with Alternate Parking and Loading* • <del>Vehicle: No requirement</del> • <del>Bicycle: No requirement</del>	NP	NP	NP	NP	NP	NP	NP	NP	NP	NP	NP	
	Sports and/or Entertainment Arena or Stadium*	NP	NP	NP	NP	NP	NP	NP	NP	NP	NP	NP	
Nonresidential Uses in Existing Business Structures In Residential Zones <del>(All Uses Shall Be Parked According to the Parking Requirement Stated in this Use Table for the Specific Nonresidential Use)</del>		L-ZP	L-ZP	L-ZP	Not Applicable						\$11.4.6		

KEY: \* = Need Not be Enclosed P = Permitted Use without Limitations L = Permitted Use with Limitations NP = Not Permitted Use ZP = Zoning Permit Review ZPCIM = Subject to Zoning Permit Review with Community Information Meeting ZPIN = Subject to Zoning Permit Review with Informational Notice ZPSE = Subject to Zoning Permit with Special Exception Review When no ZP, ZPCIM, ZPIN, ZPSE listed = No Zoning Permit required

USE CATEGORY	SPECIFIC USE TYPE <ul style="list-style-type: none"> <li>• <del>Vehicle Parking Reqmt: # spaces per unit of measurement</del></li> <li>• <del>Bicycle Parking Reqmt Requirement: # spaces per unit of measurement (% Required Spaces in Enclosed Facility / % Required Spaces in Fixed Facility)</del></li> </ul>											APPLICABLE USE LIMITATIONS											
		E-SU-A	E-SU-B	E-SU-D	E-SU-Dx	E-SU-G	E-TU-B	E-TU-C	E-RH-2.5	E-MU-2.5	E-RX-3		E-RX-5	E-CC-3x	E-CC-3	E-MX-2x	E-MX-2A	E-MX-2	E-MX-3A	E-MX-3	E-MS-3	E-MS-5	
Parking of Vehicles	Parking, Garage • <del>No Parking Requirements</del>	NP	NP	NP	P-ZP	P-ZP	P-ZP	NP	P-ZP	P-ZP	P-ZP	NP	P-ZP	P-ZP	P-ZP								
	Parking, Surface* • <del>No Parking Requirements</del>	NP	L-ZP	L-ZP	NP	P-ZP	P-ZP	NP	P-ZP	P-ZP	NP	NP	NP	NP	NP								§ 11.4.8
Eating & Drinking Establishments	All Types • <del>Vehicle - MS only: 2/1,000 sf GFA</del> • <del>Vehicle: 4.5/1,000 sf GFA</del> • <del>Bicycle: 1/5,000 sf GFA (0/100)</del>	NP	NP	NP	P-ZP	P-ZP	P-ZP	L-ZPSE	L-ZP	P-ZP	P-ZP	NP	P-ZP	P-ZP	P-ZP								§ 11.4.9
Lodging Accommodations	Bed and Breakfast Lodging • <del>Vehicle: 1/guest room or unit</del> • <del>Bicycle: 1/20,000 sf GFA (60/40)</del>	NP	NP	NP	P-ZP	P-ZP	P-ZP	NP	P-ZP	P-ZP	P-ZP	NP	P-ZP	P-ZP	P-ZP								
	Lodging Accommodations, All Others • <del>Vehicle: 1/guest room or unit</del> • <del>Bicycle: 1/20,000 sf GFA (60/40)</del>	NP	NP	NP	P-ZP	P-ZP	P-ZP	NP	NP	P-ZP	P-ZP	NP	NP	P-ZP	P-ZP								
Office	Dental / Medical Office or Clinic • <del>Vehicle: 2/1,000 sf GFA</del> • <del>Bicycle: 1/20,000 sf GFA (20/80)</del>	NP	NP	NP	L-ZP	L-ZP	L-ZP	L-ZP	L-ZP	L-ZP	L-ZP	NP	L-ZP	L-ZP	L-ZP								§ 11.4.10
	Office, All Others • <del>Vehicle: 2/1,000 sf GFA</del> • <del>Bicycle: 1/20,000 sf GFA (20/80)</del>	NP	NP	NP	P-ZP	P-ZP	P-ZP	P-ZP	P-ZP	P-ZP	P-ZP	NP	P-ZP	P-ZP	P-ZP								

KEY: \* = Need Not be Enclosed P = Permitted Use without Limitations L = Permitted Use with Limitations NP = Not Permitted Use ZP = Zoning Permit Review ZPCIM = Subject to Zoning Permit Review with Community Information Meeting ZPIN = Subject to Zoning Permit Review with Informational Notice ZPSE = Subject to Zoning Permit with Special Exception Review When no ZP, ZPCIM, ZPIN, ZPSE listed = No Zoning Permit required

USE CATEGORY	SPECIFIC USE TYPE • Vehicle Parking Reqmt: # spaces per unit of measurement • Bicycle Parking Reqmt Requirement: # spaces per unit of measurement (% Required Spaces in Enclosed Facility / % Required Spaces in Fixed Facility)	E-SU-A E-SU-B E-SU-D E-SU-Dx E-SU-G										APPLICABLE USE LIMITATIONS
		E-TU-B E-TU-C	E-RH-2.5 E-MU-2.5	E-RX-3 E-RX-5	E-CC-3x E-CC-3	E-MX-2x E-MS-2x	E-MX-2A E-MX-2	E-MX-3A E-MX-3	E-MS-3 E-MS-5			
Retail Sales, Service & Repair (Not Including Vehicle or Equipment Sales, Service & Repair)	Animal Sales and Services, Household Pets Only • Vehicle - MS only: 2/1,000 sf GFA • Vehicle: 2.5/1,000 sf GFA • Bicycle: 1/20,000 sf GFA (20/80)	NP	NP	NP	L-ZP	L-ZP	L-ZP	L-ZPIN	L-ZP	L-ZP	L-ZP	\$11.4.11; \$11.4.12
	Animal Sales and Services, All Others	NP	NP	NP	NP	NP	NP	NP	NP	NP	NP	
	Food Sales or Market • Vehicle - MS only: 2/1,000 sf GFA • Vehicle: 2.5/1,000 sf GFA • Bicycle: 1/20,000 sf GFA (20/80)	NP	NP	NP	L-ZP	P-ZP	P-ZP	L-ZP	L-ZP	P-ZP	P-ZP	\$11.4.11; \$11.4.14
	Pawn Shop	NP	NP	NP	NP	NP	NP	NP	NP	NP	NP	
	Retail Sales, Service & Repair -- Outdoor* • Vehicle - MS only: 2/1,000 sf GFA • Vehicle: 2.5/1,000 sf GFA • Bicycle: 1/20,000 sf GFA (20/80)	NP	NP	NP	NP	NP	L-ZP	L-ZPIN	L-ZPIN	L-ZPIN	NP	\$11.4.11; \$11.4.16
	Retail Sales, Service & Repair - Firearms Sales • Vehicle - MS only: 2/1,000 sf GFA • Vehicle: 2.5/1,000 sf GFA • Bicycle: 1/20,000 sf GFA (20/80)	NP	NP	NP	NP	NP	P-ZP	NP	NP	NP	P-ZP	
Retail Sales, Service & Repair, All Others • Vehicle - MS only: 2/1,000 sf GFA • Vehicle: 2.5/1,000 sf GFA • Bicycle: 1/20,000 sf GFA (20/80)	NP	NP	NP	P-ZP	P-ZP	P-ZP	L-ZP/L-ZPIN	L-ZP	P-ZP	P-ZP	\$11.4.11	



KEY: \* = Need Not be Enclosed P = Permitted Use without Limitations L = Permitted Use with Limitations NP = Not Permitted Use ZP = Zoning Permit Review ZPCIM = Subject to Zoning Permit Review with Community Information Meeting ZPIN = Subject to Zoning Permit Review with Informational Notice ZPSE = Subject to Zoning Permit with Special Exception Review When no ZP, ZPCIM, ZPIN, ZPSE listed = No Zoning Permit required

USE CATEGORY	SPECIFIC USE TYPE <ul style="list-style-type: none"> <li>• Vehicle Parking Reqmt: # spaces per unit of measurement</li> <li>• Bicycle Parking Reqmt Requirement: # spaces per unit of measurement (% Required Spaces in Enclosed Facility / % Required Spaces in Fixed Facility)</li> </ul>	E-SU-A E-SU-B E-SU-D E-SU-Dx E-SU-G										APPLICABLE USE LIMITATIONS
		E-TU-B E-TU-C	E-RH-2.5 E-MU-2.5	E-RX-3 E-RX-5	E-CC-3x E-CC-3	E-MX-2x E-MS-2x	E-MX-2A E-MX-2	E-MX-3A E-MX-3	E-MS-3 E-MS-5			
Vehicle / Equipment Sales, Rentals, Service & Repair	Automobile Emissions Inspection Facility <ul style="list-style-type: none"> <li>• Vehicle: .5/1,000 sf GFA</li> <li>• Bicycle: No requirement</li> </ul>	NP	NP	NP	NP	P-ZP	P-ZP	NP	L-ZP	P-ZP	P-ZP	§ 11.4.17
	Automobile Services, Light <ul style="list-style-type: none"> <li>• Vehicle: .5/1,000 sf GFA</li> <li>• Bicycle: No requirement</li> </ul>	NP	NP	NP	NP	L-ZP	L-ZP	NP	L-ZPSE	L-ZP	L-ZP	§11.4.18; §11.4.19
	Automobile Services, Heavy <ul style="list-style-type: none"> <li>• Vehicle: .5/1,000 sf GFA</li> <li>• Bicycle: No requirement</li> </ul>	NP	NP	NP	NP	NP	L-ZP/ ZPSE	NP	NP	NP	L-ZP/ ZPSE	§11.4.18; §11.4.20
	Automobile / Motorcycle / Light Truck Sales, Rentals, Leasing; Pawn Lot or Vehicle Auctioneer* <ul style="list-style-type: none"> <li>• Vehicle: .5/1,000 sf GFA</li> <li>• Bicycle: No requirement</li> </ul>	NP	NP	NP	L-ZP	NP	L-ZP	NP	NP	L-ZP	L-ZP	§ 11.4.21
	Heavy Vehicle/ Equipment Sales, Rentals & Service* <ul style="list-style-type: none"> <li>• Vehicle: .5/1,000 sf GFA</li> <li>• Bicycle: No requirement</li> </ul>	NP	NP	NP	NP	NP	P-ZPSE	NP	NP	NP	NP	
<b>INDUSTRIAL, MANUFACTURING &amp; WHOLESALE PRIMARY USE CLASSIFICATION</b>												
Communications and Information	Antennas Not Attached to a Tower* <ul style="list-style-type: none"> <li>• No Parking Requirements</li> </ul>	L-ZP	L-ZP	L-ZP	L-ZP	L-ZP	L-ZP	L-ZP	L-ZP	L-ZP	L-ZP	§ 11.5.2
	Communication Services <ul style="list-style-type: none"> <li>• Vehicle: .5/1,000 sf GFA</li> <li>• Bicycle: No requirement</li> </ul>	NP	NP	NP	L-ZP/ ZPSE	L-ZP/ ZPSE	L-ZP/ ZPSE	NP	L-ZP/ ZPSE	L-ZP/ ZPSE	E-MS-3: L-ZP/ ZPSE; E-MS-5 P-ZP	§ 11.5.1
	Telecommunications Towers* <ul style="list-style-type: none"> <li>• No Parking Requirements</li> </ul>	L-ZP/ZPIN/ ZPSE	L-ZP/ ZPIN/ ZPSE	L-ZP/ ZPIN/ ZPSE	L-ZP/ ZPIN/ ZPSE	L-ZP/ ZPIN/ ZPSE	L-ZP/ ZPIN/ ZPSE	L-ZP/ ZPIN/ ZPSE	L-ZP/ ZPIN/ ZPSE	L-ZP/ ZPIN/ ZPSE	L-ZP/ ZPIN/ ZPSE	§ 11.5.2
	Telecommunications Tower - Alternative Structure* <ul style="list-style-type: none"> <li>• No Parking Requirements</li> </ul>	L-ZP/ZPIN	L-ZP/ ZPIN	L-ZP/ ZPIN	L-ZP/ ZPIN	L-ZP/ ZPIN	L-ZP/ ZPIN	L-ZP/ ZPIN	L-ZP/ ZPIN	L-ZP/ ZPIN	L-ZP/ ZPIN	§ 11.5.2
	Telecommunication Facilities -- All Others* <ul style="list-style-type: none"> <li>• No Parking Requirements</li> </ul>	L-ZPIN	L-ZPIN	L-ZPIN	L-ZPIN	L-ZPIN	L-ZPIN	L-ZPIN	L-ZPIN	L-ZPIN	L-ZPIN	§ 11.5.2

KEY: \* = Need Not be Enclosed P = Permitted Use without Limitations L = Permitted Use with Limitations NP = Not Permitted Use ZP = Zoning Permit Review ZPCIM = Subject to Zoning Permit Review with Community Information Meeting ZPIN = Subject to Zoning Permit Review with Informational Notice ZPSE = Subject to Zoning Permit with Special Exception Review When no ZP, ZPCIM, ZPIN, ZPSE listed = No Zoning Permit required

USE CATEGORY	SPECIFIC USE TYPE • <del>Vehicle Parking Reqmt: # spaces per unit of measurement</del> • <del>Bicycle Parking Reqmt Requirement: # spaces per unit of measurement (% Required Spaces in Enclosed Facility / % Required Spaces in Fixed Facility)</del>	E-SU-A E-SU-B E-SU-D E-SU-Dx E-SU-G											APPLICABLE USE LIMITATIONS
		E-TU-B E-TU-C	E-RH-2.5 E-MU-2.5	E-RX-3 E-RX-5	E-CC-3x E-CC-3	E-MX-2x E-MS-2x	E-MX-2A E-MX-2	E-MX-3A E-MX-3	E-MS-3 E-MS-5				
Industrial Services	Contractors, Special Trade - General • <del>Vehicle: .5 / 1,000 sf GFA</del> • <del>Bicycle: No requirement</del>	NP	NP	NP	NP	NP	L-ZP	NP	NP	L-ZP	L-ZP	§ 11.5.3	
	Contractors, Special Trade - Heavy/ Contractor Yard*	NP	NP	NP	NP	NP	NP	NP	NP	NP	NP		
	Food Preparation and Sales, Commercial • <del>Vehicle: .5 / 1,000 sf GFA</del> • <del>Bicycle: No requirement</del>	NP	NP	NP	L-ZP	L-ZP	L-ZP	L-ZPIN	L-ZPIN	L-ZP	L-ZP	§ 11.5.5	
	Laboratory, Research, Development and Technological Services • <del>Vehicle: .5 / 1,000 sf GFA</del> • <del>Bicycle: No requirement</del>	NP	NP	NP	NP	NP	L-ZP	NP	NP	L-ZP	L-ZP	§ 11.5.6	
	Service/Repair, Commercial • <del>Vehicle: .5 / 1,000 sf GFA</del> • <del>Bicycle: No requirement</del>	NP	NP	NP	NP	NP	L-ZP	NP	NP	L-ZP	L-ZP	§ 11.5.7	
Manufacturing and Production	Manufacturing, Fabrication & Assembly -- Custom • <del>Vehicle: .5 / 1,000 sf GFA</del> • <del>Bicycle: No requirement</del>	NP	NP	NP	L-ZPIN	L-ZP	L-ZP	L-ZP	L-ZP	L-ZP	L-ZP	§ 11.5.8	
	Manufacturing, Fabrication & Assembly -- General • <del>Vehicle: .5 / 1,000 sf GFA</del> • <del>Bicycle: No requirement</del>	NP	NP	NP	NP	NP	L-ZP/ ZPSE	NP	NP	L-ZP/ ZPSE	L-ZP/ ZPSE	§ 11.5.9	
	Manufacturing, Fabrication & Assembly -- Heavy	NP	NP	NP	NP	NP	NP	NP	NP	NP	NP		
Mining & Extraction and Energy Producing Systems	Oil, Gas -- Production, Drilling*	NP	NP	NP	NP	NP	NP	NP	NP	NP	NP		
	Sand or Gravel Quarry*	NP	NP	NP	NP	NP	NP	NP	NP	NP	NP		
	Wind Energy Conversion Systems* • <del>No Parking Requirements</del>	L-ZPIN/ ZPSE	L-ZPIN/ ZPSE	L-ZPIN/ ZPSE	L-ZPIN/ ZPSE	L-ZPIN/ ZPSE	L-ZPIN/ ZPSE	L-ZPIN/ ZPSE	L-ZPIN/ ZPSE	L-ZPIN/ ZPSE	L-ZPIN/ ZPSE	§ 11.5.13	
Transportation Facilities	Airport*	NP	NP	NP	NP	NP	NP	NP	NP	NP	NP		
	Helipad, Helistop, Heliport* • <del>No Parking Requirements</del>	L-ZPIN	L-ZPIN	L-ZPIN	L-ZPIN	L-ZP	L-ZP	L-ZPIN	L-ZPIN	L-ZP	L-ZP	§ 11.5.14	
	Railroad Facilities*	NP	NP	NP	NP	NP	NP	NP	NP	NP	NP		
	Railway Right-of-Way* • <del>No Parking Requirements</del>	P-ZP	P-ZP	P-ZP	P-ZP	P-ZP	P-ZP	P-ZP	P-ZP	P-ZP	P-ZP		
	Terminal, Station or Service Facility for Passenger Transit System • <del>Vehicle: .5 / 1,000 sf GFA</del> • <del>Bicycle: No requirement</del>	L-ZP	L-ZP	L-ZP	L-ZP	P-ZP	P-ZP	P-ZP	P-ZP	P-ZP	P-ZP	§ 11.5.16	
	Terminal, Freight, Air Courier Services	NP	NP	NP	NP	NP	NP	NP	NP	NP	NP		
Waste Related Services	Automobile Parts Recycling Business*	NP	NP	NP	NP	NP	NP	NP	NP	NP	NP		
	Junkyard*	NP	NP	NP	NP	NP	NP	NP	NP	NP	NP		
	Recycling Center	NP	NP	NP	NP	NP	NP	NP	NP	NP	NP		
	Recycling Collection Station	NP	NP	NP	NP	NP	NP	NP	NP	NP	NP		
Waste Related Services	Recycling Plant, Scrap Processor	NP	NP	NP	NP	NP	NP	NP	NP	NP	NP		
	Solid Waste Facility	NP	NP	NP	NP	NP	NP	NP	NP	NP	NP		

**Modernizing Parking Requirements**  
**LUTI Committee Review Draft**  
**May 13, 2025**

Article 4. Urban Edge Neighborhood Context  
 Division 4.4 Uses ~~and Required Minimum Parking~~

KEY: \* = Need Not be Enclosed P = Permitted Use without Limitations L = Permitted Use with Limitations NP = Not Permitted Use ZP = Zoning Permit Review ZPCIM = Subject to Zoning Permit Review with Community Information Meeting ZPIN = Subject to Zoning Permit Review with Informational Notice ZPSE = Subject to Zoning Permit with Special Exception Review When no ZP, ZPCIM, ZPIN, ZPSE listed = No Zoning Permit required

USE CATEGORY	SPECIFIC USE TYPE <ul style="list-style-type: none"> <li>• <del>Vehicle Parking Reqmt: # spaces per unit of measurement</del></li> <li>• <del>Bicycle Parking Reqmt Requirement: # spaces per unit of measurement (% Required Spaces in Enclosed Facility / % Required Spaces in Fixed Facility)</del></li> </ul>	E-SU-A E-SU-B E-SU-D E-SU-Dx E-SU-G										APPLI-CABLE USE LIMITA-TIONS	
		E-TU-B E-TU-C	E-RH-2.5 E-MU-2.5	E-RX-3 E-RX-5	E-CC-3x E-CC-3	E-MX-2x E-MS-2x	E-MX-2A E-MX-2	E-MX-3A E-MX-3	E-MS-3 E-MS-5				
Wholesale, Storage, Warehouse & Distribution	Automobile Towing Service Storage Yard*	NP	NP	NP	NP	NP	NP	NP	NP	NP	NP	NP	
	Mini-storage Facility <ul style="list-style-type: none"> <li>• <del>Vehicle: 0.1/1,000 sf GFA</del></li> <li>• <del>Bicycle: No requirement</del></li> </ul>	NP	NP	NP	NP	P-ZP	P-ZP	NP	NP	L-ZP	NP	§ 11.5.23	
	Vehicle Storage, Commercial* <ul style="list-style-type: none"> <li>• <del>Vehicle: .5/1,000 sf GFA</del></li> <li>• <del>Bicycle: No requirement</del></li> </ul>	NP	NP	NP	NP	NP	L-ZPIN	NP	NP	NP	NP	§ 11.5.24	
	Wholesale Trade or Storage, General <ul style="list-style-type: none"> <li>• <del>Vehicle: .5/1,000 sf GFA</del></li> <li>• <del>Bicycle: No requirement</del></li> </ul>	NP	NP	NP	NP	NP	P-ZPIN	NP	NP	NP	NP		
	Wholesale Trade or Storage, Light <ul style="list-style-type: none"> <li>• <del>Vehicle: .5/1,000 sf GFA</del></li> <li>• <del>Bicycle: No requirement</del></li> </ul>	NP	NP	NP	NP	L-ZP/ ZPIN/ ZPSE	L-ZP/ ZPIN/ ZPSE	NP	NP	L-ZP/ ZPIN/ ZPSE	L-ZP/ ZPIN/ ZPSE	§ 11.5.26	
<b>AGRICULTURE PRIMARY USE CLASSIFICATION</b>													
Agriculture	Aquaculture*	NP	NP	NP	NP	NP	NP	NP	NP	NP	NP	NP	
	Garden, Urban*	L-ZP	L-ZP	L-ZP	L-ZP	L-ZP	L-ZP	L-ZP	L-ZP	L-ZP	L-ZP	L-ZP	§ 11.6.2
	Husbandry, Animal*	NP	NP	NP	NP	NP	NP	NP	NP	NP	NP	NP	
	Husbandry, Plant*	NP	NP	NP	NP	NP	NP	NP	NP	NP	NP	NP	
	Plant Nursery <ul style="list-style-type: none"> <li>• <del>Vehicle: .5/1,000 sf GFA</del></li> <li>• <del>Bicycle: No requirement</del></li> </ul>	NP	NP	NP	L-ZP	L-ZP	L-ZP	L-ZP	L-ZP	L-ZP	L-ZP	L-ZP	§ 11.6.5

KEY: \* = Need Not be Enclosed P = Permitted Use without Limitations L = Permitted Use with Limitations NP = Not Permitted Use ZP = Zoning Permit Review ZPCIM = Subject to Zoning Permit Review with Community Information Meeting ZPIN = Subject to Zoning Permit Review with Informational Notice ZPSE = Subject to Zoning Permit with Special Exception Review When no ZP, ZPCIM, ZPIN, ZPSE listed = No Zoning Permit required

USE CATEGORY	SPECIFIC USE TYPE											APPLICABLE USE LIMITATIONS	
	<ul style="list-style-type: none"> <li>Vehicle Parking Reqmt: # spaces per unit of measurement</li> <li>Bicycle Parking Reqmt Requirement: # spaces per unit of measurement (% Required Spaces in Enclosed Facility / % Required Spaces in Fixed Facility)</li> </ul>	E-SU-A											
		E-SU-B		E-RH-2.5				E-MX-2x	E-MX-2A				
		E-SU-D								E-MX-3A			
		E-SU-Dx	E-TU-B	E-MU-2.5	E-RX-3			E-MS-	E-MX-2			E-MS-3	
		E-SU-G	E-TU-C		E-RX-5	E-CC-3x	E-CC-3	2x	E-MS-2	E-MX-3		E-MS-5	

ACCESSORY TO PRIMARY RESIDENTIAL USES USE CLASSIFICATION

USE CATEGORY	SPECIFIC USE TYPE	L - Applicable to all Zone Districts										APPLICABLE USE LIMITATIONS	
		L-ZP	L-ZP	L-ZP	L-ZP	L-ZP	L-ZP	L-ZP	L-ZP	L-ZP	L-ZP		
Accessory to Primary Residential Uses  (Parking is Not Required for Accessory Uses Unless Specifically Stated in this Table or in an Applicable Use Limitation)	Unlisted Accessory Uses	L - Applicable to all Zone Districts										§ 11.7	
	Accessory Dwelling Unit	L-ZP	L-ZP	L-ZP	L-ZP	L-ZP	L-ZP	L-ZP	L-ZP	L-ZP	L-ZP	L-ZP	§ 11.7, § 11.8.2
	Domestic Employee	L	L	L	L	L	L	L	L	L	L	L	§11.7; §11.8.3
	Garden*	L	L	L	L	L	L	L	L	L	L	L	§ 11.7, § 11.8.4
	Keeping of Household Animals*	L/L-ZPIN	L/L-ZPIN	L/L-ZPIN	L/L-ZPIN	L/L-ZPIN	L/L-ZPIN	L/L-ZPIN	L/L-ZPIN	L/L-ZPIN	L/L-ZPIN	L/L-ZPIN	§ 11.7; § 11.8.5
	Keeping and Off-Street Parking of Vehicles, Motorcycles, Trailers & Recreational Vehicles*	L	L	L	L	L	L	L	L	L	L	L	§ 11.7; § 10.9
	Kennel or Exercise Run*	L	L	L	L	L	L	L	L	L	L	L	§ 11.7; § 11.8.6
	Limited Commercial Sales, Services Accessory to Multi-Unit Dwelling Use	NP	NP	NP	L-ZP	Not Applicable - See Permitted Primary Uses						§ 11.7; § 11.8.7	
	Outdoor Storage, Residential*	L	L	L	L	L	L	L	L	L	L	L	§11.7; §11.8.8
	Second Kitchen Accessory to Single Unit Dwelling Use	L-ZP	L-ZP	L-ZP	NP	L-ZP	L-ZP	L-ZP	L-ZP	L-ZP	NP	NP	§ 11.7; § 11.8.9
	Short-term Rental	L	L	L	L	L	L	L	L	L	L	L	§ 11.7; § 11.8.10
	Vehicle Storage, Repair and Maintenance*	L	L	L	L	L	L	L	L	L	L	L	§ 11.7; § 10.9
	Wind Energy Conversion Systems*	L-ZP/ZPSE	L-ZP/ZPSE	L-ZP/ZPSE	L-ZP/ZPSE	Not Applicable - See Permitted Primary Uses						§ 11.7, § 11.5.13	
Yard or Garage Sales*	L	L	L	L	L	L	L	L	L	L	L	§ 11.7; § 11.8.11	

HOME OCCUPATIONS ACCESSORY TO PRIMARY RESIDENTIAL USES USE CLASSIFICATION

USE CATEGORY	SPECIFIC USE TYPE	L-ZP	L-ZP	L-ZP	L-ZP	L-ZP	L-ZP	L-ZP	L-ZP	L-ZP	L-ZP	L-ZP	APPLICABLE USE LIMITATIONS
Home Occupations  (Parking is Not Required for Home Occupations Unless Specifically Stated in this Table or in an Applicable Use Limitations)	Child Care Home, Large	L-ZP	L-ZP	L-ZP	L-ZP	L-ZP	L-ZP	L-ZP	L-ZP	L-ZP	L-ZP	L-ZP	§ 11.9; §11.9.3
	All Other Types	L-ZP	L-ZP	L-ZP	L-ZP	L-ZP	L-ZP	L-ZP	L-ZP	L-ZP	L-ZP	L-ZP	§ 11.9; §11.9.4
	Unlisted Home Occupations	L-ZPIN - Applicable to all Zone Districts										§ 11.9; § 11.9.5	



KEY: \* = Need Not be Enclosed P = Permitted Use without Limitations L = Permitted Use with Limitations NP = Not Permitted Use ZP = Zoning Permit Review ZPCIM = Subject to Zoning Permit Review with Community Information Meeting ZPIN = Subject to Zoning Permit Review with Informational Notice ZPSE = Subject to Zoning Permit with Special Exception Review When no ZP, ZPCIM, ZPIN, ZPSE listed = No Zoning Permit required

USE CATEGORY	SPECIFIC USE TYPE • Vehicle Parking Reqmt: # spaces per unit of measurement • Bicycle Parking Reqmt Requirement: # spaces per unit of measurement (% Required Spaces in Enclosed Facility / % Required Spaces in Fixed Facility)	SPECIFIC USE TYPE										APPLICABLE USE LIMITATIONS	
		E-SU-A E-SU-B E-SU-D E-SU-Dx E-SU-G	E-TU-B E-TU-C	E-RH-2.5 E-MU-2.5	E-RX-3 E-RX-5	E-CC-3x E-CC-3	E-MX-2x E-MS-2x	E-MX-2A E-MX-2	E-MX-3A E-MX-3	E-MS-3 E-MS-5			
Accessory to Primary Nonresidential Uses  (Parking is Not Required for Accessory Uses Unless Specifically Stated in this Table or in an Applicable Use Limitation)	Occasional Sales, Services Accessory to Primary Places of Religious Assembly or Primary Uses Operated by Nonprofit Organizations*	L	L	L	L	L	L	L	L	L	L	L	\$11.7; §11.10.13
	Outdoor Gathering Area*	L/ L-ZP/ L-ZPIN	L/ L-ZP/ L-ZPIN	L/ L-ZP/ L-ZPIN	L/L-ZP/ L-ZPIN	L/L-ZP/ L-ZPIN	L/L-ZP/ L-ZPIN	L/L-ZP/ L-ZPIN	L/L-ZP/ L-ZPIN	L/L-ZP/ L-ZPIN	L/L-ZP/ L-ZPIN	L/L-ZP/ L-ZPIN	\$11.7; §11.10.14
	Outdoor Entertainment Accessory to an Eating/Drinking Establishment Use*	NP	NP	NP	L-ZPIN/ ZPSE	L-ZPIN/ ZPSE	L-ZPIN/ ZPSE	NP	NP	L-ZPIN/ ZPSE	L-ZPIN/ ZPSE	L-ZPIN/ ZPSE	\$11.7; §11.10.15
	Outdoor Retail Sale and Display*	NP	NP	NP	L-ZP/ ZPSE	L-ZP/ ZPSE	L-ZP/ ZPSE	NP	L-ZP/ ZPSE	L-ZP/ ZPSE	L-ZP/ ZPSE	L-ZP/ ZPSE	\$11.7; §11.10.16
	Outdoor Storage, General*	NP	NP	NP	NP	NP	NP	NP	NP	NP	NP	NP	\$11.7; §11.10.18
	Outdoor Storage, Limited*	NP	NP	NP	L-ZP	L-ZP	L-ZP	NP	NP	L-ZP	L-ZP	L-ZP	\$11.7; §11.10.18
	Rental or Sales of Adult Material Accessory to a Permitted Bookstore Retail Sales Use	NP	NP	NP	L	L	L	L	L	L	L	L	\$11.7; §11.10.20
Retail Food Establishment, Mobile (Food Truck)*	L-ZP	L-ZP	L-ZP	L-ZP	L-ZP	L-ZP	L-ZP	L-ZP	L-ZP	L-ZP	L-ZP	\$11.7; §11.10.19	

KEY: \* = Need Not be Enclosed P = Permitted Use without Limitations L = Permitted Use with Limitations NP = Not Permitted Use ZP = Zoning Permit Review ZPCIM = Subject to Zoning Permit Review with Community Information Meeting ZPIN = Subject to Zoning Permit Review with Informational Notice ZPSE = Subject to Zoning Permit with Special Exception Review When no ZP, ZPCIM, ZPIN, ZPSE listed = No Zoning Permit required

USE CATEGORY	SPECIFIC USE TYPE											APPLI-CABLE USE LIMITA-TIONS	
	• Vehicle Parking Reqmt: # spaces per unit of measurement • Bicycle Parking Reqmt Requirement: # spaces per unit of measurement (% Required Spaces in Enclosed Facility / % Required Spaces in Fixed Facility)	E-SU-A											
		E-SU-B		E-RH-2.5				E-MX-2x	E-MX-2A		E-MX-3A		
		E-SU-D											
		E-SU-Dx	E-TU-B	E-MU-2.5	E-RX-3			E-MS-2x	E-MX-2			E-MS-3	
		E-SU-G	E-TU-C		E-RX-5	E-CC-3x	E-CC-3		E-MS-2	E-MX-3		E-MS-5	

**TEMPORARY USE CLASSIFICATION**

	Unlisted Temporary Uses	L - Applicable to all Zone Districts										§ 11.11.1	
		NP	NP	NP	L-ZP	Not Applicable - See Permitted Primary Uses							§ 11.11.2
Temporary Uses (Parking is Not Required for Temporary Uses Unless Specifically Stated in this Table or in an Applicable Use Limitations)	Ambulance Service - Temporary	NP	NP	NP	L-ZP	Not Applicable - See Permitted Primary Uses							§ 11.11.2
	Amusement / Entertainment - Temporary*	NP	NP	NP	NP	NP	NP	NP	NP	NP	NP		
	Bazaar, Carnival, Circus or Special Event*	L-ZP	L-ZP	L-ZP	L-ZP	L-ZP	L-ZP	L-ZP	L-ZP	L-ZP	L-ZP	§ 11.11.4	
	Building or yard for construction materials*	L-ZP	L-ZP	L-ZP	L-ZP	L-ZP	L-ZP	L-ZP	L-ZP	L-ZP	L-ZP	§ 11.11.5	
	Concrete, Asphalt, and Rock Crushing Facility*	L-ZP	L-ZP	L-ZP	L-ZP	L-ZP	L-ZP	L-ZP	L-ZP	L-ZP	L-ZP	§ 11.11.6	
	Fence for Demolition or Construction Work	L-ZP	L-ZP	L-ZP	L-ZP	L-ZP	L-ZP	L-ZP	L-ZP	L-ZP	L-ZP	§ 11.11.7	
	Health Care Center	L-ZP	L-ZP	L-ZP	L-ZP	P-ZP	P-ZP	P-ZP	P-ZP	P-ZP	P-ZP	§ 11.11.8	
	Noncommercial Concrete Batching Plant*	L-ZP	L-ZP	L-ZP	L-ZP	L-ZP	L-ZP	L-ZP	L-ZP	L-ZP	L-ZP	§ 11.11.9	
	Outdoor Retail Sales - Pedestrian / Transit Mall*	NP	NP	NP	NP	NP	NP	NP	NP	NP	NP		
	Outdoor Retail Sales*	NP	NP	NP	L-ZP	L-ZP	L-ZP	L-ZP	L-ZP	L-ZP	NP	§ 11.11.11	
	Outdoor Sales, Seasonal*	NP	NP	NP	L-ZPIN	L-ZP	L-ZP	L-ZP/ZPIN	L-ZP/ZPIN	L-ZP	L-ZP	§ 11.11.12	
	Parking Lot Designated for a Special Event*	L-ZP	L-ZP	L-ZP	L-ZP	L-ZP	L-ZP	L-ZP	L-ZP	L-ZP	L-ZP	§ 11.11.13	
	Retail Food Establishment, Mobile (Food Truck)*	NP	NP	NP	L/L-ZP	L/L-ZP	L/L-ZP	L/L-ZP	L/L-ZP	L/L-ZP	L/L-ZP	§ 11.11.14	
	Temporary Construction Office	L-ZP	L-ZP	L-ZP	L-ZP	L-ZP	L-ZP	L-ZP	L-ZP	L-ZP	L-ZP	§ 11.11.15	
	Temporary Office - Real Estate Sales	L-ZP	L-ZP	L-ZP	L-ZP	L-ZP	L-ZP	L-ZP	L-ZP	L-ZP	L-ZP	§ 11.11.16	
Temporary Managed Community*	L-ZPCIM	L-ZPCIM	L-ZPCIM	L-ZPCIM	L-ZPCIM	L-ZPCIM	L-ZPCIM	L-ZPCIM	L-ZPCIM	L-ZPCIM	§ 11.11.17		
Tent for Religious Services	NP	NP	NP	NP	NP	NP	NP	NP	NP	NP			

## SECTION 5.3.3 BUILDING FORM STANDARDS FOR PRIMARY STRUCTURES

### 5.3.3.1 Applicability

All development, except detached accessory structures, in all the Urban Neighborhood Context zone districts.

### 5.3.3.2 District Specific Standards

The table below states the building forms allowed in each zone district. The table also summarizes the maximum number of structures allowed per Zone Lot, which is stated in more detail in Section 1.2.3.5, Number of Uses and Structures Allowed per Zone Lot.

See also Division 1.4, Building Form Standards - General Provisions, for additional standards related to initial assignment of building form standards to new and existing structures and for rules governing combining or changing building forms. Building Connectors between two detached structures shall follow the standards provided in Section 1.4.5, Applicable Building Form Standards for Detached Structures with Building Connector.

Urban (U-) Neighborhood Context Zone Districts		Building Forms											
		Suburban House	Urban House	Duplex	Tandem House	Row House	Garden Court	Town House	Apartment	Drive Thru Services	Drive Thru Restaurant	General	Shopfront
<b>Max Number of Primary Structures per Zone Lot*</b>		1	1	1	2	No Maximum							
<b>RESIDENTIAL ZONE DISTRICTS</b>													
Single Unit (SU)	U-SU-A, -B, -C, -E, -H		■		●								
	U-SU-A2, -B2, -C2		■	□	□								
Two Unit (TU)	U-TU-B, -C		■	■	■								
	U-TU-B2		■	■	■	□							
Row House (RH)	U-RH-2.5		■	■	■	■							
	U-RH-3A		■	■	■	■		□					
<b>COMMERCIAL MIXED USE ZONE DISTRICTS</b>													
Residential Mixed Use (RX)	U-RX-3, -5							■				■	
Mixed Use (MX)	U-MX-2x							■				■ ■	
	U-MX-2, -3							■	□	□		■ ■	
Main Street (MS)	U-MS-2x							■				■	
	U-MS-2, -3, -5							■	□	□		■	

\*See Section 1.2.3.5, Number of Uses and Structures Allowed Per Zone Lot, for exceptions.

■ = Allowed

● = Tandem House building form allowed subject to exception stated in Section 1.2.3.5.B, Allowed Increases on Zone Lot with Certain Existing Accessory Structures in SU- and TU- Zone Districts.

□ = Allowed subject to geographic limitations found in the applicable building form table.



### 5.3.3.3 District Specific Standards

#### A. Urban House

Not to Scale. Illustrative Only.

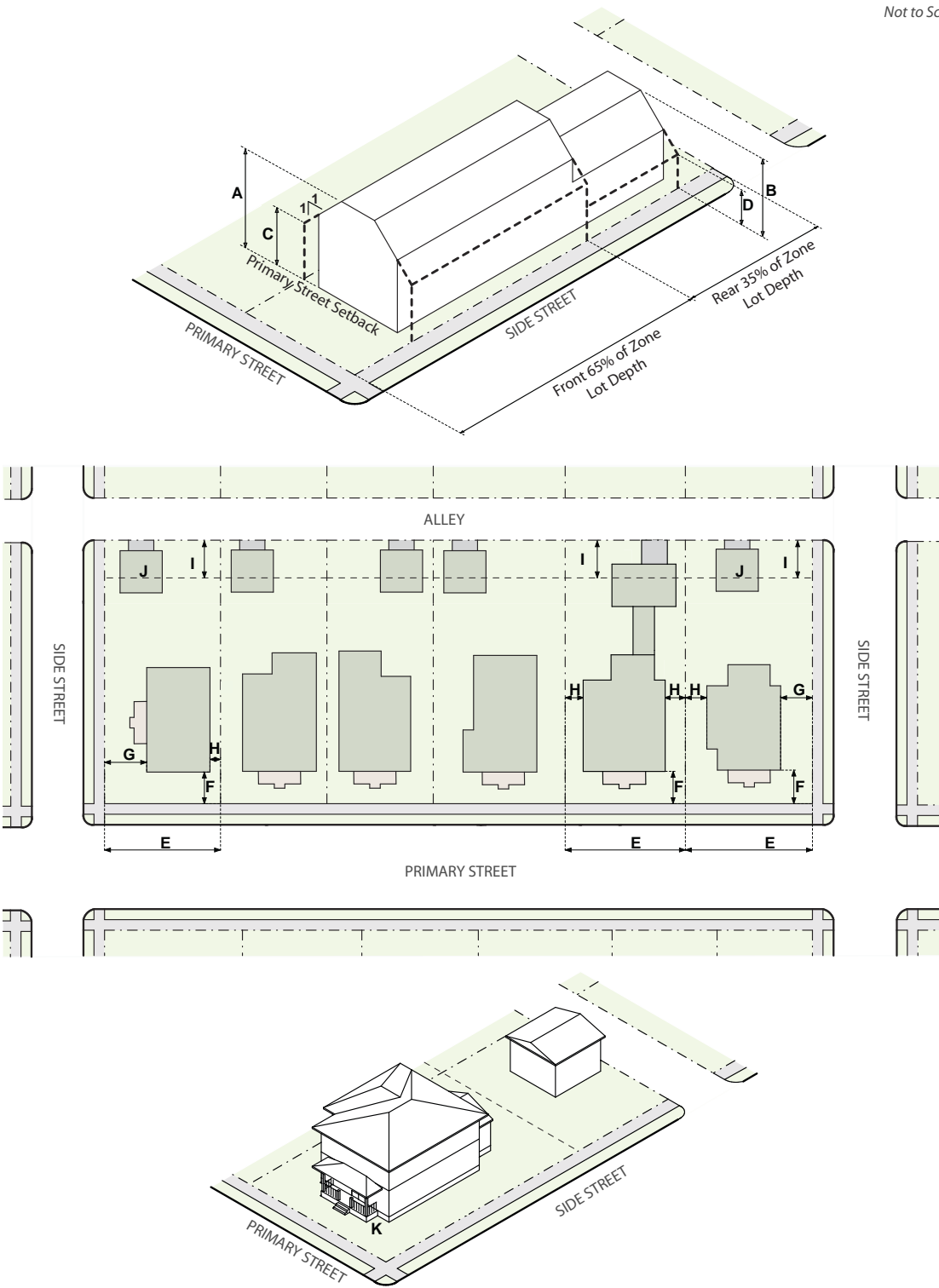

# URBAN HOUSE

		U-SU-A, A2 U-TU-B, B2	U-SU-B, B2 U-TU-C	U-SU-C, C2	U-SU-E	U-SU-H	U-RH-2.5 U-RH-3A
<b>HEIGHT</b>							
	Stories, front 65% / rear 35% of zone lot depth (max)	2.5/1	2.5/1	2.5/1	2.5/1	3/1	2.5/1
A/B	Feet, front 65% / rear 35% of zone lot depth (max)	30'/17'	30'/17'	30'/17'	30'/17'	30'/17'	30'/17'
	Feet, front 65% of zone lot depth, permitted height increase	1' for every 5' increase in Zone Lot width over 50' up to a maximum height of 35'					
	Feet, rear 35% of zone lot depth, permitted height increase	1' for every 3' increase in side setback up to a maximum height of 19'					
C/D	Bulk Plane Vertical Height at Side Interior and Side Street zone lot line in front 65% / rear 35% of Zone Lot Depth	17'/10'	17'/10'	17'/10'	17'/10'	17'/10'	17'/10'
	Bulk Plane Slope from Side Interior and Side Street zone lot line	45°	45°	45°	45°	45°	45°
		U-SU-A, A2 U-TU-B, B2	U-SU-B, B2 U-TU-C	U-SU-C, C2	U-SU-E	U-SU-H	U-RH-2.5 U-RH-3A
<b>SITING</b>							
<b>ZONE LOT</b>							
	Zone Lot Area (min)	3,000 sf	4,500 sf	5,500 sf	7,000 sf	10,000 sf	3,000 sf
E	Zone Lot Width (min)	25'	35'	50'	50'	75'	25'
		All U-SU, TU, RH					
<b>SETBACKS AND BUILDING COVERAGE BY ZONE LOT WIDTH</b>		30' or Less	Greater than 30' and up to 40'		Greater than 40' and less than 75'		75' or Greater
F	Primary Street (min)	Calculated per Sec. 13.1.5.9					
G	Side Street (min)	3'	5'		5'		7.5'
H	Side Interior (min)	3'	3' min one side/ 10' min combined		5'		10'
I	Rear, where Alley (public or private) abuts a Rear Zone Lot Line (min)	12'	12'		12'		12'
	Rear, where Alley (public or private) does not abut a Rear Zone Lot Line (min)	20'	20'		20'		20'
	Building Coverage per Zone Lot, including all accessory structures (max)	60%	45%		45%		40%
<b>PARKING BY ZONE LOT WIDTH</b>							
	Parking and Drive Lot Coverage in Primary Street Setback (max)	Maximum 16-foot wide measured parallel to the Primary Street zone lot line for any length, or 33% of the zone lot area within the Primary Street setback, whichever is greater					
	Vehicle Access	From Alley; or Street access allowed when no Alley present. See Sec. 5.3.7.4 for exceptions.					
J	<b>DETACHED ACCESSORY STRUCTURES</b>	See Sec. 5.3.4					
		U-SU-A, A2 U-TU-B, B2	U-SU-B, B2 U-TU-C	U-SU-C, C2	U-SU-E	U-SU-H	U-RH-2.5 U-RH-3A
<b>DESIGN ELEMENTS</b>							
<b>BUILDING CONFIGURATION</b>							
	Attached Garage Allowed	(1) Shall not be located closer to the minimum Primary Street Zone Lot Line than the Primary Street-facing Façade(s) comprising at least 65% of the total width of the primary structure enclosing the primary use. (2) May follow the General Detached Structure building form Side Street, Side Interior and Rear setbacks provided no permitted height increase has been applied to the Attached Garage					
	Primary Street Facing Attached Garage Door Width in front 50% of zone lot depth (max)	35% of the entire width of the Primary Street-facing Façade of the primary structure or 16', whichever is greater					
	Rooftop or Second Story Decks	See Section 5.3.5.2					
	Upper Story Stepback, for any portion of building with Low-slope Roof, above 25': Primary Street (min)	10'	10'	10'	10'	10'	10'
<b>STREET LEVEL ACTIVATION</b>							
K	Pedestrian Access, Primary Street	Entry Feature					
<b>USES</b>		All U-SU, TU, RH					
		Primary Uses shall be limited to Single Unit Dwelling and permitted Congregate Living, Residential Care and Nonresidential uses. See Division 5.4, Uses, and Required Minimum Parking					

See Sections 5.3.5 - 5.3.7 for Supplemental Design Standards, Design Standard Alternatives, and Design Standard Exceptions.

## DUPLEX

					U-TU-B	U-RH-2.5	
<b>HEIGHT</b>		U-SU-A2*	U-SU-B2*	U-SU-C2*	U-TU-B2	U-TU-C	U-RH-3A
	Stories, front 65% / rear 35% of zone lot depth (max)	2.5/1	2.5/1	2.5/1	2.5/1	2.5/1	2.5/1
A/B	Feet, front 65% / rear 35% of zone lot depth (max)	30'/17'	30'/17'	30'/17'	30'/17'	30'/17'	30'/17'
	Feet, front 65% of zone lot depth, permitted height increase	1' for every 5' increase in Zone Lot width over 50' up to a maximum height of 35'					
	Feet, rear 35% of zone lot depth, permitted height increase	1' for every 3' increase in side setback up to a maximum height of 19'					
C/D	Bulk Plane Vertical Height at Side interior and Side street zone lot line in front 65% / rear 35% of zone lot depth	17'/10'	17'/10'	17'/10'	17'/10'	17'/10'	17'/10'
	Bulk Plane Slope from Side interior and Side Street zone lot line	45°	45°	45°	45°	45°	45°

					U-TU-B	U-RH-2.5	
<b>SITING</b>		U-SU-A2*	U-SU-B2*	U-SU-C2*	U-TU-B2	U-TU-C	U-RH-3A
<b>ZONE LOT</b>							
	Zone Lot Area (min)	3,000 sf	4,500 sf	5,500 sf	4,500 sf	5,500 sf	4,500 sf
E	Zone Lot Width (min)	25'	35'	50'	35'	50'	35'

		U-SU-A2*, -B2*, -C2*; All U-TU, RH Districts					
<b>SETBACKS AND BUILDING COVERAGE BY ZONE LOT WIDTH</b>		30' or Less	Greater than 30' and up to 40'	Greater than 40' and less than 75'	75' or Greater		
F	Primary Street (min)	Calculated per Sec. 13.1.5.9					
G	Side Street (min)	3'	5'	5'	5'		
H	Side Interior (min)	3'	3' min one side/ 10' min combined	5'	10'		
I	Rear, where Alley (public or private) abuts a Rear Zone Lot Line (min)	12'	12'	12'	12'		
I	Rear, where Alley (public or private) does not abut a Rear Zone Lot Line (min)	20'	20'	20'	20'		
	Building Coverage per Zone Lot, including all accessory structures (max)	60%	45%	45%	40%		
<b>PARKING BY ZONE LOT WIDTH</b>							
	Parking and Drive Lot Coverage in Primary Street Setback (max)	50%	50%	50%	50%		
	Vehicle Access	From Alley; or Street access allowed when no Alley present. See Sec. 5.3.7.4 for exceptions.					
J	<b>DETACHED ACCESSORY STRUCTURES</b>	See Sec. 5.3.4					

					U-TU-B	U-RH-2.5	
<b>DESIGN ELEMENTS</b>		U-SU-A2*	U-SU-B2*	U-SU-C2*	U-TU-B2	U-TU-C	U-RH-3A
<b>BUILDING CONFIGURATION</b>							
	Attached Garage Allowed	(1) Shall not be located closer to the minimum Primary Street Zone Lot Line than the Primary Street-facing Façade(s) comprising at least 65% of the total width of the primary structure enclosing the primary use. (2) May follow the General Detached Structure building form standards Side Street, Side Interior and Rear setbacks provided no permitted height increase has been applied to the Attached Garage					
	Primary Street Facing Attached Garage Door Width in front 50% of zone lot depth (max)	35% of the entire width of the Primary Street-facing Façade of the dwelling primary structure or 16', whichever is greater					
	Rooftop or Second Story Decks	See Section 5.3.5.2					
	Upper Story Stepback, for any portion of building with Low-slope Roof, above 25': Primary Street (min)	10'	10'	10'	10'	10'	10'

K	<b>STREET LEVEL ACTIVATION</b>	Pedestrian Access, Primary Street					
		Entry Feature					

<b>USES</b>		U-SU-A2*, -B2*, -C2*; All U-TU, RH Districts					
		Primary Uses shall be limited to Two Unit Dwelling and permitted Congregate Living, Residential Care and Nonresidential uses. See Div. 5.4, Uses, and Required Minimum Parking					

See Sections 5.3.5 - 5.3.7 for Supplemental Design Standards, Design Standard Alternatives and Design Standard Exceptions

\*Form is permitted ONLY on corner zone lots where at least one of the intersecting streets is a collector or arterial street, according to the functional street classifications adopted by the Department of Transportation and Infrastructure ("DOTI").

# TANDEM HOUSE

<b>HEIGHT</b>		U-SU-A2*	U-SU-B2*	U-SU-C2*	U-TU-B U-TU-B2	U-TU-C	U-RH-2.5 U-RH-3A
	Stories (max)	2.5	2.5	2.5	2.5	2.5	2.5
A/B	Feet, front 65% / rear 35% of zone lot depth (max)	30'/24'	30'/24'	30'/24'	30'/24'	30'/24'	30'/24'
	Feet, front 65% of zone lot depth, permitted height increase	1' for every 5' increase in Zone Lot width over 50' up to a maximum height of 35'					
C/D	Bulk Plane Vertical Height at Side interior and Side street zone lot line in front 65% / rear 35% of zone lot depth	17'/10'	17'/10'	17'/10'	17'/10'	17'/10'	17'/10'
	Bulk Plane Slope from Side interior and Side Street zone lot line	45°	45°	45°	45°	45°	45°
<b>SITING</b>		U-SU-A2*	U-SU-B2*	U-SU-C2*	U-TU-B U-TU-B2	U-TU-C	U-RH-2.5 U-RH-3A
<b>ZONE LOT</b>							
	Zone Lot Area (min)	3,000 sf	4,500 sf	5,500 sf	4,500 sf	5,500 sf	4,500 sf
E	Zone Lot Width (min)	25'	35'	50'	35'	50'	35'
	Number of Primary Structures per Zone Lot (max)	2	2	2	2	2	2
<b>All U-SU, TU, RH Districts</b>							
<b>Greater than 30' and up to 40'</b>							
<b>Greater than 40' and less than 75'</b>							
<b>75' or Greater</b>							
<b>SETBACKS AND BUILDING COVERAGE BY ZONE LOT WIDTH</b>							
F	Primary Street (min)	Calculated per Sec. 13.1.5.9					
G	Side Street (min)	3'	5'	5'	5'	5'	5'
H	Side Interior, for Primary Structure #1 (min one side/min combined)	3'/6'	5'/10'	5'/10'	5'/10'	5'/15'	5'/15'
I	Side Interior, for Primary Structure #2 (min one side/min combined)**	3'/6'	5'/10'	5'/10'	5'/10'	5'/15'	5'/15'
J	Rear, for Primary Structure #1, as a % of zone lot depth (min)	50%	50%	50%	50%	50%	50%
K	Rear, for Primary Structure #2 (min)	5'	5'	5'	5'	5'	5'
	Building Coverage per Zone Lot, including all accessory structures (max)	60%	45%	45%	45%	40%	40%
<b>BUILDING SEPARATION</b>							
L	Horizontal distance between closest above-grade portions of each Primary Structure (min)	6'	6'	6'	6'	6'	6'
<b>PARKING BY ZONE LOT WIDTH</b>							
	Parking and Drive Lot Coverage in Primary Street Setback (max)	50%	50%	50%	50%	50%	50%
	Vehicle Access	From Alley; or Street access allowed when no Alley present (See Section 5.3.7.4, Vehicle Access From Alley Required - Exceptions)					
<b>DETACHED ACCESSORY STRUCTURES</b>							
See Sec. 5.3.4							
<b>DESIGN ELEMENTS</b>		U-SU-A2*	U-SU-B2*	U-SU-C2*	U-TU-B U-TU-B2	U-TU-C	U-RH-2.5 U-RH-3A
<b>BUILDING CONFIGURATION</b>							
	Attached Garage Allowed	(1) Shall not be located closer to the minimum Primary Street Zone Lot Line than the Primary Street-facing Façade(s) comprising at least 65% of the total width of the primary structure enclosing the primary use. (2) May follow the General Detached Structure building form Side Street, Side Interior and Rear setbacks provided no permitted height increase has been applied to the Attached Garage					
	Primary Street Facing Attached Garage Door Width in front 50% of zone lot depth (max)	35% of the entire width of the Primary Street-facing Façade of the primary structure or 16', whichever is greater					
	Rooftop or Second Story Decks	See Section 5.3.5.2					
	Upper Story Stepback, for any portion of building with Low-slope Roof, above 25': Primary Street (min), for Structure #1 and for Structure #2 in front 50% of zone lot depth	10'	10'	10'	10'	10'	10'
<b>STREET LEVEL ACTIVATION</b>							
M	Pedestrian Access, Primary Street	Primary Structure #1: Entry Feature Primary Structure #2: No Requirement					
<b>USES</b>		U-SU-A2*, -B2*, -C2*; All U-TU, RH Districts					
Primary Uses shall be limited to Single Unit Dwelling per primary structure. See Div. 5.4 Uses, and Required Minimum Parking							

See Sections 5.3.5 - 5.3.7 for Supplemental Design Standards, Design Standard Alternatives and Design Standard Exceptions.

\*\*Form is permitted on corner zone lots where at least one of the intersecting streets is a collector or arterial street, according to the functional street classifications adopted by the Department of Transportation and Infrastructure ("DOTI"). Form is also permitted if zone lot and existing structures qualify under the exception allowed in Section 1.2.3.5.B, Allowed Increases on Zone Lot with Certain Existing Accessory Structures in SU- and TU- Zone Districts.

## ROW HOUSE

<b>HEIGHT</b>		<b>U-TU-B2*</b>	<b>U-RH-2.5</b>	<b>U-RH-3A</b>
<b>A</b>	Stories, front 65% / rear 35% of zone lot depth (max)	2.5/2.5	2.5/1	2.5/1
<b>A</b>	Feet, front 65% / rear 35% of zone lot depth (max)	35'/35'	35'/19'	35'/19'
<b>B</b>	Side Wall Height, for Pitched Roof, within 15' of Side Interior and Side Street (max)	25'	25'	25'
<b>C</b>	Upper Story Setback, for Low-slope Roof, Above 25': Side, Interior and Side Street (min)	15'	15'	15'
<b>SITING</b>		<b>U-TU-B2*</b>	<b>U-RH-2.5</b>	<b>U-RH-3A</b>
<b>ZONE LOT</b>				
	Zone Lot Area (min/max)	6,000 sf / 9,375 sf	6,000 sf / na	6,000 sf / na
<b>D</b>	Zone Lot Width (min)	50'	50'	50'
	Dwelling Units per Primary Residential Structure (max)	na	10	10
<b>SETBACKS</b>				
<b>E</b>	Primary Street (min)	Calculated per Sec. 13.1.5.9		
<b>E</b>	Side Street (min)	5'	5'	5'
<b>F</b>	Side Interior (min)	5'	5'	5'
	Rear, where Alley (public or private) abuts a Rear Zone Lot Line (min)	12'	12'	12'
	Rear, where Alley (public or private) does not abut a Rear Zone Lot Line (min)	20'	20'	20'
<b>PARKING</b>				
	Surface Parking between building and Primary Street/Side Street	Not Allowed/Allowed		
	Vehicle Access	From Alley; or From street when no Alley present		
<b>G</b>	<b>DETACHED ACCESSORY STRUCTURES</b>	See Sec. 5.3.4		
<b>DESIGN ELEMENTS</b>		<b>U-TU-B2*</b>	<b>U-RH-2.5</b>	<b>U-RH-3A</b>
<b>BUILDING CONFIGURATION</b>				
<b>H</b>	Dwelling Units Oriented to the Street	All Dwelling Units shall be Oriented to the Street		
	Dwelling Unit Configuration	Structure shall only contain Side-by-Side Dwelling Units		
<b>I</b>	Upper Story Stepback, for any portion of building with Low-slope Roof, Above 25': Primary Street (min)	10'	10'	10'
	Street facing attached garage door width per Primary Structure (max)	20'	20'	20'
	Attached Garage Allowed	May follow the General Detached Structure building form Side Street, Side Interior and Rear setbacks		
	Rooftop or Second Story Decks	See Section 5.3.5.2		
<b>STREET LEVEL ACTIVATION</b>				
<b>J</b>	Pedestrian Access	Each unit shall have a street-facing Entrance		
<b>USES</b>		U-TU-B2*, U-RH-2.5 and U-RH-3A		
		Primary Uses shall be limited to Multi Unit Dwelling (3+). See Div. 5.4, Uses, <b>and Required Minimum Parking</b>		

See Sections 5.3.5 - 5.3.7 for Supplemental Design Standards, Design Standard Alternatives and Design Standard Exceptions

\*Form is permitted ONLY on corner zone lots where at least one of the intersecting streets is a collector or arterial street, according to the functional street classifications adopted by the Department of Transportation and Infrastructure ("DOTI").

## TOWN HOUSE

		U-MX-2				U-MS-2		
<b>HEIGHT</b>		U-RX-3	U-RX-5	U-MX-2x	U-MX-3	U-MS-2x	U-MS-3	U-MS-5
A	Stories (max)	3	5	2	3	2	3	5
A	Feet (min/max)	na/38'	na/70'	na/30'	na/38'	na/30'	na/38'	24/70'
<b>SITING</b>		U-RX-3	U-RX-5	U-MX-2x	U-MX-3	U-MS-2x	U-MS-3	U-MS-5
<b>REQUIRED BUILD-TO</b>								
B	Primary Street (min build-to % within min/max range)	70%	70%	70%	70%	75%	75%	75%
		10'/15'	10'/15'	10'/15'	10'/15'	10'/15'	10'/15'	10'/15'
	Side Street (min build-to % within min/max range)	na	na	na	na	25%	25%	25%
						7.5'/15'	7.5'/15'	7.5'/15'
<b>SETBACKS</b>								
C	Primary Street (min)	10'	10'	10'	10'	10'	10'	10'
D	Side Street (min)	7.5'	7.5'	7.5'	7.5'	7.5'	7.5'	7.5'
E	Side Interior (min)	5'	5'	5'	5'	5'	5'	5'
F	Side Interior, adjacent to Protected District (min)			U-MX-2x and U-MS-2x: 5'				
				All other Zone Districts: 10'				
	Rear (min)	0'	0'	0'	0'	0'	0'	0'
	Rear, adjacent to Protected District, where an Alley (public or private) abuts a Rear Zone Lot Line (min)			U-MX-2x and U-MS-2x: 12'				
				All other Zone Districts: 0'				
	Rear, adjacent to Protected District, where Alley (public or private) does not abut a Rear Zone Lot Line			U-MX-2x and U-MS-2x: 20'				
				All other Zone Districts: 10'				
<b>PARKING</b>								
	Surface Parking between building and Primary Street/Side Street	RX and MX: Not Allowed/Allowed				MS: Not Allowed/Not Allowed		
	Vehicle Access	From Alley; or Street access allowed when no Alley present						
<b>DESIGN ELEMENTS</b>		U-RX-3	U-RX-5	U-MX-2x	U-MX-3	U-MS-2x	U-MS-3	U-MS-5
<b>BUILDING CONFIGURATION</b>								
G	Dwelling Units Oriented to the Street	Required if any portion of the Dwelling Unit is located within 20' of Primary Street Zone Lot Line or 20' of the Side Street Zone Lot Line.						
	Dwelling Unit Configuration	Structure may contain Side-by-Side Dwelling Units						
	Upper Story Setback Above 27' adjacent to Protected District: Rear, alley/Rear, no alley and Side Interior (min)	15'/25'	20'/25'	na	15'/25'	na	15'/25'	20'/25'
	Upper Story Setback Above 51'; adjacent to Protected District: Rear, alley/Rear, no alley and Side Interior (min)	na	35'/40'	na	15'/25'	na	na	35'/40'
	Rooftop or Second Story Decks	See Section 5.3.5.2						
<b>STREET LEVEL ACTIVATION</b>								
I	Transparency, Primary Street (min)					40%		
	Transparency, Side Street (min)					25%		
J	Pedestrian Access	Each Dwelling Unit Oriented to the Street shall have Dwelling Unit Entrance with Entry Feature						
<b>USES</b>		All U-RX Zone Districts		All U-MX Zone Districts		All U-MS Zone Districts		
	Street Level Active Uses (min % of Primary Street frontage meeting Build-To requirement)	na		40%		100%		
	Permitted Primary Uses	Primary Uses shall be limited to Two Unit Dwelling, Multi Unit Dwelling (3+), and Live / Work Dwelling uses. See Div. 5.4, Uses, <del>and Required</del> <b>Minimum Parking</b>						

See Sections 5.3.5 - 5.3.7 for Supplemental Design Standards, Design Standard Alternatives and Design Standard Exceptions

## APARTMENT

<b>HEIGHT</b>		U-RH-3A*
A	Stories (max)	3
A	Feet (max)	38'

<b>SITING</b>		U-RH-3A*
<b>ZONE LOT</b>		
	Zone Lot Area (min/max)	6,000 sf / 16,000 sf
	Zone Lot Width (min)	50'
<b>SETBACKS</b>		
B	Primary Street (min)	Calculated per Sec. 13.1.5.9
C	Side Street (min)	10'
D	Side Interior (min)	5'
E	Rear, where Alley (public or private) abuts a Rear Zone Lot Line (min)	12'
E	Rear, where Alley (public or private) does not abut a Rear Zone Lot Line (min)	20'
<b>PARKING</b>		
	Surface Parking between building and Primary Street/Side Street	Not Allowed/Allowed
	Vehicle Access	Shall be determined as part of Site Development Plan Review

<b>DESIGN ELEMENTS</b>		U-RH-3A*
<b>BUILDING CONFIGURATION</b>		
	Dwelling Unit Configuration	Structure may contain Side-by-Side Dwelling Units Residential Only Structure: Side-by-Side Dwelling Units shall not exceed 50% of the Structure's GFA
	Street-facing garage door width per Primary Structure (max)	20'
	Rooftop or Second Story Decks	See Section 5.3.5.2
<b>STREET LEVEL ACTIVATION</b>		
	Transparency, Primary Street (min)	40%
	Transparency, Side Street (min)	25%
F	Pedestrian Access, Primary Street or Side Street	Entrance

<b>USES</b>		U-RH-3A*
		Primary Uses shall be limited to Multi Unit Dwelling (3+), Live / Work Dwelling, and permitted Congregate Living, Residential Care, and Nonresidential uses. See Div. 5.4, Uses, <del>and</del> <b>Required Minimum Parking</b>

See Sections 5.3.5 - 5.3.7 for Supplemental Design Standards, Design Standard Alternatives, and Design Standard Exceptions.

\*Form is permitted ONLY on corner zone lots where at least one of the intersecting streets is a collector or arterial street, according to the functional street classifications adopted by the Department of Transportation and Infrastructure ("DOTI").

## DRIVE THRU SERVICES

APPLICABILITY		All U-MS, U-MX		
Form is not permitted on Zone Lots within 1/4 mile of the outer boundary of a Rail Transit Station Platform				
HEIGHT		U-MX-2 U-MS-2	U-MX-3 U-MS-3, -5	
Stories (max)		2	3	
Feet (max)		30'	45'	
SITING		U-MS-2, -3, -5	U-MX-2, -3 Option A	U-MX-2, -3 Option B**
REQUIRED BUILD-TO				
Primary Street (min % within min/max)*		50% 0'/15'	50% 0'/15'	na
Side Street (min % within min/max)*		50% 0'/15'	50% 0'/15'	na
SETBACKS				
Primary Street (min)		0'	0'	0'
Side Street (min)		0'	0'	0'
Side Interior (min)		0'	0'	0'
Side Interior, adjacent to Protected District (min)		10'	10'	10'
Rear, where an Alley (public or private) abuts a Rear Zone Lot Line (min)		0'	0'	0'
Rear, adjacent to Protected District, where an Alley (public or private) does not abut a Rear Zone Lot Line (min)		0'	0'	0'
Rear, adjacent to Protected District, where Alley (public or private) does not abut a Rear Zone Lot Line		10'	10'	10'
PARKING				
Surface Parking between building and Primary Street/Side Street		Not Allowed/Not Allowed	Not Allowed/Allowed	Allowed/Allowed
Vehicle Access		Shall be determined as part of Site Development Plan Review		
DESIGN ELEMENTS		U-MS-2, -3, -5	U-MX-2, -3 Option A	U-MX-2, -3 Option B**
BUILDING CONFIGURATION				
A *Canopy		Building shall be used to meet a portion of the Primary and Side Street Build-To. Canopy may be used to meet a portion of the Primary and Side Street Build-To	Building shall be used to meet a portion of the Primary or Side Street Build-To. Canopy may be used to meet a portion of the Primary and Side Street Build-To	na
B Screening Required		Garden Wall required within 0'/15' for 100% of the zone lot's Primary and Side Street frontages, excluding access points and portions of building within 0'/15'; following the standards of Article 10, Sec. 10.5.4.4		
Upper Story Setback Above 27' adjacent to Protected District: Rear, alley/Rear, no alley and Side Interior (min)		U-MS-3, -5 Only: 15'/25'	U-MX-3 Only: 15'/25'	U-MX-3 Only: 15'/25'
STREET LEVEL ACTIVATION				
C Transparency, Primary Street (min)		60%	40%	40%
D Transparency, Side Street (min)		25%	25%	25%
E Pedestrian Access, Primary Street		Entrance	Entrance	Pedestrian Connection
USES		U-MS-2, -3, -5; U-MX-2, -3**		
For Primary Structures constructed on or before June 25, 2010, all permitted Primary Uses shall be allowed within this building form; however, for Primary Structures constructed after June 25, 2010, Primary Uses shall be limited to an Automobile Services, Light Primary Use with Accessory Drive Thru Use, excluding Eating & Drinking Establishments. See Div. 5.4, Uses <b>and Required Minimum Parking</b> . **Additionally, in U-MX-2, 3 Option B is limited to Gasoline Service Station Use Only				



## DRIVE THRU RESTAURANT

### APPLICABILITY

All U-MS, U-MX

Form is not permitted on Zone Lots within 1/4 mile of the outer boundary of a Rail Transit Station Platform

### HEIGHT

	U-MX-2 U-MS -2	U-MX-3 U-MS-3, -5
Stories (max)	2	3
Feet (max)	30'	45'

### SITING

#### REQUIRED BUILD-TO

	U-MS-2, -3, -5	U-MX-2, -3
Primary Street (min % within min/max)	Corner Lots: 50% 0'/5' All other: 75% 0'/5'	Corner Lots: 50% 0'/35' All other: 70% 0'/35'
Side Street (min % within min/max)	50% 0'/5'	50% 0'/18'

#### SETBACKS

	U-MS-2, -3, -5	U-MX-2, -3
Primary Street (min)	0'	0'
Side Street (min)	0'	0'
Side Interior (min)	0'	0'
Side Interior, adjacent to Protected District (min)	10'	10'
Rear, where an Alley (public or private) abuts a Rear Zone Lot Line (min)	0'	0'
Rear, adjacent to Protected District, where Alley (public or private) abuts a Rear Zone Lot Line (min)	0'	0'
Rear, adjacent to Protected District, where Alley (public or private) does not abut a Rear Zone Lot Line (min)	10'	10'

#### PARKING

	Surface Parking between building and Primary Street/Side Street	Not Allowed/Not Allowed	Not Allowed/Not Allowed
<b>A</b>	Drive Thru Lane between building and Primary Street/Side Street	Not Allowed/Not Allowed	Allowed/Allowed
	Drive Thru Lane Width (max)	n/a	12'
<b>B</b>	Drive Thru Lane Screening Required	n/a	Garden Wall, following the standards of Section 10.5.4.4
	Vehicle Access	Shall be determined as part of Site Development Plan Review	

### DESIGN ELEMENTS

#### BUILDING CONFIGURATION

	U-MS-2, -3, -5	U-MX-2, -3
Upper Story Setback Above 27' adjacent to Protected District: Rear, alley/Rear, no alley and Side Interior (min)	15'/25'	15'/25'

#### STREET LEVEL ACTIVATION

<b>C</b>	Transparency, Primary Street (min)	60%	40%
<b>D</b>	Transparency, Side Street (min)	25%	25%
<b>E</b>	Pedestrian Access, Primary Street	Entrance	Entrance and Pedestrian Connection

### USES

U-MS-2, -3, -5; U-MX-2, -3

For Primary Structures constructed on or before June 25, 2010, all permitted Primary Uses shall be allowed within this building form; however, for Primary Structures constructed after June 25, 2010, Primary Uses shall be limited to an Eating & Drinking Establishment Primary Use with Accessory Drive Thru Use Only. See Div. 5.4, Uses **and Required Minimum Parking**.

## GENERAL

HEIGHT	U-MX-2, -2x	U-MX-3
Stories (max)	2	3
Feet (max)	30'	45'
Stories/Feet, with incentives (max)	na	4/55' See Section 10.12.1, Height Incentives

SITING	U-MX-2, -2x	U-MX-3
<b>REQUIRED BUILD-TO</b>		
A Primary Street (min build-to % within min/max range)	70% 0'/15'	70% 0'/15'
Side Street (min build-to % within min/max range)	na	na
<b>SETBACKS</b>		
Primary Street (min)	0'	0'
Side Street (min)	0'	0'
Side Interior (min)	0'	0'
B Side Interior, adjacent to Protected District (min)	U-MX-2x: 5' 10'	10'
Rear (min)	0'	0'
Rear, adjacent to Protected District, where Alley (public or private) abuts a Rear Zone Lot Line (min)	U-MX-2x: 12' All Other Zone Districts: 0'	0'
Rear, adjacent to Protected District, where Alley (public or private) does not abut a Rear Zone Lot Line (min)	U-MX-2x: 20' All Other Zone Districts: 10'	10'
<b>PARKING</b>		
C Surface Parking between building and Primary Street/Side Street	Not Allowed/Allowed	
D Surface Parking Screening	See Division 10.5, Landscaping, Fences, Walls and Screening	
Vehicle Access	Shall be determined as part of Site Development Plan Review	

DESIGN ELEMENTS	U-MX-2, -2x	U-MX-3
<b>BUILDING CONFIGURATION</b>		
Dwelling Unit Configuration	Structure may contain Side-by-Side Dwelling Units Residential Only Structure: Side-by-Side Dwelling Units shall not exceed 50% of the Structure's GFA	
E Upper Story Setback Above 27' adjacent to Protected District: Rear, alley/Rear, no alley and Side Interior (min)	na	15'/25'
<b>STREET LEVEL ACTIVATION</b>		
F Transparency, Primary Street (min)	40%	40%
G Transparency, Side Street (min)	25%	25%
Transparency Alternatives	See Section 5.3.6.2	
H Pedestrian Access, Primary Street	Entrance	
<b>USES</b>		
Street Level Active Uses (min % of Primary Street frontage meeting Build-To requirement)	40%	

Permitted Primary Uses All permitted Primary Uses shall be allowed within this building form.  
See Division 5.4, Uses, and Required Minimum Parking

See Sections 5.3.5 - 5.3.7 for Supplemental Design Standards, Design Standard Alternatives and Design Standard Exceptions

# SHOPFRONT

			U-MS-2 U-MS-2x U-MX-2 U-MX-2x	U-MS-3 U-MX-3	U-MS-5
<b>HEIGHT</b>	<b>U-RX-3</b>	<b>U-RX-5</b>			
Stories (max)	3	5	2	3	5
<b>A</b> Feet (min/max)	na/45'	na/70'	na/30'	na/45'	24'/70'
Stories/Feet, with incentives (max)	4/55'	7/95'	na	4/55'	7/95'
Feet, within 175' of Protected District (max)	na	75'	na	na	75'
			U-MS-2 U-MS-2x U-MX-2 U-MX-2x	U-MS-3 U-MX-3	U-MS-5
<b>SITING</b>	<b>U-RX-3</b>	<b>U-RX-5</b>			
<b>REQUIRED BUILD-TO</b>					
<b>B</b> Primary Street (min build-to % within min/max range)	70% 0'/15'	70% 0'/15'	75% 0'/5' Residential Only Buildings: 0'/10'		
<b>C</b> Side Street (min build-to % within min/max range)	na	na	25% 0'/5' Residential Only Buildings: 0'/10'		
<b>SETBACKS</b>					
Primary Street (min)	0'	0'	0'	0'	0'
Side Street (min)	0'	0'	0'	0'	0'
Side Interior (min)	0'	0'	0'	0'	0'
<b>D</b> Side Interior, adjacent to Protected District (min)	10'	10'	U-MS-2x, U-MX-2x: 5' All Other Zone Districts: 10'	10'	10'
Rear, with or without an Alley (public or private) (min)	0'	0'	0'	0'	0'
Rear, adjacent to Protected District, where Alley (public or private) abuts a Rear Zone Lot Line (min)	0'	0'	U-MS-2x, U-MX-2x: 12' All Other Zone Districts: 0'	0'	0'
Rear, adjacent to Protected District, where Alley (public or private) does not abut a Rear Zone Lot Line (min)	10'	10'	U-MS-2x, U-MX-2x: 20' All Other Zone Districts: 10'	10'	10'
<b>PARKING</b>					
Surface Parking between building and Primary Street/Side Street	Not Allowed/Not Allowed				
<b>E</b> Surface Parking Screening	See Div. 10.5, Landscaping, Fences, Walls and Screening				
Vehicle Access	Shall be determined as part of Site Development Plan Review				
			U-MS-2 U-MS-2x U-MX-2 U-MX-2x	U-MS-3 U-MX-3	U-MS-5
<b>DESIGN ELEMENTS</b>	<b>U-RX-3</b>	<b>U-RX-5</b>			
<b>BUILDING CONFIGURATION</b>					
Dwelling Unit Configuration	Structure may contain Side-by-Side Dwelling Units Residential Only Structure: Side-by-Side Dwelling Units shall not exceed 50% of the Structure's GFA				
<b>F</b> Upper Story Setback Above 27' adjacent to Protected District: Rear, alley/Rear, no alley and Side Interior (min)	15'/25'	20'/25'	na	15'/25'	20'/25'
<b>G</b> Upper Story Setback Above 51' adjacent to Protected District: Rear, alley/Rear, no alley and Side Interior (min)	na	35'/40'	na	na	35'/40'
<b>STREET LEVEL ACTIVATION</b>					
<b>H</b> Transparency, Primary Street (min)	60%, Residential Only Buildings: 40%				
<b>I</b> Transparency, Side Street (min)	25%				
<b>J</b> Pedestrian Access, Primary Street	Entrance				
<b>USES</b>	<b>All U-RX Zone Districts</b>		<b>All U-MS and U-MX Zone Districts</b>		
Street Level Active Uses (min % of Primary Street frontage meeting Build-To requirement)	na		100%		
	All permitted Primary Uses shall be allowed within this building form; however: (1) Second Story and Above: Residential or Lodging Accommodations Uses Only; and (2) Buildings with No Residential or Lodging Accommodation Uses: 10,000 sf GFA max. See Div. 5.4.		All permitted Primary Uses shall be allowed within this building form. See Div. 5.4, Uses, <b>and Required Minimum Parking</b>		

See Sections 5.3.5 - 5.3.7 for Supplemental Design Standards, Design Standard Alternatives and Design Standard Exceptions

## GENERAL DETACHED STRUCTURE

Examples of General Detached Structures include garages, sheds, and gazebos. The General Detached Structure building form provides standards for structures accessory to a primary structure that exceed the standards for a Minor Detached Structure.

<b>HEIGHT</b>		All U-SU, TU, RH	All U-RX, MX, MS
A	Stories (max)	1	1
A	Feet (max)	17'	17'
B	Bulk Plane Vertical Height at Side Interior and Side Street Zone Lot Line	10'	na
	Bulk Plane Slope from Side Interior and Side Street Zone Lot Line	45°	na

<b>SITING</b>		All U-SU, TU, RH	All U-RX, MX, MS
<b>SETBACKS AND BUILDING COVERAGE</b>			
C	Location of Structure	Located a minimum of 10' behind 75% of the total width of the Primary Street-facing facade(s) of one Primary Structure; see Section 13.1.5.12 for applicable location standard when there are multiple Primary Structures on one Zone Lot	
D	Side Street (min)	5'	5'
D	Side Interior (min), for structure entirely in rear 35% of zone lot*	0'	5'
	Side Interior (min), for structure not entirely in rear 35% of zone lot	5'	5'
	Side Interior (min), for structure not entirely in rear 35% of zone lot, where Zone Lot Width is 30' or less	3'	5'
E	Rear, no alley (min)	5'	5'
	Rear, alley, where garage doors face alley (min)	5'	5'
	Rear, alley, where garage doors do not face alley* (min)	0'	0'
	Building Coverage (max)	See maximum Building Coverage per Zone Lot in the Primary Structure building form table	
<b>PARKING</b>			
	Vehicle Access*	From Alley (public or private); or Street access allowed when no Alley present See Sec. 5.3.7.4 for exceptions	

<b>DESIGN ELEMENTS</b>		All U-SU	All U-TU	All U-RH	All U-RX, MX, MS
<b>BUILDING CONFIGURATION</b>					
	Building Footprint (max)	1,000 sf	1000 sf per unit**	1000 sf per unit**	na
F	Overall Structure Length (max)	36'	36' per unit	no max	na
	Gross Floor Area (max)	na	na	na	See Section 5.3.4.3.C
	Allowed Number of Primary Street Facing Vehicular Access Doors in the front 50% of the lot depth (max)	3	3	3	na
G	Cumulative Width of All Primary Street Facing Vehicular Access Doors in the front 50% of the lot depth (max)	28'	28'	no max	na

<b>USES</b>		All U-SU, TU, RH, RX, MX, MS			
		Accessory Uses Only, excluding accessory dwelling unit where permitted. See Div. 5.4 for permitted Accessory Uses, <del>and Required Minimum Parking</del>			
See Sections 5.3.5 - 5.3.7 for Supplemental Design Standards, Design Standard Alternatives, and Design Standard Exceptions.					

\* See Section 10.4.6, Vehicle Parking Design, for standards that may be more restrictive.

BUILDING FEATURES	ZONE DIS-TRICTS	THE AGGRE-GATE SHALL NOT EXCEED 33-1/3 PER-CENT OF THE AREA OF THE SUPPORTING ROOF	SHALL BE SET BACK FROM THE PERIMETER OF THE BUILDING A MINIMUM OF ONE FOOT HORIZONTALLY FOR EVERY ONE FOOT OF VERTICAL HEIGHT	MAY EXCEED MAXIMUM HEIGHT IN FEET BY:	MAY EXCEED MAXIMUM HEIGHT IN STORIES BY:	MAY PROJECT THROUGH THE BULK PLANE	MAY EXCEED UPPER STORY SETBACK HEIGHT BY
Elevator lobbies	All 5-Story U-RX, U-MS Zone Districts	Yes	Yes	28'	1 story	Not allowed	Not allowed
Open Structures	All 3-Story or lower U-RX, U-MX, U-MS Zone Districts	Yes	Yes	12'	Not applicable	Not allowed	Not allowed
Open Structures	All 5-Story U-RX, U-MS Zone Districts	Yes	Yes	28'	Not applicable	Not allowed	Not allowed
Parapet Wall or Safety Railing	All 3-Story or lower U-RX, U-MX, U-MS Zone Districts	No	No	Not allowed	Not applicable	Not allowed	4'
Parapet Wall or Safety Railing	All 5-Story U-MS Zone Districts	No	No	Any distance	Not applicable	Not allowed	4'
Solar panels	All U- Zone Districts	No	No	Any distance	Not applicable	Any distance	Any distance
Evaporative coolers	All U- Zone Districts	No	Yes	Any distance	Not applicable	Any distance	Any distance
Accessory water tanks	All U-MX, U-MS Zone Districts	No	Yes	28'	Not applicable	Any distance	Any distance
Pedestrian bridge	All U- Zone Districts	Not appli-cable	Not applicable	28'	Any number	Any distance	Any distance

### 5.3.7.2 Setback Exceptions - Architectural, Site, Service & Utility Elements

#### A. Intent

To allow minor elements to encroach into a setback while maintaining an open and unobstructed minimum setback.

#### B. Standard

Except as specifically allowed below, Setbacks specified in the applicable Building Form tables shall be open and unobstructed.

#### C. Exceptions

The following Structures or portions of Structures are permitted to encroach into the Setbacks subject to the limitations in the tables below. No portion of a Structure that encroaches into the Setbacks shall extend into a required Setback beyond the maximum Setback encroachment distance specified in the tables below, as measured perpendicular to the respective Zone Lot line. Where more than one Setback encroachment is allowed for the same Structure or portion of a Structure, the permitted Setback encroachment distances shall not be cumulative. See "Height Exceptions" for encroachments related to Upper Story Setbacks.

##### 1. Architectural Elements

To allow for minor elements which add to the architectural character of buildings, while maintaining an open and unobstructed setback.

	ZONE DISTRICTS	BUILDING FORMS	PRIMARY STREET	SIDE STREET	SIDE INTERIOR	REAR
<p>Rooftop or Second Story Decks, above grade stairways equal to or less than 4 feet in width, and landings equal to or less than 16 square feet in area.</p> <ul style="list-style-type: none"> <li>All sides shall be at least 50% open except for any side abutting a building facade or fire wall.</li> </ul> <p>*Exception applies when the Rear Zone Lot Line abuts an Alley or Street.</p>	All U- Zone Districts	Detached Accessory Dwelling Unit	Not allowed	5'	Not allowed	5'*
<p>Intent: To allow for second story exterior building entrances and an outdoor space allowance for detached ADU uses.</p>	<p style="text-align: right;">Not to Scale. Illustrative Only.</p>					
<p style="text-align: center;">Illustrative only</p>						

**2. Site Elements**

To allow for minor screening and parking elements while maintaining an open and unobstructed setback.

	ZONE DISTRICTS	BUILDING FORMS	PRIMARY STREET	SIDE STREET	SIDE INTERIOR	REAR
Fences and Walls	See Article 10, Division 10.5 Landscaping, Fences, Walls and Screening					
Off-Street Parking Area	All U-SU, U-TU, U-RH Zone Districts	Urban House, Duplex, and Tandem House	Any distance	Any distance	Any distance	Any distance
<p>Intent: To allow off-street parking where it is <b>not less</b> impactful <del>due to the number of required parking spaces.</del></p>	<p style="text-align: right;">Not to Scale. Illustrative Only.</p>					

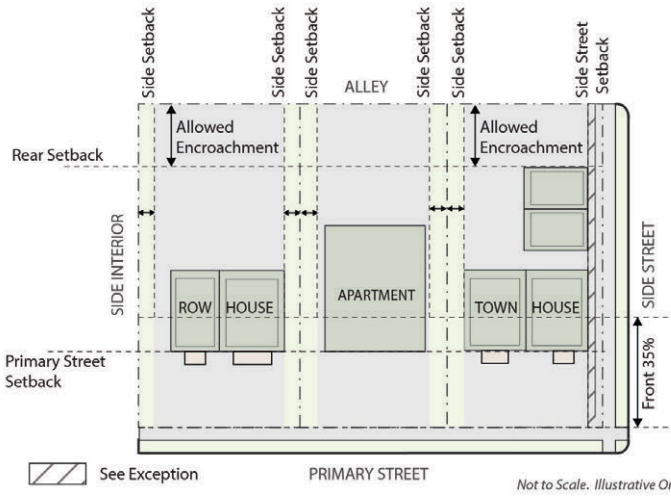
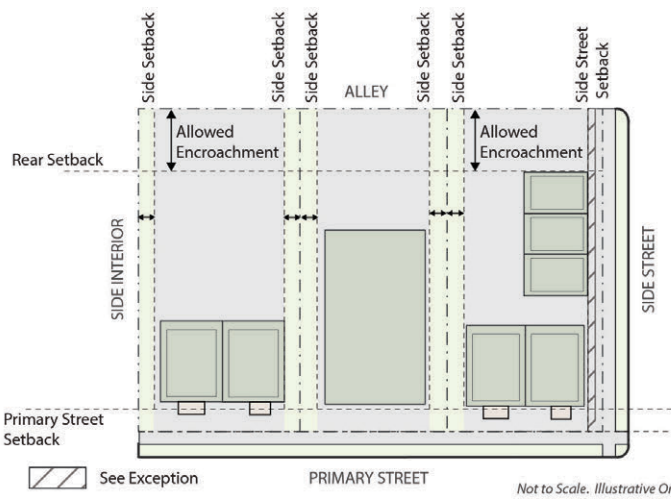
	ZONE DISTRICTS	BUILDING FORMS	PRIMARY STREET	SIDE STREET	SIDE INTERIOR	REAR
Off-Street Parking Area	All U-TU and U-RH Zone Districts	Row House and Apartment	Not allowed	Not allowed	Allowed within the rear 35% of the Zone Lot only	Any distance
<p>Intent: To restrict off-street parking where it is <b>more impactful due to the number of required parking spaces.</b></p> 						
	ZONE DISTRICTS	BUILDING FORMS	PRIMARY STREET	SIDE STREET	SIDE INTERIOR	REAR
Off-Street Parking Area	All U-RX, U-MX, and U-MS Zone Districts	Town House	Any distance	Not allowed* (*see exception below)	Any distance	Any distance
When a Zone Lot contains two or more building forms with different permitted encroachments, the less restrictive standards shall apply for the entire Zone Lot.		General and Shopfront	Any distance	Any distance	Any distance	Any distance
<p>Intent: To restrict off-street parking where it is <b>more impactful due to the number of required parking spaces.</b></p> 						
<p>*Exception: The minimum 5' of back out space required in Division 10.4, Parking and Loading, shall be permitted to encroach 2.5' when:</p> <ul style="list-style-type: none"> <li>The encroachment is screened from the Side Street with a Garden Wall and 1 deciduous canopy tree or minimum 5' wide planting strip landscaped with 50% live plant material as described in 10.5.4.6 Landscape Material Standards.</li> </ul>						

## DIVISION 5.4 USES ~~AND REQUIRED MINIMUM PARKING~~

### SECTION 5.4.1 APPLICABILITY

- 5.4.1.1 This Division 5.4 sets forth the land uses permitted; ~~and the~~ required zoning procedures ~~and the required minimum parking~~ for all the Urban Neighborhood Context zone districts.
- 5.4.1.2 Uses not listed are prohibited, unless the Zoning Administrator specifically permits the unlisted use according to Section 12.4.6, Code Interpretations and Determination of Unlisted Uses.
- 5.4.1.3 For number of primary and accessory uses allowed per zone lot, see Section 1.2.3.5, Number of Structures and Uses Allowed per Zone Lot.

### SECTION 5.4.2 ORGANIZATION

#### 5.4.2.1 Organized by Primary, Accessory and Temporary Uses

The Use ~~and Parking~~ Table first presents all primary uses, then all accessory uses, and finally all temporary uses. Primary uses are arranged hierarchically within the table by use classification, category of primary uses, and then by specific use type. Accessory uses are organized by whether such use is accessory to a primary residential use or to a primary nonresidential use. Temporary uses are presented alphabetically ordered in the last division of the table.

#### 5.4.2.2 Primary Use Classifications, Categories & Specific Use Types

##### A. Primary Use Classifications

All primary land uses in the Use ~~and Parking~~ Table are organized into one of the following five general land use classifications:

1. Residential Uses
2. Civic, Public & Institutional Uses
3. Commercial Sales, Service & Repair Uses
4. Industrial, Manufacturing & Wholesale Uses
5. Agriculture

##### B. Primary Use Categories & Specific Use Types

Primary uses are further organized into use categories and specific use types listed under each general primary land use classification. The Use ~~and Parking~~ Table is organized into the above five general land use classifications, use categories and specific use types.

##### C. Classifications & Categories Are Mutually Exclusive

The general land use classifications and use categories listed in the Use ~~and Parking~~ Table are intended to be mutually exclusive; that is, a use classified into one use category, such as “lodging accommodations,” cannot be classified in a different use category, such as “congregate living,” unless otherwise expressly allowed by this Code.

### SECTION 5.4.3 EXPLANATION OF TABLE ABBREVIATIONS

#### 5.4.3.1 General Explanation of Table Cell Entries

In each of the table cells, the entry will indicate first whether use limitations apply to the specific use, and then separated by a hyphen, the type of zoning review required prior to establishment of the use under this Code. For example, as described in more detail below, a cell entry “L-ZPIN” means, first, the use is subject to use limitations (the “L”), and, second, that the use is subject to zoning permit review with information notice (the “ZPIN”) prior to its establishment.



### 5.4.3.2 Permitted, Limited, Not Permitted

#### A. Permitted Use - No Use Limitations Apply (“P”)

A “P” in a table cell indicates that the use is permitted in the respective zone district, and is not subject to use limitations.

#### B. Permitted Use - Subject to Use Limitations (“L”)

“L” in a table cell indicates the use is permitted in the zone district subject to compliance with the use limitations referenced in the last column of the use table (“Applicable Use Limitations”).

#### C. Uses Not Permitted (“NP”)

“NP” in a table cell indicates that the use is not permitted in the specific zone district.

### 5.4.3.3 Zoning Procedure

#### A. Use Subject to Zoning Permit Review (“ZP”)

“ZP” in a table cell indicates that the use is permitted in the respective zone district only if reviewed and approved according to the requirements in Section 12.4.1, Zoning Permit Review.

#### B. Use Subject to Zoning Permit Review with Informational Notice (“ZPIN”)

“ZPIN” in a table cell indicates that the use is permitted in the respective zone district only if reviewed and approved according to the public notice and procedural requirements in Section 12.4.2, Zoning Permit Review with Informational Notice. Such uses shall comply with any applicable use limitations noted in the last column of the use table (“Applicable Use Limitations”), as well as the review criteria stated in Section 12.4.2, Zoning Permit Review with Informational Notice.

#### C. Use Subject to Zoning Permit Review with Community Information Meeting (“ZPCIM”)

“ZPCIM” in a table cell indicates that the use is permitted in the respective zone district only if reviewed and approved according to the public notice and procedural requirements in Section 12.4.1, Zoning Permit Review. Prior to formal application, an applicant shall schedule a community information meeting and provide public notice of the community information meeting according to Section 12.3.4.6, Community Information Meeting.

#### D. Use Subject to Zoning Permit with Special Exception Review (“ZPSE”)

“ZPSE” in a table cell indicates that use is generally appropriate in the neighborhood context and zone district, yet may have the potential for limited impacts on adjacent properties or on the established character of the neighborhood context or zone district. “ZPSE” uses are subject to a Board of Adjustments public hearing according to Section 12.4.9, Zoning Permit with Special Exception Review, which grants the Board of Adjustment the authority to impose conditions on the specified use to mitigate any potential impacts. Such uses shall comply with any applicable use limitations noted in the last column of the use table (“Applicable Use Limitations”), as well as the review criteria stated in Section 12.4.9, Zoning Permit with Special Exception Review.

#### E. Uses Where More Than One Zoning Procedure Is Indicated

Where a table cell shows more than one zoning procedure applies to a use, for example “L-ZP/ZPIN”, the referenced use limitation (last table column) will indicate which zoning procedure applies in a specific case. For example, a table cell may indicate “L-ZPIN/ZPSE” for a use. This means that the ZPIN zoning procedure will apply, unless the applicable use limitation specifies the ZPSE zoning procedure is triggered (e.g., by proximity to a Protected District).

### 5.4.3.4 Enclosure of Uses

All primary, accessory and temporary uses must be established, operated and maintained within a Completely Enclosed Structure, unless otherwise specifically allowed by this Code. The Use ~~and~~ **Parking** Tables in Articles 3-9 indicate when a use may be established, operated or maintained outside a Completely Enclosed Structure by including an asterisk “\*” next to the specific use type. For example, the asterisk following the “Telecommunication Tower\*” use type in the tables indicates that a telecommunication tower land use need not be enclosed.

## SECTION 5.4.4 DISTRICT SPECIFIC STANDARDS

KEY: \* = Need Not be Enclosed P = Permitted Use without Limitations L = Permitted Use with Limitations NP = Not Permitted Use ZP = Zoning Permit Review  
ZPCIM = Subject to Zoning Permit Review with Community Information Meeting ZPIN = Subject to Zoning Permit Review with Informational Notice  
ZPSE = Subject to Zoning Permit with Special Exception Review When no ZP, ZPCIM, ZPIN, ZPSE listed = No Zoning Permit required

USE CATEGORY	SPECIFIC USE TYPE  • <del>Vehicle Parking Reqmt: # spaces per unit of measurement</del> • <del>Bicycle Parking Reqmt Requirement: # spaces per unit of measurement (% Required Spaces in Enclosed Facility /% Required Spaces in Fixed Facility)</del>									APPLICABLE USE LIMITATIONS	
		U-SU-A U-SU-A2 U-SU-B U-SU-B2 U-SU-C U-SU-C2 U-SU-E U-SU-H	U-TU-B U-TU-B2 U-TU-C	U-RH-2.5 U-RH-3A	U-RX-3 U-RX-5	U-MX-2x U-MS-2x	U-MX-2 U-MS-2	U-MX-3	U-MS-3 U-MS-5		
<b>RESIDENTIAL PRIMARY USE CLASSIFICATION</b>											
Household Living	Dwelling, Single Unit • <del>No Parking Requirements</del>	L-ZP	L-ZP	L-ZP	L-ZP	L-ZP	L-ZP	L-ZP	L-ZP	L-ZP	\$11.2.7
	Dwelling, Two Unit • <del>Vehicle: 1/unit</del> • <del>Bicycle: No requirement</del>	L-ZP	L-ZP	L-ZP	L-ZP	L-ZP	L-ZP	L-ZP	L-ZP	L-ZP	\$11.2.2; \$11.2.7
	Dwelling, Multi-Unit • <del>Vehicle: 1/unit</del> • <del>Bicycle: 1/4 units (80/20)</del>	L-ZP	L-ZP	L-ZP	L-ZP	L-ZP	L-ZP	L-ZP	L-ZP	L-ZP	\$11.2.3; \$11.2.7
	Dwelling, Live / Work • <del>Vehicle: 1/unit</del> • <del>Bicycle: 1/4 units (80/20)</del>	NP	NP	NP	L-ZP	L-ZP	L-ZP	L-ZP	L-ZP	L-ZP	\$11.2.4; \$11.2.7
	Manufactured Home Community	NP	NP	NP	NP	NP	NP	NP	NP	NP	
Residential Care	Residential Care, Type 1 • <del>Vehicle: .5/1,000 sf GFA</del> • <del>Bicycle: No requirement</del>	L/L-ZP	L/L-ZP	L/L-ZP	L/L-ZP	L/L-ZP	L/L-ZP	L/L-ZP	L/L-ZP	L/L-ZP	\$11.2.8; \$11.2.9
	Residential Care, Type 2 • <del>Vehicle: .5/1,000 sf GFA</del> • <del>Bicycle: No requirement</del>	L-ZPCIM	L-ZPCIM	L-ZPCIM	L-ZP	L-ZP	L-ZP	L-ZP	L-ZP	L-ZP	\$11.2.8; \$11.2.10
	Residential Care, Type 3 • <del>Vehicle: .5/1,000 sf GFA</del> • <del>Bicycle: No requirement</del>	NP	NP	NP	L-ZPCIM	NP	NP	L-ZPCIM	L-ZPCIM	L-ZPCIM	\$11.2.8; \$11.2.11
	Residential Care, Type 4 • <del>Vehicle: .5/1,000 sf GFA</del> • <del>Bicycle: No requirement</del>	NP	NP	NP	NP	NP	NP	L-ZPCIM	L-ZPCIM	L-ZPCIM	\$11.2.8; \$11.2.12
Congregate Living	All Types • <del>Vehicle: 1/1,000 sf GFA</del> • <del>Bicycle: 1/20,000 sf GFA</del>	NP	NP	U-RH-2.5: NP U-RH-3A: P-ZP	P-ZP	P-ZP	P-ZP	P-ZP	P-ZP	P-ZP	\$11.2.2

KEY: \* = Need Not be Enclosed P = Permitted Use without Limitations L = Permitted Use with Limitations NP = Not Permitted Use ZP = Zoning Permit Review  
 ZPCIM = Subject to Zoning Permit Review with Community Information Meeting ZPIN = Subject to Zoning Permit Review with Informational Notice  
 ZPSE = Subject to Zoning Permit with Special Exception Review When no ZP, ZPCIM, ZPIN, ZPSE listed = No Zoning Permit required

USE CATEGORY	SPECIFIC USE TYPE	APPLICABLE USE LIMITATIONS																			
	<ul style="list-style-type: none"> <li>Vehicle Parking Reqmt: # spaces per unit of measurement</li> <li>Bicycle Parking Reqmt Requirement: # spaces per unit of measurement (% Required Spaces in Enclosed Facility / % Required Spaces in Fixed Facility)</li> </ul>	U-SU-A	U-SU-A2	U-SU-B	U-SU-B2	U-SU-C	U-SU-C2	U-TU-B	U-TU-B2	U-RH-2.5	U-RH-3A	U-RX-3	U-RX-5	U-MX-2x	U-MX-2	U-MX-3	U-MS-3	U-MS-5			
<b>CIVIC, PUBLIC &amp; INSTITUTIONAL PRIMARY USE CLASSIFICATION</b>																					
Basic Utilities	Utility, Major Impact* <ul style="list-style-type: none"> <li>Vehicle: .5/1,000 sf GFA</li> <li>Bicycle: No requirement</li> </ul>	L-ZPSE	L-ZPSE	L-ZPSE	L-ZPSE	L-ZPSE	L-ZPSE	L-ZPSE	L-ZPSE	L-ZPSE	L-ZPSE	L-ZPSE	L-ZPSE	L-ZPSE	L-ZPSE	L-ZPSE	L-ZPSE	L-ZPSE	L-ZPSE	§ 11.3.1	
	Utility, Minor Impact* <ul style="list-style-type: none"> <li>Vehicle: .5/1,000 sf GFA</li> <li>Bicycle: No requirement</li> </ul>	L-ZP	L-ZP	L-ZP	L-ZP	L-ZP	L-ZP	L-ZP	L-ZP	L-ZP	L-ZP	L-ZP	L-ZP	L-ZP	L-ZP	L-ZP	L-ZP	L-ZP	L-ZP	L-ZP	§ 11.3.2
Community/ Public Services	Community Center* <ul style="list-style-type: none"> <li>Vehicle: .5/1,000 sf GFA</li> <li>Bicycle: 1/10,000 sf GFA (0/100)</li> </ul>	L-ZP	L-ZP	L-ZP	L-ZP	L-ZP	L-ZP	L-ZP	L-ZP	L-ZP	L-ZP	L-ZP	L-ZP	L-ZP	L-ZP	L-ZP	L-ZP	L-ZP	L-ZP	§ 11.3.3	
	Day Care Center <ul style="list-style-type: none"> <li>Vehicle: 1/1,000 sf GFA</li> <li>Bicycle: 1/10,000 sf GFA (0/100)</li> </ul>	L-ZP	L-ZP	P-ZPIN	P-ZPIN	P-ZPIN	P-ZPIN	P-ZPIN	P-ZPIN	P-ZPIN	P-ZPIN	P-ZPIN	P-ZPIN	P-ZPIN	P-ZPIN	P-ZPIN	P-ZPIN	P-ZPIN	P-ZPIN	P-ZPIN	§ 11.3.4
	Postal Facility, Neighborhood <ul style="list-style-type: none"> <li>Vehicle: 2.5/1,000 sf GFA</li> <li>MS only: 2/1,000 sf GFA</li> <li>Bicycle: 1/10,000 sf GFA (20/80)</li> </ul>	NP	NP	NP	P-ZP	P-ZP	P-ZP	P-ZP	P-ZP	P-ZP	P-ZP	P-ZP	P-ZP	P-ZP	P-ZP	P-ZP	P-ZP	P-ZP	P-ZP	P-ZP	
	Postal Processing Center <ul style="list-style-type: none"> <li>Vehicle: 1/1,000 sf GFA</li> <li>Bicycle: 1/10,000 sf GFA (20/80)</li> </ul>	NP	NP	NP	P-ZP	NP	NP	NP	NP	NP	NP	NP	NP	NP	NP	NP	NP	NP	NP	NP	
	Public Safety Facility <ul style="list-style-type: none"> <li>Vehicle: 1/1,000 sf GFA</li> <li>Bicycle: 1/10,000 sf GFA (0/100)</li> </ul>	L-ZP	L-ZP	L-ZP	L-ZP	L-ZP	L-ZP	L-ZP	P-ZP	P-ZP	P-ZP	P-ZP	P-ZP	P-ZP	P-ZP	P-ZP	P-ZP	P-ZP	P-ZP	P-ZP	§ 11.3.5
	Hospital	NP	NP	NP	NP	NP	NP	NP	NP	NP	NP	NP	NP	NP	NP	NP	NP	NP	NP	NP	
	Correctional Institution	NP	NP	NP	NP	NP	NP	NP	NP	NP	NP	NP	NP	NP	NP	NP	NP	NP	NP	NP	
Cultural/Special Purpose/Public Parks & Open Space	Cemetery*	NP	NP	NP	NP	NP	NP	NP	NP	NP	NP	NP	NP	NP	NP	NP	NP	NP	NP		
	Library <ul style="list-style-type: none"> <li>Vehicle: 1/1,000 sf GFA</li> <li>Bicycle: 1/10,000 sf GFA (0/100)</li> </ul>	P-ZP	P-ZP	P-ZP	P-ZP	P-ZP	P-ZP	P-ZP	P-ZP	P-ZP	P-ZP	P-ZP	P-ZP	P-ZP	P-ZP	P-ZP	P-ZP	P-ZP	P-ZP	P-ZP	
	Museum <ul style="list-style-type: none"> <li>Vehicle: 1/1,000 sf GFA</li> <li>Bicycle: 1/10,000 sf GFA (0/100)</li> </ul>	NP	NP	NP	P-ZP	P-ZP	P-ZP	P-ZP	P-ZP	P-ZP	P-ZP	P-ZP	P-ZP	P-ZP	P-ZP	P-ZP	P-ZP	P-ZP	P-ZP	P-ZP	
	City Park*	NP	NP	NP	NP	NP	NP	NP	NP	NP	NP	NP	NP	NP	NP	NP	NP	NP	NP	NP	
	Open Space - Conservation* <ul style="list-style-type: none"> <li>No Parking Requirements</li> </ul>	P-ZP	P-ZP	P-ZP	P-ZP	P-ZP	P-ZP	P-ZP	P-ZP	P-ZP	P-ZP	P-ZP	P-ZP	P-ZP	P-ZP	P-ZP	P-ZP	P-ZP	P-ZP	P-ZP	

KEY: \* = Need Not be Enclosed P = Permitted Use without Limitations L = Permitted Use with Limitations NP = Not Permitted Use ZP = Zoning Permit Review  
ZPCIM = Subject to Zoning Permit Review with Community Information Meeting ZPIN = Subject to Zoning Permit Review with Informational Notice  
ZPSE = Subject to Zoning Permit with Special Exception Review When no ZP, ZPCIM, ZPIN, ZPSE listed = No Zoning Permit required

USE CATEGORY	SPECIFIC USE TYPE <ul style="list-style-type: none"> <li>• <del>Vehicle Parking Reqmt: # spaces per unit of measurement</del></li> <li>• <del>Bicycle Parking Reqmt Requirement: # spaces per unit of measurement (% Required Spaces in Enclosed Facility /% Required Spaces in Fixed Facility)</del></li> </ul>	U-SU-A U-SU-A2 U-SU-B U-SU-B2 U-SU-C U-SU-C2 U-TU-B U-SU-E U-TU-B2 U-RH-2.5 U-RX-3 U-MX-2x U-MX-2 U-MS-3 U-SU-H U-TU-C U-RH-3A U-RX-5 U-MS-2x U-MS-2 U-MX-3 U-MS-5								APPLICABLE USE LIMITATIONS		
Education	Elementary or Secondary School <ul style="list-style-type: none"> <li>• <del>Vehicle-High School: 2/1,000 sf GFA</del></li> <li>• <del>Bicycle-High School: 1/10,000 sf GFA (0/100)</del></li> <li>• <del>Vehicle-All Others: 1/1,000 sf GFA</del></li> <li>• <del>Bicycle-All Others: 1/10,000 sf GFA (0/100)</del></li> </ul>	L-ZP	L-ZP	L-ZP	L-ZP	L-ZP	L-ZP	L-ZP	L-ZP	L-ZP	§ 11.3.8	
	University or College <ul style="list-style-type: none"> <li>• <del>Vehicle: 1/1,000 sf GFA</del></li> <li>• <del>Bicycle: 1/10,000 sf GFA (0/100)</del></li> </ul>	NP	NP	NP	L-ZP	NP	L-ZP	L-ZP	L-ZP	L-ZP	§ 11.3.8; § 11.3.9	
	Vocational or Professional School <ul style="list-style-type: none"> <li>• <del>Vehicle: 1/1,000 sf GFA</del></li> <li>• <del>Bicycle: 1/10,000 sf GFA (0/100)</del></li> </ul>	NP	NP	NP	L-ZP	L-ZP	L-ZP	L-ZP	L-ZP	L-ZP	§ 11.3.8	
Public and Religious Assembly	All Types <ul style="list-style-type: none"> <li>• <del>Vehicle: .5/1,000 sf GFA</del></li> <li>• <del>Bicycle: 1/10,000 sf GFA (0/100)</del></li> </ul>	L-ZP	L-ZP	L-ZP	L-ZP	L-ZP	P-ZP	P-ZP	P-ZP	P-ZP	§ 11.3.10	
COMMERCIAL SALES, SERVICES, & REPAIR PRIMARY USE CLASSIFICATION												
Adult Business	All Types	NP	NP	NP	NP	NP	NP	NP	NP	NP	NP	See Section 9.4.4, Use Overlay Districts, for adult business use allowance in the UO-1 District.

KEY: \* = Need Not be Enclosed P = Permitted Use without Limitations L = Permitted Use with Limitations NP = Not Permitted Use ZP = Zoning Permit Review  
 ZPCIM = Subject to Zoning Permit Review with Community Information Meeting ZPIN = Subject to Zoning Permit Review with Informational Notice  
 ZPSE = Subject to Zoning Permit with Special Exception Review When no ZP, ZPCIM, ZPIN, ZPSE listed = No Zoning Permit required

USE CATEGORY	SPECIFIC USE TYPE <ul style="list-style-type: none"> <li>• <del>Vehicle Parking Reqmt: # spaces per unit of measurement</del></li> <li>• <del>Bicycle Parking Reqmt Requirement: # spaces per unit of measurement (% Required Spaces in Enclosed Facility /% Required Spaces in Fixed Facility)</del></li> </ul>	SPECIFIC USE TYPE								APPLICABLE USE LIMITATIONS
		U-SU-A U-SU-A2 U-SU-B U-SU-B2 U-SU-C U-SU-C2 U-SU-E U-SU-H	U-TU-B U-TU-B2 U-TU-C	U-RH-2.5 U-RH-3A	U-RX-3 U-RX-5	U-MX-2x U-MS-2x	U-MX-2 U-MS-2	U-MX-3	U-MS-3 U-MS-5	
Arts, Recreation and Entertainment	Arts, Recreation and Entertainment Services, Indoor <ul style="list-style-type: none"> <li>• <del>Vehicle - Artist Studio: 0.3/1000 sf GFA</del></li> <li>• <del>Vehicle - All Others - MS only: 2/1,000 sf GFA</del></li> <li>• <del>Vehicle - All Others: 2.5/1,000 sf GFA</del></li> <li>• <del>Bicycle: 1/10,000 sf GFA (20/80)</del></li> </ul>	NP	NP	NP	P-ZP	L-ZPIN	L-ZP	P-ZP	P-ZP	§ 11.4.2
	Arts, Recreation and Entertainment Services, Outdoor* <ul style="list-style-type: none"> <li>• <del>Vehicle - MS only: 2/1,000 sf GFA</del></li> <li>• <del>Vehicle: 2.5/1,000 sf GFA</del></li> <li>• <del>Bicycle: 1/10,000 sf GFA (20/80)</del></li> </ul>	NP	NP	NP	L-ZPSE	NP	L-ZPSE	L-ZPSE	L-ZPSE	§ 11.4.3
	Event Space with Alternate Parking and Loading* <ul style="list-style-type: none"> <li>• <del>Vehicle: No requirement</del></li> <li>• <del>Bicycle: No requirement</del></li> </ul>	NP	NP	NP	NP	NP	NP	NP	NP	
	Sports and/or Entertainment Arena or Stadium*	NP	NP	NP	NP	NP	NP	NP	NP	
Nonresidential Uses in Existing Business Structures In Residential Zones ( <del>All Uses Shall Be Parked According to the Parking Requirement Stated in this Use Table for the Specific Nonresidential Use</del> )		L-ZP	L-ZP	L-ZP	Not Applicable					§11.4.6
Parking of Vehicles	Parking, Garage <ul style="list-style-type: none"> <li>• <del>No Parking Requirements</del></li> </ul>	NP	NP	NP	P-ZP	NP	P-ZP	P-ZP	P-ZP	
	Parking, Surface* <ul style="list-style-type: none"> <li>• <del>No Parking Requirements</del></li> </ul>	NP	L-ZP	L-ZP	NP	NP	NP	NP	NP	§ 11.4.8
Eating & Drinking Establishments	All Types <ul style="list-style-type: none"> <li>• <del>Vehicle: 4.5/1,000 sf GFA</del></li> <li>• <del>MS only: 2/1,000 sf GFA</del></li> <li>• <del>Bicycle: 1/5,000 sf GFA (0/100)</del></li> </ul>	NP	NP	NP	P-ZP	L-ZPSE	L-ZP	P-ZP	P-ZP	§ 11.4.9
Lodging Accommodations	Bed and Breakfast Lodging <ul style="list-style-type: none"> <li>• <del>Vehicle: 1/guest room or unit</del></li> <li>• <del>Bicycle: 1/10,000 sf GFA (60/40)</del></li> </ul>	NP	NP	NP	P-ZP	NP	P-ZP	P-ZP	P-ZP	
	Lodging Accommodations, All Others <ul style="list-style-type: none"> <li>• <del>Vehicle: 1/guest room or unit</del></li> <li>• <del>Bicycle: 1/10,000 sf GFA (60/40)</del></li> </ul>	NP	NP	NP	P-ZP	NP	NP	P-ZP	P-ZP	

KEY: \* = Need Not be Enclosed P = Permitted Use without Limitations L = Permitted Use with Limitations NP = Not Permitted Use ZP = Zoning Permit Review  
ZPCIM = Subject to Zoning Permit Review with Community Information Meeting ZPIN = Subject to Zoning Permit Review with Informational Notice  
ZPSE = Subject to Zoning Permit with Special Exception Review When no ZP, ZPCIM, ZPIN, ZPSE listed = No Zoning Permit required

USE CATEGORY	SPECIFIC USE TYPE  • <del>Vehicle Parking Reqmt: # spaces per unit of measurement</del> • <del>Bicycle Parking Reqmt Requirement: # spaces per unit of measurement (% Required Spaces in Enclosed Facility /% Required Spaces in Fixed Facility)</del>	U-SU-A U-SU-A2 U-SU-B U-SU-B2 U-SU-C U-SU-C2 U-TU-B U-SU-E U-TU-B2 U-RH-2.5 U-RX-3 U-MX-2x U-MX-2 U-MS-3 U-SU-H U-TU-C U-RH-3A U-RX-5 U-MS-2x U-MS-2 U-MX-3 U-MS-5									APPLICABLE USE LIMITATIONS
Office	Dental / Medical Office or Clinic • <del>Vehicle: 2/1,000 sf GFA</del> • <del>Bicycle: 1/10,000 sf GFA (60/40)</del>	NP	NP	NP	L-ZP	L-ZP	L-ZP	L-ZP	L-ZP	\$11.4.10	
	Office, All Others • <del>Vehicle: 2/1,000 sf GFA</del> • <del>Bicycle: 1/10,000 sf GFA (60/40)</del>	NP	NP	NP	P-ZP	P-ZP	P-ZP	P-ZP	P-ZP		
Retail Sales, Service & Repair (Not Including Vehicle or Equipment Sales, Service & Repair)	Animal Sales and Services, Household Pets Only • <del>Vehicle: 2.5/1,000 sf GFA</del> • <del>MS only: 2/1,000 sf GFA</del> • <del>Bicycle: 1/10,000 sf GFA (20/80)</del>	NP	NP	NP	L-ZP	L-ZPIN	L-ZP	L-ZP	L-ZP	\$11.4.12; \$11.4.11	
	Animal Sales and Services, All Others	NP	NP	NP	NP	NP	NP	NP	NP		
	Food Sales or Market • <del>Vehicle: 2.5/1,000 sf GFA</del> • <del>MS only: 2/1,000 sf GFA</del> • <del>Bicycle: 1/10,000 sf GFA (20/80)</del>	NP	NP	NP	L-ZP	L-ZP	L-ZP	P-ZP	P-ZP	\$11.4.14; \$11.4.11	
	Pawn Shop • <del>Vehicle: 2.5/1,000 sf GFA</del> • <del>MS only: 2/1,000 sf GFA</del> • <del>Bicycle: 1/10,000 sf GFA (20/80)</del>	NP	NP	NP	NP	NP	NP	NP	NP		
	Retail Sales, Service & Repair -- Outdoor* • <del>Vehicle: 2.5/1,000 sf GFA</del> • <del>MS only: 2/1,000 sf GFA</del> • <del>Bicycle: 1/10,000 sf GFA (20/80)</del>	NP	NP	NP	NP	L-ZPIN	L-ZPIN	L-ZPIN	L-ZP	\$11.4.16; \$11.4.11	
	Retail Sales, Service & Repair - Firearms Sales	NP	NP	NP	NP	NP	NP	NP	P-ZP		
	Retail Sales, Service & Repair, All Others • <del>Vehicle: 2.5/1,000 sf GFA</del> • <del>MS only: 2/1,000 sf GFA</del> • <del>Bicycle: 1/10,000 sf GFA (20/80)</del>	NP	NP	NP	P-ZP	L-ZP/L-ZPIN	L-ZP	P-ZP	P-ZP	\$11.4.11	

KEY: \* = Need Not be Enclosed P = Permitted Use without Limitations L = Permitted Use with Limitations NP = Not Permitted Use ZP = Zoning Permit Review  
 ZPCIM = Subject to Zoning Permit Review with Community Information Meeting ZPIN = Subject to Zoning Permit Review with Informational Notice  
 ZPSE = Subject to Zoning Permit with Special Exception Review When no ZP, ZPCIM, ZPIN, ZPSE listed = No Zoning Permit required

USE CATEGORY	SPECIFIC USE TYPE <ul style="list-style-type: none"> <li>• Vehicle Parking Reqmt: # spaces per unit of measurement</li> <li>• Bicycle Parking Reqmt Requirement: # spaces per unit of measurement (% Required Spaces in Enclosed Facility / % Required Spaces in Fixed Facility)</li> </ul>	SPECIFIC USE TYPE								APPLICABLE USE LIMITATIONS
		U-SU-A U-SU-A2 U-SU-B U-SU-B2 U-SU-C U-SU-C2 U-SU-E U-SU-H	U-TU-B U-TU-B2 U-TU-C	U-RH-2.5 U-RH-3A	U-RX-3 U-RX-5	U-MX-2x U-MS-2x	U-MX-2 U-MS-2	U-MX-3	U-MS-3 U-MS-5	
Vehicle / Equipment Sales, Rentals, Service & Repair	Automobile Emissions Inspection Facility <ul style="list-style-type: none"> <li>• Vehicle: .5/1,000 sf GFA</li> <li>• Bicycle: No requirement</li> </ul>	NP	NP	NP	NP	NP	L-ZP	P-ZP	P-ZP	§11.4.17
	Automobile Services, Light <ul style="list-style-type: none"> <li>• Vehicle: .5/1,000 sf GFA</li> <li>• Bicycle: No requirement</li> </ul>	NP	NP	NP	NP	NP	L-ZPSE	L-ZP	L-ZP	§11.4.18; §11.4.19
	Automobile Services, Heavy <ul style="list-style-type: none"> <li>• Vehicle: .5/1,000 sf GFA</li> <li>• Bicycle: No requirement</li> </ul>	NP	NP	NP	NP	NP	NP	NP	L-ZP/ZPSE	§11.4.18 §11.4.20
	Automobile / Motorcycle / Light Truck Sales, Rentals, Leasing; Pawn Lot or Vehicle Auctioneer* <ul style="list-style-type: none"> <li>• Vehicle: .5/1,000 sf GFA</li> <li>• Bicycle: No requirement</li> </ul>	NP	NP	NP	L-ZP	NP	NP	L-ZP	L-ZP	§11.4.21
	Heavy Vehicle/ Equipment Sales, Rentals & Service*	NP	NP	NP	NP	NP	NP	NP	NP	NP
<b>INDUSTRIAL, MANUFACTURING &amp; WHOLESALE PRIMARY USE CLASSIFICATION</b>										
Communications and Information	Antennas Not Attached to a Tower* <ul style="list-style-type: none"> <li>• No Parking Requirements</li> </ul>	L-ZP	L-ZP	L-ZP	L-ZP	L-ZP	L-ZP	L-ZP	L-ZP	§11.5.2
	Communication Services <ul style="list-style-type: none"> <li>• Vehicle: .5/1,000 sf GFA</li> <li>• Bicycle: No requirement</li> </ul>	NP	NP	NP	L-ZP/ZPSE	NP	L-ZP/ZPSE	L-ZP/ZPSE	U-MS-3: L-ZP/ZPSE U-MS-5: P-ZP	§11.5.1
	Telecommunications Towers* <ul style="list-style-type: none"> <li>• No Parking Requirements</li> </ul>	L-ZP/ ZPIN/ ZPSE	L-ZP/ ZPIN/ ZPSE	L-ZP/ZPIN/ ZPSE	L-ZP/ZPIN/ ZPSE	L-ZP/ ZPIN/ ZPSE	L-ZP/ ZPIN/ ZPSE	L-ZP/ ZPIN/ ZPSE	L-ZP/ZPIN/ ZPSE	§11.5.2
	Telecommunications Tower - Alternative Structure* <ul style="list-style-type: none"> <li>• No Parking Requirements</li> </ul>	L-ZP/ZPIN	L-ZP/ZPIN	L-ZP/ZPIN	L-ZP/ZPIN	L-ZP/ZPIN	L-ZP/ ZPIN	L-ZP/ ZPIN	L-ZP/ZPIN	§11.5.2
	Telecommunication Facilities -- All Others* <ul style="list-style-type: none"> <li>• No Parking Requirements</li> </ul>	L-ZPIN	L-ZPIN	L-ZPIN	L-ZPIN	L-ZPIN	L-ZPIN	L-ZPIN	L-ZPIN	§11.5.2
Industrial Services	Contractors, Special Trade - General <ul style="list-style-type: none"> <li>• Vehicle: .5/1,000 sf GFA</li> <li>• Bicycle: No requirement</li> </ul>	NP	NP	NP	NP	NP	NP	L-ZP	L-ZP	§11.5.3
	Contractors, Special Trade - Heavy/ Contractor Yard*	NP	NP	NP	NP	NP	NP	NP	NP	
	Food Preparation and Sales, Commercial <ul style="list-style-type: none"> <li>• Vehicle: .5/1,000 sf GFA</li> <li>• Bicycle: No requirement</li> </ul>	NP	NP	NP	L-ZP	L-ZPIN	L-ZPIN	L-ZP	L-ZP	§ 11.5.5
	Laboratory, Research, Development and Technological Services	NP	NP	NP	NP	NP	NP	L-ZP	L-ZP	§11.5.6
	Service/Repair, Commercial <ul style="list-style-type: none"> <li>• Vehicle: .5/1,000 sf GFA</li> <li>• Bicycle: No requirement</li> </ul>	NP	NP	NP	NP	NP	NP	L-ZP	L-ZP	§11.5.7

KEY: \* = Need Not be Enclosed P = Permitted Use without Limitations L = Permitted Use with Limitations NP = Not Permitted Use ZP = Zoning Permit Review  
ZPCIM = Subject to Zoning Permit Review with Community Information Meeting ZPIN = Subject to Zoning Permit Review with Informational Notice  
ZPSE = Subject to Zoning Permit with Special Exception Review When no ZP, ZPCIM, ZPIN, ZPSE listed = No Zoning Permit required

USE CATEGORY	SPECIFIC USE TYPE <ul style="list-style-type: none"> <li>• <b>Vehicle Parking Reqmt: # spaces per unit of measurement</b></li> <li>• <b>Bicycle Parking Reqmt Requirement: # spaces per unit of measurement (% Required Spaces in Enclosed Facility /% Required Spaces in Fixed Facility)</b></li> </ul>	U-SU-A U-SU-A2 U-SU-B U-SU-B2 U-SU-C U-SU-C2 U-TU-B U-SU-E U-TU-B2 U-RH-2.5 U-RX-3 U-MX-2x U-MX-2 U-MS-3 U-SU-H U-TU-C U-RH-3A U-RX-5 U-MS-2x U-MS-2 U-MX-3 U-MS-5									APPLICABLE USE LIMITATIONS
Manufacturing and Production	Manufacturing, Fabrication & Assembly -- Custom <ul style="list-style-type: none"> <li>• <b>Vehicle: .5 / 1,000 sf GFA</b></li> <li>• <b>Bicycle: No requirement</b></li> </ul>	NP	NP	NP	L-ZPIN	L-ZP	L-ZP	L-ZP	L-ZP		\$11.5.8
	Manufacturing, Fabrication & Assembly -- General <ul style="list-style-type: none"> <li>• <b>Vehicle: .5 / 1,000 sf GFA</b></li> <li>• <b>Bicycle: No requirement</b></li> </ul>	NP	NP	NP	NP	NP	NP	L-ZP/ ZPSE	L-ZP/ ZPSE		\$11.5.9
	Manufacturing, Fabrication & Assembly -- Heavy	NP	NP	NP	NP	NP	NP	NP	NP	NP	
Mining & Extraction and Energy Producing Systems	Oil, Gas -- Production, Drilling*	NP	NP	NP	NP	NP	NP	NP	NP	NP	
	Sand or Gravel Quarry*	NP	NP	NP	NP	NP	NP	NP	NP	NP	
	Wind Energy Conversion Systems* <ul style="list-style-type: none"> <li>• <b>No Parking Requirements</b></li> </ul>	L-ZPIN/ ZPSE	L-ZPIN/ ZPSE	L-ZPIN/ ZPSE	L-ZPIN/ ZPSE	L-ZPIN/ ZPSE	L-ZPIN/ ZPSE	L-ZPIN/ ZPSE	L-ZPIN/ ZPSE	L-ZPIN/ ZPSE	\$11.5.13
Transportation Facilities	Airport*	NP	NP	NP	NP	NP	NP	NP	NP	NP	
	Helipad, Helistop, Heliport* <ul style="list-style-type: none"> <li>• <b>No Parking Requirements</b></li> </ul>	L-ZPIN	L-ZPIN	L-ZPIN	L-ZPIN	L-ZPIN	L-ZPIN	L-ZP	L-ZP		\$11.5.14
	Railroad Facilities*	NP	NP	NP	NP	NP	NP	NP	NP	NP	
	Railway Right-of-Way* <ul style="list-style-type: none"> <li>• <b>No Parking Requirements</b></li> </ul>	P-ZP	P-ZP	P-ZP	P-ZP	P-ZP	P-ZP	P-ZP	P-ZP	P-ZP	
	Terminal, Station or Service Facility for Passenger Transit System <ul style="list-style-type: none"> <li>• <b>Vehicle: .5 / 1,000 sf GFA</b></li> <li>• <b>Bicycle: No requirement</b></li> </ul>	L-ZP	L-ZP	L-ZP	L-ZP	P-ZP	P-ZP	P-ZP	P-ZP	P-ZP	\$11.5.16
	Terminal, Freight, Air Courier Services	NP	NP	NP	NP	NP	NP	NP	NP	NP	
Waste Related Services	Automobile Parts Recycling Business*	NP	NP	NP	NP	NP	NP	NP	NP	NP	
	Junkyard*	NP	NP	NP	NP	NP	NP	NP	NP	NP	
	Recycling Center	NP	NP	NP	NP	NP	NP	NP	NP	NP	
	Recycling Collection Station	NP	NP	NP	NP	NP	NP	NP	NP	NP	
	Recycling Plant, Scrap Processor	NP	NP	NP	NP	NP	NP	NP	NP	NP	
Solid Waste Facility	NP	NP	NP	NP	NP	NP	NP	NP	NP		



KEY: \* = Need Not be Enclosed P = Permitted Use without Limitations L = Permitted Use with Limitations NP = Not Permitted Use ZP = Zoning Permit Review  
 ZPCIM = Subject to Zoning Permit Review with Community Information Meeting ZPIN = Subject to Zoning Permit Review with Informational Notice  
 ZPSE = Subject to Zoning Permit with Special Exception Review When no ZP, ZPCIM, ZPIN, ZPSE listed = No Zoning Permit required

USE CATEGORY	SPECIFIC USE TYPE <ul style="list-style-type: none"> <li>• <del>Vehicle Parking Reqmt: # spaces per unit of measurement</del></li> <li>• <del>Bicycle Parking Reqmt Requirement: # spaces per unit of measurement (% Required Spaces in Enclosed Facility / % Required Spaces in Fixed Facility)</del></li> </ul>									APPLICABLE USE LIMITATIONS
		U-SU-A U-SU-A2 U-SU-B U-SU-B2 U-SU-C U-SU-C2 U-SU-E U-SU-H	U-TU-B U-TU-B2 U-TU-C	U-RH-2.5 U-RH-3A	U-RX-3 U-RX-5	U-MX-2x U-MS-2x	U-MX-2 U-MS-2	U-MX-3	U-MS-3 U-MS-5	
Wholesale, Storage, Warehouse & Distribution	Automobile Towing Service Storage Yard*	NP	NP	NP	NP	NP	NP	NP	NP	
	Mini-storage Facility <ul style="list-style-type: none"> <li>• <del>Vehicle: 0.1 / 1,000 sf GFA</del></li> <li>• <del>Bicycle: No requirement</del></li> </ul>	NP	NP	NP	NP	NP	NP	L-ZP	NP	§11.5.23
	Vehicle Storage, Commercial*	NP	NP	NP	NP	NP	NP	NP	NP	
	Wholesale Trade or Storage, General	NP	NP	NP	NP	NP	NP	NP	NP	
	Wholesale Trade or Storage, Light <ul style="list-style-type: none"> <li>• <del>Vehicle: .5 / 1,000 sf GFA</del></li> <li>• <del>Bicycle: No requirement</del></li> </ul>	NP	NP	NP	NP	NP	NP	L-ZP/ ZPIN/ ZPSE	L-ZP/ZPIN/ ZPSE	§11.5.26
<b>AGRICULTURE PRIMARY USE CLASSIFICATION</b>										
Agriculture	Aquaculture*	NP	NP	NP	NP	NP	NP	NP	NP	
	Garden, Urban* <ul style="list-style-type: none"> <li>• <del>Vehicle: .5 / 1,000 sf GFA</del></li> <li>• <del>Bicycle: No requirement</del></li> </ul>	L-ZP	L-ZP	L-ZP	L-ZP	L-ZP	L-ZP	L-ZP	L-ZP	§11.6.2
	Husbandry, Animal*	NP	NP	NP	NP	NP	NP	NP	NP	
	Husbandry, Plant* <ul style="list-style-type: none"> <li>• <del>Vehicle: .5 / 1,000 sf GFA</del></li> <li>• <del>Bicycle: No requirement</del></li> </ul>	NP	NP	NP	L-ZP	L-ZP	L-ZP	L-ZP	L-ZP	§11.6.5

KEY: \* = Need Not be Enclosed P = Permitted Use without Limitations L = Permitted Use with Limitations NP = Not Permitted Use ZP = Zoning Permit Review  
ZPCIM = Subject to Zoning Permit Review with Community Information Meeting ZPIN = Subject to Zoning Permit Review with Informational Notice  
ZPSE = Subject to Zoning Permit with Special Exception Review When no ZP, ZPCIM, ZPIN, ZPSE listed = No Zoning Permit required

USE CATEGORY	SPECIFIC USE TYPE									APPLICABLE USE LIMITATIONS
	<ul style="list-style-type: none"> <li>• Vehicle Parking Reqmt: # spaces per unit of measurement</li> <li>• Bicycle Parking Reqmt Requirement: # spaces per unit of measurement (% Required Spaces in Enclosed Facility /% Required Spaces in Fixed Facility)</li> </ul>	U-SU-A								
		U-SU-A2								
		U-SU-B								
		U-SU-B2								
		U-SU-C								
		U-SU-C2	U-TU-B							
		U-SU-E	U-TU-B2	U-RH-2.5	U-RX-3	U-MX-2x	U-MX-2		U-MS-3	
		U-SU-H	U-TU-C	U-RH-3A	U-RX-5	U-MS-2x	U-MS-2	U-MX-3	U-MS-5	

ACCESSORY TO PRIMARY RESIDENTIAL USES USE CLASSIFICATION

USE CATEGORY	SPECIFIC USE TYPE	L - Applicable to all Zone Districts								APPLICABLE USE LIMITATIONS	
Accessory to Primary Residential Uses  (Parking is Not Required for Accessory Uses Unless Specifically Stated in this Table or in an Applicable Use Limitation)	Unlisted Accessory Uses									\$11.7	
	Accessory Dwelling Unit	L-ZP	L-ZP	L-ZP	L-ZP	L-ZP	L-ZP	L-ZP	L-ZP	\$11.7; §11.8.2	
	Domestic Employees Garden*	L	L	L	L	L	L	L	L	\$11.7; §11.8.3	
	Keeping of Household Animals*	L/L-ZPIN	L/L-ZPIN	L/L-ZPIN	L/L-ZPIN	L/L-ZPIN	L/L-ZPIN	L/L-ZPIN	L/L-ZPIN	\$11.7; §11.8.4	
	Keeping and Off-Street Parking of Vehicles, Motorcycles, Trailers & Recreational Vehicles*	L	L	L	L	L	L	L	L	\$11.7; §10.9	
	Kennel or Exercise Run*	L	L	L	L	L	L	L	L	\$11.7; §11.8.6	
	Limited Commercial Sales, Services Accessory to Multi-Unit Dwelling Use	NP	NP	NP	L-ZP	Not Applicable - See Permitted Primary Uses				\$11.7; §11.8.7	
	Outdoor Storage, Residential*	L	L	L	L	L	L	L	L	\$11.7; §11.8.8	
	Second Kitchen Accessory to Single Unit Dwelling Use	L-ZP	L-ZP	L-ZP	L-ZP	L-ZP	L-ZP	L-ZP	L-ZP	\$11.7; §11.8.9	
	Short-term Rental	L	L	L	L	L	L	L	L	\$11.7; §11.8.10	
	Vehicle Storage, Repair and Maintenance*	L	L	L	L	L	L	L	L	\$11.7; §10.9	
	Wind Energy Conversion Systems*	L-ZPIN/ZPSE	L-ZPIN/ZPSE	L-ZPIN/ZPSE	L-ZPIN/ZPSE	L-ZPIN/ZPSE	Not Applicable - See Permitted Primary Uses				\$11.7; §11.5.13
	Yard and/or Garage Sales*	L	L	L	L	L	L	L	L	\$11.7; §11.8.11	

KEY: \* = Need Not be Enclosed P = Permitted Use without Limitations L = Permitted Use with Limitations NP = Not Permitted Use ZP = Zoning Permit Review  
 ZPCIM = Subject to Zoning Permit Review with Community Information Meeting ZPIN = Subject to Zoning Permit Review with Informational Notice  
 ZPSE = Subject to Zoning Permit with Special Exception Review When no ZP, ZPCIM, ZPIN, ZPSE listed = No Zoning Permit required

USE CATEGORY	SPECIFIC USE TYPE									APPLICABLE USE LIMITATIONS
	<ul style="list-style-type: none"> <li>Vehicle Parking Reqmt: # spaces per unit of measurement</li> <li>Bicycle Parking Reqmt Requirement: # spaces per unit of measurement (% Required Spaces in Enclosed Facility / % Required Spaces in Fixed Facility)</li> </ul>	U-SU-A								
		U-SU-A2								
		U-SU-B								
		U-SU-B2								
		U-SU-C								
		U-SU-C2	U-TU-B							
		U-SU-E	U-TU-B2	U-RH-2.5	U-RX-3	U-MX-2x	U-MX-2		U-MS-3	
		U-SU-H	U-TU-C	U-RH-3A	U-RX-5	U-MS-2x	U-MS-2	U-MX-3	U-MS-5	

HOME OCCUPATIONS ACCESSORY TO PRIMARY RESIDENTIAL USES USE CLASSIFICATION

Home Occupations	Child Care Home, Large	L-ZP	L-ZP	L-ZP	L-ZP	L-ZP	L-ZP	L-ZP	L-ZP	\$11.9; §11.9.3
(Parking is Not Required for Home Occupations Unless Specifically Stated in this Table or in an Applicable Use Limitations)	All Other Types	L-ZP	L-ZP	L-ZP	L-ZP	L-ZP	L-ZP	L-ZP	L-ZP	\$11.9; §11.9.4
	Unlisted Home Occupations	L-ZPIN	L-ZPIN	L-ZPIN	L-ZPIN	L-ZPIN	L-ZPIN	L-ZPIN	L-ZPIN	\$11.9; §11.9.5

KEY: \* = Need Not be Enclosed P = Permitted Use without Limitations L = Permitted Use with Limitations NP = Not Permitted Use ZP = Zoning Permit Review  
 ZPCIM = Subject to Zoning Permit Review with Community Information Meeting ZPIN = Subject to Zoning Permit Review with Informational Notice  
 ZPSE = Subject to Zoning Permit with Special Exception Review When no ZP, ZPCIM, ZPIN, ZPSE listed = No Zoning Permit required

USE CATEGORY	SPECIFIC USE TYPE									APPLICABLE USE LIMITATIONS
	<ul style="list-style-type: none"> <li>• <del>Vehicle Parking Reqmt: # spaces per unit of measurement</del></li> <li>• <del>Bicycle Parking Reqmt Requirement: # spaces per unit of measurement (% Required Spaces in Enclosed Facility /% Required Spaces in Fixed Facility)</del></li> </ul>	U-SU-A								
		U-SU-A2								
		U-SU-B								
		U-SU-B2								
		U-SU-C								
		U-SU-C2	U-TU-B							
		U-SU-E	U-TU-B2	U-RH-2.5	U-RX-3	U-MX-2x	U-MX-2		U-MS-3	
		U-SU-H	U-TU-C	U-RH-3A	U-RX-5	U-MS-2x	U-MS-2	U-MX-3	U-MS-5	

**ACCESSORY TO PRIMARY NONRESIDENTIAL USES USE CLASSIFICATION**

USE CATEGORY	SPECIFIC USE TYPE	L - Applicable to all Zone Districts								APPLICABLE USE LIMITATIONS												
		U-SU-A	U-SU-A2	U-SU-B	U-SU-B2	U-SU-C	U-SU-C2	U-TU-B	U-TU-B2	U-TU-C	U-RH-2.5	U-RH-3A	U-RX-3	U-RX-5	U-MX-2x	U-MX-2	U-MX-3	U-MS-2	U-MS-3	U-MS-5		
Accessory to Primary Nonresidential Uses  (Parking is Not Required for Accessory Uses Unless Specifically Stated in this Table or in an Applicable Use Limitation)	Unlisted Accessory Uses																				\$11.7; \$11.10.1s	
	Amusement Devices Accessory to Eating/Drinking Establishments, College/University and Theater Uses	NP	NP	NP	NP	L-ZP	L-ZP	L-ZP	L-ZP	L-ZP											\$11.7; \$11.10.2	
	Automobile Rental Services Accessory to Certain Retail Uses*	NP	NP	NP	NP	Not Applicable - See permitted Primary Uses	NP	NP	Not Applicable - See permitted Primary Uses	Not Applicable - See Permitted Primary Uses											\$11.7; \$11.10.3	
	Book or gift store; media recording and production facilities accessory to public libraries, museums, places of religious assembly, colleges or universities	L	L	L	L	Not Applicable - See permitted Primary Uses	L	L	L	L												\$11.7; \$11.10.4
	Car Wash Bay Accessory to Automobile Services	NP	NP	NP	NP	L-ZP	NP	NP	L-ZP	NP												\$11.7 \$11.10.5
	College Accessory to a Place for Religious Assembly	L	L	L	L	Not Applicable - See permitted Primary Uses	L	Not Applicable - See permitted Primary Uses														\$11.7 \$11.10.6
	Conference Facilities Accessory to Hotel Use	NP	NP	NP	NP	L	NP	NP	L	L												\$11.7; \$11.10.7
	Drive Through Facility Accessory to Eating/Drinking Establishments and to Retail Sales, Service, and Repair Uses*	NP	NP	NP	NP	NP	NP	L-ZP	L-ZP	L-ZP												\$11.7; \$11.10.8
	Emergency Vehicle Access Point	NP	NP	NP	NP	NP	NP	NP	NP	NP												
	Garden*	L	L	L	L	L	L	L	L	L												\$11.7; \$11.10.10
	Keeping of Animals	L/L-ZPIN	L/L-ZPIN	L/L-ZPIN	L/L-ZPIN	L/L-ZPIN	L/L-ZPIN	L/L-ZP/L-ZPIN	L/L-ZP/L-ZPIN	L/L-ZP/L-ZPIN												\$11.7; \$11.10.11
	Limited Commercial Sales and Services	L	L	L	L	L	L	L	L	L												\$11.7; \$11.10.12
	Nonresidential Uses in Existing Business Structures In Residential Zones - Accessory Uses	L	L	L	L	Not Applicable - See permitted Primary Uses		Not Applicable														\$11.7; \$11.4.6
	Occasional Sales, Services Accessory to Primary Places of Religious Assembly or Primary Uses Operated by Nonprofit Organizations*	L	L	L	L	L	L	L	L	L												\$11.7; \$11.10.13
Outdoor Gathering Area*	L/L-ZP/L-ZPIN	L/L-ZP/L-ZPIN	L/L-ZP/L-ZPIN	L/L-ZP/L-ZPIN	L/L-ZP/L-ZPIN	L/L-ZP/L-ZPIN	L/L-ZP/L-ZPIN	L/L-ZP/L-ZPIN	L/L-ZP/L-ZPIN												\$11.7; \$11.10.14	

KEY: \* = Need Not be Enclosed P = Permitted Use without Limitations L = Permitted Use with Limitations NP = Not Permitted Use ZP = Zoning Permit Review  
 ZPCIM = Subject to Zoning Permit Review with Community Information Meeting ZPIN = Subject to Zoning Permit Review with Informational Notice  
 ZPSE = Subject to Zoning Permit with Special Exception Review When no ZP, ZPCIM, ZPIN, ZPSE listed = No Zoning Permit required

USE CATEGORY	SPECIFIC USE TYPE <ul style="list-style-type: none"> <li>• Vehicle Parking Reqmt: # spaces per unit of measurement</li> <li>• Bicycle Parking Reqmt Requirement: # spaces per unit of measurement (% Required Spaces in Enclosed Facility / % Required Spaces in Fixed Facility)</li> </ul>	SPECIFIC USE TYPE								APPLICABLE USE LIMITATIONS
		U-SU-A U-SU-A2 U-SU-B U-SU-B2 U-SU-C U-SU-C2 U-SU-E U-SU-H	U-TU-B U-TU-B2 U-TU-C	U-RH-2.5 U-RH-3A	U-RX-3 U-RX-5	U-MX-2x U-MS-2x	U-MX-2 U-MS-2	U-MX-3	U-MS-3 U-MS-5	
Accessory to Primary Nonresidential Uses  (Parking is Not Required for Accessory Uses Unless Specifically Stated in this Table or in an Applicable Use Limitation)	Outdoor Entertainment Accessory to an Eating/Drinking Establishment Use*	NP	NP	NP	L-ZPIN/ZPSE	NP	NP	L-ZPIN/ZPSE	L-ZPIN/ZPSE	§11.7; §11.10.15
	Outdoor Retail Sale and Display*	NP	NP	NP	L-ZP/ZPSE	NP	L-ZP/ZPSE	L-ZP/ZPSE	L-ZP/ZPSE	§11.7; §11.10.16
	Outdoor Storage, General*	NP	NP	NP	NP	NP	NP	NP	NP	
	Outdoor Storage, Limited*	NP	NP	NP	NP	L	L	L	L	§11.7; §11.10.18
	Rental or Sales of Adult Material Accessory to a Permitted Bookstore Retail Sales Use	NP	NP	NP	L	L	L	L	L	§11.7; §11.10.20
Retail Food Establishment, Mobile (Food Truck)*	L-ZP	L-ZP	L-ZP	L-ZP	L-ZP	L-ZP	L-ZP	L-ZP	L-ZP	§11.7; §11.10.19
<b>TEMPORARY USE CLASSIFICATION</b>										
Temporary Uses  (Parking is Not Required for Temporary Uses Unless Specifically Stated in this Table or in an Applicable Use Limitations)	Unlisted Temporary Uses	L - Applicable to all Zone Districts								§11.11.1
	Ambulance Service - Temporary	NP	NP	NP	L-ZP	Not Applicable - See Permitted Primary Uses				§11.11.2
	Amusement / Entertainment - Temporary*	NP	NP	NP	NP	NP	NP	NP	NP	
	Bazaar, Carnival, Circus or Special Event*	L-ZP	L-ZP	L-ZP	L-ZP	L-ZP	L-ZP	L-ZP	L-ZP	§11.11.4
	Building or yard for construction materials*	L-ZP	L-ZP	L-ZP	L-ZP	L-ZP	L-ZP	L-ZP	L-ZP	§11.11.5
	Concrete, Asphalt, and Rock Crushing Facility*	L-ZP	L-ZP	L-ZP	L-ZP	L-ZP	L-ZP	L-ZP	L-ZP	§11.11.6
	Fence for Demolition or Construction Work	L-ZP	L-ZP	L-ZP	L-ZP	L-ZP	L-ZP	L-ZP	L-ZP	§11.11.7
	Health Care Center	L-ZP	L-ZP	L-ZP	L-ZP	P-ZP	P-ZP	P-ZP	P-ZP	§11.11.8
	Noncommercial Concrete Batching Plant*	L-ZP	L-ZP	L-ZP	L-ZP	L-ZP	L-ZP	L-ZP	L-ZP	§11.11.9
	Outdoor Retail Sales - Pedestrian / Transit Mall*	NP	NP	NP	NP	NP	NP	NP	NP	
	Outdoor Retail Sales*	NP	NP	NP	L-ZP	L-ZP	L-ZP	L-ZP	NP	§11.11.11
	Outdoor Sales, Seasonal*	NP	NP	NP	L-ZPIN	L-ZP/ZPIN	L-ZP/ZPIN	L-ZP	L-ZP	§11.11.12
	Parking Lot Designated for a Special Event*	L-ZP	L-ZP	L-ZP	L-ZP	L-ZP	L-ZP	L-ZP	L-ZP	§11.11.13
	Retail Food Establishment, Mobile (Food Truck)*	NP	NP	NP	NP	NP	NP	NP	NP	
	Temporary Construction Office	L-ZP	L-ZP	L-ZP	L-ZP	L-ZP	L-ZP	L-ZP	L-ZP	§11.11.15
Temporary Office - Real Estate Sales	L-ZP	L-ZP	L-ZP	L-ZP	L-ZP	L-ZP	L-ZP	L-ZP	§11.11.16	
Temporary Managed Community*	L-ZPCIM	L-ZPCIM	L-ZPCIM	L-ZPCIM	L-ZPCIM	L-ZPCIM	L-ZPCIM	L-ZPCIM	§11.11.17	
Tent for Religious Services	NP	NP	NP	NP	NP	NP	NP	NP		

## SECTION 6.3.3 BUILDING FORM STANDARDS FOR PRIMARY STRUCTURES

### 6.3.3.1 Applicability

All development, except detached accessory structures, in all the General Urban Neighborhood Context zone districts

### 6.3.3.2 District Specific Standards Summary

The table below states the building forms allowed in each zone district. The table also summarizes the maximum number of structures allowed per Zone Lot, which is stated in more detail in Section 1.2.3.5, Number of Uses and Structures Allowed per Zone Lot.

See also Division 1.4, Building Form Standards - General Provisions, for additional standards related to initial assignment of building form standards to new and existing structures and for rules governing combining or changing building forms. Building Connectors between two detached structures shall follow the standards provided in Section 1.4.5, Applicable Building Form Standards for Detached Structures with Building Connector.

General Urban (G-) Neighborhood Context Zone Districts		Building Forms											
		Suburban House	Urban House	Duplex	Tandem House	Row House	Garden Court	Town House	Apartment	Drive Thru Services	Drive Thru Restaurant	General	Shopfront
<b>Max Number of Primary Structures Per Zone Lot</b>		1*	1*	1*	2	No Maximum							
<b>RESIDENTIAL ZONE DISTRICTS</b>													
Row House (RH)	G-RH-3		■	■		■							
Multi Unit (MU)	G-MU-3, -5		■	■			■	■	■				
	G-MU-8, -12, -20		■	■				■	■				
Residential Office (RO)	G-RO-3, -5		■	■				■	■				
<b>COMMERCIAL MIXED USE ZONE DISTRICTS</b>													
Residential Mixed Use (RX)	G-RX-3, -5							■				■	
Mixed Use (MX)	G-MX-3							■		□	□	■	
Main Street (MS)	G-MS-3, -5							■		□	□	■	

■ = Allowed □ = Allowed subject to geographic limitations \*See Section 1.2.3.5 for exceptions

### 6.3.3.3 District Specific Standards

#### A. Urban House

Not to Scale. Illustrative Only.

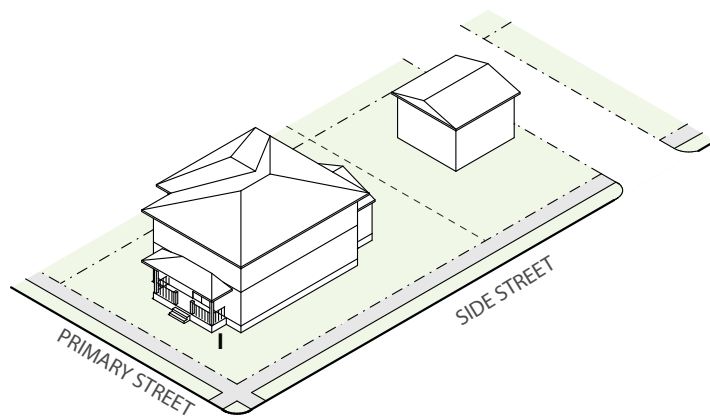
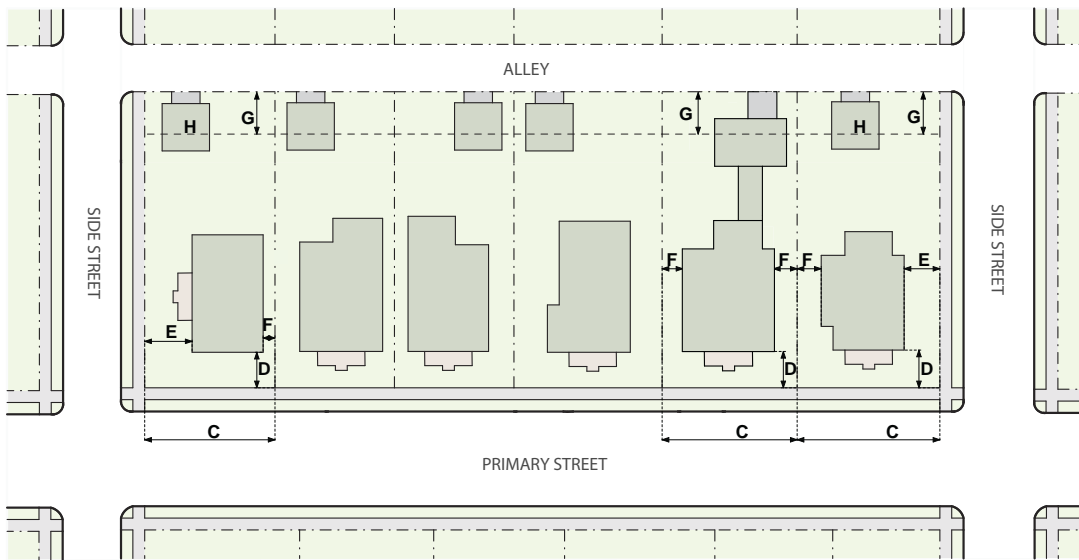
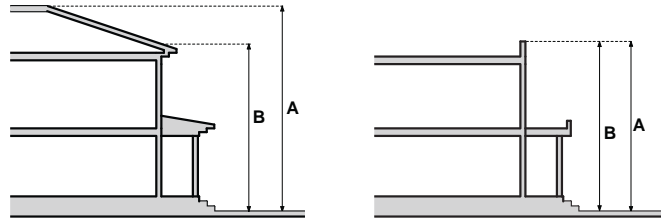

## URBAN HOUSE

<b>HEIGHT</b>		<b>G-RH-3</b>	<b>G-MU-3 G-RO-3</b>	<b>G-MU-5 G-RO-5</b>	<b>G-MU-8, -12, -20</b>
<b>A</b>	Stories (max)	see below	3	3	3
<b>A</b>	Feet (max)	see below	30'*	30'*	30'*
	Stories, front 80% / rear 20% of zone lot depth (max)	3/1	na	na	na
	Feet, front 80% / rear 20% of zone lot depth (max)	30'*/19'	na	na	na
<b>B</b>	Side Wall Height, for Pitched Roof, within 15' of Side Interior and Side Street (max)	25'	na	na	na
	Upper Story Setback, for Low-slope Roof, Above 25', Side Interior and Side Street (min)	15'	na	na	na

\*1' for every 5' increase in lot width over 50' up to a maximum height of 35'

<b>SITING</b>		<b>G-RH-3</b>	<b>G-MU-3 G-RO-3</b>	<b>G-MU-5 G-RO-5</b>	<b>G-MU-8, -12, -20</b>
<b>ZONE LOT</b>					
	Zone Lot Area (min)	3,000 sf	3,000 sf	3,000 sf	3,000 sf
<b>C</b>	Zone Lot Width (min)	25'	25'	25'	25'
<b>All G-RH, -MU, -RO</b>					
<b>SETBACKS AND BUILDING COVERAGE BY ZONE LOT WIDTH</b>		<b>30' or Less</b>	<b>Greater than 30' and up to 40'</b>	<b>Greater than 40' and less than 75'</b>	<b>75' or Greater</b>
<b>D</b>	Primary Street (min)	G-RH-3: Calculated per Sec. 13.1.5.9 G-MU-3 and G-RO-3: Calculated per Sec. 13.1.5.9, or 20', whichever is less G-MU-5, -8, -12, -20 and G-RO-5: 20'			
<b>E</b>	Side Street (min)	3'	5'	5'	5'
<b>F</b>	Side Interior (min)	3'	3' min one side/10' min combined	5'	7.5'
<b>G</b>	Rear, where Alley (public or private) abuts a Rear Zone Lot Line (min)	12'	12'	12'	12'
	Rear, where Alley (public or private) does not abut a Rear Zone Lot Line (min)	20'	20'	20'	20'
	Building Coverage per Zone Lot, including all accessory structures (max)	60%	45%	45%	40%
<b>PARKING BY ZONE LOT WIDTH</b>					
	Parking and Drive Lot Coverage in Primary Street Setback/Overall (max)	Maximum 16-foot wide measured parallel to the Primary Street zone lot line for any length, or 33% of the Zone Lot Area within the Primary Street setback, whichever is greater			
	Vehicle Access	From Alley; or Street access allowed when no Alley present. See Sec. 6.3.7.4.			
<b>H</b>	<b>DETACHED ACCESSORY STRUCTURES</b>	See Sec. 6.3.4			

<b>DESIGN ELEMENTS</b>		<b>All G-RH, -MU, -RO</b>
<b>BUILDING CONFIGURATION</b>		
Attached Garage Allowed	(1) Shall not be located closer to the minimum Primary Street Zone Lot Line than the Primary Street-facing Façade(s) comprising at least 65% of the total width of the primary structure enclosing the Primary Use. (2) May follow the General Detached Structure building form Side Street, Side Interior and Rear setbacks	
Primary Street Facing Attached Garage Door Width in front 50% of zone lot depth(max)	35% of the entire width of the Primary Street-facing façade of the primary structure or 16', whichever is greater	
<b>STREET LEVEL ACTIVATION</b>		
<b>I</b>	Pedestrian Access, Primary Street	Entry Feature
<b>USES</b>		
For Primary Structures constructed on or before April 27, 2017, all permitted Primary Uses shall be allowed within this building form; however, for Primary Structures constructed after April 27, 2017, Primary Uses shall be limited to Single Unit Dwelling and permitted Congregate Living, Residential Care, and Nonresidential uses. See Div. 6.4, Uses <b>and Required Minimum Parking</b> .		

See Sections 6.3.5 - 6.3.7 for Supplemental Design Standards, Design Standard Alternatives and Design Standard Exceptions



## DUPLEX

<b>HEIGHT</b>		<b>G-RH-3</b>	<b>G-MU-3 G-RO-3</b>	<b>G-MU-5 G-RO-5</b>	<b>G-MU-8, -12, -20</b>
<b>A</b>	Stories (max)	see below	3	3	3
<b>A</b>	Feet (max)	see below	30'*	30'*	30'*
	Stories, front 80% / rear 20% of zone lot depth (max)	3/1	na	na	na
	Feet, front 80% / rear 20% of zone lot depth (max)	30'*/19'	na	na	na
<b>B</b>	Side Wall Height, for Pitched Roof, within 15' of Side Interior and Side Street (max)	25'	na	na	na
	Upper Story Setback, for Low-slope Roof, Above 25': Side Street and Side Interior (min)	15'	na	na	na
*1' for every 5' increase in Zone Lot width over 50' up to a maximum height of 35'					
<b>SITING</b>		<b>G-RH-3</b>	<b>G-MU-3 G-RO-3</b>	<b>G-MU-5 G-RO-5</b>	<b>G-MU-8, -12, -20</b>
<b>ZONE LOT</b>					
	Zone Lot Area (min)	3,000 sf	3,000 sf	3,000 sf	3,000 sf
<b>C</b>	Zone Lot Width (min)	25'	25'	25'	25'
<b>SETBACKS AND BUILDING COVERAGE BY ZONE LOT WIDTH</b>		<b>All G-RH, -MU, -RO</b>			
		<b>30' or Less</b>	<b>Greater than 30' and up to 40'</b>	<b>Greater than 40' and less than 75'</b>	<b>75' or Greater</b>
<b>D</b>	Primary Street (min)	G-RH-3: Calculated per Sec. 13.1.5.9 G-MU-3 and G-RO-3: Calculated per Sec. 13.1.5.9, or 20', whichever is less G-MU-5, -8, -12, -20 and G-RO-5: 20'			
<b>E</b>	Side Street (min)	3'	5'	5'	5'
<b>F</b>	Side Interior (min)	3'	3' min one side/10' min combined	5'	7.5'
<b>G</b>	Rear, where Alley (public or private) abuts a Rear Zone Lot Line (min)	12'	12'	12'	12'
	Rear, where Alley (public or private) does not abut a Rear Zone Lot Line (min)	20'	20'	20'	20'
	Building Coverage per Zone Lot, including all accessory structures (max)	60%	45%	45%	40%
<b>PARKING BY ZONE LOT WIDTH</b>					
	Parking and Drive Lot Coverage in Primary Street Setback (max)	50%	50%	50%	50%
	Vehicle Access	From Alley; or Street access allowed when no Alley present See Sec. 6.3.7.4			
<b>H</b>	<b>DETACHED ACCESSORY STRUCTURES</b>	See Sec. 6.3.4			
<b>DESIGN ELEMENTS</b>		<b>All G-RH, -MU, -RO Districts</b>			
<b>BUILDING CONFIGURATION</b>					
	Attached Garage Allowed	(1) Shall not be located closer to the minimum Primary Street setback line than the Primary Street-facing Façade(s) comprising at least 65% of the total width of the primary structure enclosing the primary use. (2) May follow the General Detached Structure building form Side Street, Side Interior and Rear setbacks			
	Primary Street Facing Attached Garage Door Width in front 50% of zone lot depth(max)	35% of the entire width of the Primary Street-facing Façade of the primary structure or 16', whichever is greater			
<b>STREET LEVEL ACTIVATION</b>					
<b>I</b>	Pedestrian Access, Primary Street	Entry Feature			
<b>USES</b>		<b>All G-RH, -MU, -RO Districts</b>			
		For Primary Structures constructed on or before April 27, 2017, all permitted Primary Uses shall be allowed within this building form; however, for Primary Structures constructed after April 27, 2017, Primary Uses shall be limited to Two Unit Dwelling and permitted Congregate Living, Residential Care, and Nonresidential uses. See Div. 6.4, Uses <b>and Required Minimum Parking</b> .			

See Sections 6.3.5 - 6.3.7 for Supplemental Design Standards, Design Standard Alternatives and Design Standard Exceptions

## ROW HOUSE

### HEIGHT

G-RH-3

A	Stories (max)	see below
A	Feet (max)	see below
	Stories, front 80% / rear 20% of Zone Lot depth (max)	3/1
A	Feet, front 80% / rear 20% of Zone Lot depth (max)	30*/19'
B	Side Wall Height, for Pitched Roof, within 15' of Side Interior and Side Street (max)	25'
C	Upper Story Setback, for Low-slope Roof, Above 25': Side Street and Side Interior (min)	15'

\*1' for every 5' increase in Zone Lot width over 50' up to a maximum height of 35'

### SITING

G-RH-3

#### ZONE LOT

	Zone Lot Area (min)	6,000 sf
D	Zone Lot Width (min)	50'

#### SETBACKS

	Primary Street (min)	Calculated per Sec. 13.1.5.9
E	Side Street (min)	5'
F	Side Interior (min)	5'
	Rear, where Alley (public or private) abuts a Rear Zone Lot Line (min)	10'
	Rear, where Alley (public or private) does not abut a Rear Zone Lot Line (min)	20'

#### PARKING

	Surface Parking between building and Primary Street/Side Street	Not Allowed/Allowed
	Vehicle Access	From Alley; or Street access allowed when no Alley present
	<b>DETACHED ACCESSORY STRUCTURES</b>	See Sec. 6.3.4

### DESIGN ELEMENTS

G-RH-3

#### BUILDING CONFIGURATION

G	Dwelling Units Oriented to the Street	All Dwelling Units shall be Oriented to the Street
	Dwelling Unit Configuration	Structure shall only contain Side-by-Side Dwelling Units
H	Street-facing Garage Door Width per Primary Structure (max)	20'
	Attached Garage Allowed	May follow the General Detached Structure building form Side Street, Side Interior and Rear setbacks
I	Pedestrian Access	Each unit shall have a street-facing Entrance

### USES

G-RH-3

Primary Uses shall be limited to Multi Unit Dwelling (3+). See Div. 6.4, Uses ~~and Required Minimum Parking~~.

See Sections 6.3.5 - 6.3.7 for Supplemental Design Standards, Design Standard Alternatives and Design Standard Exceptions

## GARDEN COURT

<b>HEIGHT</b>		<b>G-MU-3</b>	<b>G-MU-5</b>
A	Stories (max)	3	3
A	Feet (max)	35'	35'
<b>SITING</b>		<b>G-MU-3</b>	<b>G-MU-5</b>
<b>ZONE LOT</b>			
	Zone Lot Area (min)	9,000 sf	9,000 sf
B	Zone Lot Width (min)	75'	75'
<b>SETBACKS</b>			
C	Primary Street (min)	Calculated per Sec. 13.1.5.9 or 20', whichever is less	10'
	Side Street (min)	7.5'	7.5'
D	Side Interior (min)	7.5'	7.5'
	Rear, where Alley (public or private) abuts a Rear Zone Lot Line (min)	10'	10'
	Rear, where Alley (public or private) does not abut a Rear Zone Lot Line (min)	20'	20'
E	Required Separation Between Primary Structures (min)	10'	10'
<b>PARKING</b>			
	Surface Parking between building and Primary Street/Side Street	Not Allowed/Not Allowed	
F	Off-Street Parking Area	Shall be Setback a minimum 50' from the Primary Street	
	Vehicle Access	From Alley; or Street access allowed when no Alley present	
G	<b>DETACHED ACCESSORY STRUCTURES</b>	See Sec. 6.3.4	
<b>DESIGN ELEMENTS</b>		<b>G-MU-3</b>	<b>G-MU-5</b>
<b>BUILDING CONFIGURATION</b>			
H	Street-Facing Courtyard Width (min)	30' or 33% of Zone Lot width, whichever is greater	
I	Street-Facing Courtyard Depth (min)	30'	
	Garden Court Design Standards	See Sec. 6.3.5.3	
	Attached Garage Allowed	May follow the General Detached Structure building form Side Street, Side Interior and Rear setbacks	
<b>STREET LEVEL ACTIVATION</b>			
J	Transparency, Primary Street (min)	30%	
	Transparency, Side Street (min)	25%	
K	Pedestrian Access	Each dwelling unit shall have a Street Level Entrance. A minimum of two dwelling units shall have a Dwelling Unit Entrance with Entry Feature facing the Primary Street and all other dwelling units shall have an Entrance that faces either the Primary Street or the interior Garden Court.	
<b>USES</b>		G-MU-3, G-MU-5	
		Primary Uses shall be limited to Two Unit Dwelling and Multi Unit Dwelling (3+). See Div. 6.4, Uses <del>and</del> <b>Required Minimum Parking</b> .	

See Sections 6.3.5 - 6.3.7 for Supplemental Design Standards, Design Standard Alternatives, and Design Standard Exceptions

## TOWN HOUSE (MULTI UNIT DISTRICTS)

<b>HEIGHT</b>		<b>G-RO-3 G-MU-3</b>	<b>G-RO-5 G-MU-5, -8, -12, -20</b>
A	Stories (max)	3	5
A	Feet (max)	35'	65'
<b>SITING</b>		<b>G-RO-3 G-MU-3</b>	<b>G-RO-5 G-MU-5, -8, -12, -20</b>
<b>ZONE LOT</b>			
	Zone Lot Area (min)	6,000 sf	6,000 sf
B	Zone Lot Width (min)	50'	50'
<b>REQUIRED BUILD-TO</b>			
C	Primary Street (min % within min/max)	70% 10'/15'	70% 10'/15'
	Exception from required Build-to	See Sec.13.1.5.7.D	
<b>SETBACKS</b>			
D	Primary Street (min)	Calculated per Sec. 13.1.5.9 or 20', whichever is less	10'
E	Side Street (min)	7.5'	7.5'
F	Side Interior, except Dwelling Units Oriented to the Street (min)	12.5'	12.5'
G	Side Interior, for Dwelling Units Oriented to the Street (min)	7.5'	7.5'
H	Side Interior, for Dwelling Units Oriented to the Street, adjacent to Protected District (min)	10'	10'
	Rear, where Alley (public or private) abuts a Rear Zone Lot Line (min)	10'	10'
	Rear, where Alley (public or private) does not abut a Rear Zone Lot Line (min)	20'	20'
<b>PARKING</b>			
	Surface Parking between building and Primary Street/Side Street	Not Allowed/Allowed	
	Vehicle Access	From Alley; or Street access allowed when no Alley present	
<b>DESIGN ELEMENTS</b>		<b>G-RO-3 G-MU-3</b>	<b>G-RO-5 G-MU-5, -8, -12, -20</b>
<b>BUILDING CONFIGURATION</b>			
I	Dwelling Units Oriented to the Street	Required if any portion of the Dwelling Unit is located within 30' of Primary Street Zone Lot Line or 20' of the Side Street Zone Lot Line.	
	Dwelling Unit Configuration	Structure may contain Side-by-Side Dwelling Units	
	Upper Story Setback Above 40', Side Interior (min)	na	G-MU-5: 15' G-RO-5, G-MU-8, -12, -20: na
	Upper Story Setback Above 51', Side Interior (min)	na	G-MU-5: na G-RO-5, G-MU-8, -12, -20: 15'
J	Upper Story Setback Above 27', adjacent to Protected District: Side Interior (min)	25'	25'
	Upper Story Setback Above 51', adjacent to Protected District: Side Interior (min)	na	40'
	Upper Story Setback Above 40', adjacent to Protected District: Rear, alley/Rear, no alley (min)	na	30'/40'
<b>STREET LEVEL ACTIVATION</b>			
K	Transparency, Primary Street (min)	40%	40%
	Transparency, Side Street (min)	25%	25%
L	Pedestrian Access	Each Dwelling Unit Oriented to the Street shall have Dwelling Unit Entrance with Entry Feature	
<b>USES</b>		<b>All G-MU and G-RO</b>	
Primary Uses shall be limited to Two Unit Dwelling and Multi-Unit Dwelling (3+) uses. See Div. 6.4, Uses <a href="#">and Required Minimum Parking</a> .			

See Sections 6.3.5 - 6.3.7 for Supplemental Design Standards, Design Standard Alternatives and Design Standard Exceptions

## TOWN HOUSE (MIXED USE DISTRICTS)

<b>HEIGHT</b>		<b>G-MX-3</b>	<b>G-RX-3</b>	<b>G-RX-5</b>	<b>G-MS-3</b>	<b>G-MS-5</b>
A	Stories (max)	3	3	5	3	5
A	Feet (min/max)	na/38'	na/38'	na/70'	na/38'	24'/70'

<b>SITING</b>		<b>G-MX-3</b>	<b>G-RX-3</b>	<b>G-RX-5</b>	<b>G-MS-3</b>	<b>G-MX-5</b>
<b>REQUIRED BUILD-TO</b>						
B	Primary Street (min % within min/max)	70%	75%	75%	75%	75%
		10'/15'	10'/15'	10'/15'	10'/15'	10'/15'
	Side Street (min % within min/max)	na	25%	25%	25%	25%
			7.5'/15'	7.5'/15'	7.5'/15'	7.5'/15'
<b>SETBACKS</b>						
C	Primary Street (min)	10'	10'	10'	10'	10'
D	Side Street (min)	7.5'	7.5'	7.5'	7.5'	7.5'
E	Side Interior (min)	5'	5'	5'	5'	5'
F	Side Interior, adjacent to Protected District (min)	10'	10'	10'	10'	10'
	Rear (min)	0'	0'	0'	0'	0'
	Rear, adjacent to Protected District, where Alley (public or private) abuts a Rear Zone Lot Line (min)	0'	0'	0'	0'	0'
	Rear, adjacent to Protected District, where Alley (public or private) does not abut a Rear Zone Lot Line	10'	10'	10'	10'	10'
<b>PARKING</b>						
	Surface Parking between building and Primary Street/Side Street	MX: Not Allowed/ Allowed		RX, MS: Not Allowed/Not Allowed		
	Vehicle Access	From Alley; or Street access allowed when no Alley present				

<b>DESIGN ELEMENTS</b>		<b>G-MX-3</b>	<b>G-RX-3</b>	<b>G-RX-5</b>	<b>G-MS-3</b>	<b>G-MS-5</b>
<b>BUILDING CONFIGURATION</b>						
G	Dwelling Units Oriented to the Street	Required if any portion of the Dwelling Unit is located within 20' of Primary Street Zone Lot Line or 20' of the Side Street Zone Lot Line. See Sec. 13.1.6.2.				
	Dwelling Unit Configuration	Structure may contain Side-by-Side Dwelling Units				
H	Upper Story Setback Above 27', adjacent to Protected District: Rear, alley/Rear, no alley and Side Interior (min)	15'/25'	15'/25'	20'/25'	15'/25'	20'/25'
	Upper Story Setback Above 51', adjacent to Protected District: Rear, alley/Rear, no alley and Side Interior (min)	na	na	35'/40'	na	35'/40'
<b>STREET LEVEL ACTIVATION</b>						
I	Transparency, Primary Street (min)	40%	40%	40%	40%	40%
	Transparency, Side Street (min)	25%	25%	25%	25%	25%
J	Pedestrian Access	Each Dwelling Unit Oriented to the Street shall have Dwelling Unit Entrance with Entry Feature				
<b>USES</b>						
	Street Level Active Uses (min % of Primary Street frontage meeting Build-To requirement)	40%	na	na	100%	100%
	Permitted Primary Uses	Primary Uses shall be limited to Two Unit Dwelling and Multi Unit Dwelling (3+) uses. See Div. 6.4, Uses and Required Minimum Parking.				

See Sections 6.3.5 - 6.3.7 for Supplemental Design Standards, Design Standard Alternatives and Design Standard Exceptions

## APARTMENT

		G-RO-3	G-MU-3	G-MU-5	G-RO-5	G-MU-8	G-MU-12	G-MU-20
<b>HEIGHT</b>								
A	Stories (max)	3		5	5	8	12	20
A	Feet (max)	40'		65'	65'	100'	140'	230'
	Stories/Feet, with incentives (max)	4/50'		7/90'	7/90'	12/140'	16/185'	30/340'
	Feet, within 175' of Protected District (max)	na		75'	75'	75'	75'	75'
		See Section 10.12.1, Height Incentives						
<b>SITING</b>								
<b>ZONE LOT</b>								
	Zone Lot Area (min)	6,000 sf		6,000 sf	6,000 sf	6,000 sf	6,000 sf	6,000 sf
	Zone Lot Width (min)	50'		50'	50'	50'	50'	50'
<b>REQUIRED BUILD-TO</b>								
B	Primary Street (min % within min/max)	60% 10'/20'		60% 10'/20'	60% 10'/20'	60% 10'/20'	60% 10'/20'	60% 10'/20'
	Exception from required Build-to	See Sec. 13.1.5.7.D, Required Build-to Exceptions						
<b>SETBACKS</b>								
C	Primary Street (min)	Calculated per Sec. 13.1.5.9 or 20'; whichever is less		10'	10'	10'	10'	10'
D	Side Street (min)	5'		5'	5'	5'	5'	5'
E	Side Interior (min)	7.5'		7.5'	7.5'	7.5'	7.5'	7.5'
	Side Interior, adjacent to Protected District (min)	10'		10'	10'	10'	10'	10'
F	Rear, where Alley (public or private) abuts a Rear Zone Lot Line (min)	10'		10'	10'	10'	10'	10'
	Rear, where Alley (public or private) does not abut a Rear Zone Lot Line (min)	20'		20'	20'	20'	20'	20'
<b>PARKING</b>								
	Surface Parking between Building and Primary Street/Side Street	Not Allowed/Allowed						
	Vehicle Access, all other permitted uses	Shall be determined as part of Site Development Plan Review						
<b>DESIGN ELEMENTS</b>								
<b>BUILDING CONFIGURATION</b>								
	Dwelling Unit Configuration	Structure may contain Side-by-Side Dwelling Units Residential Only Structure: Side-by-Side Dwelling Units shall not exceed 50% of the Structure's GFA						
	Street-facing Garage Door Width per Primary Structure (max)	20'		20'	20'	20'	20'	20'
	Upper Story Setback Above 40'; Side Interior (min)	na		15'	na	na	na	na
G	Upper Story Setback Above 51'; Side Interior (min)	na		na	15'	15'	15'	15'
H	Upper Story Setback Above 75'; Rear, alley/Rear, no alley and Side Interior (min)	na		na	na	20'/30'	20'/30'	20'/30'
I	Upper Story Setback Above 27'; adjacent to Protected District: Side Interior (min)	25'		25'	25'	25'	25'	25'
J	Upper Story Setback Above 51'; adjacent to Protected District: Side Interior (min)	na		40'	40'	40'	40'	40'
	Upper Story Setback Above 40'; adjacent to Protected District: Rear, alley/Rear, no alley (min)	na		30'/40'	30'/40'	30'/40'	30'/40'	30'/40'
<b>STREET LEVEL ACTIVATION</b>								
K	Transparency, Primary Street (min)	40%		40%	40%	40%	40%	40%
L	Transparency, Side Street (min)	25%		25%	25%	25%	25%	25%
M	Pedestrian Access, Primary Street	Entrance						
<b>USES</b>		All G-MU and G-RO						
		Primary Uses shall be limited to Multi Unit Dwelling (3+) and permitted Congregate Living, Residential Care, and Nonresidential uses. See Div. 6.4, Uses and Required Minimum Parking.						

See Sections 6.3.5 - 6.3.7 for Supplemental Design Standards, Design Standard Alternatives and Design Standard Exceptions

## DRIVE THRU SERVICES

HEIGHT	G-MX-3	G-MS-3, -5
Form is not permitted on Zone Lots within 1/4 mile of a Rail Transit Station Platform		
HEIGHT	G-MX-3	G-MS-3, -5
Stories (max)	3	3
Feet (max)	45'	45'
SITING	G-MX-3	G-MS-3, -5
<b>REQUIRED BUILD-TO</b>		
Primary Street (min % within min/max)*	50% 0'/15'	50% 0'/15'
Side Street (min % within min/max)*	50% 0'/15'	50% 0'/15'
<b>SETBACKS</b>		
Primary Street (min)	0'	0'
Side Street (min)	0'	0'
Side Interior (min)	0'	0'
Side Interior, adjacent to Protected District (min)	10'	10'
Rear (min)	0'	0'
Rear, adjacent to Protected District, where Alley (public or private) abuts a Rear Zone Lot Line (min)	0'	0'
Rear, adjacent to Protected District, where Alley (public or private) does not abut a Rear Zone Lot Line	10'	10'
<b>PARKING</b>		
Surface Parking between building and Primary Street/Side Street	Not Allowed/Allowed	Not Allowed/Not Allowed
Vehicle Access	Shall be determined as part of Site Development Plan Review	
DESIGN ELEMENTS	G-MX-3	G-MS-3, -5
<b>BUILDING CONFIGURATION</b>		
A *Canopy	Building shall be used to meet a portion of the Primary or Side Street Build-To. Canopy may be used to meet a portion of the Primary or Side Street Build-To	Building shall be used to meet a portion of the Primary and Side Street Build-To. Canopy may be used to meet a portion of the Primary and Side Street Build-To
B Screening Required	Garden Wall required within 0'/15' for 100% of the Primary and Side Street frontage, excluding access points and portions of building within 0'/15', following the standards of Sec. 10.5.4.4, Landscaping, Walls, and Screening	
Upper Story Setback Above 27', adjacent to Protected District: Rear, alley/Rear, no alley and Side Interior (min)	15'/25'	15'/25'
<b>STREET LEVEL ACTIVATION</b>		
C Transparency, Primary Street (min)	40%	60%
D Transparency, Side Street (min)	25%	25%
E Pedestrian Access, Primary Street	Entrance	Entrance
USES	G-MX-3	G-MS-3, -5
For Primary Structures constructed on or before June 25, 2010, all permitted Primary Uses shall be allowed within this building form; however, for Primary Structures constructed after June 25, 2010, Primary Uses shall be limited to Automobile Services, Light and/or Primary Use with Accessory Drive Thru Uses, excluding Eating & Drinking Establishments. See Div. 6.4, Uses <del>and</del> <b>Required Minimum Parking</b> .		

## DRIVE THRU RESTAURANT

<b>APPLICABILITY</b>		All G-MS, G-MX		
Form is not permitted on Zone Lots within 1/4 mile of the outer boundary of a Rail Transit Station Platform				
<b>HEIGHT</b>		All G-MX, G-MS		
Stories (max)		3		
Feet (min/max)		45'		
<b>SITING</b>		All G-MS	All G-MX Option A	All G-MX Option B
<b>REQUIRED BUILD-TO</b>				
Primary Street (min % within min/max)		Corner Lots: 50% 0'/5' All other: 75% 0'/5'	Corner Lots: 50% 0'/10' All other: 70% 0'/10'	Corner Lots: 50% 0'/35' All other: 70% 0'/10'
Side Street (min % within min/max)		50% 0'/5'	50% 0'/10'	50% 0'/18'
<b>SETBACKS</b>				
Primary Street (min)		0'	0'	0'
Side Street (min)		0'	0'	0'
Side Interior (min)		0'	0'	0'
Side Interior, adjacent to Protected District (min)		10'	10'	10'
Rear (min)		0'	0'	0'
Rear, adjacent to Protected District, where Alley (public or private) abuts a Rear Zone Lot Line (min)		0'	0'	0'
Rear, adjacent to Protected District, where Alley (public or private) does not abut a Rear Zone Lot Line		10'	10'	10'
<b>PARKING</b>				
Surface Parking between building and Primary Street/Side Street		Not Allowed/Not Allowed	Not Allowed/Not Allowed	Not Allowed/Not Allowed
<b>A</b>	Drive Thru Lane between building and Primary Street/Side Street	Not Allowed/Not Allowed	Not Allowed/Not Allowed	Allowed/Allowed
Drive Thru Lane Width (max)		na	na	12'
<b>B</b>	Drive Thru Lane Screening Required	na	na	Garden Wall, following the standards of Sec. 10.5.4.4
Vehicle Access		Shall be determined as part of Site Development Plan Review		
<b>DESIGN ELEMENTS</b>		All G-MS	All G-MX Option A	All G-MX Option B
<b>BUILDING CONFIGURATION</b>				
Upper Story Setback Above 27', adjacent to Protected District: Rear, alley/Rear, no alley and Side Interior (min)		15'/25'	15'/25'	15'/25'
<b>STREET LEVEL ACTIVATION</b>				
<b>C</b>	Transparency, Primary Street (min)	60%	40%	40%
<b>D</b>	Transparency, Side Street (min)	25%	25%	25%
<b>E</b>	Pedestrian Access, Primary Street	Entrance	Entrance	Entrance and Pedestrian Connection
<b>USES</b>		All G-MS, G-MX Zone Districts		
For Primary Structures constructed on or before June 25, 2010, all permitted Primary Uses shall be allowed within this building form; however, for Primary Structures constructed after June 25, 2010, Primary Uses shall be limited to an Eating & Drinking Establishment Primary Use with Accessory Drive Thru Use Only. See Div. 6.4 Uses, <del>and Required Minimum Parking</del>				



## GENERAL

### HEIGHT

G-MX-3

Stories (max)	3
Feet (max)	45'
Stories/Feet, with incentives (max)	4/55'
	See Section 10.12.1, Height Exceptions

### SITING

G-MX-3

#### REQUIRED BUILD-TO

A Primary Street (min build-to % within min/max range)	70% 0'/10'
--	------------

#### SETBACKS

Primary Street (min)	0'
Side Street (min)	0'
Side Interior (min)	0'
B Side Interior, adjacent to Protected District (min)	10'
Rear (min)	0'
Rear, adjacent to Protected District, where Alley (public or private) abuts a Rear Zone Lot Line (min)	0'
Rear, adjacent to Protected District, where Alley (public or private) does not abut a Rear Zone Lot Line	10'

#### PARKING

C Surface Parking between building and Primary Street	Not Allowed
C Surface Parking between building and Side Street	Allowed
D Surface Parking Screening	See Div. 10.5, Landscaping, Fences, Walls and Screening
Vehicle Access, all other permitted uses	Shall be determined as part of Site Development Plan Review

### DESIGN ELEMENTS

G-MX-3

#### BUILDING CONFIGURATION

Dwelling Unit Configuration	Structure may contain Side-by-Side Dwelling Units Residential Only Structure: Side-by-Side Dwelling Units shall not exceed 50% of the Structure's GFA
E Upper Story Setback Above 27', adjacent to Protected District: Rear, alley/Rear, no alley and Side Interior (min)	15'/25'

#### STREET LEVEL ACTIVATION

F Transparency, Primary Street (min)	40%
G Transparency, Side Street (min)	25%
H Pedestrian Access, Primary Street	Entrance

### USES

G-MX-3

Street Level Active Uses (min % of Primary Street frontage meeting Build-To requirement)	40%
Permitted Primary Uses	All permitted Primary Uses shall be allowed within this building form. See Div. 6.4, Uses, and Required Minimum Parking

See Sections 6.3.5 - 6.3.7 for Supplemental Design Standards, Design Standard Alternatives and Design Standard Exceptions

## SHOPFRONT

				G-MS-3		
<b>HEIGHT</b>		G-RX-3	G-RX-5	G-MX-3	G-MS-5	
Stories (max)		3	5	3	5	
A	Feet (min/max)	na/45'	na/70'	na/45'	24'/70'	
Stories/Feet, with incentives (max)		4/55'	7/95'	4/55'	7/95'	
Feet, within 175' of Protected District (max)		na	75'	na	75'	
		See Section 10.12.1, Height Incentives				
<b>SITING</b>		G-RX-3	G-RX-5	G-MX-3	G-MS-5	
<b>REQUIRED BUILD-TO</b>						
B	Primary Street (min build-to % within min/max range)	75% 0'/10'	75% 0'/10'	75% 0'/5' Residential Only Buildings: 0'/10'		
C	Side Street (min build-to % within min/max range)	na	na	25% 0'/5' Residential Only Buildings: 0'/10'		
<b>SETBACKS</b>						
Primary Street (min)		0'	0'	0'	0'	
Side Street (min)		0'	0'	0'	0'	
Side Interior (min)		0'	0'	0'	0'	
D	Side Interior, adjacent to Protected District (min)	10'	10'	10'	10'	
Rear (min)		0'	0'	0'	0'	
Rear, adjacent to Protected District, where Alley (public or private) abuts a Rear Zone Lot Line (min)		0'	0'	0'	0'	
Rear, adjacent to Protected District, where Alley (public or private) does not abut a Rear Zone Lot Line		10'	10'	10'	10'	
<b>PARKING</b>						
Surface Parking between building and Primary Street/Side Street		Not Allowed/Not Allowed				
E	Surface Parking Screening	See Div.10.5, Landscaping, Fences, Walls and Screening				
Vehicle Access, all other permitted uses		Shall be determined as part of Site Development Plan Review				
<b>DESIGN ELEMENTS</b>		G-RX-3	G-RX-5	G-MX-3	G-MS-5	
<b>BUILDING CONFIGURATION</b>						
Dwelling Unit Configuration		Structure may contain Side-by-Side Dwelling Units Residential Only Structure: Side-by-Side Dwelling Units shall not exceed 50% of the Structure's GFA				
F	Upper Story Setback Above 27', adjacent to Protected District: Rear, alley/Rear, no alley and Side Interior (min)	15'/25'	20'/25'	15'/25'	20'/25'	
G	Upper Story Setback Above 51', adjacent to Protected District: Rear, alley/Rear, no alley and Side Interior (min)	na	35'/40'	na	35'/40'	
<b>STREET LEVEL ACTIVATION</b>						
H	Transparency, Primary Street (min)	60% Residential Only Buildings: 40%				
I	Transparency, Side Street (min)	25%				
J	Pedestrian Access, Primary Street	Entrance				
<b>USES</b>		All G-RX Districts		G-MS-3, -5 and G-MX-3		
Street Level Active Uses (min % of Primary Street frontage meeting Build-To requirement)		na		100%		
Permitted Primary Uses		All permitted Primary Uses shall be allowed within this building form; however: (1) Second Story and Above: Residential or Lodging Accommodations Uses Only; and (2) Buildings with No Residential or Lodging Accommodation Uses: 10,000 sf GFA max		All permitted Primary Uses shall be allowed within this building form. See Div. 6.4, Uses, and Required Minimum Parking		

See Sections 6.3.5 - 6.3.7 for Supplemental Design Standards, Design Standard Alternatives and Design Standard Exceptions

BUILDING FEATURES	ZONE DISTRICTS	THE AGGREGATE SHALL NOT EXCEED 33-1/3 PERCENT OF THE AREA OF THE SUPPORTING ROOF	SHALL BE SET BACK FROM THE PERIMETER OF THE BUILDING A MINIMUM OF ONE FOOT HORIZONTALLY FOR EVERY ONE FOOT OF VERTICAL HEIGHT	MAY EXCEED MAXIMUM HEIGHT IN FEET BY:	MAY EXCEED MAXIMUM HEIGHT IN STORIES BY:	MAY PROJECT THROUGH THE BULK PLANE	MAY EXCEED UPPER STORY SETBACK HEIGHT BY
Open Structures	All 5-Story or greater G-MU, G-RO, G-RX, G-MS Zone Districts	Yes	Yes	28'	Not applicable	Not allowed	Not allowed
Parapet Wall or Safety Railing	All 3-Story or lower G-MU, G-RO, G-RX, G-MX, G-MS Zone Districts	No	No	Not allowed	Not applicable	Not allowed	4'
Parapet Wall or Safety Railing	All 5-Story or greater G- Zone Districts	No	No	Any distance	Not applicable	Not allowed	4'
Solar panels	All G- Zone Districts	No	No	Any distance	Not applicable	Any distance	Any distance
Evaporative coolers	All G- Zone Districts	No	Yes	Any distance	Not applicable	Any distance	Any distance
Accessory water tanks	All G-MX, G-MS Zone Districts	No	Yes	28'	Not applicable	Any distance	Any distance
Pedestrian bridge	All G- Zone Districts	Not applicable	Not applicable	28'	Any number	Any distance	Any distance

### 6.3.7.2 Setback Exceptions - Architectural, Site, Service & Utility Elements

#### A. Intent

To allow minor elements to encroach into a setback while maintaining an open and unobstructed minimum setback.

#### B. Standard

Except as specifically allowed below, Setbacks specified in the applicable Building Form tables shall be open and unobstructed.

#### C. Exceptions

The following Structures or portions of Structures are permitted to encroach into the Setbacks subject to the limitations in the tables below. No portion of a Structure that encroaches into the Setbacks shall extend into a required Setback beyond the maximum Setback encroachment distance specified in the tables below, as measured perpendicular to the respective Zone Lot line. Where more than one Setback encroachment is allowed for the same Structure or portion of a Structure, the permitted Setback encroachment distances shall not be cumulative. See "Height Exceptions" for encroachments related to Upper Story Setbacks.

##### 1. Architectural Elements

To allow for minor elements which add to the architectural character of buildings, while maintaining an open and unobstructed setback.

**2. Site Elements**

To allow for minor screening and parking elements while maintaining an open and unobstructed setback.

	ZONE DISTRICTS	BUILDING FORMS	PRIMARY STREET	SIDE STREET	SIDE INTERIOR	REAR
Fences and Walls	See Article 10, Div. 10.5 Landscaping, Fences, Walls and Screening					
Off-Street Parking Area	All G-RH, G-MU and G-RO	Urban House, Duplex	Any distance	Any distance	Any distance	Any distance
Intent: To allow off-street parking where it is <b>not less</b> impactful <b>due to the number of required parking spaces</b> .	<p>The diagram shows a plan view of a property with three buildings. The property is bounded by a Primary Street on the bottom, a Side Street on the right, and an Alley on the top. Vertical dashed lines indicate Side Setbacks for each building. Horizontal dashed lines indicate Rear and Primary Street Setbacks. Green shaded areas represent 'Allowed Encroachments' into the setbacks. The encroachments are shown as rectangular spaces between buildings and along the Primary Street setback line. The diagram is labeled 'Not to Scale. Illustrative Only.'</p>					

	ZONE DISTRICTS	BUILDING FORMS	PRIMARY STREET	SIDE STREET	SIDE INTERIOR	REAR
Off-Street Parking Area  When a Zone Lot contains two or more building forms with different permitted encroachments, the less restrictive standards shall apply. for the entire Zone Lot.	All G-RH, G-MU, G-RO, G-RX, G-MX and G-MS Zone Districts	Garden Court, Row House, and Apartment	Not allowed	Not allowed	Allowed within the rear 35% of the Zone Lot only	Any distance
		Town House	Not allowed	Not allowed* (*See exception below)	In the front 65% of the Zone Lot: 5' and at no point closer than 5' to the Zone Lot line. In the rear 35% of the Zone Lot: Any distance	Any distance
		General and Shopfront	Any distance	And distance	Any distance	Any distance
Intent: To restrict off-street parking where it is <b>more impactful due to the number of required parking spaces.</b>						
*Exception: The minimum 5' of back out space required in Div. 10.4 shall be permitted to encroach 2.5' when the encroachment is screened from the Side Street with a Garden Wall and 1 deciduous canopy tree or planting strip.						

## DIVISION 6.4 USES ~~AND REQUIRED MINIMUM PARKING~~

### SECTION 6.4.1 APPLICABILITY

- 6.4.1.1 This Division 6.4 sets forth the land uses permitted; ~~and the~~ required zoning procedures ~~and the required minimum parking~~ for all the General Urban Neighborhood Context zone districts.
- 6.4.1.2 Uses not listed are prohibited, unless the Zoning Administrator specifically permits the unlisted use according to Section 12.4.6, Code Interpretations and Determination of Unlisted Uses.
- 6.4.1.3 For number of primary and accessory uses allowed per Zone Lot, see Section 1.2.3.5, Number of Structures and Uses Allowed per Zone Lot.

### SECTION 6.4.2 ORGANIZATION - SUMMARY USE AND PARKING TABLE

#### 6.4.2.1 Organized by Primary, Accessory and Temporary Uses

The Use and Parking Table first presents all primary uses, then all accessory uses, and finally all temporary uses. Primary uses are arranged hierarchically within the table by use classification, category of primary uses, and then by specific use type. Accessory uses are organized by whether such use is accessory to a primary residential use or to a primary nonresidential use. Temporary uses are presented alphabetically ordered in the last division of the table.

#### 6.4.2.2 Primary Use Classifications, Categories & Specific Use Types

##### A. Primary Use Classifications

All primary land uses in the Use ~~and Parking~~ Table are organized into one of the following five general land use classifications:

1. Residential Uses
2. Civic, Public & Institutional Uses
3. Commercial Sales, Service & Repair Uses
4. Industrial, Manufacturing & Wholesale Uses
5. Agriculture

##### B. Primary Use Categories & Specific Use Types

Primary uses are further organized into use categories and specific use types listed under each general primary land use classification. The Use ~~and Parking~~ Table is organized into the above five general land use classifications, use categories and specific use types.

##### C. Classifications & Categories Are Mutually Exclusive

The general land use classifications and use categories listed in the Use ~~and Parking~~ Table are intended to be mutually exclusive; that is, a use classified into one use category, such as “lodging accommodations,” cannot be classified in a different use category, such as “congregate living,” unless otherwise expressly allowed by this Code.

### SECTION 6.4.3 EXPLANATION OF TABLE ABBREVIATIONS

#### 6.4.3.1 General Explanation of Table Cell Entries

In each of the table cells, the entry will indicate first whether use limitations apply to the specific use, and then separated by a hyphen, the type of zoning review required prior to establishment of the use under this Code. For example, as described in more detail below, a cell entry “L-ZPIN” means, first, the use is subject to use limitations (the “L”), and, second, that the use is subject to zoning permit review with information notice (the “ZPIN”) prior to its establishment.

### 6.4.3.2 Permitted, Limited, Not Permitted

#### A. Permitted Use - No Use Limitations Apply (“P”)

A “P” in a table cell indicates that the use is permitted in the respective zone district, and is not subject to use limitations.

#### B. Permitted Use - Subject to Use Limitations (“L”)

“L” in a table cell indicates the use is permitted in the zone district subject to compliance with the use limitations referenced in the last column of the use table (“Applicable Use Limitations”).

#### C. Uses Not Permitted (“NP”)

“NP” in a table cell indicates that the use is not permitted in the specific zone district.

### 6.4.3.3 Zoning Procedure

#### A. Use Subject to Zoning Permit Review (“ZP”)

“ZP” in a table cell indicates that the use is permitted in the respective zone district only if reviewed and approved according to the requirements in Section 12.4.1, Zoning Permit Review.

#### B. Use Subject to Zoning Permit Review with Informational Notice (“ZPIN”)

“ZPIN” in a table cell indicates that the use is permitted in the respective zone district only if reviewed and approved according to the public notice and procedural requirements in Section 12.4.2, Zoning Permit Review with Informational Notice. Such uses shall comply with any applicable use limitations noted in the last column of the use table (“Applicable Use Limitations”), as well as the review criteria stated in Section 12.4.2, Zoning Permit Review with Informational Notice.

#### C. Use Subject to Zoning Permit Review with Community Information Meeting (“ZPCIM”)

“ZPCIM” in a table cell indicates that the use is permitted in the respective zone district only if reviewed and approved according to the public notice and procedural requirements in Section 12.4.1, Zoning Permit Review. Prior to formal application, an applicant shall schedule a community information meeting and provide public notice of the community information meeting according to Section 12.3.4.6, Community Information Meeting.

#### D. Use Subject to Zoning Permit with Special Exception Review (“ZPSE”)

“ZPSE” in a table cell indicates that use is generally appropriate in the neighborhood context and zone district, yet may have the potential for limited impacts on adjacent properties or on the established character of the neighborhood context or zone district. “ZPSE” uses are subject to a Board of Adjustments public hearing according to Section 12.4.9, Zoning Permit with Special Exception Review, which grants the Board of Adjustment the authority to impose conditions on the specified use to mitigate any potential impacts. Such uses shall comply with any applicable use limitations noted in the last column of the use table (“Applicable Use Limitations”), as well as the review criteria stated in Section 12.4.9, Zoning Permit with Special Exception Review.

#### E. Uses Where More Than One Zoning Procedure Is Indicated

Where a table cell shows more than one zoning procedure applies to a use, for example “L-ZP/ZPIN”, the referenced use limitation (last table column) will indicate which zoning procedure applies in a specific case. For example, a table cell may indicate “L-ZPIN/ZPSE” for a use. This means that the ZPIN zoning procedure will apply, unless the applicable use limitation specifies the ZPSE zoning procedure is triggered (e.g., by proximity to a Protected District).

### 6.4.3.4 Enclosure of Uses

All primary, accessory and temporary uses must be established, operated and maintained within a Completely Enclosed Structure, unless otherwise specifically allowed by this Code. The Use ~~and~~ **Parking** Tables in Articles 3-9 indicate when a use may be established, operated or maintained outside a Completely Enclosed Structure by including an asterisk “\*” next to the specific use type. For example, the asterisk following the “Telecommunication Tower\*” use type in the tables indicates that a telecommunication tower land use need not be enclosed.

## SECTION 6.4.4 DISTRICT SPECIFIC STANDARDS

KEY: \* = Need Not be Enclosed P = Permitted Use without Limitations L = Permitted Use with Limitations NP = Not Permitted Use ZP = Zoning Permit Review  
ZPCIM = Subject to Zoning Permit Review with Community Information Meeting ZPIN = Subject to Zoning Permit Review with Informational Notice  
ZPSE = Subject to Zoning Permit with Special Exception Review When no ZP, ZPCIM, ZPIN, ZPSE listed = No Zoning Permit required

USE CATEGORY	SPECIFIC USE TYPE <del>• Vehicle Parking Reqmt: # spaces per unit of measurement</del> <del>• Bicycle Parking Reqmt Requirement: # spaces per unit of measurement (% Required Spaces in Enclosed Facility / % Required Spaces in Fixed Facility)</del>								APPLICABLE USE LIMITATIONS	
		G-RH-3	G-MU-5 G-MU-8	G-MU-3 G-MU-12 G-MU-20	G-RO-3 G-RO-5	G-RX-3 G-RX-5	G-MX-3	G-MS-3 G-MS-5		
<b>RESIDENTIAL PRIMARY USE CLASSIFICATION</b>										
Household Living	Dwelling, Single Unit <del>• No Parking Requirements</del>	L-ZP	L-ZP	L-ZP	L-ZP	L-ZP	L-ZP	L-ZP	L-ZP	\$11.2.7
	Dwelling, Two Unit <del>• Vehicle: 1/unit</del> <del>• Bicycle: No requirement</del>	L-ZP	L-ZP	L-ZP	L-ZP	L-ZP	L-ZP	L-ZP	L-ZP	\$11.2.2; \$11.2.7
	Dwelling, Multi-Unit <del>• Vehicle: 1/unit</del> <del>• Bicycle: 1/4 units (80/20)</del>	L-ZP	L-ZP	L-ZP	L-ZP	L-ZP	L-ZP	L-ZP	L-ZP	\$11.2.3; \$11.2.7
	Dwelling, Live / Work <del>• Vehicle: 1/unit</del> <del>• Bicycle: 1/4 units (80/20)</del>	NP	NP	NP	L-ZP	L-ZP	L-ZP	L-ZP	L-ZP	\$11.2.4; \$11.2.7
	Manufactured Home Community	NP	NP	NP	NP	NP	NP	NP	NP	
Residential Care	Residential Care, Type 1 <del>• Vehicle: .5/1,000 sf GFA</del> <del>• Bicycle: No requirement</del>	L/L-ZP	L/L-ZP	L/L-ZP	L/L-ZP	L/L-ZP	L/L-ZP	L/L-ZP	L/L-ZP	\$11.2.8; \$11.2.9
	Residential Care, Type 2 <del>• Vehicle: .5/1,000 sf GFA</del> <del>• Bicycle: No requirement</del>	L-ZPCIM	L-ZP	L-ZP	L-ZP	L-ZP	L-ZP	L-ZP	L-ZP	\$11.2.8; \$11.2.10
	Residential Care, Type 3 <del>• Vehicle: .5/1,000 sf GFA</del> <del>• Bicycle: No requirement</del>	NP	L-ZPCIM	L-ZPCIM	L-ZPCIM	L-ZPCIM	L-ZPCIM	L-ZPCIM	L-ZPCIM	\$11.2.8; \$11.2.11
	Residential Care, Type 4 <del>• Vehicle: .5/1,000 sf GFA</del> <del>• Bicycle: No requirement</del>	NP	G-MU-3, -5: NP G-MU-8: L-ZPCIM	L-ZPCIM	L-ZPCIM	L-ZPCIM	L-ZPCIM	L-ZPCIM	L-ZPCIM	\$11.2.8; \$11.2.12
Congregate Living	All Types <del>• Vehicle: 1/1,000 sf GFA</del> <del>• Bicycle: 1/20,000 sf GFA</del>	P-ZP	P-ZP	P-ZP	P-ZP	P-ZP	P-ZP	P-ZP	P-ZP	
<b>CIVIC, PUBLIC &amp; INSTITUTIONAL PRIMARY USE CLASSIFICATION</b>										
Basic Utilities	Utility, Major Impact* <del>• Vehicle: .5/1,000 sf GFA</del> <del>• Bicycle: No requirement</del>	L-ZPSE	L-ZPSE	L-ZPSE	L-ZPSE	L-ZPSE	L-ZPSE	L-ZPSE	L-ZPSE	\$ 11.3.1
	Utility, Minor Impact* <del>• Vehicle: .5/1,000 sf GFA</del> <del>• Bicycle: No requirement</del>	L-ZP	L-ZP	L-ZP	L-ZP	L-ZP	L-ZP	L-ZP	L-ZP	\$ 11.3.2



KEY: \* = Need Not be Enclosed P = Permitted Use without Limitations L = Permitted Use with Limitations NP = Not Permitted Use ZP = Zoning Permit Review  
 ZPCIM = Subject to Zoning Permit Review with Community Information Meeting ZPIN = Subject to Zoning Permit Review with Informational Notice  
 ZPSE = Subject to Zoning Permit with Special Exception Review When no ZP, ZPCIM, ZPIN, ZPSE listed = No Zoning Permit required

USE CATEGORY	SPECIFIC USE TYPE <ul style="list-style-type: none"> <li>• <del>Vehicle Parking Reqmt: # spaces per unit of measurement</del></li> <li>• <del>Bicycle Parking Reqmt Requirement: # spaces per unit of measurement (% Required Spaces in Enclosed Facility / % Required Spaces in Fixed Facility)</del></li> </ul>								APPLICABLE USE LIMITATIONS	
		G-RH-3	G-MU-3 G-MU-5 G-MU-8	G-MU-12 G-MU-20	G-RO-3 G-RO-5	G-RX-3 G-RX-5	G-MX-3	G-MS-3 G-MS-5		
Community/ Public Services	Community Center* <ul style="list-style-type: none"> <li>• <del>Vehicle: .5 / 1,000 sf GFA</del></li> <li>• <del>Bicycle: 1 / 10,000 sf GFA (0/100)</del></li> </ul>	L-ZP	L-ZP	L-ZP	L-ZP	L-ZP	L-ZP	L-ZP	L-ZP	§ 11.3.3
	Day Care Center <ul style="list-style-type: none"> <li>• <del>Vehicle: 1 / 1,000 sf GFA</del></li> <li>• <del>Bicycle: 1 / 10,000 sf GFA (0/100)</del></li> </ul>	P-ZP	P-ZP	P-ZP	P-ZP	P-ZP	P-ZP	P-ZP	P-ZP	
	Postal Facility, Neighborhood <ul style="list-style-type: none"> <li>• <del>Vehicle: 1.875 / 1,000 sf GFA</del></li> <li>• <del>Bicycle: 1 / 10,000 sf GFA (20/80)</del></li> </ul>	P-ZP	NP	NP	P-ZP	P-ZP	P-ZP	P-ZP	P-ZP	
	Postal Processing Center <ul style="list-style-type: none"> <li>• <del>Vehicle: 1 / 1,000 sf GFA</del></li> <li>• <del>Bicycle: 1 / 10,000 sf GFA (20/80)</del></li> </ul>	NP	NP	NP	NP	P-ZP	P-ZP	P-ZP	P-ZP	
	Public Safety Facility <ul style="list-style-type: none"> <li>• <del>Vehicle: 1 / 1,000 sf GFA</del></li> <li>• <del>Bicycle: 1 / 10,000 sf GFA (0/100)</del></li> </ul>	L-ZP	L-ZP	L-ZP	L-ZP	L-ZP	P-ZP	P-ZP	P-ZP	§ 11.3.5
	Hospital	NP	NP	NP	NP	NP	NP	NP	NP	
	Correctional Institution	NP	NP	NP	NP	NP	NP	NP	NP	
Cultural/ Special Purpose/ Public Parks & Open Space	Cemetery*	NP	NP	NP	NP	NP	NP	NP	NP	
	Library <ul style="list-style-type: none"> <li>• <del>Vehicle: 1 / 1,000 sf GFA</del></li> <li>• <del>Bicycle: 1 / 10,000 sf GFA (0/100)</del></li> </ul>	P-ZP	P-ZP	P-ZP	P-ZP	P-ZP	P-ZP	P-ZP	P-ZP	
	Museum <ul style="list-style-type: none"> <li>• <del>Vehicle: 1 / 1,000 sf GFA</del></li> <li>• <del>Bicycle: 1 / 10,000 sf GFA (0/100)</del></li> </ul>	NP	NP	NP	NP	P-ZP	P-ZP	P-ZP	P-ZP	
	City Park*	NP	NP	NP	NP	NP	NP	NP	NP	
	Open Space - Conservation* <ul style="list-style-type: none"> <li>• <del>No Parking Requirements</del></li> </ul>	P-ZP	P-ZP	P-ZP	P-ZP	P-ZP	P-ZP	P-ZP	P-ZP	
Education	Elementary or Secondary School <ul style="list-style-type: none"> <li>• <del>Vehicle: 1 / 1,000 sf GFA</del></li> <li>• <del>Bicycle: 1 / 10,000 sf GFA (0/100)</del></li> </ul>	L-ZP	L-ZP	L-ZP	L-ZP	L-ZP	L-ZP	L-ZP	L-ZP	§ 11.3.8
Education	University or College <ul style="list-style-type: none"> <li>• <del>Vehicle: 1 / 1,000 sf GFA</del></li> <li>• <del>Bicycle: 1 / 10,000 sf GFA (0/100)</del></li> </ul>	NP	L-ZP	L-ZP	NP	L-ZP	L-ZP	L-ZP	L-ZP	§ 11.3.8 ; § 11.3.9
	Vocational or Professional School <ul style="list-style-type: none"> <li>• <del>Vehicle: 1 / 1,000 sf GFA</del></li> <li>• <del>Bicycle: 1 / 10,000 sf GFA (0/100)</del></li> </ul>	NP	NP	NP	NP	L-ZP	L-ZP	L-ZP	L-ZP	§ 11.3.8
Public and Religious Assembly	All Types <ul style="list-style-type: none"> <li>• <del>Vehicle: .5 / 1,000 sf GFA</del></li> <li>• <del>Bicycle: 1 / 10,000 sf GFA (0/100)</del></li> </ul>	L-ZP	L-ZP	L-ZP	L-ZP	L-ZP	P-ZP	P-ZP	P-ZP	§ 11.3.10
<b>COMMERCIAL SALES, SERVICES, &amp; REPAIR PRIMARY USE CLASSIFICATION</b>										
Adult Business	All Types	NP	NP	NP	NP	NP	NP	NP	NP	See Sec. 9.4.4, Use Overlay Districts, for adult business use allowance in the UO-1 District.

KEY: \* = Need Not be Enclosed P = Permitted Use without Limitations L = Permitted Use with Limitations NP = Not Permitted Use ZP = Zoning Permit Review  
ZPCIM = Subject to Zoning Permit Review with Community Information Meeting ZPIN = Subject to Zoning Permit Review with Informational Notice  
ZPSE = Subject to Zoning Permit with Special Exception Review When no ZP, ZPCIM, ZPIN, ZPSE listed = No Zoning Permit required

USE CATEGORY	SPECIFIC USE TYPE • <del>Vehicle Parking Reqmt: # spaces per unit of measurement</del> • <del>Bicycle Parking Reqmt Requirement: # spaces per unit of measurement (% Required Spaces in Enclosed Facility / % Required Spaces in Fixed Facility)</del>								APPLICABLE USE LIMITATIONS
		G-RH-3	G-MU-3 G-MU-5 G-MU-8	G-MU-12 G-MU-20	G-RO-3 G-RO-5	G-RX-3 G-RX-5	G-MX-3	G-MS-3 G-MS-5	
Arts, Recreation and Entertainment	Arts, Recreation and Entertainment Services, Indoor • <del>Vehicle - Artist Studio: 0.3/1000 sf GFA</del> • <del>Vehicle - All Others: 1.875/1,000 sf GFA</del> • <del>Bicycle: /10,000 sf GFA (20/80)</del>	NP	NP	NP	L-ZP	P-ZP	P-ZP	P-ZP	§ 11.4.2
	Arts, Recreation and Entertainment Services, Outdoor* • <del>Vehicle: 1.875/1,000 sf GFA</del> • <del>Bicycle: 1/10,000 sf GFA (20/80)</del>	NP	NP	NP	NP	L-ZPSE	L-ZPSE	L-ZPSE	§ 11.4.3
	Event Space with Alternate Parking and Loading* • <del>Vehicle: No requirement</del> • <del>Bicycle: No requirement</del>	NP	NP	NP	NP	NP	NP	NP	
	Sports and/or Entertainment Arena or Stadium*	NP	NP	NP	NP	NP	NP	NP	
Nonresidential Uses in Existing Business Structures In Residential Zones <del>(All Uses Shall Be Parked According to the Parking Requirement Stated in this Use Table for the Specific Nonresidential Use)</del>		L-ZP	L-ZP	L-ZP	L-ZP	Not Applicable			§ 11.4.6
Parking of Vehicles	Parking, Garage • <del>No Parking Requirements</del>	NP	P-ZP	P-ZP	P-ZP	P-ZP	P-ZP	P-ZP	
	Parking, Surface* • <del>No Parking Requirements</del>	L-ZP	L-ZP	L-ZP	L-ZP	NP	NP	NP	§ 11.4.8
Eating & Drinking Establishments	All Types • <del>Vehicle - MS only: 2/1,000 sf GFA</del> • <del>Vehicle: 3.75/1,000 sf GFA</del> • <del>Bicycle: 1/3,000 sf GFA (0/100)</del>	NP	NP	NP	NP	P-ZP	P-ZP	P-ZP	§ 11.4.9
Lodging Accommodations	Bed and Breakfast Lodging • <del>Vehicle: 1/guest room or unit</del> • <del>Bicycle: 1/10,000 sf GFA (60/40)</del>	NP	NP	NP	P-ZP	P-ZP	P-ZP	P-ZP	
	Lodging Accommodations, All Others • <del>Vehicle: 1/guest room or unit</del> • <del>Bicycle: 1/10,000 sf GFA (60/40)</del>	NP	NP	NP	NP	P-ZP	P-ZP	P-ZP	
Office	Dental / Medical Office or Clinic • <del>Vehicle: 1.875/1,000 sf GFA</del> • <del>Bicycle: 1/10,000 sf GFA (60/40)</del>	NP	NP	NP	L-ZPIN	L-ZP	L-ZP	L-ZP	§ 11.4.10
	Office, All Others • <del>Vehicle: 1.875/1,000 sf GFA</del> • <del>Bicycle: 1/10,000 sf GFA (60/40)</del>	NP	NP	NP	P-ZP	P-ZP	P-ZP	P-ZP	

KEY: \* = Need Not be Enclosed P = Permitted Use without Limitations L = Permitted Use with Limitations NP = Not Permitted Use ZP = Zoning Permit Review  
ZPCIM = Subject to Zoning Permit Review with Community Information Meeting ZPIN = Subject to Zoning Permit Review with Informational Notice  
ZPSE = Subject to Zoning Permit with Special Exception Review When no ZP, ZPCIM, ZPIN, ZPSE listed = No Zoning Permit required

USE CATEGORY	SPECIFIC USE TYPE <del>• Vehicle Parking Reqmt: # spaces per unit of measurement</del> <del>• Bicycle Parking Reqmt Requirement: # spaces per unit of measurement (% Required Spaces in Enclosed Facility / % Required Spaces in Fixed Facility)</del>								APPLICABLE USE LIMITATIONS
		G-RH-3	G-MU-3 G-MU-5 G-MU-8	G-MU-12 G-MU-20	G-RO-3 G-RO-5	G-RX-3 G-RX-5	G-MX-3	G-MS-3 G-MS-5	
Retail Sales, Service & Repair (Not Including Vehicle or Equipment Sales, Service & Repair)	Animal Sales and Services, Household Pets Only <del>• Vehicle: 1.875/1,000 sf GFA</del> <del>• Bicycle: 1/10,000 sf GFA (20/80)</del>	NP	NP	NP	NP	L-ZP	L-ZP	L-ZP	§ 11.4.12
	Animal Sales and Services, All Others	NP	NP	NP	NP	NP	NP	NP	
	Food Sales or Market <del>• Vehicle: 1.875/1,000 sf GFA</del> <del>• Bicycle: 1/10,000 sf GFA (20/80)</del>	NP	NP	NP	NP	L-ZP	P-ZP	P-ZP	§ 11.4.14
	Pawn Shop	NP	NP	NP	NP	NP	NP	NP	
	Retail Sales, Service & Repair -- Outdoor*	NP	NP	NP	NP	NP	NP	NP	
	Retail Sales, Service & Repair - Firearms Sales <del>• Vehicle: 1.875/1,000 sf GFA</del> <del>• Bicycle: 1/10,000 sf GFA (20/80)</del>	NP	NP	NP	NP	NP	NP	P-ZP	
Retail Sales, Service & Repair, All Others <del>• Vehicle: 1.875/1,000 sf GFA</del> <del>• Bicycle: 1/10,000 sf GFA (20/80)</del>	NP	NP	NP	NP	P-ZP	P-ZP	P-ZP		
Vehicle / Equipment Sales, Rentals, Service & Repair	Automobile Emissions Inspection Facility <del>• Vehicle: .5/1,000 sf GFA</del> <del>• Bicycle: No requirement</del>	NP	NP	NP	NP	NP	P-ZP	P-ZP	
	Automobile Services, Light <del>• Vehicle: .5/1,000 sf GFA</del> <del>• Bicycle: No requirement</del>	NP	NP	NP	NP	NP	L-ZP	L-ZP	§ 11.4.18; § 11.4.19
	Automobile Services, Heavy <del>Vehicle: .5/1,000 sf GFA</del> <del>Bicycle: No requirement</del>	NP	NP	NP	NP	NP	NP	L-ZP/ZPSE	§ 11.4.18; § 11.4.20
	Automobile / Motorcycle / Light Truck Sales, Rentals, Leasing; Pawn Lot or Vehicle Auctioneer* <del>• Vehicle: .5/1,000 sf GFA</del> <del>• Bicycle: No requirement</del>	NP	NP	NP	NP	L-ZP	L-ZP	L-ZP	§ 11.4.21
	Heavy Vehicle/ Equipment Sales, Rentals & Service*	NP	NP	NP	NP	NP	NP	NP	

KEY: \* = Need Not be Enclosed P = Permitted Use without Limitations L = Permitted Use with Limitations NP = Not Permitted Use ZP = Zoning Permit Review  
 ZPCIM = Subject to Zoning Permit Review with Community Information Meeting ZPIN = Subject to Zoning Permit Review with Informational Notice  
 ZPSE = Subject to Zoning Permit with Special Exception Review When no ZP, ZPCIM, ZPIN, ZPSE listed = No Zoning Permit required

USE CATEGORY	SPECIFIC USE TYPE <ul style="list-style-type: none"> <li>• <del>Vehicle Parking Reqmt: # spaces per unit of measurement</del></li> <li>• <del>Bicycle Parking Reqmt Requirement: # spaces per unit of measurement (% Required Spaces in Enclosed Facility / % Required Spaces in Fixed Facility)</del></li> </ul>								APPLICABLE USE LIMITATIONS	
		G-RH-3	G-MU-8	G-MU-12	G-MU-20	G-RO-3 G-RO-5	G-RX-3 G-RX-5	G-MX-3		G-MS-3 G-MS-5
<b>INDUSTRIAL, MANUFACTURING &amp; WHOLESALE PRIMARY USE CLASSIFICATION</b>										
Communications and Information	Antennas Not Attached to a Tower* • <del>No Parking Requirements</del>	L-ZP	L-ZP	L-ZP	L-ZP	L-ZP	L-ZP	L-ZP	L-ZP	§ 11.5.2
	Communication Services • <del>Vehicle: .5 / 1,000 sf GFA</del> • <del>Bicycle: No requirement</del>	NP	NP	NP	NP	NP	P-ZP	L-ZP/ZPSE	G-MS-3: L-ZP/ZPSE G-MS-5: P-ZP	§ 11.5.1
	Telecommunications Towers* • <del>No Parking Requirements</del>	L-ZP/ ZPIN/ ZPSE	L-ZP/ ZPIN/ ZPSE	L-ZP/ ZPIN/ ZPSE	L-ZP/ ZPIN/ ZPSE	L-ZP/ ZPIN/ ZPSE	L-ZP/ZPIN/ ZPSE	L-ZP/ZPIN/ ZPSE	L-ZP/ZPIN/ ZPSE	§ 11.5.2
	Telecommunications Tower - Alternative Structure* • <del>No Parking Requirements</del>	L-ZP/ ZPIN	L-ZP/ ZPIN	L-ZP/ ZPIN	L-ZP/ ZPIN	L-ZP/ZPIN	L-ZP/ZPIN	L-ZP/ZPIN	L-ZP/ZPIN	§ 11.5.2
	Telecommunication Facilities -- All Others* • <del>No Parking Requirements</del>	L-ZPIN	L-ZPIN	L-ZPIN	L-ZPIN	L-ZPIN	L-ZPIN	L-ZPIN	L-ZPIN	§ 11.5.2
Industrial Services	Contractors, Special Trade - General • <del>Vehicle: .5 / 1,000 sf GFA</del> • <del>Bicycle: No requirement</del>	NP	NP	NP	NP	NP	NP	L-ZP	L-ZP	§ 11.5.3
	Contractors, Special Trade - Heavy/ Contractor Yard*	NP	NP	NP	NP	NP	NP	NP	NP	
	Food Preparation and Sales, Commercial • <del>Vehicle: .5 / 1,000 sf GFA</del> • <del>Bicycle: No requirement</del>	NP	NP	NP	NP	NP	L-ZP	L-ZP	L-ZP	§ 11.5.5
	Laboratory, Research, Development and Technological Services Service/Repair, Commercial • <del>Vehicle: .5 / 1,000 sf GFA</del> • <del>Bicycle: No requirement</del>	NP	NP	NP	NP	NP	NP	L-ZP	L-ZP	§ 11.5.6
Manufacturing and Production	Manufacturing, Fabrication & Assembly -- Custom • <del>Vehicle: .5 / 1,000 sf GFA</del> • <del>Bicycle: No requirement</del>	NP	NP	NP	NP	NP	L-ZPIN	L-ZP	L-ZP	§ 11.5.8
	Manufacturing, Fabrication & Assembly -- General	NP	NP	NP	NP	NP	NP	NP	NP	
	Manufacturing, Fabrication & Assembly -- Heavy	NP	NP	NP	NP	NP	NP	NP	NP	
Mining & Extraction and Energy Producing Systems	Oil, Gas -- Production, Drilling*	NP	NP	NP	NP	NP	NP	NP	NP	
	Sand or Gravel Quarry*	NP	NP	NP	NP	NP	NP	NP	NP	
	Wind Energy Conversion Systems* • <del>No Parking Requirements</del>	L-ZPIN/ ZPSE	L-ZPIN/ ZPSE	L-ZPIN/ ZPSE	L-ZPIN/ ZPSE	L-ZPIN/ ZPSE	L-ZP/ZPIN/ ZPSE	L-ZP/ZPIN/ ZPSE	L-ZP/ZPIN/ ZPSE	§ 11.5.13

KEY: \* = Need Not be Enclosed P = Permitted Use without Limitations L = Permitted Use with Limitations NP = Not Permitted Use ZP = Zoning Permit Review  
 ZPCIM = Subject to Zoning Permit Review with Community Information Meeting ZPIN = Subject to Zoning Permit Review with Informational Notice  
 ZPSE = Subject to Zoning Permit with Special Exception Review When no ZP, ZPCIM, ZPIN, ZPSE listed = No Zoning Permit required

USE CATEGORY	SPECIFIC USE TYPE <ul style="list-style-type: none"> <li>• <del>Vehicle Parking Reqmt: # spaces per unit of measurement</del></li> <li>• <del>Bicycle Parking Reqmt Requirement: # spaces per unit of measurement (% Required Spaces in Enclosed Facility / % Required Spaces in Fixed Facility)</del></li> </ul>								APPLICABLE USE LIMITATIONS
		G-RH-3	G-MU-3 G-MU-5 G-MU-8	G-MU-12 G-MU-20	G-RO-3 G-RO-5	G-RX-3 G-RX-5	G-MX-3	G-MS-3 G-MS-5	
Transportation Facilities	Airport*	NP	NP	NP	NP	NP	NP	NP	
	Helipad, Helistop, Heliport* • <del>No Parking Requirements</del>	L-ZPIN	L-ZPIN	L-ZPIN	L-ZPIN	L-ZPIN	L-ZP	L-ZP	§ 11.5.14
	Railroad Facilities*	NP	NP	NP	NP	NP	NP	NP	
	Railway Right-of-Way* • <del>No Parking Requirements</del>	P-ZP	P-ZP	P-ZP	P-ZP	P-ZP	P-ZP	P-ZP	
	Terminal, Station or Service Facility for Passenger Transit System • <del>Vehicle: .5/1,000 sf GFA</del> • <del>Bicycle: No requirement</del>	L-ZP	L-ZP	L-ZP	L-ZP	L-ZP	P-ZP	P-ZP	§ 11.5.16
	Terminal, Freight, Air Courier Services	NP	NP	NP	NP	NP	NP	NP	
Waste Related Services	Automobile Parts Recycling Business*	NP	NP	NP	NP	NP	NP	NP	
	Junkyard*	NP	NP	NP	NP	NP	NP	NP	
	Recycling Center	NP	NP	NP	NP	NP	NP	NP	
	Recycling Collection Station	NP	NP	NP	NP	NP	NP	NP	
	Recycling Plant, Scrap Processor	NP	NP	NP	NP	NP	NP	NP	
	Solid Waste Facility	NP	NP	NP	NP	NP	NP	NP	
Wholesale, Storage, Warehouse & Distribution	Automobile Towing Service Storage Yard*	NP	NP	NP	NP	NP	NP	NP	
	Mini-storage Facility • <del>Vehicle: 0.1/1,000 sf GFA</del> • <del>Bicycle: No requirement</del>	NP	NP	NP	NP	NP	L-ZP	NP	§ 11.5.23
	Vehicle Storage, Commercial*	NP	NP	NP	NP	NP	NP	NP	
	Wholesale Trade or Storage, General	NP	NP	NP	NP	NP	NP	NP	
	Wholesale Trade or Storage, Light • <del>Vehicle: .5/1,000 sf GFA</del> • <del>Bicycle: No requirement</del>	NP	NP	NP	NP	NP	L-ZP/ZPIN/ ZPSE	L-ZP/ZPIN/ ZPSE	§ 11.5.26
<b>AGRICULTURE PRIMARY USE CLASSIFICATION</b>									
Agriculture	Aquaculture*	NP	NP	NP	NP	NP	NP	NP	
	Garden, Urban* • <del>Vehicle: .5/1,000 sf GFA</del> • <del>Bicycle: No requirement</del>	L-ZP	L-ZP	L-ZP	L-ZP	L-ZP	L-ZP	L-ZP	§ 11.6.2
	Husbandry, Animal*	NP	NP	NP	NP	NP	NP	NP	
	Husbandry, Plant*	NP	NP	NP	NP	NP	NP	NP	
	Plant Nursery • <del>Vehicle: .5/1,000 sf GFA</del> • <del>Bicycle: No requirement</del>	NP	NP	NP	NP	L-ZP	L-ZP	L-ZP	§ 11.6.5

KEY: \* = Need Not be Enclosed P = Permitted Use without Limitations L = Permitted Use with Limitations NP = Not Permitted Use ZP = Zoning Permit Review  
ZPCIM = Subject to Zoning Permit Review with Community Information Meeting ZPIN = Subject to Zoning Permit Review with Informational Notice  
ZPSE = Subject to Zoning Permit with Special Exception Review When no ZP, ZPCIM, ZPIN, ZPSE listed = No Zoning Permit required

USE CATEGORY	SPECIFIC USE TYPE • <del>Vehicle Parking Reqmt: # spaces per unit of measurement</del> • <del>Bicycle Parking Reqmt Requirement: # spaces per unit of measurement (% Required Spaces in Enclosed Facility / % Required Spaces in Fixed Facility)</del>	SPECIFIC USE TYPE							APPLICABLE USE LIMITATIONS
		G-RH-3	G-MU-3 G-MU-5 G-MU-8	G-MU-12 G-MU-20	G-RO-3 G-RO-5	G-RX-3 G-RX-5	G-MX-3	G-MS-3 G-MS-5	

ACCESSORY TO PRIMARY RESIDENTIAL USES USE CLASSIFICATION

USE CATEGORY	SPECIFIC USE TYPE	L - Applicable to all Zone Districts							APPLICABLE USE LIMITATIONS
		L-ZP	L-ZP	L-ZP	L-ZP	L-ZP	L-ZP	L-ZP	
Accessory to Primary Residential Uses  ( <del>Parking is Not Required for Accessory Uses Unless Specifically Stated in this Table or in an Applicable Use Limitation</del> )	Unlisted Accessory Uses	L - Applicable to all Zone Districts							§ 11.7
	Accessory Dwelling Unit	L-ZP	L-ZP	L-ZP	L-ZP	L-ZP	L-ZP	L-ZP	§ 11.7, § 11.8.2
	Domestic Employees	L	L	L	L	L	L	L	§11.7.1; §11.8.3
	Garden*	L	L	L	L	L	L	L	§ 11.7, § 11.8.4
	Keeping of Household Animals*	L/L-ZPIN	L/L-ZPIN	L/L-ZPIN	L/L-ZPIN	L/L-ZPIN	L/L-ZPIN	L/L-ZPIN	§ 11.7; § 11.8.5
	Keeping and Off-Street Parking of Vehicles, Motorcycles, Trailers & Recreational Vehicles*	L	L	L	L	L	L	L	§ 11.7; § 10.9
	Kennel or Exercise Run*	L	L	L	L	L	L	L	§ 11.7; § 11.8.6
	Limited Commercial Sales, Services Accessory to Multi-Unit Dwelling Use	NP	L-ZP	L-ZP	L-ZP	L-ZP	Not Applicable - See Permitted Primary Uses		§ 11.7; § 11.8.7
	Outdoor Storage, Residential*	L	L	L	L	L	L	L	§11.7; §11.8.8
	Second Kitchen Accessory to Single Unit Dwelling Use	L-ZP	L-ZP	L-ZP	L-ZP	L-ZP	L-ZP	L-ZP	§ 11.7; § 11.8.9
	Short-term Rental	L	L	L	L	L	L	L	§ 11.7; § 11.8.10
	Vehicle Storage, Repair and Maintenance*	L	L	L	L	L	L	L	§ 11.7; § 10.9.
Wind Energy Conversion Systems*	L-ZPIN/ ZPSE	L-ZPIN/ ZPSE	L-ZPIN/ ZPSE	L-ZPIN/ ZPSE	L-ZPIN/ ZPSE	Not Applicable - See Permitted Primary Uses		§ 11.7; § 11.5.13	
Yard or Garage Sales*	L	L	L	L	L	L	L	§ 11.7; § 11.8.11	

HOME OCCUPATIONS ACCESSORY TO PRIMARY RESIDENTIAL USES USE CLASSIFICATION

USE CATEGORY	SPECIFIC USE TYPE	L - Applicable to all Zone Districts							APPLICABLE USE LIMITATIONS
		L-ZP	L-ZP	L-ZP	L-ZP	L-ZP	L-ZP	L-ZP	
Home Occupations  ( <del>Parking is Not Required for Home Occupations Unless Specifically Stated in this Table or in an Applicable Use Limitation</del> )	Child Care Home, Large	L-ZP	L-ZP	L-ZP	L-ZP	L-ZP	L-ZP	L-ZP	§ 11.9; § 11.9.3
	All Other Types	L-ZP	L-ZP	L-ZP	L-ZP	L-ZP	L-ZP	L-ZP	§ 11.9; § 11.9.4
	Unlisted Home Occupations	L-ZPIN	L-ZPIN	L-ZPIN	L-ZPIN	L-ZPIN	L-ZPIN	L-ZPIN	§ 11.9; § 11.9.5

KEY: \* = Need Not be Enclosed P = Permitted Use without Limitations L = Permitted Use with Limitations NP = Not Permitted Use ZP = Zoning Permit Review  
 ZPCIM = Subject to Zoning Permit Review with Community Information Meeting ZPIN = Subject to Zoning Permit Review with Informational Notice  
 ZPSE = Subject to Zoning Permit with Special Exception Review When no ZP, ZPCIM, ZPIN, ZPSE listed = No Zoning Permit required

USE CATEGORY	SPECIFIC USE TYPE • <del>Vehicle Parking Reqmt: # spaces per unit of measurement</del> • <del>Bicycle Parking Reqmt Requirement: # spaces per unit of measurement (% Required Spaces in Enclosed Facility / % Required Spaces in Fixed Facility)</del>	G-MU-12 G-MU-3 G-MU-5 G-MU-8 G-MU-20 G-RO-3 G-RO-5 G-RX-3 G-RX-5 G-MX-3 G-MS-3 G-MS-5							APPLICABLE USE LIMITATIONS		
		G-RH-3	G-MU-3	G-MU-5	G-MU-8	G-MU-20	G-RO-3	G-RO-5		G-RX-3	G-RX-5

**ACCESSORY TO PRIMARY NONRESIDENTIAL USES USE CLASSIFICATION**

USE CATEGORY	SPECIFIC USE TYPE	L - Applicable to all Zone Districts							APPLICABLE USE LIMITATIONS		
		G-RH-3	G-MU-3	G-MU-5	G-MU-8	G-MU-20	G-RO-3	G-RO-5		G-RX-3	G-RX-5
Accessory to Primary Nonresidential Uses  (Parking is Not Required for Accessory Uses Unless Specifically Stated in this Table or in an Applicable Use Limitation)	Unlisted Accessory Uses	L - Applicable to all Zone Districts							\$ 11.7; § 11.10.1		
	Amusement Devices Accessory to Eating/Drinking Establishments, College/University and Theater Uses	NP	NP	NP	NP	NP	L-ZP	L-ZP	L-ZP	\$ 11.7; § 11.10.2	
	Automobile Rental Services Accessory to Certain Retail Uses*	NP	NP	NP	NP	NP	Not Applicable - See Permitted Primary Uses	Not Applicable - See Permitted Primary Uses	Not Applicable - See Permitted Primary Uses	\$ 11.7; § 11.10.3	
	Book or gift store; media recording and production facilities accessory to public libraries, museums, places of religious assembly, colleges or universities	L	L	L	L	L	Not Applicable - See Permitted Primary Uses			\$11.7; §11.10.4	
	Car Wash Bay Accessory to Automobile Services or Hotel Uses	NP	NP	NP	NP	NP	L-ZP	L-ZP	NP	\$ 11.7; § 11.10.5	
	College Accessory to a Place for Religious Assembly	L	Not Applicable - See Permitted Primary Uses			L	Not Applicable - See Permitted Primary Uses			\$ 11.7; § 11.10.6	
	Conference Facilities Accessory to Hotel Use	NP	NP	NP	NP	NP	L	L	L	\$ 11.7; § 11.10.7	
	Drive Through Facility Accessory to Eating/Drinking Establishments and to Retail Sales, Service, and Repair Uses*	NP	NP	NP	NP	NP	NP	L-ZP	L-ZP	\$ 11.7; § 11.10.8	
	Emergency Vehicle Access Point Garden*	NP	NP	NP	NP	NP	NP	NP	NP	\$11.7; §11.10.10	
	Emergency Vehicle Access Point Garden*	L	L	L	L	L	L	L	L	\$11.7; §11.10.10	
	Keeping of Animals	L/L-ZPIN	L/L-ZPIN	L/L-ZPIN	L/L-ZPIN	L/L-ZPIN	L/L-ZPIN	L/L-ZP/L-ZPIN	L/L-ZP/L-ZPIN	\$11.7; § 11.10.11	
	Limited Commercial Sales, Services	L	L	L	L	L	L	L	L	\$11.7; §11.10.12	
	Nonresidential Uses in Existing Business Structures In Residential Zones - Accessory Uses	L	L	L	L	L	Not Applicable - See Permitted Primary Uses	Not Applicable		\$11.7; §11.4.6	
	Occasional Sales, Services Accessory to Primary Places of Religious Assembly or Primary Uses Operated by Nonprofit Organizations*	L	L	L	L	L	L	L	L	\$11.7; §11.10.13	
	Outdoor Gathering Area*	L/L-ZP/L-ZPIN	L/L-ZP/L-ZPIN	L/L-ZP/L-ZPIN	L/L-ZP/L-ZPIN	L/L-ZP/L-ZPIN	L/L-ZP/L-ZPIN	L/L-ZP/L-ZPIN	L/L-ZP/L-ZPIN	\$11.7; §11.10.14	
	Outdoor Entertainment Accessory to an Eating/Drinking Establishment Use*	NP	NP	NP	NP	NP	L-ZPIN/ZPSE	L-ZPIN/ZPSE	L-ZPIN/ZPSE	\$11.7; §11.10.15	
	Outdoor Retail Sale and Display*	NP	NP	NP	NP	NP	L-ZP/ZPSE	L-ZP/ZPSE	L-ZP/ZPSE	\$11.7; §11.10.16	
	Outdoor Storage, General*	NP	NP	NP	NP	NP	NP	NP	NP	\$11.7; §11.10.18	
	Outdoor Storage, Limited*	NP	NP	NP	NP	NP	NP	L	L	\$11.7; §11.10.18	
Rental or Sales of Adult Material Accessory to a Permitted Bookstore Retail Sales Use	NP	NP	NP	NP	NP	L	L	L	\$11.7; §11.10.20		
Retail Food Establishment, Mobile (Food Truck)*	L-ZP	L-ZP	L-ZP	L-ZP	L-ZP	L-ZP	L-ZP	L-ZP	\$11.7; §11.10.19		

KEY: \* = Need Not be Enclosed P = Permitted Use without Limitations L = Permitted Use with Limitations NP = Not Permitted Use ZP = Zoning Permit Review  
ZPCIM = Subject to Zoning Permit Review with Community Information Meeting ZPIN = Subject to Zoning Permit Review with Informational Notice  
ZPSE = Subject to Zoning Permit with Special Exception Review When no ZP, ZPCIM, ZPIN, ZPSE listed = No Zoning Permit required

USE CATEGORY	SPECIFIC USE TYPE • Vehicle Parking Reqmt: # spaces per unit of measurement • Bicycle Parking Reqmt Requirement: # spaces per unit of measurement (% Required Spaces in Enclosed Facility / % Required Spaces in Fixed Facility)	APPLICABLE USE LIMITATIONS						
		G-RH-3	G-MU-3 G-MU-5 G-MU-8	G-MU-12 G-MU-20	G-RO-3 G-RO-5	G-RX-3 G-RX-5	G-MX-3	G-MS-3 G-MS-5

**TEMPORARY USE CLASSIFICATION**

Temporary Uses (Parking is Not Required for Temporary Uses Unless Specifically Stated in this Table or in an Applicable Use Limitations)	Unlisted Temporary Uses	L- Applicable to all Zone Districts							§ 11.11.1
	Ambulance Service - Temporary	NP	L-ZP	L-ZP	L-ZP	L-ZP	Not Applicable - See Permitted Primary Uses		§ 11.11.2
Amusement / Entertainment - Temporary*	NP	NP	NP	NP	NP	NP	NP		
Bazaar, Carnival, Circus or Special Event*	L-ZP	L-ZP	L-ZP	L-ZP	L-ZP	L-ZP	L-ZP	§ 11.11.4	
Building or yard for construction materials*	L-ZP	L-ZP	L-ZP	L-ZP	L-ZP	L-ZP	L-ZP	§ 11.11.5	
Concrete, Asphalt, and Rock Crushing Facility*	L-ZP	L-ZP	L-ZP	L-ZP	L-ZP	L-ZP	L-ZP	§ 11.11.6	
Fence for Demolition or Construction Work	L-ZP	L-ZP	L-ZP	L-ZP	L-ZP	L-ZP	L-ZP	§ 11.11.7	
Health Care Center	L-ZP	L-ZP	L-ZP	L-ZP	L-ZP	L-ZP	P-ZP	§ 11.11.8	
Noncommercial Concrete Batching Plant*	L-ZP	L-ZP	L-ZP	L-ZP	L-ZP	L-ZP	L-ZP	§ 11.11.9	
Outdoor Retail Sales - Pedestrian / Transit Mall*	NP	NP	NP	NP	NP	NP	NP		
Outdoor Retail Sales*	NP	NP	NP	NP	L-ZP	L-ZP	NP	§ 11.11.11	
Outdoor Sales, Seasonal*	NP	NP	NP	NP	L-ZPIN	L-ZP	L-ZP	§ 11.11.12	
Parking Lot Designated for a Special Event*	L-ZP	L-ZP	L-ZP	L-ZP	L-ZP	L-ZP	L-ZP	§ 11.11.13	
Retail Food Establishment, Mobile (Food Truck)*	NP	NP	NP	NP	L/L-ZP	L/L-ZP	NP	§ 11.11.14	
Temporary Construction Office	L-ZP	L-ZP	L-ZP	L-ZP	L-ZP	L-ZP	L-ZP	§ 11.11.15	
Temporary Office - Real Estate Sales	L-ZP	L-ZP	L-ZP	L-ZP	L-ZP	L-ZP	L-ZP	§ 11.11.16	
Temporary Managed Community*	L-ZPCIM	L-ZPCIM	L-ZPCIM	L-ZPCIM	L-ZPCIM	L-ZPCIM	L-ZPCIM	§ 11.11.17	
Tent for Religious Services	NP	NP	NP	NP	NP	NP	NP		



## SECTION 7.3.3 BUILDING FORM STANDARDS FOR PRIMARY STRUCTURES

### 7.3.3.1 Applicability

All development, except detached accessory structures, in all the Urban Center Neighborhood Context zone districts

### 7.3.3.2 District Specific Standards Summary

The table below states the building forms allowed in each zone district. The table also summarizes the maximum number of structures allowed per Zone Lot, which is stated in more detail in Section 1.2.3.5, Number of Uses and Structures Allowed per Zone Lot.

See also Division 1.4, Building Form Standards - General Provisions, for additional standards related to initial assignment of building form standards to new and existing structures and for rules governing combining or changing building forms. Building Connectors between two detached structures shall follow the standards provided in Section 1.4.5, Applicable Building Form Standards for Detached Structures with Building Connector.

Urban Center (C-) Neighborhood Context Zone Districts		Building Forms															
		Suburban House	Urban House	Duplex	Tandem House	Row House	Garden Court	Town House	Apartment	Drive Thru Services	Drive Thru Restaurant	General	Cherry Creek General	Cherry Creek General - Small Lot on South Side of 3rd Ave	Cherry Creek Open Space	Cherry Creek Open Space - Small Lot on South Side of 3rd Ave	Shopfront
<b>Max Number of Primary Structures per Zone Lot</b>		No Maximum															
Residential Mixed Use (RX)	C-RX-5, -8, -12						■					■					
Mixed Use (MX)	C-MX-3, -5, -8, -12, -16, -20						■		□	□		■					■
Main Street (MS)	C-MS-5, -8, -12						■		□	□							■
Cherry Creek North (CCN)	C-CCN-3, -4, -5											■	■	■	■		
	C-CCN-7, -8, -12											■		■			

■ = Allowed □ = Allowed subject to geographic limitations

### 7.3.3.3 District Specific Standards

#### A. Town House

Not to Scale. Illustrative Only.



## TOWN HOUSE

<b>HEIGHT</b>		C-MX-3	C-MX-5, -8, -12, -16, -20	C-RX-5, -8, -12	C-MS-5, -8, -12
A	Stories (max)	3	5	5	5
A	Feet (min/max)	na/38'	na/70'	na/70'	24'/70'
<b>SITING</b>		C-MX-3	C-MX-5, -8, -12, -16, -20	C-RX-5, -8, -12	C-MS-5, -8, -12
<b>REQUIRED BUILD-TO</b>					
B	Primary Street (min build-to % within min/max range)	70%	70%	70%	75%
		10'/15'	10'/15'	10'/15'	10'/15'
	Side Street (min build-to % within min/max range)	na	na	na	25%
					7.5'/15'
<b>SETBACKS</b>					
C	Primary Street (min)	10'	10'	10'	10'
D	Side Street (min)	7.5'	7.5'	7.5'	7.5'
E	Side Interior (min)	5'	5'	5'	5'
F	Side Interior, adjacent to Protected District (min)	10'	10'	10'	10'
	Rear (min)	0'	0'	0'	0'
	Rear, adjacent to Protected District, where Alley (public or private) abuts a Rear Zone Lot Line (min)	0'	0'	0'	0'
	Rear, adjacent to Protected District, where no Alley (public or private) abuts a Rear Zone Lot Line	10'	10'	10'	10'
<b>PARKING</b>					
	Surface Parking between building and Primary Street/Side Street	Not Allowed/Not Allowed			
	Vehicle Access	From Alley; or Street access allowed when no Alley present. See Sec. 7.3.5.7.			
<b>DESIGN ELEMENTS</b>		C-MX-3	C-MX-5, -8, -12, -16, -20	C-RX-5, -8, -12	C-MS-5, -8, -12
<b>BUILDING CONFIGURATION</b>					
G	Dwelling Units Oriented to the Street	Required if any portion of the Dwelling Unit is located within 20' of Primary Street Zone Lot Line or 20' of the Side Street Zone Lot Line.			
	Dwelling Unit Configuration	Structure may contain Side-by-Side Dwelling Units			
H	Upper Story Setback Above 27', adjacent to Protected District: Rear, alley/Rear, no alley and Side Interior (min)	15'/25'	20'/25'	20'/25'	20'/25'
	Upper Story Setback Above 51', adjacent to Protected District: Rear, alley/Rear, no alley and Side Interior (min)	na	35'/40'	35'/40'	35'/40'
<b>STREET LEVEL ACTIVATION</b>					
I	Transparency, Primary Street (min)	40%	40%	40%	40%
	Transparency, Side Street (min)	25%	25%	25%	25%
J	Pedestrian Access	Each Dwelling Unit Oriented to the Street shall have Dwelling Unit Entrance with Entry Feature.			
<b>USES</b>		All C-MX	All C-RX	All C-MS	
	Street Level Active Uses (min % of Primary Street front-age meeting Build-To requirement)	100%	na	100%	
	Permitted Primary Uses	Primary Uses shall be limited to Two Unit Dwelling and Multi Unit Dwelling (3+) uses. See Div. 7.4, Uses, <b>and Required Minimum Parking</b>			

See Sections 7.3.5 - 7.3.7 for Supplemental Design Standards, Design Standard Alternatives and Design Standard Exceptions

## DRIVE THRU SERVICES

APPLICABILITY		All C-MX, C-MS	
Form is not permitted on Zone Lots within 1/4 mile of the outer boundary of a Rail Transit Station Platform			
HEIGHT		All C-MX, C-MS	
Stories (max)		3	
Feet (max)		45'	
SITING		All C-MS	All C-MX
REQUIRED BUILD-TO			
Primary Street (min % within min/max)*		50% 0'/15'	50% 0'/15'
Side Street (min % within min/max)*		50% 0'/15'	50% 0'/15'
SETBACKS			
Primary Street (min)		0'	0'
Side Street (min)		0'	0'
Side Interior (min)		0'	0'
Side Interior, adjacent to Protected District (min)		10'	10'
Rear (min)		0'	0'
Rear, adjacent to Protected District, where Alley (public or private) abuts a Rear Zone Lot Line (min)		0'	0'
Rear, adjacent to Protected District, where no Alley (public or private) abuts a Rear Zone Lot Line		10'	10'
PARKING			
Surface Parking between building and Primary Street/ Side Street		Not Allowed/Not Allowed	
Surface Parking Screening Required		See Sec. 10.5, Landscaping, Fences, Walls and Screening	
Vehicle Access		Shall be determined as part of Site Development Plan Review	
DESIGN ELEMENTS		All C-MS	All C-MX
BUILDING CONFIGURATION			
A *Canopy		Building shall be used to meet a portion of the Primary and Side Street Build-To. Canopy may be used to meet a portion of the Primary and Side Street Build-To	
B Screening Required		Garden Wall required within 0'/15' for 100% of the Primary and Side Street, excluding access points and portions of building within 0'/15', following the standards of Sec. 10.5.4.4.	
Upper Story Setback Above 27', adjacent to Protected District: Rear, alley/Rear, no alley and Side, interior (min)		15'/25'	15'/25'
STREET LEVEL ACTIVATION			
C Transparency, Primary Street (min)		60%	40%
D Transparency, Side Street (min)		25%	25%
E Pedestrian Access, Primary Street		Entrance	Entrance
USES		All C-MS	All C-MX
For Primary Structures constructed on or before June 25, 2010, all permitted Primary Uses shall be allowed within this building form; however, for Primary Structures constructed after June 25, 2010, Primary Uses shall be limited to Automobile Services, Light and/or Primary Use with Accessory Drive Thru Use, excluding Eating & Drinking Establishments. See Div. 7.4, Uses, <del>and Required</del> <b>Minimum Parking</b>			

## DRIVE THRU RESTAURANT

<b>APPLICABILITY</b>		<b>All C-MX, C-MS</b>	
Form is not permitted on Zone Lots within 1/4 mile of the outer boundary of a Rail Transit Station Platform			
<b>HEIGHT</b>		<b>All C-MX</b>	<b>All C-MS</b>
Stories (max)		3	3
Feet (max)		45'	45'
<b>SITING</b>		<b>All C-MX</b>	<b>All C-MS</b>
<b>REQUIRED BUILD-TO</b>			
Primary Street (min % within min/max)		Corner Lots: 50% 0'/10' All other: 70% 0'/10'	Corner Lots: 50% 0'/5' All other: 75% 0'/5'
Side Street (min % within min/max)		50% 0'/10'	50% 0'/5'
<b>SETBACKS</b>			
Primary Street (min)		0'	0'
Side Street (min)		0'	0'
Side Interior (min)		0'	0'
Side Interior, adjacent to Protected District (min)		10'	10'
Rear (min)		0'	0'
Rear, adjacent to Protected District, where Alley (public or private) abuts a Rear Zone Lot Line (min)		0'	0'
Rear, adjacent to Protected District, where no Alley (public or private) abuts a Rear Zone Lot Line		10'	10'
<b>PARKING</b>			
Surface Parking between building and Primary Street/ Side Street		Not Allowed/Not Allowed	
Drive Thru Lane between building and Primary Street/ Side Street		Not Allowed/Not Allowed	
Vehicle Access		Shall be determined as part of Site Development Plan Review	
<b>DESIGN ELEMENTS</b>		<b>All C-MX</b>	<b>All C-MS</b>
<b>BUILDING CONFIGURATION</b>			
Upper Story Setback Above 27', adjacent to Protected District: Rear, alley/Rear, no alley and Side Interior (min)		15'/25'	15'/25'
<b>STREET LEVEL ACTIVATION</b>			
<b>A</b> Transparency, Primary Street (min)		40%	60%
<b>B</b> Transparency, Side Street (min)		25%	25%
<b>C</b> Pedestrian Access, Primary Street		Entrance	Entrance
<b>USES</b>		<b>All C-MX</b>	<b>All C-MS</b>

For Primary Structures constructed on or before June 25, 2010, all permitted Primary Uses shall be allowed within this building form; however, for Primary Structures constructed after June 25, 2010, Primary Uses shall be limited to an Eating & Drinking Establishment Primary Use with Accessory Drive Thru Use Only. See Div. 7.4, Uses **and Required Minimum Parking**.

## GENERAL

HEIGHT	C-MX-3	C-RX-5 C-MX-5	C-RX-8 C-MX-8	C-RX-12 C-MX-12	C-MX-16	C-MX-20
	Stories (max)	3	5	8	12	16
Feet (max)	45'	70'	110'	150'	200'	250'
Stories/Feet, with incentives (max)	4/55'	7/95'	12/150'	16/200'	22/275'	30/375'
Feet, within 175' of Protected District (max)	na	75'	75'	75'	75'	75'

SITING	C-MX-3	C-RX-5 C-MX-5	C-RX-8 C-MX-8	C-RX-12 C-MX-12	C-MX-16	C-MX-20
--------	--------	------------------	------------------	--------------------	---------	---------

### REQUIRED BUILD-TO

A Primary Street (min build-to % within min/max range)	70% 0'/10' Residential Only Buildings: 0'/15'
--	--

### SETBACKS

Primary Street (min)	0'
Side Street (min)	0'
Side Interior (min)	0'
B Side Interior, adjacent to Protected District (min)	10'
Rear, (min)	0'
Rear, adjacent to Protected District, where Alley (public or private) abuts a Rear Zone Lot Line (min)	0'
Rear, adjacent to Protected District, where Alley (public or private) does not abut a Rear Zone Lot Line (min)	10'

### PARKING

Surface Parking between building and Primary Street/Side Street	Not Allowed/Not Allowed
C Surface Parking Screening Required	See Div. 10.5, Landscaping, Fences, Walls and Screening
Vehicle Access	Shall be determined as part of Site Development Plan Review

DESIGN ELEMENTS	C-MX-3	C-RX-5 C-MX-5	C-RX-8 C-MX-8	C-RX-12 C-MX-12	C-MX-16	C-MX-20
-----------------	--------	------------------	------------------	--------------------	---------	---------

### BUILDING CONFIGURATION

Dwelling Unit Configuration	Structure may contain Side-by-Side Dwelling Units Residential Only Structure: Side-by-Side Dwelling Units shall not exceed 50% of the Structure's GFA					
D Upper Story Setback Above 27', adjacent to Protected District: Rear, alley/Rear, no alley and Side Interior (min)	15'/25'	20'/25'	20'/25'	20'/25'	20'/25'	20'/25'
E Upper Story Setback Above 51', adjacent to Protected District: Rear, alley/Rear, no alley and Side Interior (min)	na	35'/40'	35'/40'	35'/40'	35'/40'	35'/40'

### STREET LEVEL ACTIVATION

F Transparency, Primary Street (min)	40%
G Transparency, Side Street (min)	25%
H Pedestrian Access, Primary Street	Entrance

USES	All C-MX	All C-RX
------	----------	----------

Street Level Active Uses (min % of Primary Street front-age meeting Build-To requirement)	100%	na
---	------	----

Permitted Primary Uses	All permitted Primary Uses shall be allowed within this building form. See Division 7.4, Uses <del>and</del> <b>Required Minimum Parking.</b>	All permitted Primary Uses shall be allowed within this building form; however: (1) Second Story and Above: Residential or Lodging Accommodations uses only; and (2) Buildings with No Residential or Lodging Accommodation Uses: 10,000 sf GFA max
------------------------	---	---

See Sections 7.3.5 - 7.3.7 for Supplemental Design Standards, Design Standard Alternatives and Design Standard Exceptions

## CHERRY CREEK GENERAL

<b>HEIGHT</b>		C-CCN-3	C-CCN-4	C-CCN-5	C-CCN-7	C-CCN-8	C-CCN-12
	Stories (max)	3	4	5	7	8	12
	Feet (max)	45'	57'	70'	96'	110'	150'
<b>A</b>	3rd Avenue CCN Bulk Plane Applies (See Div. 13.1)	Yes	Yes	Yes	Yes	Yes	Yes

<b>SITING</b>		C-CCN-3	C-CCN-4	C-CCN-5	C-CCN-7	C-CCN-8	C-CCN-12
<b>REQUIRED BUILD-TO</b>							
<b>B</b>	Primary Street (% within min/max)	70% 5'/15'	70% 5'/15'	70% 5'/15'	70% 5'/15'	70% 5'/15'	70% 5'/15'
<b>SETBACKS</b>							
	Primary Street (min)	5'	5'	5'	5'	5'	5'
	Side Interior (min)	0'	0'	0'	0'	0'	0'
<b>C</b>	Side Interior, adjacent to Protected District (min)	10'	10'	10'	10'	10'	10'
	Rear (min)	0'	0'	0'	0'	0'	0'
	Rear, adjacent to Protected District, where Alley (public or private) abuts a Rear Zone Lot Line (min)	0'	0'	0'	0'	0'	0'
	Rear, adjacent to Protected District, where Alley (public or private) does not abut a Rear Zone Lot Line	10'	10'	10'	10'	10'	10'
<b>PARKING</b>							
	Surface Parking between building and Primary Street	Not Allowed					
<b>D</b>	Surface Parking Screening Required	See Div. 10.5, Landscaping, Fences, Walls and Screening					
	Vehicle Access	See Sec. 7.3.5.6					

<b>DESIGN ELEMENTS</b>		C-CCN-3	C-CCN-4	C-CCN-5	C-CCN-7	C-CCN-8	C-CCN-12
<b>BUILDING CONFIGURATION</b>							
<b>E</b>	Mass Reduction where Zone Lot Area is greater than 9,375 square feet (min)	25%	25%	25%	25%	25%	25%
	Mass Reduction where Zone Lot Area is 9,375 square feet or less, as of October 27, 2014 (min)	na	na	na	na	na	na
<b>F</b>	Upper Story Setback Above 27'; adjacent to Protected District: Rear, alley/Rear, no alley and Side Interior (min)	20'/25'	20'/25'	20'/25'	20'/25'	20'/25'	20'/25'
<b>G</b>	Upper Story Setback Above 51'; adjacent to Protected District: Rear, alley/Rear, no alley and Side Interior (min)	na	35'/40'	35'/40'	35'/40'	35'/40'	35'/40'
<b>STREET LEVEL ACTIVATION</b>							
<b>H</b>	Transparency, Primary Street (min)	60%					
<b>I</b>	Pedestrian Access, min 1 per building	Entrance					
<b>USES</b>		All C-CCN					
All permitted Primary Uses shall be allowed within this building form. See Div. 7.4, Uses <b>and Required Minimum Parking</b> .							

## CHERRY CREEK GENERAL - SMALL LOT ON SOUTH SIDE OF 3RD AVE

		C-CCN-3, -4, -5	
<b>HEIGHT</b>		Option A	Option B
	Stories (max)	3	3
	Feet (max)	45'	45'
<b>A</b>	3rd Avenue CCN Bulk Plane Applies (see Div. 13.1)	No	Yes
<b>B</b>	3rd Avenue CCN Bulk Plane Exception	na	50'
		C-CCN-3, -4, -5	
<b>SITING</b>		Option A	Option B
<b>ZONE LOT</b>			
	Zone Lot Area, as of October 27, 2014 (max)	6,250 sf	6,250 sf
<b>C</b>	Zone Lot Width on the south side of 3rd Avenue	At least 1' but no more than 50'	More than 50'
<b>REQUIRED BUILD-TO</b>			
<b>D</b>	Primary Street (% within min/max)	70% 5'/15'	70% 5'/15'
<b>SETBACKS</b>			
	Primary Street (min)	5'	5'
	Side Interior (min)	0'	0'
<b>E</b>	Side Interior, adjacent to Protected District (min)	10'	10'
	Rear (min)	0'	0'
	Rear, adjacent to Protected District, where Alley (public or private) abuts a Rear Zone Lot Line (min)	0'	0'
	Rear, adjacent to Protected District, where Alley (public or private) does not abut a Rear Zone Lot Line	10'	10'
<b>PARKING</b>			
	Surface Parking between building and Primary Street	Not Allowed	
<b>F</b>	Surface Parking Screening Required	See Div. 10.5, Landscaping, Fences, Walls and Screening	
	Vehicle Access	See Sec. 7.3.5.6	
		C-CCN-3, -4, -5	
<b>DESIGN ELEMENTS</b>		Option A	Option B
<b>BUILDING CONFIGURATION</b>			
<b>G</b>	Upper Story Setback Above 27', adjacent to Protected District: Rear, alley/Rear, no alley and Side Interior (min)	20'/25'	20'/25'
	Upper Story Setback Above 51', adjacent to Protected District: Rear, alley/Rear, no alley and Side Interior (min)	na	na
<b>STREET LEVEL ACTIVATION</b>			
<b>H</b>	Transparency, Primary Street (min)	60%	
<b>I</b>	Pedestrian Access, min 1 per building	Entrance	
<b>USES</b>		C-CCN-3, -4, -5: Options A and B	
All permitted Primary Uses shall be allowed within this building form. See Div. 7.4, Uses <del>and Required Minimum Parking</del> .			



## CHERRY CREEK OPEN SPACE - SMALL LOT ON SOUTH SIDE OF 3RD AVE

HEIGHT	C-CCN-3, -4, -5	
	Option A	Option B
Stories (max)	C-CCN-3: 3	C-CCN-3: 3
	C-CCN-4: 4	C-CCN-4: 4
	C-CCN-5: 5	C-CCN-5: 5
Feet (max)	C-CCN-3: 45'	C-CCN-3: 45'
	C-CCN-4: 57'	C-CCN-4: 57'
	C-CCN-5: 70'	C-CCN-5: 70'
3rd Avenue CCN Bulk Plane Applies (See Div. 13.1)	No	No

SITING	C-CCN-3, -4, -5		
	Option A		Option B
<b>ZONE LOT</b>			
Zone Lot Area, as of October 27, 2014 (max)	9,375 sf	6,250 sf	6,250 sf
A Zone Lot Width on the south side of 3rd Avenue	At least 1'	OR	
		At least 1' but no more than 50'	Over 50'

REQUIRED BUILD-TO			
B Primary Street (% within min/max)	70%	70%	70%
	5'/15'	5'/15'	5'/15'

SETBACKS			
Primary Street (min)	5'	5'	5'
Side Interior (min)	0'	0'	0'
C Side Interior, adjacent to Protected District (min)	10'	10'	10'
Rear (min)	0'	0'	0'
Rear, adjacent to Protected District, where Alley (public or private) abuts a Rear Zone Lot Line (min)	0'	0'	0'
Rear, adjacent to Protected District, where Alley (public or private) does not abut a Rear Zone Lot Line (min)	10'	10'	10'

PARKING			
Surface Parking between building and Primary Street		Not Allowed	
D Surface Parking Screening Required	See Div. 10.5, Landscaping, Fences, Walls and Screening		
Vehicle Access		See Sec. 7.3.5.6	

DESIGN ELEMENTS	C-CCN-3, -4, -5	
	Option A	Option B
<b>BUILDING CONFIGURATION</b>		
E Private Open Space (min)	15%	20%
F Upper Story Setback Above 27', adjacent to Protected District: Rear, alley/Rear, no alley and Side Interior (min)	20'/25'	20'/25'
G Upper Story Setback Above 51', adjacent to Protected District: Rear, alley/Rear, no alley and Side Interior (min)	35'/40'	na
H Primary Street Upper Story Setback Above 45' and 3 Stories; where zone lot abuts southern right-of-way of 3rd Avenue (min)	57'	na
<b>STREET LEVEL ACTIVATION</b>		
I Transparency, Primary Street (min)		60%
J Pedestrian Access, min 1 per building		Entrance

USES	C-CCN-3, -4, -5: Options A and B
	All permitted Primary Uses shall be allowed within this building form. See Div. 7.4, Uses <b>and Required Minimum Parking</b> .

## SHOPFRONT

<b>HEIGHT</b>		C-MX-3	C-MS-5 C-MX-5	C-MS-8 C-MX-8	C-MS-12 C-MX-12	C-MX-16	C-MX-20
Stories (max)		3	5	8	12	16	20
A Feet (min/max)		na/45'	24'/70'	24'/110'	24'/150'	24'/200'	24'/250'
Stories/Feet, with incentives (max)		4/55'	7/95'	12/150'	16/200'	22/275'	30/375'
Feet, within 175' of Protected District (max)		na	75'	na	na	na	na
<b>SITING</b>		C-MX-3	C-MS-5 C-MX-5	C-MS-8 C-MX-8	C-MS-12 C-MX-12	C-MX-16	C-MX-20
<b>REQUIRED BUILD-TO</b>							
B Primary Street (min build-to % within min/max range)					75% 0'/5' Residential Only Buildings: 0'/10'		
C Side Street (min build-to % within min/max range)					25% 0'/5' Residential Only Buildings: 0'/10'		
<b>SETBACKS</b>							
Primary Street (min)		0'	0'	0'	0'	0'	0'
Side Street (min)		0'	0'	0'	0'	0'	0'
Side Interior (min)		0'	0'	0'	0'	0'	0'
D Side Interior, adjacent to Protected District (min)		10'	10'	10'	10'	10'	10'
Rear (min)		0'	0'	0'	0'	0'	0'
Rear, adjacent to Protected District, where Alley (public or private) abuts a Rear Zone Lot Line (min)		0'	0'	0'	0'	0'	0'
Rear, adjacent to Protected District, where Alley (public or private) does not abut a Rear Zone Lot Line		10'	10'	10'	10'	10'	10'
<b>PARKING</b>							
Surface Parking between building and Primary Street/Side Street					Not Allowed/Not Allowed		
E Surface Parking Screening Required					See Div. 10.5, Landscaping, Fences, Walls and Screening		
Vehicle Access					Shall be determined as part of Site Development Plan Review		
<b>DESIGN ELEMENTS</b>		C-MX-3	C-MS-5 C-MX-5	C-MS-8 C-MX-8	C-MS-12 C-MX-12	C-MX-16	C-MX-20
<b>BUILDING CONFIGURATION</b>							
Dwelling Unit Configuration					Structure may contain Side-by-Side Dwelling Units Residential Only Structure: Side-by-Side Dwelling Units shall not exceed 50% of the Structure's GFA		
F Primary Street Upper Story Setback above 5 stories or 70' (min) See Section 7.3.6.2 for Alternative		na	na	20'	20'	20'	20'
G Upper Story Setback Above 27', adjacent to Protected District: Rear, alley/Rear, no alley and Side Interior (min)		15'/25'	20'/25'	20'/25'	20'/25'	20'/25'	20'/25'
H Upper Story Setback Above 51', adjacent to Protected District: Rear, alley/Rear, no alley and Side Interior (min)		na	35'/40'	35'/40'	35'/40'	35'/40'	35'/40'
<b>STREET LEVEL ACTIVATION</b>							
I Transparency, Primary Street (min)					60% Residential Only Buildings: 40%		
J Transparency, Side Street (min)		25%	25%	30%	30%	30%	30%
K Pedestrian Access, Primary Street					Entrance		
<b>USES</b>							
Street Level Active Uses (min % of Primary Street frontage meeting Build-To requirement)					All C-MS and C-MX 100%		
Permitted Primary Uses					All permitted Primary Uses shall be allowed within this building form. See Div. 7.4, Uses <b>and Required Minimum Parking</b> .		
See Sections 7.3.5 - 7.3.7 for Supplemental Design Standards, Design Standard Alternatives and Design Standard Exceptions							

### 7.3.7.2 Setback Exceptions - Architectural, Site, Service & Utility Elements

**A. Intent**

To allow minor elements to encroach into a setback while maintaining an open and unobstructed minimum setback.

**B. Standard**

Except as specifically allowed below, Setbacks specified in the applicable Building Form tables shall be open and unobstructed.

**C. Exceptions**

The following Structures or portions of Structures are permitted to encroach into the Setbacks subject to the limitations in the tables below. No portion of a Structure that encroaches into the Setbacks shall extend into a required Setback beyond the maximum Setback encroachment distance specified in the tables below, as measured perpendicular to the respective Zone Lot line. Where more than one Setback encroachment is allowed for the same Structure or portion of a Structure, the permitted Setback encroachment distances shall not be cumulative. See "Height Exceptions" for encroachments related to Upper Story Setbacks.

**1. Architectural Elements**

To allow for minor elements which add to the architectural character of buildings, while maintaining an open and unobstructed setback.

	ZONE DISTRICTS	BUILDING FORMS	PRIMARY STREET	SIDE STREET	SIDE INTERIOR	REAR
Belt Courses, sills, lintels, pilasters, pediments, cornices	All C- Zone Districts	All building forms	1.5' Cornices only: 3'	1.5' Cornices only: 3'	1.5' Cornices only: 3'; if setback is less than 5': 2'	1.5' Cornices only: 5'
Intent: To allow common, minor decorative elements which are integral to a building.	<p style="text-align: right;"><i>Not to Scale. Illustrative Only.</i></p>					
<p style="text-align: center;"><i>Illustrative only</i></p>						

**2. Site Elements**

To allow for minor screening and parking elements while maintaining an open and unobstructed setback.

	ZONE DISTRICTS	BUILDING FORMS	PRIMARY STREET	SIDE STREET	SIDE INTERIOR	REAR
Fences and Walls	See Div. 10.5 Landscaping, Fences, Walls and Screening					
Surface Parking	Not Allowed					
	ZONE DISTRICTS	BUILDING FORMS	PRIMARY STREET	SIDE STREET	SIDE INTERIOR	REAR
Off-Street Parking Area	All C- Zone Districts	Town House	Not allowed	Not allowed* (*see exception below)	Allowed	Allowed
When a Zone Lot contains two or more building forms with different permitted encroachments, the less restrictive standards shall apply: for the entire Zone Lot.		All Others	Allowed	Allowed	Allowed	Allowed
Intent: To restrict off-street parking area where it is <b>more impactful due to the number of required parking spaces.</b>	<p>Side Setback, Side Setback, Side Setback, ALLEY, Side Setback, Side Setback, Side Street Setback, Rear Setback, Allowed Encroachment, Allowed Encroachment, SIDE INTERIOR, SIDE STREET, Primary Street Setback, PRIMARY STREET, See Exception, Not to Scale. Illustrative Only.</p>					
*Exception: The minimum 5' of back out space required in Div. 10.4 shall be permitted to encroach 2.5' when the encroachment is screened from the Side Street with a Garden Wall and 1 deciduous canopy tree or planting strip.						

## DIVISION 7.4 USES ~~AND REQUIRED MINIMUM PARKING~~

### SECTION 7.4.1 APPLICABILITY

- 7.4.1.1 This Division 7.4 sets forth the land uses permitted; ~~and the~~ required zoning procedures ~~and the required minimum parking~~ for all the Urban Center Neighborhood Context zone districts.
- 7.4.1.2 Uses not listed are prohibited, unless the Zoning Administrator specifically permits the unlisted use according to Section 12.4.6, Code Interpretations and Determination of Unlisted Uses.
- 7.4.1.3 For number of primary and accessory uses permitted per Zone Lot, see Section 1.2.3.5, Number of Structures and Uses allowed per Zone Lot.

### SECTION 7.4.2 ORGANIZATION

#### 7.4.2.1 Organized by Primary, Accessory and Temporary Uses

The Use ~~and Parking~~ Table first presents all primary uses, then all accessory uses, and finally all temporary uses. Primary uses are arranged hierarchically within the table by use classification, category of primary uses, and then by specific use type. Accessory uses are organized by whether such use is accessory to a primary residential use or to a primary nonresidential use. Temporary uses are presented alphabetically ordered in the last division of the table.

#### 7.4.2.2 Primary Use Classifications, Categories & Specific Use Types

##### A. Primary Use Classifications

All primary land uses in the Use ~~and Parking~~ Table are organized into one of the following five general land use classifications:

1. Residential Uses
2. Civic, Public & Institutional Uses
3. Commercial Sales, Service & Repair Uses
4. Industrial, Manufacturing & Wholesale Uses
5. Agriculture

##### B. Primary Use Categories & Specific Use Types

Primary uses are further organized into use categories and specific use types listed under each general primary land use classification. The Use ~~and Parking~~ Table is organized into the above five general land use classifications, use categories and specific use types.

##### C. Classifications & Categories Are Mutually Exclusive

The general land use classifications and use categories listed in the Use ~~and Parking~~ Table are intended to be mutually exclusive; that is, a use classified into one use category, such as “lodging accommodations,” cannot be classified in a different use category, such as “congregate living,” unless otherwise expressly allowed by this Code.

### SECTION 7.4.3 EXPLANATION OF TABLE ABBREVIATIONS

#### 7.4.3.1 General Explanation of Table Cell Entries

In each of the table cells, the entry will indicate first whether use limitations apply to the specific use, and then separated by a hyphen, the type of zoning review required prior to establishment of the use under this Code. For example, as described in more detail below, a cell entry “L-ZPIN” means, first, the use is subject to use limitations (the “L”), and, second, that the use is subject to zoning permit review with information notice (the “ZPIN”) prior to its establishment.

### 7.4.3.2 Permitted, Limited, Not Permitted

#### A. Permitted Use - No Use Limitations Apply (“P”)

A “P” in a table cell indicates that the use is permitted in the respective zone district, and is not subject to use limitations.

#### B. Permitted Use - Subject to Use Limitations (“L”)

“L” in a table cell indicates the use is permitted in the zone district subject to compliance with the use limitations referenced in the last column of the use table (“Applicable Use Limitations”).

#### C. Uses Not Permitted (“NP”)

“NP” in a table cell indicates that the use is not permitted in the specific zone district.

### 7.4.3.3 Zoning Procedure

#### A. Use Subject to Zoning Permit Review (“ZP”)

“ZP” in a table cell indicates that the use is permitted in the respective zone district only if reviewed and approved according to the requirements in Section 12.4.1, Zoning Permit Review.

#### B. Use Subject to Zoning Permit Review with Informational Notice (“ZPIN”)

“ZPIN” in a table cell indicates that the use is permitted in the respective zone district only if reviewed and approved according to the public notice and procedural requirements in Section 12.4.2, Zoning Permit Review with Informational Notice. Such uses shall comply with any applicable use limitations noted in the last column of the use table (“Applicable Use Limitations”), as well as the review criteria stated in Section 12.4.2, Zoning Permit Review with Informational Notice.

#### C. Use Subject to Zoning Permit Review with Community Information Meeting (“ZPCIM”)

“ZPCIM” in a table cell indicates that the use is permitted in the respective zone district only if reviewed and approved according to the public notice and procedural requirements in Section 12.4.1, Zoning Permit Review. Prior to formal application, an applicant shall schedule a community information meeting and provide public notice of the community information meeting according to Section 12.3.4.6, Community Information Meeting.

#### D. Use Subject to Zoning Permit with Special Exception Review (“ZPSE”)

“ZPSE” in a table cell indicates that use is generally appropriate in the neighborhood context and zone district, yet may have the potential for limited impacts on adjacent properties or on the established character of the neighborhood context or zone district. “ZPSE” uses are subject to a Board of Adjustments public hearing according to Section 12.4.9, Zoning Permit with Special Exception Review, which grants the Board of Adjustment the authority to impose conditions on the specified use to mitigate any potential impacts. Such uses shall comply with any applicable use limitations noted in the last column of the use table (“Applicable Use Limitations”), as well as the review criteria stated in Section 12.4.9, Zoning Permit with Special Exception Review.

#### E. Uses Where More Than One Zoning Procedure Is Indicated

Where a table cell shows more than one zoning procedure applies to a use, for example “L-ZP/ZPIN”, the referenced use limitation (last table column) will indicate which zoning procedure applies in a specific case. For example, a table cell may indicate “L-ZPIN/ZPSE” for a use. This means that the ZPIN zoning procedure will apply, unless the applicable use limitation specifies the ZPSE zoning procedure is triggered (e.g., by proximity to a Protected District).

### 7.4.3.4 Enclosure of Uses

All primary, accessory and temporary uses must be established, operated and maintained within a Completely Enclosed Structure, unless otherwise specifically allowed by this Code. The Use ~~and~~ **Parking** Tables in Articles 3-9 indicate when a use may be established, operated or maintained outside a Completely Enclosed Structure by including an asterisk “\*” next to the specific use type. For example, the asterisk following the “Telecommunication Tower\*” use type in the tables indicates that a telecommunication tower land use need not be enclosed.

## SECTION 7.4.4 DISTRICT SPECIFIC STANDARDS

KEY: \* = Need Not be Enclosed P = Permitted Use without Limitations L = Permitted Use with Limitations NP = Not Permitted Use ZP = Zoning Permit Review ZPCIM = Subject to Zoning Permit Review with Community Information Meeting ZPIN = Subject to Zoning Permit Review with Informational Notice ZPSE = Subject to Zoning Permit with Special Exception Review When no ZP, ZPIN, ZPCIM, ZPSE listed = No Zoning Permit required

USE CATEGORY	SPECIFIC USE TYPE • Vehicle Parking Reqmt: # spaces per unit of measurement • Bicycle Parking Reqmt Requirement: # spaces per unit of measurement (% Required Spaces in Enclosed Facility / % Required Spaces in Fixed Facility)	C-MX-3 C-MX-5 C-MX-8 C-RX-5 C-RX-8 C-RX-12	C-MX-12 C-MX-16 C-MX-20	C-MS-5 C-MS-8 C-MS-12	C-CCN-3 C-CCN-4 C-CCN-5 C-CCN-7 C-CCN-8 C-CCN-12	APPLICABLE USE LIMITATIONS
<b>RESIDENTIAL PRIMARY USE CLASSIFICATION</b>						
Household Living	Dwelling, Single Unit • No Parking Requirements	L-ZP	L-ZP	L-ZP	L-ZP	§11.2.7
	Dwelling, Two Unit • Vehicle - CCN districts only: 1/unit • Vehicle: 0.75/unit • Bicycle: No requirement	L-ZP	L-ZP	L-ZP	L-ZP	§11.2.2; §11.2.7
	Dwelling, Multi-Unit • Vehicle - CCN districts only: 1/unit • Vehicle: 0.75/unit • Bicycle: 1/2 units (80/20)	L-ZP	L-ZP	L-ZP	L-ZP	§11.2.3; §11.2.7
	Dwelling, Live / Work • Vehicle - CCN districts only: 1/unit • Vehicle: 0.75/unit • Bicycle: 1/2 units (80/20)	L-ZP	L-ZP	L-ZP	L-ZP	§11.2.4; §11.2.7
	Manufactured Home Community	NP	NP	NP	NP	
Residential Care	Residential Care, Type 1 • Vehicle: .25/1,000 sf GFA • Bicycle: No requirement	L/L-ZP	L/L-ZP	L/L-ZP	L/L-ZP	§11.2.8; §11.2.9
	Residential Care, Type 2 • Vehicle: .25/1,000 sf GFA • Bicycle: No requirement	L-ZP	L-ZP	L-ZP	L-ZP	§11.2.8; §11.2.10
	Residential Care, Type 3 • Vehicle: .25/1,000 sf GFA • Bicycle: No requirement	L-ZPCIM	L-ZPCIM	L-ZPCIM	L-ZPCIM	§11.2.8; §11.2.11
	Residential Care, Type 4 • Vehicle: .25/1,000 sf GFA • Bicycle: No requirement	C-RX-5: NP C-RX-8, -12: L- ZPCIM	L-ZPCIM	L-ZPCIM	L-ZPCIM	§11.2.8; §11.2.12
Congregate Living	All Types • Vehicle: .5/1,000 sf GFA • Bicycle: 1/20,000 sf GFA	P-ZP	P-ZP	P-ZP	P-ZP	
<b>CIVIC, PUBLIC &amp; INSTITUTIONAL PRIMARY USE CLASSIFICATION</b>						
Basic Utilities	Utility, Major Impact* • Vehicle: .5 / 1,000 sf GFA • Bicycle: No requirement	L-ZPSE	L-ZPSE	L-ZPSE	L-ZPSE	§ 11.3.1
	Utility, Minor Impact* • Vehicle: .5 / 1,000 sf GFA • Bicycle: No requirement	L-ZP	L-ZP	L-ZP	L-ZP	§ 11.3.2

**Modernizing Parking Requirements**  
**LUTI Committee Review Draft**  
**May 13, 2025**

Article 7. Urban Center Neighborhood Context  
 Division 7.4 Uses ~~and Required Minimum Parking~~

KEY: \* = Need Not be Enclosed P = Permitted Use without Limitations L = Permitted Use with Limitations NP = Not Permitted Use ZP = Zoning Permit Review  
 ZPCIM = Subject to Zoning Permit Review with Community Information Meeting ZPIN = Subject to Zoning Permit Review with Informational Notice  
 ZPSE = Subject to Zoning Permit with Special Exception Review When no ZP, ZPIN, ZPCIM, ZPSE listed = No Zoning Permit required

USE CATEGORY	SPECIFIC USE TYPE <ul style="list-style-type: none"> <li>• <del>Vehicle Parking Reqmt: # spaces per unit of measurement</del></li> <li>• <del>Bicycle Parking Reqmt Requirement: # spaces per unit of measurement (% Required Spaces in Enclosed Facility / % Required Spaces in Fixed Facility)</del></li> </ul>	C-MX-3 C-MX-5 C-MX-8 C-MX-12 C-MX-16 C-MX-20				C-CCN-3 C-CCN-4 C-CCN-5 C-CCN-7 C-CCN-8 C-CCN-12	APPLICABLE USE LIMITATIONS
		C-RX-5 C-RX-8 C-RX-12	C-MS-5 C-MS-8 C-MS-12				
Community/ Public Services	Community Center* <ul style="list-style-type: none"> <li>• <del>Vehicle: No requirement</del></li> <li>• <del>Bicycle: 1/10,000 sf GFA (0/100)</del></li> </ul>	L-ZP	L-ZP	L-ZP	L-ZP	§ 11.3.3	
	Day Care Center <ul style="list-style-type: none"> <li>• <del>Vehicle: 1/1,000 sf GFA</del></li> <li>• <del>Bicycle: 1/10,000 sf GFA (0/100)</del></li> </ul>	P-ZP	P-ZP	P-ZP	P-ZP		
	Postal Facility, Neighborhood <ul style="list-style-type: none"> <li>• <del>Vehicle – CCN districts only: 2.5/1,000 sf GFA</del></li> <li>• <del>Vehicle: 1.25/1,000 sf GFA</del></li> <li>• <del>Bicycle: 1/7,500 sf GFA (20/80)</del></li> </ul>	P-ZP	P-ZP	P-ZP	P-ZP		
Community/ Public Services	Postal Processing Center <ul style="list-style-type: none"> <li>• <del>Vehicle: 1/1,000 sf GFA</del></li> <li>• <del>Bicycle: 1/7,500 sf GFA (20/80)</del></li> </ul>	NP	P-ZP	P-ZP	NP		
	Public Safety Facility <ul style="list-style-type: none"> <li>• <del>Vehicle: 1/1,000 sf GFA</del></li> <li>• <del>Bicycle: 1/10,000 sf GFA (0/100)</del></li> </ul>	L-ZP	P-ZP	P-ZP	P-ZP	§ 11.3.5	
	Hospital	NP	NP	NP	NP		
	Correctional Institution	NP	NP	NP	NP		
Cultural/Special Purpose/ Public Parks & Open Space	Cemetery*	NP	NP	NP	NP		
	Library <ul style="list-style-type: none"> <li>• <del>Vehicle: 1/1,000 sf GFA</del></li> <li>• <del>Bicycle: 1/10,000 sf GFA (0/100)</del></li> </ul>	P-ZP	P-ZP	P-ZP	P-ZP		
	Museum <ul style="list-style-type: none"> <li>• <del>Vehicle: 1/1,000 sf GFA</del></li> <li>• <del>Bicycle: 1/10,000 sf GFA (0/100)</del></li> </ul>	NP	P-ZP	P-ZP	P-ZP		
	City Park*	NP	NP	NP	NP		
	Open Space - Conservation* <ul style="list-style-type: none"> <li>• <del>No Parking Requirements</del></li> </ul>	P-ZP	P-ZP	P-ZP	P-ZP		
Education	Elementary or Secondary School <ul style="list-style-type: none"> <li>• <del>Vehicle: 1/1,000 sf GFA</del></li> <li>• <del>Bicycle: 1/10,000 sf GFA (0/100)</del></li> </ul>	L-ZP	L-ZP	L-ZP	L-ZP	§ 11.3.8	
	University or College <ul style="list-style-type: none"> <li>• <del>Vehicle: 1/1,000 sf GFA</del></li> <li>• <del>Bicycle: 1/10,000 sf GFA (0/100)</del></li> </ul>	L-ZP	L-ZP	L-ZP	L-ZP	§ 11.3.8; § 11.3.9	
	Vocational or Professional School <ul style="list-style-type: none"> <li>• <del>Vehicle: 1/1,000 sf GFA</del></li> <li>• <del>Bicycle: 1/10,000 sf GFA (0/100)</del></li> </ul>	NP	L-ZP	L-ZP	L-ZP	§ 11.3.8	
Public and Religious Assembly	All Types <ul style="list-style-type: none"> <li>• <del>Vehicle: No requirement</del></li> <li>• <del>Bicycle: 1/10,000 sf GFA (0/100)</del></li> </ul>	L-ZP	P-ZP	P-ZP	P-ZP	§ 11.3.10	



KEY: \* = Need Not be Enclosed P = Permitted Use without Limitations L = Permitted Use with Limitations NP = Not Permitted Use ZP = Zoning Permit Review ZPCIM = Subject to Zoning Permit Review with Community Information Meeting ZPIN = Subject to Zoning Permit Review with Informational Notice ZPSE = Subject to Zoning Permit with Special Exception Review When no ZP, ZPIN, ZPCIM, ZPSE listed = No Zoning Permit required

USE CATEGORY	SPECIFIC USE TYPE <ul style="list-style-type: none"> <li>• <del>Vehicle Parking Reqmt: # spaces per unit of measurement</del></li> <li>• <del>Bicycle Parking Reqmt Requirement: # spaces per unit of measurement (% Required Spaces in Enclosed Facility / % Required Spaces in Fixed Facility)</del></li> </ul>	APPLICABLE ZONING DISTRICTS				APPLICABLE USE LIMITATIONS
		C-RX-5 C-RX-8 C-RX-12	C-MX-3 C-MX-5 C-MX-8 C-MX-12 C-MX-16 C-MX-20	C-MS-5 C-MS-8 C-MS-12	C-CCN-3 C-CCN-4 C-CCN-5 C-CCN-7 C-CCN-8 C-CCN-12	
<b>COMMERCIAL SALES, SERVICES, &amp; REPAIR PRIMARY USE CLASSIFICATION</b>						
Adult Business	All Types	NP	NP	NP	NP	See Section 9.4.4, Use Overlay Districts, for adult business use allowance in the UO-1 District.
Arts, Recreation & Entertainment	Arts, Recreation and Entertainment Services, Indoor <ul style="list-style-type: none"> <li>• <del>Vehicle – Artist Studio: 0.3/1,000 sf GFA</del></li> <li>• <del>Vehicle – CCN districts only: 2.5/1,000 sf GFA</del></li> <li>• <del>Vehicle – All Others: 1.25/1,000 sf GFA</del></li> <li>• <del>Bicycle: 1/7,500 sf GFA (20/80)</del></li> </ul>	P-ZP	P-ZP	P-ZP	P-ZP	
	Arts, Recreation and Entertainment Services, Outdoor* <ul style="list-style-type: none"> <li>• <del>Vehicle – CCN districts only: 2.5/1,000 sf GFA</del></li> <li>• <del>Vehicle: 1.25/1,000 sf GFA</del></li> <li>• <del>Bicycle: 1/7,500 sf GFA (20/80)</del></li> </ul>	L-ZPIN	L-ZPSE	L-ZPSE	L-ZPIN	§ 11.4.3
	Event Space with Alternate Parking and Loading* <ul style="list-style-type: none"> <li>• <del>Vehicle: No requirement</del></li> <li>• <del>Bicycle: No requirement</del></li> </ul>	NP	NP	NP	NP	
	Sports and/or Entertainment Arena or Stadium*	NP	NP	NP	NP	
Nonresidential Uses in Existing Business Structures In Residential Zones <i>(All Uses Shall Be Parked According to the Parking Requirement Stated in this Use Table for the Specific Nonresidential Use)</i>		L-ZP	Not Applicable	Not Applicable	Not Applicable	§11.4.6
Parking of Vehicles	Parking, Garage <ul style="list-style-type: none"> <li>• <del>No Parking Requirements</del></li> </ul>	P-ZP	P-ZP	P-ZP	L-ZP	§7.3.5.2
	Parking, Surface*	NP	NP	NP	NP	
Eating & Drinking Establishments	All Types <ul style="list-style-type: none"> <li>• <del>Vehicle – MS only: 2/1,000 sf GFA</del></li> <li>• <del>Vehicle: 2.5/1,000 sf GFA</del></li> <li>• <del>Bicycle: 1/1,500 sf GFA (0/100)</del></li> </ul>	P-ZP	P-ZP	P-ZP	P-ZP	
Lodging Accommodations	Bed and Breakfast Lodging <ul style="list-style-type: none"> <li>• <del>Vehicle: 0.875/guest room or unit</del></li> <li>• <del>Bicycle: 1/7,500 sf GFA (60/40)</del></li> </ul>	P-ZP	P-ZP	P-ZP	P-ZP	
	Lodging Accommodations, All Others <ul style="list-style-type: none"> <li>• <del>Vehicle: 0.5/ guest room or unit</del></li> <li>• <del>Bicycle: 1/7,500 sf GFA (60/40)</del></li> </ul>	P-ZP	P-ZP	P-ZP	P-ZP	
Office	Dental / Medical Office or Clinic <ul style="list-style-type: none"> <li>• <del>Vehicle – CCN districts only: 2/1,000 sf GFA</del></li> <li>• <del>Vehicle: 1.25/1,000 sf GFA</del></li> <li>• <del>Bicycle: 1/7,500 sf GFA (60/40)</del></li> </ul>	L-ZP	L-ZP	L-ZP	L-ZP	§11.4.10
	Office, All Others <ul style="list-style-type: none"> <li>• <del>Vehicle – CCN districts only: 2/1,000 sf GFA</del></li> <li>• <del>Vehicle: 1.25/1,000 sf GFA</del></li> <li>• <del>Bicycle: 1/7,500 sf GFA (60/40)</del></li> </ul>	P-ZP	P-ZP	P-ZP	P-ZP	

KEY: \* = Need Not be Enclosed P = Permitted Use without Limitations L = Permitted Use with Limitations NP = Not Permitted Use ZP = Zoning Permit Review  
 ZPCIM = Subject to Zoning Permit Review with Community Information Meeting ZPIN = Subject to Zoning Permit Review with Informational Notice  
 ZPSE = Subject to Zoning Permit with Special Exception Review When no ZP, ZPIN, ZPCIM, ZPSE listed = No Zoning Permit required

USE CATEGORY	SPECIFIC USE TYPE <ul style="list-style-type: none"> <li>• <del>Vehicle Parking Reqmt: # spaces per unit of measurement</del></li> <li>• <del>Bicycle Parking Reqmt Requirement: # spaces per unit of measurement (% Required Spaces in Enclosed Facility / % Required Spaces in Fixed Facility)</del></li> </ul>	C-MX-3 C-MX-5 C-MX-8 C-RX-5 C-RX-8 C-RX-12				C-MS-5 C-MS-8 C-MS-12		C-CCN-3 C-CCN-4 C-CCN-5 C-CCN-7 C-CCN-8 C-CCN-12	
Retail Sales, Service & Repair (Not Including Vehicle or Equipment Sales, Service & Repair)	Animal Sales and Services, Household Pets Only <ul style="list-style-type: none"> <li>• <del>Vehicle – CCN districts only: 2.5/1,000 sf GFA</del></li> <li>• <del>Vehicle: 1.25/1,000 sf GFA</del></li> <li>• <del>Bicycle: 1/7,500 sf GFA (20/80)</del></li> </ul>	L-ZP	L-ZP	L-ZP	L-ZP				\$11.4.12
	Animal Sales and Services, All Others	NP	NP	NP	NP				
	Food Sales or Market <ul style="list-style-type: none"> <li>• <del>Vehicle – CCN districts only: 2.5/1,000 sf GFA</del></li> <li>• <del>Vehicle: 1.25/1,000 sf GFA</del></li> <li>• <del>Bicycle: 1/7,500 sf GFA (20/80)</del></li> </ul>	L-ZP	P-ZP	P-ZP	P-ZP				\$11.4.14
	Pawn Shop	NP	NP	NP	NP				
	Retail Sales, Service & Repair -- Outdoor*	NP	NP	NP	NP				
	Retail Sales, Service & Repair - Firearms Sales <ul style="list-style-type: none"> <li>• <del>Vehicle: 1.25/1,000 sf GFA</del></li> <li>• <del>Bicycle: 1/7,500 sf GFA (20/80)</del></li> </ul>	NP	NP	P-ZP	NP				
Retail Sales, Service & Repair, All Others <ul style="list-style-type: none"> <li>• <del>Vehicle – CCN districts only: 2.5/1,000 sf GFA</del></li> <li>• <del>Vehicle: 1.25/1,000 sf GFA</del></li> <li>• <del>Bicycle: 1/7,500 sf GFA (20/80)</del></li> </ul>	P-ZP	P-ZP	P-ZP	P-ZP					
Vehicle / Equipment Sales, Rentals, Service & Repair	Automobile Emissions Inspection Facility	NP	NP	NP	NP				
	Automobile Services, Light <ul style="list-style-type: none"> <li>• <del>Vehicle: .5/1,000 sf GFA</del></li> <li>• <del>Bicycle: No requirement</del></li> </ul>	NP	L-ZP	L-ZP	L-ZP			\$11.4.18 \$11.4.19	
	Automobile Services, Heavy <ul style="list-style-type: none"> <li>• <del>Vehicle: .5/1,000 sf GFA</del></li> <li>• <del>Bicycle: No requirement</del></li> </ul>	NP	NP	L-ZP/ZPSE	NP			\$11.4.18 \$11.4.20	
	Automobile / Motorcycle / Light Truck Sales, Rentals, Leasing; Pawn Lot or Vehicle Auctioneer* <ul style="list-style-type: none"> <li>• <del>Vehicle: .5/1,000 sf GFA</del></li> <li>• <del>Bicycle: No requirement</del></li> </ul>	L-ZP	L-ZP	L-ZP	L-ZP			\$11.4.21	
	Heavy Vehicle/ Equipment Sales, Rentals & Service*	NP	NP	NP	NP				

KEY: \* = Need Not be Enclosed P = Permitted Use without Limitations L = Permitted Use with Limitations NP = Not Permitted Use ZP = Zoning Permit Review ZPCIM = Subject to Zoning Permit Review with Community Information Meeting ZPIN = Subject to Zoning Permit Review with Informational Notice ZPSE = Subject to Zoning Permit with Special Exception Review When no ZP, ZPIN, ZPCIM, ZPSE listed = No Zoning Permit required

USE CATEGORY	SPECIFIC USE TYPE • <del>Vehicle Parking Reqmt: # spaces per unit of measurement</del> • <del>Bicycle Parking Reqmt Requirement: # spaces per unit of measurement (% Required Spaces in Enclosed Facility / % Required Spaces in Fixed Facility)</del>	APPLICABLE USE LIMITATIONS				
		C-MX-3 C-MX-5 C-MX-8 C-RX-5 C-RX-8 C-RX-12	C-MX-12 C-MX-16 C-MX-20	C-MS-5 C-MS-8 C-MS-12	C-CCN-3 C-CCN-4 C-CCN-5 C-CCN-7 C-CCN-8 C-CCN-12	
<b>INDUSTRIAL, MANUFACTURING &amp; WHOLESALE PRIMARY USE CLASSIFICATION</b>						
Communications and Information	Antennas Not Attached to a Tower* • <del>No Parking Requirements</del>	L-ZP	L-ZP	L-ZP	L-ZP	\$11.5.2
	Communication Services • <del>Vehicle: .5 / 1,000 sf GFA</del> • <del>Bicycle: No requirement</del>	P-ZP	C-MX-3: L-ZP/ZPSE All Others: P-ZP	P-ZP	P-ZP	\$11.5.1
	Telecommunications Towers* • <del>No Parking Requirements</del>	L-ZP/ZPIN/ ZPSE	L-ZP/ZPIN/ ZPSE	L-ZP/ ZPIN/ ZPSE	L-ZP/ ZPIN/ ZPSE	\$11.5.2
	Telecommunications Tower - Alternative Structure* • <del>No Parking Requirements</del>	L-ZP/ZPIN	L-ZP/ZPIN	L-ZP/ZPIN	L-ZP/ZPIN	\$11.5.2
	Telecommunication Facilities -- All Others* • <del>No Parking Requirements</del>	L-ZPIN	L-ZPIN	L-ZPIN	L-ZPIN	\$11.5.2
Industrial Services	Contractors, Special Trade - General • <del>Vehicle: .5 / 1,000 sf GFA</del> • <del>Bicycle: No requirement</del>	NP	L-ZP	L-ZP	NP	\$11.5.3
	Contractors, Special Trade - Heavy/ Contractor Yard*	NP	NP	NP	NP	
	Food Preparation and Sales, Commercial • <del>Vehicle: .5 / 1,000 sf GFA</del> • <del>Bicycle: No requirement</del>	NP	L-ZP	L-ZP	L-ZP	\$11.5.5
	Laboratory, Research, Development and Technological Services • <del>Vehicle: .5 / 1,000 sf GFA</del> • <del>Bicycle: No requirement</del>	NP	L-ZP	L-ZP	NP	\$11.5.6
	Service/Repair, Commercial • <del>Vehicle: .5 / 1,000 sf GFA</del> • <del>Bicycle: No requirement</del>	NP	L-ZP	L-ZP	NP	\$11.5.7
Manufacturing and Production	Manufacturing, Fabrication & Assembly -- Custom • <del>Vehicle: .5 / 1,000 sf GFA</del> • <del>Bicycle: No requirement</del>	L-ZPIN	L-ZP	L-ZP	L-ZP	\$11.5.8
	Manufacturing, Fabrication & Assembly -- General	NP	NP	NP	NP	
	Manufacturing, Fabrication & Assembly -- Heavy	NP	NP	NP	NP	
Mining & Extraction and Energy Producing Systems	Oil, Gas -- Production, Drilling* Sand or Gravel Quarry*	NP	NP	NP	NP	
	Wind Energy Conversion Systems* • <del>No Parking Requirements</del>	L-ZPIN/ ZPSE	L-ZPIN/ ZPSE	L-ZPIN/ ZPSE	L-ZPIN/ ZPSE	\$11.5.13

**Modernizing Parking Requirements**  
**LUTI Committee Review Draft**  
**May 13, 2025**

Article 7. Urban Center Neighborhood Context  
 Division 7.4 Uses and Required Minimum Parking

KEY: \* = Need Not be Enclosed P = Permitted Use without Limitations L = Permitted Use with Limitations NP = Not Permitted Use ZP = Zoning Permit Review ZPCIM = Subject to Zoning Permit Review with Community Information Meeting ZPIN = Subject to Zoning Permit Review with Informational Notice ZPSE = Subject to Zoning Permit with Special Exception Review When no ZP, ZPIN, ZPCIM, ZPSE listed = No Zoning Permit required

USE CATEGORY	SPECIFIC USE TYPE <ul style="list-style-type: none"> <li>• <del>Vehicle Parking Reqmt: # spaces per unit of measurement</del></li> <li>• <del>Bicycle Parking Reqmt Requirement: # spaces per unit of measurement (% Required Spaces in Enclosed Facility / % Required Spaces in Fixed Facility)</del></li> </ul>					APPLICABLE USE LIMITATIONS
		C-RX-5 C-RX-8 C-RX-12	C-MX-3 C-MX-5 C-MX-8 C-MX-12 C-MX-16 C-MX-20	C-MS-5 C-MS-8 C-MS-12	C-CCN-3 C-CCN-4 C-CCN-5 C-CCN-7 C-CCN-8 C-CCN-12	
Transportation Facilities	Airport*	NP	NP	NP	NP	
	Helipad, Helistop, Heliport* • <del>No Parking Requirements</del>	L-ZPIN	L-ZP	L-ZP	NP	§11.5.14
	Railroad Facilities*	NP	NP	NP	NP	
	Railway Right-of-Way* • <del>No Parking Requirements</del>	P-ZP	P-ZP	P-ZP	P-ZP	
	Terminal, Station or Service Facility for Passenger Transit System • <del>Vehicle: .5/1,000-sf-GFA</del> • <del>Bicycle: No requirement</del>	P-ZP	P-ZP	P-ZP	P-ZP	
	Terminal, Freight, Air Courier Services	NP	NP	NP	NP	
Waste Related Services	Automobile Parts Recycling Business*	NP	NP	NP	NP	
	Junkyard*	NP	NP	NP	NP	
	Recycling Center	NP	NP	NP	NP	
	Recycling Collection Station	NP	NP	NP	NP	
	Recycling Plant, Scrap Processor	NP	NP	NP	NP	
Wholesale, Storage, Warehouse & Distribution	Solid Waste Facility	NP	NP	NP	NP	
	Automobile Towing Service Storage Yard*	NP	NP	NP	NP	
	Mini-storage Facility • <del>Vehicle: 0.1/1,000-sf-GFA</del> • <del>Bicycle: No requirement</del>	NP	L-ZP	NP	NP	§11.5.23
	Vehicle Storage, Commercial*	NP	NP	NP	NP	
	Wholesale Trade or Storage, General	NP	NP	NP	NP	
Wholesale Trade or Storage, Light • <del>Vehicle: .5/1,000-sf-GFA</del> • <del>Bicycle: No requirement</del>	NP	L-ZP/ZPIN/ ZPSE	L-ZP/ ZPIN/ ZPSE	NP	§11.5.26	
<b>AGRICULTURE PRIMARY USE CLASSIFICATION</b>						
Agriculture	Aquaculture*	NP	NP	NP	NP	
	Garden, Urban* • <del>Vehicle: .5/1,000-sf-GFA</del> • <del>Bicycle: No requirement</del>	L-ZP	L-ZP	L-ZP	L-ZP	§ 11.6.2
	Husbandry, Animal*	NP	NP	NP	NP	
	Husbandry, Plant* • <del>Vehicle: .5/1,000-sf-GFA</del> • <del>Bicycle: No requirement</del>	L-ZP	L-ZP	L-ZP	L-ZP	§ 11.6.5

KEY: \* = Need Not be Enclosed P = Permitted Use without Limitations L = Permitted Use with Limitations NP = Not Permitted Use ZP = Zoning Permit Review ZPCIM = Subject to Zoning Permit Review with Community Information Meeting ZPIN = Subject to Zoning Permit Review with Informational Notice ZPSE = Subject to Zoning Permit with Special Exception Review When no ZP, ZPIN, ZPCIM, ZPSE listed = No Zoning Permit required

USE CATEGORY	SPECIFIC USE TYPE					APPLICABLE USE LIMITATIONS
	<ul style="list-style-type: none"> <li>• Vehicle Parking Reqmt: # spaces per unit of measurement</li> <li>• Bicycle Parking Reqmt Requirement: # spaces per unit of measurement (% Required Spaces in Enclosed Facility / % Required Spaces in Fixed Facility)</li> </ul>	C-MX-3	C-MX-5	C-MX-8	C-CCN-3	C-CCN-4
		C-RX-5	C-MX-12	C-MS-5	C-CCN-7	C-CCN-8
		C-RX-8	C-MX-16	C-MS-8	C-CCN-8	C-CCN-12
		C-RX-12	C-MX-20	C-MS-12	C-CCN-12	
ACCESSORY TO PRIMARY RESIDENTIAL USES USE CLASSIFICATION						
Accessory to Primary Residential Uses  (Parking is Not Required for Accessory Uses Unless Specifically Stated in this Table or in an Applicable Use Limitation)	Unlisted Accessory Uses	L - Applicable to all Zone Districts				§11.7
	Accessory Dwelling Unit	L-ZP	L-ZP	L-ZP	L-ZP	§11.7; §11.8.2
	Domestic Employee	L	L	L	L	§11.7; §11.8.3
	Garden*	L	L	L	L	§11.7; §11.8.4
	Keeping of Household Animals*	L/L-ZPIN	L/L-ZPIN	L/L-ZPIN	L/L-ZPIN	§11.7; §11.8.5
	Keeping and Off-Street Parking of Vehicles, Motorcycles, Trailers & Recreational Vehicles*	L	L	L	L	§11.7; §10.9
	Kennel or Exercise Run*	L	L	L	L	§11.7; §11.8.6
	Limited Commercial Sales, Services Accessory to Multi-Unit Dwelling Use	L-ZP	Not Applicable - See Permitted Primary Uses			§11.7; §11.8.7
	Outdoor Storage, Residential*	L	L	L	L	§11.7; §11.8.8
	Second Kitchen Accessory to Single Unit Dwelling Use	NP	NP	NP	NP	
	Short-term Rental	L	L	L	L	§11.7; §11.8.10
	Vehicle Storage, Repair and Maintenance*	L	L	L	L	§11.7; §10.9
Wind Energy Conversion Systems*	L-ZPIN/ ZPSE	Not Applicable - See Permitted Primary Uses			§11.7; §11.5.13	
Yard and/or Garage Sales*	L	L	L	L	§11.7; §11.8.11	
HOME OCCUPATIONS ACCESSORY TO PRIMARY RESIDENTIAL USES USE CLASSIFICATION						
Home Occupations  (Parking is Not Required for Home Occupations Unless Specifically Stated in this Table or in an Applicable Use Limitations)	Child Care Home, Large	L-ZP	L-ZP	L-ZP	L-ZP	§11.9; §11.9.3
	All Other Types	L-ZP	L-ZP	L-ZP	L-ZP	§11.9; §11.9.4
	Unlisted Home Occupations	L-ZPIN	L-ZPIN	L-ZPIN	L-ZPIN	§11.9; §11.9.5

KEY: \* = Need Not be Enclosed P = Permitted Use without Limitations L = Permitted Use with Limitations NP = Not Permitted Use ZP = Zoning Permit Review ZPCIM = Subject to Zoning Permit Review with Community Information Meeting ZPIN = Subject to Zoning Permit Review with Informational Notice ZPSE = Subject to Zoning Permit with Special Exception Review When no ZP, ZPIN, ZPCIM, ZPSE listed = No Zoning Permit required

USE CATEGORY	SPECIFIC USE TYPE	APPLICABLE USE LIMITATIONS								
	<ul style="list-style-type: none"> <li>• <del>Vehicle Parking Reqmt: # spaces per unit of measurement</del></li> <li>• <del>Bicycle Parking Reqmt Requirement: # spaces per unit of measurement (% Required Spaces in Enclosed Facility / % Required Spaces in Fixed Facility)</del></li> </ul>	C-MX-3	C-MX-5	C-MX-8	C-CCN-3	C-CCN-4	C-CCN-5	C-CCN-7	C-CCN-8	C-CCN-12
		C-RX-5	C-MX-12	C-MS-5	C-CCN-7	C-CCN-8	C-CCN-12			
		C-RX-8	C-MX-16	C-MS-8	C-CCN-8					
		C-RX-12	C-MX-20	C-MS-12	C-CCN-12					

**ACCESSORY TO PRIMARY NONRESIDENTIAL USES USE CLASSIFICATION**

USE CATEGORY	SPECIFIC USE TYPE	APPLICABLE USE LIMITATIONS				APPLICABLE USE LIMITATIONS
		NP	L-ZP	L-ZP	L-ZP	
Accessory to Primary Non-residential Uses  (Parking is Not Required for Accessory Uses Unless Specifically Stated in this Table or in an Applicable Use Limitation)	Unlisted Accessory Uses	L - Applicable to all Zone Districts				\$11.7; 11.10.1
	Amusement Devices Accessory to Eating/Drinking Establishments, College/University and Theater Uses	NP	L-ZP	L-ZP	L-ZP	\$11.7; §11.10.2
	Automobile Rental Services Accessory to Certain Retail Uses*	Not Applicable - See Permitted Primary Uses	Not Applicable - See Permitted Primary Uses	Not Applicable - See Permitted Primary Uses	NP	\$11.7; §11.10.3
	Book or gift store; media recording and production facilities accessory to public libraries, museums, places of religious assembly, colleges or universities	Not Applicable - See Permitted Primary Uses				\$11.7; §11.10.4
	Car Wash Bay Accessory to Automobile Services or Hotel Uses	NP	NP	NP	NP	
	College accessory to a Place for Religious Assembly	Not Applicable - See Permitted Primary Uses				\$11.7; §11.10.6
	Conference Facilities Accessory to Hotel Use	NP	L	L	NP	\$11.7; §11.10.7
	Drive Through Facility Accessory to Eating/Drinking Establishments and to Retail Sales, Service, and Repair Uses*	NP	L-ZP	L-ZP	NP	\$11.7; §11.10.8
	Emergency Vehicle Access Point	NP	NP	NP	NP	
	Garden*	L	L	L	L	\$11.7; §11.10.10
	Keeping of Animals	L/L-ZPIN	L/L-ZP/L-ZPIN	L/L-ZP/L-ZPIN	L/L-ZP/L-ZPIN	\$11.7; § 11.10.11
	Limited Commercial Sales, Services	L	L	L	L	\$11.7; §11.10.12
	Nonresidential Uses in Existing Business Structures In Residential Zones - Accessory Uses	Not Applicable - See Permitted Primary Uses	Not Applicable			\$11.7; §11.4.6
	Occasional Sales, Services Accessory to Primary Places of Religious Assembly or Primary Uses Operated by Nonprofit Organizations*	L	L	L	L	\$11.7; §11.10.13
	Outdoor Gathering Area*	L/L-ZP/L-ZPIN	L/L-ZP/L-ZPIN	L/L-ZP/L-ZPIN	L/L-ZP/L-ZPIN	\$11.7; §11.10.14
	Outdoor Entertainment Accessory to an Eating/Drinking Establishment Use*	L-ZPIN/ZPSE	L-ZPIN/ZPSE	L-ZPIN/ZPSE	L-ZPIN/ZPSE	\$11.7; §11.10.15
	Outdoor Retail Sale and Display*	NP	L-ZP	L-ZP/ZPSE	L-ZP/ZPSE	\$11.7; §11.10.16
	Outdoor Storage, General*	NP	NP	NP	NP	
	Outdoor Storage, Limited*	NP	L	L	L	\$11.7; §11.10.18
	Rental or Sales of Adult Material Accessory to a Permitted Bookstore Retail Sales Use	L	L	L	L	\$11.7; §11.10.20
Retail Food Establishment, Mobile (Food Truck)*	L-ZP	L-ZP	L-ZP	L-ZP	\$11.7; §11.10.19	

KEY: \* = Need Not be Enclosed P = Permitted Use without Limitations L = Permitted Use with Limitations NP = Not Permitted Use ZP = Zoning Permit Review  
 ZPCIM = Subject to Zoning Permit Review with Community Information Meeting ZPIN = Subject to Zoning Permit Review with Informational Notice  
 ZPSE = Subject to Zoning Permit with Special Exception Review When no ZP, ZPIN, ZPCIM, ZPSE listed = No Zoning Permit required

USE CATEGORY	SPECIFIC USE TYPE	APPLICABLE USE LIMITATIONS			
	<ul style="list-style-type: none"> <li>• <del>Vehicle Parking Reqmt- # spaces per unit of measurement</del></li> <li>• <del>Bicycle Parking Reqmt Requirement- # spaces per unit of measurement (% Required Spaces in Enclosed Facility / % Required Spaces in Fixed Facility)</del></li> </ul>	C-MX-3	C-CCN-3		
		C-MX-5	C-CCN-4		
		C-MX-8	C-CCN-5		
		C-RX-5	C-MX-12	C-MS-5	C-CCN-7
		C-RX-8	C-MX-16	C-MS-8	C-CCN-8
		C-RX-12	C-MX-20	C-MS-12	C-CCN-12

**TEMPORARY USE CLASSIFICATION**

Temporary Uses  (Parking is Not Required for Temporary Uses Unless Specifically Stated in this Table or in an Applicable Use Limitations)	Unlisted Temporary Uses	L - Applicable to all Zone Districts				§11.11.1
	Ambulance Service - Temporary	L-ZP	Not Applicable - See Permitted Primary Uses			§11.11.2
	Amusement / Entertainment - Temporary*	NP	NP	NP	NP	
	Bazaar, Carnival, Circus or Special Event*	L-ZP	L-ZP	L-ZP	L-ZP	§11.11.4
	Building or yard for construction materials*	L-ZP	L-ZP	L-ZP	L-ZP	§11.11.5
	Concrete, Asphalt, and Rock Crushing Facility*	L-ZP	L-ZP	L-ZP	L-ZP	§11.11.6
	Fence for Demolition or Construction Work	L-ZP	L-ZP	L-ZP	L-ZP	§11.11.7
	Health Care Center	L-ZP	P-ZP	P-ZP	P-ZP	§11.11.8
	Noncommercial Concrete Batching Plant*	L-ZP	L-ZP	L-ZP	L-ZP	§11.11.9
	Outdoor Retail Sales - Pedestrian / Transit Mall*	NP	NP	NP	NP	
	Outdoor Retail Sales*	L-ZP	L-ZP	NP	L-ZP	§11.11.11
	Outdoor Sales, Seasonal*	L-ZPIN	L-ZP	L-ZP	L-ZP	§11.11.12
	Parking Lot Designated for a Special Event*	L-ZP	L-ZP	L-ZP	L-ZP	§11.11.13
	Retail Food Establishment, Mobile (Food Truck)*	NP	L/L-ZP	NP	L/L-ZP	§11.11.14
	Temporary Construction Office	L-ZP	L-ZP	L-ZP	NP	§11.11.15
	Temporary Office - Real Estate Sales	L-ZP	L-ZP	L-ZP	NP	§11.11.16
	Temporary Managed Community*	L-ZPCIM	L-ZPCIM	L-ZPCIM	L-ZPCIM	§11.11.17
Tent for Religious Services	NP	NP	NP	NP		

## DIVISION 8.3 DOWNTOWN CORE AND DOWNTOWN THEATER DISTRICTS (D-C, D-TD)

### SECTION 8.3.1 DOWNTOWN CORE AND DOWNTOWN THEATER DISTRICTS

#### 8.3.1.1 Generally

The provisions of this Division apply to all lands, uses and structures in the Downtown Core and Downtown Theater districts.

#### 8.3.1.2 Uses Permitted

See Division 8.11, Uses ~~and Minimum/Maximum Parking Requirements~~, for uses permitted in the Downtown Core and Downtown Theater Districts.

#### 8.3.1.3 Required Downtown Ground Floor Active Uses

In portions of new buildings and outdoor areas along or within 30 feet of the 16th Street pedestrian and transit mall, and in portions of existing buildings and outdoor areas within 30 feet of the 16th Street pedestrian and transit mall that are renovated and where the renovation includes all or a part of the leasable ground floor areas of the building, at least 65 percent of the linear frontage of the property along the 16th Street pedestrian and transit mall shall be occupied by Downtown Ground Floor Active Uses.

#### 8.3.1.4 Permitted Structures

##### A. Open Space Required

For each structure designed, used or occupied either in whole or in part as a multiple unit dwelling, there shall be provided a minimum of 30 square feet of unobstructed open space for each dwelling unit; such unobstructed open space may be located on the ground or on several usable roofs or balconies, but shall not include space provided for off-street parking; provided however such requirement shall not apply to any structure converted from nonresidential to residential uses.

##### B. Minimum and Maximum Heights

1. **Minimum Heights:** The minimum height of structures shall be 2 stories or 30 feet.
2. **Maximum Heights:** The maximum heights of buildings are not limited except in the following height areas as shown on Exhibit 8.1:
  - a. Sunlight Preservation Area 1: See Subsection 8.3.1.4.C. below.
  - b. Height Area 1: 200 feet
  - c. Height Area 2: 400 feet



### 8.3.1.5 Off-Street Parking Requirements

#### A. ~~Applicable Standards~~

~~The general off-street parking standards in Division 10.4, Parking and Loading, of this Code shall apply in the D-C and D-TD and D-CV zone districts, except where the standards stated in this Section 8.3.1.5 conflict, in which case the standards in this Section 8.3.1.5 shall apply.~~

#### B. ~~Amount of Parking Spaces Required~~

- ~~There shall be no minimum off-street parking requirement for any use in the D-C or D-TD or D-CV zone districts.~~
- ~~Parking spaces provided in a parking structure to serve office uses in the D-C or D-TD or D-CV zone districts shall comply with the use limitations applicable to a “parking, garage” use stated in Section 11.4.7.1.~~

#### C. ~~Accessible Parking~~

~~Whenever off-street parking spaces are provided, a minimum number of accessible parking spaces shall be provided according to the requirements of the Denver Building Code and the federal Americans with Disabilities Act.~~

#### D. ~~Bicycle Parking~~

~~The following standard shall apply instead of the general bicycle parking standards in Article 10, Division 10.4, Parking and Loading.~~

- ~~All new parking structures shall contain at least 1 designated bicycle parking space for each 20 automobile parking spaces, provided, however, that in no event shall any new parking structure be required to contain more than 50 bicycle parking spaces.~~

### 8.3.1.6 Design Requirements

#### A. ~~Downtown Ground Floor Active Use Street Frontages~~

- ~~New buildings or renovations of existing buildings in which the renovation includes all or part of the leasable ground floor areas of the building shall be designed and constructed to accommodate Downtown Ground Floor Active Uses for at least 65 percent of the linear frontage along the following streets: 16th Street pedestrian and transit mall, Larimer Street, Curtis Street, Tremont Place, Cleveland Place, and any light rail line operating in a street or fixed-guideway transit line operating in a street.~~
- ~~Street-facing ground floors of new buildings on named or numbered streets not included in the paragraph above shall provide 60 to 90 percent transparency as measured from floor to floor for at least 65 percent of the linear frontage of the building,~~
- ~~In all cases, transparent glass shall possess a minimum .65 light transmission factor.~~

#### B. ~~Minimum Build-to Requirements~~

- ~~Within the area bounded by the centerlines of 14th Street, 18th Street, Broadway and Colfax and the Larimer/Market Street alley: Buildings shall be built-to or within 10 feet of the property line adjoining the street for no less than 65% of each separately owned zone lot frontage, except along the Southwest side of the 16th Street Mall where the build-to zone shall be increased to 20 feet.~~
- ~~In the areas northeast and southwest of the area noted above in Subsection B.1, buildings shall be built to within 10 feet of the property line adjoining the street for no less than 50% of each separately owned zone lot frontage.~~

## DIVISION 8.4 LOWER DOWNTOWN DISTRICT (D-LD)

### SECTION 8.4.1 LOWER DOWNTOWN DISTRICT

#### 8.4.1.1 General

The provisions of this Division apply to all lands, uses and structures in the D-LD District.

#### 8.4.1.2 Description of District

The district is intended to provide for and encourage the preservation and vitality of older areas that are significant because of their architectural, historical and economic value. A variety of land uses will be permitted in order to facilitate the reuse of existing structures without jeopardizing or reducing zoning standards promoting the public safety, convenience, health, general welfare and the preservation of the comprehensive plan. New residential development is encouraged. The design of new structures should recognize the style and character of adjoining building exteriors, i.e., cornice lines and building materials and colors should be similar wherever possible.

#### 8.4.1.3 Applicable Rules and Standards

##### A. DRMC Chapter 30 Applies

All new development, including construction or alteration of buildings and structures, shall comply with the standards stated in DRMC, Chapter 30.

##### B. DZC Building Form Standards Do Not Apply

New development, including construction or alteration of buildings and structures, is exempt from application of the primary and detached accessory building form standards in this Code.

##### C. DZC General Development Standards Apply

All development in the D-LD Zone District shall comply with applicable general development and design standards stated in DZC, Article 10, General Design Standards.

##### D. Uses Permitted

See Division 8.11, Uses ~~and Minimum/Maximum Parking Requirements~~ for all uses permitted, including any applicable use limitations, in the D-LD District.

#### 8.4.1.4 ~~Off-Street Parking Requirements~~

##### A. ~~Applicable Standards~~

~~All development in the D-LD zone district shall comply with the off-street vehicle parking standards and the bicycle parking standards in Division 10.4, Parking and Loading, of this Code except where the standards stated in this Section 8.4.1.4 conflict, in which case the standards in this Section 8.4.1.4 shall apply in the D-LD zone district.~~

##### B. ~~Amount of Parking Spaces Required~~

~~There shall be no minimum off-street parking requirement for any use in the D-LD zone district.~~

##### C. ~~Accessible Parking~~

~~Whenever off-street parking spaces are provided, a minimum number of accessible parking spaces shall be provided according to the requirements of the Denver Building Code and the federal Americans with Disabilities Act.~~

## SECTION 8.6.3 BUILDING FORM STANDARDS FOR PRIMARY STRUCTURES FOR DOWNTOWN GOLDEN TRIANGLE DISTRICT

### 8.6.3.1 Applicability

All development, except detached accessory structures, in the Downtown Golden Triangle (D-GT) zone district shall comply with this Section's primary building form standards.

### 8.6.3.2 District Specific Standards Summary

The table below states the building forms allowed in each zone district. The table also summarizes the maximum number of structures allowed per Zone Lot, which is stated in more detail in Section 1.2.3.5, Number of Uses and Structures Allowed per Zone Lot.

See also Division 1.4, Building Form Standards - General Provisions, for additional standards related to initial assignment of building form standards to new and existing structures and for rules governing combining or changing building forms. Building Connectors between two detached structures shall follow the standards provided in Section 1.4.5, Applicable Building Form Standards for Detached Structures with Building Connector.

Downtown Golden Triangle Zone District	Building Forms	
	General	Point Tower
Max Number of Primary Structures Per Zone Lot	No Maximum	
Downtown Golden Triangle District (D-GT)	■	■

■ = Allowed

### 8.6.3.3 District Specific Standards

#### A. General

**Zone Lot Width 75 ft or Less**

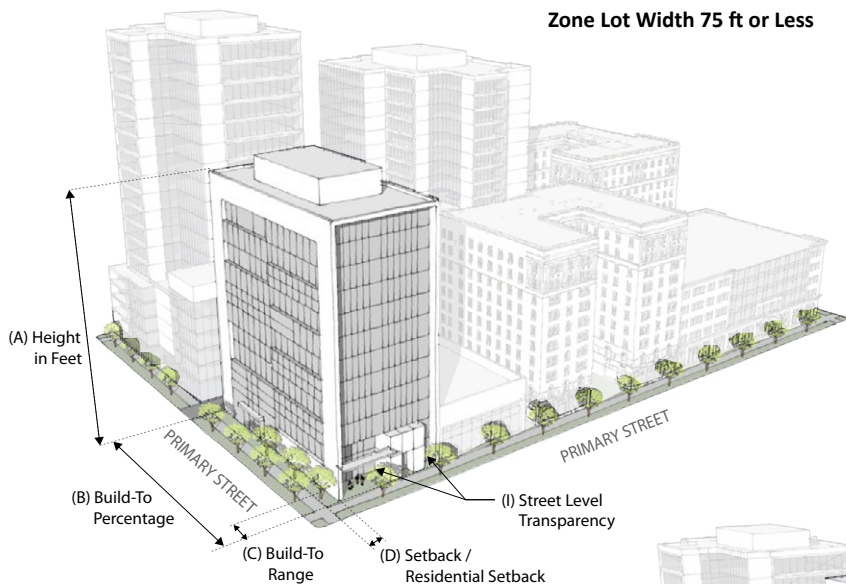

**Zone Lot Width more than 75 ft and up to 150 ft**

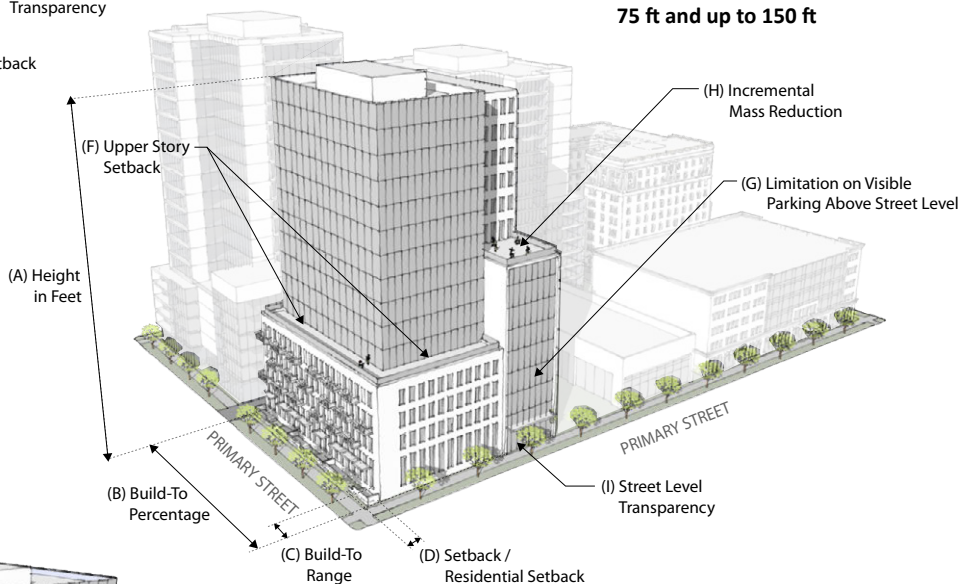

**Zone Lot Width more than 150 feet**

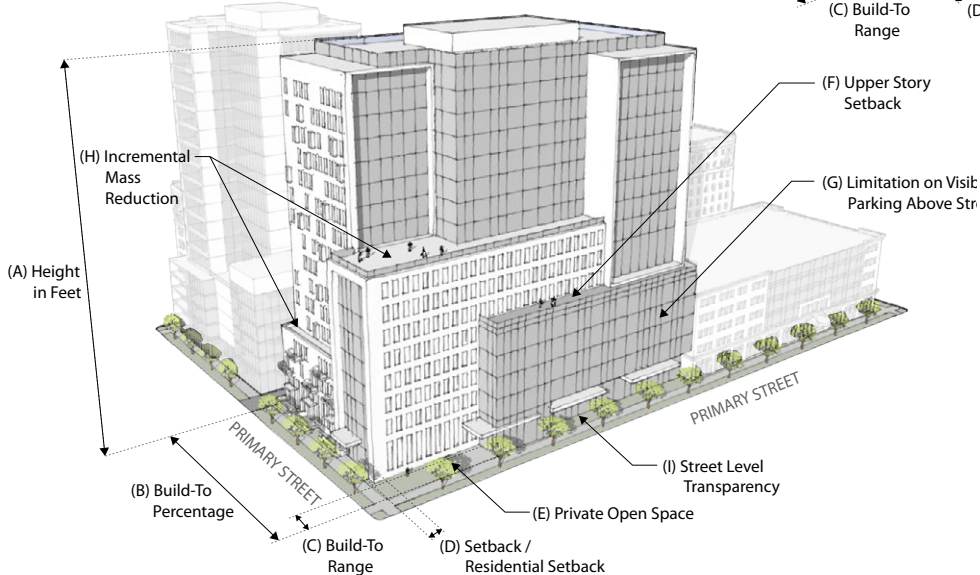

## GENERAL

		D-GT		
<b>HEIGHT AND FLOOR AREA</b>		Zone Lot width 75' or less	Zone Lot width more than 75' and up to 150'	Zone Lot width more than 150'
<b>FLOOR AREA RATIO (FAR)</b>				
FAR per Zone Lot/FAR with incentives per Zone Lot (max)		8.0 / 15.0 See Section 8.6.5.1	8.0 / 15.0 See Section 8.6.5.1	8.0 / 15.0 See Section 8.6.5.1
<b>HEIGHT</b>				
A	Zone Lot with FAR of 8.0 or less / Zone Lot with FAR more than 8.0 (max)	200' / 250'	200' / 250'	200' / 250'
<b>SITING</b>		Zone Lot width 75' or less	Zone Lot width more than 75' and up to 150'	Zone Lot width more than 150'
<b>REQUIRED BUILD-TO BY STREET</b>				
B	Primary Street (min build-to % )	70%	70%	70%
C	Primary Street (min/max build-to range) - Speer Blvd, Colfax Ave, 14th Ave.	10' / 20'	10' / 20'	10' / 20'
C	Primary Street (min/max build-to range) - All Others	0' / 10'	0' / 10'	0' / 10'
		Frontage Subject to a Residential Setback: 7' / 15'		
<b>SETBACKS</b>				
D	Primary Street (min) - Speer Blvd, Colfax Ave, 14th Ave	10'	10'	10'
D	Primary Street (min) - All Others	0'	0'	0'
Side Interior and Rear (min)		0'	0'	0'
<b>RESIDENTIAL SETBACKS</b>				
D	Primary Street (min) - Speer Blvd, Colfax Ave, 14th Ave	10'	10'	10'
D	Primary Street (min) - All Others	7'	7'	7'
<b>OPEN SPACE</b>				
E	Private Open Space (min)	na	na	5%
<b>PARKING</b>				
Surface Parking between Building and Primary Street		Not Allowed		
Surface Parking Screening Required		See Section 8.10.32		
Vehicle Access		Shall be determined as part of Site Development Plan Review		
<b>DESIGN ELEMENTS</b>		Zone Lot width 75' or less	Zone Lot width more than 75' and up to 150'	Zone Lot width more than 150'
<b>BUILDING CONFIGURATION</b>				
F	Upper Story Setback - Broadway, Lincoln St, Colfax Ave	No Upper Story Setback Required		
F	Upper Story Setback above 8 stories or 110' - Speer Blvd (min % of zone lot width/min setback)	100% / 20'	100% / 20'	100% / 20'
F	Upper Story Setback above 5 stories or 70' - All Others (min % of zone lot width/min setback)	na	Applies only to Structures more than 8 stories or 110': 65%/15'	65% / 15'
G	Limitation on Visible Parking Above Street Level for Structures over 5 stories or 70' in Height (min % of Primary Street-facing Zone Lot Width)	na	70% See Section 8.6.5.4	70% See Section 8.6.5.4
G	Limitation on Visible Parking Above Street Level Alternative	na	See Section 8.6.6.4	See Section 8.6.6.4
<b>INCREMENTAL MASS REDUCTION</b>				
H	Incremental Mass Reduction for Stories 3-8 (min)	na	0%	10%
H	Incremental Mass Reduction for Stories 9-16 (min)	na	15%	25%
H	Incremental Mass Reduction for Stories 17+ (min)	na	25%	35%
Incremental Mass Reduction Alternative		na	See Section 8.6.6.5	See Section 8.6.6.5
<b>STREET LEVEL ACTIVATION</b>				
I	Street Level Transparency, Primary Street (min for non-residential/min for residential-only buildings)	60% / 40%		
Pedestrian Access, Primary Street		Entrance		
Additional Pedestrian Access, Primary Street (min required for each Street Level Dwelling Unit)		Dwelling Unit Entrance with Entry Feature		
<b>USES</b>		Zone Lot width 75' or less	Zone Lot width more than 75' and up to 150'	Zone Lot width more than 150'
Permitted Primary Uses		All permitted Primary Uses shall be allowed within this building form		
Street Level Active Uses (min Primary Street % within Build-To min/max range and with Street Level Active Uses)		70% - See Section 8.6.5.2		
Street Level Nonresidential Active Uses on Specific Streets (min Primary Street % within Build-To min/max range and with Street Level Nonresidential Active Uses)		na	na	50% See Section 8.6.5.3

See Sections 8.6.5, 8.6.6, and 8.10.1 for Supplemental Design Standards, Design Standard Alternatives, and Design Standard Exceptions

## POINT TOWER

<b>HEIGHT AND FLOOR AREA</b>		D-GT
<b>FLOOR AREA RATIO (FAR)</b>		
FAR per Zone Lot/FAR with incentives per Zone Lot (max)		8.0 / 15.0 See Section 8.6.5.1
<b>HEIGHT</b>		
A	Zone Lot with FAR of 8.0 or less / Zone Lot with FAR more than 8.0 (max)	250' / 325'
<b>SITING</b>		D-GT
<b>ZONE LOT</b>		
Zone Lot Width (min)		150'
<b>REQUIRED BUILD-TO BY STREET</b>		
B	Primary Street (min build-to %)	70%
C	Primary Street (min/max build-to range) - Speer Blvd, Colfax Ave, 14th Ave	10'/20'
C	Primary Street (min/max build-to range) - All Others	0' / 10' Frontage Subject to a Residential Setback: 7' / 15'
<b>SETBACKS</b>		
D	Primary Street (min) - Speer Blvd, Colfax Ave, 14th Ave	10'
D	Primary Street (min) - All Others	0'
Side Interior and Rear (min)		0'
<b>RESIDENTIAL SETBACKS</b>		
D	Primary Street (min) - Speer Blvd, Colfax Ave, 14th Ave	10'
D	Primary Street (min) - All Others	7'
<b>OPEN SPACE</b>		
E	Private Open Space (min)	5%
<b>PARKING</b>		
Surface Parking between Building and Primary Street		Not allowed
Surface Parking Screening Required		See Section 8.10.32
Vehicle Access		Shall be determined as part of Site Development Plan Review
<b>DESIGN ELEMENTS</b>		D-GT
<b>BUILDING CONFIGURATION</b>		
F/G	Tower Floor Plate above 5 stories and 70' (max area / max linear dimension)	12,500 square feet / 180'
Tower Floor Plate Linear Dimension Alternative (max)		200' - See Section 8.6.6.3
H	Tower Floor Plate Separation above 5 stories or 70' (min)	120'
I	Upper Story Setback above 5 stories or 70' - Speer (min % of zone lot width/min setback)	100% / 20'
I	Upper Story Setback above 5 stories or 70' - All Others (min % of zone lot width/min setback)	100% / 15'
J	Limitation on Visible Parking Above Street Level for Structures over 5 stories or 70' in Height (min % of Primary Street-facing Zone Lot Width)	70% - See Section 8.6.5.4
Limitation on Visible Parking Above Street Level Alternative		See Section 8.6.6.4
<b>STREET LEVEL ACTIVATION</b>		
K	Street Level Transparency, Primary Street (min for non-residential/min for residential-only buildings)	60% / 40%
Pedestrian Access, Primary Street		Entrance
Additional Pedestrian Access, Primary Street (min required for each Street Level Dwelling Unit)		Dwelling Unit Entrance with Entry Feature
<b>USES</b>		D-GT
Permitted Primary Uses		All permitted Primary Uses shall be allowed within this building form
Street Level Active Uses (min Primary Street % within Build-To min/max range and with Street Level Active Uses)		70% - See Section 8.6.5.2
Street Level Nonresidential Active Uses on Specific Streets (min Primary Street % within Build-To min/max range and with Street Level Nonresidential Active Uses)		50% - See Section 8.6.5.3

See Sections 8.6.5, 8.6.6, and 8.10.1 for Supplemental Design Standards, Design Standard Alternatives, and Design Standard Exceptions

## DIVISION 8.7 DOWNTOWN ARAPAHOE SQUARE (D-AS) DISTRICT

### SECTION 8.7.1 ARAPAHOE SQUARE DISTRICT (D-AS)

#### 8.7.1.1 Generally

The provisions of this Division 8.7 apply to all lands, uses and structures in the Downtown Arapahoe Square (D-AS) zone district.

#### 8.7.1.2 Uses Permitted

See Division 8.11, Uses ~~and Minimum/Maximum Parking Requirements~~ for uses permitted in the D-AS District.

#### 8.7.1.3 Permitted Structures

##### A. Open Space Required

For each structure designed, used or occupied either in whole or in part as a multiple unit dwelling there shall be provided in the D-AS district a minimum of 30 square feet of unobstructed open space for each dwelling unit; such unobstructed open space may be located on the ground or on several usable roofs or balconies but shall not include space provided for off-street parking. Such requirement shall not apply to the construction of multiple unit dwellings through the conversion of buildings originally designed for nonresidential uses.

##### B. Setbacks from Abutting Street Frontages

Buildings shall be built at or within 10 feet of the zone lot line abutting the street for no less than 65% of each zone lot frontage, unless otherwise provided in this Division 8.7 or in Design Standards and Guidelines adopted for the D-AS District.

##### C. Maximum Height

In the D-AS district, the maximum height of structures shall not exceed 80 feet.

##### D. Maximum Gross Floor Area in Structures

###### 1. Maximum Floor Area Ratio

The total floor area ratio of all existing and proposed Structures on a Zone Lot shall not exceed 4.0 FAR without meeting the requirements of this Section 8.7.1.3.D.

###### 2. Floor Area Premiums

In addition to the maximum floor area ratio permitted under Section 8.7.1.3.D.1 above, additional floor area may be constructed using one or more of the following floor area premiums, or transfers of undeveloped floor area.

###### a. Allowance

Floor area premiums and transfers of undeveloped floor area shall not:

- i. Increase the floor area ratio on any Zone Lot by more than the maximum amount shown in the following table; or
- ii. Cause the total floor area ratio allowed on any Zone Lot to exceed the maximum floor area ratio with premiums and transfers stated in Section 8.7.1.3.D.3 below.

	ZONE DISTRICTS	BUILDING FORMS	PRIMARY STREET
Wall-mounted fixtures, wiring, conduit, piping, and vents integral to conventional mechanical, electrical, plumbing, and fire protection systems (1) not otherwise identified as an allowed setback encroachment; and (2) serving permitted uses on the zone lot; and (3) projecting no more than 18-inches from the exterior face of the exterior wall  Including but not limited to electrical panelboards, controllers, sensors, meters, drains, hosebibs, hydrants, fire department connections, sprinklers, alarms, dryer vents, bathroom vents, furnace vents, radon exhaust fans, lighting fixtures, and similar minor utility features approved by the Zoning Administrator	All D-GT and D-CPV-T/R/C Zone Districts	All building forms	Any distance

## REFERENCE TO OTHER APPLICABLE DESIGN STANDARDS

See Article 10, General Design Standards.

## SECTION 8.10.2 SURFACE PARKING LOT LANDSCAPING

### A. Applicability

- Surface Parking as a primary use in the D-C, D-TD, D-LD, D-GT, D-AS and D-CV zones shall be landscaped according to this Section 8.10.32.

### B. Street Tree Planting Required

- Street trees shall be required on all street frontages for all proposed new parking areas.
- Such trees shall be located on the public right-of-way where the available space between the flow line (face of curb) and the right-of-way/private property line is at least 10 feet wide and where no unusual problem or physical constraint exists. If such problem or constraint does occur in this situation, then the trees shall be located on private property.

### C. Screening Device Required

- In addition to required street tree planting, a decorative screening device is required that conforms to city design concepts or a similar screening device as may be acceptable to the Zoning Administrator. The height of such device may vary between 2 feet and 4 feet. Such screening device shall be located on private property.
- Except for required street tree planting and additional standards in Section 8.10.32.D, no tree lawn, landscaping or interior landscaping is required; however, owners may submit for Zoning Administrator review proposals for alternative designs that incorporate landscaping (sod and/or shrubs) with the screening device.



Illustration 1: D-C, D-TD, D-LD, D-CV, D-AS and D-GT Zone Districts

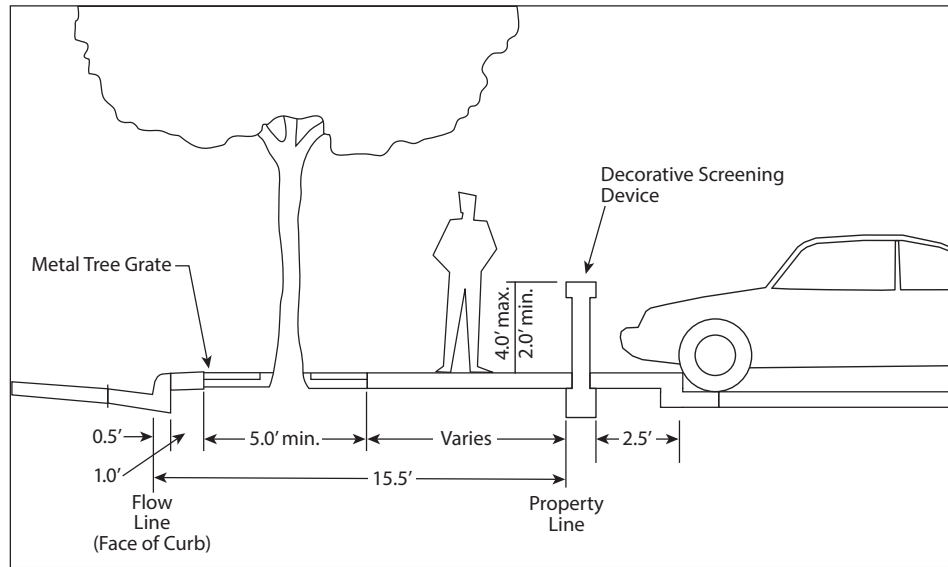

## D. Additional D-GT and D-AS Zone District Parking Lot Landscaping Requirements

### 1. Tree Lawn Required

- a. In addition to required street tree planting, a street front tree-lawn at least 8 feet wide shall be required between the flow line and the parking lot. If the space between the flow line and the property line is inadequate to install an 8-foot wide tree lawn, the width of such tree lawn may be reduced; however, in no case shall it be reduced to less than 5 feet in width. Further, if such 5-foot wide tree lawn is located partially on private property, that portion on private property shall be counted toward the satisfaction of the 5% area requirement of Section D.2 below.
- b. “Tree lawn” for the purposes of this provision is defined as a linear strip of ground which contains trees as required by Section 8.10.32.B above.
- c. A tree lawn is generally located on the public right-of-way, but may in some cases be partially located on private property.

### 2. Additional Parking Lot Landscaping Requirement

An area of landscaping equal to 5% of the parking area shall be provided in addition to street tree and tree lawn landscaping areas. This additional landscaped area may be located:

- a. In the interior of the parking area according to the standards in Section 10.5.4.5, Interior Surface Parking Lot Landscaping Standards; or
- b. Along the street front as an addition to the tree lawn in the case of attached sidewalks; or
- c. With detached sidewalks, this area may be in the form of a landscaped planting strip with a minimum width of 5 feet located between the sidewalk and the parking area.

### 3. Pedestrian Access

A 3-foot-wide opening for pedestrians shall be located a maximum of 80 feet apart along all public street and alley frontages of the parking lot.

### 4. Variations Allowed

Variations in the arrangement or location of the tree lawn may be allowed depending on the location of existing sidewalks or on the quality of design proposals made by the developer according to the minimum widths set forth in Section 8.10.32.D.1 above.

## **DIVISION 8.11 USES ~~AND MINIMUM/MAXIMUM PARKING~~ REQUIREMENTS**

### **SECTION 8.11.1 APPLICABILITY**

- 8.11.1.1 This Division 8.11 sets forth the land uses permitted; ~~and the~~ required zoning procedures; ~~and the minimum/maximum parking requirements~~ in all the Downtown Neighborhood Context zone districts ~~with the exception of the D-LD zone district (see Section 8.4.1.4).~~
- 8.11.1.2 ~~See Section 8.3.1.5 for more information on vehicle and bicycle parking in the D-C, D-TD and D-CV zone districts:~~
- 8.11.1.3 ~~Maximum parking requirements apply only in the D-CPV-T, D-CPV-R and D-CPV-C zone districts as set forth in Section 8.11.5.~~ Maximum parking requirements moved to new section 10.4.4.4
- 8.11.1.4 ~~Note that the D-C, D-TD, D-CV, D-GT, D-AS-12+, D-AS-20+, D-CPV-T, D-CPV-R and D-CPV-C All Downtown Neighborhood Context zone districts have no minimum off-street vehicle parking requirement:~~
- 8.11.1.5 Uses not listed are prohibited, unless the Zoning Administrator specifically permits the unlisted use according to Section 12.4.6, Code Interpretations and Determination of Unlisted Uses.
- 8.11.1.6 For number of primary and accessory uses allowed per Zone Lot, see Section 1.2.3.5, Number of Uses and Structures Allowed per Zone Lot.

### **SECTION 8.11.2 ORGANIZATION OF USE ~~& MINIMUM PARKING~~ TABLE**

#### **8.11.2.1 Organized by Primary, Accessory and Temporary Uses**

The Use ~~and Minimum Parking~~ Table first presents all primary uses, then all accessory uses, and finally all temporary uses. Primary uses are arranged hierarchically within the table by use classification, category of primary uses, and then by specific use type. Accessory uses are organized by whether such use is accessory to a primary residential use or to a primary nonresidential use. Temporary uses are presented alphabetically ordered in the last division of the table.

#### **8.11.2.2 Primary Use Classifications, Categories & Specific Use Types**

##### **A. Primary Use Classifications**

All primary land uses in the Use ~~and Minimum Parking~~ Table are organized into one of the following five general land use classifications:

1. Residential Uses
2. Civic, Public & Institutional Uses
3. Commercial Sales, Service & Repair Uses
4. Industrial, Manufacturing & Wholesale Uses
5. Agriculture

##### **B. Primary Use Categories & Specific Use Types**

Primary uses are further organized into use categories and specific use types listed under each general primary land use classification. The Use ~~and Minimum Parking~~ Table is organized into the above five general land use classifications, use categories and specific use types.

##### **C. Classifications & Categories Are Mutually Exclusive**

The general land use classifications and use categories listed in the Use ~~and Minimum Parking~~ Table are intended to be mutually exclusive; that is, a use classified into one use category, such

as “lodging accommodations,” cannot be classified in a different use category, such as “congregate living,” unless otherwise expressly allowed by this Code.

## SECTION 8.11.3 EXPLANATION OF USE ~~& MINIMUM PARKING~~ TABLE ABBREVIATIONS

### 8.11.3.1 General Explanation of Table Cell Entries

In each of the table cells, the entry will indicate first whether use limitations apply to the specific use, and then separated by a hyphen, the type of zoning review required prior to establishment of the use under this Code. For example, as described in more detail below, a cell entry “L-ZPIN” means, first, the use is subject to use limitations (the “L”), and, second, that the use is subject to zoning permit review with information notice (the “ZPIN”) prior to its establishment.

### 8.11.3.2 Permitted, Limited, Not Permitted

#### A. Permitted Use - No Use Limitations Apply (“P”)

A “P” in a table cell indicates that the use is permitted in the respective zone district, and is not subject to use limitations.

#### B. Permitted Use - Subject to Use Limitations (“L”)

“L” in a table cell indicates the use is permitted in the zone district subject to compliance with the use limitations referenced in the last column of the use table (“Applicable Use Limitations”).

#### C. Uses Not Permitted (“NP”)

“NP” in a table cell indicates that the use is not permitted in the specific zone district.

### 8.11.3.3 Zoning Procedure

#### A. Use Subject to Zoning Permit Review (“ZP”)

“ZP” in a table cell indicates that the use is permitted in the respective zone district only if reviewed and approved according to the requirements in Section 12.4.1, Zoning Permit Review.

#### B. Use Subject to Zoning Permit Review with Informational Notice (“ZPIN”)

“ZPIN” in a table cell indicates that the use is permitted in the respective zone district only if reviewed and approved according to the public notice and procedural requirements in Section 12.4.2, Zoning Permit Review with Informational Notice. Such uses shall comply with any applicable use limitations noted in the last column of the use table (“Applicable Use Limitations”), as well as the review criteria stated in Section 12.4.2, Zoning Permit Review with Informational Notice.

#### C. Use Subject to Zoning Permit Review with Community Information Meeting (“ZPCIM”)

“ZPCIM” in a table cell indicates that the use is permitted in the respective zone district only if reviewed and approved according to the public notice and procedural requirements in Section 12.4.1, Zoning Permit Review. Prior to formal application, an applicant shall schedule a community information meeting and provide public notice of the community information meeting according to Section 12.3.4.6, Community Information Meeting.

**D. Use Subject to Zoning Permit with Special Exception Review (“ZPSE”)**

“ZPSE” in a table cell indicates that use is generally appropriate in the neighborhood context and zone district, yet may have the potential for limited impacts on adjacent properties or on the established character of the neighborhood context or zone district. “ZPSE” uses are subject to a Board of Adjustments public hearing according to Section 12.4.9, Zoning Permit with Special Exception Review, which grants the Board of Adjustment the authority to impose conditions on the specified use to mitigate any potential impacts. Such uses shall comply with any applicable use limitations noted in the last column of the use table (“Applicable Use Limitations”), as well as the review criteria stated in Section 12.4.9, Zoning Permit with Special Exception Review.

**E. Uses Where More Than One Zoning Procedure Is Indicated**

Where a table cell shows more than one zoning procedure applies to a use, for example “L-ZP/ZPIN”, the referenced use limitation (last table column) will indicate which zoning procedure applies in a specific case. For example, a table cell may indicate “L-ZPIN/ZPSE” for a use. This means that the ZPIN zoning procedure will apply, unless the applicable use limitation specifies the ZPSE zoning procedure is triggered (e.g., by proximity to a Protected District).

**8.11.3.4 Enclosure of Uses**

All primary, accessory and temporary uses must be established, operated and maintained within a Completely Enclosed Structure, unless otherwise specifically allowed by this Code. The Use and Parking Tables in Articles 3-9 indicate when a use may be established, operated or maintained outside a Completely Enclosed Structure by including an asterisk “\*” next to the specific use type. For example, the asterisk following the “Telecommunication Tower\*” use type in the tables indicates that a telecommunication tower land use need not be enclosed.

**SECTION 8.11.4 DISTRICT SPECIFIC STANDARDS (USE & MINIMUM PARKING TABLE)**

KEY: \* = Need Not be Enclosed P = Permitted Use without Limitations L = Permitted Use with Limitations NP = Not Permitted Use ZP = Zoning Permit Review  
ZPCIM = Subject to Zoning Permit Review with Community Information Meeting ZPIN = Subject to Zoning Permit Review with Informational Notice  
ZPSE = Subject to Zoning Permit with Special Exception Review When no ZP, ZPCIM, ZPIN, ZPSE listed = No Zoning Permit required

USE CATEGORY	SPECIFIC USE TYPE <del>D-C, D-TD, D-CV, D-GT, D-AS-12+/20+, D-LD, D-CPV-T/R/C Districts have no minimum vehicle parking requirement. D-CPV-T/R/C maximum vehicle parking requirements are provided in Section 8.11.5. D-C, D-TD, D-CV bicycle parking requirements are provided in Section 8.3.1.5:</del> <ul style="list-style-type: none"> <li>• Vehicle Parking Reqmt: # spaces per unit of measurement</li> <li>• Bicycle Parking Reqmt Requirement: # spaces per unit of measurement (% Required Spaces in Enclosed Facility /% Required Spaces in Fixed Facility)</li> </ul>						D-AS-12+ D-AS-20+ D-CPV-T D-CPV-R D-CPV-C		APPLICABLE USE LIMITATIONS
		D-C	D-TD	D-LD	D-CV	D-GT D-AS			
<b>RESIDENTIAL PRIMARY USE CLASSIFICATION</b>									
Household Living	Dwelling, Single Unit • Bicycle: No Parking Requirements	L-ZP	L-ZP	L-ZP	NP	L-ZP	L-ZP		\$11.2.7
	Dwelling, Two Unit • D-AS Districts – Vehicle: 0.75/unit • Bicycle: No requirement	L-ZP	L-ZP	L-ZP	NP	L-ZP	L-ZP		\$11.2.2; \$11.2.7
	Dwelling, Multi-Unit • D-AS Districts – Vehicle: 0.75/unit • D-GT, D-AS, & D-AS-12+/20+ Districts – Bicycle: 1/2 units (80/20) • D-CPV-T/R/C & D-LD Districts – Bicycle: 1.1/unit (80/20)	L-ZP	L-ZP	L-ZP	NP	L-ZP	L-ZP		\$11.2.3; \$11.2.7
	Dwelling, Live / Work • D-AS Districts – Vehicle: 0.75/unit • D-GT, D-AS, & D-AS-12+/20+ Districts – Bicycle: 1/2 units (80/20) • D-CPV-T/R/C Districts – Bicycle: 1.1/unit (80/20)	L-ZP	L-ZP	L-ZP	NP	L-ZP	L-ZP		\$11.2.4; \$11.2.7

**Modernizing Parking Requirements**  
**LUTI Committee Review Draft**  
 May 13, 2025

Article 8. Downtown Neighborhood Context  
 Division 8.11 Uses and Minimum/Maximum Parking Requirements

KEY: \* = Need Not be Enclosed P = Permitted Use without Limitations L = Permitted Use with Limitations NP = Not Permitted Use ZP = Zoning Permit Review  
 ZPCIM = Subject to Zoning Permit Review with Community Information Meeting ZPIN = Subject to Zoning Permit Review with Informational Notice  
 ZPSE = Subject to Zoning Permit with Special Exception Review When no ZP, ZPCIM, ZPIN, ZPSE listed = No Zoning Permit required

USE CATEGORY	SPECIFIC USE TYPE <del>D-C, D-TD, D-CV, D-GT, D-A5-12+/20+, D-LD, D-CPV-T/R/C Districts have no minimum vehicle parking requirement. D-CPV-T/R/C maximum vehicle parking requirements are provided in Section 8.11.5. D-C, D-TD, D-CV bicycle parking requirements are provided in Section 8.3.1.5.</del> • <del>Vehicle Parking Reqmt: # spaces per unit of measurement</del> • <del>Bicycle Parking Reqmt Requirement: # spaces per unit of measurement (% Required Spaces in Enclosed Facility / % Required Spaces in Fixed Facility)</del>							APPLICABLE USE LIMITATIONS
		D-C	D-TD	D-LD	D-CV	D-GT D-AS	D-AS-12+ D-AS-20+ D-CPV-T D-CPV-R D-CPV-C	
	Manufactured Home Community	NP	NP	NP	NP	NP	NP	
Residential Care	Residential Care, Type 1 • <del>D-AS Districts - Vehicle: No requirement</del> • <del>Bicycle: 1/8,000 sf GFA (80/20)</del>	L/L-ZP	L/L-ZP	L/L-ZP	L/L-ZP	L/L-ZP	L/L-ZP	§11.2.8; §11.2.9
	Residential Care, Type 2 • <del>D-AS Districts - Vehicle: No requirement</del> • <del>Bicycle: 1/8,000 sf GFA (80/20)</del>	L-ZP	L-ZP	L-ZP	L-ZP	L-ZP	L-ZP	§11.2.8; §11.2.10
	Residential Care, Type 3 • <del>D-AS Districts - Vehicle: No Requirement</del> • <del>Bicycle: 1/8,000 sf GFA (80/20)</del>	L-ZPCIM	L-ZPCIM	L-ZPCIM	L-ZPCIM	L-ZPCIM	L-ZPCIM	§11.2.8; §11.2.11
	Residential Care, Type 4 • <del>D-AS Districts - Vehicle: No Requirement</del> • <del>Bicycle: 1/8,000 sf GFA (80/20)</del>	L-ZPCIM	L-ZPCIM	L-ZPCIM	L-ZPCIM	L-ZPCIM	L-ZPCIM	§11.2.8; §11.2.12
Congregate Living	All Types • <del>D-AS Districts - Vehicle: .25/1,000 sf GFA</del> • <del>Bicycle: 1/8,000 sf GFA (80/20)</del>	P-ZP	P-ZP	P-ZP	P-ZP	P-ZP	P-ZP	
<b>CIVIC, PUBLIC &amp; INSTITUTIONAL PRIMARY USE CLASSIFICATION</b>								
Basic Utilities	Utility, Major Impact* • <del>D-AS Districts - Vehicle: .5/1,000 s.f. GFA</del> • <del>D-GT, D-AS, D-AS-12+/20+ &amp; D-CPV-T/R/C Districts - Bicycle: No requirement</del>	L-ZPSE	L-ZPSE	L-ZPSE	L-ZPSE	L-ZPSE	L-ZPSE	§ 11.3.1
	Utility, Minor Impact* • <del>D-AS Districts - Vehicle: .5/1,000 s.f. GFA</del> • <del>D-GT, D-AS, D-AS-12+/20+ &amp; D-CPV-T/R/C Districts - Bicycle: No requirement</del>	L-ZP	L-ZP	L-ZP	L-ZP	L-ZP	L-ZP	§ 11.3.2

KEY: \* = Need Not be Enclosed P = Permitted Use without Limitations L = Permitted Use with Limitations NP = Not Permitted Use ZP = Zoning Permit Review  
 ZPCIM = Subject to Zoning Permit Review with Community Information Meeting ZPIN = Subject to Zoning Permit Review with Informational Notice  
 ZPSE = Subject to Zoning Permit with Special Exception Review When no ZP, ZPCIM, ZPIN, ZPSE listed = No Zoning Permit required

USE CATEGORY	SPECIFIC USE TYPE <del>D-C, D-TD, D-CV, D-GT, D-AS-12+/20+, D-LD, D-CPV-T/R/C Districts have no minimum vehicle parking requirement. D-CPV-T/R/C maximum vehicle parking requirements are provided in Section 8.11.5. D-C, D-TD, D-CV bicycle parking requirements are provided in Section 8.3.1.5.</del> • <del>Vehicle Parking Reqmt: # spaces per unit of measurement</del> • <del>Bicycle Parking Reqmt Requirement: # spaces per unit of measurement (% Required Spaces in Enclosed Facility / % Required Spaces in Fixed Facility)</del>							APPLICABLE USE LIMITATIONS
		D-C	D-TD	D-LD	D-CV	D-GT D-AS	D-AS-12+ D-AS-20+ D-CPV-T D-CPV-R D-CPV-C	
Community/ Public Services	Community Center* • <del>Bicycle: No Parking Requirements</del>	L-ZP	L-ZP	L-ZP	L-ZP	L-ZP	L-ZP	§ 11.3.3
	Day Care Center • <del>D-AS Districts - Vehicle: 1/1,000 s.f. GFA</del> • <del>D-GT, D-AS, &amp; D-AS-12+/20+ Districts - Bicycle: 1/10,000 s.f. GFA (0/100)</del> • <del>D-CPV-T/R/C Districts - Bicycle: 1/5,000 s.f. GFA (0/100)</del>	P-ZP	P-ZP	P-ZP	P-ZP	P-ZP	P-ZP	
	Postal Facility, Neighborhood • <del>D-AS Districts - Vehicle: 1.25/1,000 s.f. GFA</del> • <del>D-GT, D-AS, &amp; D-AS-12+/20+ Districts - Bicycle: 1/7,500 s.f. GFA (20/80)</del> • <del>D-CPV-T/R/C Districts - Bicycle: 1/4,000 s.f. GFA (20/80)</del>	P-ZP	P-ZP	P-ZP	P-ZP	P-ZP	P-ZP	
	Postal Processing Center • <del>D-AS Districts - Vehicle: 1/1,000 s.f. GFA</del> • <del>D-GT, D-AS, &amp; D-AS-12+/20+ Districts - Bicycle: 1/7,500 s.f. GFA (20/80)</del> • <del>D-CPV-T/R/C Districts - Bicycle: 1/4,000 s.f. GFA (20/80)</del>	P-ZP	P-ZP	P-ZP	NP	P-ZP	P-ZP	
	Public Safety Facility • <del>D-AS Districts - Vehicle: 1/1,000 s.f. GFA</del> • <del>D-GT, D-AS, &amp; D-AS-12+/20+ Districts - Bicycle: 1/10,000 s.f. GFA (0/100)</del> • <del>D-CPV-T/R/C Districts - Bicycle: 1/5,000 s.f. GFA (0/100)</del>	P-ZP	P-ZP	P-ZP	P-ZP	P-ZP	P-ZP	
	Hospital	P-ZP	P-ZP	NP	NP	NP	D-AS-12+/20+ & D-CPV-T/R: NP D-CPV-C: P-ZP	
	Correctional Institution	NP	NP	NP	NP	NP	NP	
Cultural/Special Purpose/Public Parks & Open Space	Cemetery*	NP	NP	NP	NP	NP	NP	
	Library • <del>D-AS Districts - Vehicle: 1/1,000 s.f. GFA</del> • <del>D-GT, D-AS, &amp; D-AS-12+/20+ Districts - Bicycle: 1/10,000 s.f. GFA (0/100)</del> • <del>D-CPV-T/R/C Districts - Bicycle: 1/5,000 s.f. GFA (0/100)</del>	P-ZP	P-ZP	P-ZP	P-ZP	P-ZP	P-ZP	
	Museum • <del>D-AS Districts - Vehicle: 1/1,000 s.f. GFA</del> • <del>D-GT, D-AS, &amp; D-AS-12+/20+ Districts - Bicycle: 1/10,000 s.f. GFA (0/100)</del> • <del>D-CPV-T/R/C Districts - Bicycle: 1/5,000 s.f. GFA (0/100)</del>	P-ZP	P-ZP	P-ZP	P-ZP	P-ZP	P-ZP	
	City Park*	NP	NP	NP	NP	NP	NP	
	Open Space - Conservation* • <del>Bicycle: No Parking Requirements</del>	P-ZP	P-ZP	P-ZP	P-ZP	P-ZP	P-ZP	

**Modernizing Parking Requirements**  
**LUTI Committee Review Draft**  
 May 13, 2025

Article 8. Downtown Neighborhood Context  
 Division 8.11 Uses and Minimum/Maximum Parking Requirements

KEY: \* = Need Not be Enclosed P = Permitted Use without Limitations L = Permitted Use with Limitations NP = Not Permitted Use ZP = Zoning Permit Review  
 ZPCIM = Subject to Zoning Permit Review with Community Information Meeting ZPIN = Subject to Zoning Permit Review with Informational Notice  
 ZPSE = Subject to Zoning Permit with Special Exception Review When no ZP, ZPCIM, ZPIN, ZPSE listed = No Zoning Permit required

USE CATEGORY	SPECIFIC USE TYPE <del>D-C, D-TD, D-CV, D-GT, D-AS-12+/20+, D-LD, D-CPV-T/R/C Districts have no minimum vehicle parking requirement. D-CPV-T/R/C maximum vehicle parking requirements are provided in Section 8.11.5. D-C, D-TD, D-CV bicycle parking requirements are provided in Section 8.3.1.5.</del> • <del>Vehicle Parking Reqmt: # spaces per unit of measurement</del> • <del>Bicycle Parking Reqmt Requirement: # spaces per unit of measurement (% Required Spaces in Enclosed Facility / % Required Spaces in Fixed Facility)</del>							APPLICABLE USE LIMITATIONS D-AS-12+ D-AS-20+ D-CPV-T D-CPV-R D-CPV-C
		D-C	D-TD	D-LD	D-CV	D-GT D-AS		
Education	Elementary or Secondary School <del>• D-AS Districts - Vehicle - Elementary: 1/1,000 s.f. GFA</del> <del>• D-GT, D-AS, &amp; D-AS-12+/20+ Districts - Bicycle - Elementary: 1/10,000 s.f. GFA (0/100)</del> <del>• D-CPV-T/R/C Districts - Bicycle - Elementary: 1/5,000 s.f. GFA (0/100)</del> <del>• D-AS Districts - Vehicle - Secondary: 1/1,000 s.f. GFA</del> <del>• D-GT, D-AS, D-AS-12+/20+ &amp; D-CPV-T/R/C Districts - Bicycle - Secondary: 1/5,000 s.f. GFA (0/100)</del>	L-ZP	L-ZP	L-ZP	L-ZP	L-ZP	L-ZP	§ 11.3.8
	University or College <del>• D-AS Districts - Vehicle: 1/1,000 s.f. GFA</del> <del>• D-GT, D-AS, &amp; D-AS-12+/20+ Districts - Bicycle: 1/10,000 s.f. GFA (0/100)</del> <del>• D-CPV-T/R/C Districts - Bicycle: 1/5,000 s.f. GFA (0/100)</del>	L-ZP	L-ZP	L-ZP	L-ZP	L-ZP	L-ZP	§ 11.3.8; § 11.3.9
	Vocational or Professional School <del>• D-AS Districts - Vehicle: 1/1,000 s.f. GFA</del> <del>• D-GT, D-AS, &amp; D-AS-12+/20+ Districts - Bicycle: 1/10,000 s.f. GFA (0/100)</del> <del>• D-CPV-T/R/C Districts - Bicycle: 1/5,000 s.f. GFA (0/100)</del>	L-ZP	L-ZP	L-ZP	L-ZP	L-ZP	L-ZP	§ 11.3.8
Public and Religious Assembly	All Types • <del>Bicycle: No Parking Requirements</del>	P-ZP	P-ZP	P-ZP	P-ZP	P-ZP	P-ZP	
<b>COMMERCIAL SALES, SERVICES, &amp; REPAIR PRIMARY USE CLASSIFICATION</b>								
Adult Business	All Types	NP	NP	NP	NP	NP	NP	See Section 9.4.4, Use Overlay Districts, for adult business use allowance in the UO-1 District.
Arts, Recreation & Entertainment	Arts, Recreation and Entertainment Services, Indoor <del>• D-AS Districts - Vehicle - Artist Studio: 0.3/1000 sf GFA</del> <del>• D-AS Districts - Vehicle - All Others: 1.25/1,000 s.f. GFA</del> <del>• D-GT, D-AS, &amp; D-AS-12+/20+ Districts - Bicycle: 1/7,500 s.f. GFA (20/80)</del> <del>• D-CPV-T/R/C Districts - Bicycle: 1/4,000 s.f. GFA (20/80)</del>	P-ZP	P-ZP	P-ZP	P-ZP	P-ZP	P-ZP	
	Arts, Recreation and Entertainment Services, Outdoor* <del>• D-AS Districts - Vehicle: 1.25/1,000 s.f. GFA</del> <del>• D-GT, D-AS, &amp; D-AS-12+/20+ Districts - Bicycle: 1/7,500 s.f. GFA (20/80)</del> <del>• D-CPV-T/R/C Districts - Bicycle: 1/4,000 s.f. GFA (20/80)</del>	L-ZP	L-ZP	L-ZPIN	L-ZPIN	L-ZPIN	L-ZPIN	§ 11.4.3
	Event Space with Alternate Parking and Loading* • <del>Vehicle: No requirement</del> • <del>Bicycle: No requirement</del>	NP	NP	NP	NP	NP	NP	
	Sports and/or Entertainment Arena or Stadium*	NP	NP	NP	NP	NP	D-AS-12+/20+ & D-CPV-T/R: NP D-CPV-C: P-ZP	

KEY: \* = Need Not be Enclosed P = Permitted Use without Limitations L = Permitted Use with Limitations NP = Not Permitted Use ZP = Zoning Permit Review  
 ZPCIM = Subject to Zoning Permit Review with Community Information Meeting ZPIN = Subject to Zoning Permit Review with Informational Notice  
 ZPSE = Subject to Zoning Permit with Special Exception Review When no ZP, ZPCIM, ZPIN, ZPSE listed = No Zoning Permit required

USE CATEGORY	SPECIFIC USE TYPE <del>D-C, D-TD, D-CV, D-GT, D-AS-12+/20+, D-LD, D-CPV-T/R/C Districts have no minimum vehicle parking requirement. D-CPV-T/R/C maximum vehicle parking requirements are provided in Section 8.11.5. D-C, D-TD, D-CV bicycle parking requirements are provided in Section 8.3.1.5.</del> • <del>Vehicle Parking Reqmt: # spaces per unit of measurement</del> • <del>Bicycle Parking Reqmt Requirement: # spaces per unit of measurement (% Required Spaces in Enclosed Facility / % Required Spaces in Fixed Facility)</del>							APPLICABLE USE LIMITATIONS D-AS-12+ D-AS-20+ D-CPV-T D-CPV-R D-CPV-C
		D-C	D-TD	D-LD	D-CV	D-GT D-AS		
Nonresidential Uses in Existing Business Structures In Residential Zones		Not Applicable						
Parking of Vehicles	Parking, Garage • <del>Bicycle: No Parking Requirements</del>	L-ZP	L-ZP	NP	NP	L-ZP/ZPIN	P-ZP	§ 11.4.7
	Parking, Surface* • <del>Bicycle: No Parking Requirements</del>	L-ZP	L-ZP	NP	NP	D-GT: L-ZPIN D-AS: P-ZPIN	NP	§ 11.4.8
Eating & Drinking Establishments	All Types • <del>D-AS Districts - Vehicle: 2.5/1,000 s.f. GFA</del> • <del>D-GT, D-AS, D-AS-12+/20+ &amp; D-CPV-T/R/C Districts - Bicycle: 1/1,000 s.f. GFA (0/100)</del>	P-ZP	P-ZP	P-ZP	P-ZP	P-ZP	P-ZP	
Lodging Accommodations	Bed and Breakfast Lodging • <del>D-AS Districts - Vehicle - MS only: 2/1,000 s.f. GFA</del> • <del>D-AS Districts - Vehicle: 0.875/guest room or unit</del> • <del>D-GT, D-AS, D-AS-12+/20+, &amp; D-CPV-T/R/C Districts - Bicycle: 1/7,500 s.f. GFA (20/80)</del>	P-ZP	P-ZP	P-ZP	NP	P-ZPIN	P-ZP	
	Lodging Accommodations, All Others • <del>D-AS Districts - Vehicle: 0.875/guest room or unit</del> • <del>D-GT, D-AS, D-AS-12+/20+, &amp; D-CPV-T/R/C Districts - Bicycle: 1/7,500 s.f. GFA (20/80)</del>	P-ZP	P-ZP	P-ZP	NP	P-ZPIN	P-ZP	
Office	Dental / Medical Office or Clinic • <del>D-AS Districts - Vehicle: 1.25/1,000 s.f. GFA</del> • <del>D-GT, D-AS, &amp; D-AS-12+/20+ Districts - Bicycle: 1/7,500 s.f. GFA (20/80)</del> • <del>D-CPV-T/R/C Districts - Bicycle: 1/4,000 s.f. GFA (20/80)</del>	L-ZP	L-ZP	L-ZP	NP	L-ZP	L-ZP	§ 11.4.10
	Office, All Others • <del>D-AS Districts - Vehicle: 1.25/1,000 s.f. GFA</del> • <del>D-GT, D-AS, &amp; D-AS-12+/20+ Districts - Bicycle: 1/7,500 s.f. GFA (20/80)</del> • <del>D-CPV-T/R/C Districts - Bicycle: 1/4,000 s.f. GFA (20/80)</del>	P-ZP	P-ZP	P-ZP	P-ZP	P-ZP	P-ZP	
Retail Sales, Service & Repair (Not Including Vehicle or Equipment Sales, Service & Repair)	Animal Sales and Services, Household Pets Only • <del>D-AS Districts - Vehicle: 1.25/1,000 s.f. GFA</del> • <del>D-GT, D-AS, &amp; D-AS-12+/20+ Districts - Bicycle: 1/7,500 s.f. GFA (20/80)</del> • <del>D-CPV-T/R/C Districts - Bicycle: 1/4,000 s.f. GFA (20/80)</del>	L-ZP	L-ZP	L-ZP	NP	L-ZP	L-ZP	§ 11.4.12
	Animal Sales and Services, All Others • <del>Bicycle: No Parking Requirements</del>	P-ZP	P-ZP	NP	NP	NP	NP	
	Food Sales or Market • <del>D-AS Districts - Vehicle: 1.25/1,000 s.f. GFA</del> • <del>D-GT, D-AS, &amp; D-AS-12+/20+ Districts - Bicycle: 1/7,500 s.f. GFA (20/80)</del> • <del>D-CPV-T/R/C Districts - Bicycle: 1/4,000 s.f. GFA (20/80)</del>	P-ZP	P-ZP	P-ZP	P-ZP	P-ZP	P-ZP	



**Modernizing Parking Requirements**  
**LUTI Committee Review Draft**  
**May 13, 2025**

Article 8. Downtown Neighborhood Context  
 Division 8.11 Uses and Minimum/Maximum Parking Requirements

KEY: \* = Need Not be Enclosed P = Permitted Use without Limitations L = Permitted Use with Limitations NP = Not Permitted Use ZP = Zoning Permit Review  
 ZPCIM = Subject to Zoning Permit Review with Community Information Meeting ZPIN = Subject to Zoning Permit Review with Informational Notice  
 ZPSE = Subject to Zoning Permit with Special Exception Review When no ZP, ZPCIM, ZPIN, ZPSE listed = No Zoning Permit required

USE CATEGORY	SPECIFIC USE TYPE <del>D-C, D-TD, D-CV, D-GT, D-AS-12+/20+, D-LD, D-CPV-T/R/C Districts have no minimum vehicle parking requirement. D-CPV-T/R/C maximum vehicle parking requirements are provided in Section 8.11.5. D-C, D-TD, D-CV bicycle parking requirements are provided in Section 8.3.1.5.</del> • <del>Vehicle Parking Reqmt: # spaces per unit of measurement</del> • <del>Bicycle Parking Reqmt Requirement: # spaces per unit of measurement (% Required Spaces in Enclosed Facility / % Required Spaces in Fixed Facility)</del>							APPLICABLE USE LIMITATIONS D-AS-12+ D-AS-20+ D-CPV-T D-CPV-R D-CPV-C
		D-C	D-TD	D-LD	D-CV	D-GT D-AS		
Retail Sales, Service & Repair (Not Including Vehicle or Equipment Sales, Service & Repair)	Pawn Shop • <del>D-AS Districts - Vehicle: 1.25/1,000 s.f. GFA</del> • <del>D-GT, D-AS, &amp; D-AS-12+/20+ Districts - Bicycle: 1/7,500 s.f. GFA (20/80)</del> • <del>D-CPV-T/R/C Districts - Bicycle: 1/4,000 s.f. GFA (20/80)</del>	L-ZP	L-ZP	NP	NP	L-ZPIN	L-ZPIN	§11.4.15
	Retail Sales, Service & Repair -- Outdoor*	NP	NP	NP	NP	NP	NP	
	Retail Sales, Service & Repair - Firearms Sales	NP	NP	NP	NP	NP	NP	
	Retail Sales, Service & Repair, All Others • <del>D-AS Districts - Vehicle: 1.25/1,000 s.f. GFA</del> • <del>D-GT, D-AS, &amp; D-AS-12+/20+ Districts - Bicycle: 1/7,500 s.f. GFA (20/80)</del> • <del>D-CPV-T/R/C Districts - Bicycle: 1/4,000 s.f. GFA (20/80)</del>	P-ZP	P-ZP	P-ZP	NP	P-ZP	P-ZP	
Vehicle / Equipment Sales, Rentals, Service & Repair	Automobile Emissions Inspection Facility • <del>D-AS Districts - Vehicle: .5/1,000 s.f. GFA</del> • <del>D-GT, D-AS, D-AS-12+/20+ &amp; D-CPV-T/R/C Districts - Bicycle: No requirement</del>	L-ZP	L-ZP	NP	NP	L-ZP	NP	§ 11.4.17
	Automobile Services, Light • <del>D-AS Districts - Vehicle: .5/1,000 s.f. GFA</del> • <del>D-GT, D-AS, D-AS-12+/20+ &amp; D-CPV-T/R/C Districts - Bicycle: No requirement</del>	NP	NP	NP	NP	L-ZPIN	L-ZP	§11.4.18; §11.4.19
	Automobile Services, Heavy	NP	NP	NP	NP	NP	NP	
	Automobile / Motorcycle / Light Truck Sales, Rentals, Leasing; Pawn Lot or Vehicle Auctioneer* • <del>D-AS Districts - Vehicle: .5/1,000 s.f. GFA</del> • <del>D-GT, D-AS, D-AS-12+/20+ &amp; D-CPV-T/R/C Districts - Bicycle: No requirement</del>	L-ZP	L-ZP	L-ZP	NP	L-ZPIN	L-ZP	§11.4.21
	Heavy Vehicle/ Equipment Sales, Rentals & Service*	NP	NP	NP	NP	NP	NP	
<b>INDUSTRIAL, MANUFACTURING &amp; WHOLESALE PRIMARY USE CLASSIFICATION</b>								
Communications and Information	Antennas Not Attached to a Tower* • <del>Bicycle: No Parking Requirements</del>	L-ZP	L-ZP	L-ZP	L-ZP	L-ZP	L-ZP	§11.5.2
	Communication Services • <del>D-AS Districts - Vehicle: .5/1,000 s.f. GFA</del> • <del>D-GT, D-AS, D-AS-12+/20+ &amp; D-CPV-T/R/C Districts - Bicycle: No requirement</del>	L-ZP	L-ZP	L-ZP	L-ZP	L-ZP	L-ZP	§11.5.1
	Telecommunications Towers* • <del>Bicycle: No Parking Requirements</del>	L-ZP/ ZPIN/ ZPSE	L-ZP/ ZPIN/ ZPSE	L-ZP/ ZPIN/ ZPSE	L-ZP/ZPIN/ ZPSE	L-ZP/ZPIN/ ZPSE	L-ZP/ ZPIN/ ZPSE	§11.5.2
	Telecommunications Tower - Alternative Structure* • <del>Bicycle: No Parking Requirements</del>	L-ZP/ ZPIN	L-ZP/ ZPIN	L-ZP/ ZPIN	L-ZP/ZPIN	L-ZP/ZPIN	L-ZP/ZPIN	§11.5.2
	Telecommunication Facilities -- All Others* • <del>Bicycle: No Parking Requirements</del>	L-ZPIN	L-ZPIN	L-ZPIN	L-ZPIN	L-ZPIN	L-ZPIN	§11.5.2

KEY: \* = Need Not be Enclosed P = Permitted Use without Limitations L = Permitted Use with Limitations NP = Not Permitted Use ZP = Zoning Permit Review  
 ZPCIM = Subject to Zoning Permit Review with Community Information Meeting ZPIN = Subject to Zoning Permit Review with Informational Notice  
 ZPSE = Subject to Zoning Permit with Special Exception Review When no ZP, ZPCIM, ZPIN, ZPSE listed = No Zoning Permit required

USE CATEGORY	SPECIFIC USE TYPE D-C, D-TD, D-CV, D-GT, D-A5-12+/20+, D-LD, D-CPV-T/R/C Districts have no minimum vehicle parking requirement. D-CPV-T/R/C maximum vehicle parking requirements are provided in Section 8.11.5. D-C, D-TD, D-CV bicycle parking requirements are provided in Section 8.3.1.5. • Vehicle Parking Reqmt: # spaces per unit of measurement • Bicycle Parking Reqmt Requirement: # spaces per unit of measurement (% Required Spaces in Enclosed Facility / % Required Spaces in Fixed Facility)							APPLICABLE USE LIMITATIONS  D-AS-12+ D-AS-20+ D-CPV-T D-CPV-R D-CPV-C
		D-C	D-TD	D-LD	D-CV	D-GT D-AS		
Industrial Services	Contractors, Special Trade - General • D-AS Districts - Vehicle: .5/1,000 s.f. GFA • Bicycle: No requirement	L-ZP	L-ZP	L-ZP	NP	L-ZP	L-ZP	§11.5.3
	Contractors, Special Trade - Heavy/ Contractor Yard*	NP	NP	NP	NP	NP	NP	
	Food Preparation and Sales, Commercial • D-AS Districts - Vehicle: .5/1,000 s.f. GFA • Bicycle: No requirement	L-ZP	L-ZP	L-ZP	NP	L-ZP	L-ZP	§ 11.5.5
Industrial Services	Laboratory, Research, Development and Technological Services • D-AS Districts - Vehicle: .5/1,000 s.f. GFA • Bicycle: No requirement	L-ZP	L-ZP	L-ZP	NP	L-ZP	L-ZP	§11.5.6
	Service/Repair, Commercial • D-AS Districts - Vehicle: .5/1,000 s.f. GFA • Bicycle: No requirement	L-ZP	L-ZP	L-ZP	NP	L-ZP	L-ZP	§11.5.7
Manufacturing and Production	Manufacturing, Fabrication & Assembly -- Custom • D-AS Districts - Vehicle: .5/1,000 s.f. GFA • Bicycle: No requirement	L-ZP	L-ZP	L-ZP	NP	L-ZP	L-ZP	§11.5.8
	Manufacturing, Fabrication & Assembly -- General • D-AS Districts - Vehicle: .5/1,000 s.f. GFA • Bicycle: No requirement	L-ZP/ ZPSE	L-ZP/ ZPSE	L-ZPIN/ ZPSE	NP	L-ZPIN/ZPSE	L-ZP/ZPSE	§11.5.9
	Manufacturing, Fabrication & Assembly -- Heavy	NP	NP	NP	NP	NP	NP	
Mining & Extraction and Energy Producing Systems	Oil, Gas -- Production, Drilling*	NP	NP	NP	NP	NP	NP	
	Sand or Gravel Quarry*	NP	NP	NP	NP	NP	NP	
	Wind Energy Conversion Systems* • Bicycle: No Parking Requirements	L-ZP	L-ZP	L-ZP	L-ZP	L-ZP	L-ZP	§11.5.13
Transportation Facilities	Airport*	NP	NP	NP	NP	NP	NP	
	Helipad, Helistop, Heliport* • Bicycle: No Parking Requirements	L-ZP	L-ZP	NP	L-ZP	L-ZP/ZPSE	L-ZP	§11.5.14
	Railroad Facilities* • D-AS Districts - Vehicle: .5/1,000 s.f. GFA • Bicycle: No requirement	L-ZP	L-ZP	NP	L-ZP	L-ZP	NP	§11.5.15
	Railway Right-of-Way* • Bicycle: No Parking Requirements	P-ZP	P-ZP	P-ZP	P-ZP	P-ZP	P-ZP	
	Terminal, Station or Service Facility for Passenger Transit System • D-AS Districts - Vehicle: .5/1,000 s.f. GFA • Bicycle: No requirement	P-ZP	P-ZP	P-ZP	P-ZP	P-ZP	P-ZP	
	Terminal, Freight, Air Courier Services • D-AS Districts - Vehicle: .5/1,000 s.f. GFA • Bicycle: No requirement	L-ZP	L-ZP	L-ZP	L-ZP	L-ZPIN	NP	§ 11.5.17
Waste Related Services	Automobile Parts Recycling Business*	NP	NP	NP	NP	NP	NP	
	Junkyard*	NP	NP	NP	NP	NP	NP	
	Recycling Center	NP	NP	NP	NP	NP	NP	
	Recycling Collection Station	NP	NP	NP	NP	NP	NP	
	Recycling Plant, Scrap Processor	NP	NP	NP	NP	NP	NP	
	Solid Waste Facility	NP	NP	NP	NP	NP	NP	

KEY: \* = Need Not be Enclosed P = Permitted Use without Limitations L = Permitted Use with Limitations NP = Not Permitted Use ZP = Zoning Permit Review  
 ZPCIM = Subject to Zoning Permit Review with Community Information Meeting ZPIN = Subject to Zoning Permit Review with Informational Notice  
 ZPSE = Subject to Zoning Permit with Special Exception Review When no ZP, ZPCIM, ZPIN, ZPSE listed = No Zoning Permit required

USE CATEGORY	SPECIFIC USE TYPE <del>D-C, D-TD, D-CV, D-GT, D-A5-12+/20+, D-LD, D-CPV-T/R/C Districts have no minimum vehicle parking requirement. D-CPV-T/R/C maximum vehicle parking requirements are provided in Section 8.11.5. D-C, D-TD, D-CV bicycle parking requirements are provided in Section 8.3.1.5.</del> <ul style="list-style-type: none"> <li><del>Vehicle Parking Reqmt: # spaces per unit of measurement</del></li> <li><del>Bicycle Parking Reqmt Requirement: # spaces per unit of measurement (% Required Spaces in Enclosed Facility / % Required Spaces in Fixed Facility)</del></li> </ul>							APPLICABLE USE LIMITATIONS  D-AS-12+ D-AS-20+ D-CPV-T D-CPV-R D-CPV-C
		D-C	D-TD	D-LD	D-CV	D-GT D-AS		
Wholesale, Storage, Warehouse & Distribution	Automobile Towing Service Storage Yard*	NP	NP	NP	NP	NP	NP	
	Mini-storage Facility <ul style="list-style-type: none"><li><del>D-AS Districts - Vehicle: 0.1/1,000 s.f. GFA</del></li><li><del>Bicycle: No requirement</del></li></ul>	L-ZP	L-ZP	L-ZP	NP	L-ZP	L-ZP	§11.5.23
	Vehicle Storage, Commercial* <ul style="list-style-type: none"><li><del>D-AS Districts - Vehicle: 5/1,000 s.f. GFA</del></li><li><del>Bicycle: No requirement</del></li></ul>	L-ZP/ ZPSE	L-ZP/ ZPSE	L-ZP/ ZPSE	L-ZP/ ZPSE	L-ZP/ ZPSE	L-ZP/ ZPSE	§ 11.5.24
	Wholesale Trade or Storage, General	NP	NP	NP	NP	NP	NP	
	Wholesale Trade or Storage, Light <ul style="list-style-type: none"><li><del>D-AS Districts - Vehicle: 5/1,000 s.f. GFA</del></li><li><del>Bicycle: No requirement</del></li></ul>	P-ZP	P-ZP	P-ZP	NP	P-ZP	L-ZP/ ZPIN/ ZPSE	§ 11.5.26
<b>AGRICULTURE PRIMARY USE CLASSIFICATION</b>								
Agriculture	Aquaculture*	NP	NP	NP	NP	NP	NP	
	Garden, Urban* <ul style="list-style-type: none"><li><del>D-AS Districts - Vehicle: 5/1,000 s.f. GFA</del></li><li><del>Bicycle: No requirement</del></li></ul>	L-ZP	L-ZP	L-ZP	L-ZP	L-ZP	L-ZP	§ 11.6.2
	Husbandry, Animal*	NP	NP	NP	NP	NP	NP	
	Husbandry, Plant*	NP	NP	NP	NP	NP	NP	
	Plant Nursery <ul style="list-style-type: none"><li><del>D-AS Districts - Vehicle: 5/1,000 s.f. GFA</del></li><li><del>Bicycle: No requirement</del></li></ul>	L-ZP	L-ZP	L-ZP	L-ZP	L-ZP	L-ZP	§ 11.6.5

KEY: \* = Need Not be Enclosed P = Permitted Use without Limitations L = Permitted Use with Limitations NP = Not Permitted Use ZP = Zoning Permit Review  
 ZPCIM = Subject to Zoning Permit Review with Community Information Meeting ZPIN = Subject to Zoning Permit Review with Informational Notice  
 ZPSE = Subject to Zoning Permit with Special Exception Review When no ZP, ZPCIM, ZPIN, ZPSE listed = No Zoning Permit required

USE CATEGORY	SPECIFIC USE TYPE D-C, D-TD, D-CV, D-GT, D-A5-12+/20+, D-LD, D-CPV-T/R/C Districts have no minimum vehicle parking requirement. D-CPV-T/R/C maximum vehicle parking requirements are provided in Section 8.11.5. D-C, D-TD, D-CV bicycle parking requirements are provided in Section 8.3.1.5. • Vehicle Parking Reqmt: # spaces per unit of measurement • Bicycle Parking Reqmt Requirement: # spaces per unit of measurement (% Required Spaces in Enclosed Facility / % Required Spaces in Fixed Facility)							APPLICABLE USE LIMITATIONS  D-AS-12+ D-AS-20+ D-CPV-T D-CPV-R D-CPV-C
		D-C	D-TD	D-LD	D-CV	D-GT D-AS		

**ACCESSORY TO PRIMARY RESIDENTIAL USES USE CLASSIFICATION**

Accessories to Primary Residential Uses  (Parking is Not Required for Accessory Uses Unless Specifically Stated in this Table or in an Applicable Use Limitation)	Unlisted Accessory Uses	L - Applicable to all Zone Districts						\$11.7
		L-ZP	L-ZP	L-ZP	NP	L-ZP	L-ZP	
Accessory Dwelling Unit	L-ZP	L-ZP	L-ZP	NP	L-ZP	L-ZP	\$11.7; \$11.8.2	
Domestic Employees	L	L	L	NP	L	L	\$11.7.1; \$11.8.3	
Garden*	L	L	L	NP	L	L	\$11.7; \$11.8.4	
Keeping of Household Animals*	L/L-ZPIN	L/L-ZPIN	L/L-ZPIN	NP	L/L-ZPIN	L/L-ZPIN	\$11.7; \$11.8.5	
Keeping and Off-Street Parking of Vehicles, Motorcycles, Trailers & Recreational Vehicles*	L	L	L	NP	L	L	\$11.7; \$10.9	
Kennel or Exercise Run*	L	L	L	NP	L	L	\$11.7; \$11.8.6	
Limited Commercial Sales, Services Accessory to Multi-Unit Dwelling Use	Not Applicable - See Permitted Primary Uses						\$11.7; \$11.8.7	
Outdoor Storage, Residential*	L	L	L	L	L	L	\$11.7; \$11.8.8	
Second Kitchen Accessory to Single Unit Dwelling Use	L-ZP	L-ZP	L-ZP	NP	L-ZP	L-ZP	\$11.7; \$11.8.9	
Short-term Rental	L	L	L	NP	L	L	\$11.7; \$11.8.10	
Vehicle Storage, Repair and Maintenance*	L	L	L	NP	L	L	\$11.7; \$10.9	
Wind Energy Conversion Systems*	Not Applicable - See Permitted Primary Uses							
Yard or Garage Sales*	L	L	L	NP	L	L	\$11.7; \$11.8.11	

**HOME OCCUPATIONS ACCESSORY TO PRIMARY RESIDENTIAL USES USE CLASSIFICATION**

Home Occupations Accessory to a Primary Residential Use  (Parking is Not Required for Home Occupations Unless Specifically Stated in this Table or in an Applicable Use Limitation)	Child Care Home, Large	L-ZP	L-ZP	L-ZP	NP	L-ZP	L-ZP	\$11.9; \$11.9.3
	All Other Types	L-ZP	L-ZP	L-ZP	NP	L-ZP	L-ZP	\$11.9; \$11.9.4
Unlisted Home Occupations	L-ZPIN	L-ZPIN	L-ZPIN	NP	L-ZPIN	L-ZPIN	\$11.9; \$11.9.5	

**Modernizing Parking Requirements  
LUTI Committee Review Draft  
May 13, 2025**

Article 8. Downtown Neighborhood Context  
Division 8.11 Uses and Minimum/Maximum Parking Requirements

KEY: \* = Need Not be Enclosed P = Permitted Use without Limitations L = Permitted Use with Limitations NP = Not Permitted Use ZP = Zoning Permit Review  
ZPCIM = Subject to Zoning Permit Review with Community Information Meeting ZPIN = Subject to Zoning Permit Review with Informational Notice  
ZPSE = Subject to Zoning Permit with Special Exception Review When no ZP, ZPCIM, ZPIN, ZPSE listed = No Zoning Permit required

USE CATEGORY	SPECIFIC USE TYPE							APPLICABLE USE LIMITATIONS
	<p><del>D-C, D-TD, D-CV, D-GT, D-A5-12+/20+, D-LD, D-CPV-T/R/C Districts have no minimum vehicle parking requirement. D-CPV-T/R/C maximum vehicle parking requirements are provided in Section 8.11.5. D-C, D-TD, D-CV bicycle parking requirements are provided in Section 8.3.1.5.</del></p> <ul style="list-style-type: none"> <li><del>Vehicle Parking Reqmt: # spaces per unit of measurement</del></li> <li><del>Bicycle Parking Reqmt Requirement: # spaces per unit of measurement (% Required Spaces in Enclosed Facility / % Required Spaces in Fixed Facility)</del></li> </ul>							<p>D-AS-12+ D-AS-20+ D-CPV-T D-CPV-R D-CPV-C</p>
		D-C	D-TD	D-LD	D-CV	D-GT D-AS		

**ACCESSORY TO PRIMARY NONRESIDENTIAL USES USE CLASSIFICATION**

USE CATEGORY	SPECIFIC USE TYPE	L - Applicable to all Zone Districts						APPLICABLE USE LIMITATIONS	
		L-ZP	L-ZP	L-ZP	L-ZP	L-ZP	L-ZP		
Accessory to Primary Nonresidential Uses  (Parking is Not Required for Accessory Uses Unless Specifically Stated in this Table or in an Applicable Use Limitation)	Unlisted Accessory Uses	L - Applicable to all Zone Districts						§11.7; §11.10.1	
	Amusement Devices Accessory to Eating/Drinking Establishments, College/University and Theater Uses	L-ZP	L-ZP	L-ZP	L-ZP	L-ZP	L-ZP	§11.7; §11.10.2	
	Automobile Rental Services Accessory to Certain Retail Uses*	Not Applicable - See Permitted Primary Uses			NP	Not Applicable - See Permitted Primary Uses			
	Book or gift store; media recording and production facilities accessory to public libraries, museums, places of religious assembly, colleges or universities	L	L	L	L	L	L	§11.7; §11.10.4	
	Car Wash Bay Accessory to Automobile Services	NP	NP	NP	NP	NP	NP		
	College accessory to a Place for Religious Assembly	L	L	L	L	L	L	§11.7; §11.10.6	
	Conference Facilities Accessory to Hotel Use	L	L	L	L	L	L	§11.7; §11.10.7	
	Drive Through Facility Accessory to Eating/Drinking Establishments and to Retail Sales, Service, and Repair Uses*	NP	NP	NP	NP	L-ZP	NP	§11.7; §11.10.8	
	Emergency Vehicle Access Point	NP	NP	NP	NP	NP/L-ZPSE	NP	§11.7; §11.10.9	
	Garden*	L	L	L	L	L	L	§11.7; §11.10.10	
	Keeping of Animals	L/ L-ZP/ L-ZPIN	L/ L-ZP/ L-ZPIN	L/ L-ZP/ L-ZPIN	L/ L-ZP/ L-ZPIN	L/ L-ZP/ L-ZPIN	L/ L-ZP/ L-ZPIN	§11.7; §11.10.11	
	Limited Commercial Sales, Services	L	L	L	L	L	L	§11.7; §11.10.12	
	Nonresidential Uses in Existing Business Structures In Residential Zones - Accessory Uses	Not Applicable							
	Occasional Sales, Services Accessory to Primary Places of Religious Assembly or Primary Uses Operated by Nonprofit Organizations*	L	L	L	L	L	L	§11.7; §11.10.13	
	Outdoor Gathering Area*	L/L-ZP/ L-ZPIN	L/L-ZP/ L-ZPIN	L/L-ZP/ L-ZPIN	L/L-ZP/ L-ZPIN	L/L-ZP/ L-ZPIN	L/L-ZP/ L-ZPIN	§11.7; §11.10.14	
	Outdoor Entertainment Accessory to an Eating/Drinking Establishment Use*	L-ZPIN/ ZPSE	L-ZPIN/ ZPSE	L-ZPIN/ ZPSE	L-ZPIN/ ZPSE	L-ZPIN/ ZPSE	L-ZPIN/ ZPSE	§11.7; §11.10.15	
	Outdoor Retail Sale and Display*	L-ZP/ ZPSE	L-ZP/ ZPSE	L-ZP/ ZPSE	L-ZP/ ZPSE	L-ZP/ ZPSE	L-ZP/ ZPSE	§11.7; §11.10.16	
	Outdoor Storage, General*	NP	NP	NP	NP	NP	NP		
Outdoor Storage, Limited*	L	L	L	L	L	L	§11.7; §11.10.18		
Rental or Sales of Adult Material Accessory to a Permitted Bookstore Retail Sales Use	L	L	L	L	L	L	§11.7; §11.10.20		
Retail Food Establishment, Mobile (Food Truck)*	L-ZP	L-ZP	L-ZP	L-ZP	L-ZP	L-ZP	§11.7; §11.10.19		

KEY: \* = Need Not be Enclosed P = Permitted Use without Limitations L = Permitted Use with Limitations NP = Not Permitted Use ZP = Zoning Permit Review  
ZPCIM = Subject to Zoning Permit Review with Community Information Meeting ZPIN = Subject to Zoning Permit Review with Informational Notice  
ZPSE = Subject to Zoning Permit with Special Exception Review When no ZP, ZPCIM, ZPIN, ZPSE listed = No Zoning Permit required

USE CATEGORY	SPECIFIC USE TYPE							APPLICABLE USE LIMITATIONS
	<p><del>D-C, D-TD, D-CV, D-GT, D-A5-12+/20+, D-LD, D-CPV-T/R/C Districts have no minimum vehicle parking requirement. D-CPV-T/R/C maximum vehicle parking requirements are provided in Section 8.11.5. D-C, D-TD, D-CV bicycle parking requirements are provided in Section 8.3.1.5.</del></p> <ul style="list-style-type: none"> <li><del>Vehicle Parking Reqmt: # spaces per unit of measurement</del></li> <li><del>Bicycle Parking Reqmt Requirement: # spaces per unit of measurement (% Required Spaces in Enclosed Facility / % Required Spaces in Fixed Facility)</del></li> </ul>							<p>D-AS-12+ D-AS-20+ D-CPV-T D-CPV-R D-CPV-C</p>
		D-C	D-TD	D-LD	D-CV	D-GT D-AS		

TEMPORARY USE CLASSIFICATION

Temporary Uses	Unlisted Temporary Uses	L - Applicable to all Zone Districts						§11.11.1
		Not Applicable - See Permitted Primary Uses						§11.11.2
(Parking is Not Required for Temporary Uses Unless Specifically Stated in this Table or in an Applicable Use Limitation)	Ambulance Service - Temporary							
	Amusement / Entertainment - Temporary*	NP	NP	NP	NP	NP	NP	
	Bazaar, Carnival, Circus or Special Event*	L-ZP	L-ZP	L-ZP	L-ZP	L-ZP	L-ZP	§11.11.4
	Building or yard for construction materials*	L-ZP	L-ZP	L-ZP	L-ZP	L-ZP	L-ZP	§11.11.5
	Concrete, Asphalt, and Rock Crushing Facility*	L-ZP	L-ZP	L-ZP	L-ZP	L-ZP	L-ZP	§11.11.6
	Fence for Demolition or Construction Work	L-ZP	L-ZP	L-ZP	L-ZP	L-ZP	L-ZP	§11.11.7
	Health Care Center	P-ZP	P-ZP	P-ZP	P-ZP	P-ZP	L-ZP	§11.11.8
	Noncommercial Concrete Batching Plant*	L-ZP	L-ZP	L-ZP	L-ZP	L-ZP	L-ZP	§11.11.9
	Outdoor Retail Sales - Pedestrian / Transit Mall*	L-ZP	L-ZP	L-ZP	NP	NP	L-ZP	§11.11.10
	Outdoor Retail Sales*	NP	NP	NP	NP	NP	NP	
	Outdoor Sales, Seasonal*	L-ZP	L-ZP	L-ZP	L-ZP	L-ZP	L-ZP	§11.11.12
	Parking Lot Designated for a Special Event*	L-ZP	L-ZP	L-ZP	L-ZP	L-ZP	L-ZP	§11.11.13
	Retail Food Establishment, Mobile (Food Truck)*	L/L-ZP	L/L-ZP	L/L-ZP	NP	NP	L/L-ZP	§11.11.14
	Temporary Construction Office	L-ZP	L-ZP	L-ZP	L-ZP	L-ZP	L-ZP	§11.11.15
	Temporary Office - Real Estate Sales	L-ZP	L-ZP	L-ZP	L-ZP	L-ZP	L-ZP	§11.11.16
Temporary Managed Community*	L-ZPCIM	L-ZPCIM	L-ZPCIM	L-ZPCIM	L-ZPCIM	L-ZPCIM	§11.11.17	
Tent for Religious Services	NP	NP	NP	NP	NP	NP		

## SECTION 8.11.5 ~~MAXIMUM VEHICLE PARKING REQUIREMENTS FOR DOWNTOWN CENTRAL PLATTE VALLEY—AURARIA TRANSITION, RIVER AND CENTER DISTRICTS~~

### A. Intent

- To promote active, transit-supportive development that leverages the regional transit infrastructure investment in the Downtown Central Platte Valley - Auraria districts.
- To reduce the number of vehicle trips within and around the Downtown Central Platte Valley - Auraria districts and encourage alternative travel modes such as walking, biking, and transit.
- To promote the efficient development of land in the Downtown Central Platte Valley - Auraria districts by limiting the amount of land dedicated to vehicle parking.

### B. Applicability

This Section 8.11.5 applies to all Structures in the D-CPV-T, D-CPV-R and D-CPV-C zone districts.

### C. Vehicle Parking Standards

The following table establishes the maximum vehicle parking allowed in the D-CPV-T, D-CPV-R and D-CPV-C zone districts based on the allowed primary uses by zone district.

USE CATEGORY	SPECIFIC USE TYPE	MAXIMUM VEHICLE PARKING: # SPACES PER UNIT OF MEASUREMENT
<b>RESIDENTIAL PRIMARY USE CLASSIFICATION</b>		
Household Living	Dwelling, Single Unit	No Maximum
	Dwelling, Two Unit	No Maximum
	All other specific use types within the Household Living Use Category	0.7/Unit for each unit with 0-1 bedrooms 1.0/Unit for each unit with 2 bedrooms 1.3/Unit for each unit with 3+ bedrooms
Group Living Residential Care	Residence for Older Adults All Types with units that have individual bedrooms	0.7/Unit for each unit with 0-1 bedrooms 1.0/Unit for each unit with 2 bedrooms 1.3/Unit for each unit with 3+ bedrooms
	Rooming and Boarding House All Other Types	1.25/1,000-sf GFA
	Shelter for the Homeless	1.25/1,000-sf GFA
	All other specific use types within the Group Living Use Category	0.7/Unit
Congregate Living	All Types with units that have individual bedrooms	0.7/Unit
	All Other Types	1.25/1,000-sf GFA
<b>CIVIC, PUBLIC &amp; INSTITUTIONAL PRIMARY USE CLASSIFICATION</b>		
-	All specific use types within the Civic, Public & Institutional Primary Use Classification	1.25/1,000-sf GFA
<b>COMMERCIAL SALES, SERVICE &amp; REPAIR PRIMARY USE CLASSIFICATION</b>		
Arts, Recreation & Entertainment	Arts, Recreation and Entertainment Services, Indoor	1.25/1,000-sf GFA
	Arts, Recreation and Entertainment Services, Outdoor	6.0/1,000-sf GFA
	Sports and/or Entertainment Arena or Stadium	6.0/1,000-sf GFA
Parking of Vehicles	Parking, Garage	No Maximum*
Eating & Drinking Establishments	All Types	2.0/1,000-sf GFA
Lodging Accommodations	Bed and Breakfast Lodging	0.5/guest room or unit
	Lodging Accommodations, All Others	0.5/guest room or unit
	All other specific use types within the Commercial Sales, Service, & Repair Primary Use Classification	1.25/1,000-sf GFA
<b>INDUSTRIAL, MANUFACTURING &amp; WHOLESALE PRIMARY USE CLASSIFICATION</b>		
Transportation Facilities	Terminal, Station or Service Facility for Passenger Transit System	No Maximum*
	All other specific use types within the Industrial, Manufacturing & Wholesale Primary Use Classification	1.25/1,000-sf GFA
<b>AGRICULTURE PRIMARY USE CLASSIFICATION</b>		
<b>8.11-14  </b>	<b>DENVER ZONING CODE</b> All specific use types within the Agriculture Primary Use Classification	1.25/1,000-sf GFA

\*See Section 10.4.5.4 for Shared Vehicle Parking Requirements

BUILDING FEATURES	ZONE DISTRICTS	THE AGGREGATE SHALL NOT EXCEED 33-1/3 PERCENT OF THE AREA OF THE SUPPORTING ROOF	SHALL BE SET BACK FROM THE PERIMETER OF THE BUILDING A MINIMUM OF ONE FOOT HORIZONTALLY FOR EVERY ONE FOOT OF VERTICAL HEIGHT	MAY EXCEED MAXIMUM HEIGHT IN FEET BY:	MAY EXCEED MAXIMUM HEIGHT IN STORIES BY:	MAY PROJECT THROUGH THE BULK PLANE	MAY EXCEED UPPER STORY SETBACK HEIGHT BY:
Parapet Wall or Safety Railing	All 5-Story or greater I-MX Zone Districts, I-A, I-B	No	No	Any distance	Not applicable	Not allowed	4'
Solar panels	All I- Zone Districts	No	No	Any distance	Not applicable	Any distance	Any distance
Evaporative coolers	All I- Zone Districts	No	Yes	Any distance	Not applicable	Any distance	Any distance
Accessory water tanks	All I- Zone Districts	No	Yes	28'	Not applicable	Any distance	Any distance
Pedestrian bridge	All I- Zone Districts	Not applicable	Not applicable	28'	Any number	Any distance	Any distance

### 9.1.7.2 Setback Exceptions - Architectural, Site, Service & Utility Elements

**A. Intent**

To allow minor elements to encroach into a setback while maintaining an open and unobstructed minimum setback.

**B. Standard**

Except as specifically allowed below, Setbacks specified in the applicable Building Form tables shall be open and unobstructed.

**C. Exceptions**

The following Structures or portions of Structures are permitted to encroach into the Setbacks subject to the limitations in the tables below. No portion of a Structure that encroaches into the Setbacks shall extend into a required Setback beyond the maximum Setback encroachment distance specified in the tables below, as measured perpendicular to the respective Zone Lot line. Where more than one Setback encroachment is allowed for the same Structure or portion of a Structure, the permitted Setback encroachment distances shall not be cumulative. See "Height Exceptions" for encroachments related to Upper Story Setbacks.

**1. Architectural Elements**

To allow for minor elements which add to the architectural character of buildings, while maintaining an open and unobstructed setback.



	ZONE DISTRICTS	BUILDING FORMS	PRIMARY STREET	SIDE STREET	SIDE INTERIOR	REAR
Surface Parking	All I- Zone Districts	All building forms	I-A and I-B: 10'; 15' when garden wall screening is provided following Section 10.5.4.4  I-MX: Not applicable	Not allowed	Not allowed	Any distance
Intent: To restrict surface parking where it is <b>more impactful due to the number of required parking spaces.</b>	<p style="text-align: right;"><i>Not to Scale. Illustrative Only.</i></p>					
	ZONE DISTRICTS	BUILDING FORMS	PRIMARY STREET	SIDE STREET	SIDE INTERIOR	REAR
Drive or Driveway	All I- Zone Districts	All building forms	Any distance	Any distance	Not allowed	Any distance
Intent: To allow a Drive or Driveway to access an Off-Street Parking Area, but restrict the location where it is impactful due to proximity to adjacent properties.	<p style="text-align: right;"><i>Not to Scale. Illustrative Only.</i></p>					
<p style="text-align: center;"><i>Illustrative only</i></p>						

## SECTION 9.1.9 USES ~~AND REQUIRED MINIMUM PARKING~~

### 9.1.9.1 Applicability

- A. This Section 9.1.9 sets forth the land uses permitted; ~~and the~~ required zoning procedures ~~and the required minimum parking~~ for all the Industrial Context zone districts.
- B. Uses not listed are prohibited, unless the Zoning Administrator specifically permits the unlisted use according to Section 12.4.6, Code Interpretations and Determination of Unlisted Uses.
- C. For number of primary and accessory uses allowed per Zone Lot, see Section 1.2.3.5, Number of Structures and Uses Allowed per Zone Lot.

### 9.1.9.2 Organization

#### A. Organized by Primary, Accessory and Temporary Uses

The Use ~~and Parking~~ Table first presents all primary uses, then all accessory uses, and finally all temporary uses. Primary uses are arranged hierarchically within the table by use classification, category of primary uses, and then by specific use type. Accessory uses are organized by whether such use is accessory to a primary residential use or to a primary nonresidential use. Temporary uses are presented alphabetically ordered in the last division of the table.

#### B. Primary Use Classifications, Categories & Specific Use Types

##### 1. Primary Use Classifications

All primary land uses in the Use ~~and Parking~~ Table are organized into one of the following five general land use classifications:

- a. Residential Uses
- b. Civic, Public & Institutional Uses
- c. Commercial Sales, Service & Repair Uses
- d. Industrial, Manufacturing & Wholesale Uses
- e. Agriculture

##### 2. Primary Use Categories & Specific Use Types

Primary uses are further organized into use categories and specific use types listed under each general primary land use classification. The Use ~~and Parking~~ Table is organized into the above five general land use classifications, use categories and specific use types.

##### 3. Classifications & Categories Are Mutually Exclusive

The general land use classifications and use categories listed in the Use ~~and Parking~~ Table are intended to be mutually exclusive; that is, a use classified into one use category, such as “lodging accommodations,” cannot be classified in a different use category, such as “congregate living,” unless otherwise expressly allowed by this Code.

### 9.1.9.3 Explanation of Table Abbreviations

#### A. General Explanation of Table Cell Entries

In each of the table cells, the entry will indicate first whether use limitations apply to the specific use, and then separated by a hyphen, the type of zoning review required prior to establishment of the use under this Code. For example, as described in more detail below, a cell entry “L-ZPIN” means, first, the use is subject to use standards and limitations (the “L”), and, second, that the use is subject to zoning permit review with information notice (the “ZPIN”) prior to its establishment.

#### B. Permitted, Limited, Not Permitted

##### 1. Permitted Use - No Use Limitations Apply (“P”)

A “P” in a table cell indicates that the use is permitted in the respective zone district, and is not subject to use limitations.

- 2. Permitted Use - Subject to Use Limitations (“L”)**  
“L” in a table cell indicates the use is permitted in the zone district subject to compliance with the use limitations referenced in the last column of the use table (“Applicable Use Limitations”).
- 3. Uses Not Permitted (“NP”)**  
“NP” in a table cell indicates that the use is not permitted in the specific zone district.
- 4. Zoning Procedure Use Subject to Zoning Permit Review (“ZP”)**  
“ZP” in a table cell indicates that the use is permitted in the respective zone district only if reviewed and approved according to the requirements in Section 12.4.1, Zoning Permit Review.
- 5. Use Subject to Zoning Permit Review with Informational Notice (“ZPIN”)**  
“ZPIN” in a table cell indicates that the use is permitted in the respective zone district only if reviewed and approved according to the public notice and procedural requirements in Section 12.4.2, Zoning Permit Review with Informational Notice. Such uses shall comply with any applicable use limitations noted in the last column of the use table (“Applicable Use Limitations”), as well as the review criteria stated in Section 12.4.2, Zoning Permit Review with Informational Notice.
- 6. Use Subject to Zoning Permit Review with Community Information Meeting (“ZPCIM”)**  
“ZPCIM” in a table cell indicates that the use is permitted in the respective zone district only if reviewed and approved according to the public notice and procedural requirements in Section 12.4.1, Zoning Permit Review. Prior to formal application, an applicant shall schedule a community information meeting and provide public notice of the community information meeting according to Section 12.3.4.6, Community Information Meeting.
- 7. Use Subject to Zoning Permit with Special Exception Review (“ZPSE”)**  
“ZPSE” in a table cell indicates that use is generally appropriate in the neighborhood context and zone district, yet may have the potential for limited impacts on adjacent properties or on the established character of the neighborhood context or zone district. “ZPSE” uses are subject to a Board of Adjustments public hearing according to Section 12.4.9, Zoning Permit with Special Exception Review, which grants the Board of Adjustment the authority to impose conditions on the specified use to mitigate any potential impacts. Such uses shall comply with any applicable use limitations noted in the last column of the use table (“Applicable Use Limitations”), as well as the review criteria stated in Section 12.4.9, Zoning Permit with Special Exception Review.
- 8. Uses Where More Than One Zoning Procedure Is Indicated**  
Where a table cell shows more than one zoning procedure applies to a use, for example “L-ZP/ZPIN”, the referenced use limitation (last table column) will indicate which zoning procedure applies in a specific case. For example, a table cell may indicate “L-ZPIN/ZPSE” for a use. This means that the ZPIN zoning procedure will apply, unless the applicable use limitation specifies the ZPSE zoning procedure is triggered (e.g., by proximity to a Protected District).

#### 9.1.9.4 Enclosure of Uses

All primary, accessory and temporary uses must be established, operated and maintained within a Completely Enclosed Structure, unless otherwise specifically allowed by this Code. The Use ~~and~~ **Parking** Tables in Articles 3-9 indicate when a use may be established, operated or maintained outside a Completely Enclosed Structure by including an asterisk “\*” next to the specific use type. For example, the asterisk following the “Telecommunication Tower\*” use type in the tables indicates that a telecommunication tower land use need not be enclosed.

### 9.1.9.5 District Specific Standards

KEY: \* = Need Not be Enclosed P = Permitted Use without Limitations L = Permitted Use with Limitations NP = Not Permitted Use  
 ZP = Zoning Permit Review ZPCIM = Subject to Zoning Permit Review with Community Information Meeting  
 ZPIN = Subject to Zoning Permit Review with Informational Notice ZPSE = Subject to Zoning Permit with Special Exception Review  
 When no ZP, ZPIN, ZPCIM, ZPSE listed = No Zoning Permit required

USE CATEGORY	SPECIFIC USE TYPE <ul style="list-style-type: none"> <li>• <del>Vehicle Parking Requirement – # of spaces per unit of measurement</del></li> <li>• <del>Bicycle Parking Requirement – # of spaces per unit of measurement (% required spaces in indoor facility/% required spaces in fixed facility)</del></li> </ul>	I-MX-3 I-MX-5 I-MX-8 I-MX-12	I-A	I-B	APPLICABLE USE LIMITATIONS
<b>RESIDENTIAL PRIMARY USE CLASSIFICATION</b>					
Household Living	Dwelling, Single Unit • <del>No Parking Requirements:</del>	L-ZP	L-ZP	L-ZP	§11.2.1, §11.2.7
	Dwelling, Two Unit • <del>Vehicle – 1/MX only: 1/unit</del> • <del>Vehicle: 1.25/unit</del> • <del>Bicycle: No requirement</del>	L-ZP	L-ZP	L-ZP	§11.2.2, §11.2.7
	Dwelling, Multi-Unit • <del>Vehicle – 1/MX only: 1/unit</del> • <del>Vehicle: 1.25/unit</del> • <del>Bicycle: 1/5 units (80/20)</del>	L-ZP	L-ZP	L-ZP	§11.2.3, §11.2.7
	Dwelling, Live / Work • <del>Vehicle – 1/MX only: 1/unit</del> • <del>Vehicle: 1.25/unit</del> • <del>Bicycle: 1/5 units (80/20)</del>	L-ZP	L-ZP	L-ZP	§11.2.4, §11.2.7
	Manufactured Home Community	NP	NP	NP	
Residential Care	Residential Care, Type 1 • <del>Vehicle – 1/MX only: .25/1,000 sf GFA</del> • <del>Vehicle: .5/1,000 sf GFA</del> • <del>Bicycle: No Requirement</del>	L/L-ZP	NP	NP	§11.2.8; §11.2.9
	Residential Care, Type 2 • <del>Vehicle – 1/MX only: .25/1,000 sf GFA</del> • <del>Vehicle: .5/1,000 sf GFA</del> • <del>Bicycle: No Requirement</del>	L-ZP	NP	NP	§11.2.8; §11.2.10
	Residential Care, Type 3 • <del>Vehicle – 1/MX only: .25/1,000 sf GFA</del> • <del>Vehicle: .5/1,000 sf GFA</del> • <del>Bicycle: No Requirement</del>	L-ZPCIM	L-ZPCIM	L-ZPCIM	§11.2.8; §11.2.11
	Residential Care, Type 4 • <del>Vehicle – 1/MX only: .25/1,000 sf GFA</del> • <del>Vehicle: .5/1,000 sf GFA</del> • <del>Bicycle: No Requirement</del>	L-ZPCIM	L-ZPCIM	L-ZPCIM	§11.2.8; §11.2.12
Congregate Living	All Types • <del>Vehicle – 1/MX only: .25/1,000 sf GFA</del> • <del>Vehicle: .5/1,000 sf GFA</del> • <del>Bicycle: 1/20,000 sf GFA (80/20)</del>	P-ZP	NP	NP	
<b>CIVIC, PUBLIC &amp; INSTITUTIONAL PRIMARY USE CLASSIFICATION</b>					
Basic Utilities	Utility, Major Impact* • <del>Vehicle: .5/1,000 s.f. GFA</del> • <del>Bicycle: No requirement</del>	L-ZPSE	L-ZPSE	L-ZPSE	§ 11.3.1
	Utility, Minor Impact* • <del>Vehicle: .5/1,000 s.f. GFA</del> • <del>Bicycle: No requirement</del>	L-ZP	L-ZP	L-ZP	§ 11.3.2

KEY: \* = Need Not be Enclosed P = Permitted Use without Limitations L = Permitted Use with Limitations NP = Not Permitted Use  
ZP = Zoning Permit Review ZPCIM = Subject to Zoning Permit Review with Community Information Meeting  
ZPIN = Subject to Zoning Permit Review with Informational Notice ZPSE = Subject to Zoning Permit with Special Exception Review  
When no ZP, ZPIN, ZPCIM, ZPSE listed = No Zoning Permit required

USE CATEGORY	SPECIFIC USETYPE • Vehicle Parking Requirement – # of spaces per unit of measurement • Bicycle Parking Requirement – # of spaces per unit of measurement (% required spaces in indoor facility/% required spaces in fixed facility)				APPLICABLE USE LIMITATIONS
		I-MX-3 I-MX-5 I-MX-8 I-MX-12	I-A	I-B	
Community/ Public Services	Community Center* • Vehicle: <del>5</del> /1,000 s.f. GFA • Bicycle: 1/10,000 s.f. GFA (0/100)	P-ZP	P-ZP	P-ZP	
	Day Care Center • Vehicle: 1/1,000 s.f. GFA • Bicycle: 1/10,000 s.f. GFA (0/100)	P-ZP	P-ZP	P-ZP	
	Postal Facility, Neighborhood • Vehicle – I-MX only: 1.875/1,000 s.f. GFA • Vehicle: 2.5/1,000 s.f. GFA • Bicycle: 1/20,000 s.f. GFA (20/80)	P-ZP	P-ZP	P-ZP	
	Postal Processing Center • Vehicle: 1/1,000 s.f. GFA • Bicycle: 1/20,000 s.f. GFA (20/80)	P-ZP	P-ZP	P-ZP	
	Public Safety Facility • Vehicle: 1/1,000 s.f. GFA • Bicycle: 1/10,000 s.f. GFA (0/100)	P-ZP	P-ZP	P-ZP	
	Hospital	NP	NP	NP	
	Correctional Institution	NP	NP	NP	
Cultural/Special Purpose/Public Parks & Open Space	Cemetery* • No Parking Requirements	L-ZP	L-ZP	L-ZP	§11.3.6
	Library • Vehicle: 1/1,000 s.f. GFA • Bicycle: 1/10,000 s.f. GFA (0/100)	P-ZP	P-ZP	NP	
	Museum • Vehicle: 1/1,000 s.f. GFA • Bicycle: 1/10,000 s.f. GFA (0/100)	P-ZP	P-ZP	P-ZP	
	City Park*	NP	NP	NP	
	Open Space - Conservation* • No Parking Requirements	P-ZP	P-ZP	P-ZP	
Education	Elementary or Secondary School • Vehicle – I-MX only: 1/1,000 s.f. GFA • Vehicle – High School, I-A and I-B: 2/1,000 s.f. GFA • Bicycle – High School, I-A and I-B: 1/20,000 s.f. GFA (0/100) • Vehicle – All Others, I-A and I-B: 1/1,000 s.f. GFA • Bicycle – All Others, I-A and I-B: 1/10,000 s.f. GFA (0/100)	L-ZP	L-ZP	NP	§ 11.3.8
	University or College • Vehicle: 1/1,000 s.f. GFA • Bicycle: 1/10,000 s.f. GFA (0/100)	L-ZP	L-ZP	L-ZP	§ 11.3.8
	Vocational or Professional School • Vehicle: 1/1,000 s.f. GFA • Bicycle: 1/10,000 s.f. GFA (0/100)	L-ZP	L-ZP	L-ZP	§ 11.3.8
Public and Religious Assembly	All Types • Vehicle: <del>5</del> /1,000 s.f. GFA • Bicycle: 1/10,000 s.f. GFA (0/100)	P-ZP	P-ZP	NP	

KEY: \* = Need Not be Enclosed P = Permitted Use without Limitations L = Permitted Use with Limitations NP = Not Permitted Use  
 ZP = Zoning Permit Review ZPCIM = Subject to Zoning Permit Review with Community Information Meeting  
 ZPIN = Subject to Zoning Permit Review with Informational Notice ZPSE = Subject to Zoning Permit with Special Exception Review  
 When no ZP, ZPIN, ZPCIM, ZPSE listed = No Zoning Permit required

USE CATEGORY	SPECIFIC USE TYPE <ul style="list-style-type: none"> <li>• <del>Vehicle Parking Requirement – # of spaces per unit of measurement</del></li> <li>• <del>Bicycle Parking Requirement – # of spaces per unit of measurement (% required spaces in indoor facility/% required spaces in fixed facility)</del></li> </ul>	I-MX-3 I-MX-5 I-MX-8 I-MX-12	I-A	I-B	APPLICABLE USE LIMITATIONS
<b>COMMERCIAL SALES, SERVICES, &amp; REPAIR PRIMARY USE CLASSIFICATION</b>					
Adult Business	All Types	NP	NP	NP	See Section 9.4.4, Use Overlay Districts, for adult business use allowance in the UO-1 District.
Arts, Recreation and Entertainment	Arts, Recreation and Entertainment Services, Indoor <ul style="list-style-type: none"> <li>• <del>Vehicle – Artist Studio: 0.3/1000 s.f. GFA</del></li> <li>• <del>Vehicle – All Others – I-MX only: 1.875/1,000 s.f. GFA</del></li> <li>• <del>Vehicle – All Others: 2.5/1,000 s.f. GFA</del></li> <li>• <del>Bicycle: 1/20,000 s.f. GFA (20/80)</del></li> </ul>	P-ZP	P-ZP	P-ZP	
	Arts, Recreation and Entertainment Services, Outdoor* <ul style="list-style-type: none"> <li>• <del>Vehicle – I-MX only: 1.875/1,000 s.f. GFA</del></li> <li>• <del>Vehicle: 2.5/1,000 s.f. GFA</del></li> <li>• <del>Bicycle: 1/20,000 s.f. GFA (20/80)</del></li> </ul>	L-ZP	L-ZP	L-ZP	\$11.4.3
	Event Space with Alternate Parking and Loading* <ul style="list-style-type: none"> <li>• <del>Vehicle: No requirement</del></li> <li>• <del>Bicycle: No requirement</del></li> </ul>	NP	NP	NP	
	Sports and/or Entertainment Arena or Stadium* <ul style="list-style-type: none"> <li>• <del>Vehicle: 2.5/1,000 s.f. GFA</del></li> <li>• <del>Bicycle: 1/20,000 s.f. GFA (20/80)</del></li> </ul>	L-ZP	L-ZP	L-ZP	\$11.4.5
Nonresidential Uses in Existing Business Structures In Residential Zones ( <del>All Uses Shall Be Parked According to the Parking Requirement Stated in this Use Table for the Specific Nonresidential Use</del> )		Not Applicable			
Parking of Vehicles	Parking, Garage <ul style="list-style-type: none"> <li>• <del>No Parking Requirements</del></li> </ul>	P-ZP	P-ZP	P-ZP	
	Parking, Surface* <ul style="list-style-type: none"> <li>• <del>No Parking Requirements</del></li> </ul>	P-ZP	P-ZP	P-ZP	
Eating & Drinking Establishments	All Types <ul style="list-style-type: none"> <li>• <del>Vehicle – I-MX only: 3.75/1,000 s.f. GFA</del></li> <li>• <del>Vehicle: 5/1,000 s.f. GFA</del></li> <li>• <del>Bicycle: 1/5,000 s.f. GFA (0/100)</del></li> </ul>	P-ZP	P-ZP	P-ZP	
Lodging Accommodations	Bed and Breakfast Lodging <ul style="list-style-type: none"> <li>• <del>Vehicle – I-MX only: 1/guest room or unit</del></li> <li>• <del>Vehicle: 1.25/guest room or unit</del></li> <li>• <del>Bicycle: 1/20,000 s.f. GFA (60/40)</del></li> </ul>	P-ZP	NP	NP	
	Lodging Accommodations, All Others <ul style="list-style-type: none"> <li>• <del>Vehicle – I-MX only: 1/guest room or unit</del></li> <li>• <del>Vehicle: 1.25/guest room or unit</del></li> <li>• <del>Bicycle: 1/20,000 s.f. GFA (60/40)</del></li> </ul>	P-ZP	P-ZP	P-ZP	
Office	Dental / Medical Office or Clinic <ul style="list-style-type: none"> <li>• <del>Vehicle – I-MX only: 1.875/1,000 s.f. GFA</del></li> <li>• <del>Vehicle: 2.5/1,000 s.f. GFA</del></li> <li>• <del>Bicycle: 1/20,000 s.f. GFA (60/40)</del></li> </ul>	L-ZP	L-ZP	L-ZP	\$11.4.10
	Office, All Others <ul style="list-style-type: none"> <li>• <del>Vehicle – I-MX only: 1.875/1,000 s.f. GFA</del></li> <li>• <del>Vehicle: 2/1,000 s.f. GFA</del></li> <li>• <del>Bicycle: 1/20,000 s.f. GFA (60/40)</del></li> </ul>	P-ZP	P-ZP	P-ZP	

KEY: \* = Need Not be Enclosed P = Permitted Use without Limitations L = Permitted Use with Limitations NP = Not Permitted Use  
ZP = Zoning Permit Review ZPCIM = Subject to Zoning Permit Review with Community Information Meeting  
ZPIN = Subject to Zoning Permit Review with Informational Notice ZPSE = Subject to Zoning Permit with Special Exception Review  
When no ZP, ZPIN, ZPCIM, ZPSE listed = No Zoning Permit required

USE CATEGORY	SPECIFIC USETYPE • <del>Vehicle Parking Requirement – # of spaces per unit of measurement</del> • <del>Bicycle Parking Requirement – # of spaces per unit of measurement (% required spaces in indoor facility/% required spaces in fixed facility)</del>	I-MX-3 I-MX-5 I-MX-8 I-MX-12			APPLICABLE USE LIMITATIONS
		I-A	I-B		
Retail Sales, Service & Repair (Not Including Vehicle or Equipment Sales, Service & Repair)	Animal Sales and Services, Household Pets Only • <del>Vehicle – I-MX only: 1.875/ 1,000 s.f. GFA</del> • <del>Vehicle: 2.5/ 1,000 s.f. GFA</del> • <del>Bicycle: 1/20,000 s.f. GFA (20/80)</del>	P-ZP	P-ZP	P-ZP	
	Animal Sales and Services, All Others • <del>Vehicle – I-MX only: 1.875/ 1,000 s.f. GFA</del> • <del>Vehicle: 2.5/ 1,000 s.f. GFA</del> • <del>Bicycle: 1/20,000 s.f. GFA (20/80)</del>	L-ZP	L-ZP	L-ZP	§11.4.13
	Food Sales or Market • <del>Vehicle – I-MX only: 1.875/ 1,000 s.f. GFA</del> • <del>Vehicle: 2.5/ 1,000 s.f. GFA</del> • <del>Bicycle: 1/20,000 s.f. GFA (20/80)</del>	L-ZP	P-ZP	P-ZP	§11.4.14
Retail Sales, Service & Repair (Not Including Vehicle or Equipment Sales, Service & Repair)	Pawn Shop	NP	NP	NP	
	Retail Sales, Service & Repair -- Outdoor* • <del>Vehicle – I-MX only: 1.875/ 1,000 s.f. GFA</del> • <del>Vehicle: 2.5/ 1,000 s.f. GFA</del> • <del>Bicycle: 1/20,000 s.f. GFA (20/80)</del>	L-ZP	L-ZP	L-ZP	§11.4.16; §11.4.11
	Retail Sales, Service & Repair - Firearms Sales • <del>Vehicle – I-MX only: 1.875/ 1,000 s.f. GFA</del> • <del>Vehicle: 2.5/ 1,000 s.f. GFA</del> • <del>Bicycle: 1/20,000 s.f. GFA (20/80)</del>	P-ZP	L-ZP	L-ZP	§11.4.11
	Retail Sales, Service & Repair, All Others • <del>Vehicle – I-MX only: 1.875/ 1,000 s.f. GFA</del> • <del>Vehicle: 2.5/ 1,000 s.f. GFA</del> • <del>Bicycle: 1/20,000 s.f. GFA (20/80)</del>	P-ZP	P-ZP	L-ZP	§11.4.11
Vehicle / Equipment Sales, Rentals, Service & Repair	Automobile Emissions Inspection Facility • <del>Vehicle: .5/ 1,000 s.f. GFA</del> • <del>Bicycle: No requirement</del>	P-ZP	P-ZP	P-ZP	
	Automobile Services, Light • <del>Vehicle: .5/ 1,000 s.f. GFA</del> • <del>Bicycle: No requirement</del>	L-ZP	L-ZP	L-ZP	§11.4.18; §11.4.19
	Automobile Services, Heavy • <del>Vehicle: .5/ 1,000 s.f. GFA</del> • <del>Bicycle: No requirement</del>	L-ZP/ZPSE	L-ZP/ZPSE	L-ZP/ZPSE	§11.4.18; §11.4.20
	Automobile / Motorcycle / Light Truck Sales, Rentals, Leasing; Pawn Lot or Vehicle Auctioneer* • <del>Vehicle: .5/ 1,000 s.f. GFA</del> • <del>Bicycle: No requirement</del>	L-ZP	L-ZP	L-ZP	§11.4.21
	Heavy Vehicle/ Equipment Sales, Rentals & Service* • <del>Vehicle: .5/ 1,000 s.f. GFA</del> • <del>Bicycle: No requirement</del>	L-ZPSE	L-ZPIN	L-ZP	§11.4.22

KEY: \* = Need Not be Enclosed P = Permitted Use without Limitations L = Permitted Use with Limitations NP = Not Permitted Use  
 ZP = Zoning Permit Review ZPCIM = Subject to Zoning Permit Review with Community Information Meeting  
 ZPIN = Subject to Zoning Permit Review with Informational Notice ZPSE = Subject to Zoning Permit with Special Exception Review  
 When no ZP, ZPIN, ZPCIM, ZPSE listed = No Zoning Permit required

USE CATEGORY	SPECIFIC USETYPE <ul style="list-style-type: none"> <li>• <del>Vehicle Parking Requirement – # of spaces per unit of measurement</del></li> <li>• <del>Bicycle Parking Requirement – # of spaces per unit of measurement (% required spaces in indoor facility/% required spaces in fixed facility)</del></li> </ul>	I-MX-3	I-MX-5	I-MX-8	I-MX-12	I-A	I-B	APPLICABLE USE LIMITATIONS
<b>INDUSTRIAL, MANUFACTURING &amp; WHOLESALE PRIMARY USE CLASSIFICATION</b>								
Communications and Information	Antennas Not Attached to a Tower* • <del>No Parking Requirements</del>	L-ZP	L-ZP	L-ZP				\$11.5.2
	Communication Services • <del>Vehicle: .3/ 1,000 s.f. GFA</del> • <del>Bicycle: No requirement</del>	P-ZP	P-ZP	P-ZP				
	Telecommunications Towers* • <del>Vehicle: .3/ 1,000 s.f. GFA</del> • <del>Bicycle: No requirement</del>	L-ZP/ZPIN/ ZPSE	L-ZP/ZPIN/ ZPSE	L-ZP/ZPIN/ ZPSE				\$11.5.2
	Telecommunications Tower - Alternative Structure • <del>Vehicle: .3/ 1,000 s.f. GFA</del> • <del>Bicycle: No requirement</del>	L-ZP/ZPIN	L-ZP/ZPIN	L-ZP/ZPIN				\$11.5.2
	Telecommunication Facilities -- All Others* • <del>Vehicle: .3/ 1,000 s.f. GFA</del> • <del>Bicycle: No requirement</del>	L-ZPIN	L-ZP	L-ZP				\$11.5.2
Industrial Services	Contractors, Special Trade - General • <del>Vehicle: .3/ 1,000 s.f. GFA</del> • <del>Bicycle: No requirement</del>	L-ZP	L-ZP	L-ZP				\$11.5.3
	Contractors, Special Trade - Heavy/ Contractor Yard* • <del>Vehicle: .3/ 1,000 s.f. GFA</del> • <del>Bicycle: No requirement</del>	L-ZP	L-ZP	L-ZP				\$11.5.4
	Food Preparation and Sales, Commercial • <del>Vehicle: .3/ 1,000 s.f. GFA</del> • <del>Bicycle: No requirement</del>	L-ZP	L-ZP	L-ZP				\$ 11.5.5
	Laboratory, Research, Development and Technological Services • <del>Vehicle: .3/ 1,000 s.f. GFA</del> • <del>Bicycle: No requirement</del>	L-ZP	L-ZP	L-ZP				\$11.5.6
	Service/Repair, Commercial • <del>Vehicle: .3/ 1,000 s.f. GFA</del> • <del>Bicycle: No requirement</del>	L-ZP	L-ZP	L-ZP				\$11.5.7
Manufacturing and Production	Manufacturing, Fabrication & Assembly -- Custom • <del>Vehicle: .3/ 1,000 s.f. GFA</del> • <del>Bicycle: No requirement</del>	L-ZP	P-ZP	P-ZP				\$11.5.8
	Manufacturing, Fabrication & Assembly -- General • <del>Vehicle: .3/ 1,000 s.f. GFA</del> • <del>Bicycle: No requirement</del>	L-ZP/ZPSE	L-ZP	L-ZP				\$11.5.9
	Manufacturing, Fabrication & Assembly -- Heavy • <del>Vehicle: .3/ 1,000 s.f. GFA</del> • <del>Bicycle: No requirement</del>	NP	L-ZP	L-ZP				\$11.5.10
Mining & Extraction and Energy Producing Systems	Oil, Gas -- Production, Drilling* • <del>Vehicle: .3/ 1,000 s.f. GFA</del> • <del>Bicycle: No requirement</del>	L-ZP	L-ZP	L-ZP				\$11.5.11
	Sand or Gravel Quarry* • <del>Vehicle: .3/ 1,000 s.f. GFA</del> • <del>Bicycle: No requirement</del>	NP	L-ZP	L-ZP				\$11.5.12
	Wind Energy Conversion Systems* • <del>No Parking Requirements</del>	L-ZP	L-ZP	L-ZP				\$11.5.13



**Modernizing Parking Requirements**  
**LUTI Committee Review Draft**  
**May 13, 2025**

Article 9. Special Contexts and Districts  
 Division 9.1 Industrial Context

KEY: \* = Need Not be Enclosed P = Permitted Use without Limitations L = Permitted Use with Limitations NP = Not Permitted Use  
 ZP = Zoning Permit Review ZPCIM = Subject to Zoning Permit Review with Community Information Meeting  
 ZPIN = Subject to Zoning Permit Review with Informational Notice ZPSE = Subject to Zoning Permit with Special Exception Review  
 When no ZP, ZPIN, ZPCIM, ZPSE listed = No Zoning Permit required

USE CATEGORY	SPECIFIC USETYPE <ul style="list-style-type: none"> <li>• <del>Vehicle Parking Requirement – # of spaces per unit of measurement</del></li> <li>• <del>Bicycle Parking Requirement – # of spaces per unit of measurement (% required spaces in indoor facility/% required spaces in fixed facility)</del></li> </ul>	I-MX-3	I-MX-5	I-MX-8	I-MX-12	I-A	I-B	APPLICABLE USE LIMITATIONS	
Transportation Facilities	Airport*					NP	NP	NP	
	Helipad, Heliport, Heliport* <ul style="list-style-type: none"> <li>• <del>Vehicle: .3/ 1,000 s.f. GFA</del></li> <li>• <del>Bicycle: No requirement</del></li> </ul>					L-ZP	L-ZP	L-ZP	§11.5.14
	Railroad Facilities* <ul style="list-style-type: none"> <li>• <del>Vehicle: .3/ 1,000 s.f. GFA</del></li> <li>• <del>Bicycle: No requirement</del></li> </ul>					L -ZP	L -ZP	L ZP	§11.5.14.1
	Railway Right-of-Way* <ul style="list-style-type: none"> <li>• <del>Vehicle: .3/ 1,000 s.f. GFA</del></li> <li>• <del>Bicycle: No requirement</del></li> </ul>					P-ZP	P-ZP	P-ZP	
	Terminal, Station or Service Facility for Passenger Transit System <ul style="list-style-type: none"> <li>• <del>Vehicle: .3/ 1,000 s.f. GFA</del></li> <li>• <del>Bicycle: No requirement</del></li> </ul>					P-ZP	P-ZP	P-ZP	
	Terminal, Freight, Air Courier Services <ul style="list-style-type: none"> <li>• <del>Vehicle: .3/ 1,000 s.f. GFA</del></li> <li>• <del>Bicycle: No requirement</del></li> </ul>					L-ZP	L-ZP	L-ZP	§11.5.17
Waste Related Services	Automobile Parts Recycling Business* <ul style="list-style-type: none"> <li>• <del>Vehicle: .3/ 1,000 s.f. GFA</del></li> <li>• <del>Bicycle: No requirement</del></li> </ul>					NP	L-ZP	L-ZP	§11.5.18
	Junkyard* <ul style="list-style-type: none"> <li>• <del>Vehicle: .3/ 1,000 s.f. GFA</del></li> <li>• <del>Bicycle: No requirement</del></li> </ul>					NP	NP	L-ZP	§11.5.19
	Recycling Center <ul style="list-style-type: none"> <li>• <del>Vehicle: .3/ 1,000 s.f. GFA</del></li> <li>• <del>Bicycle: No requirement</del></li> </ul>					L-ZPIN	L-ZP	L-ZP	§11.5.20
	Recycling Collection Station <ul style="list-style-type: none"> <li>• <del>Vehicle: .3/ 1,000 s.f. GFA</del></li> <li>• <del>Bicycle: No requirement</del></li> </ul>					P-ZP	P-ZP	P-ZP	
	Recycling Plant, Scrap Processor <ul style="list-style-type: none"> <li>• <del>Vehicle: .3/ 1,000 s.f. GFA</del></li> <li>• <del>Bicycle: No requirement</del></li> </ul>					L-ZP	L-ZP	L-ZP	§11.5.21
	Solid Waste Facility <ul style="list-style-type: none"> <li>• <del>Vehicle: .3/ 1,000 s.f. GFA</del></li> <li>• <del>Bicycle: No requirement</del></li> </ul>					NP	P-ZPIN	P-ZP	
Wholesale, Storage, Warehouse & Distribution	Automobile Towing Service Storage Yard* <ul style="list-style-type: none"> <li>• <del>Vehicle: .3/ 1,000 s.f. GFA</del></li> <li>• <del>Bicycle: No requirement</del></li> </ul>					NP	L-ZP	L-ZP	§11.5.22
	Mini-storage Facility <ul style="list-style-type: none"> <li>• <del>Vehicle: 0.1/ 1,000 s.f. GFA</del></li> <li>• <del>Bicycle: No requirement</del></li> </ul>					L-ZP	L-ZP	L-ZP	§11.5.23
	Vehicle Storage, Commercial* <ul style="list-style-type: none"> <li>• <del>Vehicle: .3/ 1,000 s.f. GFA</del></li> <li>• <del>Bicycle: No requirement</del></li> </ul>					NP	L-ZP	L-ZP	§11.5.24
	Wholesale Trade or Storage, General <ul style="list-style-type: none"> <li>• <del>Vehicle: .3/ 1,000 s.f. GFA</del></li> <li>• <del>Bicycle: No requirement</del></li> </ul>					NP	L-ZP	L-ZP	§11.5.25
	Wholesale Trade or Storage, Light <ul style="list-style-type: none"> <li>• <del>Vehicle: .3/ 1,000 s.f. GFA</del></li> <li>• <del>Bicycle: No requirement</del></li> </ul>					P-ZP	P-ZP	P-ZP	§11.5.26

KEY: \* = Need Not be Enclosed P = Permitted Use without Limitations L = Permitted Use with Limitations NP = Not Permitted Use  
 ZP = Zoning Permit Review ZPCIM = Subject to Zoning Permit Review with Community Information Meeting  
 ZPIN = Subject to Zoning Permit Review with Informational Notice ZPSE = Subject to Zoning Permit with Special Exception Review  
 When no ZP, ZPIN, ZPCIM, ZPSE listed = No Zoning Permit required

USE CATEGORY	SPECIFIC USE TYPE <ul style="list-style-type: none"> <li>• <del>Vehicle Parking Requirement - # of spaces per unit of measurement</del></li> <li>• <del>Bicycle Parking Requirement - # of spaces per unit of measurement (% required spaces in indoor facility/% required spaces in fixed facility)</del></li> </ul>	I-MX-3 I-MX-5 I-MX-8 I-MX-12	I-A	I-B	APPLICABLE USE LIMITATIONS
<b>AGRICULTURE PRIMARY USE CLASSIFICATION</b>					
Agriculture	Aquaculture* <ul style="list-style-type: none"> <li>• <del>Vehicle: .5 / 1,000 s.f. GFA</del></li> <li>• <del>Bicycle: No requirement</del></li> </ul>	L-ZP	L-ZP	L-ZP	§11.6.1
	Garden, Urban* <ul style="list-style-type: none"> <li>• <del>Vehicle: .5 / 1,000 s.f. GFA</del></li> <li>• <del>Bicycle: No requirement</del></li> </ul>	L-ZP	L-ZP	L-ZP	§11.6.2
	Husbandry, Animal* <ul style="list-style-type: none"> <li>• <del>Vehicle: .5 / 1,000 s.f. GFA</del></li> <li>• <del>Bicycle: No requirement</del></li> </ul>	NP	NP	L-ZP	§11.6.3
	Husbandry, Plant* <ul style="list-style-type: none"> <li>• <del>Vehicle: .5 / 1,000 s.f. GFA</del></li> <li>• <del>Bicycle: No requirement</del></li> </ul>	NP	L-ZP	L-ZP	§11.6.4
	Plant Nursery <ul style="list-style-type: none"> <li>• <del>Vehicle: .5 / 1,000 s.f. GFA</del></li> <li>• <del>Bicycle: No requirement</del></li> </ul>	L-ZP	L-ZP*	L-ZP*	§11.6.5
<b>ACCESSORY TO PRIMARY RESIDENTIAL USES USE CLASSIFICATION</b>					
Accessory to Primary Residential Uses  In the I-A and I-B Zone Districts, see Sections 11.2.1 through 11.2.3 for additional limitations on accessory uses.  ( <del>Parking is Not Required for Accessory Uses Unless Specifically Stated in this Table or in an Applicable Use Limitation</del> )	Unlisted Accessory Uses	L - Applicable in all Zone Districts			§11.7
	Accessory Dwelling Unit	L-ZP	NP	NP	§11.7; §11.8.2
	Domestic Employee	L	NP	NP	§11.8.3
	Garden*	L	L	L	§11.7; §11.8.4
	Keeping of Household Animals*	L / L-ZPIN	L / L-ZPIN	L / L-ZPIN	§11.7; §11.8.5
	Keeping and Off-Street Parking of Vehicles, Motorcycles, Trailers & Recreational Vehicles*	L	NP	NP	§11.7; §10.9
	Kennel or Exercise Run*	L	L	L	§11.7; §11.8.6
	Limited Commercial Sales, Services Accessory to Multi-Unit Dwelling Use	Not Applicable - See Permitted Primary Uses	NP	NP	§11.7; §11.8.7
	Outdoor Storage, Residential*	L	L	L	§11.7; §11.8.8
	Second Kitchen Accessory to Single Unit Dwelling Use	L-ZP	L-ZP	L-ZP	§11.8.9
	Short-term Rental	L	L	L	§11.7; §11.8.10
	Vehicle Storage, Repair and Maintenance*	L	L	L	§11.7; §10.9
	Wind Energy Conversion Systems*	Not Applicable - See Permitted Primary Uses			
Yard or Garage Sales*	L	L	L	§11.7; §11.8.11	

KEY: \* = Need Not be Enclosed P = Permitted Use without Limitations L = Permitted Use with Limitations NP = Not Permitted Use  
ZP = Zoning Permit Review ZPCIM = Subject to Zoning Permit Review with Community Information Meeting  
ZPIN = Subject to Zoning Permit Review with Informational Notice ZPSE = Subject to Zoning Permit with Special Exception Review  
When no ZP, ZPIN, ZPCIM, ZPSE listed = No Zoning Permit required

USE CATEGORY	SPECIFIC USE TYPE • Vehicle Parking Requirement - # of spaces per unit of measurement • Bicycle Parking Requirement - # of spaces per unit of measurement (% required spaces in indoor facility/% required spaces in fixed facility)	I-MX-3 I-MX-5 I-MX-8 I-MX-12	I-A	I-B	APPLICABLE USE LIMITATIONS
<b>HOME OCCUPATIONS ACCESSORY TO PRIMARY RESIDENTIAL USES USE CLASSIFICATION</b>					
Home Occupations	Child Care Home, Large	L-ZP	L-ZP	L-ZP	§11.9; §11.9.3
	All Other Types	L-ZP	L-ZP	L-ZP	§11.9; §11.9.4
	Unlisted Home Occupations	L - ZPIN - Applicable in all Zone Districts			§11.9; §11.9.5
<b>ACCESSORY TO PRIMARY NONRESIDENTIAL USES USE CLASSIFICATION</b>					
Accessory to Primary Nonresidential Uses  (Parking is Not Required for Accessory Uses Unless Specifically Stated in this Table or in an Applicable Use Limitation)	Unlisted Accessory Uses	L - Applicable in all Zone Districts			§11.7; §11.10.1
	Amusement Devices Accessory to Eating/Drinking Establishments, College/University and Theater Uses	L-ZP	L-ZP	L-ZP	§11.7; §11.10.2
	Automobile Rental Services Accessory to Certain Retail Uses*	Not Applicable - See Permitted Primary Uses			§11.7; §11.10.3
	Book or gift store; media recording and production facilities accessory to public libraries, museums, places of religious assembly, colleges or universities	Not Applicable - See Permitted Primary Uses	L	L	§11.7
	Car Wash Bay Accessory to Automobile Services	L-ZP	L-ZP	L-ZP	§11.7; §11.10.5
	College Accessory to a Place for Religious Assembly	Not Applicable - See Permitted Primary Uses			§11.7; §11.10.6
	Conference Facilities Accessory to Hotel Use	L	L	L	§11.7; §11.10.7
	Drive Through Facility Accessory to Eating/Drinking Establishments and to Retail Sales, Service, and Repair Uses*	L-ZP	L-ZP	L-ZP	§11.7; §11.10.8
	Emergency Vehicle Access Point	NP	NP	NP	
	Garden*	L	L	L	§11.7; §11.10.10
	Keeping of Animals	L/L-ZP/ L-ZPIN	L/L-ZP/ L-ZPIN	L/L-ZP/ L-ZPIN	§11.7; § 11.10.11
	Limited Commercial Sales, Services	L	L	L	§11.7; §11.10.12
	Nonresidential Uses in Existing Business Structures In Residential Zones - Accessory Uses	Not Applicable			
	Occasional Sales, Services Accessory to Primary Places of Religious Assembly or Primary Uses Operated by Nonprofit Organizations*	L	L	L	§11.7; §11.10.13
	Outdoor Gathering Area*	L/L-ZP/ L-ZPIN	L/L-ZP/ L-ZPIN	L/L-ZP/ L-ZPIN	§11.7; §11.10.14
	Outdoor Entertainment Accessory to an Eating/Drinking Establishment Use*	L-ZPIN/ ZPSE	L-ZPIN/ ZPSE	L-ZPIN/ ZPSE	§11.7; §11.10.15
	Outdoor Retail Sale and Display*	L-ZP/ZPSE	L-ZP/ZPSE	L-ZP/ZPSE	§11.7; §11.10.16
	Outdoor Storage, General*	L-ZP	L-ZP	L-ZP	§11.7; §11.10.17
	Outdoor Storage, Limited*	L-ZP	P-ZP	P-ZP	§11.7; §11.10.18
	Rental or Sales of Adult Material Accessory to a Permitted Bookstore Use	L	NP	NP	§11.7; §11.10.19
Retail Food Establishment, Mobile (Food Truck)*	L-ZP	L-ZP	L-ZP	§11.7; §11.10.20	

KEY: \* = Need Not be Enclosed P = Permitted Use without Limitations L = Permitted Use with Limitations NP = Not Permitted Use  
 ZP = Zoning Permit Review ZPCIM = Subject to Zoning Permit Review with Community Information Meeting  
 ZPIN = Subject to Zoning Permit Review with Informational Notice ZPSE = Subject to Zoning Permit with Special Exception Review  
 When no ZP, ZPIN, ZPCIM, ZPSE listed = No Zoning Permit required

USE CATEGORY	SPECIFIC USE TYPE <ul style="list-style-type: none"> <li>• <del>Vehicle Parking Requirement - # of spaces per unit of measurement</del></li> <li>• <del>Bicycle Parking Requirement - # of spaces per unit of measurement (% required spaces in indoor facility/% required spaces in fixed facility)</del></li> </ul>	I-MX-3 I-MX-5 I-MX-8 I-MX-12	I-A	I-B	APPLICABLE USE LIMITATIONS
<b>TEMPORARY USE CLASSIFICATION</b>					
Temporary Uses	Unlisted Temporary Uses	L - Applicable to all Zone Districts			§11.11.1
	Ambulance Service - Temporary	Not Applicable - See Permitted Primary Uses			§11.11.2
	Amusement / Entertainment - Temporary*	L-ZP	L-ZP	L-ZP	§11.11.3
	Bazaar, Carnival, Circus or Special Event*	L-ZP	L-ZP	L-ZP	§11.11.4
	Building or yard for construction materials*	L-ZP	L-ZP	L-ZP	§11.11.5
	Concrete, Asphalt, and Rock Crushing Facility*	L-ZP	L-ZP	L-ZP	§11.11.6
	Fence for Demolition or Construction Work	L-ZP	L-ZP	L-ZP	§11.11.7
	Health Care Center	P-ZP	P-ZP	P-ZP	
	Noncommercial Concrete Batching Plant*	L-ZP	L-ZP	L-ZP	§11.11.9
	Outdoor Retail Sales - Pedestrian / Transit Mall*	NP	NP	NP	
	Outdoor Retail Sales*	L-ZP	L-ZP	L-ZP	§11.11.11
	Outdoor Sales, Seasonal*	L-ZP	L-ZP	L-ZP	§11.11.12
	Parking Lot Designated for a Special Event*	L-ZP	L-ZP	L-ZP	§11.11.13
	Retail Food Establishment, Mobile (Food Truck)*	L/L-ZP	L/L-ZP	L/L-ZP	§11.11.14
	Temporary Construction Office	L-ZP	L-ZP	L-ZP	§11.11.15
	Temporary Office - Real Estate Sales	L-ZP	NP	NP	§11.11.16
	Temporary Managed Community*	L-ZPCIM	L-ZPCIM	L-ZPCIM	§11.11.17
	Tent for Religious Services	L-ZP	L-ZP	L-ZP	§11.11.18

## GENERAL (1 OF 2)

### HEIGHT

	CMP-H
A Feet, (max)	200'
A Feet, within 125' of Protected District (max)	75'

### SITING

#### SETBACKS

	CMP-H
B Primary Street (min)	10'
C Side Street (min)	7.5'
D Side Interior (min)	7.5'
Side Interior, adjacent to Protected District (min)	10'
E Rear, where Alley (public or private) abuts a Rear Zone Lot Line (min)	10'
E Rear, where Alley (public or private) does not abut a Rear Zone Lot Line (min)	20'

#### PARKING

Vehicle Access, 3 or more side-by-side dwelling units in one structure	From Alley; or Street access allowed when no Alley present (Sec. 9.2.7.43)
Vehicle Access, all other permitted uses	Access determined as part of Site Development Plan Review

### DESIGN ELEMENTS

	CMP-H
F Upper Story Setback Above 40'; Side Interior (min)*	15'
G Upper Story Setback Above 65', Rear, alley/rear, no alley and side interior (min)*	20'/30'
H Upper Story Setback Above 27' adjacent to Protected District, Side Interior (min)	25'
H Upper Story Setback Above 40' adjacent to Protected District, Rear, alley/ Rear, no alley (min)	30'/40'
I Upper Story Setback Above 51' adjacent to Protected District, Side Interior (min)	40'

### USES

All permitted Uses shall be allowed within this building form. See Section 9.2.8, Uses and Parking

\* When CMP-H and CMP-H2 are abutting, the bulk plane and upper story setback required along that shared zone district boundary are not applicable

## GENERAL (2 OF 2)

### HEIGHT

#### CMP-H2

A	Feet, (max)	140'
A	Feet, within 125' of Protected District (max)	75'
B	Bulk Plane Vertical Height at Centerline of Primary Street*	10'
C	Bulk Plane Vertical Height at Centerline of Side Street*	10'
D	Bulk Plane Vertical Height at Side Interior Property Line*	10'
E	Bulk Plane Vertical Height at Rear Property Line, or Centerline of alley if present	10'
	Bulk Plane Slope*	45°

### SITING

#### CMP-H2

#### SETBACKS AND BUILDING COVERAGE

F	Primary Street (min)	20'
G	Side Street (min)	7.5
H	Side Interior (min)	7.5'
I	Rear, where Alley (public or private) abuts a Rear Zone Lot Line (min)	10'
I	Rear, where Alley (public or private) does not abut a Rear Zone Lot Line (min)	20'
	Building Coverage, including all accessory structures (max)	60%

#### PARKING

Vehicle Access, 3 or more side-by-side dwelling units in one structure	From Alley; or Street access allowed when no Alley present (Sec. 9.2.7.43)
Vehicle Access, all other permitted uses	Access determined as part of Site Development Plan Review

### USES

#### CMP-H2

All permitted Uses shall be allowed within this building form. See Section 9.2.8, [Uses, and Parking](#)

\*When CMP-H and CMP-H2 are abutting, the bulk plane and upper story setback required along that shared zone district boundary are not applicable.

## GENERAL (1 OF 2)

### HEIGHT

	CMP-EI
A Feet, (max)	150'
A Feet, within 175' of Protected District (max)	75'

### SITING

#### SETBACKS

	CMP-EI
B Primary Street (min)	10' 0' abutting Speer Boulevard, Auraria Parkway, or 5th Street or 7th Street between Auraria and Colfax
C Side Street (min)	7.5'
D Side Interior (min)	7.5'
	Side Interior, adjacent to Protected District (min)
	10'
E Rear, where Alley (public or private) abuts a Rear Zone Lot Line (min)	10'
E Rear, where Alley (public or private) does not abut a Rear Zone Lot Line (min)	20'

#### PARKING

Vehicle Access, 3 or more side-by-side dwelling units in one structure	From Alley; or Street access allowed when no Alley present (Sec. 9.2.7.43)
Vehicle Access, all other permitted uses	Access determined as part of Site Development Plan Review

### DESIGN ELEMENTS

	CMP-EI
F Upper Story Setback Above 40', Side Interior (min)	15'
G Upper Story Setback Above 65', Rear, alley/rear, no alley and side interior (min)	20'/30'
H Upper Story Setback Above 27' adjacent to Protected District, Side Interior (min)	25'
H Upper Story Setback Above 40' adjacent to Protected District, Rear, alley/ Rear, no alley (min)	30'/40'
I Upper Story Setback Above 51' adjacent to Protected District, Side Interior (min)	40'

### USES

CMP-EI  
All permitted Uses shall be allowed within this building form. See Section 9.2.8, [Uses, and Parking](#)

## GENERAL (2 OF 2)

<b>HEIGHT</b>		<b>CMP-EI2</b>
A	Feet (max)	150'
A	Feet, within 175' of Protected District (max)	75'
B	Bulk Plane Vertical Height at Centerline of Primary Street	10'
C	Bulk Plane Vertical Height at Centerline of Side Street	10'
D	Bulk Plane Vertical Height at Side Interior Property Line	10'
E	Bulk Plane Vertical Height at Rear Property Line, or Centerline of alley if present	10'
	Bulk Plane Slope	45°

<b>SITING</b>		<b>CMP-EI2</b>
<b>SETBACKS AND BUILDING COVERAGE</b>		
F	Primary Street (min)	20'
G	Side Street (min)	7.5'
H	Side interior (min)	7.5'
I	Rear, where Alley (public or private) abuts a Rear Zone Lot Line (min)	10'
I	Rear, where Alley (public or private) does not abut a Rear Zone Lot Line (min)	20'
	Building Coverage, including all accessory structures (max)	60%

<b>PARKING</b>		
	Vehicle Access, 3 or more side-by-side dwelling units in one structure	From Alley; or Street access allowed when no Alley present (Sec. 9.2.7.43)
	Vehicle Access, all other permitted uses	Access determined as part of Site Development Plan Review

<b>USES</b>		<b>CMP-EI2</b>
		All permitted Uses shall be allowed within this building form. See Section 9.2.8, Uses, and Parking



## GENERAL

<b>HEIGHT</b>		<b>CMP-ENT</b>
A	Feet (max)	200'
A	Feet, within 175' of Protected District (max)	75'

<b>SITING</b>		<b>CMP-ENT</b>
<b>SETBACKS</b>		
B	Primary Street (min)	10'
C	Side Street (min)	7.5'
D	Side Interior (min)	7.5'
D	Side Interior, adjacent to Protected District (min)	10'
E	Rear, where Alley (public or private) abuts a Rear Zone Lot Line (min)	10'
	Rear, where Alley (public or private) does not abut a Rear Zone Lot Line (min)	20'

<b>PARKING</b>		<b>CMP-ENT</b>
	Vehicle Access, 3 or more side-by-side dwelling units in one structure,	From Alley; or Street access allowed when no Alley present (Sec. 9.2.7.43)
	Vehicle Access, all other permitted uses	Access determined as part of Site Development Plan Review

<b>DESIGN ELEMENTS</b>		<b>CMP-ENT</b>
F	Upper Story Setback Above 40', Side Interior (min)	15'
G	Upper Story Setback Above 65', Rear, alley/rear, no alley and side interior (min)	20'/30'
H	Upper Story Setback Above 27' adjacent to Protected District, Side Interior (min)	25'
	Upper Story Setback Above 40' adjacent to Protected District, Rear, alley/Rear, no alley (min)	30'/40'
I	Upper Story Setback Above 51' adjacent to Protected District, Side Interior (min)	40'

<b>USES</b>		<b>CMP-ENT</b>
		All permitted Uses shall be allowed within this building form. See Section 9.2.8, <u>Uses</u> , and <u>Parking</u>

## GENERAL (CONT'D)

DESIGN ELEMENTS					
	CMP-NWC	CMP-NWC-C	CMP-NWC-G	CMP-NWC-F	CMP-NWC-R
<b>STREET LEVEL ACTIVATION</b>					
Transparency, Primary Street (min)	na	60%	10%	na	40%
Transparency, South Platte River Primary Street (min)	na	60%	10%	40%	40%
Transparency, Side Street (min)	na	35%	na	na	na
Pedestrian Access, Primary Street	na	Entrance	Entrance	Pedestrian Connection	Entrance
Pedestrian Access, Side Street	na	Entrance	na	na	na

USES					
	CMP-NWC	CMP-NWC-C	CMP-NWC-G	CMP-NWC-F	CMP-NWC-R
Street Level Active Uses (minimum percentage of Primary Street building frontage meeting build-to requirement, see Section 9.2.6.5.B)	na	100%	20%	na	na
Permitted Primary Uses	All permitted uses shall be allowed within this building form. See Section 9.2.8, <del>Uses</del> <b>and Parking</b>				

See Sections 9.2.6.5 -9.2.6.6 for Supplemental Design Standards and Design Standard Alternatives. See Sections 9.2.6.7 and 9.2.7 for Design Standard Exceptions.

BUILDING FEATURES	ZONE DISTRICTS	THE AGGREGATE SHALL NOT EXCEED 33-1/3 PERCENT OF THE AREA OF THE SUPPORTING ROOF	SHALL BE SET BACK FROM THE PERIMETER OF THE BUILDING A MINIMUM OF ONE FOOT HORIZONTALLY FOR EVERY ONE FOOT OF VERTICAL HEIGHT	MAY EXCEED MAXIMUM HEIGHT IN FEET BY:	MAY EXCEED MAXIMUM HEIGHT IN STORIES BY:	MAY PROJECT THROUGH THE BULK PLANE	MAY EXCEED UPPER STORY SETBACK HEIGHT BY
Unoccupied elevator penthouses, stair enclosures, and enclosed or unenclosed mechanical equipment including vertical or sloped screen walls for such equipment	All CMP- Zone Districts	Yes	Yes, from the perimeter of the portion of the building facing the Primary Street or Side Street.  Yes, from the perimeter of the portion of the building facing the zone lot line adjacent to a Protected District.  No, all others.	28'	1 story	Not allowed	Not allowed
Elevator lobbies	All CMP- Zone Districts	Yes	Yes	28'	1 story	Not allowed	Not allowed
Open Structures	All CMP- Zone Districts	Yes	Yes	28'	Not applicable	Not allowed	Not allowed
Parapet Wall or Safety Railing	All CMP- Zone Districts	No	No	Any distance	Not applicable	Not allowed	4'
Solar panels	All CMP- Zone Districts	No	No	Any distance	Not applicable	Any distance	Any distance
Evaporative coolers	All CMP- Zone Districts	No	Yes	Any distance	Not applicable	Any distance	Any distance
Accessory water tanks	All CMP- Zone Districts	No	Yes	28'	Not applicable	Any distance	Any distance
Pedestrian bridge	All CMP- Zone Districts	Not applicable	Not applicable	28'	Any number	Any distance	Any distance

### 9.2.7.2 Setback Exceptions - Architectural, Site, Service & Utility Elements

#### A. Intent

To allow minor elements to encroach into a setback while maintaining an open and unobstructed minimum setback.

#### B. Standard

Except as specifically allowed below, Setbacks specified in the applicable Building Form tables shall be open and unobstructed.

#### C. Exceptions

The following Structures or portions of Structures are permitted to encroach into the Setbacks subject to the limitations in the tables below. No portion of a Structure that encroaches into the Setbacks shall extend into a required Setback beyond the maximum Setback encroachment distance specified in the tables below, as measured perpendicular to the respective Zone Lot line. Where more than one Setback encroachment is allowed for the same Structure or portion of a Structure, the permitted Setback encroachment distances shall not be cumulative. See "Height Exceptions" for encroachments related to Upper Story Setbacks.

##### 1. Architectural Elements

To allow for minor elements which add to the architectural character of buildings, while maintaining an open and unobstructed setback.

	ZONE DISTRICTS	BUILDING FORMS	PRIMARY STREET	SIDE STREET	SIDE INTERIOR	REAR
Fences and Walls	See Division 10.5 Landscaping, Fences, Walls and Screening					
	ZONE DISTRICTS	BUILDING FORMS	PRIMARY STREET	SIDE STREET	SIDE INTERIOR	REAR
Surface Parking	All CMP- Zone Districts	All Building Forms	Not allowed	Not allowed	Not allowed	Any distance
Intent: To restrict surface parking where it is <u>more</u> impactful <del>due to the number of required parking spaces.</del>	<p style="text-align: right;"><i>Not to Scale. Illustrative Only.</i></p>					

### 9.2.7.3 Vehicle Access From Alley Required - Exceptions

#### A. No Alley

Where a building form specifies “street access allowed when no Alley present”, vehicle access from the street is allowed when a Zone Lot is not bounded by an Alley.

#### B. Alley Access Required

Where a building form specifies vehicle access from Alley is required, and the Zone Lot is bounded by an Alley, any newly constructed Driveway, Off-Street Parking Area, Garage, Carport, or other parking facility shall be accessed solely from an Alley, unless the applicant can demonstrate at the time of zoning permit application that an exception stated in this Section 9.2.7.43 applies.

#### C. DOTI Approval Required for All Exceptions to Alley Access

The Department of Transportation and Infrastructure (“DOTI”) shall approve all requests for an exception to required Alley access under this Section 9.2.7.43.

#### D. General Exceptions

When one or more of the conditions listed in this Section 9.2.7.43.D apply, street access may be used instead of alley access. However, if improvements to any portion of the Alley, including widening and/or repaving, are required by the City at the time of Development due to a change in use or intensity, which improvements resolve one or more conditions for an exception specified in this Section 9.2.7.43.D, then vehicular Alley access shall be required.

1. The Alley is not provided with an all-weather surface of asphalt, asphaltic concrete, concrete, or any equivalent material;
2. The Alley is less than 12 feet in width;
3. At least 60 percent of the existing Zone Lots on the same Face Block are served by Driveways, Off-Street Parking Areas, Garages, Carports, or other parking facilities accessed from a primary street.
4. The Department of Transportation and Infrastructure (“DOTI”) prohibits the use of the Alley for vehicular access to the Zone Lot based upon a determination that the Alley cannot safely or operationally accommodate additional vehicular traffic; or
5. The Primary Use is within the Civic, Public, and Institutional Use Category and the DRC determines during Site Development Plan review that street access is more consistent with the Comprehensive Plan, or is necessary to ensure safety or vehicle operational needs.

#### E. Special Exception for Pre-Existing Street Access

When the conditions listed in this Section 9.2.7.43.E apply, street access may be used instead of alley access.

1. Vehicular access from the street to an accessory Garage, Carport, or other Off-Street Parking Area was legally established, constructed, or expanded prior to June 25, 2010, and has been Continuously Maintained; and
2. The Primary Structure containing either a Single-Unit or Two-Unit Dwelling use on the same Zone Lot is not Voluntarily Demolished. In the case of Voluntary Demolition of the Primary Structure, vehicle access must be taken from the Alley unless otherwise allowed by this Section 9.2.7.43.E.

## SECTION 9.2.8 USES ~~AND REQUIRED MINIMUM PARKING~~

### 9.2.8.1 Applicability

- A. This Section 9.2.8 sets forth the land uses permitted; ~~and the~~ required zoning procedures ~~and the required minimum parking~~ for all the Campus Context zone districts.
- B. Uses not listed are prohibited, unless the Zoning Administrator specifically permits the unlisted use according to Section 12.4.6, Code Interpretations and Determination of Unlisted Uses.
- C. For number of primary and accessory uses allowed per Zone Lot, see Section 1.2.3.5, Number of Structures and Uses Allowed per Zone Lot.

### 9.2.8.2 Organization

#### A. Organized by Primary, Accessory and Temporary Uses

The Use ~~and Parking~~ Table first presents all primary uses, then all accessory uses, and finally all temporary uses. Primary uses are arranged hierarchically within the table by use classification, category of primary uses, and then by specific use type. Accessory uses are organized by whether such use is accessory to a primary residential use or to a primary nonresidential use. Temporary uses are presented alphabetically ordered in the last division of the table.

#### B. Primary Use Classifications, Categories & Specific Use Types

##### 1. Primary Use Classifications

All primary land uses in the Use ~~and Parking~~ Table are organized into one of the following five general land use classifications:

- a. Residential Uses
- b. Civic, Public & Institutional Uses
- c. Commercial Sales, Service & Repair Uses
- d. Industrial, Manufacturing & Wholesale Uses
- e. Agriculture

##### 2. Primary Use Categories & Specific Use Types

Primary uses are further organized into use categories and specific use types listed under each general primary land use classification. The Use ~~and Parking~~ Table is organized into the above five general land use classifications, use categories and specific use types.

##### 3. Classifications & Categories Are Mutually Exclusive

The general land use classifications and use categories listed in the Use ~~and Parking~~ Table are intended to be mutually exclusive; that is, a use classified into one use category, such as “lodging accommodations,” cannot be classified in a different use category, such as “congregate living” unless otherwise expressly allowed by this Code.

### 9.2.8.3 Explanation of Table Abbreviations

#### A. General Explanation of Table Cell Entries

In each of the table cells, the entry will indicate first whether use limitations apply to the specific use, and then separated by a hyphen, the type of zoning review required prior to establishment of the use under this Code. For example, as described in more detail below, a cell entry “L-ZPIN” means, first, the use is subject to use limitations (the “L”), and, second, that the use is subject to zoning permit review with information notice (the “ZPIN”) prior to its establishment.

#### B. Permitted, Limited, Not Permitted

##### 1. Permitted Use - No Use Limitations Apply (“P”)

A “P” in a table cell indicates that the use is permitted in the respective zone district, and is not subject to use limitations.

**2. Permitted Use - Subject to Use Limitations (“L”)**

“L” in a table cell indicates the use is permitted in the zone district subject to compliance with the use limitations referenced in the last column of the use table (“Applicable Use Limitations”).

**3. Uses Not Permitted (“NP”)**

“NP” in a table cell indicates that the use is not permitted in the specific zone district.

**C. Zoning Procedure**

**1. Use Subject to Zoning Permit Review (“ZP”)**

“ZP” in a table cell indicates that the use is permitted in the respective zone district only if reviewed and approved according to the requirements in Section 12.4.1, Zoning Permit Review.

**2. Use Subject to Zoning Permit Review with Informational Notice (“ZPIN”)**

“ZPIN” in a table cell indicates that the use is permitted in the respective zone district only if reviewed and approved according to the public notice and procedural requirements in Section 12.4.2, Zoning Permit Review with Informational Notice. Such uses shall comply with any applicable use limitations noted in the last column of the use table (“Applicable Use Limitations”), as well as the review criteria stated in Section 12.4.2, Zoning Permit Review with Informational Notice.

**3. Use Subject to Zoning Permit Review with Community Information Meeting (“ZPCIM”)**

“ZPCIM” in a table cell indicates that the use is permitted in the respective zone district only if reviewed and approved according to the public notice and procedural requirements in Section 12.4.1, Zoning Permit Review. Prior to formal application, an applicant shall schedule a community information meeting and provide public notice of the community information meeting according to Section 12.3.4.6, Community Information Meeting.

**4. Use Subject to Zoning Permit with Special Exception Review (“ZPSE”)**

“ZPSE” in a table cell indicates that use is generally appropriate in the neighborhood context and zone district, yet may have the potential for limited impacts on adjacent properties or on the established character of the neighborhood context or zone district. “ZPSE” uses are subject to a Board of Adjustments public hearing according to Section 12.4.9, Zoning Permit with Special Exception Review, which grants the Board of Adjustment the authority to impose conditions on the specified use to mitigate any potential impacts. Such uses shall comply with any applicable use limitations noted in the last column of the use table (“Applicable Use Limitations”), as well as the review criteria stated in Section 12.4.9, Zoning Permit with Special Exception Review.

**5. Uses Where More Than One Zoning Procedure Is Indicated**

Where a table cell shows more than one zoning procedure applies to a use, for example “L-ZP/ZPIN”, the referenced use limitation (last table column) will indicate which zoning procedure applies in a specific case. For example, a table cell may indicate “L-ZPIN/ZPSE” for a use. This means that the ZPIN zoning procedure will apply, unless the applicable use limitation specifies the ZPSE zoning procedure is triggered (e.g., by proximity to a Protected District).

**9.2.8.4 Enclosure of Uses**

All primary, accessory and temporary uses must be established, operated and maintained within a Completely Enclosed Structure, unless otherwise specifically allowed by this Code. The Use ~~and~~ **Parking** Tables in Articles 3-9 indicate when a use may be established, operated or maintained outside a Completely Enclosed Structure by including an asterisk “\*” next to the specific use type. For example, the asterisk following the “Telecommunication Tower\*” use type in the tables indicates that a telecommunication tower land use need not be enclosed.

### 9.2.8.5 District Specific Standards

KEY: \* = Need Not be Enclosed P = Permitted Use without Limitations L = Permitted Use with Limitations NP = Not Permitted Use ZP = Zoning Permit Review  
ZPCIM = Subject to Zoning Permit Review with Community Information Meeting ZPIN = Subject to Zoning Permit Review with Informational Notice  
ZPSE = Subject to Zoning Permit with Special Exception Review When no ZP, ZPCIM, ZPIN, ZPSE listed = No Zoning Permit required

USE CATEGORY	SPECIFIC USE TYPE <i>• Vehicle Parking Requirement – # of spaces per unit of measurement</i> <i>• Bicycle Parking Requirement – # of spaces per unit of measurement (% required spaces in indoor facility/% required spaces in fixed facility)</i>	RESIDENTIAL PRIMARY USE CLASSIFICATION								APPLICABLE USE LIMITATIONS
		CMP-H CMP-H2	CMP-EI CMP-EI2	CMP-ENT	CMP-NWC	CMP-NWC-C	CMP-NWC-G	CMP-NWC-F	CMP-NWC-R	
Household Living	Dwelling, Single Unit <i>• No Parking Requirements</i>	NP	L-ZP	NP	L-ZP	L-ZP	L-ZP	L-ZP	NP	\$11.2.7
	Dwelling, Two Unit <i>• Vehicle: 0.75/unit</i> <i>• CMP-NWC-C, CMP-NWC-G, CMP-NWC-F, CMP-NWC-R Districts – Vehicle: No requirement</i> <i>• Bicycle: No requirement</i>	NP	L-ZP	NP	L-ZP	L-ZP	L-ZP	L-ZP	NP	\$11.2.7
	Dwelling, Multi-Unit <i>• Vehicle: 0.75/unit</i> <i>• CMP-NWC-C, CMP-NWC-G, CMP-NWC-F, CMP-NWC-R Districts – Vehicle: No requirement</i> <i>• Bicycle: 1/2 units (80/20)</i>	L-ZPIN	EI: L-ZP EI2: L-ZPIN	L-ZP	L-ZP	L-ZP	L-ZP	L-ZP	NP	\$11.2.7
	Dwelling, Live / Work <i>• Vehicle: 0.75/unit</i> <i>• CMP-NWC-C, CMP-NWC-G, CMP-NWC-F, CMP-NWC-R Districts – Vehicle: No requirement</i> <i>• Bicycle: 1/2 units (80/20)</i>	NP	NP	NP	P-ZP	P-ZP	P-ZP	P-ZP	NP	
	Manufactured Home Community	NP	NP	NP	NP	NP	NP	NP	NP	
Residential Care	Residential Care, Type 1 <i>• Vehicle: .5/1,000 sf GFA</i> <i>• Bicycle: No requirement</i>	L/L-ZP	L/L-ZP	L/L-ZP	L/L-ZP	L/L-ZP	L/L-ZP	L/L-ZP	L/L-ZP	\$11.2.7; §11.2.8
	Residential Care, Type 2 <i>• Vehicle: .5/1,000 sf GFA</i> <i>• Bicycle: No requirement</i>	L-ZP	L-ZP	L-ZP	L-ZP	L-ZP	L-ZP	L-ZP	L-ZP	\$11.2.7; §11.2.9
	Residential Care, Type 3 <i>• Vehicle: .5/1,000 sf GFA</i> <i>• Bicycle: No requirement</i>	L-ZPCIM	L-ZPCIM	L-ZPCIM	L-ZPCIM	L-ZPCIM	L-ZPCIM	L-ZPCIM	L-ZPCIM	\$11.2.7; §11.2.10
	Residential Care, Type 4 <i>• Vehicle: .5/1,000 sf GFA</i> <i>• Bicycle: No requirement</i>	L-ZPCIM	L-ZPCIM	L-ZPCIM	L-ZPCIM	L-ZPCIM	L-ZPCIM	L-ZPCIM	L-ZPCIM	\$11.2.7; §11.2.11
Congregate Living	All Types <i>• Vehicle: 1/1,000 sf GFA</i> <i>• Bicycle: 1/20,000 sf GFA</i>	P-ZP	P-ZP	P-ZP	P-ZP	P-ZP	P-ZP	P-ZP	P-ZP	



KEY: \* = Need Not be Enclosed P = Permitted Use without Limitations L = Permitted Use with Limitations NP = Not Permitted Use ZP = Zoning Permit Review ZPCIM = Subject to Zoning Permit Review with Community Information Meeting ZPIN = Subject to Zoning Permit Review with Informational Notice ZPSE = Subject to Zoning Permit with Special Exception Review When no ZP, ZPCIM, ZPIN, ZPSE listed = No Zoning Permit required

USE CATEGORY	SPECIFIC USE TYPE <i>• Vehicle Parking Requirement – # of spaces per unit of measurement • Bicycle Parking Requirement – # of spaces per unit of measurement (% required spaces in indoor facility/% required spaces in fixed facility)</i>	APPLICABLE USE LIMITATIONS								
		CMP-H CMP-H2	CMP-EI CMP-EI2	CMP-ENT	CMP-NWC	CMP-NWC-C	CMP-NWC-G	CMP-NWC-F	CMP-NWC-R	
<b>CIVIC, PUBLIC &amp; INSTITUTIONAL PRIMARY USE CLASSIFICATION</b>										
Basic Utilities	Utility, Major Impact* <i>• Vehicle: -5/1,000 s.f. GFA • CMP-NWC-C, CMP-NWC-G, CMP-NWC-F, CMP-NWC-R Districts – Vehicle: No requirement • Bicycle: No requirement</i>	L-ZPSE	L-ZPSE	L-ZPSE	L-ZPSE	L-ZPSE	L-ZPSE	L-ZPSE	L-ZPSE	§ 11.3.1
	Utility, Minor Impact* <i>• Vehicle: -5/1,000 s.f. GFA • CMP-NWC-C, CMP-NWC-G, CMP-NWC-F, CMP-NWC-R Districts – Vehicle: No requirement • Bicycle: No requirement</i>	L-ZP	L-ZP	L-ZP	L-ZP	L-ZP	L-ZP	L-ZP	L-ZP	§ 11.3.2
Community/ Public Services	Community Center* <i>• Vehicle: No requirement • Bicycle: 1/10,000 s.f. GFA (0/100)</i>	L-ZP	L-ZP	P-ZP	P-ZP	P-ZP	P-ZP	P-ZP	P-ZP	§ 11.3.3
	Day Care Center <i>• Vehicle: 1/1,000 s.f. GFA • CMP-NWC-C, CMP-NWC-G, CMP-NWC-F, CMP-NWC-R Districts – Vehicle: No requirement • Bicycle: 1/10,000 s.f. GFA (0/100)</i>	P-ZP	P-ZP	P-ZP	P-ZP	P-ZP	P-ZP	P-ZP	P-ZP	
	Postal Facility, Neighborhood <i>• Vehicle: 1.25/1,000 s.f. GFA • CMP-NWC-C, CMP-NWC-G, CMP-NWC-F, CMP-NWC-R Districts – Vehicle: No requirement • Bicycle: 1/7,500 s.f. GFA (20/80)</i>	NP	NP	NP	P-ZP	P-ZP	P-ZP	P-ZP	NP	
	Postal Processing Center	NP	NP	NP	NP	NP	NP	NP	NP	
	Public Safety Facility <i>• Vehicle: 1/1,000 s.f. GFA • CMP-NWC-C, CMP-NWC-G, CMP-NWC-F, CMP-NWC-R Districts – Vehicle: No requirement • Bicycle: 1/10,000 s.f. GFA (0/100)</i>	P-ZP	P-ZP	P-ZP	P-ZP	P-ZP	P-ZP	P-ZP	P-ZP	
	Hospital Correctional Institution	P-ZP NP	NP NP	NP NP	NP NP	NP NP	NP NP	NP NP	NP NP	
Cultural/ Special Purpose/ Public Parks & Open Space	Cemetery*	NP	NP	NP	NP	NP	NP	NP	NP	
	Library <i>• Vehicle: 1/1,000 s.f. GFA • CMP-NWC-C, CMP-NWC-G, CMP-NWC-F, CMP-NWC-R Districts – Vehicle: No requirement • Bicycle: 1/10,000 s.f. GFA (0/100)</i>	NP	P-ZP	P-ZP	P-ZP	P-ZP	P-ZP	P-ZP	P-ZP	
	Museum <i>• Vehicle: 1/1,000 s.f. GFA • CMP-NWC-C, CMP-NWC-G, CMP-NWC-F, CMP-NWC-R Districts – Vehicle: No requirement • Bicycle: 1/10,000 s.f. GFA (0/100)</i>	NP	P-ZP	P-ZP	P-ZP	P-ZP	P-ZP	P-ZP	P-ZP	
	City Park*	NP	NP	NP	NP	NP	NP	NP	NP	
	Open Space - Conservation* <i>• No Parking Requirements</i>	P-ZP	P-ZP	P-ZP	P-ZP	P-ZP	P-ZP	P-ZP	P-ZP	

KEY: \* = Need Not be Enclosed P = Permitted Use without Limitations L = Permitted Use with Limitations NP = Not Permitted Use ZP = Zoning Permit Review ZPCIM = Subject to Zoning Permit Review with Community Information Meeting ZPIN = Subject to Zoning Permit Review with Informational Notice ZPSE = Subject to Zoning Permit with Special Exception Review When no ZP, ZPCIM, ZPIN, ZPSE listed = No Zoning Permit required

USE CATEGORY	SPECIFIC USE TYPE <ul style="list-style-type: none"> <li>Vehicle Parking Requirement – # of spaces per unit of measurement</li> <li>Bicycle Parking Requirement – # of spaces per unit of measurement (% required spaces in indoor facility/% required spaces in fixed facility)</li> </ul>	APPLICABLE USE LIMITATIONS								
		CMP-H CMP-H2	CMP-EI CMP-EI2	CMP-ENT	CMP-NWC	CMP-NWC-C	CMP-NWC-G	CMP-NWC-F	CMP-NWC-R	
Education	Elementary or Secondary School <ul style="list-style-type: none"> <li>Vehicle: 1/1,000 s.f. GFA</li> <li>CMP-NWC-C, CMP-NWC-G, CMP-NWC-F, CMP-NWC-R Districts – Vehicle: No requirement</li> <li>Bicycle – High School: 1/5,000 s.f. GFA (0/100)</li> <li>Bicycle – All Others: 1/10,000 s.f. GFA (0/100)</li> </ul>	P-ZP	P-ZP	NP	P-ZP	P-ZP	P-ZP	P-ZP	P-ZP	
	University or College <ul style="list-style-type: none"> <li>Vehicle: 1/1,000 s.f. GFA</li> <li>CMP-NWC-C, CMP-NWC-G, CMP-NWC-F, CMP-NWC-R Districts – Vehicle: No requirement</li> <li>Bicycle: 1/10,000 s.f. GFA (0/100)</li> </ul>	P-ZP	P-ZP	NP	P-ZP	P-ZP	P-ZP	P-ZP	P-ZP	
	Vocational or Professional School <ul style="list-style-type: none"> <li>Vehicle: 1/1,000 s.f. GFA</li> <li>CMP-NWC-C, CMP-NWC-G, CMP-NWC-F, CMP-NWC-R Districts – Vehicle: No requirement</li> <li>Bicycle: 1/10,000 s.f. GFA (0/100)</li> </ul>	P-ZP	P-ZP	NP	P-ZP	P-ZP	P-ZP	P-ZP	P-ZP	
Public and Religious Assembly	All Types <ul style="list-style-type: none"> <li>No Parking Requirements</li> </ul>	P-ZP	P-ZP	P-ZP	P-ZP	P-ZP	P-ZP	P-ZP	P-ZP	
COMMERCIAL SALES, SERVICES, & REPAIR PRIMARY USE CLASSIFICATION										
Adult Business	All Types	NP	NP	NP	NP	NP	NP	NP	NP	See Section 9.4.4, Use Overlay Districts, for adult business use allowance in the UO-1 District.
Arts, Recreation & Entertainment	Arts, Recreation and Entertainment Services, Indoor <ul style="list-style-type: none"> <li>Vehicle – Artist Studio: 0.3/1000 sf GFA</li> <li>Vehicle – All Others: 1.25/1,000 s.f. GFA</li> <li>CMP-NWC-C, CMP-NWC-G, CMP-NWC-F, CMP-NWC-R Districts – Vehicle: No requirement</li> <li>Bicycle: 1/7,500 s.f. GFA (20/80)</li> </ul>	NP	P-ZP	P-ZP	P-ZP	P-ZP	P-ZP	P-ZP	P-ZP	
	Arts, Recreation and Entertainment Services, Outdoor* <ul style="list-style-type: none"> <li>Vehicle: 1.25/1,000 s.f. GFA</li> <li>CMP-NWC-C, CMP-NWC-G, CMP-NWC-F, CMP-NWC-R Districts – Vehicle: No requirement</li> <li>Bicycle: 1/7,500 s.f. GFA (20/80)</li> </ul>	NP	NP	L-ZP	L-ZP	P-ZP	P-ZP	P-ZP	P-ZP	§11.4.3
	Event Space with Alternate Parking and Loading* <ul style="list-style-type: none"> <li>Vehicle: No requirement</li> <li>Bicycle: No requirement</li> </ul>	NP	NP	NP	NP	NP	L-ZP	L-ZP	NP	§11.4.4
	Sports and/or Entertainment Arena or Stadium* <ul style="list-style-type: none"> <li>Vehicle: 1.25/1,000 s.f. GFA</li> <li>CMP-NWC-C, CMP-NWC-G, CMP-NWC-F, CMP-NWC-R Districts – Vehicle: No requirement</li> <li>Bicycle: 1/7,500 s.f. GFA (20/80)</li> </ul>	NP	NP	P-ZP	P-ZP	P-ZP	P-ZP	P-ZP	NP	
Nonresidential Uses in Existing Business Structures In Residential Zones (All Uses Shall Be Parked According to the Parking Requirement Stated in this Use Table for the Specific Nonresidential Use)		Not Applicable								
Parking of Vehicles	Parking, Garage <ul style="list-style-type: none"> <li>No Parking Requirements</li> </ul>	P-ZP	P-ZP	P-ZP	P-ZP	P-ZP	P-ZP	P-ZP	NP	
	Parking, Surface* <ul style="list-style-type: none"> <li>No Parking Requirements</li> </ul>	L-ZP	L-ZP	P-ZP	P-ZP	NP	P-ZP	P-ZP	NP	§11.4.8

KEY: \* = Need Not be Enclosed P = Permitted Use without Limitations L = Permitted Use with Limitations NP = Not Permitted Use ZP = Zoning Permit Review ZPCIM = Subject to Zoning Permit Review with Community Information Meeting ZPIN = Subject to Zoning Permit Review with Informational Notice ZPSE = Subject to Zoning Permit with Special Exception Review When no ZP, ZPCIM, ZPIN, ZPSE listed = No Zoning Permit required

USE CATEGORY	SPECIFIC USE TYPE <i>• Vehicle Parking Requirement – # of spaces per unit of measurement • Bicycle Parking Requirement – # of spaces per unit of measurement (% required spaces in indoor facility/% required spaces in fixed facility)</i>	SPECIFIC USE TYPE								APPLICABLE USE LIMITATIONS
		CMP-H CMP-H2	CMP-EI CMP-EI2	CMP-ENT	CMP-NWC	CMP-NWC-C	CMP-NWC-G	CMP-NWC-F	CMP-NWC-R	
Eating & Drinking Establishments	All Types <i>• Vehicle: 2.5/1,000 s.f. GFA • CMP-NWC-C, CMP-NWC-G, CMP-NWC-F, CMP-NWC-R Districts – Vehicle: No requirement • Bicycle: 1/1,500 s.f. GFA (0/100)</i>	H: P-ZP H2: L-ZP	EI: P-ZP EI2: L-ZP	P-ZP	P-ZP	P-ZP	P-ZP	P-ZP	P-ZP	\$11.4.9
Lodging Accommodations	Bed and Breakfast Lodging <i>• Vehicle: 0.875/guest room or unit • CMP-NWC-C, CMP-NWC-G, CMP-NWC-F, CMP-NWC-R Districts – Vehicle: No requirement • Bicycle: 1/7,500 s.f. GFA (60/40)</i>	P-ZP	EI: P-ZP EI2: NP	P-ZP	P-ZP	P-ZP	P-ZP	P-ZP	NP	
	Lodging Accommodations, All Others <i>• Vehicle: 0.5/ guest room or unit • CMP-NWC-C, CMP-NWC-G, CMP-NWC-F, CMP-NWC-R Districts – Vehicle: No requirement • Bicycle: 1/7,500 s.f. GFA (60/40)</i>	P-ZPIN	EI: P-ZPIN EI2: NP	P-ZP	P-ZP	P-ZP	P-ZP	P-ZP	NP	
Office	Dental / Medical Office or Clinic <i>• Vehicle: 2.5/ 1,000 s.f. GFA • CMP-NWC-C, CMP-NWC-G, CMP-NWC-F, CMP-NWC-R Districts – Vehicle: No requirement • Bicycle: 1/7,500 s.f. GFA (60/40)</i>	L-ZP	L-ZP/P-ZPIN	NP	L-ZP	P-ZP	P-ZP	P-ZP	NP	\$11.4.10
	Office, All Others <i>• Vehicle: 2.5/ 1,000 s.f. GFA • CMP-NWC-C, CMP-NWC-G, CMP-NWC-F, CMP-NWC-R Districts – Vehicle: No requirement • Bicycle: 1/7,500 s.f. GFA (60/40)</i>	P-ZP	P-ZP	P-ZP	P-ZP	P-ZP	P-ZP	P-ZP	NP	
Retail Sales, Service & Repair (Not Including Vehicle or Equipment Sales, Service & Repair)	Animal Sales and Services, Household Pets Only <i>• Vehicle: 1.25/1,000 s.f. GFA • CMP-NWC-C, CMP-NWC-G, CMP-NWC-F, CMP-NWC-R Districts – Vehicle: No requirement • Bicycle: 1/7,500 s.f. GFA (20/80)</i>	NP	NP	NP	P-ZP	P-ZP	P-ZP	P-ZP	NP	
	Animal Sales and Services, All Others* <i>• Vehicle: 1.25/1,000 s.f. GFA • CMP-NWC-C, CMP-NWC-G, CMP-NWC-F, CMP-NWC-R Districts – Vehicle: No requirement • Bicycle: 1/7,500 s.f. GFA (20/80)</i>	NP	NP	NP	L-ZP	P-ZP	P-ZP	P-ZP	NP	
	Food Sales or Market* <i>• Vehicle: 1.25/1,000 s.f. GFA • CMP-NWC-C, CMP-NWC-G, CMP-NWC-F, CMP-NWC-R Districts – Vehicle: No requirement • Bicycle: 1/7,500 s.f. GFA (20/80)</i>	NP	NP	NP	P-ZP	P-ZP	P-ZP	P-ZP	P-ZP	
	Pawn Shop	NP	NP	NP	NP	NP	NP	NP	NP	
	Retail Sales, Service & Repair -- Outdoor* <i>• Vehicle: 1.25/1,000 s.f. GFA • CMP-NWC-C, CMP-NWC-G, CMP-NWC-F, CMP-NWC-R Districts – Vehicle: No requirement • Bicycle: 1/7,500 s.f. GFA (20/80)</i>	NP	NP	NP	L-ZP	NP	L-ZP	L-ZP	NP	\$11.4.16
	Retail Sales, Service & Repair - Firearms Sales <i>• Vehicle: 1.25/1,000 s.f. GFA • CMP-NWC-C, CMP-NWC-G, CMP-NWC-F, CMP-NWC-R Districts – Vehicle: No requirement • Bicycle: 1/7,500 s.f. GFA (20/80)</i>	NP	NP	NP	P-ZP	P-ZP	P-ZP	P-ZP	NP	
Retail Sales, Service & Repair, All Others <i>• Vehicle: 1.25/1,000 s.f. GFA • Bicycle: 1/7,500 s.f. GFA (20/80)</i>	ZPIN	NP	P-ZP	P-ZP	P-ZP	P-ZP	P-ZP	P-ZP		

KEY: \* = Need Not be Enclosed P = Permitted Use without Limitations L = Permitted Use with Limitations NP = Not Permitted Use ZP = Zoning Permit Review ZPCIM = Subject to Zoning Permit Review with Community Information Meeting ZPIN = Subject to Zoning Permit Review with Informational Notice ZPSE = Subject to Zoning Permit with Special Exception Review When no ZP, ZPCIM, ZPIN, ZPSE listed = No Zoning Permit required

USE CATEGORY	SPECIFIC USE TYPE <i>• Vehicle Parking Requirement – # of spaces per unit of measurement • Bicycle Parking Requirement – # of spaces per unit of measurement (% required spaces in indoor facility/% required spaces in fixed facility)</i>	APPLICABLE USE LIMITATIONS								
		CMP-H CMP-H2	CMP-EI CMP-EI2	CMP-ENT	CMP-NWC	CMP-NWC-C	CMP-NWC-G	CMP-NWC-F	CMP-NWC-R	
Vehicle / Equipment Sales, Rentals, Service & Repair	Automobile Emissions Inspection Facility	NP	NP	NP	NP	NP	NP	NP	NP	
	Automobile Services, Light	NP	NP	NP	NP	NP	NP	L-ZP	NP	\$11.4.18
	Automobile Services, Heavy	NP	NP	NP	NP	NP	NP	L-ZP	NP	\$11.4.18
	Automobile / Motorcycle / Light Truck Sales, Rentals, Leasing; Pawn Lot or Vehicle Auctioneer*	NP	NP	NP	NP	NP	NP	NP	NP	
	Heavy Vehicle/ Equipment Sales, Rentals & Service*	NP	NP	NP	NP	NP	NP	NP	NP	
<b>INDUSTRIAL, MANUFACTURING &amp; WHOLESALE PRIMARY USE CLASSIFICATION</b>										
Communications and Information	Antennas Not Attached to a Tower* <i>• No Parking Requirements</i>	L-ZP	L-ZP	L-ZP	L-ZP	L-ZP	L-ZP	L-ZP	L-ZP	\$11.5.2
	Communication Services <i>• Vehicle: .5/1,000 s.f. GFA • CMP-NWC-C, CMP-NWC-G, CMP-NWC-F, CMP-NWC-R Districts – Vehicle: No requirement • Bicycle: No requirement</i>	P-ZP	P-ZP	P-ZP	P-ZP	P-ZP	P-ZP	P-ZP	NP	\$11.5.1
	Telecommunications Towers* <i>• No Parking Requirements</i>	L-ZP/ ZPIN/ ZPSE	L-ZP/ ZPIN/ ZPSE	L-ZP/ ZPIN/ ZPSE	L-ZP/ ZPIN/ ZPSE	L-ZP/ ZPIN/ ZPSE	L-ZP/ ZPIN/ ZPSE	L-ZP/ ZPIN/ ZPSE	L-ZP/ ZPIN/ ZPSE	\$11.5.2
	Telecommunications Tower - Alternative Structure <i>• No Parking Requirements</i>	L-ZP/ ZPIN	L-ZP/ ZPIN	L-ZP/ ZPIN	L-ZP/ ZPIN	L-ZP/ ZPIN	L-ZP/ ZPIN	L-ZP/ ZPIN	L-ZP/ ZPIN	\$11.5.2
	Telecommunication Facilities -- All Others* <i>• No Parking Requirements</i>	L-ZP	L-ZP	L-ZP	L-ZP	L-ZP	L-ZP	L-ZP	L-ZP	\$11.5.2
Industrial Services	Contractors, Special Trade - General	NP	NP	NP	NP	NP	NP	L-ZP	NP	\$11.5.3
	Contractors, Special Trade - Heavy/ Contractor Yard*	NP	NP	NP	NP	NP	NP	L-ZP	NP	\$11.5.4
	Food Preparation and Sales, Commercial <i>• Vehicle: .5/1,000 s.f. GFA • CMP-NWC-C, CMP-NWC-G, CMP-NWC-F, CMP-NWC-R Districts – Vehicle: No requirement • Bicycle: No requirement</i>	NP	NP	NP	L-ZP	L-ZP	L-ZP	L-ZP	NP	\$11.5.5
	Laboratory, Research, Development and Technological Services <i>• Vehicle: .5/1,000 s.f. GFA • CMP-NWC-C, CMP-NWC-G, CMP-NWC-F, CMP-NWC-R Districts – Vehicle: No requirement • Bicycle: No requirement</i>	P-ZPIN	EI: P-ZPIN EI2: NP	L-ZP	P-ZP	P-ZP	P-ZP	P-ZP	P-ZP	\$11.5.6
	Service/Repair, Commercial	NP	NP	NP	NP	NP	NP	L-ZP	NP	\$11.5.7
Manufacturing and Production	Manufacturing, Fabrication & Assembly -- Custom <i>• Vehicle: .5/1,000 s.f. GFA • CMP-NWC-C, CMP-NWC-G, CMP-NWC-F, CMP-NWC-R Districts – Vehicle: No requirement • Bicycle: No requirement</i>	NP	NP	NP	L-ZP	L-ZP	L-ZP	L-ZP	NP	\$11.5.8
	Manufacturing, Fabrication & Assembly -- General <i>• Vehicle: .5/1,000 s.f. GFA • CMP-NWC-C, CMP-NWC-G, CMP-NWC-F, CMP-NWC-R Districts – Vehicle: No requirement • Bicycle: No requirement</i>	NP	NP	NP	L-ZP/ ZPSE	L-ZP/ ZPSE	L-ZP/ ZPSE	L-ZP/ ZPSE	NP	\$11.5.9
	Manufacturing, Fabrication & Assembly -- Heavy	NP	NP	NP	NP	NP	NP	NP	NP	
Mining & Extraction and Energy Producing Systems	Oil, Gas -- Production, Drilling*	NP	NP	NP	NP	NP	NP	NP	NP	
	Sand or Gravel Quarry*	NP	NP	NP	NP	NP	NP	NP	NP	
	Wind Energy Conversion Systems* <i>• No Parking Requirements</i>	L-ZP	L-ZP	L-ZP	L-ZP	L-ZP	L-ZP	L-ZP	L-ZP	\$11.5.13

KEY: \* = Need Not be Enclosed P = Permitted Use without Limitations L = Permitted Use with Limitations NP = Not Permitted Use ZP = Zoning Permit Review ZPCIM = Subject to Zoning Permit Review with Community Information Meeting ZPIN = Subject to Zoning Permit Review with Informational Notice ZPSE = Subject to Zoning Permit with Special Exception Review When no ZP, ZPCIM, ZPIN, ZPSE listed = No Zoning Permit required

USE CATEGORY	SPECIFIC USE TYPE <i>• Vehicle Parking Requirement – # of spaces per unit of measurement • Bicycle Parking Requirement – # of spaces per unit of measurement (% required spaces in indoor facility/% required spaces in fixed facility)</i>	CAMP-H								APPLICABLE USE LIMITATIONS	
		CMP-H2	CMP-EI CMP-EI2	CMP-ENT	CMP-NWC	CMP-NWC-C	CMP-NWC-G	CMP-NWC-F	CMP-NWC-R		
Transportation Facilities	Airport*	NP	NP	NP	NP	NP	NP	NP	NP		
	Helipad, Helistop, Heliport* <i>• No Parking Requirements</i>	L-ZP/ ZPSE	L-ZP	L-ZP	L-ZP	L-ZP	L-ZP	L-ZP	L-ZP	NP	§11.5.14
	Railroad Facilities* <i>• Vehicle: ~3/1,000 s.f. GFA • CMP-NWC-C, CMP-NWC-G, CMP-NWC-F, CMP-NWC-R Districts – Vehicle: No requirement • Bicycle: No requirement</i>	NP	NP	NP	L-ZP	NP	L-ZP	L-ZP	NP	NP	§11.5.15
	Railway Right-of-Way* <i>• No Parking Requirements</i>	P-ZP	P-ZP	P-ZP	P-ZP	P-ZP	P-ZP	P-ZP	P-ZP	P-ZP	
	Terminal, Station or Service Facility for Passenger Transit System	NP	NP	NP	P-ZP	P-ZP	P-ZP	P-ZP	NP	NP	
	Terminal, Freight, Air Courier Services	NP	NP	NP	NP	NP	NP	NP	NP	NP	
Waste Related Services	Automobile Parts Recycling Business	NP	NP	NP	NP	NP	NP	NP	NP	NP	
	Junkyard*	NP	NP	NP	NP	NP	NP	NP	NP	NP	
	Recycling Center <i>• Vehicle: ~3/1,000 s.f. GFA • CMP-NWC-C, CMP-NWC-G, CMP-NWC-F, CMP-NWC-R Districts – Vehicle: No requirement • Bicycle: No requirement</i>	NP	NP	NP	L-ZP	NP	L-ZP	L-ZP	NP	NP	§11.5.20
	Recycling Collection Station <i>• Vehicle: ~3/1,000 s.f. GFA • CMP-NWC-C, CMP-NWC-G, CMP-NWC-F, CMP-NWC-R Districts – Vehicle: No requirement • Bicycle: No requirement</i>	NP	NP	NP	P-ZP	NP	P-ZP	P-ZP	NP	NP	
	Recycling Plant, Scrap Processor	NP	NP	NP	NP	NP	NP	NP	NP	NP	
Wholesale, Storage, Warehouse & Distribution	Solid Waste Facility	NP	NP	NP	NP	NP	NP	NP	NP	NP	
	Automobile Towing Service Storage Yard*	NP	NP	NP	NP	NP	NP	NP	NP	NP	
	Mini-storage Facility	NP	NP	NP	NP	NP	NP	NP	NP	NP	
	Vehicle Storage, Commercial*	NP	NP	NP	NP	NP	NP	L-ZP	NP	NP	§11.5.24
	Wholesale Trade or Storage, General <i>• Vehicle: ~3/1,000 s.f. GFA • CMP-NWC-C, CMP-NWC-G, CMP-NWC-F, CMP-NWC-R Districts – Vehicle: No requirement • Bicycle: No requirement</i>	NP	NP	NP	L-ZP	NP	NP	L-ZP	NP	NP	§11.5.26

KEY: \* = Need Not be Enclosed P = Permitted Use without Limitations L = Permitted Use with Limitations NP = Not Permitted Use ZP = Zoning Permit Review ZPCIM = Subject to Zoning Permit Review with Community Information Meeting ZPIN = Subject to Zoning Permit Review with Informational Notice ZPSE = Subject to Zoning Permit with Special Exception Review When no ZP, ZPCIM, ZPIN, ZPSE listed = No Zoning Permit required

USE CATEGORY	SPECIFIC USE TYPE <i>• Vehicle Parking Requirement - # of spaces per unit of measurement • Bicycle Parking Requirement - # of spaces per unit of measurement (% required spaces in indoor facility/% required spaces in fixed facility)</i>	APPLICABLE USE LIMITATIONS								APPLICABLE USE LIMITATIONS
		CMP-H CMP-H2	CMP-EI CMP-EI2	CMP-ENT	CMP-NWC	CMP-NWC-C	CMP-NWC-G	CMP-NWC-F	CMP-NWC-R	
<b>AGRICULTURE PRIMARY USE CLASSIFICATION</b>										
Agriculture	Aquaculture* <i>• Vehicle: .5/1,000 s.f. GFA • CMP-NWC-C, CMP-NWC-G, CMP-NWC-F, CMP-NWC-R Districts - Vehicle: No requirement • Bicycle: No requirement</i>	NP	NP	NP	L-ZP	L-ZP	L-ZP	L-ZP	NP	\$11.6.1
	Garden, Urban* <i>• Vehicle: .5/1,000 s.f. GFA • CMP-NWC-C, CMP-NWC-G, CMP-NWC-F, CMP-NWC-R Districts - Vehicle: No requirement • Bicycle: No requirement</i>	L-ZP	L-ZP	L-ZP	L-ZP	L-ZP	L-ZP	L-ZP	L-ZP	\$11.6.2
	Husbandry, Animal* <i>• Vehicle: .5/1,000 s.f. GFA • CMP-NWC-C, CMP-NWC-G, CMP-NWC-F, CMP-NWC-R Districts - Vehicle: No requirement • Bicycle: No requirement</i>	NP	NP	NP	L-ZP	L-ZP	L-ZP	L-ZP	NP	\$11.6.3
	Husbandry, Plant* Plant Nursery <i>• Vehicle: .5/1,000 s.f. GFA • CMP-NWC-C, CMP-NWC-G, CMP-NWC-F, CMP-NWC-R Districts - Vehicle: No requirement • Bicycle: No requirement</i>	NP	NP	L-ZP	L-ZP	L-ZP	L-ZP	L-ZP	NP	\$11.6.5
<b>ACCESSORY TO PRIMARY RESIDENTIAL USES USE CLASSIFICATION</b>										
Accessory to Primary Residential Uses <i>(Parking is Not Required for Accessory Uses Unless Specifically Stated in this Table or in an Applicable Use Limitation)</i>	Unlisted Accessory Uses	L - Applicable to all Zone Districts								\$11.7
	Accessory Dwelling Unit <i>• Vehicle: 1/Unit • CMP-NWC-C, CMP-NWC-G, CMP-NWC-F, CMP-NWC-R Districts - Vehicle: No requirement • Bicycle: No requirement</i>	L-ZP	L-ZP	L-ZP	L-ZP	L-ZP	L-ZP	L-ZP	NP	\$11.7; \$11.8.2
	Domestic Employee	L	L	L	L	L	L	L	NP	\$11.8.3
	Garden*	L	L	L	L	L	L	L	NP	\$11.7; \$11.8.4
	Keeping of Household Animals*	L / L-ZPIN	L / L-ZPIN	L / L-ZPIN	L / L-ZPIN	L / L-ZPIN	L / L-ZPIN	L / L-ZPIN	NP	\$11.7; \$11.8.5
	Keeping and Off-Street Parking of Vehicles, Motorcycles, Trailers & Recreational Vehicles*	NP	NP	NP	NP	L	L	L	NP	\$11.7; \$10.9
	Kennel or Exercise Run*	L	L	L	L	L	L	L	NP	\$11.7; \$11.8.6
	Limited Commercial Sales, Services Accessory to Multi-Unit Dwelling Use	L-ZP	L-ZP	L-ZP	L-ZP	L-ZP	L-ZP	L-ZP	NP	\$11.7; \$11.8.7
	Outdoor Storage, Residential	L	L	L	L	L	L	L	NP	\$11.7; \$11.8.8
	Second Kitchen Accessory to Single Unit Dwelling Use	L-ZP	L-ZP	L-ZP	L-ZP	L-ZP	L-ZP	L-ZP	NP	\$11.7; \$11.8.9
	Short-term Rental	L	L	L	L	L	L	L	NP	\$11.7; \$11.8.10
Vehicle Storage, Repair and Maintenance Accessory to a Dwelling Use*	L	L	L	L	L	L	L	NP	\$11.7; \$10.9	
Wind Energy Conversion Systems*	Not Applicable - See Permitted Primary Uses									
Yard or Garage Sales*	L	L	L	L	L	L	L	NP	\$11.7; \$11.8.11	
<b>HOME OCCUPATIONS ACCESSORY TO PRIMARY RESIDENTIAL USES USE CLASSIFICATION</b>										
Home Occupations	Child Care Home, Large	L-ZP	L-ZP	L-ZP	L-ZP	L-ZP	L-ZP	L-ZP	NP	\$11.9; \$11.9.3
	All Other Types	L-ZP	L-ZP	L-ZP	L-ZP	L-ZP	L-ZP	L-ZP	NP	\$11.9; \$11.9.4
	Unlisted Home Occupations	L-ZPIN - Applicable to all Zone Districts								\$11.9; \$11.9.5

KEY: \* = Need Not be Enclosed P = Permitted Use without Limitations L = Permitted Use with Limitations NP = Not Permitted Use ZP = Zoning Permit Review ZPCIM = Subject to Zoning Permit Review with Community Information Meeting ZPIN = Subject to Zoning Permit Review with Informational Notice ZPSE = Subject to Zoning Permit with Special Exception Review When no ZP, ZPCIM, ZPIN, ZPSE listed = No Zoning Permit required

USE CATEGORY	SPECIFIC USE TYPE • <del>Vehicle Parking Requirement - # of spaces per unit of measurement</del> • <del>Bicycle Parking Requirement - # of spaces per unit of measurement (% required spaces in indoor facility/% required spaces in fixed facility)</del>	APPLICABLE USE LIMITATIONS								
		CMP-H CMP-H2	CMP-EI CMP-EI2	CMP-ENT	CMP-NWC	CMP-NWC-C	CMP-NWC-G	CMP-NWC-F	CMP-NWC-R	
<b>ACCESSORY TO PRIMARY NONRESIDENTIAL USES USE CLASSIFICATION</b>										
Accessory to Primary Nonresidential Uses  (Parking is Not Required for Accessory Uses Unless Specifically Stated in this Table or in an Applicable Use Limitation)	Unlisted Accessory Uses	L - Applicable to all Zone Districts								\$11.7; §11.10.1
	Amusement Devices Accessory to Eating / Drinking Establishments, College / University and Theater Uses	L-ZP	L-ZP	L-ZP	L-ZP	L-ZP	L-ZP	L-ZP	L-ZP	\$11.7; §11.10.2
	Automobile Rental Services Accessory to Certain Retail Uses*	L	L	L	L	L	L	L	NP	\$11.7; §11.10.3
	Book or gift store; media recording and production facilities accessory to public libraries, museums, places of religious assembly, colleges or universities	L	L	L	L	L	L	L	L	§ 11.7
	Car Wash Bay Accessory to Automobile Services	L-ZP	L-ZP	L-ZP	NP	NP	NP	L-ZP	NP	\$11.7; §11.10.5
	College Accessory to a Place for Religious Assembly	L	L	NP	L	L	L	L	NP	\$11.7; §11.10.6
	Conference Facilities Accessory to Hotel Use	L	L	L	L	L	L	L	NP	\$11.7; §11.10.7
	Drive Through Facility Accessory to Eating / Drinking Establishments and to Retail Sales, Service, and Repair Uses*	L-ZP	L-ZP	L-ZP	L-ZP	L-ZP	L-ZP	L-ZP	NP	\$11.7; §11.10.8
	Emergency Vehicle Access Point Garden*	L-ZPSE	NP	NP	NP	NP	NP	NP	NP	\$11.7; §11.10.9
	Keeping of Animals	L/L-ZP/ L-ZPIN	L/L-ZP/ L-ZPIN	L/L-ZP/ L-ZPIN	L/L-ZP/ L-ZPIN	L	L	L	L	\$11.7; § 11.10.11
	Limited Commercial Sales, Services	L	L	L	L	L	L	L	L	\$11.7; §11.10.12
	Nonresidential Uses in Existing Business Structures In Residential Zones - Accessory Uses	Not Applicable								
	Occasional Sales, Services	L	L	L	L	L	L	L	L	\$11.7; §11.10.13
	Accessory to Primary Places of Religious Assembly or Primary Uses Operated by Nonprofit Organizations*	L/L-ZP/ L-ZPIN	L/L-ZP/ L-ZPIN	L/L-ZP/ L-ZPIN	L/L-ZP/ L-ZPIN	L/L-ZP/ L-ZPIN	L/L-ZP/ L-ZPIN	L/L-ZP/ L-ZPIN	L/L-ZP/ L-ZPIN	\$11.7; §11.10.14
	Outdoor Entertainment Accessory to Eating / Drinking Establishments Use*	L-ZPIN/ ZPSE	L-ZPIN/ ZPSE	L-ZPIN/ ZPSE	L-ZPIN/ ZPSE	L-ZPIN/ ZPSE	L-ZPIN/ ZPSE	L-ZPIN/ ZPSE	L-ZPIN/ ZPSE	\$11.7; §11.10.15
	Outdoor Retail Sale and Display*	L-ZP/ ZPSE	L-ZP/ ZPSE	L-ZP/ ZPSE	L-ZP/ ZPSE	L-ZP/ ZPSE	L-ZP/ ZPSE	L-ZP/ ZPSE	L-ZP/ ZPSE	\$11.7; §11.10.16
	Outdoor Storage, General*	NP	NP	NP	NP	NP	NP	L-ZP	NP	\$11.7; §11.10.17
	Outdoor Storage, Limited*	L-ZP	L-ZP	L-ZP	L-ZP	L-ZP	L-ZP	L-ZP	NP	\$11.7; §11.10.18
Rental or Sales of Adult Material Accessory to a Permitted Bookstore Retail Sales Use	L	L	L	L	L	L	L	L	\$11.7; §11.10.19	
Retail Food Establishment, Mobile (Food Truck)*	L-ZP	L-ZP	L-ZP	L-ZP	L-ZP	L-ZP	L-ZP	L-ZP	\$11.7; §11.10.20	

KEY: \* = Need Not be Enclosed P = Permitted Use without Limitations L = Permitted Use with Limitations NP = Not Permitted Use ZP = Zoning Permit Review  
 ZPCIM = Subject to Zoning Permit Review with Community Information Meeting ZPIN = Subject to Zoning Permit Review with Informational Notice  
 ZPSE = Subject to Zoning Permit with Special Exception Review When no ZP, ZPCIM, ZPIN, ZPSE listed = No Zoning Permit required

USE CATEGORY	SPECIFIC USE TYPE <ul style="list-style-type: none"> <li>• <del>Vehicle Parking Requirement - # of spaces per unit of measurement</del></li> <li>• <del>Bicycle Parking Requirement - # of spaces per unit of measurement (% required spaces in indoor facility/% required spaces in fixed facility)</del></li> </ul>	CAMP-H CMP-H2    CMP-EI    CMP-ENT    CMP-NWC    CMP-NWC-C    CMP-NWC-G    CMP-NWC-F    CMP-NWC-R								APPLICABLE USE LIMITATIONS
		CMP-H2	CMP-EI	CMP-ENT	CMP-NWC	CMP-NWC-C	CMP-NWC-G	CMP-NWC-F	CMP-NWC-R	
<b>TEMPORARY USE CLASSIFICATION</b>										
Temporary Uses	Unlisted Temporary Uses	L - Applicable in all Zone Districts								§11.11.1
	Ambulance Service - Temporary	Not Applicable - See Permitted Primary Uses								§11.11.2
	Amusement / Entertainment - Temporary*	L-ZP	P-ZP	P-ZP	L-ZP	L-ZP	L-ZP	L-ZP	L-ZP	§11.11.3
	Bazaar, Carnival, Circus or Special Event*	L-ZP	L-ZP	L-ZP	L-ZP	L-ZP	L-ZP	L-ZP	L-ZP	§11.11.4
	Building or Yard for Construction Materials*	L-ZP	L-ZP	L-ZP	L-ZP	L-ZP	L-ZP	L-ZP	L-ZP	§11.11.5
	Concrete, Asphalt, and Rock Crushing Facility*	L-ZP	L-ZP	L-ZP	L-ZP	L-ZP	L-ZP	L-ZP	L-ZP	§11.11.6
	Fence for Demolition or Construction Work	L-ZP	L-ZP	L-ZP	L-ZP	L-ZP	L-ZP	L-ZP	L-ZP	§11.11.7
	Health Care Center	P-ZP	P-ZP	P-ZP	P-ZP	L-ZP	L-ZP	L-ZP	L-ZP	§11.11.8
	Noncommercial Concrete Batching Plant*	L-ZP	L-ZP	L-ZP	L-ZP	L-ZP	L-ZP	L-ZP	L-ZP	§11.11.9
	Outdoor Retail Sales - Pedestrian / Transit Mall*	L-ZP	L-ZP	L-ZP	L-ZP	L-ZP	L-ZP	L-ZP	L-ZP	§11.11.10
	Outdoor Retail Sales*	L-ZP	L-ZP	L-ZP	L-ZP	L-ZP	L-ZP	L-ZP	L-ZP	§11.11.11
	Outdoor Sales, Seasonal*	L-ZP	L-ZP	L-ZP	L-ZP	L-ZP	L-ZP	L-ZP	L-ZP	§11.11.12
	Parking Lot Designated for a Special Event*	L-ZP	L-ZP	L-ZP	L-ZP	L-ZP	L-ZP	L-ZP	NP	§11.11.13
	Retail Food Establishment, Mobile (Food Truck)*	L/L-ZP	L/L-ZP	L/L-ZP	L/L-ZP	L/L-ZP	L/L-ZP	L/L-ZP	L/L-ZP	§11.11.14
	Temporary Construction Office	L-ZP	L-ZP	L-ZP	L-ZP	L-ZP	L-ZP	L-ZP	L-ZP	§11.11.15
	Temporary Office - Real Estate Sales	L-ZP	L-ZP	L-ZP	L-ZP	L-ZP	L-ZP	L-ZP	L-ZP	§11.11.16
Temporary Managed Community*	L-ZPCIM	L-ZPCIM	L-ZPCIM	L-ZPCIM	L-ZPCIM	L-ZPCIM	L-ZPCIM	L-ZPCIM	§11.11.17	
Tent for Religious Services	P-ZP	P-ZP	P-ZP	L-ZP	L-ZP	L-ZP	L-ZP	L-ZP	§11.11.18	



### 9.3.3.2 Primary Building Forms in OS-B and OS-C

The General building form, as stated below, is allowed in the OS-B and OS-C zone districts. See also Section 1.2.3.5 related to the maximum number of structures and uses allowed per Zone Lot.

See also Division 1.4, Building Form Standards - General Provisions, for additional standards related to initial assignment of building form standards to new and existing structures and for rules governing combining or changing building forms.

## GENERAL

HEIGHT	OS-B, OS-C
Stories (max)	3
Feet, pitched or Low-Slope Roof (max)	40'
SITING	OS-B, OS-C
SETBACKS	
Primary Street (min)	20'
Side Street (min)	20'
Side, interior (min)	20'
Rear (min)	20'
PARKING	
Primary Street Setback (min)	30'
Side Street Setback (min)	10'
Setback Adjacent Protected District (min)	5'
DESIGN ELEMENTS	OS-B, OS-C
Required Entrance, Primary Street	No
USES	OS-B, OS-C
	All permitted Uses shall be allowed within this building form. See Section 9.3.4, <a href="#">Uses, and Required Minimum Parking</a>

### 9.3.3.3 Design Standard Exceptions

#### A. Height Exceptions

##### 1. Intent

To allow building features to exceed maximum height for utility purposes and/or limited recreation or building amenities in the higher intensity zone districts/larger forms.

##### 2. Standard

Except as specifically allowed below:

- a. No portion of a structure shall project beyond the maximum height in feet specified in the applicable Building Form table.

BUILDING FEATURES	ZONE DISTRICTS	THE AGGREGATE SHALL NOT EXCEED 33-1/3 PERCENT OF THE AREA OF THE SUPPORTING ROOF	SHALL BE SET BACK FROM THE PERIMETER OF THE BUILDING A MINIMUM OF ONE FOOT HORIZONTALLY FOR EVERY ONE FOOT OF VERTICAL HEIGHT	MAY EXCEED MAXIMUM HEIGHT IN FEET BY:	MAY EXCEED MAXIMUM HEIGHT IN STORIES BY:	MAY PROJECT THROUGH THE BULK PLANE	MAY EXCEED UPPER STORY SETBACK HEIGHT BY
Parapet Wall or Safety Railing	OS-B, OS-C	No	No	Any distance	Not applicable	Any distance	4'
Solar panels	OS-B, OS-C	No	No	Any distance	Not applicable	Any distance	Any distance
Evaporative coolers	OS-B, OS-C	No	Yes	Any distance	Not applicable	Any distance	Any distance
Accessory water tanks	OS-B, OS-C	No	Yes	28'	Not applicable	Any distance	Any distance

## SECTION 9.3.4 USES ~~AND REQUIRED MINIMUM PARKING~~

### 9.3.4.1 Applicability

#### A. OS-A Zone District

Permitted uses, number of uses and applicable use limitations, in the OS-A zone district, shall be determined by the manager of Parks and Recreation.

#### B. OS-B, OS-C Zone Districts

1. This Section 9.3.4 sets forth the land uses permitted; ~~and the~~ required zoning procedures ~~and the required minimum parking~~ for the OS-B; ~~and~~ OS-C zone districts.
2. Uses not listed are prohibited, unless the Zoning Administrator specifically permits the unlisted use according to Section 12.4.6, Code Interpretations and Determination of Unlisted Uses.
3. For number of primary and accessory uses allowed per Zone Lot, see Section 1.2.3.5, Number of Structures and Uses Allowed per Zone Lot.

### 9.3.4.2 Organization

#### A. Organized by Primary, Accessory and Temporary Uses

The Use ~~and Parking~~ Table first presents all primary uses, then all accessory uses, and finally all temporary uses. Primary uses are arranged hierarchically within the table by use classification, category of primary uses, and then by specific use type. Accessory uses are organized by whether such use is accessory to a primary residential use or to a primary nonresidential use. Temporary uses are presented alphabetically ordered in the last division of the table.

#### B. Primary Use Classifications, Categories & Specific Use Types

##### 1. Primary Use Classifications

All primary land uses in the Use ~~and Parking~~ Table are organized into one of the following five general land use classifications:

- a. Residential Uses
- b. Civic, Public & Institutional Uses
- c. Commercial Sales, Service & Repair Uses
- d. Industrial, Manufacturing & Wholesale Uses
- e. Agriculture

##### 2. Primary Use Categories & Specific Use Types

Primary uses are further organized into use categories and specific use types listed under each general primary land use classification. The Use ~~and Parking~~ Table is organized into the above five general land use classifications, use categories and specific use types.

### 3. Classifications & Categories Are Mutually Exclusive

The general land use classifications and use categories listed in the Use ~~and Parking~~ Table are intended to be mutually exclusive; that is, a use classified into one use category, such as “lodging accommodations,” cannot be classified in a different use category, such as “congregate living,” unless otherwise expressly allowed by this Code.

#### 9.3.4.3 Explanation of Table Abbreviations

##### A. General Explanation of Table Cell Entries

In each of the table cells, the entry will indicate first whether use limitations apply to the specific use, and then separated by a hyphen, the type of zoning review required prior to establishment of the use under this Code. For example, as described in more detail below, a cell entry “L-ZPIN” means, first, the use is subject to use limitations (the “L”), and, second, that the use is subject to zoning permit review with information notice (the “ZPIN”) prior to its establishment.

##### B. Permitted, Limited, Not Permitted

###### 1. Permitted Use - No Use Limitations Apply (“P”)

A “P” in a table cell indicates that the use is permitted in the respective zone district, and is not subject to use limitations.

###### 2. Permitted Use - Subject to Use Limitations (“L”)

“L” in a table cell indicates the use is permitted in the zone district subject to compliance with the use limitations referenced in the last column of the use table (“Applicable Use Limitations”).

###### 3. Uses Not Permitted (“NP”)

“NP” in a table cell indicates that the use is not permitted in the specific zone district.

##### C. Zoning Procedure

###### 1. Use Subject to Zoning Permit Review (“ZP”)

“ZP” in a table cell indicates that the use is permitted in the respective zone district only if reviewed and approved according to the requirements in Section 12.4.1, Zoning Permit Review.

###### 2. Use Subject to Zoning Permit Review with Informational Notice (“ZPIN”)

“ZPIN” in a table cell indicates that the use is permitted in the respective zone district only if reviewed and approved according to the public notice and procedural requirements in Section 12.4.2, Zoning Permit Review with Informational Notice. Such uses shall comply with any applicable use limitations noted in the last column of the use table (“Applicable Use Limitations”), as well as the review criteria stated in Section 12.4.2, Zoning Permit Review with Informational Notice.

###### 3. Use Subject to Zoning Permit Review with Community Information Meeting (“ZPCIM”)

“ZPCIM” in a table cell indicates that the use is permitted in the respective zone district only if reviewed and approved according to the public notice and procedural requirements in Section 12.4.1, Zoning Permit Review. Prior to formal application, an applicant shall schedule a community information meeting and provide public notice of the community information meeting according to Section 12.3.4.6, Community Information Meeting.

- 4. Use Subject to Zoning Permit with Special Exception Review (“ZPSE”)**

“ZPSE” in a table cell indicates that use is generally appropriate in the neighborhood context and zone district, yet may have the potential for limited impacts on adjacent properties or on the established character of the neighborhood context or zone district. “ZPSE” uses are subject to a Board of Adjustments public hearing according to Section 12.4.9, Zoning Permit with Special Exception Review, which grants the Board of Adjustment the authority to impose conditions on the specified use to mitigate any potential impacts. Such uses shall comply with any applicable use limitations noted in the last column of the use table (“Applicable Use Limitations”), as well as the review criteria stated in Section 12.4.9, Zoning Permit with Special Exception Review.
- 5. Uses Where More Than One Zoning Procedure Is Indicated**

Where a table cell shows more than one zoning procedure applies to a use, for example “L-ZP/ZPIN”, the referenced use limitation (last table column) will indicate which zoning procedure applies in a specific case. For example, a table cell may indicate “L-ZPIN/ZPSE” for a use. This means that the ZPIN zoning procedure will apply, unless the applicable use limitation specifies the ZPSE zoning procedure is triggered (e.g., by proximity to a Protected District).

#### 9.3.4.4 Enclosure of Uses

All primary, accessory and temporary uses must be established, operated and maintained within a Completely Enclosed Structure, unless otherwise specifically allowed by this Code. The Use ~~and Parking~~ Tables in Articles 3-9 indicate when a use may be established, operated or maintained outside a Completely Enclosed Structure by including an asterisk “\*” next to the specific use type. For example, the asterisk following the “Telecommunication Tower\*” use type in the tables indicates that a telecommunication tower land use need not be enclosed.

### 9.3.4.5 District Specific Standards

KEY: \* = Need Not be Enclosed P = Permitted Use without Limitations L = Permitted Use with Limitations NP = Not Permitted Use  
 ZP = Zoning Permit Review ZPIN = Subject to Zoning Permit Review with Informational Notice  
 ZPSE = Subject to Zoning Permit with Special Exception Review When no ZP, ZPIN, ZPSE listed = No Zoning Permit required

USE CATEGORY	SPECIFIC USE TYPE <ul style="list-style-type: none"> <li>• <del>Vehicle Parking Requirement - # of spaces per unit of measurement</del></li> <li>• <del>Bicycle Parking Requirement - # of spaces per unit of measurement (% required spaces in indoor facility / % required spaces in fixed facility)</del></li> </ul>				APPLICABLE USE LIMITATIONS
		OS-A	OS-B	OS-C	
<b>RESIDENTIAL PRIMARY USE CLASSIFICATION</b>					
Household Living	Dwelling, Single Unit	See Section 9.3.4.1	NP	NP	
	Dwelling, Two Unit		NP	NP	
	Dwelling, Multi-Unit		NP	NP	
	Dwelling, Live / Work		NP	NP	
	Manufactured Home Community		NP	NP	
Residential Care	All Types		NP	NP	
Congregate Living	All Types	NP	NP		
<b>CIVIC, PUBLIC &amp; INSTITUTIONAL PRIMARY USE CLASSIFICATION</b>					
Basic Utilities	Utility, Major Impact* <ul style="list-style-type: none"> <li>• <del>Vehicle: .5 / 1,000 s.f. GFA</del></li> <li>• <del>Bicycle: No requirement</del></li> </ul>	See Section 9.3.4.1	L-ZPSE	L-ZPSE	§ 11.3.1
	Utility, Minor Impact* <ul style="list-style-type: none"> <li>• <del>Vehicle: .5 / 1,000 s.f. GFA</del></li> <li>• <del>Bicycle: No requirement</del></li> </ul>		L-ZP	NP	§ 11.3.2
Community/ Public Services	Community Center* <ul style="list-style-type: none"> <li>• <del>Vehicle: .5 / 1,000 s.f. GFA</del></li> <li>• <del>Bicycle: 1 / 10,000 s.f. GFA (0/100)</del></li> </ul>		L-ZP	NP	§ 11.3.3
	Day Care Center <ul style="list-style-type: none"> <li>• <del>Vehicle: 1 / 1,000 s.f. GFA</del></li> <li>• <del>Bicycle: 1 / 10,000 s.f. GFA (0/100)</del></li> </ul>		P-ZP	NP	
	Postal Facility, Neighborhood		NP	NP	
	Postal Processing Center		NP	NP	
	Public Safety Facility <ul style="list-style-type: none"> <li>• <del>Vehicle: 1 / 1,000 s.f. GFA</del></li> <li>• <del>Bicycle: 1 / 10,000 s.f. GFA (0/100)</del></li> </ul>		P-ZP	NP	
	Hospital		NP	NP	
Correctional Institution	NP	NP			

KEY: \* = Need Not be Enclosed P = Permitted Use without Limitations L = Permitted Use with Limitations NP = Not Permitted Use  
 ZP = Zoning Permit Review ZPIN = Subject to Zoning Permit Review with Informational Notice  
 ZPSE = Subject to Zoning Permit with Special Exception Review When no ZP, ZPIN, ZPSE listed = No Zoning Permit required

USE CATEGORY	SPECIFIC USE TYPE <ul style="list-style-type: none"> <li>• <del>Vehicle Parking Requirement -# of spaces per unit of measurement</del></li> <li>• <del>Bicycle Parking Requirement -# of spaces per unit of measurement (% required spaces in indoor facility/% required spaces in fixed facility)</del></li> </ul>				APPLICABLE USE LIMITATIONS
		OS-A	OS-B	OS-C	
Cultural/Special Purpose/Public Parks & Open Space	Cemetery* • <del>No Parking Requirements</del>	See Section 9.3.4.1	L-ZP	NP	§11.3.6
	Library • <del>Vehicle: 1/1,000 s.f. GFA</del> • <del>Bicycle: 1/10,000 s.f. GFA (0/100)</del>		L-ZP	NP	§11.3.7
	Museum • <del>Vehicle: 1/1,000 s.f. GFA</del> • <del>Bicycle: 1/10,000 s.f. GFA (0/100)</del>		L-ZP	NP	§11.3.7
	City Park* • <del>No Parking Requirements</del>		L-ZP	NP	NP
	Open Space - Conservation* • <del>No Parking Requirements</del>		P-ZP	P-ZP	
Education	Elementary or Secondary School • <del>Vehicle: 1/1,000 s.f. GFA</del> • <del>Bicycle: 1/10,000 s.f. GFA (0/100)</del>	See Section 9.3.4.1	L-ZP	NP	§11.3.8
	University or College		NP	NP	§11.3.8
	Vocational or Professional School		NP	NP	§11.3.8
Public and Religious Assembly	All Types • <del>Vehicle: 0.5/1,000 s.f. GFA</del> • <del>Bicycle: No requirement</del>		P-ZP	NP	

KEY: \* = Need Not be Enclosed P = Permitted Use without Limitations L = Permitted Use with Limitations NP = Not Permitted Use  
ZP = Zoning Permit Review ZPIN = Subject to Zoning Permit Review with Informational Notice  
ZPSE = Subject to Zoning Permit with Special Exception Review When no ZP, ZPIN, ZPSE listed = No Zoning Permit required

USE CATEGORY	SPECIFIC USE TYPE <i>• Vehicle Parking Requirement - # of spaces per unit of measurement</i> <i>• Bicycle Parking Requirement - # of spaces per unit of measurement (% required spaces in indoor facility / % required spaces in fixed facility)</i>				APPLICABLE USE LIMITATIONS
		OS-A	OS-B	OS-C	
<b>COMMERCIAL SALES, SERVICES, &amp; REPAIR PRIMARY USE CLASSIFICATION</b>					
Adult Business	All Types	See Section 9.3.4.1	NP	NP	See Section 9.4.4, Use Overlay Districts, for adult business use allowance in the UO-1 District.
Arts, Recreation & Entertainment	Arts, Recreation and Entertainment Services, Indoor <i>• Vehicle - Artist Studio: 0.3/1,000 s.f. GFA</i> <i>• Vehicle - All Others: 2.5/1,000 s.f. GFA</i> <i>• Bicycle: 1/10,000 s.f. GFA (60/40)</i>		L-ZP	NP	\$11.4.1
	Arts, Recreation and Entertainment Services, Outdoor* <i>• Vehicle: 2.5/1,000 s.f. GFA</i> <i>• Bicycle: 1/10,000 s.f. GFA (60/40)</i>		L-ZPSE	NP	\$11.4.1; \$11.4.3
	Event Space with Alternate Parking and Loading* <i>• Vehicle: No requirement</i> <i>• Bicycle: No requirement</i>		NP	NP	
	Sports and/or Entertainment Arena or Stadium* <i>• Vehicle: 1/1,000 s.f. GFA</i> <i>• Bicycle: 1/10,000 s.f. GFA (0/100)</i>		L-ZPSE	NP	\$11.4.5
Nonresidential Uses in Existing Business Structures In Residential Zones			Not Applicable		
Parking of Vehicles	Parking, Garage <i>• No Parking Requirements</i>		P-ZP	NP	
	Parking, Surface*		NP	NP	
Eating & Drinking Establishments	All Types	NP	NP		

KEY: \* = Need Not be Enclosed P = Permitted Use without Limitations L = Permitted Use with Limitations NP = Not Permitted Use  
 ZP = Zoning Permit Review ZPIN = Subject to Zoning Permit Review with Informational Notice  
 ZPSE = Subject to Zoning Permit with Special Exception Review When no ZP, ZPIN, ZPSE listed = No Zoning Permit required

USE CATEGORY	SPECIFIC USE TYPE <i>• Vehicle Parking Requirement -# of spaces per unit of measurement • Bicycle Parking Requirement -# of spaces per unit of measurement (% required spaces in indoor facility, % required spaces in fixed facility)</i>				APPLICABLE USE LIMITATIONS
		OS-A	OS-B	OS-C	
Lodging Accommodations	Bed and Breakfast Lodging	See Section 9.3.4.1	NP	NP	
	Lodging Accommodations, All Others		NP	NP	
Office	Dental / Medical Office or Clinic		NP	NP	
	Office, All Others		NP	NP	
Retail Sales, Service & Repair (Not Including Vehicle or Equipment Sales, Service & Repair)	Animal Sales and Services, Household Pets Only		NP	NP	
	Animal Sales and Services, All Others		NP	NP	
	Food Sales or Market		NP	NP	
	Pawn Shop		NP	NP	
	Retail Sales, Service & Repair -- Outdoor*		NP	NP	
	Retail Sales, Service & Repair - Firearms Sales		NP	NP	
	Retail Sales, Service & Repair, All Others		NP	NP	
Vehicle / Equipment Sales, Rentals, Service & Repair	Automobile Emissions Inspection Facility		NP	NP	
	Automobile Services, Light		NP	NP	
	Automobile Services, Heavy		NP	NP	
	Automobile / Motorcycle / Light Truck Sales, Rentals, Leasing; Pawn Lot or Vehicle Auctioneer*		NP	NP	
	Heavy Vehicle/ Equipment Sales, Rentals & Service*	NP	NP		



KEY: \* = Need Not be Enclosed P = Permitted Use without Limitations L = Permitted Use with Limitations NP = Not Permitted Use  
ZP = Zoning Permit Review ZPIN = Subject to Zoning Permit Review with Informational Notice  
ZPSE = Subject to Zoning Permit with Special Exception Review When no ZP, ZPIN, ZPSE listed = No Zoning Permit required

USE CATEGORY	SPECIFIC USE TYPE <del>• Vehicle Parking Requirement -# of spaces per unit of measurement</del> <del>• Bicycle Parking Requirement -# of spaces per unit of measurement (% required spaces in indoor facility/% required spaces in fixed facility)</del>	APPLICABLE USE LIMITATIONS			
		OS-A	OS-B	OS-C	
<b>INDUSTRIAL, MANUFACTURING &amp; WHOLESALE PRIMARY USE CLASSIFICATION</b>					
Communications and Information	Antennas Not Attached to a Tower* <del>• No Parking Requirements</del>	See Section 9.3.4.1	L-ZP	NP	§ 11.5.2
	Communication Services		NP	NP	
	Telecommunications Towers* <del>• No Parking Requirements</del>		L-ZP/ ZPIN/ ZPSE	NP	§11.5.2
	Telecommunications Tower - Alternative Structure <del>• No Parking Requirements</del>		L-ZP/L- ZPIN	NP	§11.5.2
	Telecommunication Facilities -- All Others* <del>• No Parking Requirements</del>		L-ZPIN	NP	§11.5.2
Industrial Services	Contractors, Special Trade - General		NP	NP	
	Contractors, Special Trade - Heavy/Contractor Yard*		NP	NP	
	Food Preparation and Sales, Commercial		NP	NP	
	Laboratory, Research, Development and Technological Services		NP	NP	
	Service/Repair, Commercial		NP	NP	
Manufacturing and Production	Manufacturing, Fabrication & Assembly -- Custom	NP	NP		
	Manufacturing, Fabrication & Assembly -- General	NP	NP		
	Manufacturing, Fabrication & Assembly -- Heavy	NP	NP		
Mining & Extraction and Energy Producing Systems	Oil, Gas -- Production, Drilling*	NP	NP		
	Sand or Gravel Quarry*	NP	NP		
	Wind Energy Conversion Systems* <del>• No Parking Requirements</del>	L-ZP	NP	§11.5.13	
Transportation Facilities	Airport*	NP	NP		
	Helipad, Helistop, Heliport*	NP	NP		
	Railroad Facilities*	NP	NP		
	Railway Right-of-Way* <del>• No Parking Requirements</del>	P-ZP	P-ZP		
	Terminal, Station or and Service Facility for Passenger Transit System	NP	NP		
	Terminal, Freight, Air Courier Services	NP	NP		

KEY: \* = Need Not be Enclosed P = Permitted Use without Limitations L = Permitted Use with Limitations NP = Not Permitted Use  
ZP = Zoning Permit Review ZPIN = Subject to Zoning Permit Review with Informational Notice  
ZPSE = Subject to Zoning Permit with Special Exception Review When no ZP, ZPIN, ZPSE listed = No Zoning Permit required

USE CATEGORY	SPECIFIC USE TYPE <i>• Vehicle Parking Requirement -# of spaces per unit of measurement • Bicycle Parking Requirement -# of spaces per unit of measurement (% required spaces in indoor facility/% required spaces in fixed facility)</i>				APPLICABLE USE LIMITATIONS
		OS-A	OS-B	OS-C	
Waste Related Services	Automobile Parts Recycling Business	See Section 9.3.4.1	NP	NP	
	Junkyard*		NP	NP	
	Recycling Center		NP	NP	
	Recycling Collection Station		NP	NP	
	Recycling Plant, Scrap Processor		NP	NP	
	Solid Waste Facility		NP	NP	
Wholesale, Storage, Warehouse & Distribution	Automobile Towing Service Storage Yard*		NP	NP	
	Mini-storage Facility		NP	NP	
	Vehicle Storage, Commercial*		NP	NP	
	Wholesale Trade or Storage, General		NP	NP	
	Wholesale Trade or Storage, Light		NP	NP	
<b>AGRICULTURE PRIMARY USE CLASSIFICATION</b>					
Agriculture	Aquaculture* <i>• Vehicle: 0.5/1,000 s.f. GFA • Bicycle: No requirement</i>	See Section 9.3.4.1	L-ZP	NP	\$11.6.1
	Garden, Urban* <i>• Vehicle: 0.5/1,000 s.f. GFA • Bicycle: No Requirement</i>		L-ZP	NP	\$11.6.2
	Husbandry, Animal* <i>• Vehicle: 0.5/1,000 s.f. GFA • Bicycle: No Requirement</i>		L-ZP	NP	\$11.6.3
	Husbandry, Plant* <i>• Vehicle: 0.5/1,000 s.f. GFA • Bicycle: No Requirement</i>		L-ZP	NP	\$11.6.4
	Plant Nursery* <i>• Vehicle: 0.5/1,000 s.f. GFA • Bicycle: No Requirement</i>		L-ZP	NP	\$11.6.5

KEY: \* = Need Not be Enclosed P = Permitted Use without Limitations L = Permitted Use with Limitations NP = Not Permitted Use  
 ZP = Zoning Permit Review ZPIN = Subject to Zoning Permit Review with Informational Notice  
 ZPSE = Subject to Zoning Permit with Special Exception Review When no ZP, ZPIN, ZPSE listed = No Zoning Permit required

USE CATEGORY	SPECIFIC USE TYPE <ul style="list-style-type: none"> <li>• <del>Vehicle Parking Requirement -# of spaces per unit of measurement</del></li> <li>• <del>Bicycle Parking Requirement -# of spaces per unit of measurement (% required spaces in indoor facility/% required spaces in fixed facility)</del></li> </ul>				APPLICABLE USE LIMITATIONS	
		OS-A	OS-B	OS-C		
<b>ACCESSORY TO PRIMARY RESIDENTIAL USES USE CLASSIFICATION</b>						
Accessory to Primary Residential Uses  ( <del>Parking is Not Required for Accessory Uses Unless Specifically Stated in this Table or in an Applicable Use Limitation</del> )	Unlisted Accessory Uses	See Section 9.3.4.1		NP	NP	
	Accessory Dwelling Unit			NP	NP	
	Domestic Employee			NP	NP	
	Garden*			NP	NP	
	Keeping of Household Animals*			NP	NP	
	Keeping and Off-Street Parking of Vehicles, Motorcycles, Trailers & Recreational Vehicles*			NP	NP	
	Kennel or Exercise Run*			NP	NP	
	Limited Commercial Sales, Services Accessory to Multi-Unit Dwelling Use			NP	NP	
	Outdoor Storage, Residential*			NP	NP	
	Second Kitchen Accessory to Single Unit Dwelling Use			NP	NP	
	Short-term Rental			NP	NP	
	Vehicle Storage, Repair and Maintenance*			NP	NP	
	Wind Energy Conversion Systems*			Not Applicable - See Permitted Primary Uses		
Yard or Garage Sales*		NP	NP			
<b>HOME OCCUPATIONS ACCESSORY TO PRIMARY RESIDENTIAL USES USE CLASSIFICATION</b>						
Home Occupations	Child Care Home, Large	See Section 9.3.4.1		NP	NP	
	All Other Types			NP	NP	
	Unlisted Home Occupations			NP	NP	

KEY: \* = Need Not be Enclosed P = Permitted Use without Limitations L = Permitted Use with Limitations NP = Not Permitted Use  
 ZP = Zoning Permit Review ZPIN = Subject to Zoning Permit Review with Informational Notice  
 ZPSE = Subject to Zoning Permit with Special Exception Review When no ZP, ZPIN, ZPSE listed = No Zoning Permit required

USE CATEGORY	SPECIFIC USE TYPE <i>• Vehicle Parking Requirement -# of spaces per unit of measurement • Bicycle Parking Requirement -# of spaces per unit of measurement (% required spaces in indoor facility/% required spaces in fixed facility)</i>	APPLICABLE USE LIMITATIONS			
		OS-A	OS-B	OS-C	
<b>ACCESSORY TO PRIMARY NONRESIDENTIAL USES USE CLASSIFICATION</b>					
Accessory to Primary Nonresidential Uses	Unlisted Accessory Uses	See Section 9.3.4.1	L - Applicable to all Zone Districts		\$11.7; §11.10.1
	Amusement Devices Accessory to Eating/ Drinking Establishments, College/University and Theater Uses		NP	NP	
	Automobile Rental Services Accessory to Certain Retail Uses*		NP	NP	
	Book or gift store; media recording and production facilities accessory to public libraries, museums, places of religious assembly, colleges or universities		L	NP	§ 11.7
	Car Wash Bay Accessory to Automobile Services		NP	NP	
	College accessory to a Place for Religious Assembly		NP	NP	
	Conference Facilities Accessory to Hotel Use		NP	NP	
	Drive Through Facility Accessory to Eating/ Drinking Establishments and to Retail Sales, Service, and Repair Uses*		NP	NP	
	Emergency Vehicle Access Point		NP	NP	
	Garden*		L	L	\$11.7; §11.10.10
	Keeping of Animals		L/L-ZP/ L-ZPIN	L/L-ZP/ L-ZPIN	\$11.7; §11.10.11
	Limited Commercial Sales, Services		L	L	\$11.7; §11.10.12
	Nonresidential Uses in Existing Business Structures In Residential Zones - Accessory Uses		Not Applicable		
	Occasional Sales, Services Accessory to Primary Places of Religious Assembly or Primary Uses Operated by Nonprofit Organizations*		L	NP	\$11.7; §11.10.12
	Outdoor Gathering Area*		L/L-ZP	NP	\$11.7; §11.10.14
	Outdoor Entertainment Accessory to an Eating/Drinking Establishment Use*		NP	NP	
	Outdoor Retail Sale and Display*		NP	NP	
	Outdoor Storage, General*		NP	NP	
	Outdoor Storage, Limited*		NP	NP	
	Rental or Sales of Adult Material Accessory to a Permitted Bookstore Retail Sales Use		NP	NP	
Retail Food Establishment, Mobile (Food Truck)*	L-ZP	NP	\$11.7; §11.10.20		

KEY: \* = Need Not be Enclosed P = Permitted Use without Limitations L = Permitted Use with Limitations NP = Not Permitted Use  
 ZP = Zoning Permit Review ZPIN = Subject to Zoning Permit Review with Informational Notice  
 ZPSE = Subject to Zoning Permit with Special Exception Review When no ZP, ZPIN, ZPSE listed = No Zoning Permit required

USE CATEGORY	SPECIFIC USE TYPE <ul style="list-style-type: none"> <li>• <del>Vehicle Parking Requirement - # of spaces per unit of measurement</del></li> <li>• <del>Bicycle Parking Requirement - # of spaces per unit of measurement (% required spaces in indoor facility / % required spaces in fixed facility)</del></li> </ul>				APPLICABLE USE LIMITATIONS
		OS-A	OS-B	OS-C	
<b>TEMPORARY USE CLASSIFICATION</b>					
Temporary Uses	Unlisted Temporary Uses	See Section 9.3.4.1	L-ZP	L-ZP	\$11.11.1
	Ambulance Service - Temporary		NP Not Applicable - See Permitted Primary Uses	NP	
	Amusement / Entertainment - Temporary*		L-ZP	NP	\$11.11.3
	Bazaar, Carnival, Circus or Special Event*		L-ZP	NP	\$11.11.4
	Building or yard for construction materials*		L-ZP	NP	\$11.11.5
	Concrete, Asphalt, and Rock Crushing Facility*		L-ZP	NP	\$11.11.6
	Fence for Demolition or Construction Work		L-ZP	NP	\$11.11.7
	Health Care Center		NP	NP	
	Noncommercial Concrete Batching Plant*		L-ZP	NP	\$11.11.9
	Outdoor Retail Sales - Pedestrian / Transit Mall*		NP	NP	
	Outdoor Retail Sales*		NP	NP	
	Outdoor Sales, Seasonal*		L-ZP	NP	\$11.11.12
	Parking Lot Designated for a Special Event*		L-ZP	NP	\$11.11.13
	Retail Food Establishment, Mobile (Food Truck)*		L/L-ZP	NP	\$11.11.14
	Temporary Construction Office		L-ZP	NP	\$11.11.15
	Temporary Office - Real Estate Sales		NP	NP	
	Temporary Managed Community*		NP	NP	
	Tent for Religious Services		L-ZP	NP	\$11.11.18

**B. Limitation on Permit Issuance**

No zoning permit for development or a use within a Use Overlay District shall be issued by the City unless the development or use meets the standards set forth in this Section, as applicable.

**9.4.4.6 Adult Use Overlay District (UO-1)**

**A. Creation**

There is hereby created a Use Overlay District designated as the Adult Use Overlay District.

**B. Allowance for Adult Business Uses**

Notwithstanding the limitations applicable in the underlying zone district, adult business uses shall be permitted in this overlay zone district. See Section 11.12.4.1.A for the definition of “adult business use.”

**C. Distance and Spacing Requirements**

All Adult Business uses shall comply with the following distance and spacing requirements, shown in the table below. All distance and spacing requirements shall be measured according to the rule of measurement found in Section 13.1.11.

ADULT BUSINESS OR OTHER RESTRICTED USE	DISTANCE OR SPACING REQUIREMENT
Adult Amusement or Entertainment Adult Bookstore Adult Photo Studio Adult Theater Eating place with adult amusement or entertainment Sexually Oriented Commercial Enterprise	No adult business use listed in this table row shall be established within 500 feet of one or more of the following zone districts or uses (see related definitions in subsection D below): <ul style="list-style-type: none"> <li>• All Residential Zone Districts</li> <li>• Dwelling Use, Single-Unit</li> <li>• Dwelling Use, Multi-Unit</li> <li>• Dwelling Use, Two-Unit</li> <li>• Religious Assembly</li> <li>• Elementary or Secondary School</li> <li>• Arts Education Center</li> <li>• Learning Center</li> <li>• Day Care Center</li> <li>• Amusement or Special Interest Park</li> <li>• Children’s Indoor Play Center</li> </ul>
Adult Amusement or Entertainment Adult Bookstore Adult Photo Studio Adult Theater Amusement Center Eating place with adult amusement or entertainment Sexually Oriented Commercial Enterprise	Not more than 2 of the uses listed in this table row shall be established within 1,000 feet of each other

**D. Use Definitions for Purposes of Distance/Spacing Requirements**

For purposes of applying the distance and spacing requirements for adult business uses stated in this Section, the uses listed below shall be defined as follows:

1. “Arts education center” solely for purposes of adult use separation requirements, shall mean a place where instruction is regularly provided to persons less than 18 years of age

in the fields of painting, drawing, sculpture, etching, craft work, fine arts, dance, drama, photography, music, martial arts, or other similar fields of art.

2. “Amusement center” shall mean a commercial establishment having four or more amusement devices.
3. “Amusement/special interest park” shall mean a complex with both indoor and outdoor entertainment, eating places/restaurants and/or limited retail uses, open to the public upon payment of a fee or admission charge.
4. “Children’s indoor play center” shall mean a commercial establishment providing active play facilities for children generally under the age of 12 years old. Such facilities shall consist generally of muscle-powered equipment. No pinball, foosball, video or electronic games or similar equipment shall be permitted.
5. “Learning center” shall mean a commercial business that regularly provides on site, specialized or intensive educational services or tutoring to persons less than 18 years of age.

**E. Parking Requirement**

NEIGHBORHOOD CONTEXT	VEHICLE PARKING Vehicle Parking Requirement: # of spaces per unit of measurement	BICYCLE PARKING Bicycle Parking Requirement: # of spaces per unit of measurement (% required spaces in indoor facility / % required spaces in fixed facility)
Suburban (S-)	2.5 / 1,000 ft <sup>2</sup> GFA MS only: 2 / 1,000 ft <sup>2</sup> GFA	1 / 20,000 ft <sup>2</sup> GFA (20/80)
Urban Edge (E-)	2.5 / 1,000 ft <sup>2</sup> GFA MS only: 2 / 1,000 ft <sup>2</sup> GFA	1 / 20,000 ft <sup>2</sup> GFA (20/80)
Urban (U-)	2.5 / 1,000 ft <sup>2</sup> GFA MS only: 2 / 1,000 ft <sup>2</sup> GFA	1 / 10,000 ft <sup>2</sup> GFA (20/80)
General Urban (G-)	1.875 / 1,000 ft <sup>2</sup> GFA	1 / 10,000 ft <sup>2</sup> GFA (20/80)
Urban Center (C-)	1.25 / 1,000 ft <sup>2</sup> GFA	1 / 7,500 ft <sup>2</sup> GFA (20/80)
Downtown (D-) D-GT & D-AS only	1.25 / 1,000 ft <sup>2</sup> GFA	1 / 7,500 ft <sup>2</sup> GFA (20/80)
Industrial (I-)	2.5 / 1,000 ft <sup>2</sup> GFA	1 / 20,000 ft <sup>2</sup> GFA (20/80)
Campus (CMP-)	1.25 / 1,000 ft <sup>2</sup> GFA	1 / 7,500 ft <sup>2</sup> GFA (20/80)
Master Planned (M-)	1.875 / 1,000 ft <sup>2</sup> GFA	1 / 10,000 ft <sup>2</sup> GFA (20/80)

**9.4.4.7 Billboard Use Overlay District (UO-2)**

**A. Creation**

There is hereby created a use overlay district designated as the Billboard Use Overlay District.

**B. Allowance for Billboards**

Notwithstanding the limitations applicable in the underlying zone district, “outdoor general advertising device” signs, also known as “billboards”, shall be permitted in this overlay zone district. See Article 13 for the definition of “outdoor general advertising device.”

**C. Applicable Use Limitations**

All outdoor general advertising device uses in this Use Overlay District shall comply with the sign standards and limitations applicable to “outdoor general advertising devices” stated in Division 10.10, Signs, and Section 10.10.21, Outdoor General Advertising Devices in the

Billboard Use Overlay District, including but not limited to minimum separation and distance requirements.

#### 9.4.4.8 Historic Structure Use Overlay District (UO-3)

##### A. Creation

There is hereby created a use overlay district designated as the Historic Structure Use Overlay District.

##### B. Intent

To encourage preservation, protection, adaptive use, and enhancement of Historic Structures, or otherwise to promote the Landmark Preservation purposes as stated in DRMC Sec. 30-1.

##### C. Establishment

The Historic Structure Use Overlay District may only be established in conjunction with an underlying Residential Zone District.

##### D. Allowance for Certain Commercial Uses

Notwithstanding the limitations applicable in the underlying zone district, the following commercial uses shall be permitted in this overlay zone district:

1. Office, not including dental/medical office or clinic
2. Art studio
3. Bed and breakfast lodging

##### E. Applicable Use Limitations - Office and Art Studio Uses

Office (not including dental/medical office or clinic) or art studio uses in this overlay zone district are permitted only in an Historic Structure and subject to compliance with the following conditions:

1. The applicant for establishment of the office or art studio use is the owner of record of the subject structure.
2. The subject structure was legally erected.
3. The subject structure contains a minimum of 5,000 square feet of gross floor area.
4. For any modifications to the structure that require landmark approval, the modification shall have been reviewed and approved by the Landmark Preservation Commission before submittal for zoning approval.
5. All uses in the structure involved shall comply with the limitations on external effects applicable to uses in the district in which the structure is located.
6. All uses operated in the structure involved shall comply with this Code's ~~off-street parking and~~ off-street loading requirements for each such use in the MS-2 zone district; provided, however, that upon proof that full compliance could not be achieved, the Zoning Administrator may waive so much of those requirements as are impossible of fulfillment according to the Administrative Adjustment procedures in Section 12.4.5. ~~The parking exemption for Historic Structures in Section 10.4.5.1.C of this Code shall not be applicable to office and art studio uses permitted in an UO-3 overlay zone district.~~
7. All uses permitted in the structure shall comply with limitations on permitted signs applicable to uses in the MS-2x zone district.



#### F. Applicable Use Limitations - Bed and Breakfast Lodging

Bed and breakfast lodging uses in this overlay zone district are permitted only in a Historic Structure, as defined in Article 13, Rules of Measurement and Definitions, and subject to compliance with the following conditions:

1. The applicant for establishment of the bed and breakfast lodging use is the owner of record and uses the structure as his/her principal residence.
2. The subject structure contains no more than 10 guest rooms or suites and that the use of the dining room shall be restricted to use by overnight guests, employees, the owner's family and/or nonpaying guests.
3. ~~Off-street parking shall be provided at a ratio of 1 parking space for each of the following: Each guest room or suite, each nonresident employee and the owner. The Zoning Administrator may reduce this ratio by up to 20 percent of the requirement according to the Administrative Adjustment procedure in Section 12.4.5, Administrative Adjustment. The parking exemption for Historic Structures in Section 10.4.5.1.C of this Code shall not be applicable to bed and breakfast lodging uses permitted in an UO-3 overlay zone district.~~
4. No other such lodging is located within 500 feet of the proposed use as measured along the same face block from zone lot line to zone lot line.
5. The structure contains a minimum of 1,000 square feet of gross floor area and no guest room or suite contains less than 100 square feet of floor area.
6. The lodging shall provide breakfast as part of the room price.
7. The interior and exterior of the structure shall be maintained in a manner that reflects the original architectural character of the building, and the property shall be landscaped in a manner that protects the appearance and value of surrounding properties and neighborhoods and improves environmental conditions, thereby promoting the general welfare. The landscaping shall be Continuously Maintained which includes necessary watering, weeding, pruning, pest control and replacement of dead or diseased plant material. Replacement shall occur in the next planting season; but, in any event, replacement time shall not exceed one year.
8. The sign regulations of Division 10.10, Signs, shall apply; provided, however, the maximum sign area permitted on any one street front shall not exceed 10 square feet. The maximum height of any ground sign shall be 4 feet.
9. Related retail sales may be conducted within the structure; however, the floor area allocated to this retail use shall not exceed 10 percent of the gross floor area of the structure. Access to this retail area shall be limited to use by overnight guests only.
10. No social activities, such as weddings, receptions, private parties or similar events, will be permitted unless at least 90 percent of the participants are overnight guests.

### SECTION 9.4.5 DESIGN OVERLAY DISTRICTS (DO-)

#### 9.4.5.1 General Purpose

Design Overlay Districts are intended to serve one or more of the following purposes:

- A. To implement land use and urban design recommendations and standards set forth in neighborhood or small area plans, which plans have been adopted as part of the Comprehensive Plan;
- B. To reinforce the desired character for newly developing or redeveloping areas.

**12. Submittal Requirements**

An applicant seeking approval of a Supplemental Plan shall submit the following items to Community Planning and Development:

- a. Information as required by the District Plan, and
- b. Other items as may be identified by the Zoning Administrator as reasonably necessary to approve such Supplemental Plan consistent with the criterion stated in Section 9.4.5.10.W.7.

**13. Review**

The Zoning Administrator will review information received in the applicant's submittal and, within 45 days after the submittal of a complete application for a Supplemental Plan, make a final decision to approve, approve with conditions or deny such plan unless the applicant agrees in writing to an extension of time.

**14. Notice to Others**

- a. The Zoning Administrator shall send notice of the Supplemental Plan to:
  - i. Neighborhood organizations which are registered according to the provisions of D.R.M.C. Section 12-94 and whose boundaries include property within, or within 200 feet of, the DO-6 zone district,
  - ii. Each City Council member representing a district within the DO-6 zone district or within 200 feet of the DO-6 zone district, and
  - iii. The at-large City Council members.
- b. Notices required by this Section 9.4.5.10.V.6. shall be sent at least 14 days prior to the Zoning Administrator's decision to approve, approve with conditions or deny such plan.

**15. Criterion for Review**

The Zoning Administrator may approve an application for a Supplemental Plan if the Supplemental Plan is consistent with the provisions of the District Plan.

**16. Appeals**

Any decision of the Zoning Administrator under this Section 9.4.5.10.W may be appealed to the Planning Board. Thereafter, the Planning Board's decision may be appealed to the District Court.

**17. Effect of Approval of a Supplemental Plan**

Upon the Zoning Administrator's approval of a Supplemental Plan, such Supplemental Plan shall be deemed an amendment to, and shall be deemed to have become part of, the District Plan. An approved Supplemental Plan shall be incorporated into the next Amended District Sign Plan, at which time the Supplemental Plan shall expire.

**9.4.5.11 River North Design Overlay District (DO-7)**

**A. Creation**

There is hereby created a design overlay district designated as the River North (RiNo) Design Overlay District (DO-7).

**B. General Purpose of Overlay District**

1. Implement adopted plans; and
2. Promote creative, high-quality, design in the general area covered by the adopted 38th and Blake Station Area Height Amendments and the RiNo Business Improvement District;
3. Provide flexibility to support the diverse design traditions of RiNo;
4. Activate the South Platte River frontage to promote the river as a neighborhood asset;
5. Maintain human scale and access to daylight as heights and densities increase throughout the district;

TRANSPARENCY ALTERNATIVES			
ZONE LOT LINE DESIGNATION	PERMANENT OUTDOOR GATHERING AREAS (MAX)	PERMANENT ART (MAX)	COMBINATION OF ALTERNATIVES (MAX)
Primary Street	0%	50%	80%
Primary Street B	0%	50%	80%
Side Street	0%	50%	80%

**H. Vehicle Parking Exception for Transit Oriented Development in the DO-7 District**

**1. Intent**

To promote multi-modal transportation options near major transit investments and provide flexibility for development with reduced automobile orientation.

**2. Applicability**

- a. The vehicle parking exception set forth below shall apply all to all uses located within this DO-7 district that are also located within 1/2 mile of the outer boundary of the Rail Transit Station Platform at the 38th and Blake commuter rail station.
- b. All distance and spacing requirements shall be measured according to the rule of measurement found in Section 13.1.11, Measurement of Separation or Distance.

**3. Exemption Allowed**

- a. Uses in the area described by Section 9.4.5.11.H.2.a shall be exempt from providing the minimum amount of vehicle parking otherwise required by this Code.
- b. Minimum bicycle parking requirements set forth in the Underlying Zone District shall apply.

**4. Relationship to Maximum Vehicle Surface Parking for Transit Oriented Development**

Where Section 10.4.4.4, Maximum Vehicle Surface Parking for Transit Oriented Development, applies, maximum parking standards shall apply, based on the minimum amount of parking set forth in the Underlying Zone District for such use or structure absent any exemption or reduction.

2. Minimize noise impacts of the airport on residential or sensitive land uses in the DIA Influence Area.

**C. Manufactured Home Community Zone District (MHC)**

The Manufactured Home Community zone district encourages the continued use and improvement of Denver's existing manufactured home communities. This zone district is intended to be applied only to manufactured home communities existing and established before July 1, 2024. Accordingly, the intent of the MHC zone district is to:

1. Maintain the use and character of these communities as an important source of affordable housing.
2. Discourage redevelopment of these communities to minimize displacement of vulnerable residents.
3. Support the long-term viability of these communities by reducing zoning barriers to obtaining financing for ongoing maintenance and improvement.

## **SECTION 9.5.2 DENVER INTERNATIONAL AIRPORT ZONE DISTRICT (DIA)**

### **9.5.2.1 Building Forms**

The Denver Manager of Aviation shall determine all applicable building form standards in the DIA zone district.

### **9.5.2.2 Design Standards**

**A. Signage**

Design and development standards governing signage in the DIA zone district shall be determined by the Denver Manager of Aviation, except that in the Peña Station Next Design Overlay District (DO-6), Section 9.4.5.10 and Division 10.10 Signs shall apply.

**B. All Other Design Standards**

All other design and development standards governing uses and structures in the DIA zone district, including but not limited to landscaping and parking, shall be determined by the Denver Manager of Aviation.

### **9.5.2.3 Permitted Uses in the DIA Zone District**

See Section 9.5.5, Uses ~~and Required Minimum Parking~~.

## **SECTION 9.5.3 DIA INFLUENCE AREA OVERLAY ZONE (AIO-)**

### **9.5.3.1 DIA Influence Area**

The DIA Influence Area is defined as the land area located north of 56<sup>th</sup> Avenue in the City and County of Denver's DIA statistical neighborhood, as shown in Figure 9.5-1, and on the Official Map.

## SECTION 9.5.5 MANUFACTURED HOME COMMUNITY ZONE DISTRICT

### 9.5.5.1 Design Standards General Intent

Implement the zone district’s intent and purpose by encouraging the continued use and improvement of Denver’s existing Manufactured Home Communities.

### 9.5.5.2 Specific Building Form Intent

#### A. Height

1. Maintain the low-scale building height of existing manufactured home communities.
2. Allow for a limited increase in building height to add livable area within smaller building footprints when Dwelling Units are replaced in a manufactured home community.

#### B. Siting

1. Site buildings to be consistent with the existing community character.
2. Allow for siting flexibility to facilitate the replacement of Dwelling Units in a manufactured home community.

#### C. Design Elements

Maintain the scale, density, and affordability of existing manufactured home communities by limiting the maximum building footprint.

### 9.5.5.3 Primary Building Form Standards

#### A. Applicability

All development, except detached accessory structures, in the Manufactured Home Community zone district.

#### B. District Specific Standards Summary

The only primary building form allowed in the MHC zone district is the Manufactured Home. There is no maximum number of structures allowed per Zone Lot, which is stated in more detail in Section 1.2.3.5, Number of Uses and Structures Allowed per Zone Lot.

See also Division 1.4, Building Form Standards - General Provisions, for additional standards related to initial assignment of building form standards to new and existing structures and for rules governing combining or changing building forms.

Manufactured Home Community Zone District	Max Number of Primary Structures per Zone Lot	Building Forms
		Manufactured Home
MHC	no maximum	■

■ = Allowed

### 9.5.5.4 District Specific Standards

#### A. Manufactured Home

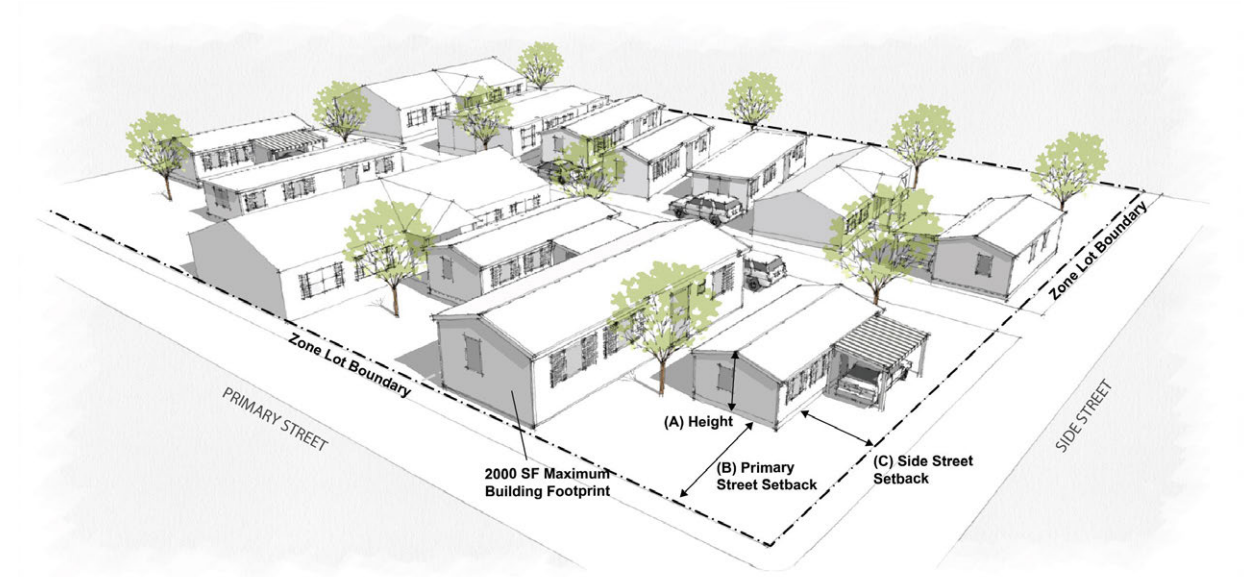

## MANUFACTURED HOME

<b>HEIGHT</b>		MHC
A	Feet (max)	20'

<b>SITING</b>		MHC
<b>SETBACKS</b>		
B	Primary Street (min)	0'
C	Side Street (min)	0'
D	Side Interior (min)	0'
E	Rear (min)	0'
<b>PARKING</b>		
	Surface Parking between building and Primary Street/Side Street	Allowed/Allowed
	Vehicle Access	From Alley or Street
F	<b>DETACHED ACCESSORY STRUCTURES</b>	See Section 9.5.5.7

<b>DESIGN ELEMENTS</b>		MHC
G	Building Footprint (max)	2,000 sf

<b>USES</b>		MHC
		Primary Use shall be limited to Manufactured Home Community See Section 9.5.6, Uses, <del>and Required</del> <del>Minimum Parking</del>

### 9.5.5.5 Detached Accessory Structure Building Form Standards

#### A. Applicability

All detached accessory structures in the Manufactured Home Community zone district.

#### B. General Standards

##### 1. Detached Accessory Structures Allowed

Allowed detached accessory structures include the following:

###### a. Structures, Completely Enclosed:

Examples include sheds, utility buildings, playhouses, garages, guard houses, leasing/property management office, laundry rooms, communal gathering space, storage/maintenance, and other similar Completely Enclosed Structures.

###### b. Structures, Partially Enclosed:

Examples include carports, gazebos, porches, trellises, chicken coops, and other similar Partially Enclosed Structures.

###### c. Structures, Open:

Examples include hot tubs and associated surrounds, decks, balconies, recreational and play facilities, non-commercial barbecues, outside fireplaces, outdoor eating areas, and other similar Open Structures.

###### d. Utilities and Equipment Common and Customary to the Primary Structure and/or Use

Examples include to the following:

i. Radio and Television Receiving Antennas and Support Structures

ii. Permitted accessory radio and television receiving antennas and support structures shall include satellite dishes less than 32 inches in diameter, and one amateur radio sending and receiving antenna and support structures provided for same.

iii. Solar thermal and photo-voltaic energy systems

iv. Ground-mounted mechanical equipment such as air conditioning units and heats pumps

v. Other similar Detached Accessory Structures, Utilities, and Equipment Common and Customary to the Primary Structure and/or Use

###### e. Fences, Walls and Retaining Walls

All accessory fences, walls and retaining walls, including fences and walls used for required screening, shall comply with the fence, wall and screening standards in Division 10.5 instead of this subsection 9.5.5.7.



**f. Detached Accessory Structures Not Listed**

- i. The Zoning Administrator shall determine and impose limitations on accessory structures not otherwise listed as allowed in an applicable Use Table in Article 9, or not otherwise covered by the standards in this subsection 9.5.5.75.
- ii. All such determinations shall be reviewed according to the procedures and review criteria stated in Section 12.4.6, Code Interpretations and Determination of Unlisted Uses. In addition to the criteria stated in Section 12.4.6, the Zoning Administrator shall determine whether a proposed accessory structure is common and customary to the primary structure on the zone lot or to a specific primary use, and if the structure is incidental to the primary structure(s) on the zone lot or to a specific primary use.
- iii. The Zoning Administrator may impose limitations on the proposed accessory structure, which shall be uniform throughout the zone district, and taking into consideration the size of the accessory structure, the total number of structures on the zone lot, and the effect on adjacent property.
- iv. Matters that may be regulated according to this Section shall include the size, area and number of accessory structures, except as specifically permitted or excluded by this subsection 9.5.5.7.

**9.5.5.6 District Specific Standards Summary**

The table below states the building forms allowed in the MHC zone district for detached accessory structures. The table also summarizes the maximum number of structures allowed per Zone Lot, which is stated in more detail in Section 1.2.3.5, Number of Uses and Structures Allowed per Zone Lot.

See also Division 1.4, Building Form Standards - General Provisions, for additional standards related to initial assignment of building form standards to new and existing structures and for rules governing combining or changing building forms.

Manufactured Home Community Zone District	Building Forms		
	Detached Accessory Dwelling Unit	General Detached Structures	Minor Detached Structures
Maximum number of detached accessory structures per Zone Lot		No max*	Option A: No max  Option B: One per primary dwelling
MHC		■	■

■ = Allowed

\*One per dwelling unit for structures with vehicle access doors, See Section 1.2.3.5, Number of Uses and Structures Allowed per Zone Lot.

## SECTION 9.5.6 USES ~~AND REQUIRED MINIMUM PARKING~~

### 9.5.6.1 Applicability

#### A. DIA Zone District

Permitted uses, required minimum parking, number of uses, and any applicable use limitations in the DIA zone district, shall be determined by the Denver Manager of Aviation.

#### B. O-1 Zone District

1. This Section 9.5.5 sets forth the land uses permitted; ~~and the~~ required zoning procedures ~~and the required minimum parking~~ for the O-1 zone district.
2. Uses not listed are prohibited, unless the Zoning Administrator specifically permits the unlisted use according to Section 12.4.6, Code Interpretations and Determination of Unlisted Uses.
3. For number of primary and accessory uses allowed per Zone Lot, see Section 1.2.3.5, Number of Structures and Uses Allowed per Zone Lot.

### 9.5.6.2 Organization

#### A. Organized by Primary, Accessory and Temporary Uses

The Use ~~and Parking~~ Table first presents all primary uses, then all accessory uses, and finally all temporary uses. Primary uses are arranged hierarchically within the table by use classification, category of primary uses, and then by specific use type. Accessory uses are organized by whether such use is accessory to a primary residential use or to a primary nonresidential use. Temporary uses are presented alphabetically ordered in the last division of the table.

#### B. Primary Use Classifications, Categories & Specific Use Types

##### 1. Primary Use Classifications

All primary land uses in the Use ~~and Parking~~ Table are organized into one of the following five general land use classifications:

- a. Residential Uses
- b. Civic, Public & Institutional Uses
- c. Commercial Sales, Service & Repair Uses
- d. Industrial, Manufacturing & Wholesale Uses
- e. Agriculture

**2. Primary Use Categories & Specific Use Types**

Primary uses are further organized into use categories and specific use types listed under each general primary land use classification. The Use ~~and Parking~~ Table is organized into the above five general land use classifications, use categories and specific use types.

**3. Classifications & Categories Are Mutually Exclusive**

The general land use classifications and use categories listed in the Use ~~and Parking~~ Table are intended to be mutually exclusive; that is, a use classified into one use category, such as “lodging accommodations,” cannot be classified in a different use category, such as “congregate living,” unless otherwise expressly allowed by this Code.

**9.5.6.3 Explanation of Table Abbreviations**

**A. General Explanation of Table Cell Entries**

In each of the table cells, the entry will indicate first whether use limitations apply to the specific use, and then separated by a hyphen, the type of zoning review required prior to establishment of the use under this Code. For example, as described in more detail below, a cell entry “L-ZPIN” means, first, the use is subject to use limitations (the “L”), and, second, that the use is subject to zoning permit review with information notice (the “ZPIN”) prior to its establishment.

**B. Permitted, Limited, Not Permitted**

**1. Permitted Use - No Use Limitations Apply (“P”)**

A “P” in a table cell indicates that the use is permitted in the respective zone district, and is not subject to use limitations.

**2. Permitted Use - Subject to Use Limitations (“L”)**

“L” in a table cell indicates the use is permitted in the zone district subject to compliance with the use limitations referenced in the last column of the use table (“Applicable Use Limitations”).

**3. Uses Not Permitted (“NP”)**

“NP” in a table cell indicates that the use is not permitted in the specific zone district.

**C. Zoning Procedure**

**1. Use Subject to Zoning Permit Review (“ZP”)**

“ZP” in a table cell indicates that the use is permitted in the respective zone district only if reviewed and approved according to the requirements in Section 12.4.1, Zoning Permit Review.

**2. Use Subject to Zoning Permit Review with Informational Notice (“ZPIN”)**

“ZPIN” in a table cell indicates that the use is permitted in the respective zone district only if reviewed and approved according to the public notice and procedural requirements in Section 12.4.2, Zoning Permit Review with Informational Notice. Such uses shall comply with any applicable use limitations noted in the last column of the use table (“Applicable Use Limitations”), as well as the review criteria stated in Section 12.4.2, Zoning Permit Review with Informational Notice.

**3. Use Subject to Zoning Permit Review with Community Information Meeting (“ZPCIM”)**

“ZPCIM” in a table cell indicates that the use is permitted in the respective zone district only if reviewed and approved according to the public notice and procedural requirements in Section 12.4.1, Zoning Permit Review. Prior to formal application, an applicant shall schedule a community information meeting and provide public notice of the community information meeting according to Section 12.3.4.6, Community Information Meeting.

- 4. Use Subject to Zoning Permit with Special Exception Review (“ZPSE”)**  
“ZPSE” in a table cell indicates that use is generally appropriate in the neighborhood context and zone district, yet may have the potential for limited impacts on adjacent properties or on the established character of the neighborhood context or zone district. “ZPSE” uses are subject to a Board of Adjustments public hearing according to Section 12.4.9, Zoning Permit with Special Exception Review, which grants the Board of Adjustment the authority to impose conditions on the specified use to mitigate any potential impacts. Such uses shall comply with any applicable use limitations noted in the last column of the use table (“Applicable Use Limitations”), as well as the review criteria stated in Section 12.4.9, Zoning Permit with Special Exception Review.
- 5. Uses Where More Than One Zoning Procedure Is Indicated**  
Where a table cell shows more than one zoning procedure applies to a use, for example “L-ZP/ZPIN”, the referenced use limitation (last table column) will indicate which zoning procedure applies in a specific case. For example, a table cell may indicate “L-ZPIN/ZPSE” for a use. This means that the ZPIN zoning procedure will apply, unless the applicable use limitation specifies the ZPSE zoning procedure is triggered (e.g., by proximity to a Protected District).

#### **9.5.6.4 Enclosure of Uses**

All primary, accessory and temporary uses must be established, operated and maintained within a Completely Enclosed Structure, unless otherwise specifically allowed by this Code. The Use ~~and Parking~~ Tables in Articles 3-9 indicate when a use may be established, operated or maintained outside Completely Enclosed Structure by including an asterisk “\*” next to the specific use type. For example, the asterisk following the “Telecommunication Tower\*” use type in the tables indicates that a telecommunication tower land use need not be enclosed.

### 9.5.6.5 District Specific Standards

KEY: \* = Need Not be Enclosed P = Permitted Use without Limitations L = Permitted Use with Limitations NP = Not Permitted Use  
 ZP = Zoning Permit Review ZPCIM = Subject to Zoning Permit Review with Community Information Meeting  
 ZPIN = Subject to Zoning Permit Review with Informational Notice ZPSE = Subject to Zoning Permit with Special Exception Review  
 When no ZP, ZPCIM, ZPIN, ZPSE listed = No Zoning Permit required

USE CATEGORY	SPECIFIC USE TYPE				APPLICABLE USE LIMITATIONS IN THE O-1 AND MHC ZONE DISTRICTS, WHERE APPLICABLE
		DIA	O-1	MHC	
<b>RESIDENTIAL PRIMARY USE CLASSIFICATION</b>					
Household Living	Dwelling, Single Unit		NP	<u>NP</u>	
	Dwelling, Two Unit		NP	<u>NP</u>	
	Dwelling, Multi-Unit		NP	<u>NP</u>	
	Dwelling, Live / Work		NP	<u>NP</u>	
	Manufactured Home Community • <del>No Parking Requirements</del>		NP	L-ZP	\$11.2.5
Residential Care	Residential Care, Type 1 • <del>Vehicle: .25/1,000 sf GFA</del> • <del>Bicycle: No requirement</del>	See Section 9.5.6.1.A, DIA Zone District for permitted uses, and <del>required parking</del>	L/L-ZP	<u>NP</u>	\$11.2.8; §11.2.9
	Residential Care, Type 2 • <del>Vehicle: .25/1,000 sf GFA</del> • <del>Bicycle: No requirement</del>		L-ZP	<u>NP</u>	\$11.2.8; §11.2.10
	Residential Care, Type 3 • <del>Vehicle: .25/1,000 sf GFA</del> • <del>Bicycle: No requirement</del>		L-ZPCIM	<u>NP</u>	\$11.2.8; §11.2.11
	Residential Care, Type 4 • <del>Vehicle: .25/1,000 sf GFA</del> • <del>Bicycle: No requirement</del>		L-ZPCIM	<u>NP</u>	\$11.2.8; §11.2.12
Congregate Living	All Types • <del>Vehicle: .5/1,000 sf GFA</del> • <del>Bicycle: 1/20,000 sf GFA</del>		NP	<u>NP</u>	
<b>CIVIC, PUBLIC &amp; INSTITUTIONAL PRIMARY USE CLASSIFICATION</b>					
Basic Utilities	Utility, Major Impact* • <del>Vehicle: .5/1,000 sf GFA</del> • <del>Bicycle: No requirement</del>		L-ZPSE	NP	§ 11.3.1
	Utility, Minor Impact* • <del>Vehicle: .5/1,000 sf GFA</del> • <del>Bicycle: No requirement</del>		L-ZP	NP	§ 11.3.2
Community/ Public Services	Community Center* • <del>Vehicle: .5/1,000 sf GFA</del> • <del>Bicycle: 1/10,000 s.f. GFA (0/100)</del>	See Section 9.5.6.1.A, DIA Zone District for permitted uses, and <del>required parking</del>	L-ZP	NP	§ 11.3.3
	Day Care Center • <del>Vehicle: 1/1,000 sf GFA</del> • <del>Bicycle: 1/10,000 sf GFA (0/100)</del>		P-ZPIN	NP	
	Postal Facility, Neighborhood		NP	NP	
	Postal Processing Center		NP	NP	
	Public Safety Facility • <del>Vehicle: 1/1,000 sf GFA</del> • <del>Bicycle: 1/10,000 sf GFA (0/100)</del>		P-ZP	NP	
	Hospital		NP	NP	
	Correctional Institution • <del>Vehicle: .25/unit</del> • <del>Bicycle: No requirement</del>		P-ZP	NP	

KEY: \* = Need Not be Enclosed P = Permitted Use without Limitations L = Permitted Use with Limitations NP = Not Permitted Use  
 ZP = Zoning Permit Review ZPCIM = Subject to Zoning Permit Review with Community Information Meeting  
 ZPIN = Subject to Zoning Permit Review with Informational Notice ZPSE = Subject to Zoning Permit with Special Exception Review  
 When no ZP, ZPCIM, ZPIN, ZPSE listed = No Zoning Permit required

USE CATEGORY	SPECIFIC USE TYPE				APPLICABLE USE LIMITATIONS IN THE O-1 AND MHC ZONE DISTRICTS, WHERE APPLICABLE
		DIA	O-1	MHC	
Cultural/Special Purpose/ Public Parks & Open Space	Cemetery* • <del>No Parking Requirements</del>	See Section 9.5.6.1.A, DIA Zone District for permitted uses, and required parking	P-ZP	NP	
	Library • <del>Vehicle: 1/1,000 sf GFA</del> • <del>Bicycle: 1/10,000 sf GFA (0/100)</del>		P-ZP	NP	
	Museum • <del>Vehicle: 1/1,000 sf GFA</del> • <del>Bicycle: 1/10,000 sf GFA (0/100)</del>		P-ZP	NP	
	City Park*		NP	NP	
	Open Space - Conservation* • <del>No Parking Requirements</del>		P-ZP	NP	
Education	Elementary or Secondary School • <del>Vehicle-High School: 2/1,000 sf GFA</del> • <del>Bicycle-High School: 1/20,000 sf GFA (0/100)</del> • <del>Vehicle-All Others: 1/1,000 sf GFA</del> • <del>Bicycle-All Others: 1/10,000 sf GFA (0/100)</del>	See Section 9.5.6.1.A, DIA Zone District for permitted uses, and required parking	P-ZP	NP	
	University or College		NP	NP	
	Vocational or Professional School		NP	NP	
Public and Religious Assembly	All Types		NP	NP	
<b>COMMERCIAL SALES, SERVICES, &amp; REPAIR PRIMARY USE CLASSIFICATION</b>					
Adult Business	All Types	See Section 9.5.6.1.A, DIA Zone District for permitted uses, and required parking	NP	NP	See Section 9.4.4, Use Overlay Districts, for adult business use allowance in the UO-1 District.
Arts, Recreation & Entertainment	Arts, Recreation and Entertainment Services, Indoor		NP	NP	
	Arts, Recreation and Entertainment Services, Outdoor* • <del>Vehicle: 2.5/1,000 sf GFA</del> • <del>Bicycle: 1/20,000 sf GFA (20/80)</del>		L-ZP	NP	§ 11.4.3
	Event Space with Alternate Parking and Loading* • <del>Vehicle: No requirement</del> • <del>Bicycle: No requirement</del>		NP	NP	
Sports and/or Entertainment Arena or Stadium*			NP	NP	
Nonresidential Uses in Existing Business Structures In Residential Zones			Not Applicable	NP	
Parking of Vehicles	Parking, Garage • <del>No Parking Requirements</del>		P-ZP	NP	
	Parking, Surface* • <del>No Parking Requirements</del>	P-ZP	NP		
Eating & Drinking Establishments	All Types	NP	NP		

KEY: \* = Need Not be Enclosed P = Permitted Use without Limitations L = Permitted Use with Limitations NP = Not Permitted Use  
 ZP = Zoning Permit Review ZPCIM = Subject to Zoning Permit Review with Community Information Meeting  
 ZPIN = Subject to Zoning Permit Review with Informational Notice ZPSE = Subject to Zoning Permit with Special Exception Review  
 When no ZP, ZPCIM, ZPIN, ZPSE listed = No Zoning Permit required

USE CATEGORY	SPECIFIC USE TYPE				APPLICABLE USE LIMITATIONS IN THE O-1 AND MHC ZONE DISTRICTS, WHERE APPLICABLE
		DIA	O-1	MHC	
Lodging Accommodations	Bed and Breakfast Lodging	See Section 9.5.6.1.A, DIA Zone District for permitted uses, <del>and required parking</del>	NP	NP	
	Lodging Accommodations, All Others		NP	NP	
Office	Dental / Medical Office or Clinic		NP	NP	
	Office, All Others		NP	NP	
Retail Sales, Service & Repair (Not Including Vehicle or Equipment Sales, Service & Repair)	Animal Sales and Services, Household Pets Only		NP	NP	
	Animal Sales and Services, All Others		NP	NP	
	Food Sales or Market		NP	NP	
	Pawn Shop		NP	NP	
	Retail Sales, Service & Repair -- Outdoor*		NP	NP	
	Retail Sales, Service & Repair - Firearms Sales		NP	NP	
	Retail Sales, Service & Repair, All Others		NP	NP	
Vehicle / Equipment Sales, Rentals, Service & Repair	Automobile Emissions Inspection Facility		NP	NP	
	Automobile Services, Light		NP	NP	
	Automobile Services, Heavy		NP	NP	
	Automobile / Motorcycle / Light Truck Sales, Rentals, Leasing; Pawn Lot or Vehicle Auctioneer*		NP	NP	
	Heavy Vehicle/ Equipment Sales, Rentals & Service*	NP	NP		

KEY: \* = Need Not be Enclosed P = Permitted Use without Limitations L = Permitted Use with Limitations NP = Not Permitted Use  
 ZP = Zoning Permit Review ZPCIM = Subject to Zoning Permit Review with Community Information Meeting  
 ZPIN = Subject to Zoning Permit Review with Informational Notice ZPSE = Subject to Zoning Permit with Special Exception Review  
 When no ZP, ZPCIM, ZPIN, ZPSE listed = No Zoning Permit required

USE CATEGORY	SPECIFIC USE TYPE				APPLICABLE USE LIMITATIONS IN THE O-1 AND MHC ZONE DISTRICTS, WHERE APPLICABLE
		DIA	O-1	MHC	
<b>INDUSTRIAL, MANUFACTURING &amp; WHOLESALE PRIMARY USE CLASSIFICATION</b>					
Communications and Information	Antennas Not Attached to a Tower* • <del>No Parking Requirements</del>	See Section 9.5.6.1.A, DIA Zone District for permitted uses, <del>and required parking</del>	L-ZP	NP	§ 11.5.2
	Communication Services		NP	NP	
	Telecommunications Towers* • <del>No Parking Requirements</del>		L-ZP/ZPIN/ ZPSE	NP	§11.5.2
	Telecommunications Tower - Alternative Structure • <del>No Parking Requirements</del>		L-ZP/ZPIN	NP	§11.5.2
	Telecommunication Facilities -- All Others* • <del>No Parking Requirements</del>		L-ZPIN	NP	§11.5.2
Industrial Services	Contractors, Special Trade - General		NP	NP	
	Contractors, Special Trade - Heavy/Contractor Yard*		NP	NP	
	Food Preparation and Sales, Commercial		NP	NP	
	Laboratory, Research, Development and Technological Services		NP	NP	
	Service/Repair, Commercial		NP	NP	
Manufacturing and Production	Manufacturing, Fabrication & Assembly -- Custom	NP	NP		
	Manufacturing, Fabrication & Assembly -- General	NP	NP		
	Manufacturing, Fabrication & Assembly -- Heavy	NP	NP		
Mining & Extraction and Energy Producing Systems	Oil, Gas -- Production, Drilling* • <del>Vehicle: 3/1,000 s.f. GFA</del> • <del>Bicycle: No requirement</del>	L-ZP	NP	§11.5.11	
	Sand or Gravel Quarry*	NP	NP		
	Wind Energy Conversion Systems*	NP	NP		



KEY: \* = Need Not be Enclosed P = Permitted Use without Limitations L = Permitted Use with Limitations NP = Not Permitted Use  
 ZP = Zoning Permit Review ZPCIM = Subject to Zoning Permit Review with Community Information Meeting  
 ZPIN = Subject to Zoning Permit Review with Informational Notice ZPSE = Subject to Zoning Permit with Special Exception Review  
 When no ZP, ZPCIM, ZPIN, ZPSE listed = No Zoning Permit required

USE CATEGORY	SPECIFIC USE TYPE				APPLICABLE USE LIMITATIONS IN THE O-1 AND MHC ZONE DISTRICTS, WHERE APPLICABLE
		DIA	O-1	MHC	
Transportation Facilities	Airport*	P-ZP	NP	NP	
	Helipad, Helistop, Heliport*		NP	NP	
	Railroad Facilities*		NP	NP	
	Railway Right-of-Way* • <del>No Parking Requirements</del>		P-ZP	NP	
	Terminal, Station or Service Facility for Passenger Transit System		NP	NP	
	Terminal, Freight, Air Courier Services		NP	NP	
Waste Related Services	Automobile Parts Recycling Business	See Section 9.5.6.1.A, DIA Zone District for permitted uses, <del>and required parking</del>	NP	NP	
	Junkyard*		NP	NP	
	Recycling Center		NP	NP	
	Recycling Collection Station		NP	NP	
	Recycling Plant, Scrap Processor		NP	NP	
	Solid Waste Facility		NP	NP	
Wholesale, Storage, Warehouse & Distribution	Automobile Towing Service Storage Yard*	See Section 9.5.6.1.A, DIA Zone District for permitted uses, <del>and required parking</del>	NP	NP	
	Mini-storage Facility		NP	NP	
	Vehicle Storage, Commercial*		NP	NP	
	Wholesale Trade or Storage, General		NP	NP	
	Wholesale Trade or Storage, Light • <del>Vehicle: .5 / 1,000 sf GFA</del> • <del>Bicycle: No requirement</del>		P-ZP	NP	
<b>AGRICULTURE PRIMARY USE CLASSIFICATION</b>					
Agriculture	Aquaculture*	See Section 9.5.6.1.A, DIA Zone District for permitted uses, <del>and required parking</del>	NP	NP	
	Garden, Urban* • <del>Vehicle: .5 / 1,000 sf GFA</del> • <del>Bicycle: No requirement</del>		L-ZP	NP	§11.6.2
	Husbandry, Animal*		NP	NP	
	Husbandry, Plant*		NP	NP	
	Plant Nursery* • <del>Vehicle: .5 / 1,000 sf GFA</del> • <del>Bicycle: No requirement</del>		L-ZP	NP	§11.6.5

KEY: \* = Need Not be Enclosed P = Permitted Use without Limitations L = Permitted Use with Limitations NP = Not Permitted Use  
 ZP = Zoning Permit Review ZPCIM = Subject to Zoning Permit Review with Community Information Meeting  
 ZPIN = Subject to Zoning Permit Review with Informational Notice ZPSE = Subject to Zoning Permit with Special Exception Review  
 When no ZP, ZPCIM, ZPIN, ZPSE listed = No Zoning Permit required

USE CATEGORY	SPECIFIC USE TYPE				APPLICABLE USE LIMITATIONS IN THE O-1 AND MHC ZONE DISTRICTS, WHERE APPLICABLE
		DIA	O-1	MHC	
<b>ACCESSORY TO PRIMARY RESIDENTIAL USES USE CLASSIFICATION</b>					
Accessory to Primary Residential Uses  ( <del>Parking is Not Required for Accessory Uses Unless Specifically Stated in this Table or in an Applicable Use Limitation</del> )	Unlisted Accessory Uses	See Section 9.5.6.1.A, DIA Zone District for permitted uses, <del>and required parking</del>	L	L	\$11.7
	Accessory Dwelling Unit		NP	NP	
	Domestic Employee		L	L	\$11.7; §11.8.3
	Garden*		L	L	\$11.7; §11.8.4
	Keeping of Household Pets*		NP	L/L-ZPIN	
	Keeping and Off-Street Parking of Vehicles, Motorcycles, Trailers & Recreational Vehicles*		NP	L	
	Kennel or Exercise Run*		NP	L	
	Limited Commercial Sales, Services Accessory to Multi-Unit Dwelling Use		NP	NP	
	Outdoor Storage, Residential*		L	L	\$11.7; §11.8.8
	Second Kitchen Accessory to Single Unit Dwelling Use		NP	NP	
	Short-term Rental		NP	L	
	Vehicle Storage, Repair and Maintenance*		NP	L	
	Wind Energy Conversion Systems*		Not Applicable - See Permitted Primary Uses	L-ZPIN/ ZPSE	
Yard or Garage Sales*	NP	L			
<b>HOME OCCUPATIONS ACCESSORY TO PRIMARY RESIDENTIAL USES USE CLASSIFICATION</b>					
Home Occupations	Adult Care Home	See Section 9.5.6.1.A, DIA Zone District for permitted uses, <del>and required parking</del>	NP	L-ZP	\$11.9
	Animal Care Services		NP	L-ZP	\$11.9; §11.9.4.1
	Artist Studio		NP	L-ZP	\$11.9; §11.9.4.2
	Child Care Home, Small		NP	L-ZP	\$11.9; §11.9.4.3
	Child Care Home, Large (7-12)		NP	NP	
	Food Preparation		NP	L-ZP	\$11.9; §11.9.4.4
	Fresh Produce and Cottage Foods Sales*		NP	L-ZP	\$11.9; §11.9.4.5
	Limited Retail Services and Repair		NP	L-ZP	\$11.9; §11.9.4.6
	Office, Non-Medical, Non-Dental		NP	L-ZP	\$11.9; §11.9.4.7
	Online Retail Sales		NP	L-ZP	\$11.9; §11.9.4.8
	Professional Studio		NP	L-ZP	\$11.9; §11.9.4.9
	All Other Types		NP	NP	
	Unlisted Home Occupations		NP	L-ZPIN	\$11.9; §11.9.5

KEY: \* = Need Not be Enclosed P = Permitted Use without Limitations L = Permitted Use with Limitations NP = Not Permitted Use  
 ZP = Zoning Permit Review ZPCIM = Subject to Zoning Permit Review with Community Information Meeting  
 ZPIN = Subject to Zoning Permit Review with Informational Notice ZPSE = Subject to Zoning Permit with Special Exception Review  
 When no ZP, ZPCIM, ZPIN, ZPSE listed = No Zoning Permit required

USE CATEGORY	SPECIFIC USE TYPE				APPLICABLE USE LIMITATIONS IN THE O-1 AND MHC ZONE DISTRICTS, WHERE APPLICABLE
		DIA	O-1	MHC	
<b>ACCESSORY TO PRIMARY NONRESIDENTIAL USES USE CLASSIFICATION</b>					
Accessory to Primary Nonresidential Uses <del>Accessory to Primary Non-residential Uses</del>	Unlisted Accessory Uses		L	NP	§11.7; §11.10.1
	Amusement Devices Accessory to Eating/ Drinking Establishments, College/University and Theater Uses		NP	NP	
	Automobile Rental Services Accessory to Certain Retail Uses*		NP	NP	
	Book or gift store; media recording and production facilities accessory to public libraries, museums, places of religious assembly, colleges or universities		L	NP	§ 11.7
	Car Wash Bay Accessory to Automobile Services		NP	NP	
	College accessory to a Place for Religious Assembly		NP	NP	
	Conference Facilities Accessory to Hotel Use		NP	NP	
	Drive Through Facility Accessory to Eating/ Drinking Establishments and to Retail Sales, Service, and Repair Uses*		NP	NP	
	Emergency Vehicle Access Point		NP	NP	
	Garden*	See Section 9.5.6.1.A, DIA Zone District for permitted uses, and required parking	L	NP	§11.7; §11.10.10
	Keeping of Animals		L/L-ZP/ L-ZPIN	NP	§11.7; §11.10.11
	Limited Commercial Sales, Services		L	NP	§11.7; §11.10.1
	Nonresidential Uses in Existing Business Structures In Residential Zones - Accessory Uses		Not Applicable	NP	
	Occasional Sales, Services Accessory to Primary Places of Religious Assembly or Primary Uses Operated by Nonprofit Organizations*		NP	NP	
	Outdoor Gathering Area*		NP	NP	
	Outdoor Entertainment Accessory to an Eating/Drinking Establishment Use*		NP	NP	
	Outdoor Retail Sale and Display*		L-ZP	NP	§11.7; §11.10.15
	Outdoor Storage, Limited*		NP	NP	
	Outdoor Storage, General*		NP	NP	
	Rental or Sales of Adult Material Accessory to a Permitted Bookstore Retail Sales Use		NP	NP	
Retail Food Establishment, Mobile (Food Truck)*	NP		NP		

KEY: \* = Need Not be Enclosed P = Permitted Use without Limitations L = Permitted Use with Limitations NP = Not Permitted Use  
 ZP = Zoning Permit Review ZPCIM = Subject to Zoning Permit Review with Community Information Meeting  
 ZPIN = Subject to Zoning Permit Review with Informational Notice ZPSE = Subject to Zoning Permit with Special Exception Review  
 When no ZP, ZPCIM, ZPIN, ZPSE listed = No Zoning Permit required

USE CATEGORY	SPECIFIC USE TYPE	APPLICABLE USE LIMITATIONS IN THE O-1 AND MHC ZONE DISTRICTS, WHERE APPLICABLE			
		DIA	O-1	MHC	
<b>TEMPORARY USE CLASSIFICATION</b>					
Temporary Uses	Unlisted Temporary Uses	See Section 9.5.6.1.A, DIA Zone District for permitted uses, <del>and required parking</del>	L	L	\$11.11.1
	Ambulance Service - Temporary		L-ZP Not Applicable - See Permitted Primary Uses	NP	\$11.11.2
	Amusement / Entertainment - Temporary*		NP	NP	
	Bazaar, Carnival, Circus or Special Event*		L-ZP	NP	\$11.11.4
	Building or yard for construction materials*		L-ZP	NP	\$11.11.5
	Concrete, Asphalt, and Rock Crushing Facility*		L-ZP	NP	\$11.11.6
	Fence for Demolition or Construction Work		L-ZP	NP	\$11.11.7
	Health Care Center		NP	NP	
	Noncommercial Concrete Batching Plant*		L-ZP	NP	\$11.11.9
	Outdoor Retail Sales - Pedestrian / Transit Mall*		NP	NP	
	Outdoor Retail Sales*		NP	NP	
	Outdoor Sales, Seasonal*		L-ZP	NP	\$11.11.12
	Parking Lot Designated for a Special Event*		L-ZP	NP	\$11.11.13
	Retail Food Establishment, Mobile (Food Truck)*		NP	NP	
	Temporary Construction Office		L-ZP	L-ZP	\$11.11.15
	Temporary Office - Real Estate Sales		L-ZP	L-ZP	\$11.11.16
	Temporary Managed Community*		L-ZPCIM	NP	\$11.11.17
Tent for Religious Services	NP	NP			

### 9.6.1.3 Requirement for PUD District Plan

All applications for rezoning to a PUD District shall contain the information and representations required by this Division 9.6 and by Section 12.4.10, Official Map Amendment, and a PUD District Plan that complies with the following:

#### A. Choice of PUD District Plan Type

##### 1. General PUD District Plan

If development is to proceed in phases or over an extended period of time, or if more general zoning is desired prior to preparation of more detailed site development and pre-construction plans, the applicant may submit a “General PUD District Plan” covering the entire PUD District area. After the PUD District rezoning with a General PUD District Plan is approved, one or more site development plans shall be submitted for each phase of development and shall follow the general development concept established in the General PUD District Plan. See Section 12.4.3, Site Development Plan, for the procedure and review criteria applicable to site development plans.

##### 2. Detailed PUD District Plan

If development is not to be completed in phases or over an extended period of time, or if an applicant is prepared to submit more detailed site development plan or pre-construction plans, the applicant may submit a “Detailed PUD District Plan” covering the entire PUD District area. After the PUD District rezoning with a Detailed PUD District plan is approved, the Detailed PUD District Plan shall constitute a site development plan, enabling the applicant to proceed directly to final zoning / building permit approval (no intervening site development plan review step under Section 12.4.3).

#### B. PUD District Plan Contents -- Permitted Uses and Procedures

All PUD District Plans shall specify permitted primary, accessory and temporary uses, and may specify applicable use and development review procedures, in compliance with the following standards.

1. A PUD District Plan shall permit any use which is a permitted use in any zone district when such use is provided for, enumerated, and approved in the PUD District Plan.
2. All use limitations in this Code shall apply to the uses in the PUD District unless expressly waived or modified in the PUD District Plan.
3. A PUD District Plan may subject the establishment of a permitted use or the development of an allowed building form to any procedure established in Article 12, Zoning Procedures and Enforcement, including Zoning Permit Review with Information Notice, Special Exception review, Site Development Plan review, or Administrative Adjustment. However, a PUD District Plan shall not establish or include any use or development review procedure different from a procedure established in Article 12, Zoning Procedures and Enforcement.
4. A PUD District Plan may provide for future amendment by subarea, platted lots, or metes and bounds parcels, as allowed in Section 9.6.1.4, Amendments to Approved PUD District Plans.

#### C. PUD District Plan Contents -- Applicable Design Standards

##### 1. Required PUD District Plan Elements

While the level of detail will vary between a General PUD District Plan and a Detailed PUD District Plan, all PUD District Plans shall include or address the following elements, through specific standards wherever possible. All design standards stated in Article 10, General Design Standards, shall apply in the PUD District Plan unless expressly waived or modified in the PUD District Plan.

- a. A written statement of development and design intent for the proposed PUD District Plan, consistent with the purpose and intent of the PUD District stated in Section 9.6.1.1. above.
- b. Relationship of the PUD District Plan to existing Neighborhood Context of surrounding properties
- c. Building form standards, including building height, siting, and design element standards formatted similarly to the Primary Building Form Standards found in Articles 3 through 7.
- d. Appropriate building, use, or other transitions to adjacent properties, development, and uses.
- e. Parking for vehicles and bicycles.
- f. Vehicle, bicycle, and pedestrian access and circulation, including connections to adjacent properties and public amenities or facilities (e.g., public parks, transit, open space, schools).
- g. Off-street loading.
- h. Landscaping, screening, fence and wall standards.
- i. Grading, including tree preservation and removal.
- j. Outdoor lighting.
- k. Outdoor storage, sales and display.
- l. Signs.
- m. Limitations on external effects.
- n. Mitigation of potential adverse impacts on surrounding properties.

## 2. **Optional PUD District Plan Elements**

In addition to the required elements stated in this subsection, a PUD District Plan may include:

- a. Requirements specifying the maximum amount of vehicle parking that may be provided.
- b. ~~d~~Design standards different than the type and subject matter of standards included in this Code, including without limitation, enhanced streetscape standards, minimum open space configuration or design standards, and minimum architectural design standards for buildings in the PUD District.

## 3. **Prohibited PUD District Plan Elements**

A PUD District Plan shall not include requirements specifying a minimum amount of vehicle parking.

## D. **Effect of Approval of PUD District Plan**

### 1. **Conformance with PUD District Plan Required**

All development in a PUD District shall conform to the approved PUD District Plan. Minor deviations may be permitted only according to this subsection.

### 2. **Minor Deviations from Approved PUD District Plans**

The Zoning Administrator, Manager, and Manager of the Department of Transportation and Infrastructure ("DOTI") jointly may authorize minor deviations from previously approved PUD District Plans during the site development plan review (see Section 12.4.3) only when such deviations are necessary in light of technical or engineering

### 9.7.3.3 Building Form Standards for Primary Structures

#### A. Applicability

All development, except detached accessory structures, in all the Master Planned Context zone districts

#### B. District Specific Standards Summary

The table below states the building forms allowed in each zone district. The table also summarizes the maximum number of structures allowed per Zone Lot, which is stated in more detail in Section 1.2.3.5, Number of Uses and Structures Allowed per Zone Lot.

See also Division 1.4, Building Form Standards - General Provisions, for additional standards related to initial assignment of building form standards to new and existing structures and for rules governing combining or changing building forms. Building Connectors between two detached structures shall follow the standards provided in Section 1.4.5, Applicable Building Form Standards for Detached Structures with Building Connector.

Master Planned (M-) Neighborhood Context Zone Districts		Max Number of Primary Structures per Zone Lot	Building Forms								
			Suburban House	Urban House	Duplex	Town House	Garden Court	Row House	Apartment	General	Industrial
Row House (RH)	M-RH-3	no max		■	■		■	■			
Residential Mixed Use (RX)	M-RX-3, -5	no max		■	■					■	
	M-RX-5A	no max	■	■	■	■	■	■	■	□	
Commercial Corridor (CC)	M-CC-5	no max	■		■				■	■	
Commercial Mixed Use (MX)	M-MX-5	no max		■	■					■	
Industrial Mixed Use (IMX)	M-IMX-5, -8, -12	no max						■	■	■	■
General Mixed Use (GMX)	M-GMX	no max	■	■	■	■	■	■	■	■	■

■ = Allowed □ = Allowed subject to limitations.

### 9.7.3.4 District Specific Standards

#### A. Suburban House

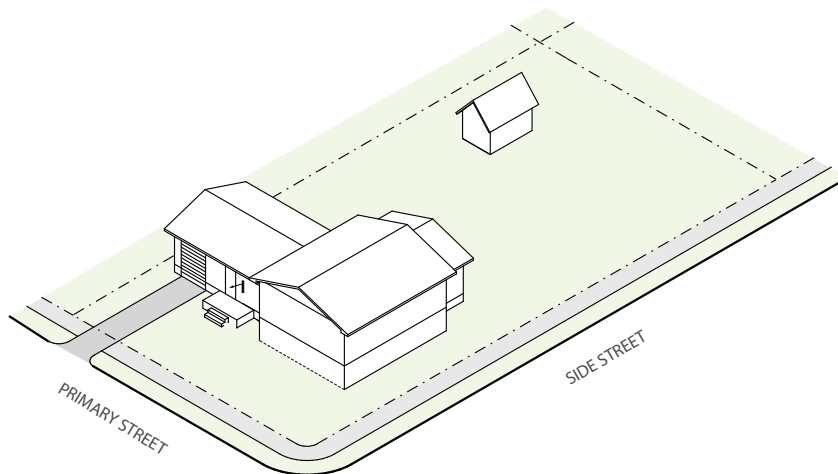
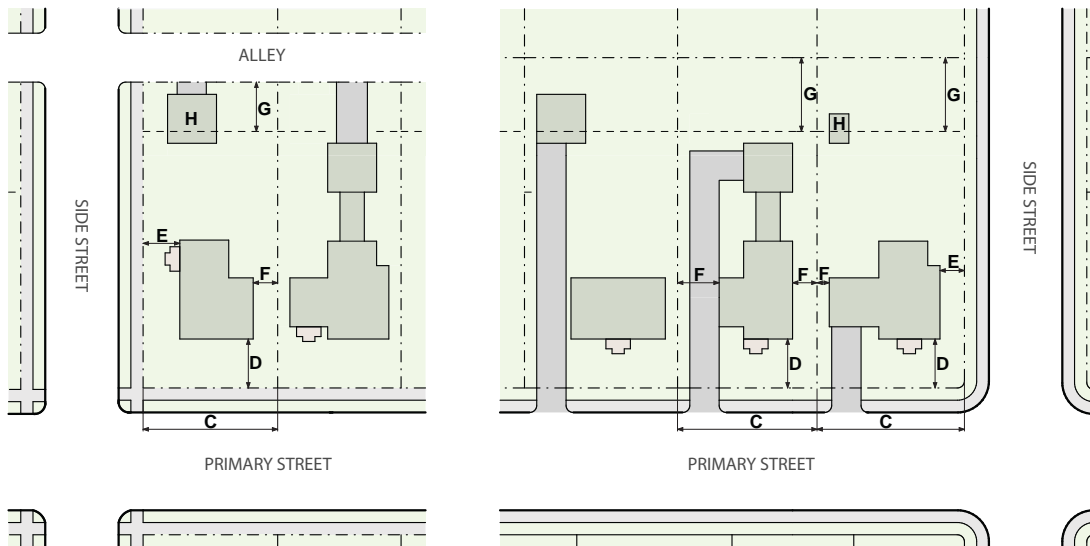
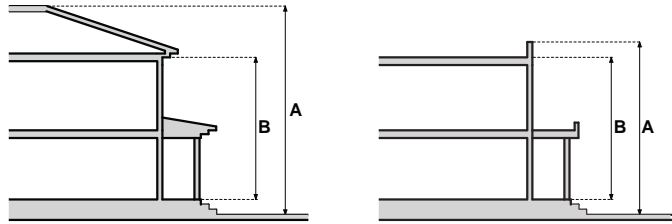



## SUBURBAN HOUSE

<b>HEIGHT</b>		M-RX-5A M-GMX, M-CC-5
A	Stories (max)	2.5
A	Feet (max)	40'
<b>SITING</b>		M-RX-5A M-GMX, M-CC-5
<b>ZONE LOT</b>		
	Zone Lot Size (min)	2,800 sf
C	Zone Lot Width (min)	25'
<b>SETBACKS</b>		
D	Primary Street (min)	10'
E	Side Street (min)	10'
F	Side, interior (min)	3'
G	Rear (min)	10'
	Building Coverage per Zone Lot, including all accessory structures (max)	65%
<b>PARKING</b>		
	Vehicle Access	From Alley; or Street access allowed when no Alley present (See Sec. 9.7.7.6)
H	<b>DETACHED ACCESSORY STRUCTURES</b>	See Sec. 9.7.4
<b>DESIGN ELEMENTS</b>		M-RX-5A M-GMX, M-CC-5
<b>BUILDING CONFIGURATION</b>		
	Attached Garage Allowed	Shall not project forward of any part of a Primary Street-facing façade of a primary structure. Where an Unenclosed Porch is located forward of the Primary Street-facing Façade of the primary structure, the attached garage shall not project forward of that Unenclosed Porch.
<b>STREET LEVEL ACTIVATION</b>		
I	Pedestrian Access, Primary Street	Entry Feature
	Design Criteria	See Section 9.7.5.1
<b>USES</b>		M-RX-5A M-GMX, M-CC-5
		Primary Uses shall be limited to Single Unit Dwelling. See Section 9.7.9, <u>Uses</u> , and <u>Parking</u> .

See Sections 9.7.5 - 9.7.7 for Supplemental Design Standards, Design Standard Alternatives and Design Standard Exceptions.

## URBAN HOUSE

		M-RH-3
<b>HEIGHT</b>		M-RX-3, M-RX-5, M-RX-5A, M-GMX, M-MX-5
A	Stories (max)	2.5
A	Feet (max)	42'
<b>SITING</b>		M-RH-3
<b>ZONE LOT</b>		M-RX-3, M-RX-5, M-RX-5A, M-GMX, M-MX-5
	Zone Lot Size (min)	3,000 sf
C	Zone Lot Width (min)	25'
<b>SETBACKS</b>		
D	Primary Street (min)	10'
E	Side Street (min)	10'
F	Side, interior (min)	3'
G	Rear (min)	0'
	Building Coverage per Zone Lot, including all accessory structures (max)	75%
<b>PARKING</b>		
	Parking and Drive Lot Coverage in Primary Street Setback (max)	Maximum 16-foot wide measured parallel to the Primary Street zone lot line for any length, or 33% of the zone lot area within the Primary Street setback, whichever is greater
	Vehicle Access	From Alley; or Street access allowed when no Alley present (See Section 9.7.7.6)
H	<b>DETACHED ACCESSORY STRUCTURES</b>	(See Section 9.7.4)
<b>DESIGN ELEMENTS</b>		M-RH-3
<b>BUILDING CONFIGURATION</b>		M-RX-3, M-RX-5, M-RX-5A, M-GMX, M-MX-5
	Primary Street Facing Attached Garage Door Width in front 50% of zone lot depth(max)	35% of the entire width of the Primary Street-facing façade of the primary structure or 16', whichever is greater
	Attached Garage Allowed	Shall not be located closer to the Primary Street Zone Lot Line than the Primary Street-facing façade(s) comprising at least 65% of the total width of the primary structure enclosing the primary use. (2) Shall be setback 20' from back of sidewalk for building walls with garage doors that are facing a street
<b>STREET LEVEL ACTIVATION</b>		
	Design Criteria	(See Section 9.7.5.1)
I	Pedestrian Access, Primary Street	Entry Feature
<b>USES</b>		M-RH-3, M-RX-3, M-RX-5, M-RX-5A, M-GMX, M-MX-5
		Primary Uses shall be limited to Single Unit Dwelling and permitted Residential Care, Congregate Living and Nonresidential uses. (See Section 9.7.9, <a href="#">Uses</a> , and <a href="#">Parking</a> )
See Sections 9.7.5 - 9.7.7 for Supplemental Design Standards, Design Standard Alternatives and Design Standard Exceptions.		

## DUPLEX

		M-RH-3	M-RX-3	M-RX-5	M-MX-5
<b>HEIGHT</b>					
A	Stories (max)		2.5		2.5
A	Feet (max)		42'		42'
<b>SITING</b>					
<b>ZONE LOT</b>					
	Zone Lot Size (min)		4,000 sf		4,000 sf
C	Zone Lot Width (min)		45'		45'
<b>SETBACKS</b>					
D	Primary Street (min)		10'		10'
E	Side Street (min)		10'		10'
F	Side, interior (min)		5'		3'
G	Rear (min)		0'		0'
	Building Coverage per Zone Lot, including all accessory structures (max)		75%		na
<b>PARKING</b>					
	Parking and Drive Lot Coverage in Primary Street Setback (max)				50%
	Vehicle Access		From Alley; or Street access allowed when no Alley present (See Section 9.7.7.6)		
H	<b>DETACHED ACCESSORY STRUCTURES</b>		(See Section 9.7.4)		
<b>DESIGN ELEMENTS</b>					
<b>BUILDING CONFIGURATION</b>					
	Primary Street Facing Attached Garage Door Width in front 50% of zone lot depth(max)		35% of the entire width of the Primary Street-facing façade of the primary structure or 16', whichever is greater		
	Attached Garage Allowed		Shall not be located closer to the Primary Street Zone Lot Line than the Primary Street-facing façade(s) comprising at least 65% of the total width of the primary structure enclosing the primary use.		
<b>STREET LEVEL ACTIVATION</b>					
	Design Criteria		(See Section 9.7.5.1)		
I	Pedestrian Access, Primary Street		Entry Feature		
<b>USES</b>			M-RH-3, M-RX-3, M-RX-5, M-RX-5A, M-MX-5, M-CC-5, M-GMX		
			Primary Uses shall be limited to Two Unit Dwelling and permitted Residential Care, Congregate Living, and Nonresidential uses. (See Section 9.7.9, <u>Uses, and Parking</u> )		

See Sections 9.7.5 - 9.7.7 for Supplemental Design Standards, Design Standard Alternatives and Design Standard Exceptions.

## GARDEN COURT

<b>HEIGHT</b>		<b>M-RH-3</b>	<b>M-RX-5A, M-GMX</b>
<b>A</b>	Stories (max)	2.5	2.5
<b>A</b>	Feet (max)	42'	42'
<b>B</b>	Side Wall Height (Max)	34'	34'

<b>SITING</b>		<b>M-RH-3</b>	<b>M-RX-5A, M-GMX</b>
<b>ZONE LOT</b>			
	Zone Lot Size (min)	6,000 sf	na
<b>SETBACKS</b>			
<b>C</b>	Primary Street (min)	10'	10'
<b>D</b>	Side Street (min)	10'	10'
<b>E</b>	Side, interior (min)	5'	5'
<b>F</b>	Rear, where Alley (public or private) abuts a Rear Zone Lot Line (min)	5'	0'
<b>F</b>	Rear, where Alley (public or private) does not abut a Rear Zone Lot Line (min)	15'	0'
	Building Coverage per Zone Lot, including all accessory structures (max)	75%	na
<b>PARKING</b>			
	Surface Parking Location	No surface parking between building and Primary Street	
	Vehicle Access	From Alley; or Street access allowed when no Alley present (See Sec. 9.7.7.6)	
<b>ACCESSORY STRUCTURES</b>			
<b>G</b>	Detached Accessory Structures Allowed	See Sec. 9.7.4	

<b>DESIGN ELEMENTS</b>		<b>M-RH-3</b>	<b>M-RX-5A, M-GMX</b>
<b>H</b>	Street-Facing Courtyard Width (min)	15'	15'
<b>I</b>	Street-Facing Courtyard Depth (min)	30'	30'
	Garden Court Design Standards	See Sec. 9.7.5.2	
	Attached Garage Allowed	May follow the General Detached Structure building form Side Street, Side Interior and Rear setbacks	
<b>STREET LEVEL ACTIVATION</b>			
<b>J</b>	Pedestrian Access, Primary Street	Each dwelling unit shall have a Street Level Entrance. A minimum two dwelling units shall each have an Entrance facing the Primary Street and all other dwelling units shall have an Entrance that faces either the Primary Street or the interior courtyard.	

<b>USES</b>		<b>M-RH-3, M-RX-5A, M-GMX</b>
		Primary Uses shall be limited to Multi Unit Dwelling (3+) and permitted Residential Care, Congregate Living, and Nonresidential uses. See Section 9.7.9, <a href="#">Uses</a> , and <a href="#">Parking</a>

See Sections 9.7.5 - 9.7.7 for Supplemental Design Standards, Design Standard Alternatives and Design Standard Exceptions.

## TOWN HOUSE

<b>HEIGHT</b>		M-RX-5A M-GMX
A	Stories (max)	5
A	Feet (max)	65'
<b>SITING</b>		M-RX-5A M-GMX
<b>ZONE LOT</b>		
	Zone Lot Size (min)	na
	Dwelling Units per Primary Residential Structure (min/max)	3/na
<b>REQUIRED BUILD-TO</b>		
C	Primary Street (min % within min/max)	50% 0'/80'
<b>SETBACKS</b>		
E	Primary Street (min)	10'
F	Side Street (min)	10'
G	Side, interior (min)	5'
	Side, interior, adjacent to Protected District (min)	10'
H	Rear, where Alley (public or private) abuts a Rear Zone Lot Line (min)	10'
H	Rear, where Alley (public or private) does not abut a Rear Zone Lot Line (min)	20'
<b>PARKING</b>		
	Vehicle Access	From Alley; or Street access allowed when no Alley present (See Sec. 9.7.7.6)
<b>ACCESSORY STRUCTURES</b>		
I	Detached Accessory Structures Allowed	See Sec. 9.7.4
<b>DESIGN ELEMENTS</b>		M-RX-5A M-GMX
<b>BUILDING CONFIGURATION</b>		
	Primary Street-Facing Attached Garage Door Width (max per unit)	16'
<b>STREET LEVEL ACTIVATION</b>		
L	Transparency, Primary Street (min)*	20%
M	Pedestrian Access	Entrance or Pedestrian Connection
<b>USES</b>		M-RX-5A M-GMX
Primary Uses shall be limited to Multi Unit Dwelling (3+) and permitted Residential Care, Congregate Living, and Nonresidential uses. See Section 9.7.9, <u>Uses, and Parking</u>		
See Sections 9.7.5 - 9.7.7 for Supplemental Design Standards, Design Standard Alternatives and Design Standard Exceptions.		
* Applies only to street-facing portions of building Façade located within 80' of the Primary and/or Side Street.		

## ROW HOUSE

				M-IMX-5 M-IMX-8 M-IMX-12 M-GMX
<b>HEIGHT</b>		M-RH-3	M-RX-5A	
<b>A</b>	Stories (max)	3	5	5
<b>A</b>	Feet (max)	55'	70'	70'
<b>B</b>	Side Wall Height (max)	49'	na	na

				M-IMX-5 M-IMX-8 M-IMX-12 M-GMX
<b>SITING</b>		M-RH-3	M-RX-5A	
<b>ZONE LOT</b>				
	Zone Lot Size (min)	6,000 sf	na	na
	Dwelling Units per Primary Residential Structure (min/max)	3/10	3/na	3/na

<b>REQUIRED BUILD-TO</b>				
<b>C</b>	Primary Street (min % within min/max)	na	60% 0'/15'	60% 0'/15'
<b>D</b>	Side Street (min % within min/max)	na	na	na

<b>SETBACKS</b>				
<b>E</b>	Primary Street (min)	10'	0'	0'
<b>F</b>	Side Street (min)	10'	0'	0'
<b>G</b>	Side, interior (min)	5'	0'	0'
	Side, interior, adjacent to Protected District (min)	na	5'	5'
<b>H</b>	Rear (min)	0'	0'	0'
	Rear, adjacent to Protected District, where Alley (public or private) abuts a Rear Zone Lot Line (min)	na	5'	5'
	Rear, adjacent to Protected District, where Alley (public or private) does not abut a Rear Zone Lot Line	na	10'	10'

<b>PARKING</b>				
	Surface Parking Location	Not allowed between the building and the Primary Street		
	Vehicle Access, 3 or more side-by-side dwelling units in one structure, and/or M-RH-3	From Alley; or Street access allowed when no Alley present. (See Sec. 9.7.7.6)		
	Vehicle Access, all other uses	Shall be determined as part of Site Development Plan Review		

<b>ACCESSORY STRUCTURES</b>				
<b>I</b>	Detached Accessory Structures Allowed	See Sec. 9.7.4		

				M-IMX-5 M-IMX-8 M-IMX-12 M-GMX
<b>DESIGN ELEMENTS</b>		M-RH-3	M-RX-5A	
<b>BUILDING CONFIGURATION</b>				
<b>J</b>	Upper Story Setback Above 27' adjacent to Protected District, Rear, alley/Rear, no alley /Side, interior (min)	15'/20'/25'	15'/20'/25'	15'/20'/25'
<b>K</b>	Upper Story Setback Above 51', adjacent to Protected District, Rear, alley/Rear, no alley/Side Interior (min)	na	na	30'/35'/40'
	Street facing garage door width per Primary Structure (max)	20'	20'	20'
	Attached Garage Allowed	May follow the General Detached Structure building form Side Street, Side Interior and Rear setbacks		na

<b>STREET LEVEL ACTIVATION</b>				
<b>L</b>	Transparency, Primary Street (min)	20%	20%	20%
<b>M</b>	Pedestrian Access, Primary Street	Entrance or Pedestrian Connection		

<b>USES</b>		M-RH-3; M-RX-5A; M-GMX and all M-IMX		
Permitted Primary Uses shall be limited to Multi Unit Dwelling (3+) and permitted Residential Care, Congregate Living, and Nonresidential Uses. See Section 9.7.9, Uses, and <b>Parking</b>				

See Sections 9.7.5 - 9.7.7 for Supplemental Design Standards, Design Standard Alternatives and Design Standard Exceptions.

## APARTMENT

					M-IMX-12
<b>HEIGHT</b>		M-RX-5A	M-IMX-5	M-IMX-8	M-GMX
A	Stories (max)	5	5	8	12
A	Feet (max)	70'	70'	100'	140'

					M-IMX-12
<b>SITING</b>		M-RX-5A	M-IMX-5	M-IMX-8	M-GMX
<b>REQUIRED BUILD-TO</b>					
B	Primary Street (% within min/max)	50%	50%	60%	50%
		0'/20'	0'/15'	0'/15'	0'/15'
<b>SETBACKS</b>					
C	Primary Street (min)	0'	0'	0'	0'
D	Side Street (min)	0'	0'	0'	0'
E	Side, interior (min)	0'	0'	0'	0'
	Side, interior, adjacent to Protected District (min)	10'	10'	10'	10'
F	Rear (min)	0'	0'	0'	0'
	Rear, adjacent to Protected District, where Alley (public or private) abuts a Rear Zone Lot Line (min)	5'	5'	5'	5'
	Rear, adjacent to Protected District, where Alley (public or private) does not abut a Rear Zone Lot Line	10'	10'	10'	10'
<b>PARKING</b>					
	Surface Parking Location	Not allowed between the building and the Primary Street			
	Vehicle Access, 3 or more side-by-side dwelling units in one structure	From Alley; or Street access allowed when no Alley present (Sec. 9.7.7.6)			
	Vehicle Access, all other permitted uses	Shall be determined as part of Site Development Plan Review			

					M-IMX-12
<b>DESIGN ELEMENTS</b>		M-RX-5A	M-IMX-5	M-IMX-8	M-GMX
<b>CONFIGURATION</b>					
G	Upper Story Setback Above 27', adjacent to Protected District, Rear, alley/Rear, no alley and Side Interior (min)	15'/20'/25'	15'/20'/25'	15'/20'/25'	15'/20'/25'
H	Upper Story Setback Above 51', adjacent to Protected District, Rear, alley/Rear, no alley and Side Interior (min)	na	30'/35'/40'	30'/35'/40'	30'/35'/40'
I	Upper Story Setback Above 70', adjacent to Protected District, Rear, alley/Rear, no alley and Side Interior (min)	na	na	90'/90'/90'	90'/90'/90'
<b>STREET LEVEL ACTIVATION</b>					
J	Transparency, Primary Street (min)	30%	30%	30%	30%
K	Transparency, Side Street (min)	25%	25%	25%	25%
L	Pedestrian Access, Primary Street	Pedestrian Connection			

<b>USES</b>	M-RX-5A; M-GMX and all M-IMX
	Permitted Primary Uses shall be limited to Multi Unit Dwelling (3+) and permitted Residential Care, Congregate Living, and Lodging Accommodations Uses.
	See Section 9.7.9, <a href="#">Uses, and Parking</a>

## GENERAL (1 OF 3)

<b>HEIGHT</b>		M-RX-3	M-RX-5	M-RX-5A*
A	Stories (max)	3	5	5
A	Feet (max)	45'	70'	70'

<b>SITING</b>		M-RX-3	M-RX-5	M-RX-5A*
<b>SETBACKS</b>				
C	Primary Street (min)	0'	0'	0'
D	Side Street (min)	0'	0'	0'
E	Side, interior (min)	0'	0'	0'
	Side Interior, adjacent to Protected District (min)	0'	10'	10'
F	Rear (min)	0'	0'	0'
	Rear, adjacent to Protected District, where Alley (public or private) abuts a Rear Zone Lot Line (min)	5'	5'	5'
	Rear, adjacent to Protected District, where Alley (public or private) does not abut a Rear Zone Lot Line	10'	10'	10'
<b>PARKING</b>				
	Surface Parking between building and Primary Street / Side Street	Residential Only Buildings: Not Allowed/Allowed All Other: Allowed/Allowed		
	Surface Parking Screening Required	Section 10.5.4.4		
	Vehicle Access, 3 or more side-by-side dwelling units in one structure	From Alley; or Street access allowed when no Alley present See Section 9.7.7.6.		
	Vehicle Access, all other permitted uses	Access determined as part of Site Development Plan Review		

<b>DESIGN ELEMENTS</b>		M-RX-3	M-RX-5	M-RX-5A*
<b>CONFIGURATION</b>				
G	Upper Story Setback Above 27', adjacent to Protected District, Rear, alley/Rear, no alley and Side Interior (min)	15'/20'/25'	15'/20'/25'	15'/20'/25'
H	Upper Story Setback Above 51', adjacent to Protected District, Rear, alley/Rear, no alley and Side Interior (min)	na	30'/35'/40'	30'/35'/40'
I	Upper Story Setback Above 70', adjacent to Protected District, Rear, alley/Rear, no alley and Side Interior (min)	na	na	na
<b>STREET LEVEL ACTIVATION</b>				
	Design Criteria	See Section 9.7.5.1		
J	Transparency, Primary Street (min)	40%** Residential Only buildings: 30%**		
K	Transparency, Side Street (min)	25%**		
L	Pedestrian Access, Primary Street	Pedestrian Connection		

<b>USES</b>		M-RX-3, M-RX-5, M-RX-5A
		All permitted Primary Uses shall be allowed within this building form, except Single Unit and Two Unit Dwelling uses ; however: (1) Second Story and Above: Residential or Lodging Accommodations uses only; and (2) Buildings with No Residential or Lodging Accommodation Uses: 10,000 sf GFA max. (See Section 9.7.9, Uses, and Parking)

\* Form is permitted only on corner zone lots where at least one of the intersecting streets is an arterial or collector street, according to the functional street classifications adopted by the Department of Transportation and Infrastructure ("DOTI").

\*\*Applies only to buildings located within 80' of a Primary and/or Side Street.



## GENERAL (2 OF 3)

<b>HEIGHT</b>		<b>M-CC-5</b>	<b>M-MX-5</b>
<b>A</b>	Stories (max)	5	5
<b>A</b>	Feet (max)	70'	70'

<b>SITING</b>		<b>M-CC-5</b>	<b>M-MX-5</b>
<b>SETBACKS</b>			
<b>C</b>	Primary Street (min)	0'	0'
<b>D</b>	Side Street (min)	0'	0'
<b>E</b>	Side, interior (min)	0'	0'
	Side Interior, adjacent to Protected District (min)	10'	10'
<b>F</b>	Rear (min)	0'	0'
	Rear, adjacent to Protected District, where Alley (public or private) abuts a Rear Zone Lot Line (min)	5'	5'
	Rear, adjacent to Protected District, where Alley (public or private) does not abut a Rear Zone Lot Line (min)	10'	10'
<b>PARKING</b>			
	Surface Parking between building and Primary Street / Side Street	Allowed/Allowed	Residential Only Buildings: Not Allowed/Allowed All Other: Allowed/Allowed
	Screening Required		Section 10.5.4.4
	Vehicle Access, 3 or more side-by-side dwelling units in one structure	From Alley; or Street access allowed when no Alley present	Sec. 9.7.7.6
	Vehicle Access, all other permitted uses	Access determined as part of Site Development Plan Review	

<b>DESIGN ELEMENTS</b>		<b>M-CC-5</b>	<b>M-MX-5</b>
<b>CONFIGURATION</b>			
<b>G</b>	Upper Story Setback Above 27', adjacent to Protected District, Rear, alley/Rear, no alley and Side Interior (min)	15'/20'/25'	15'/20'/25'
<b>H</b>	Upper Story Setback Above 51', adjacent to Protected District, Rear, alley/Rear, no alley and Side Interior (min)	30'/35'/40'	30'/35'/40'
<b>I</b>	Upper Story Setback Above 70', adjacent to Protected District, Rear, alley/Rear, no alley and Side Interior (min)	na	na
<b>STREET LEVEL ACTIVATION</b>			
	Design Criteria	See Section 9.7.5.1	See Section 9.7.5.1
		40%**	40%**
<b>J</b>	Transparency , Primary Street (min)	Residential Only buildings: 30%**	Residential Only buildings: 30%**
<b>K</b>	Transparency, Side Street (min)	25%**	25%**
	Transparency Alternatives	See Section 9.7.6.2	
<b>L</b>	Pedestrian Access, Primary Street	Pedestrian Connection	

<b>USES</b>		<b>M-CC-5, M-MX-5</b>
		All permitted Primary Uses allowed within the applicable Zone District, except Single Unit and Two Unit Dwelling uses. See Section 9.7.9, Uses, and Parking

\*\*Applies only to buildings located within 80' of a Primary and/or Side Street.

## GENERAL (3 OF 3)

<b>HEIGHT</b>		<b>M-IMX-5</b>	<b>M-IMX-8</b>	<b>M-IMX-12 M-GMX</b>
<b>A</b>	Stories (max)	5	8	12
<b>A</b>	Feet (max)	70'	100'	140'
	Feet, within 175' of a Protected District (max)	na	75'	75'

<b>SITING</b>		<b>M-IMX-5</b>	<b>M-IMX-8</b>	<b>M-IMX-12 M-GMX</b>
<b>SETBACKS</b>				
<b>C</b>	Primary Street (min)	0'	0'	0'
<b>D</b>	Side Street (min)	0'	0'	0'
<b>E</b>	Side, interior (min)	0'	0'	0'
	Side Interior, adjacent to Protected District (min)	10'	10'	10'
<b>F</b>	Rear (min)	0'	0'	0'
	Rear, adjacent to Protected District, where Alley (public or private) abuts a Rear Zone Lot Line (min)	5'	5'	5'
	Rear, adjacent to Protected District, where Alley (public or private) does not abut a Rear Zone Lot Line	10'	10'	10'
<b>PARKING</b>				
	Surface Parking between building and Primary Street / Side Street	Residential Only Buildings: Not Allowed/Allowed All Other: Allowed/Allowed		
	Screening Required	Section 10.5.4.4		
	Vehicle Access, 3 or more side-by-side dwelling units in one structure	From Alley; or Street access allowed when no Alley present See Sec. 9.7.7.6		
	Vehicle Access, all other permitted uses	Access determined as part of Site Development Plan Review		

<b>DESIGN ELEMENTS</b>		<b>M-IMX-5</b>	<b>M-IMX-8</b>	<b>M-IMX-12 M-GMX</b>
<b>CONFIGURATION</b>				
<b>G</b>	Upper Story Setback Above 27', adjacent to Protected District, Rear, alley/Rear, no alley and Side Interior (min)	15'/20'/25'	15'/20'/25'	15'/20'/25'
<b>H</b>	Upper Story Setback Above 51', adjacent to Protected District, Rear, alley/Rear, no alley and Side Interior (min)	30'/35'/40'	30'/35'/40'	30'/35'/40'
<b>I</b>	Upper Story Setback Above 70', adjacent to Protected District, Rear, alley/Rear, no alley and Side Interior (min)	na	90'/90'/90'	90'/90'/90'
<b>STREET LEVEL ACTIVATION</b>				
	Design Criteria	See Section 9.7.5.1		
<b>J</b>	Transparency, Primary Street (min)	40%** Residential Only buildings: 30%**	40%** Residential Only buildings: 30%**	40%** Residential Only buildings: 30%**
<b>K</b>	Transparency, Side Street (min)	25%**	25%**	25%**
<b>L</b>	Pedestrian Access, Primary Street	Pedestrian Connection		

<b>USES</b>		<b>M-GMX, All M-IMX</b>
		All permitted Primary Uses allowed within the applicable Zone District, except Single Unit and Two Unit Dwelling uses. See Section 9.7.9, <a href="#">Uses</a> , and <a href="#">Parking</a>

\*\*Applies only to buildings located within 80' of a Primary and/or Side Street.

## INDUSTRIAL

<b>HEIGHT</b>		M-IMX-5	M-IMX-8	M-IMX-12 M-GMX
A	Stories (max)	5	8	8
A	Feet (max)	70'	110'	110'
	Feet, within 175' of a Protected District (max)	na	75'	75'

<b>SITING</b>		M-IMX-5	M-IMX-8	M-IMX-12 M-GMX
<b>SETBACKS</b>				
B	Primary Street (min)	20'	20'	20'
C	Side Street (min)	10'	10'	10'
		Can reduce to 5' on lot less than 100ft in width on the long side of the block		
D	Side Interior (min)	0'	0'	0'
	Side Interior adjacent to Protected District (min)	10'	10'	10'
E	Rear (min)	0'	0'	0'
	Rear, adjacent to Protected District (min)	10'	10'	10'
<b>PARKING</b>				
	Primary Street Setback (min)	10'	10'	10'
	Side Street Setback (min)	5'	5'	10'
	Setback adjacent to Protected District (min)	10'	10'	20'

<b>DESIGN ELEMENTS</b>		M-IMX-5	M-IMX-8	M-IMX-12 M-GMX
F	Upper Story Setback Above 27', adjacent to Protected District, alley/ no alley and side, interior (min)	20'/25	20'/25	20'/25
G	Upper Story Setback Above 51', adjacent to Protected District, alley/ no alley and side, interior (min)	35'/40'	35'/40'	35'/40'
	Upper Story Setback Above 70', adjacent to Protected District, Rear, alley/Rear, no alley and Side Interior (min)	na	90'/90'/90'	90'/90'/90'

<b>USES</b>		M-GMX All M-IMX
		Industrial, Manufacturing & Wholesale Primary Uses Only. See Section 9.7.9, <a href="#">Uses</a> , and <a href="#">Parking</a>

BUILDING FEATURES	ZONE DISTRICTS	THE AGGREGATE SHALL NOT EXCEED 33-1/3 PERCENT OF THE AREA OF THE SUPPORTING ROOF	SHALL BE SET BACK FROM THE PERIMETER OF THE BUILDING A MINIMUM OF ONE FOOT HORIZONTALLY FOR EVERY ONE FOOT OF VERTICAL HEIGHT	MAY EXCEED MAXIMUM HEIGHT IN FEET BY:	MAY EXCEED MAXIMUM HEIGHT IN STORIES BY:	MAY PROJECT THROUGH THE BULK PLANE	MAY EXCEED UPPER STORY SETBACK HEIGHT BY:
Parapet Wall or Safety Railing	All 5-Story or greater M-RX, M-CC, M-MX, M-IMX, M-GMX Zone Districts	No	No	Any distance	Not applicable	Not allowed	4'
Solar panels	All M- Zone Districts	No	No	Any distance	Not applicable	Any distance	Any distance
Evaporative coolers	All M- Zone Districts	No	Yes	Any distance	Not applicable	Any distance	Any distance
Accessory water tanks	All M-CC, M-MX, M-IMX, M-GMX Zone Districts	No	Yes	28'	Not applicable	Any distance	Any distance
Pedestrian bridge	All M- Zone Districts	Not applicable	Not applicable	28'	Any number	Any distance	Any distance

### 9.7.7.2 Setback Exceptions - Architectural, Site, Service & Utility Elements

#### A. Intent

To allow minor elements to encroach into a setback while maintaining an open and unobstructed minimum setback.

#### B. Standard

Except as specifically allowed below, Setbacks specified in the applicable Building Form tables shall be open and unobstructed.

#### C. Exceptions

The following Structures or portions of Structures are permitted to encroach into the Setbacks subject to the limitations in the tables below. No portion of a Structure that encroaches into the Setbacks shall extend into a required Setback beyond the maximum Setback encroachment distance specified in the tables below, as measured perpendicular to the respective Zone Lot line. Where more than one Setback encroachment is allowed for the same Structure or portion of a Structure, the permitted Setback encroachment distances shall not be cumulative. See "Height Exceptions" for encroachments related to Upper Story Setbacks.

##### 1. Architectural Elements

To allow for minor elements which add to the architectural character of buildings, while maintaining an open and unobstructed setback.

**2. Site Elements**

To allow for minor screening and parking elements while maintaining an open and unobstructed setback.

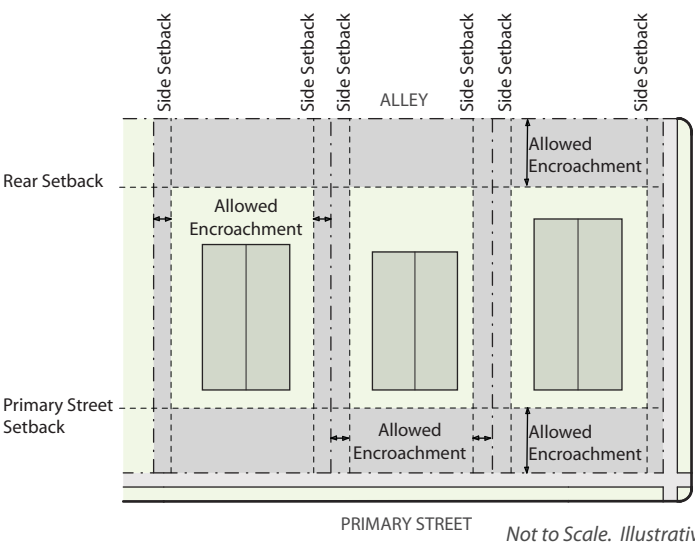
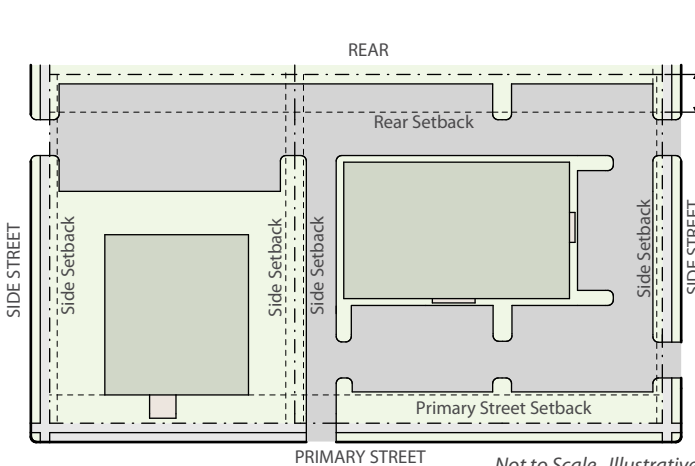
	ZONE DISTRICTS	BUILDING FORMS	PRIMARY STREET	SIDE STREET	SIDE INTERIOR	REAR
Fences and Walls	See Division 10.5 Landscaping, Fences, Walls and Screening					
	ZONE DISTRICTS	BUILDING FORMS	PRIMARY STREET	SIDE STREET	SIDE INTERIOR	REAR
Off-Street Parking Area	All M-RH, M-RX, M-GMX	Suburban House, Urban House, Duplex, and Tandem House	Any distance	Any distance	Any distance	Any distance
Intent: To allow surface parking where it is <b>not less</b> impactful <del>due to the number of required parking spaces.</del>						
	ZONE DISTRICTS	BUILDING FORMS	PRIMARY STREET	SIDE STREET	SIDE INTERIOR	REAR
Off-Street Parking Area	All M-RH, M-RX, M-MX, M-IMX, M-GMX Zone Districts	Garden Court, Town House, Row House, and Apartment	Not allowed	Not allowed	Not allowed	Any distance
Intent: To restrict surface parking where it is <b>more</b> impactful <del>due to the number of required parking spaces.</del>						

	ZONE DISTRICTS	BUILDING FORMS	PRIMARY STREET	SIDE STREET	SIDE INTERIOR	REAR
Drive or Driveway	All M-RH, M-RX, M-GMX Zone Districts	Suburban House, Urban House, Duplex, and Tandem House	Any distance	Any distance	Any distance	Any distance
Intent: To allow a Drive or Driveway to access an Off-Street Parking Area.	<p>The diagram illustrates the setbacks and encroachments for a driveway and parking area. It shows a cross-section of a lot with a driveway leading to an off-street parking area. The lot is bounded by a Primary Street on the bottom and a Side Street on the right. A dashed line indicates the Rear Setback. A dashed line indicates the Primary Street Setback. The diagram shows three building footprints, each with a driveway leading to a parking space. The setbacks are labeled as Side Setback, Rear Setback, and Primary Street Setback. The diagram also shows an ALLEY between the buildings. The allowed encroachments are labeled as Allowed Encroachment. The diagram is labeled as Not to Scale. Illustrative Only.</p>					
	<p><i>Illustrative only</i></p>					

## SECTION 9.7.9 USES ~~AND REQUIRED MINIMUM PARKING~~

### 9.7.9.1 Applicability

- A. This Section 9.7.9 sets forth the land uses permitted, ~~and the~~ required zoning procedures ~~and the required minimum parking~~ for all the Master Planned Context zone districts.
- B. Uses not listed are prohibited, unless the Zoning Administrator specifically permits the unlisted use according to Section 12.4.6, Code Interpretations and Determination of Unlisted Uses.
- C. For number of primary and accessory uses allowed per Zone Lot, see Section 1.2.3.5, Number of Structures and Uses Allowed per Zone Lot.

### 9.7.9.2 Organization

#### A. Organized by Primary, Accessory and Temporary Uses

The Use ~~and Parking~~ Table first presents all primary uses, then all accessory uses, and finally all temporary uses. Primary uses are arranged hierarchically within the table by use classification, category of primary uses, and then by specific use type. Accessory uses are organized by whether such use is accessory to a primary residential use or to a primary nonresidential use. Temporary uses are presented alphabetically ordered in the last division of the table.

#### B. Primary Use Classifications, Categories & Specific Use Types

##### 1. Primary Use Classifications

All primary land uses in the Use ~~and Parking~~ Table are organized into one of the following five general land use classifications:

- a. Residential Uses
- b. Civic, Public & Institutional Uses
- c. Commercial Sales, Service & Repair Uses
- d. Industrial, Manufacturing & Wholesale Uses
- e. Agriculture

##### 2. Primary Use Categories & Specific Use Types

Primary uses are further organized into use categories and specific use types listed under each general primary land use classification. The Use ~~and Parking~~ Table is organized into the above five general land use classifications, use categories and specific use types.

##### 3. Classifications & Categories Are Mutually Exclusive

The general land use classifications and use categories listed in the Use ~~and Parking~~ Table are intended to be mutually exclusive; that is, a use classified into one use category, such as “lodging accommodations,” cannot be classified in a different use category, such as “congregate living,” unless otherwise expressly allowed by this Code.

### 9.7.9.3 Explanation of Table Abbreviations

#### A. General Explanation of Table Cell Entries

In each of the table cells, the entry will indicate first whether use limitations apply to the specific use, and then separated by a hyphen, the type of zoning review required prior to establishment of the use under this Code. For example, as described in more detail below, a cell entry “L-ZPIN” means, first, the use is subject to use limitations (the “L”), and, second, that the use is subject to zoning permit review with information notice (the “ZPIN”) prior to its establishment.

### 9.7.9.4 Enclosure of Uses

All primary, accessory and temporary uses must be established, operated and maintained within a Completely Enclosed Structure, unless otherwise specifically allowed by this Code. The Use ~~and Parking~~ Tables in Articles 3-9 indicate when a use may be established, operated or maintained outside Completely Enclosed Structure by including an asterisk "\*" next to the specific use type. For example, the asterisk following the "Telecommunication Tower\*" use type in the tables indicates that a telecommunication tower land use need not be enclosed.

### 9.7.9.5 District Specific Standards

KEY: \*= Need Not be Enclosed P = Permitted Use without Limitations L = Permitted Use with Limitations NP = Not Permitted Use  
ZP = Zoning Permit Review ZPCIM = Subject to Zoning Permit Review with Community Information Meeting  
ZPIN = Subject to Zoning Permit Review with Informational Notice ZPSE = Subject to Zoning Permit with Special Exception Review  
When no ZP, ZPCIM, ZPIN, ZPSE listed = No Zoning Permit required

USE CATEGORY	SPECIFIC USE TYPE • <del>Vehicle Parking Reqmt: # spaces per unit of measurement</del> • <del>Bicycle Parking Reqmt: # spaces per unit of measurement</del> (% Required Spaces in Enclosed Facility / % Required Spaces in Fixed Facility)						APPLICABLE USE LIMITATIONS  M-RH-3 M-RX-3 M-RX-5 M-CC-5 M-MX-5 M-IMX-5 M-IMX-8 M-IMX-12 M-GMX
		M-RH-3	M-RX-5A	M-CC-5	M-MX-5	M-IMX-5	
<b>RESIDENTIAL PRIMARY USE CLASSIFICATION</b>							
Household Living	Dwelling, Single Unit • <del>No Parking Requirements</del>	L-ZP	L-ZP	L-ZP	L-ZP	L-ZP	§11.2.7
	Dwelling, Two Unit • <del>Vehicle: 1/unit</del> • <del>Bicycle: No requirement</del>	L-ZP	L-ZP	L-ZP	L-ZP	L-ZP	§11.2.7
	Dwelling, Multi-Unit • <del>Vehicle: 1/unit</del> • <del>Bicycle: 1/4 units (80/20)</del>	L-ZP	L-ZP	L-ZP	L-ZP	L-ZP	§11.2.7
	Dwelling, Live / Work • <del>Vehicle: 1/unit</del> • <del>Bicycle: 1/4 units (80/20)</del>	L-ZP	L-ZP	L-ZP	L-ZP	L-ZP	§ 11.2.4, §11.2.7
	Manufactured Home Community	NP	NP	NP	NP	NP	
Residential Care	Residential Care, Type 1 • <del>Vehicle: .25/1,000 sf GFA</del> • <del>Bicycle: No requirement</del>	L/L-ZP	L/L-ZP	L/L-ZP	L/L-ZP	L/L-ZP	§11.2.8; §11.2.9
	Residential Care, Type 2 • <del>Vehicle: .25/1,000 sf GFA</del> • <del>Bicycle: No requirement</del>	L-ZPCIM	L-ZPCIM	L-ZPCIM	L-ZPCIM	L-ZPCIM	§11.2.8; §11.2.10
	Residential Care, Type 3 • <del>Vehicle: .25/1,000 sf GFA</del> • <del>Bicycle: No requirement</del>	NP	L-ZPCIM	L-ZPCIM	L-ZPCIM	L-ZPCIM	§11.2.8; §11.2.11
	Residential Care, Type 4 • <del>Vehicle: .25/1,000 sf GFA</del> • <del>Bicycle: No requirement</del>	NP	L-ZPCIM	L-ZPCIM	L-ZPCIM	L-ZPCIM	§11.2.8; §11.2.12
Congregate Living	All Types • <del>Vehicle: .5/1,000 sf GFA</del> • <del>Bicycle: 1/20,000 sf GFA</del>	P-ZP	P-ZP	P-ZP	P-ZP	P-ZP	



KEY: \*= Need Not be Enclosed P = Permitted Use without Limitations L = Permitted Use with Limitations NP = Not Permitted Use  
ZP = Zoning Permit Review ZPCIM = Subject to Zoning Permit Review with Community Information Meeting  
ZPIN = Subject to Zoning Permit Review with Informational Notice ZPSE = Subject to Zoning Permit with Special Exception Review  
When no ZP, ZPCIM, ZPIN, ZPSE listed = No Zoning Permit required

USE CATEGORY	SPECIFIC USE TYPE <ul style="list-style-type: none"> <li>• <del>Vehicle Parking Reqmt: # spaces per unit of measurement</del></li> <li>• <del>Bicycle Parking Reqmt: # spaces per unit of measurement</del></li> <li>• <del>(% Required Spaces in Enclosed Facility / % Required Spaces in Fixed Facility)</del></li> </ul>						APPLICABLE USE LIMITATIONS
		M-RH-3	M-RX-3 M-RX-5 M-RX-5A	M-CC-5	M-MX-5	M-IMX-5 M-IMX-8 M-IMX-12 M-GMX	
<b>CIVIC, PUBLIC &amp; INSTITUTIONAL PRIMARY USE CLASSIFICATION</b>							
Basic Utilities	Utility, Major Impact* <ul style="list-style-type: none"> <li>• <del>Vehicle: .5/1,000 s.f. GFA</del></li> <li>• <del>Bicycle: No requirement</del></li> </ul>	L-ZPSE	L-ZPSE	L-ZPSE	L-ZPSE	P-ZPSE	§ 11.3.1
	Utility, Minor Impact* <ul style="list-style-type: none"> <li>• <del>Vehicle: .5/1,000 s.f. GFA</del></li> <li>• <del>Bicycle: No requirement</del></li> </ul>	L-ZP	L-ZP	L-ZP	L-ZP	L-ZP	§ 11.3.2
Community/ Public Services	Community Center* <ul style="list-style-type: none"> <li>• <del>Vehicle: .5/1,000 s.f. GFA</del></li> <li>• <del>Bicycle: 1/10,000 s.f. GFA (0/100)</del></li> </ul>	L-ZP	L-ZP	L-ZP	L-ZP	P-ZP	§ 11.3.3
	Day Care Center <ul style="list-style-type: none"> <li>• <del>Vehicle: 1/1,000 s.f. GFA</del></li> <li>• <del>Bicycle: 1/10,000 s.f. GFA (0/100)</del></li> </ul>	P-ZP	P-ZP	P-ZP	P-ZP	P-ZP	
	Postal Facility, Neighborhood <ul style="list-style-type: none"> <li>• <del>Vehicle: 1.875/1,000 s.f. GFA</del></li> <li>• <del>Bicycle: 1/10,000 s.f. GFA (60/40)</del></li> </ul>	P-ZP	P-ZP	P-ZP	P-ZP	P-ZP	
	Postal Processing Center <ul style="list-style-type: none"> <li>• <del>Vehicle: 1/1,000 s.f. GFA</del></li> <li>• <del>Bicycle: 1/10,000 s.f. GFA (0/100)</del></li> </ul>	NP	P-ZP	P-ZP	P-ZP	P-ZP	
	Public Safety Facility <ul style="list-style-type: none"> <li>• <del>Vehicle: 1/1,000 s.f. GFA</del></li> <li>• <del>Bicycle: 1/10,000 s.f. GFA (0/100)</del></li> </ul>	L-ZP	L-ZP	P-ZP	P-ZP	P-ZP	§ 11.3.5
	Hospital	NP	NP	NP	NP	NP	
	Correctional Institution	NP	NP	NP	NP	NP	
Cultural/Special Purpose/Public Parks & Open Space	Cemetery*	NP	NP	NP	NP	NP	
	Library <ul style="list-style-type: none"> <li>• <del>Vehicle: 1/1,000 s.f. GFA</del></li> <li>• <del>Bicycle: 1/10,000 s.f. GFA (0/100)</del></li> </ul>	P-ZP	P-ZP	P-ZP	P-ZP	P-ZP	
	Museum <ul style="list-style-type: none"> <li>• <del>Vehicle: 1/1,000 s.f. GFA</del></li> <li>• <del>Bicycle: 1/10,000 s.f. GFA (0/100)</del></li> </ul>	NP	P-ZP	P-ZP	P-ZP	P-ZP	
	City Park*	NP	NP	NP	NP	NP	
	Open Space - Conservation* <ul style="list-style-type: none"> <li>• <del>No Parking Requirements</del></li> </ul>	P-ZP	P-ZP	P-ZP	P-ZP	P-ZP	
Education	Elementary or Secondary School <ul style="list-style-type: none"> <li>• <del>Vehicle: 1/1,000 s.f. GFA</del></li> <li>• <del>Bicycle: 1/10,000 s.f. GFA (0/100)</del></li> </ul>	L-ZP	L-ZP	L-ZP	L-ZP	L-ZP	§ 11.3.8
	University or College <ul style="list-style-type: none"> <li>• <del>Vehicle: 1/1,000 s.f. GFA</del></li> <li>• <del>Bicycle: 1/10,000 s.f. GFA (0/100)</del></li> </ul>	NP	L-ZP	L-ZP	L-ZP	L-ZP	§ 11.3.8
	Vocational or Professional School <ul style="list-style-type: none"> <li>• <del>Vehicle: 1/1,000 s.f. GFA</del></li> <li>• <del>Bicycle: 1/10,000 s.f. GFA (0/100)</del></li> </ul>	NP	L-ZP	L-ZP	L-ZP	L-ZP	§ 11.3.8
Public and Religious Assembly	All Types <ul style="list-style-type: none"> <li>• <del>Vehicle: .5/1,000 s.f. GFA</del></li> <li>• <del>Bicycle: 1/10,000 s.f. GFA (0/100)</del></li> </ul>	L-ZP	L-ZP	P-ZP	P-ZP	P-ZP	§ 11.3.10

KEY: \* = Need Not be Enclosed P = Permitted Use without Limitations L = Permitted Use with Limitations NP = Not Permitted Use  
 ZP = Zoning Permit Review ZPCIM = Subject to Zoning Permit Review with Community Information Meeting  
 ZPIN = Subject to Zoning Permit Review with Informational Notice ZPSE = Subject to Zoning Permit with Special Exception Review  
 When no ZP, ZPCIM, ZPIN, ZPSE listed = No Zoning Permit required

USE CATEGORY	SPECIFIC USE TYPE <ul style="list-style-type: none"> <li>• <del>Vehicle Parking Reqmt: # spaces per unit of measurement</del></li> <li>• <del>Bicycle Parking Reqmt: # spaces per unit of measurement</del></li> <li>• <del>(% Required Spaces in Enclosed Facility / % Required Spaces in Fixed Facility)</del></li> </ul>						APPLICABLE USE LIMITATIONS
		M-RH-3	M-RX-3 M-RX-5 M-RX-5A	M-CC-5	M-MX-5	M-IMX-5 M-IMX-8 M-IMX-12 M-GMX	
<b>COMMERCIAL SALES, SERVICES, &amp; REPAIR PRIMARY USE CLASSIFICATION</b>							
Adult Business	All Types	NP	NP	NP	NP	NP	See Section 9.4.4, Use Overlay Districts, for adult business use allowance in the UO-1 District.
Arts, Recreation & Entertainment	Arts, Recreation and Entertainment Services, Indoor <ul style="list-style-type: none"> <li>• <del>Vehicle – Artist Studio: 0.3/1000 s.f. GFA</del></li> <li>• <del>Vehicle – All Others: 1.875/1,000 s.f. GFA</del></li> <li>• <del>Bicycle: 1/10,000 s.f. GFA (60/40)</del></li> </ul>	NP	P-ZP	P-ZP	P-ZP	P-ZP	
	Arts, Recreation and Entertainment Services, Outdoor* <ul style="list-style-type: none"> <li>• <del>Vehicle: 1.875/1,000 s.f. GFA</del></li> <li>• <del>Bicycle: 1/10,000 s.f. GFA (60/40)</del></li> </ul>	NP	L-ZP	L-ZP	L-ZPIN	L-ZP	§ 11.4.3
	Event Space with Alternate Parking and Loading* <ul style="list-style-type: none"> <li>• <del>Vehicle: No requirement</del></li> <li>• <del>Bicycle: No requirement</del></li> </ul>	NP	NP	NP	NP	NP	
	Sports and/or Entertainment Arena or Stadium*	NP	NP	NP	NP	L-ZP	§11.4.5.1
Nonresidential Uses in Existing Business Structures In Residential Zones)		NP	NP	not applicable			
Parking of Vehicles	Parking, Garage <ul style="list-style-type: none"> <li>• <del>No Parking Requirements</del></li> </ul>	NP	P-ZP	P-ZP	P-ZP	P-ZP	
	Parking, Surface* <ul style="list-style-type: none"> <li>• <del>No Parking Requirements</del></li> </ul>	L-ZP	P-ZP	P-ZP	NP	P-ZP	§ 11.4.8
Eating & Drinking Establishments	All Types <ul style="list-style-type: none"> <li>• <del>Vehicle: 3.75/1,000 s.f. GFA</del></li> <li>• <del>Bicycle: 1/3,000 s.f. GFA (0/100)</del></li> </ul>	NP	P-ZP	P-ZP	P-ZP	P-ZP	
Lodging Accommodations	Bed and Breakfast Lodging <ul style="list-style-type: none"> <li>• <del>Vehicle: 1/guest room or unit</del></li> <li>• <del>Bicycle: 1/10,000 s.f. GFA (60/40)</del></li> </ul>	NP	P-ZP	P-ZP	P-ZP	P-ZP	
	Lodging Accommodations, All Others <ul style="list-style-type: none"> <li>• <del>Vehicle: 1/guest room or unit</del></li> <li>• <del>Bicycle: 1/10,000 s.f. GFA (60/40)</del></li> </ul>	NP	P-ZP	P-ZP	P-ZP	P-ZP	
Office	Dental / Medical Office or Clinic <ul style="list-style-type: none"> <li>• <del>Vehicle: 1.875/1,000 s.f. GFA</del></li> <li>• <del>Bicycle: 1/10,000 s.f. GFA (60/40)</del></li> </ul>	NP	L-ZP	L-ZP	L-ZP	L-ZP	§ 11.4.10
	Office, All Others <ul style="list-style-type: none"> <li>• <del>Vehicle: 1.875/1,000 s.f. GFA</del></li> <li>• <del>Bicycle: 1/10,000 s.f. GFA (60/40)</del></li> </ul>	NP	P-ZP	P-ZP	P-ZP	P-ZP	

KEY: \*= Need Not be Enclosed P = Permitted Use without Limitations L = Permitted Use with Limitations NP = Not Permitted Use  
ZP = Zoning Permit Review ZPCIM = Subject to Zoning Permit Review with Community Information Meeting  
ZPIN = Subject to Zoning Permit Review with Informational Notice ZPSE = Subject to Zoning Permit with Special Exception Review  
When no ZP, ZPCIM, ZPIN, ZPSE listed = No Zoning Permit required

USE CATEGORY	SPECIFIC USE TYPE <ul style="list-style-type: none"> <li>• <del>Vehicle Parking Reqmt- # spaces per unit of measurement</del></li> <li>• <del>Bicycle Parking Reqmt- # spaces per unit of measurement</del></li> <li>• <del>(% Required Spaces in Enclosed Facility- % Required Spaces in Fixed Facility)</del></li> </ul>						APPLICABLE USE LIMITATIONS
		M-RH-3	M-RX-3 M-RX-5 M-RX-5A	M-CC-5	M-MX-5	M-IMX-5 M-IMX-8 M-IMX-12 M-GMX	
Retail Sales, Service & Repair (Not Including Vehicle or Equipment Sales, Service & Repair)	Animal Sales and Services, Household Pets Only <ul style="list-style-type: none"> <li>• <del>Vehicle: 1.875/1,000 s.f. GFA</del></li> <li>• <del>Bicycle: 1/10,000 s.f. GFA (60/40)</del></li> </ul>	NP	L-ZP	L-ZP	L-ZP	L-ZP	§ 11.4.12
	Animal Sales and Services, All Others <ul style="list-style-type: none"> <li>• <del>Vehicle: 1.875/1,000 s.f. GFA</del></li> <li>• <del>Bicycle: 1/20,000 s.f. GFA (60/40)</del></li> </ul>	NP	NP	NP	NP	L-ZP	§ 11.4.13.1
	Food Sales or Market <ul style="list-style-type: none"> <li>• <del>Vehicle: 1.875/1,000 s.f. GFA</del></li> <li>• <del>Bicycle: 1/10,000 s.f. GFA (60/40)</del></li> </ul>	NP	L-ZP	P-ZP	P-ZP	P-ZP	§ 11.4.14
	Pawn Shop	NP	NP	NP	NP	NP	
	Retail Sales, Service & Repair -- Outdoor* <ul style="list-style-type: none"> <li>• <del>Vehicle: 1.875/1,000 s.f. GFA</del></li> <li>• <del>Bicycle: 1/10,000 s.f. GFA (60/40)</del></li> </ul>	NP	NP	NP	NP	L-ZP	§ 11.4.16
	Retail Sales, Service & Repair - Firearms Sales <ul style="list-style-type: none"> <li>• <del>Vehicle: 1.875/1,000 s.f. GFA</del></li> <li>• <del>Bicycle: 1/10,000 s.f. GFA (60/40)</del></li> </ul>	NP	NP	P-ZP	NP	P-ZP	
	Retail Sales, Service & Repair, All Others <ul style="list-style-type: none"> <li>• <del>Vehicle: 1.875/1,000 s.f. GFA</del></li> <li>• <del>Bicycle: 1/10,000 s.f. GFA (60/40)</del></li> </ul>	NP	P-ZP	P-ZP	P-ZP	P-ZP	
Vehicle / Equipment Sales, Rentals, Service & Repair	Automobile Emissions Inspection Facility <ul style="list-style-type: none"> <li>• <del>Vehicle: .5/1,000 s.f. GFA</del></li> <li>• <del>Bicycle: No requirement</del></li> </ul>	NP	NP	NP	NP	P-ZP	
	Automobile Services, Light <ul style="list-style-type: none"> <li>• <del>Vehicle: .5/1,000 s.f. GFA</del></li> <li>• <del>Bicycle: No requirement</del></li> </ul>	NP	L-ZP	L-ZP	L-ZP	L-ZP	§ 11.4.18; § 11.4.19
	Automobile Services, Heavy <ul style="list-style-type: none"> <li>• <del>Vehicle: .5/1,000 s.f. GFA</del></li> <li>• <del>Bicycle: No requirement</del></li> </ul>	NP	NP	L-ZP/ZPSE	NP	L-ZP/ZPSE	§ 11.4.18; § 11.4.20
	Automobile / Motorcycle / Light Truck Sales, Rentals, Leasing; Pawn Lot or Vehicle Auctioneer* <ul style="list-style-type: none"> <li>• <del>Vehicle: .5/1,000 s.f. GFA</del></li> <li>• <del>Bicycle: No requirement</del></li> </ul>	NP	L-ZP	L-ZP	L-ZP	L-ZP	§ 11.4.21
	Heavy Vehicle/ Equipment Sales, Rentals & Service* <ul style="list-style-type: none"> <li>• <del>Vehicle: .5/1,000 s.f. GFA</del></li> <li>• <del>Bicycle: No requirement</del></li> </ul>	NP	NP	P-ZPSE	NP	L-ZP	§ 11.4.22
Communications and Information	Antennas Not Attached to a Tower* <ul style="list-style-type: none"> <li>• <del>No Parking Requirements</del></li> </ul>	L-ZP	L-ZP	L-ZP	L-ZP	L-ZP	§ 11.5.2
	Communication Services <ul style="list-style-type: none"> <li>• <del>Vehicle: .5/1,000 s.f. GFA</del></li> <li>• <del>Bicycle: No requirement</del></li> </ul>	NP	L-ZPSE P-ZP	L-ZPSE P-ZP	L-ZPSE P-ZP	P-ZP	§ 11.5.1
	Telecommunications Towers* <ul style="list-style-type: none"> <li>• <del>No Parking Requirements</del></li> </ul>	L-ZP/ ZPIN/ ZPSE	L-ZP/ZPIN/ ZPSE	L-ZP/ZPIN/ ZPSE	L-ZP/ZPIN/ ZPSE	L-ZP/ZPIN/ ZPSE	§ 11.5.2
	Telecommunications Tower - Alternative Structure* <ul style="list-style-type: none"> <li>• <del>No Parking Requirements</del></li> </ul>	L-ZP/ ZPIN	L-ZP/ZPIN	L-ZP/ZPIN	L-ZP/ZPIN	L-ZP/ZPIN	§ 11.5.2
	Telecommunication Facilities -- All Others* <ul style="list-style-type: none"> <li>• <del>No Parking Requirements</del></li> </ul>	L-ZPIN	L-ZPIN	L-ZPIN	L-ZPIN	L-ZPIN	§ 11.5.2

KEY: \*= Need Not be Enclosed P = Permitted Use without Limitations L = Permitted Use with Limitations NP = Not Permitted Use  
 ZP = Zoning Permit Review ZPCIM = Subject to Zoning Permit Review with Community Information Meeting  
 ZPIN = Subject to Zoning Permit Review with Informational Notice ZPSE = Subject to Zoning Permit with Special Exception Review  
 When no ZP, ZPCIM, ZPIN, ZPSE listed = No Zoning Permit required

USE CATEGORY	SPECIFIC USE TYPE <ul style="list-style-type: none"> <li>• <del>Vehicle Parking Reqmt: # spaces per unit of measurement</del></li> <li>• <del>Bicycle Parking Reqmt: # spaces per unit of measurement</del></li> <li>• <del>(% Required Spaces in Enclosed Facility / % Required Spaces in Fixed Facility)</del></li> </ul>						APPLICABLE USE LIMITATIONS
		M-RH-3	M-RX-3 M-RX-5 M-RX-5A	M-CC-5	M-MX-5	M-IMX-5 M-IMX-8 M-IMX-12 M-GMX	
Industrial Services	Contractors, Special Trade - General • <del>Vehicle: .5 / 1,000 s.f. GFA</del> • <del>Bicycle: No requirement</del>	NP	NP	L-ZP	L-ZP	L-ZP	§ 11.5.3.
	Contractors, Special Trade - Heavy/ Contractor Yard*	NP	NP	NP	NP	L-ZP	§ 11.5.4.1
	Food Preparation and Sales, Commer- cial • <del>Vehicle: .5 / 1,000 s.f. GFA</del> • <del>Bicycle: No requirement</del>	NP	L-ZP	L-ZP	L-ZP	L-ZP	§ 11.5.5
	Laboratory, Research, Development and Technological Services • <del>Vehicle: .5 / 1,000 s.f. GFA</del> • <del>Bicycle: No requirement</del>	NP	NP	L-ZP	L-ZP	L-ZP	§ 11.5.6
	Service/Repair, Commercial • <del>Vehicle: .5 / 1,000 s.f. GFA</del> • <del>Bicycle: No requirement</del>	NP	NP	L-ZP	L-ZP	L-ZP	§ 11.5.7
Manufacturing and Production	Manufacturing, Fabrication & Assembly -- Custom • <del>Vehicle: .5 / 1,000 s.f. GFA</del> • <del>Bicycle: No requirement</del>	NP	L-ZPIN	L-ZP	L-ZP	L-ZP	§ 11.5.8
	Manufacturing, Fabrication & Assembly -- General • <del>Vehicle: .5 / 1,000 s.f. GFA</del> • <del>Bicycle: No requirement</del>	NP	NP	L-ZP/ZPSE	L-ZP/ZPSE	L-ZP/ZPSE	§ 11.5.9
	Manufacturing, Fabrication & Assembly -- Heavy	NP	NP	NP	NP	NP	
Mining & Extraction and Energy Producing Systems	Oil, Gas -- Production, Drilling*	NP	NP	NP	NP	L-ZP	§ 11.5.10.1
	Sand or Gravel Quarry*	NP	NP	NP	NP	L-ZP	§ 11.5.11.1
	Wind Energy Conversion Systems* • <del>No Parking Requirements</del>	L-ZPIN/ ZPSE	L-ZPIN/ ZPSE	L-ZPIN/ ZPSE	L-ZPIN/ ZPSE	L-ZPIN/ZPSE	§ 11.5.13
Transportation Facilities	Airport*	NP	NP	NP	NP	NP	
	Helipad, Helistop, Heliport* • <del>No Parking Requirements</del>	L-ZPIN	L-ZPIN	L-ZP	L-ZP	L-ZP	§ 11.5.14
	Railroad Facilities*	NP	NP	NP	NP	P-ZP	
	Railway Right-of-Way* • <del>No Parking Requirements</del>	P-ZP	P-ZP	P-ZP	P-ZP	P-ZP	
	Terminal, Station or Service Facility for Passenger Transit System • <del>Vehicle: .5 / 1,000 s.f. GFA</del> • <del>Bicycle: No requirement</del>	L-ZP	P-ZP	P-ZP	P-ZP	P-ZP	§ 11.5.15
Terminal, Freight, Air Courier Services	NP	NP	NP	NP	L-ZP	§ 11.5.16.1	
Waste Related Services	Automobile Parts Recycling Business*	NP	NP	NP	NP	NP	
	Junkyard*	NP	NP	NP	NP	NP	
	Recycling Center	NP	NP	NP	NP	L-ZPIN	§ 11.5.19.1
	Recycling Collection Station	NP	NP	NP	NP	P-ZP	
	Recycling Plant, Scrap Processor	NP	NP	NP	NP	NP	
Solid Waste Facility	NP	NP	NP	NP	NP		

KEY: \*= Need Not be Enclosed P = Permitted Use without Limitations L = Permitted Use with Limitations NP = Not Permitted Use  
ZP = Zoning Permit Review ZPCIM = Subject to Zoning Permit Review with Community Information Meeting  
ZPIN = Subject to Zoning Permit Review with Informational Notice ZPSE = Subject to Zoning Permit with Special Exception Review  
When no ZP, ZPCIM, ZPIN, ZPSE listed = No Zoning Permit required

USE CATEGORY	SPECIFIC USE TYPE <ul style="list-style-type: none"> <li>• <del>Vehicle Parking Reqmt: # spaces per unit of measurement</del></li> <li>• <del>Bicycle Parking Reqmt: # spaces per unit of measurement</del></li> <li>• <del>(% Required Spaces in Enclosed Facility / % Required Spaces in Fixed Facility)</del></li> </ul>						APPLICABLE USE LIMITATIONS
		M-RH-3	M-RX-3 M-RX-5 M-RX-5A	M-CC-5	M-MX-5	M-IMX-5 M-IMX-8 M-IMX-12 M-GMX	
Wholesale, Storage, Warehouse & Distribution	Automobile Towing Service Storage Yard*	NP	NP	NP	NP	NP	
	Mini-storage Facility <ul style="list-style-type: none"> <li>• <del>Vehicle: 0.1 / 1,000 s.f. GFA</del></li> <li>• <del>Bicycle: No requirement</del></li> </ul>	NP	NP	P-ZP	L-ZP	P-ZP	§ 11.5.23
	Vehicle Storage, Commercial*	NP	NP	NP	NP	NP	
Wholesale, Storage, Warehouse & Distribution	Wholesale Trade or Storage, General <ul style="list-style-type: none"> <li>• <del>Vehicle: .5 / 1,000 s.f. GFA</del></li> <li>• <del>Bicycle: No requirement</del></li> </ul>	NP	NP	P-ZPIN	NP	P-ZP	
	Wholesale Trade or Storage, Light <ul style="list-style-type: none"> <li>• <del>Vehicle: .5 / 1,000 s.f. GFA</del></li> <li>• <del>Bicycle: No requirement</del></li> </ul>	NP	NP	L-ZP/ZPIN/ ZPSE	L-ZP/ZPIN/ ZPSE	P-ZP/ZPIN/ZPSE	§ 11.5.26
<b>AGRICULTURE PRIMARY USE CLASSIFICATION</b>							
Agriculture	Aquaculture*	NP	NP	NP	NP	L-ZP	§11.6.1
	Garden, Urban* <ul style="list-style-type: none"> <li>• <del>Vehicle: .5 / 1,000 s.f. GFA</del></li> <li>• <del>Bicycle: No requirement</del></li> </ul>	L-ZP	L-ZP	L-ZP	L-ZP	L-ZP	§11.6.2
	Husbandry, Animal*	NP	NP	NP	NP	NP	
	Husbandry, Plant*	NP	NP	NP	NP	NP	
	Plant Nursery <ul style="list-style-type: none"> <li>• <del>Vehicle: .5 / 1,000 s.f. GFA</del></li> <li>• <del>Bicycle: No requirement</del></li> </ul>	NP	L-ZP	L-ZP	L-ZP	L-ZP*	§11.6.5

KEY: \*= Need Not be Enclosed P = Permitted Use without Limitations L = Permitted Use with Limitations NP = Not Permitted Use  
ZP = Zoning Permit Review ZPCIM = Subject to Zoning Permit Review with Community Information Meeting  
ZPIN = Subject to Zoning Permit Review with Informational Notice ZPSE = Subject to Zoning Permit with Special Exception Review  
When no ZP, ZPCIM, ZPIN, ZPSE listed = No Zoning Permit required

USE CATEGORY	SPECIFIC USE TYPE						APPLICABLE USE LIMITATIONS
	<ul style="list-style-type: none"> <li><del>Vehicle Parking Reqmt- # spaces per unit of measurement</del></li> <li><del>Bicycle Parking Reqmt- # spaces per unit of measurement</del></li> <li><del>(% Required Spaces in Enclosed Facility- % Required Spaces in Fixed Facility)</del></li> </ul>	M-RH-3	M-RX-3 M-RX-5 M-RX-5A	M-CC-5	M-MX-5	M-IMX-5 M-IMX-8 M-IMX-12 M-GMX	
<b>ACCESSORY TO PRIMARY RESIDENTIAL USES USE CLASSIFICATION</b>							
Accessory to Primary Residential Uses  (Parking is Not Required for Accessory Uses Unless Specifically Stated in this Table or in an Applicable Use Limitation)	Unlisted Accessory Uses	L - Applicable in all Zone Districts					§11.7
	Accessory Dwelling Unit	L-ZP	L-ZP	L-ZP	L-ZP	L-ZP	§ 11.7; § 11.8.2
	Domestic Employee	L	L	L	L	L	§ 11.7; § 11.8.3
	Garden*	L	L	L	L	L	§ 11.7; § 11.8.4
	Keeping of Household Animals*	L / L-ZPIN	L / L-ZPIN	L / L-ZPIN	L / L-ZPIN	L / L-ZPIN	§ 11.7; § 11.8.5
	Keeping and Off-Street Parking of Vehicles, Motorcycles, Trailers & Recreational Vehicles*	L	L	L	L	L	§ 11.7; § 10.9
	kennel or Exercise Run*	L	L	L	L	L	§ 11.7; § 11.8.6
	Limited Commercial Sales, Services Accessory to Multi-Unit Dwelling Use	NP	L-ZP	Not Applicable - See Permitted Primary Uses			§ 11.7; § 11.8.7
	Outdoor Storage, Residential*	L	L	L	L	L	§11.7; §11.8.8
	Second Kitchen Accessory to Single Unit Dwelling Use	L-ZP	L-ZP	L-ZP	L-ZP	NP	§ 11.7; § 11.8.9
	Short-term Rental	L	L	L	L	L	§ 11.7; § 11.8.10
	Vehicle Storage, Repair and Maintenance*	L	L	L	L	L	§ 11.7; § 10.9
	Wind Energy Conversion Systems*	L-ZPIN/ ZPSE	L-ZPIN/ ZPSE	Not Applicable - See Permitted Primary Uses			§ 11.7; § 11.5.13
Yard or Garage Sales*	L	L	L	L	L	§ 11.7; § 11.8.11	
<b>HOME OCCUPATIONS ACCESSORY TO PRIMARY RESIDENTIAL USES USE CLASSIFICATION</b>							
Home Occupations  (Parking is Not Required for Home Occupations Unless Specifically Stated in this Table or in an Applicable Use Limitation)	Child Care Home, Large	L-ZP	L-ZP	L-ZP	L-ZP	L-ZP	§ 11.9; §11.9.3
	All Other Types	L-ZP	L-ZP	L-ZP	L-ZP	L-ZP	§ 11.9; § 11.9.4
	Unlisted Home Occupations	L-ZPIN	L-ZPIN	L-ZPIN	L-ZPIN	L-ZPIN	§ 11.9; § 11.9.5

KEY: \*= Need Not be Enclosed P = Permitted Use without Limitations L = Permitted Use with Limitations NP = Not Permitted Use  
ZP = Zoning Permit Review ZPCIM = Subject to Zoning Permit Review with Community Information Meeting  
ZPIN = Subject to Zoning Permit Review with Informational Notice ZPSE = Subject to Zoning Permit with Special Exception Review  
When no ZP, ZPCIM, ZPIN, ZPSE listed = No Zoning Permit required

USE CATEGORY	SPECIFIC USE TYPE	APPLICABLE USE LIMITATIONS					
	<ul style="list-style-type: none"> <li>• <del>Vehicle Parking Reqmt- # spaces per unit of measurement</del></li> <li>• <del>Bicycle Parking Reqmt- # spaces per unit of measurement</del></li> <li>• <del>(% Required Spaces in Enclosed Facility-% Required Spaces in Fixed Facility)</del></li> </ul>	M-RH-3	M-RX-3 M-RX-5 M-RX-5A	M-CC-5	M-MX-5	M-IMX-5 M-IMX-8 M-IMX-12 M-GMX	
ACCESSORY TO PRIMARY NONRESIDENTIAL USES USE CLASSIFICATION							
Accessory to Primary Nonresidential Uses  (Parking is Not Required for Accessory Uses Unless Specifically Stated in this Table or in an Applicable Use Limitation)	Unlisted Accessory Uses	L - Applicable in all Zone Districts					§11.7; §11.10.1
	Amusement Devices Accessory to Eating/Drinking Establishments, College/University and Theater Uses	NP	L-ZP	L-ZP	L-ZP	L-ZP	§ 11.7; § 11.10.2
	Automobile Rental Services Accessory to Certain Retail Uses*	NP	Not Applicable - See Primary Uses				§ 11.7; § 11.10.3
	Book or gift store; media recording and production facilities accessory to public libraries, museums, places of religious assembly, colleges or universities	L	Not Applicable - See Permitted Primary Uses				§ 11.7; § 11.10.4
	Car Wash Bay Accessory to Automobile Services	NP	NP	L-ZP	L-ZP	L-ZP	§ 11.7; § 11.10.5
	College Accessory to a Place for Religious Assembly	L	Not Applicable - See Permitted Primary Uses				§ 11.7; § 11.10.6
	Conference Facilities Accessory to Hotel Use	NP	L	L	L	L	§ 11.7; § 11.10.7
	Drive Through Facility Accessory to Eating/Drinking Establishments and to Retail Sales, Service, and Repair Uses*	NP	NP	L-ZP	L-ZP	L-ZP	§ 11.7; § 11.10.8
	Emergency Vehicle Access Point	NP	NP	NP	NP	NP	
	Garden*	L	L	L	L	L	§11.7; §11.10.10
	Keeping of Animals	L/L-ZPIN	L/L-ZPIN	L/L-ZP/ L-ZPIN	L/L-ZP/ L-ZPIN	L/L-ZP/ L-ZPIN	§11.7; § 11.10.11
	Limited Commercial Sales, Services	L	L	L	L	L	§11.7; §11.10.12
	Nonresidential Uses in Existing Business Structures In Residential Zones - Accessory Uses	NP	Not Applicable - See Permitted Primary Uses	Not Applicable			
	Occasional Sales, Services Accessory to Primary Places of Religious Assembly or Primary Uses Operated by Nonprofit Organizations*	L	L	L	L	L	§11.7; §11.10.13
	Outdoor Gathering Area*	L/L-ZP/ L-ZPIN	L/L-ZP/ L-ZPIN	L/L-ZP/ L-ZPIN	L/L-ZP/ L-ZPIN	L/L-ZP/ L-ZPIN	§11.7; §11.10.14
	Outdoor Entertainment Accessory to an Eating/Drinking Establishment Use*	NP	L-ZPIN/ ZPSE	L-ZPIN/ ZPSE	L-ZPIN/ ZPSE	L-ZPIN/ ZPSE	§11.7; §11.10.15
	Outdoor Retail Sale and Display*	NP	L-ZP/ ZPSE	L-ZP/ ZPSE	L-ZP/ ZPSE	L-ZP/ ZPSE	§11.7; §11.10.16
	Outdoor Storage, General*	NP	NP	NP	NP	M-IMX: NP M-GMX: L-ZP	§11.7; §11.10.17
	Outdoor Storage, Limited*	NP	NP	L-ZP	L-ZP	L-ZP	§11.7; §11.10.18
	Rental or Sales of Adult Material Accessory to a Permitted Bookstore Retail Sales Use	NP	L	L	L	L	§11.7; §11.10.19
Retail Food Establishment, Mobile (Food Truck)*	L-ZP	L-ZP	L-ZP	L-ZP	L-ZP	§11.7; §11.10.20	

KEY: \*= Need Not be Enclosed P = Permitted Use without Limitations L = Permitted Use with Limitations NP = Not Permitted Use  
 ZP = Zoning Permit Review ZPCIM = Subject to Zoning Permit Review with Community Information Meeting  
 ZPIN = Subject to Zoning Permit Review with Informational Notice ZPSE = Subject to Zoning Permit with Special Exception Review  
 When no ZP, ZPCIM, ZPIN, ZPSE listed = No Zoning Permit required

USE CATEGORY	SPECIFIC USE TYPE						APPLICABLE USE LIMITATIONS
	<ul style="list-style-type: none"> <li>• <del>Vehicle Parking Reqmt- # spaces per unit of measurement</del></li> <li>• <del>Bicycle Parking Reqmt- # spaces per unit of measurement</del></li> <li>• <del>(% Required Spaces in Enclosed Facility- % Required Spaces in Fixed Facility)</del></li> </ul>	M-RH-3	M-RX-3 M-RX-5 M-RX-5A	M-CC-5	M-MX-5	M-IMX-5 M-IMX-8 M-IMX-12 M-GMX	

**TEMPORARY USE CLASSIFICATION**

Temporary Uses  (Parking is Not Required for Temporary Uses Unless Specifically Stated in this Table or in an Applicable Use Limitations)	Unlisted Temporary Uses	L - Applicable in all Zone Districts					\$11.11.1
	Ambulance Service - Temporary	NP	L-ZP	Not Applicable - See Permitted Primary Uses			\$11.11.2
Amusement / Entertainment - Temporary*	NP	NP	NP	NP	L-ZP	\$11.11.3	
Bazaar, Carnival, Circus or Special Event*	L-ZP	L-ZP	L-ZP	L-ZP	L-ZP	\$11.11.4	
Building or yard for construction materials*	L-ZP	L-ZP	L-ZP	L-ZP	L-ZP	\$11.11.5	
Concrete, Asphalt, and Rock Crushing Facility*	L-ZP	L-ZP	L-ZP	L-ZP	L-ZP	\$11.11.6	
Fence for Demolition or Construction Work	L-ZP	L-ZP	L-ZP	L-ZP	L-ZP	\$11.11.7	
Health Care Center	L-ZP	L-ZP	P-ZP	P-ZP	P-ZP	\$11.11.8	
Noncommercial Concrete Batching Plant*	L-ZP	L-ZP	L-ZP	L-ZP	L-ZP	\$11.11.9	
Outdoor Retail Sales - Pedestrian / Transit Mall*	NP	NP	NP	NP	L-ZP	\$11.11.10	
Outdoor Retail Sales*	NP	L-ZP	L-ZP	L-ZP	L-ZP	\$11.11.11	
Outdoor Sales, Seasonal*	NP	L-ZPIN	L-ZP	L-ZP	L-ZP	\$11.11.12	
Parking Lot Designated for a Special Event*	L-ZP	L-ZP	L-ZP	L-ZP	L-ZP	\$11.11.13	
Retail Food Establishment, Mobile (Food Truck)**	NP	L/L-ZP	L/L-ZP	L/L-ZP	L/L-ZP	\$11.11.14	
Temporary Construction Office	L-ZP	L-ZP	L-ZP	L-ZP	L-ZP	\$11.11.15	
Temporary Office - Real Estate Sales	L-ZP	L-ZP	L-ZP	L-ZP	L-ZP	\$11.11.16	
Temporary Managed Community*	L-ZPCIM	L-ZPCIM	L-ZPCIM	L-ZPCIM	L-ZPCIM	\$11.11.17	
Tent for Religious Services	NP	NP	NP	NP	L-ZP	\$11.11.18	



## INTRODUCTION TO ARTICLE 10

- A. Article 10, General Design Standards contains general design standards that apply throughout the city and are not unique to a Neighborhood Context or Special Context, including general standards for parking, landscaping, site grading, outdoor lighting, and signs.
- B. Article 10, General Design Standards is comprised of separate Divisions that present all regulations related to a single subject matter. For example, Division 10.4, Parking and Loading includes all regulations related to the provision of off-street parking and loading, including ~~exceptions and exemptions from minimum~~ minimum bicycle parking, maximum vehicle parking, requirements and minimum design for the layout of Off-Street Parking Areas.
- C. All development shall comply with this Article 10's general design standards in addition to compliance with a zone district's more specific building form and design standards, and with applicable use limitations. Each Division in Article 10, General Design Standards includes an applicability provision as to what specific types of development activity trigger application of the Division's standards.

## **DIVISION 10.2 GENERAL SITE DESIGN AND FACILITY STANDARDS**

### **SECTION 10.2.1 INTENT**

This Division's general site design and facility standards are intended to supplement the more specific zone district building and design standards found in Articles 3 through 9 and, consistent with this Code's context-based approach, ensure that new development: (a) Provides adequate on-site facilities to meet the demands of residents, employees, and visitors; (b) Assures and promotes convenient pedestrian and bicycle access to parks, community amenities, and activity or employment centers; and (c) Mitigates the potential for any adverse impacts on surrounding properties and neighborhoods.

### **SECTION 10.2.2 APPLICABILITY**

In addition to compliance with applicable building form and design standards, all development shall comply with the following general site and facility design standards, unless otherwise expressly stated. In case of conflict between an applicable zone district standard or an applicable and more specific building form standard in Articles 3 through 9 and a design standard stated in this Division 10.2, General Site Design and Facility Standards, the more specific building form standard shall apply, unless otherwise expressly stated. In case of conflict between a more specific design standard stated in this Article 10 and a design standard stated in this Division 10.2, General Site Design and Facility Standards, the more specific design standard shall apply, unless otherwise expressly stated.

### **SECTION 10.2.3 GENERAL SITE DESIGN AND FACILITY STANDARDS**

All development except Manufactured Home Replacement shall provide, as applicable:

- 10.2.3.1 Adequate design of grades, paving, gutters, drainage and treatment of turf to handle storm waters, prevent erosion and formation of dust;
- 10.2.3.2 Adequate, safe and convenient arrangement of pedestrian circulation facilities, roadways, driveways, off-street parking and loading space, facilities for waste disposal;
- 10.2.3.3 Arrangement of buildings and vehicular circulation open spaces so that pedestrians moving between buildings are not unnecessarily exposed to vehicular traffic;
- 10.2.3.4 Adequate amount and proper location of pedestrian walks, malls and landscaped spaces to separate horizontally or vertically pedestrian walks, malls and public transportation loading places from general vehicular circulation facilities;
- 10.2.3.5 Arrangement and orientation of buildings and location of Off-Street Parking Areas so as to minimize the impacts on adjacent properties;
- 10.2.3.6 Proper arrangement of signs and lighting devices with respect to traffic control devices and adjacent residential districts;
- 10.2.3.7 In development providing for family occupancy, adequate amount and safe location of play areas for children and other recreational areas according to the concentration of occupancy;
- 10.2.3.8 In development intended for nonresidential uses and located near or abutting Residential Zone Districts, provide fences, walls or year-round screen planting when necessary to shield adjacent residential districts from parking lot illumination, headlights, fumes, heat, blowing papers and dust and to reduce the visual encroachment of commercial architectural, signs and activity on residential privacy and residential neighborhood character;

- 10.2.3.9 Adequate consideration for the access needs of ~~disabled or handicapped residents~~ persons with disabilities through the provision of special parking spaces (per the Denver Building and Fire Code and the Americans with Disabilities Act), accessible routes between Off-Street Parking Areas and buildings, passenger loading zones, and access to other facilities in order to give ~~disabled residents~~ persons with disabilities an increased level of mobility;
- 10.2.3.10 Adequate identification of buildings, particularly in developments where two or more buildings use one street address or where two or more buildings are located on private streets or drives. For these cases, this Section's standards shall apply to all existing and future projects and shall require the following:
- A. The installation of temporary signs identifying each individual building at the beginning stage of its construction;
  - B. The installation of permanent identifying signs on each building that will allow quick identification by emergency service personnel and visitors; and
  - C. The installation of legible maps at the main vehicle entry points and/or signs showing all private streets or drives and their alignment throughout the project.

## DIVISION 10.4 PARKING AND LOADING

### SECTION 10.4.1 INTENT

The intent of Parking Standards, in conjunction with the building form standards according to Articles 3 through 9, is to:

- 10.4.1.1 ~~Balance the provision of adequate off-street parking to meet demand with city-wide objectives to~~ Encourage pedestrian-friendly environments and the use of multiple modes of transportation, including mass transit and bike parking requirements to reduce vehicle parking demand.
- 10.4.1.2 ~~Provide a variety of mechanisms to meet parking needs while promoting development and reinvestment in existing buildings, including Historic Structures.~~
- 10.4.1.3 ~~Recognize, through parking reductions, the parking efficiencies gained through mixed-use development, mixed income development, development proximate to rail and bus transit, and their impact on parking demand.~~
- 10.4.1.4 Promote bicycle use by providing safe and convenient bike parking through minimum requirements for type of bike parking facility and amount of bicycle spaces.
- 10.4.1.5 Encourage comprehensive, efficient, multi-site parking strategies.
- 10.4.1.6 Minimize the visual impacts of Off-Street Parking Areas, structures and garages on streets, open spaces, and adjoining development.
- 10.4.1.7 Design surface parking and parking structures to be visually compatible with the surrounding development, convenient for users, and mitigate the negative impact of vehicle noise, headlights, lighting and mechanical systems.
- 10.4.1.8 Integrate the function and appearance of parking structures into building groups so as to minimize negative impacts on public space and the pedestrian environment.
- 10.4.1.9 Design parking structure facades to reflect the predominant fenestration patterns of area buildings and to the extent possible wrap street facing elevations with active uses, especially at the Street Level.

### SECTION 10.4.2 VEHICLE AND BICYCLE PARKING - GENERAL RULES AND EXCEPTIONS

#### 10.4.2.1 Responsibility of Owner/Operator

The owner and operator of any land area, structure, or primary use ~~that generates a vehicle and bicycle parking requirement under this Code~~ shall have joint and several responsibility for providing all parking ~~required by according to~~ this Division 10.4 and maintaining that parking in accordance with the provisions of this Division.

#### 10.4.2.2 Accessible Vehicle Parking

~~Minimum Required: All pPrimary u~~Uses subject to this Division 10.4 shall provide accessible vehicle parking for disabled persons persons with disabilities that complies with the Denver Building and Fire Code and with the Americans with Disabilities Act (ADA) standards; ~~provided, however, that the amount of accessible parking provided for multi-unit dwelling uses shall be no less than one (1) space for each dwelling unit constructed for occupancy by a disabled person.~~

#### 10.4.2.3 Minimum Vehicle Parking in Approved Plans

The Manager shall not enforce any requirement for a minimum amount of vehicle parking stated in an approved regulating plan, site development plan or zoning permit.

#### 10.4.2.4 Minimum Vehicle Parking in Customized Zone Districts

The Manager shall not enforce any requirement for a minimum amount of vehicle parking stated in an approved Planned Unit Development (PUD) zone district or zone district with waivers or conditions.

### 10.4.2.5 Maintenance of Existing Parking Spaces

#### A. ~~No Reduction Allowed~~

~~Except as otherwise allowed in this Division 10.4 or Code, for land, structures, or primary uses, occupied or operated on or after June 25, 2010, the number of existing off-street vehicle and bicycle parking spaces shall not be reduced below the lesser of the number of spaces required under this Division 10.4 or the number of spaces legally established, including taking into account any exceptions allowed.~~

#### B. ~~Reduction Allowed for Improvement of Existing Off-Street Parking Area~~

~~The Zoning Administrator may reduce the number of parking spaces otherwise required by this Section 10.4.2.2 to allow the renovation or improvement of an existing Off-Street Parking Area, if the Zoning Administrator finds the following:~~

- ~~1. The reduction results in a substantial and material improvement to vehicle access, vehicle circulation, or pedestrian or bicyclist safety; and~~
- ~~2. The improved Off-Street Parking Area complies with all applicable standards stated in Sections 10.4.6, Vehicle Parking Design, and 10.5.4.4, Perimeter Surface Parking Lot Landscaping Standards.~~

~~Requests for this reduction shall be submitted and reviewed according to the procedure stated in Section 12.4.5, Administrative Adjustment.~~

### 10.4.2.6 Calculations

#### A. ~~General Rule~~

~~In determining the minimum number of ~~vehicle~~ ~~bicycle~~ parking spaces required or the maximum number of vehicle parking spaces allowed, fractional spaces are rounded to the nearest whole number, with one-half counted as an additional space.~~

#### B. ~~Gross Floor Area for Purposes of Calculating Parking Amounts~~

~~For the purposes of complying with ~~minimum and maximum~~ parking requirements, ~~g~~Gross ~~f~~Floor ~~a~~Area shall mean the sum of the gross horizontal areas of all of the floors of a building, including interior balconies and mezzanines, but excluding exterior balconies. All horizontal dimensions of each floor are to be measured by the exterior faces of walls of each such floor. The floor area of a building shall include the floor area of accessory buildings on the same ~~z~~Zone ~~H~~Lot, measured the same way. In computing ~~g~~Gross ~~f~~Floor ~~a~~Area, the following shall be excluded:~~

- ~~1. Any floor area devoted to mechanical equipment serving the building, provided that the floor area of such use occupies not less than 75 percent of the floor area of the story in which such mechanical equipment is located;~~
- ~~2. Any floor area used exclusively as parking space for vehicles or bicycles; and~~
- ~~3. Any floor area that serves as a pedestrian mall or public access way to shops and stores.~~

#### C. ~~“Unit” for Purposes of Calculating Parking Amounts~~

~~For the purposes of complying with ~~minimum and maximum~~ parking requirements, the term “unit” shall mean, as applicable, either:~~

- ~~1. A ~~d~~Dwelling ~~u~~Unit in a household living use, as “~~d~~Dwelling ~~u~~Unit” is defined in Article 11, Use Limitations and Definitions; or~~
- ~~2. A Room, which may or may not contain kitchen or bathing facilities, intended for occupancy by a resident or guest in a Residential Care or Congregate Living use.~~

### 10.4.2.7 Minimum/Maximum Parking Amount Required – General Rules and Exceptions

#### A. General Requirement

All primary uses shall provide a number of vehicle and bicycle parking spaces consistent with the context-specific minimum or maximum parking ratios stated in Articles 3 through 9, unless otherwise exempt, reduced, or allowed according to this Division 10.4.

#### B. Exception for Expansion and Change of Use

##### 1. When Required Parking is Based on GFA

###### a. Applicability

This subsection shall apply to expansions of existing Primary Uses, or a change in Primary Use, where the subject primary use(s)'s required amount of parking is based on the use's gross floor area (GFA) (e.g., a parking standard of 1 space/1,000-sf GFA).

###### b. No Additional Parking Required

After an expansion or change in use, if the gross floor area (GFA) of the expanded or new Primary Use(s) is reduced, stays the same, or increases by 25 percent or less compared to the previous Primary Use, no additional parking spaces are required.

###### c. Additional Parking of Increment Required

- i. If the gross floor area (GFA) of an existing Primary Use is expanded by more than 25 percent compared to the previously permitted gross floor area (GFA), additional off-street parking spaces shall be provided for the for the expanded additional Gross Floor Area ("increment") above the 25% increase in Gross Floor Area.
- ii. After a change of use, if the gross floor area (GFA) of the new Primary Use(s) exceeds the previous Primary Use(s)'s gross floor area (GFA) by more than 25 percent, additional off-street parking spaces shall be provided for the new additional Gross Floor Area ("increment") above the 25% increase in Gross Floor Area.

##### 2. When Required Parking is Based on Number of Units

###### a. Applicability

This subsection shall apply to expansions of existing Primary Uses, or a change of Primary Use, where either one or all the subject Primary Uses' required amounts of parking are based on the use's total number of units (e.g., a parking standard of 1 space/unit).

###### b. No Additional Parking Required

If the expanded or new Primary Use(s)'s minimum parking requirement exceeds the previous Primary Use(s)'s minimum parking requirement by 25 percent or less, no additional parking spaces are required.

###### c. Additional Parking of Increment Required

- i. After an expansion, if the expanded Primary Use(s)'s minimum parking requirement exceeds the previous Primary Use(s)'s minimum parking requirement by more than 25 percent, additional parking spaces shall be provided equal to the number that exceeds 125 percent of the previous Primary Use(s)'s minimum parking requirement.
- ii. After a change in use, if the new Primary Use (s)'s minimum parking requirement exceeds the previous Primary Use(s)'s minimum parking requirement by more than 25 percent, additional off-street parking spaces shall be provided equal to the number that exceeds 125 percent of the previous Primary Use(s)'s minimum parking requirement.

**For example:** After a change in use, the new Primary Use has a minimum parking requirement that results in 126 required vehicle parking spaces. The previous Primary Use had a parking minimum requirement that resulted in 100 required vehicle parking spaces. The new Primary Use shall only have to provide 1 additional vehicle parking space.

**d. Calculation of Minimum Parking Requirements**

For purposes of this Section 10.4.2.3.B, to calculate minimum parking requirements, the parking requirements contained in the applicable Use and Parking Table in Articles 3 through 9 of this Code shall be applied to the subject Primary Use(s).

**3. Retention of Existing Parking Required**

In the case of expansions and changes of use, existing and legally established parking spaces shall be retained according to Section 10.4.2.2, Maintenance of Existing Parking Spaces.

**4. Credit for On-Street Parking**

If additional vehicle parking is required per this subsection, "Exception for Expansion and Change of Use," a credit may be taken against the minimum number of additional vehicle parking spaces required in the amount of 1 space for each 25 feet of abutting street frontage, up to a maximum credit of 4 vehicle parking spaces.

**5. Improvement of Existing Off-Street Parking Area**

Except as otherwise allowed, when this subsection requires additional off-street parking spaces, all existing Off-Street Parking Areas shall comply with applicable standards in Section 10.4.6, Vehicle Parking Design. The Zoning Administrator may approve a reduction in the number of required parking spaces according to the findings, criteria, and procedure stated in Section 10.4.2.2.B, Reduction Allowed for Improvement of Existing Off-Street Parking Area.

**C. Exception for Change in Use in Existing Buildings Built Prior to 1967**

In all Mixed Use Commercial Zone Districts where minimum vehicle parking requirements apply, buildings shall be exempt from providing additional parking in the event of a change of use, provided all of the following are met:

1. The building was built before 1967;
2. The building meets the required build-to requirements of its assigned building form; and
3. The building meets the minimum height requirement of its assigned building form.

**D. Exception for Change in Use Subject to Maximum Vehicle Parking Standards**

In areas subject to maximum vehicle parking standards, if land area, structures, or primary uses providing off-street parking are changed from one primary use to any other primary use that has a lower maximum number of parking spaces allowed than the previous primary use, the following shall apply:

1. If the parking spaces from the previous primary use are equal to or less than 125 percent of the allowed parking maximum under the new primary use, then parking spaces may continue to be utilized by the uses located on that zone lot, and the parking spaces may be shared among uses, used jointly, or may be provided as shared vehicle parking according to Section 10.4.5.4, Shared Vehicle Parking; or
2. If the parking spaces from the previous primary use are greater than 125 percent of the allowed parking maximum under the new primary use, then parking spaces exceeding 125 percent of the maximum parking allowed under the new primary use shall be provided as shared vehicle parking according to Section 10.4.5.4, Shared Vehicle Parking.

- a. **Example:** The maximum parking allowed under a new primary use equals 60 parking spaces. The existing parking spaces from a previous primary use equals 100 parking spaces. The new primary use shall be required to provide 25 spaces as shared vehicle parking (60 maximum allowed spaces multiplied by 125 percent = 75 allowed spaces. 100 existing spaces minus 75 allowed spaces = 25 spaces required to be provided as shared vehicle parking).

## SECTION 10.4.3 BICYCLE PARKING - REQUIRED AMOUNT AND DESIGN

### 10.4.3.1 Applicability

Section 10.4.23, Vehicle and Bicycle Parking - General Rules and Exceptions Required Amount and Design, shall apply to all primary uses and changes of use, unless otherwise exempted, with the following exceptions:

- A. This Section 10.4.3 Bicycle Parking shall not apply in the D-C, D-TD, or D-CV zone districts. See Section 8.3.1.5, Off-Street Parking Requirements, for applicable bicycle parking standards for these districts.

### 10.4.3.2 Minimum/Maximum Bicycle Parking Amount Required - General Rules and Exceptions

#### A. General Requirement

All primary uses shall provide a minimum number of ~~vehicle and~~ bicycle parking spaces, consistent with the context-specific minimum or maximum parking ratios stated in Articles 3 through 9, unless otherwise exempt, reduced, or allowed according to this DivisionSection 10.4.3.

#### B. Maintenance of Existing Bicycle Parking Spaces - No Reduction Allowed

Except as otherwise allowed in this Division 10.4 or Code, for all legally established land, structures, or primary uses, ~~occupied or operated on or after June 25, 2010,~~ the number of existing ~~off-street vehicle and~~ bicycle parking spaces shall not be reduced below the lesser of the number of spaces required under this Division 10.4 or the number of spaces legally established, including taking into account any exceptions allowed.

#### C. Exception for Expansion and Change of Use

##### 1. When Required Bicycle Parking is Based on GFA

###### a. Applicability

This subsection shall apply to expansions of existing Primary Uses, or a change in Primary Use, where the subject ~~primary use~~ Primary Use(s)'s required amount of bicycle parking is based on the use's ~~gross floor area~~ Gross Floor Area (GFA) (e.g., a bicycle parking standard of 1 space/1,000 sf GFA).

###### b. No Additional Bicycle Parking Required

After an expansion or change in use, if the ~~gross floor area~~ Gross Floor Area (GFA) of the expanded or new Primary Use(s) is reduced, stays the same, or increases by 25 percent or less compared to the previous Primary Use, no additional bicycle parking spaces are required.

###### c. Additional Bicycle Parking of Increment Required

- i. If the ~~gross floor area~~ Gross Floor Area (GFA) of an existing Primary Use is expanded by more than 25 percent compared to the previously permitted ~~gross floor area~~ Gross Floor Area (GFA), additional ~~off-street~~ bicycle parking



spaces shall be provided for the for the expanded additional Gross Floor Area ("increment") above the 25% increase in Gross Floor Area.

- ii. After a change of use, if the ~~gross floor area~~ **Gross Floor Area** (GFA) of the new Primary Use(s) exceeds the previous Primary Use(s)'s ~~gross floor area~~ **Gross Floor Area** (GFA) by more than 25 percent, additional **off-street bicycle** parking spaces shall be provided for the new additional Gross Floor Area ("increment") above the 25% increase in Gross Floor Area.

## 2. When Required **Bicycle** Parking is Based on Number of Units

### a. **Applicability**

This subsection shall apply to expansions of existing Primary Uses, or a change of Primary Use, where either one or all the subject Primary Uses' required amounts of parking are based on the use's total number of units (e.g., a **bicycle** parking standard of 1 space/unit).

### b. **No Additional Parking Required**

If the expanded or new Primary Use(s)'s minimum **bicycle** parking requirement exceeds the previous Primary Use(s)'s minimum **bicycle** parking requirement by 25 percent or less, no additional **bicycle** parking spaces are required.

### c. **Additional Parking of Increment Required**

- i. After an expansion, if the expanded Primary Use(s)'s minimum **bicycle** parking requirement exceeds the previous Primary Use(s)'s minimum **bicycle** parking requirement by more than 25 percent, additional **bicycle** parking spaces shall be provided equal to the number that exceeds 125 percent of the previous Primary Use(s)'s minimum **bicycle** parking requirement.
- ii. After a change in use, if the new Primary Use (s)'s minimum **bicycle** parking requirement exceeds the previous Primary Use(s)'s minimum **bicycle** parking requirement by more than 25 percent, additional **off-street bicycle** parking spaces shall be provided equal to the number that exceeds 125 percent of the previous Primary Use(s)'s minimum **bicycle** parking requirement.

**For example:** After a change in use, the new Primary Use has a minimum **bicycle** parking requirement that results in 126 required ~~vehicle~~ parking spaces. The previous Primary Use had a **bicycle** parking minimum requirement that resulted in 100 required ~~vehicle~~ parking spaces. The new Primary Use shall only have to provide 1 additional ~~vehicle~~ **bicycle** parking space.

### d. **Calculation of Minimum Parking Requirements**

For purposes of this Section 10.4.2.3.B, to calculate minimum **bicycle** parking requirements, the **bicycle** parking requirements contained in ~~the applicable Use and Parking Table in Articles 3 through 9 of this Code~~ **Section 10.4.3 Bicycle Parking** shall be applied to the subject Primary Use(s).

## 3. Retention of Existing **Bicycle** Parking Required

In the case of expansions and changes of use, existing and legally established **bicycle** parking spaces shall be retained according to Section 10.4.2.~~25~~, Maintenance of Existing Parking Spaces.

## D. **Reductions in Required Amount of Bicycle Parking**

The Zoning Administrator may adjust the bicycle parking requirement in the following ways:

1. A reduction in the total number of bicycle parking spaces required for a primary use, up to a maximum 20% reduction. A reduction in the total number of spaces does not change the proportional (%) distribution of the required spaces to an enclosed or fixed bicycle rack parking facility; or

2. A modification in the number of bicycle parking spaces that must be provided in either an enclosed or fixed bicycle rack parking facility, up to a maximum 20% adjustment, provided any reduction in the number of spaces provided in one type of parking facility shall be provided in the other type of parking facility.
    - a. **For example:** When a total of 20 bicycle parking spaces is required and 10 shall be provided in an enclosed storage facility and 10 shall be provided in a fixed bicycle rack parking facility, the Zoning Administrator may modify the amount that must be enclosed, resulting in a reduction from the original 10 enclosed spaces to 8 enclosed spaces. That would require a total of 12 spaces in a fixed bicycle rack parking facility.
  3. Wherever fixed bicycle parking requirements result in 20 or more fixed bicycle spaces per street frontage, only 20 fixed bicycle parking spaces shall be required along each street frontage. Any additional required fixed bicycle parking may instead be provided as enclosed bicycle parking. This shall not reduce the total number of bicycle parking spaces required.
- E. Preservation of Existing Trees**  
If, in order to comply with bicycle parking requirements, it would be necessary to remove mature, existing trees, the Zoning Administrator may allow reasonable reductions in the number of required bicycle parking spaces.

#### 10.4.3.3 Calculation

- A. When a primary use's required amount of bicycle parking is 2 spaces or less, not including Primary Uses that don't require bicycle parking, the use shall provide a minimum of 2 bicycle parking spaces in a fixed rack bicycle parking facility.
- B. ~~In determining the number of bicycle parking spaces required, fractional spaces are rounded to the nearest whole number, with one-half counted as an additional space.~~
- C. In determining the number of bicycle parking spaces that must be sited in an enclosed bicycle facility or a fixed rack bicycle facility, fractional spaces are rounded to the nearest whole number, with one-half counted as an additional space.
- D. All required spaces "per square feet" are measured as ~~gross floor area~~ Gross Floor Area, unless otherwise specified.
- E. For residential uses, the bicycle parking requirement shall be calculated separately for separate residential buildings.
- F. Where any building or zone lot contains two or more uses having different bicycle parking requirements, the bicycle parking requirements for each use shall apply proportionally to the extent of that use's ~~gross floor area~~ Gross Floor Area in the building or on the zone lot.

#### 10.4.3.4 Bicycle Parking Exceptions

- A. Reductions in Required Amount of Bicycle Parking**  
The Zoning Administrator may adjust the bicycle parking requirement in the following ways:
1. ~~A reduction in the total number of bicycle parking spaces required for a primary use, up to a maximum 20% reduction. A reduction in the total number of spaces does not change the proportional (%) distribution of the required spaces to an enclosed or fixed bicycle rack parking facility; or~~
  2. ~~A modification in the number of bicycle parking spaces that must be provided in either an enclosed or fixed bicycle rack parking facility, up to a maximum 20% adjustment,~~

~~provided any reduction in the number of spaces provided in one type of parking facility shall be provided in the other type of parking facility.~~

a. ~~**For example:** When a total of 20 bicycle parking spaces is required and 10 shall be provided in an enclosed storage facility and 10 shall be provided in a fixed bicycle rack parking facility, the Zoning Administrator may modify the amount that must be enclosed, resulting in a reduction from the original 10 enclosed spaces to 8 enclosed spaces. That would require a total of 12 spaces in a fixed bicycle rack parking facility.~~

- ~~3. Wherever fixed bicycle parking requirements result in 20 or more fixed bicycle spaces per street frontage, only 20 fixed bicycle parking spaces shall be required along each street frontage. Any additional required fixed bicycle parking may instead be provided as enclosed bicycle parking. This shall not reduce the total number of bicycle parking spaces required.~~

**B. Preservation of Existing Trees**

~~If, in order to comply with bicycle parking requirements, it would be necessary to remove mature, existing trees, the Zoning Administrator may allow reasonable reductions in the number of required bicycle parking spaces.~~

### 10.4.3.5 Required Types of Bicycle Parking Facilities

In order to meet the minimum required bike parking spaces, there are two types of bicycle parking facilities that may be required. The description and minimum standards for each type of bicycle parking facility are as follows. Such facilities may be placed on private property or within the public right-of-way. Facilities in the public right-of-way require a permit by the Department of Transportation and Infrastructure ("DOTI").

**A. Enclosed Bicycle Parking Facility**

An enclosed bicycle parking facility shall be provided through various methods provided it meets the following minimum standards:

1. Shall provide enclosed bicycle storage in lockers, a room within a building, or within a parking structure.
2. All types of enclosed bicycle storage shall be easily accessible to all building occupants and to public entrances and walkways, secure, well lighted, and weather resistant.
3. Each storage space shall provide a minimum of 15 square feet in area. The Zoning Administrator may reduce the minimum area up to 6 square feet if a more efficient layout is provided.

**B. Fixed Bicycle Rack Parking Facility**

A fixed bicycle rack parking facility shall be provided through various methods provided it meets the following minimum design standards:

1. Fixed bicycle racks shall be securely anchored.
2. Fixed bicycle racks must be publicly accessible to building entrances and walkways.
3. Spacing of the racks shall provide clear and maneuverable access.
4. Where two bikes can be locked on both sides without conflict, each side can be counted as one required space.

### 10.4.3.6 Minimum Bicycle Parking Requirements

#### A. Applicability and Exceptions

##### 1. General Rule

Where specified in the table below, bicycle parking is required for specific primary uses, with standards that vary by neighborhood context, special context, or specific zone district, excepting the D-C, D-TD, D-CV, DIA, OS-A, OS-C, and MHC Zone Districts.

##### 2. Exceptions for the OS-A and DIA Zone Districts

See Article 9 for development standards governing parking in the OS-A and DIA zone districts.

#### B. District-Specific Requirements

In all D-C, D-TD, and D-CV Zone Districts, all new parking structures shall contain at least 1 designated bicycle parking space for each 20 automobile parking spaces, provided, however, that in no event shall any new parking structure be required to ~~contain~~ provide more than 50 bicycle parking spaces.

#### C. General Requirements

Bicycle parking requirements are formatted as number of spaces required per unit of measurement (percentage of required spaces in an enclosed facility/percentage of required spaces in a fixed facility).

USE CATEGORY	SPECIFIC USE TYPE	ALL S-, I-A, I-B, OS-B, O-1 ZONE DISTRICTS	ALL E- ZONE DISTRICTS	ALL U-, M- ZONE DISTRICTS	ALL G-, I-MX ZONE DISTRICTS	ALL C-, CMP ZONE DISTRICTS	ALL D-CPV-T, D-CPV-R, D-CPV-C ZONE DISTRICTS	ALL D-LD, D-GT, D-AS, D-AS-12+, D-AS-20+ ZONE DISTRICTS
<b>RESIDENTIAL PRIMARY USE CLASSIFICATION</b>								
Household Living	Dwelling, Single Unit	No requirement						
	Dwelling, Two Unit	No requirement						
	Dwelling, Multi-Unit	1/5 units (80/20)	1/5 units (80/20)	1/4 units (80/20)	I-MX: 1/5 units (80/20) All Others: 1/4 units (80/20)	1/2 units (80/20)	1.1/unit (80/20)	D-LD Districts: 1.1/unit (80/20) All Others: 1/2 units (80/20)
	Dwelling, Live / Work	1/5 units (80/20)	1/5 units (80/20)	1/4 units (80/20)	I-MX: 1/5 units (80/20) All Others: 1/4 units (80/20)	1/2 units (80/20)	1.1/unit (80/20)	D-LD Districts: No requirement All Others: 1/2 units (80/20)
	Manufactured Home Community	No requirement						
Residential Care	Residential Care, Type 1	No Requirement	No Requirement	No Requirement	No Requirement	No Requirement	1/8,000 sf GFA (80/20)	1/8,000 sf GFA (80/20)
	Residential Care, Type 2	No Requirement	No Requirement	No Requirement	No Requirement	No Requirement	1/8,000 sf GFA (80/20)	1/8,000 sf GFA (80/20)
	Residential Care, Type 3	No Requirement	No Requirement	No Requirement	No Requirement	No Requirement	1/8,000 sf GFA (80/20)	1/8,000 sf GFA (80/20)
	Residential Care, Type 4	No Requirement	No Requirement	No Requirement	No Requirement	No Requirement	1/8,000 sf GFA (80/20)	1/8,000 sf GFA (80/20)
Congregate Living	All Types	1/20,000 sf GFA (80/20)	1/20,000 sf GFA (80/20)	1/20,000 sf GFA (80/20)	1/20,000 sf GFA (80/20)	1/20,000 sf GFA (80/20)	1/8,000 sf GFA (80/20)	1/8,000 sf GFA (80/20)
<b>CIVIC, PUBLIC &amp; INSTITUTIONAL PRIMARY USE CLASSIFICATION</b>								
Basic Utilities	All Types	No requirement						

USE CATEGORY	SPECIFIC USE TYPE	ALL S-, I-A, I-B, OS-B, O-1 ZONE DISTRICTS	ALL E- ZONE DISTRICTS	ALL U-, M- ZONE DISTRICTS	ALL G-, I-MX ZONE DISTRICTS	ALL C-, CMP ZONE DISTRICTS	ALL D-CPV-T, D-CPV-R, D-CPV-C ZONE DISTRICTS	ALL D-LD, D-GT, D-AS, D-AS-12+, D-AS-20+ ZONE DISTRICTS	
Community/ Public Services	Community Center	1/10,000 sf GFA (0/100)	1/10,000 sf GFA (0/100)	1/10,000 sf GFA (0/100)	1/10,000 sf GFA (0/100)	1/10,000 sf GFA (0/100)	No requirement	No requirement	
	Day Care Center	1/10,000 sf GFA (0/100)	1/10,000 sf GFA (0/100)	1/10,000 sf GFA (0/100)	1/10,000 sf GFA (0/100)	1/10,000 sf GFA (0/100)	1/5,000 sf GFA (0/100)	D-LD: No requirement All Others: 1/10,000 sf GFA (0/100)	
	Postal Facility, Neighborhood	1/20,000 sf GFA (20/80)	1/20,000 sf GFA (60/40)	M-: 1/10,000 sf GFA (60/40) All Others: 1/10,000 sf GFA (20/80)	I-MX: 1/20,000 sf GFA (20/80) All Others: 1/10,000 sf GFA (20/80)	1/7,500 sf GFA (20/80)	1/4,000 sf GFA (20/80)	D-LD: No requirement All Others: 1/7,500 sf GFA (20/80)	
	Postal Processing Center	1/20,000 sf GFA (20/80)	1/20,000 sf GFA (60/40)	M-: 1/10,000 sf GFA (0/100) All Others: 1/10,000 sf GFA (20/80)	I-MX: 1/20,000 sf GFA (20/80) All Others: 1/10,000 sf GFA (20/80)	1/7,500 sf GFA (20/80)	1/4,000 sf GFA (20/80)	D-LD: No requirement All Others: 1/7,500 sf GFA (20/80)	
	Public Safety Facility	1/10,000 sf GFA (0/100)	1/10,000 sf GFA (0/100)	1/10,000 sf GFA (0/100)	1/10,000 sf GFA (0/100)	1/10,000 sf GFA (0/100)	1/10,000 sf GFA (0/100)	D-LD: No requirement All Others: 1/10,000 sf GFA (0/100)	
	Hospital Correctional Institution Cemetery	No requirement							
Cultural/ Special Purpose/ Public Parks & Open Space	Library	1/10,000 sf GFA (0/100)	1/10,000 sf GFA (0/100)	1/10,000 sf GFA (0/100)	1/10,000 sf GFA (0/100)	1/10,000 sf GFA (0/100)	1/5,000 sf GFA (0/100)	D-LD: No requirement All Others: 1/10,000 sf GFA (0/100)	
	Museum	1/10,000 sf GFA (0/100)	1/10,000 sf GFA (0/100)	1/10,000 sf GFA (0/100)	1/10,000 sf GFA (0/100)	1/10,000 sf GFA (0/100)	1/5,000 sf GFA (0/100)	D-LD: No requirement All Others: 1/10,000 sf GFA (0/100)	
	City Park Open Space - Conservation	No requirement							
		No requirement							

USE CATEGORY	SPECIFIC USE TYPE	ALL S-, I-A, I-B, OS-B, O-1 ZONE DISTRICTS	ALL E- ZONE DISTRICTS	ALL U-, M- ZONE DISTRICTS	ALL G-, I-MX ZONE DISTRICTS	ALL C-, CMP ZONE DISTRICTS	ALL D-CPV-T, D-CPV-R, D-CPV-C ZONE DISTRICTS	ALL D-LD, D-GT, D-AS, D-AS-12+, D-AS-20+ ZONE DISTRICTS	
Education	Elementary or Secondary School	High School: 1/20,000 sf GFA (0/100) All Others: 1/10,000 sf GFA (0/100)	High School: 1/20,000 sf GFA (0/100) All Others: 1/10,000 sf GFA (0/100)	1/10,000 sf GFA (0/100)	I-MX: No Requirement All Others: 1/10,000 sf GFA (0/100)	CMP: High School: 1/5,000 sf GFA (0/100) All Others: 1/10,000 sf GFA (0/100)	1/5,000 sf GFA (0/100)	D-LD: No requirement All Others: Elementary: 1/10,000 sf GFA (0/100) Secondary: 1/5,000 sf GFA (0/100)	
	University or College	1/10,000 sf GFA (0/100)	1/10,000 sf GFA (0/100)	1/10,000 sf GFA (0/100)	1/10,000 sf GFA (0/100)	1/10,000 sf GFA (0/100)	1/5,000 sf GFA (0/100)	D-LD: No requirement All Others: 1/10,000 sf GFA (0/100)	
	Vocational or Professional School	1/10,000 sf GFA (0/100)	1/10,000 sf GFA (0/100)	1/10,000 sf GFA (0/100)	1/10,000 sf GFA (0/100)	1/10,000 sf GFA (0/100)	1/10,000 sf GFA (0/100)	D-LD: No requirement All Others: 1/10,000 sf GFA (0/100)	
Public and Religious Assembly	All Types	1/10,000 sf GFA (0/100)	1/10,000 sf GFA (0/100)	1/10,000 sf GFA (0/100)	1/10,000 sf GFA (0/100)	CMP: No requirement All Others: 1/10,000 sf GFA (0/100)	No requirement	No requirement	
<b>COMMERCIAL SALES, SERVICES, &amp; REPAIR PRIMARY USE CLASSIFICATION</b>									
Adult Business	All Types (where permitted by Adult Use Overlay District)	1/20,000 sf GFA (20/80)	1/20,000 sf GFA (20/80)	1/10,000 sf GFA (20/80)	I-MX: 1/20,000 sf GFA (20/80) All Others: 1/10,000 sf GFA (20/80)	1/7,500 sf GFA (20/80)	No requirement	D-LD: No requirement All Others: 1/7,500 sf GFA (20/80)	
Arts, Recreation, & Entertainment	Arts, Recreation, and Entertainment Services, Indoor	OS-B: 1/10,000 sf GFA (60/40) All Others: 1/20,000 sf GFA (20/80)	1/20,000 sf GFA (20/80)	M-: 1/10,000 sf GFA (60/40) All Others: 1/10,000 sf GFA (20/80)	I-MX: 1/20,000 sf GFA (20/80) All Others: 1/10,000 sf GFA (20/80)	1/7,500 sf GFA (20/80)	1/4,000 sf GFA (20/80)	D-LD: No requirement All Others: 1/7,500 sf GFA (20/80)	
	Arts, Recreation, and Entertainment Services, Outdoor	OS-B: 1/10,000 sf GFA (60/40) All Others: 1/20,000 sf GFA (20/80)	1/20,000 sf GFA (20/80)	M-: 1/10,000 sf GFA (60/40) All Others: 1/10,000 sf GFA (20/80)	I-MX: 1/20,000 sf GFA (20/80) All Others: 1/10,000 sf GFA (20/80)	1/7,500 sf GFA (20/80)	1/4,000 sf GFA (20/80)	D-LD: No requirement All Others: 1/7,500 sf GFA (20/80)	
	Event Space with Alternate Parking and Loading	No requirement							
	Sports and/or Entertainment Arena or Stadium	OS-B: 1/10,000 sf GFA (0/100) All Others: No requirement	No requirement						
Parking of Vehicles	All Types	No requirement							

USE CATEGORY	SPECIFIC USE TYPE	ALL S-, I-A, I-B, OS-B, O-1 ZONE DISTRICTS	ALL E- ZONE DISTRICTS	ALL U-, M- ZONE DISTRICTS	ALL G-, I-MX ZONE DISTRICTS	ALL C-, CMP ZONE DISTRICTS	ALL D-CPV-T, D-CPV-R, D-CPV-C ZONE DISTRICTS	ALL D-LD, D-GT, D-AS, D-AS-12+, D-AS-20+ ZONE DISTRICTS
<u>Eating &amp; Drinking Establishments</u>	<u>All Types</u>	<u>1/5,000 sf GFA (0/100)</u>	<u>1/5,000 sf GFA (0/100)</u>	<u>M-: 1/3,000 sf GFA (0/100)</u> <u>All Others: 1/5,000 sf GFA (0/100)</u>	<u>I-MX: 1/5,000 sf GFA (0/100)</u> <u>All Others: 1/3,000 sf GFA (0/100)</u>	<u>1/1,500 sf GFA (0/100)</u>	<u>1/1,000 sf GFA (0/100)</u>	<u>D-LD: No requirement</u> <u>All Others: 1/1,000 sf GFA (0/100)</u>
<u>Lodging Accommodations</u>	<u>Bed and Breakfast Lodging</u>	<u>1/20,000 sf GFA (60/40)</u>	<u>1/20,000 sf GFA (60/40)</u>	<u>1/10,000 sf GFA (60/40)</u>	<u>I-MX: 1/20,000 sf GFA (60/40)</u> <u>All Others: 1/10,000 sf GFA (60/40)</u>	<u>1/7,500 sf GFA (60/40)</u>	<u>1/7,500 sf GFA (20/80)</u>	<u>D-LD: No requirement</u> <u>All Others: 1/7,500 sf GFA (20/80)</u>
	<u>Lodging Accommodations, All Others</u>	<u>1/20,000 sf GFA (60/40)</u>	<u>1/20,000 sf GFA (60/40)</u>	<u>1/10,000 sf GFA (60/40)</u>	<u>I-MX: 1/20,000 sf GFA (60/40)</u> <u>All Others: 1/10,000 sf GFA (60/40)</u>	<u>1/7,500 sf GFA (60/40)</u>	<u>1/7,500 sf GFA (20/80)</u>	<u>D-LD: No requirement</u> <u>All Others: 1/7,500 sf GFA (20/80)</u>
<u>Office</u>	<u>Dental / Medical Office or Clinic</u>	<u>1/20,000 sf GFA (60/40)</u>	<u>1/20,000 sf GFA (20/80)</u>	<u>1/10,000 sf GFA (60/40)</u>	<u>I-MX: 1/20,000 sf GFA (60/40)</u> <u>All Others: 1/10,000 sf GFA (60/40)</u>	<u>1/7,500 sf GFA (60/40)</u>	<u>1/4,000 sf GFA (20/80)</u>	<u>D-LD: No requirement</u> <u>All Others: 1/7,500 sf GFA (20/80)</u>
	<u>Office, All Others</u>	<u>1/20,000 sf GFA (60/40)</u>	<u>1/20,000 sf GFA (20/80)</u>	<u>1/10,000 sf GFA (60/40)</u>	<u>I-MX: 1/20,000 sf GFA (60/40)</u> <u>All Others: 1/10,000 sf GFA (60/40)</u>	<u>1/7,500 sf GFA (60/40)</u>	<u>1/4,000 sf GFA (20/80)</u>	<u>D-LD: No requirement</u> <u>All Others: 1/7,500 sf GFA (20/80)</u>

USE CATEGORY	SPECIFIC USE TYPE	ALL S-, I-A, I-B, OS-B, O-1 ZONE DISTRICTS	ALL E- ZONE DISTRICTS	ALL U-, M- ZONE DISTRICTS	ALL G-, I-MX ZONE DISTRICTS	ALL C-, CMP ZONE DISTRICTS	ALL D-CPV-T, D-CPV-R, D-CPV-C ZONE DISTRICTS	ALL D-LD, D-GT, D-AS, D-AS-12+, D-AS-20+ ZONE DISTRICTS
Retail Sales, Service & Repair (Not Including Vehicle or Equipment Sales, Service & Repair)	Animal Sales and Services, Household Pets Only	<u>1/20,000 sf GFA (20/80)</u>	<u>1/20,000 sf GFA (20/80)</u>	<u>M-: 1/10,000 sf GFA (60/40)</u> <u>All Others: 1/10,000 sf GFA (20/80)</u>	<u>I-MX: 1/20,000 sf GFA (20/80)</u> <u>All Others: 1/10,000 sf GFA (20/80)</u>	<u>1/7,500 sf GFA (20/80)</u>	<u>1/4,000 sf GFA (20/80)</u>	<u>D-LD: No requirement</u> <u>All Others: 1/7,500 sf GFA (20/80)</u>
	Animal Sales and Services, All Others	<u>No requirement</u>	<u>No requirement</u>	<u>M-: 1/20,000 sf GFA (60/40)</u> <u>All Others: No requirement</u>	<u>I-MX: 1/20,000 sf GFA (20/80)</u> <u>All Others: No requirement</u>	<u>CMP: 1/7,500 sf GFA (20/80)</u> <u>All Others: No requirement</u>	<u>No requirement</u>	<u>No requirement</u>
	Food Sales or Market	<u>1/20,000 sf GFA (20/80)</u>	<u>1/20,000 sf GFA (20/80)</u>	<u>M-: 1/10,000 sf GFA (60/40)</u> <u>All Others: 1/10,000 sf GFA (20/80)</u>	<u>I-MX: 1/20,000 sf GFA (20/80)</u> <u>All Others: 1/10,000 sf GFA (20/80)</u>	<u>1/7,500 sf GFA (20/80)</u>	<u>1/4,000 sf GFA (20/80)</u>	<u>D-LD: No requirement</u> <u>All Others: 1/7,500 sf GFA (20/80)</u>
	Pawn Shop	<u>No requirement</u>	<u>No requirement</u>	<u>1/10,000 sf GFA (20/80)</u>	<u>No requirement</u>	<u>No requirement</u>	<u>1/4,000 sf GFA (20/80)</u>	<u>D-LD: No requirement</u> <u>All Others: 1/7,500 sf GFA (20/80)</u>
	Retail Sales, Service & Repair -- Outdoor	<u>1/20,000 sf GFA (20/80)</u>	<u>1/20,000 sf GFA (20/80)</u>	<u>M-: 1/10,000 sf GFA (60/40)</u> <u>All Others: 1/10,000 sf GFA (20/80)</u>	<u>No requirement</u>	<u>No requirement</u>	<u>No requirement</u>	<u>No requirement</u>
	Retail Sales, Service & Repair - Firearms Sales	<u>1/20,000 sf GFA (20/80)</u>	<u>1/20,000 sf GFA (20/80)</u>	<u>M-: 1/10,000 sf GFA (60/40)</u> <u>All Others: No requirement</u>	<u>I-MX: 1/20,000 sf GFA (20/80)</u> <u>All Others: 1/10,000 sf GFA (20/80)</u>	<u>1/7,500 sf GFA (20/80)</u>	<u>No requirement</u>	<u>No requirement</u>
	Retail Sales, Service & Repair, All Others	<u>1/20,000 sf GFA (20/80)</u>	<u>1/20,000 sf GFA (20/80)</u>	<u>M-: 1/10,000 sf GFA (60/40)</u> <u>All Others: 1/10,000 sf GFA (20/80)</u>	<u>I-MX: 1/20,000 sf GFA (20/80)</u> <u>All Others: 1/10,000 sf GFA (20/80)</u>	<u>1/7,500 sf GFA (20/80)</u>	<u>1/4,000 sf GFA (20/80)</u>	<u>D-LD: No requirement</u> <u>All Others: 1/7,500 sf GFA (20/80)</u>
Vehicle / Equipment Sales, Rentals, Service & Repair	All Types	<u>No requirement</u>						
<b>INDUSTRIAL, MANUFACTURING &amp; WHOLESALE PRIMARY USE CLASSIFICATION</b>								
Communica-tions and Information	All Types	<u>No requirement</u>						
Industrial Services	All Types	<u>No requirement</u>						
Manufac-turing and Production	All Types	<u>No requirement</u>						



USE CATEGORY	SPECIFIC USE TYPE	ALL S-, I-A, I-B, OS-B, O-1 ZONE DISTRICTS	ALL E- ZONE DISTRICTS	ALL U-, M- ZONE DISTRICTS	ALL G-, I-MX ZONE DISTRICTS	ALL C-, CMP ZONE DISTRICTS	ALL D-CPV-T, D-CPV-R, D-CPV-C ZONE DISTRICTS	ALL D-LD, D-GT, D-AS, D-AS-12+, D-AS-20+ ZONE DISTRICTS
<a href="#">Mining &amp; Extraction and Energy Producing Systems</a>	<a href="#">All Types</a>							<a href="#">No requirement</a>
<a href="#">Transportation Facilities</a>	<a href="#">All Types</a>							<a href="#">No requirement</a>
<a href="#">Waste Related Services</a>	<a href="#">All Types</a>							<a href="#">No requirement</a>
<a href="#">Wholesale, Storage, Warehouse &amp; Distribution</a>	<a href="#">All Types</a>							<a href="#">No requirement</a>
<b>AGRICULTURE PRIMARY USE CLASSIFICATION</b>								
<a href="#">Agriculture</a>	<a href="#">All Types</a>							<a href="#">No requirement</a>

## SECTION 10.4.4 ~~MINIMUM AND~~ MAXIMUM VEHICLE PARKING

### 10.4.4.1 Applicability ~~and Exceptions~~

**A. General Rule**

Section 10.4.2.1, Responsibility of Owner/Operator, shall apply.

**B. ~~Exceptions for the OS-A and DIA Zone Districts~~**

~~See Article 9 for development standards governing parking in the OS-A and DIA zone districts.~~

### 10.4.4.2 Calculations

**A. General Rule**

1. ~~In determining the minimum number of vehicle parking spaces required or the maximum number of vehicle parking spaces allowed, fractional spaces are rounded to the nearest whole number, with one-half counted as an additional space.~~
2. ~~Except when shared parking is allowed (see Section 10.4.5.4 Shared Vehicle Parking), when a zone lot is used for a combination of uses, the minimum vehicle parking requirement shall be the sum of the requirements for each use and may be used jointly. In areas where maximum vehicle parking standards apply, except when shared parking for off-site uses is being provided according to Section 10.4.5.4, Shared Vehicle Parking, where a zone lot contains multiple primary uses subject to maximum parking standards, the total amount of parking provided on the zone lot shall not exceed the aggregate maximum parking allowed for those uses, and may be used jointly.~~
3. Vehicle queuing spaces serving permitted fuel pumps where the spaces meet the dimensional standards for a 0° parking space as required in Section 10.4.6, Vehicle Parking Design, shall count toward the number of maximum vehicle parking spaces.
4. **Van-accessible, Electric Vehicle Charging Parking Spaces**
  - a. ~~For purposes of calculating minimum parking requirements, any parking space that complies with the following shall be counted as 2 required parking spaces:-~~

- i. ~~The parking space meets the minimum dimensional standards for a van-accessible parking space;~~
  - ii. ~~The parking space is served by Electric Vehicle Supply Equipment; and~~
  - iii. ~~The parking space shall be made available for general use, rather than reserved exclusively for the holders of an identifying plate or placard issued under C.R.S. section 42-4-1208.~~
- b. ~~The parking spaces provided to meet the requirements in 10.4.4.2.A.4.a.i-iii shall count as 1 required parking space for purposes of calculating maximum vehicle parking where applicable.~~

**B. Gross Floor Area for Purposes of Calculating Parking Amounts**

~~For the purposes of complying with minimum and maximum parking requirements, gross floor area shall mean the sum of the gross horizontal areas of all of the floors of a building, including interior balconies and mezzanines, but excluding exterior balconies. All horizontal dimensions of each floor are to be measured by the exterior faces of walls of each such floor. The floor area of a building shall include the floor area of accessory buildings on the same zone lot, measured the same way. In computing gross floor area, the following shall be excluded:~~

1. ~~Any floor area devoted to mechanical equipment serving the building, provided that the floor area of such use occupies not less than 75 percent of the floor area of the story in which such mechanical equipment is located;~~
2. ~~Any floor area used exclusively as parking space for vehicles or bicycles; and~~
3. ~~Any floor area that serves as a pedestrian mall or public access way to shops and stores.~~

**C. "Unit" for Purposes of Calculating Parking Amounts**

~~For the purposes of complying with minimum and maximum parking requirements, the term "unit" shall mean, as applicable, either:~~

1. ~~A dwelling unit in a household living use, as "dwelling unit" is defined in Article 11, Use Limitations and Definitions; or~~
2. ~~A Room, which may or may not contain kitchen or bathing facilities, intended for occupancy by a resident or guest in a Residential Care or Congregate Living use.~~

**D. Guest Parking in Districts with Maximum Vehicle Parking Standards**

**1. Intent**

~~To allow flexibility for a limited amount of guest parking in zone districts with maximum vehicle parking standards.~~

**2. Applicability**

~~This Section 10.4.4.2.D applies to all residential primary uses in zone districts where maximum vehicle parking standards apply.~~

**3. Standards**

- a. ~~On a zone lot containing at least 3 and no more than 19 dwelling units, one additional vehicle parking space may be provided for guest parking.~~
- b. ~~On a zone lot containing 20 or more dwelling units, one additional vehicle parking space may be provided for guest parking for every 20 dwelling units. For example, a 42-unit development may provide two additional parking spaces for guest parking.~~
- c. ~~Except when shared parking is being provided on a separate zone lot according to Section 10.4.5.4, Shared Vehicle Parking, all guest parking must be located on the same zone lot as the residential primary use for which it is being provided.~~

**10.4.4.3 Accessible Vehicle Parking**

Minimum Required: All primary uses subject to this Division 10.4 shall provide accessible parking for disabled persons that complies with the Denver Building and Fire Code and with the Americans with Disabilities Act (ADA) standards, provided, however, that the amount of accessible parking provided for multi-unit dwelling uses shall be no less than one (1) space for each dwelling unit constructed for occupancy by a disabled person.

**10.4.4.4 Exception for Change in Use Subject to Maximum Vehicle Parking Standards**

In areas subject to maximum vehicle parking standards, if land area, structures, or primary uses providing off-street parking are changed from one primary use to any other primary use that has a lower maximum number of parking spaces allowed than the previous primary use, then parking spaces may continue to be utilized by the uses located on that zone lot, and the parking spaces may be shared among uses.

**10.4.4.5 Maximum Vehicle Parking Requirements for Downtown Central Platte Valley – Auraria Districts**

**A. Intent**

1. To promote active, transit-supportive development that leverages the regional transit infrastructure investment in the Downtown Central Platte Valley - Auraria districts.
2. To reduce the number of vehicle trips within and around the Downtown Central Platte Valley - Auraria districts and encourage alternative travel modes such as walking, biking, and transit.
3. To promote the efficient development of land in the Downtown Central Platte Valley - Auraria districts by limiting the amount of land dedicated to vehicle parking.

**B. Applicability**

This Section ~~8.11.5~~ 10.4.4.5 applies to all Structures in the D-CPV-T, D-CPV-R and D-CPV-C zone districts.

**C. Vehicle Parking Standards**

The following table establishes the maximum vehicle parking allowed in the D-CPV-T, D-CPV-R and D-CPV-C zone districts based on the allowed primary uses by zone district.

USE CATEGORY	SPECIFIC USE TYPE	MAXIMUM VEHICLE PARKING: # SPACES PER UNIT OF MEASUREMENT
<b>RESIDENTIAL PRIMARY USE CLASSIFICATION</b>		
Household Living	Dwelling, Single Unit	No Maximum
	Dwelling, Two Unit	No Maximum
	All other specific use types within the Household Living Use Category	0.7/Unit for each unit with 0-1 bedrooms 1.0/Unit for each unit with 2 bedrooms 1.3/Unit for each unit with 3+ bedrooms
Group Living Residential Care	<del>Residence for Older Adults</del> <del>All Types containing Dwelling Units</del>	0.7/Unit for each unit with 0-1 bedrooms 1.0/Unit for each unit with 2 bedrooms 1.3/Unit for each unit with 3+ bedrooms
	<del>Rooming and Boarding House</del> <del>All Other Types</del>	1.25/1,000 sf GFA
	<del>Shelter for the Homeless</del>	<del>1.25/1,000 sf GFA</del>
	<del>All other specific use types within the Group Living Use Category</del>	<del>0.7/Unit</del>
Congregate Living	<del>All Types containing Dwelling Units</del>	0.7/Unit
	<del>All Other Types</del>	1.25/1,000 sf GFA
<b>CIVIC, PUBLIC &amp; INSTITUTIONAL PRIMARY USE CLASSIFICATION</b>		

USE CATEGORY	SPECIFIC USE TYPE	MAXIMUM VEHICLE PARKING: # SPACES PER UNIT OF MEASUREMENT
	All specific use types within the Civic, Public & Institutional Primary Use Classification	1.25/1,000 sf GFA
<b>COMMERCIAL SALES, SERVICE &amp; REPAIR PRIMARY USE CLASSIFICATION</b>		
Arts, Recreation & Entertainment	Arts, Recreation and Entertainment Services, Indoor	1.25/1,000 sf GFA
	Arts, Recreation and Entertainment Services, Outdoor	6.0/1,000 sf GFA
	Sports and/or Entertainment Arena or Stadium	6.0/1,000 sf GFA
Parking of Vehicles	Parking, Garage	No Maximum*
Eating & Drinking Establishments	All Types	2.0/1,000 sf GFA
Lodging Accommodations	Bed and Breakfast Lodging	0.5/guest room or unit
	Lodging Accommodations, All Others	0.5/guest room or unit
	All other specific use types within the Commercial Sales, Service, & Repair Primary Use Classification	1.25/1,000 sf GFA
<b>INDUSTRIAL, MANUFACTURING &amp; WHOLESALE PRIMARY USE CLASSIFICATION</b>		
Transportation Facilities	Terminal, Station or Service Facility for Passenger Transit System	No Maximum*
	All other specific use types within the Industrial, Manufacturing & Wholesale Primary Use Classification	1.25/1,000 sf GFA
<b>AGRICULTURE PRIMARY USE CLASSIFICATION</b>		
	All specific use types within the Agriculture Primary Use Classification	1.25/1,000 sf GFA

\*See Section 10.4.5.4 for Shared Vehicle Parking Requirements

#### 10.4.4.6 Maximum Vehicle Surface Parking for Transit Oriented Development

##### A. Intent

To promote active, transit-supportive development and uses proximate to transit stations, thereby leveraging regional investment in transit infrastructure and promoting livability and sustainability in Denver’s transit neighborhoods.

##### B. Applicability

1. This Section 10.4.4.45 shall apply to all uses located within 1/4 mile of the outer boundary of a Rail Transit Station Platform in all zone districts except the CMP zone districts, ~~and~~
2. This Section 10.4.4.45 shall apply only to limit the amount of Surface Parking.
3. ~~If a structure or use is exempt from minimum parking requirements, this subsection’s maximum parking standard shall still apply, based on the minimum amount otherwise required by the underlying zone district for such use or structure absent any exemption or reduction:~~
  - a. ~~If the underlying zone district does not include minimum parking requirements, this subsection’s maximum parking standard shall still apply, based on the minimum requirement otherwise required for the subject use or uses in the C-MX Zone Districts.~~
4. All distance and spacing requirements shall be measured according to the rule of measurement found in Section 13.1.11, Measurement of Separation or Distance.

##### C. Shared Parking Where Maximum Parking Standards Apply

When located on a Zone Lot subject **only** to a vehicle Surface Parking maximum according to section 10.4.4.45, Maximum Vehicle Surface Parking for Transit Oriented Development, each shared vehicle Surface Parking space shall be counted **only once** in the calculation of vehicle Surface Parking spaces that contribute to the maximum allowed.

**D. Maximum Vehicle Surface Parking Permitted**

For all applicable zone districts where minimum maximum parking limits requirements apply, Surface Parking spaces shall not exceed the parking ratios in the following tables based on the allowed primary uses by neighborhood context and special context. 110 percent of the minimum the maximum parking spaces allowed required by the subject property's zone district, except that up to 1 vehicle surface parking space per dwelling unit shall be allowed even if exceeding the 110 percent maximum standard. For all applicable zone districts where maximum vehicle parking standards apply, the more restrictive standard shall determine the maximum vehicle Surface Parking allowed.

USE CATEGORY	SPECIFIC USE TYPE	NEIGHBORHOOD CONTEXT: Maximum Vehicle Surface Parking Permitted: # of spaces per unit of measurement					
		SUBURBAN	URBAN EDGE	URBAN	GENERAL URBAN	URBAN CENTER	DOWNTOWN EXCEPT D-CPV-T, D-CPV-R and D-CPV-C
<b>RESIDENTIAL PRIMARY USE CLASSIFICATION</b>							
Household Living	Dwelling, Single Unit	1/unit	1/unit	1/unit	1/unit	1/unit	1/unit
	Dwelling, Two Unit	MS only: 1.1/unit 1.375/unit	1.1/unit	1.1/unit	1.1/unit	CCN districts only: 1.1/unit All Others: 0.825/unit	0.825/unit
	Dwelling, Multi-Unit	MS only: 1.1/unit 1.375/unit	1.1/unit	1.1/unit	1.1/unit	CCN districts only: 1.1/unit All Others: 0.825/unit	0.825/unit
	Dwelling, Live / Work	MS only: 1.1/unit 1.375/unit	1.1/unit	1.1/unit	1.1/unit	CCN districts only: 1.1/unit All Others: 0.825/unit	0.825/unit
	Manufactured Home Community	1/unit	1/unit	1/unit	1/unit	1/unit	1/unit
Residential Care	Residential Care, Type 1	0.55/1,000 sf GFA	0.55/1,000 sf GFA	0.55/1,000 sf GFA	0.55/1,000 sf GFA	0.275/1,000 sf GFA	0.275/1,000 sf GFA
	Residential Care, Type 2	0.55/1,000 sf GFA	0.55/1,000 sf GFA	0.55/1,000 sf GFA	0.55/1,000 sf GFA	0.275/1,000 sf GFA	0.275/1,000 sf GFA
	Residential Care, Type 3	0.55/1,000 sf GFA	0.55/1,000 sf GFA	0.55/1,000 sf GFA	0.55/1,000 sf GFA	0.275/1,000 sf GFA	0.275/1,000 sf GFA
	Residential Care, Type 4	0.55/1,000 sf GFA	0.55/1,000 sf GFA	0.55/1,000 sf GFA	0.55/1,000 sf GFA	0.275/1,000 sf GFA	0.275/1,000 sf GFA
Congregate Living	All Types	1.1/1,000 sf GFA	1.1/1,000 sf GFA	1.1/1,000 sf GFA	1.1/1,000 sf GFA	0.55/1,000 sf GFA	0.275/1,000 sf GFA
<b>CIVIC, PUBLIC &amp; INSTITUTIONAL PRIMARY USE CLASSIFICATION</b>							
Basic Utilities	Utility, Major Impact	0.55/1,000 sf GFA	0.55/1,000 sf GFA	0.55/1,000 sf GFA	0.55/1,000 sf GFA	0.55/1,000 sf GFA	0.55/1,000 sf GFA
	Utility, Minor Impact	0.55/1,000 sf GFA	0.55/1,000 sf GFA	0.55/1,000 sf GFA	0.55/1,000 sf GFA	0.55/1,000 sf GFA	0.55/1,000 sf GFA

USE CATEGORY	SPECIFIC USE TYPE	NEIGHBORHOOD CONTEXT: Maximum Vehicle Surface Parking Permitted: # of spaces per unit of measurement					
		SUBURBAN	URBAN EDGE	URBAN	GENERAL URBAN	URBAN CENTER	DOWNTOWN EXCEPT D-CPV-T, D-CPV-R and D-CPV-C
Community/ Public Services	Community Center	0.55 / 1,000 sf GFA	0.55 / 1,000 sf GFA	0.55 / 1,000 sf GFA	0.55 / 1,000 sf GFA	0.55 / 1,000 sf GFA	0.55 / 1,000 sf GFA
	Day Care Center	1.1/ 1,000 sf GFA	1.1/ 1,000 sf GFA	1.1/ 1,000 sf GFA	1.1/ 1,000 sf GFA	1.1/ 1,000 sf GFA	1.1/ 1,000 sf GFA
	Postal Facility, Neighborhood	MS only: 2.2/1,000 sf GFA All Others: 2.75/1,000 sf GFA	MS only: 2.2/1,000 sf GFA All Others: 2.75/1,000 sf GFA	MS only: 2.2/1,000 sf GFA All Others: 2.75/1,000 sf GFA	2.06/1,000 sf GFA	CCN districts only: 2.75/1,000 sf GFA All Others: 1.375/1,000 sf GFA	1.375/1,000 sf GFA
	Postal Processing Center	1.1/1,000 sf GFA	1.1/1,000 sf GFA	1.1/1,000 sf GFA	1.1/1,000 sf GFA	1.1/1,000 sf GFA	1.1/1,000 sf GFA
	Public Safety Facility	1.1/1,000 sf GFA	1.1/1,000 sf GFA	1.1/1,000 sf GFA	1.1/1,000 sf GFA	1.1/1,000 sf GFA	1.1/1,000 sf GFA
	Hospital	No maximum limit					
	Correctional Institution	No maximum limit					
Cultural/Special Purpose/Public Parks & Open Space	Cemetery	No maximum limit					
	Library	1.1/1,000 sf GFA	1.1/1,000 sf GFA	1.1/1,000 sf GFA	1.1/1,000 sf GFA	1.1/1,000 sf GFA	1.1/1,000 sf GFA
	Museum	1.1/1,000 sf GFA	1.1/1,000 sf GFA	1.1/1,000 sf GFA	1.1/1,000 sf GFA	1.1/1,000 sf GFA	1.1/1,000 sf GFA
	City Park	No maximum limit					
	Open Space - Conservation	No maximum limit					
Education	Elementary or Secondary School	High School: 2.2/1,000 sf GFA All Others: 1.1/1,000 sf GFA	High School: 2.2/1,000 sf GFA All Others: 1.1/1,000 sf GFA	High School: 2.2/1,000 sf GFA All Others: 1.1/1,000 sf GFA	1.1/1,000 sf GFA	1.1/1,000 sf GFA	1.1/1,000 sf GFA
	University or College	1.1/1,000 sf GFA	1.1/1,000 sf GFA	1.1/1,000 sf GFA	1.1/1,000 sf GFA	1.1/1,000 sf GFA	1.1/1,000 sf GFA
	Vocational or Professional School	1.1/1,000 sf GFA	1.1/1,000 sf GFA	1.1/1,000 sf GFA	1.1/1,000 sf GFA	1.1/1,000 sf GFA	1.1/1,000 sf GFA
Public and Religious Assembly	All Types	0.55/1,000 sf GFA	0.55/1,000 sf GFA	0.55/1,000 sf GFA	0.55/1,000 sf GFA	0.55/1,000 sf GFA	0.55/1,000 sf GFA
<b>COMMERCIAL SALES, SERVICES, &amp; REPAIR PRIMARY USE CLASSIFICATION</b>							
Adult Business	All Types (where permitted by Adult Use Overlay District)	MS only: 2.2/1,000 sf GFA All Others: 2.75/1,000 sf GFA	MS only: 2.2/1,000 sf GFA All Others: 2.75/1,000 sf GFA	MS only: 2.2/1,000 sf GFA All Others: 2.75/1,000 sf GFA	2/1,000 sf GFA	1.375/1,000 sf GFA	1.375/1,000 sf GFA
Arts, Recreation & Entertainment	Arts, Recreation and Entertainment Services, Indoor	Artist Studio: 0.33/1000 sf GFA MS only: 2.2/1,000 sf GFA All Others: 2.75/1,000 sf GFA	Artist Studio: 0.33/1000 sf GFA MS only: 2.2/1,000 sf GFA All Others: 2.75/1,000 sf GFA	Artist Studio: 0.33/1000 sf GFA MS only: 2.2/1,000 sf GFA All Others: 2.75/1,000 sf GFA	Artist Studio: 0.33/1000 sf GFA All Others: 2.06/1,000 sf GFA	Artist Studio: 0.33/1000 sf GFA CCN districts only: 2.75/1,000 sf GFA All Others: 1.375/1,000 sf GFA	Artist Studio: 0.33/1000 sf GFA All Others: 1.375/1,000 sf GFA
	Arts, Recreation and Entertainment Services, Outdoor	MS only: 2.2/1,000 sf GFA All Others: 2.75/1,000 sf GFA	MS only: 2.2/1,000 sf GFA All Others: 2.75/1,000 sf GFA	MS only: 2.2/1,000 sf GFA All Others: 2.75/1,000 sf GFA	2.06/1,000 sf GFA	CCN districts only: 2.75/1,000 sf GFA All Others: 1.375/1,000 sf GFA	1.375/1,000 sf GFA
	Event Space with Alternate Parking and Loading Sports and/or Entertainment Arena or Stadium	No maximum limit					
Parking of Vehicles	Parking, Garage	No maximum limit					
	Parking, Surface	No maximum limit					

**Modernizing Parking Requirements  
LUTI Committee Review Draft  
May 13, 2025**

Article 10. General Design Standards  
Division 10.4 Parking and Loading

USE CATEGORY	SPECIFIC USE TYPE	NEIGHBORHOOD CONTEXT: Maximum Vehicle Surface Parking Permitted: # of spaces per unit of measurement					DOWNTOWN EXCEPT D-CPV-T, D-CPV-R and D-CPV-C	
		SUBURBAN	URBAN EDGE	URBAN	GENERAL URBAN	URBAN CENTER		
Eating & Drinking Establishments	All Types	MS only: 2.2/1,000 sf GFA All Others: 5.5/1,000 sf GFA	MS only: 2.2/1,000 sf GFA All Others: 4.95/1,000 sf GFA	MS only: 2.2/1,000 sf GFA All Others: 4.95/1,000 sf GFA	MS only: 2.2 / 1,000 sf GFA All Others: 4.125/1,000 sf GFA	MS only: 2.2/ 1,000 sf GFA All Others: 2.75/1,000 sf GFA	2.75/1,000 sf GFA	
Lodging Accommodations	Bed and Breakfast Lodging	1.1/guest room or unit	1.1/guest room or unit	1.1/guest room or unit	1.1/guest room or unit	0.96/guest room or unit	0.96/guest room or unit	
	Lodging Accommodations, All Others	1.1/guest room or unit	1.1/guest room or unit	1.1/guest room or unit	1.1/guest room or unit	0.55 guest room or unit	0.96/guest room or unit	
Office	Dental / Medical Office or Clinic	2.2/1,000 sf GFA	2.2/1,000 sf GFA	2.2/1,000 sf GFA	2.06/1,000 sf GFA	CCN districts only: 2.2/1,000 sf GFA All Others: 1.375/1,000 sf GFA	1.375/1,000 sf GFA	
	Office, All Others	2.2/ 1,000 sf GFA	2.2/ 1,000 sf GFA	2.2/ 1,000 sf GFA	2.06/1,000 sf GFA	CCN districts only: 2.2/1,000 sf GFA All Others: 1.375/1,000 sf GFA	1.375/1,000 sf GFA	
Retail Sales, Service & Repair (Not Including Vehicle or Equipment Sales, Service & Repair)	Animal Sales and Services, Household Pets Only	MS only: 2.2/1,000 sf GFA All Others: 2.75/1,000 sf GFA	MS only: 2.2/1,000 sf GFA All Others: 2.75/1,000 sf GFA	MS only: 2.2/1,000 sf GFA All Others: 2.75/1,000 sf GFA	2.06/1,000 sf GFA	CCN districts only: 2.75/1,000 sf GFA All Others: 1.375/1,000 sf GFA	1.375/1,000 sf GFA	
	Animal Sales and Services, All Others	No maximum limit						
	Food Sales or Market	MS only: 2.2/1,000 sf GFA All Others: 2.75/1,000 sf GFA	MS only: 2.2/1,000 sf GFA All Others: 2.75/1,000 sf GFA	MS only: 2.2/1,000 sf GFA All Others: 2.75/1,000 sf GFA	2.06/1,000 sf GFA	CCN districts only: 2.75/1,000 sf GFA All Others: 1.375/1,000 sf GFA	1.375/1,000 sf GFA	
Retail Sales, Service & Repair (Not Including Vehicle or Equipment Sales, Service & Repair)	Pawn Shop	No maximum limit	No maximum limit	No maximum limit	No maximum limit	No maximum limit	1.375/1,000 sf GFA	
	Retail Sales, Service & Repair - Outdoor	MS only: 2.2/1,000 sf GFA All Others: 2.75/1,000 sf GFA	MS only: 2.2/1,000 sf GFA All Others: 2.75/1,000 sf GFA	MS only: 2.2/1,000 sf GFA All Others: 2.75/1,000 sf GFA	No maximum limit	No maximum limit	1.375/1,000 sf GFA	
	Retail Sales, Service & Repair - Firearms Sales	MS only: 2.2/1,000 sf GFA All Others: 2.75/1,000 sf GFA	MS only: 2.2/1,000 sf GFA All Others: 2.75/1,000 sf GFA	MS only: 2.2/1,000 sf GFA All Others: 2.75/1,000 sf GFA	2.06/1,000 sf GFA	1.375/1,000 sf GFA	1.375/1,000 sf GFA	
	Retail Sales, Service & Repair, All Others	MS only: 2.2/1,000 sf GFA All Others: 2.75/1,000 sf GFA	MS only: 2.2/1,000 sf GFA All Others: 2.75/1,000 sf GFA	MS only: 2.2/1,000 sf GFA All Others: 2.75/1,000 sf GFA	2.06/1,000 sf GFA	CCN districts only: 2.75/1,000 sf GFA All Others: 1.375/1,000 sf GFA	1.375/1,000 sf GFA	
Vehicle / Equipment Sales, Rentals, Service & Repair	Automobile Emissions Inspection Facility	0.55/1,000 sf GFA	0.55/1,000 sf GFA	0.55/1,000 sf GFA	0.55/1,000 sf GFA	0.55/1,000 sf GFA	0.55/1,000 sf GFA	
	Automobile Services, Light	0.55/1,000 sf GFA	0.55/1,000 sf GFA	0.55/1,000 sf GFA	0.55/1,000 sf GFA	0.55/1,000 sf GFA	0.55/1,000 sf GFA	
	Automobile Services, Heavy	0.55/1,000 sf GFA	0.55/1,000 sf GFA	0.55/1,000 sf GFA	0.55/1,000 sf GFA	0.55/1,000 sf GFA	0.55/1,000 sf GFA	
	Automobile / Motorcycle / Light Truck Sales, Rentals, Leasing; Pawn Lot or Vehicle Auctioneer	0.55/1,000 sf GFA	0.55/1,000 sf GFA	0.55/1,000 sf GFA	0.55/1,000 sf GFA	0.55/1,000 sf GFA	0.55/1,000 sf GFA	
	Heavy Vehicle/ Equipment Sales, Rentals & Service	0.55/1,000 sf GFA	0.55/1,000 sf GFA	0.55/1,000 sf GFA	0.55/1,000 sf GFA	0.55/1,000 sf GFA	0.55/1,000 sf GFA	

USE CATEGORY	SPECIFIC USE TYPE	NEIGHBORHOOD CONTEXT: Maximum Vehicle Surface Parking Permitted: # of spaces per unit of measurement						DOWNTOWN EXCEPT D-CPV-T, D-CPV-R and D-CPV-C
		SUBURBAN	URBAN EDGE	URBAN	GENERAL URBAN	URBAN CENTER		
<b>INDUSTRIAL, MANUFACTURING &amp; WHOLESALE PRIMARY USE CLASSIFICATION</b>								
Communications and Information	Antennas Not Attached to a Tower	No maximum limit						
	Communication Services	0.55/1,000 sf GFA	0.55/1,000 sf GFA	0.55/1,000 sf GFA	0.55/1,000 sf GFA	0.55/1,000 sf GFA	0.55/1,000 sf GFA	
	Telecommunications Towers	No maximum limit						
	Telecommunications Tower - Alternative Structure	No maximum limit						
	Telecommunication Facilities - All Others	No maximum limit						
Industrial Services	Contractors, Special Trade - General	0.55/1,000 sf GFA	0.55/1,000 sf GFA	0.55/1,000 sf GFA	0.55/1,000 sf GFA	0.55/1,000 sf GFA	0.55/1,000 sf GFA	
	Contractors, Special Trade - Heavy/ Contractor Yard	No maximum limit						
	Food Preparation and Sales, Commercial	0.55/1,000 sf GFA	0.55/1,000 sf GFA	0.55/1,000 sf GFA	0.55/1,000 sf GFA	0.55/1,000 sf GFA	0.55/1,000 sf GFA	
Industrial Services	Laboratory, Research, Development and Technological Services	0.55/1,000 sf GFA	0.55/1,000 sf GFA	0.55/1,000 sf GFA	0.55/1,000 sf GFA	0.55/1,000 sf GFA	0.55/1,000 sf GFA	
	Service/Repair, Commercial	0.55/1,000 sf GFA	0.55/1,000 sf GFA	0.55/1,000 sf GFA	0.55/1,000 sf GFA	0.55/1,000 sf GFA	0.55/1,000 sf GFA	
Manufacturing and Production	Manufacturing, Fabrication & Assembly - Custom	0.55/1,000 sf GFA	0.55/1,000 sf GFA	0.55/1,000 sf GFA	0.55/1,000 sf GFA	0.55/1,000 sf GFA	0.55/1,000 sf GFA	
	Manufacturing, Fabrication & Assembly - General	0.55/1,000 sf GFA	0.55/1,000 sf GFA	0.55/1,000 sf GFA	No maximum limit	No maximum limit	0.55/1,000 sf GFA	
	Manufacturing, Fabrication & Assembly - Heavy	No maximum limit						
Mining & Extraction and Energy Producing Systems	Oil, Gas -- Production, Drilling	No maximum limit						
	Sand or Gravel Quarry	No maximum limit						
	Wind Energy Conversion Systems	No maximum limit						
Transportation Facilities	Airport	No maximum limit						
	Helipad, Helistop, Heliport	No maximum limit						
	Railroad Facilities	No maximum limit	No maximum limit	No maximum limit	No maximum limit	No maximum limit	0.55/1,000 sf GFA	
	Railway Right-of-Way	No maximum limit						
	Terminal, Station or Service Facility for Passenger Transit System	0.55/1,000 sf GFA	0.55/1,000 sf GFA	0.55/1,000 sf GFA	0.55/1,000 sf GFA	0.55/1,000 sf GFA	0.55/1,000 sf GFA	
	Terminal, Freight, Air Courier Services	No maximum limit	No maximum limit	No maximum limit	No maximum limit	No maximum limit	0.55/1,000 sf GFA	



USE CATEGORY	SPECIFIC USE TYPE	NEIGHBORHOOD CONTEXT: Maximum Vehicle Surface Parking Permitted: # of spaces per unit of measurement					
		SUBURBAN	URBAN EDGE	URBAN	GENERAL URBAN	URBAN CENTER	DOWNTOWN EXCEPT D-CPV-T, D-CPV-R and D-CPV-C
Waste Related Services	Automobile Parts Recycling Business	No maximum limit					
	Junkyard	No maximum limit					
	Recycling Center	No maximum limit					
	Recycling Collection Station	No maximum limit					
	Recycling Plant, Scrap Processor	No maximum limit					
	Solid Waste Facility	No maximum limit					
Wholesale, Storage, Warehouse & Distribution	Automobile Towing Service Storage Yard	No maximum limit					
	Mini-storage Facility	0.11/1,000 sf GFA	0.11/1,000 sf GFA	0.11/1,000 sf GFA	0.11/1,000 sf GFA	0.11/1,000 sf GFA	0.11/1,000 sf GFA
	Vehicle Storage, Commercial	0.55/1,000 sf GFA	0.55/1,000 sf GFA	No maximum limit	No maximum limit	No maximum limit	0.55/1,000 sf GFA
	Wholesale Trade or Storage, General	0.55/1,000 sf GFA	0.55/1,000 sf GFA	No maximum limit	No maximum limit	No maximum limit	No maximum limit
	Wholesale Trade or Storage, Light	0.55/1,000 sf GFA	0.55/1,000 sf GFA	0.55/1,000 sf GFA	0.55/1,000 sf GFA	0.55/1,000 sf GFA	0.55/1,000 sf GFA
<b>AGRICULTURE PRIMARY USE CLASSIFICATION</b>							
Agriculture	Aquaculture	No maximum limit					
	Garden, Urban	0.55/1,000 sf GFA	0.55/1,000 sf GFA	0.55/1,000 sf GFA	0.55/1,000 sf GFA	0.55/1,000 sf GFA	0.55/1,000 sf GFA
	Husbandry, Animal	No maximum limit					
	Husbandry, Plant	No maximum limit					
	Plant Nursery	0.55/1,000 sf GFA	0.55/1,000 sf GFA	0.55/1,000 sf GFA	0.55/1,000 sf GFA	0.55/1,000 sf GFA	0.55/1,000 sf GFA

USE CATEGORY	SPECIFIC USE TYPE	SPECIAL CONTEXT: Maximum Vehicle Surface Parking Permitted: # of spaces per unit of measurement				
		INDUSTRIAL	OPEN SPACE EXCEPT OS-A	O-1	MANUFACTURED HOME COMMUNITY	MASTER PLANNED
<b>RESIDENTIAL PRIMARY USE CLASSIFICATION</b>						
Household Living	Dwelling, Single Unit	1/unit	No maximum limit	No maximum limit	No maximum limit	1/unit
	Dwelling, Two Unit	I-MX only: 1.1/unit All Others: 1.375/unit	No maximum limit	No maximum limit	No maximum limit	1.1/unit
	Dwelling, Multi-Unit	I-MX only: 1.1/unit All Others: 1.375/unit	No maximum limit	No maximum limit	No maximum limit	1.1/unit
	Dwelling, Live / Work	I-MX only: 1.1/unit All Others: 1.375/unit	No maximum limit	No maximum limit	No maximum limit	1.1/unit
	Manufactured Home Community	1/unit	No maximum limit	No maximum limit	1/unit	No maximum limit

USE CATEGORY	SPECIFIC USE TYPE	SPECIAL CONTEXT: Maximum Vehicle Surface Parking Permitted: # of spaces per unit of measurement				
		INDUSTRIAL	OPEN SPACE EXCEPT OS-A	O-1	MANUFACTURED HOME COMMUNITY	MASTER PLANNED
Residential Care	Residential Care, Type 1	I-MX only: <u>0.275/1,000 sf GFA</u> All Others: <u>0.55/1,000 sf GFA</u>	No maximum limit	<u>0.275/1,000 sf GFA</u>	No maximum limit	<u>0.275/1,000 sf GFA</u>
	Residential Care, Type 2	I-MX only: <u>0.275/1,000 sf GFA</u> All Others: <u>0.55/1,000 sf GFA</u>	No maximum limit	<u>0.275/1,000 sf GFA</u>	No maximum limit	<u>0.275/1,000 sf GFA</u>
	Residential Care, Type 3	I-MX only: <u>0.275/1,000 sf GFA</u> All Others: <u>0.55/1,000 sf GFA</u>	No maximum limit	<u>0.275/1,000 sf GFA</u>	No maximum limit	<u>0.275/1,000 sf GFA</u>
	Residential Care, Type 4	I-MX only: <u>0.275/1,000 sf GFA</u> All Others: <u>0.55/1,000 sf GFA</u>	No maximum limit	<u>0.275/1,000 sf GFA</u>	No maximum limit	<u>0.275/1,000 sf GFA</u>
Congregate Living	All Types	I-MX only: <u>0.275/1,000 sf GFA</u> All Others: <u>0.55/1,000 sf GFA</u>	No maximum limit	<u>0.55/1,000 sf GFA</u>	No maximum limit	<u>0.55/1,000 sf GFA</u>
<b>CIVIC, PUBLIC &amp; INSTITUTIONAL PRIMARY USE CLASSIFICATION</b>						
Basic Utilities	Utility, Major Impact	<u>0.55/1,000 sf GFA</u>	<u>0.55/1,000 sf GFA</u>	<u>0.55/1,000 sf GFA</u>	No maximum limit	<u>0.55/1,000 sf GFA</u>
	Utility, Minor Impact	<u>0.55/1,000 sf GFA</u>	<u>0.55/1,000 sf GFA</u>	<u>0.55/1,000 sf GFA</u>	No maximum limit	<u>0.55/1,000 sf GFA</u>
Community/ Public Services	Community Center	<u>0.55/1,000 sf GFA</u>	<u>0.55/1,000 sf GFA</u>	<u>0.55/1,000 sf GFA</u>	No maximum limit	<u>0.55/1,000 sf GFA</u>
	Day Care Center	<u>1.1/1,000 sf GFA</u>	<u>1.1/1,000 sf GFA</u>	<u>1.1/1,000 sf GFA</u>	No maximum limit	<u>1.1/1,000 sf GFA</u>
	Postal Facility, Neighborhood	I-MX only: <u>2.06/1,000 sf GFA</u> All Others: <u>2.75/1,000 sf GFA</u>	No maximum limit	No maximum limit	No maximum limit	<u>2.06/1,000 sf GFA</u>
	Postal Processing Center	<u>1.1/1,000 sf GFA</u>	No maximum limit	No maximum limit	No maximum limit	<u>1.1/1,000 sf GFA</u>
	Public Safety Facility	<u>1.1/1,000 sf GFA</u>	<u>1.1/1,000 sf GFA</u>	<u>1.1/1,000 sf GFA</u>	No maximum limit	<u>1.1/1,000 sf GFA</u>
	Hospital	No maximum limit				
	Correctional Institution	No maximum limit	No maximum limit	<u>0.275/1,000 sf GFA</u>	No maximum limit	No maximum limit
Cultural/Special Purpose/Public Parks & Open Space	Cemetery	No maximum limit				
	Library	<u>1.1/1,000 sf GFA</u>	<u>1.1/1,000 sf GFA</u>	<u>1.1/1,000 sf GFA</u>	No maximum limit	<u>1.1/1,000 sf GFA</u>
	Museum	<u>1.1/1,000 sf GFA</u>	<u>1.1/1,000 sf GFA</u>	<u>1.1/1,000 sf GFA</u>	No maximum limit	<u>1.1/1,000 sf GFA</u>
	City Park	No maximum limit				
	Open Space - Conservation	No maximum limit				
Education	Elementary or Secondary School	I-MX only: <u>1.1/1,000 sf GFA</u> High School, I-A and I-B: <u>2.2/1,000 sf GFA</u> All Others, I-A and I-B: <u>1.1/1,000 sf GFA</u>	<u>1.1/1,000 sf GFA</u>	High School: <u>2.2/1,000 sf GFA</u> All Others: <u>1.1/1,000 sf GFA</u>	No maximum limit	<u>1.1/1,000 sf GFA</u>
	University or College	<u>1.1/1,000 sf GFA</u>	No maximum limit	No maximum limit	No maximum limit	<u>1.1/1,000 sf GFA</u>
	Vocational or Professional School	<u>1.1/1,000 sf GFA</u>	No maximum limit	No maximum limit	No maximum limit	<u>1.1/1,000 sf GFA</u>
Public and Religious Assembly	All Types	<u>0.55/1,000 sf GFA</u>	<u>0.55/1,000 sf GFA</u>	No maximum limit	No maximum limit	<u>0.55/1,000 sf GFA</u>

USE CATEGORY	SPECIFIC USE TYPE	SPECIAL CONTEXT: Maximum Vehicle Surface Parking Permitted: # of spaces per unit of measurement				
		INDUSTRIAL	OPEN SPACE EXCEPT OS-A	O-1	MANUFACTURED HOME COMMUNITY	MASTER PLANNED
<b>COMMERCIAL SALES, SERVICES, &amp; REPAIR PRIMARY USE CLASSIFICATION</b>						
Adult Business	All Types (where permitted by Adult Use Overlay District)	2.75/1,000 sf GFA	No maximum limit	No maximum limit	No maximum limit	2/1,000 sf GFA
Arts, Recreation & Entertainment	Arts, Recreation and Entertainment Services, Indoor	Artist Studio: 0.33/1000 sf GFA All Others - I-MX only: 2.06/1,000 sf GFA All Others: 2.75/1,000 sf GFA	Artist Studio: 0.33/1000 sf GFA All Others: 2.75/1,000 sf GFA	No maximum limit	No maximum limit	Artist Studio: 0.33/1000 sf GFA All Others: 2.06/1,000 sf GFA
	Arts, Recreation and Entertainment Services, Outdoor	I-MX only: 2.06/1,000 sf GFA 2.75/1,000 sf GFA	2.75/1,000 sf GFA	2.75/1,000 sf GFA	No maximum limit	2.06/1,000 sf GFA
	Event Space with Alternate Parking and Loading	No maximum limit				
	Sports and/or Entertainment Arena or Stadium	2.75/1,000 sf GFA	1.1/1,000 sf GFA	No maximum limit	No maximum limit	No maximum limit
Parking of Vehicles	Parking, Garage	No maximum limit				
	Parking, Surface	No maximum limit				
Eating & Drinking Establishments	All Types	I-MX only: 4.125/ 1,000 sf GFA All Others: 5.5/1,000 sf GFA	No maximum limit	No maximum limit	No maximum limit	4.125/1,000 sf GFA
Lodging Accommodations	Bed and Breakfast Lodging	I-MX only: 1.1/guest room or unit All Others: 1.375/guest room or unit	No maximum limit	No maximum limit	No maximum limit	1.1/guest room or unit
	Lodging Accommodations, All Others	I-MX only: 1.1/guest room or unit All Others: 1.375/guest room or unit	No maximum limit	No maximum limit	No maximum limit	1.1/ guest room or unit
Office	Dental / Medical Office or Clinic	I-MX only: 2.06/ 1,000 sf GFA All Others: 2.75/ 1,000 sf GFA	No maximum limit	No maximum limit	No maximum limit	2.06/1,000 sf GFA
	Office, All Others	I-MX only: 2.06/ 1,000 sf GFA All Others: 2.2/ 1,000 sf GFA	No maximum limit	No maximum limit	No maximum limit	2.06/1,000 sf GFA

USE CATEGORY	SPECIFIC USE TYPE	SPECIAL CONTEXT: Maximum Vehicle Surface Parking Permitted: # of spaces per unit of measurement				
		INDUSTRIAL	OPEN SPACE EXCEPT OS-A	O-1	MANUFACTURED HOME COMMUNITY	MASTER PLANNED
Retail Sales, Service & Repair (Not Including Vehicle or Equipment Sales, Service & Repair)	Animal Sales and Services, Household Pets Only	I-MX only: 2.06/1,000 sf GFA All Others: 2.75/1,000 sf GFA	No maximum limit	No maximum limit	No maximum limit	2.06/1,000 sf GFA
	Animal Sales and Services, All Others	I-MX only: 2.06/1,000 sf GFA All Others: 2.75/1,000 sf GFA	No maximum limit	No maximum limit	No maximum limit	2.06/1,000 sf GFA
	Food Sales or Market	I-MX only: 2.06/1,000 sf GFA All Others: 2.75/1,000 sf GFA	No maximum limit	No maximum limit	No maximum limit	2.06/1,000 sf GFA
	Pawn Shop	1.375/ 1,000 sf GFA	No maximum limit	No maximum limit	No maximum limit	No maximum limit
	Retail Sales, Service & Repair - Outdoor	I-MX only: 2.06/1,000 sf GFA All Others: 2.75/1,000 sf GFA	No maximum limit	No maximum limit	No maximum limit	2.06/1,000 sf GFA
	Retail Sales, Service & Repair - Firearms Sales	I-MX only: 2.06/1,000 sf GFA All Others: 2.75/1,000 sf GFA	No maximum limit	No maximum limit	No maximum limit	2.06/1,000 sf GFA
	Retail Sales, Service & Repair, All Others	I-MX only: 2.06/1,000 sf GFA All Others: 2.75/1,000 sf GFA	No maximum limit	No maximum limit	No maximum limit	2.06/1,000 sf GFA
Vehicle / Equipment Sales, Rentals, Service & Repair	Automobile Emissions Inspection Facility	0.55/1,000 sf GFA	No maximum limit	No maximum limit	No maximum limit	0.55/1,000 sf GFA
	Automobile Services, Light	0.55/1,000 sf GFA	No maximum limit	No maximum limit	No maximum limit	0.55/1,000 sf GFA
	Automobile Services, Heavy	0.55/1,000 sf GFA	No maximum limit	No maximum limit	No maximum limit	0.55/1,000 sf GFA
	Automobile / Motorcycle / Light Truck Sales, Rentals, Leasing; Pawn Lot or Vehicle Auctioneer	0.55/1,000 sf GFA	No maximum limit	No maximum limit	No maximum limit	0.55/1,000 sf GFA
	Heavy Vehicle/ Equipment Sales, Rentals & Service	0.55/1,000 sf GFA	No maximum limit	No maximum limit	No maximum limit	0.55/1,000 sf GFA
<b>INDUSTRIAL, MANUFACTURING &amp; WHOLESALE PRIMARY USE CLASSIFICATION</b>						
Communications and Information	Antennas Not Attached to a Tower	No maximum limit				
	Communication Services	0.33/1,000 sf GFA	No maximum limit	No maximum limit	No maximum limit	0.55/1,000 sf GFA
	Telecommunications Towers	0.33/1,000 sf GFA	No maximum limit	No maximum limit	No maximum limit	No maximum limit
	Telecommunications Tower - Alternative Structure	0.33/1,000 sf GFA	No maximum limit	No maximum limit	No maximum limit	No maximum limit
	Telecommunication Facilities - All Others	0.33/1,000 sf GFA	No maximum limit	No maximum limit	No maximum limit	No maximum limit

USE CATEGORY	SPECIFIC USE TYPE	SPECIAL CONTEXT: Maximum Vehicle Surface Parking Permitted: # of spaces per unit of measurement				
		INDUSTRIAL	OPEN SPACE EXCEPT OS-A	O-1	MANUFACTURED HOME COMMUNITY	MASTER PLANNED
Industrial Services	Contractors, Special Trade - General	0.33/1,000 sf GFA	No maximum limit	No maximum limit	No maximum limit	0.55/1,000 sf GFA
	Contractors, Special Trade - Heavy/ Contractor Yard	0.33/1,000 sf GFA	No maximum limit	No maximum limit	No maximum limit	No maximum limit
	Food Preparation and Sales, Commercial	0.33/1,000 sf GFA	No maximum limit	No maximum limit	No maximum limit	0.55/1,000 sf GFA
	Laboratory, Research, Development and Technological Services	0.33/1,000 sf GFA	No maximum limit	No maximum limit	No maximum limit	0.55/1,000 sf GFA
	Service/Repair, Commercial	0.33/1,000 sf GFA	No maximum limit	No maximum limit	No maximum limit	0.55/1,000 sf GFA
Manufacturing and Production	Manufacturing, Fabrication & Assembly - Custom	0.33/1,000 sf GFA	No maximum limit	No maximum limit	No maximum limit	0.55/1,000 sf GFA
	Manufacturing, Fabrication & Assembly - General	0.33/1,000 sf GFA	No maximum limit	No maximum limit	No maximum limit	0.55/1,000 sf GFA
	Manufacturing, Fabrication & Assembly - Heavy	0.33/1,000 sf GFA	No maximum limit	No maximum limit	No maximum limit	No maximum limit
Mining & Extraction and Energy Producing Systems	Oil, Gas - Production, Drilling	0.33/1,000 sf GFA	No maximum limit	0.33/ 1,000 sf GFA	No maximum limit	No maximum limit
	Sand or Gravel Quarry	0.33/1,000 sf GFA	No maximum limit	No maximum limit	No maximum limit	No maximum limit
	Wind Energy Conversion Systems	No maximum limit				
Transportation Facilities	Airport	No maximum limit				
	Helipad, Helistop, Heliport	0.33/1,000 sf GFA	No maximum limit	No maximum limit	No maximum limit	No maximum limit
	Railroad Facilities	0.33/1,000 sf GFA	No maximum limit	No maximum limit	No maximum limit	No maximum limit
	Railway Right-of-Way	0.33/1,000 sf GFA	No maximum limit	No maximum limit	No maximum limit	No maximum limit
	Terminal, Station or Service Facility for Passenger Transit System	0.33/1,000 sf GFA	No maximum limit	No maximum limit	No maximum limit	No maximum limit
	Terminal, Freight, Air Courier Services	0.33/1,000 sf GFA	No maximum limit	No maximum limit	No maximum limit	No maximum limit
Waste Related Services	Automobile Parts Recycling Business	0.33/1,000 sf GFA	No maximum limit	No maximum limit	No maximum limit	No maximum limit
	Junkyard	0.33/1,000 sf GFA	No maximum limit	No maximum limit	No maximum limit	No maximum limit
	Recycling Center	0.33/1,000 sf GFA	No maximum limit	No maximum limit	No maximum limit	No maximum limit
	Recycling Collection Station	0.33/1,000 sf GFA	No maximum limit	No maximum limit	No maximum limit	No maximum limit
	Recycling Plant, Scrap Processor	0.33/1,000 sf GFA	No maximum limit	No maximum limit	No maximum limit	No maximum limit
	Solid Waste Facility	0.33/1,000 sf GFA	No maximum limit	No maximum limit	No maximum limit	No maximum limit

USE CATEGORY	SPECIFIC USE TYPE	SPECIAL CONTEXT: Maximum Vehicle Surface Parking Permitted: # of spaces per unit of measurement				
		INDUSTRIAL	OPEN SPACE EXCEPT OS-A	O-1	MANUFACTURED HOME COMMUNITY	MASTER PLANNED
Wholesale, Storage, Warehouse & Distribution	Automobile Towing Service Storage Yard	0.33/ 1,000 sf GFA	No maximum limit	No maximum limit	No maximum limit	No maximum limit
	Mini-storage Facility	0.11/ 1,000 sf GFA	No maximum limit	No maximum limit	No maximum limit	0.11/ 1,000 sf GFA
	Vehicle Storage, Commercial	0.33/ 1,000 sf GFA	No maximum limit	No maximum limit	No maximum limit	No maximum limit
	Wholesale Trade or Storage, General	0.33/ 1,000 sf GFA	No maximum limit	No maximum limit	No maximum limit	0.55/ 1,000 sf GFA
	Wholesale Trade or Storage, Light	0.33/ 1,000 sf GFA	No maximum limit	0.55/ 1,000 sf GFA	No maximum limit	0.55/ 1,000 sf GFA
<b>AGRICULTURE PRIMARY USE CLASSIFICATION</b>						
Agriculture	Aquaculture	0.55/ 1,000 sf GFA	0.55/ 1,000 sf GFA	No maximum limit	No maximum limit	No maximum limit
	Garden, Urban	0.55/ 1,000 sf GFA	0.55/ 1,000 sf GFA	0.55/ 1,000 sf GFA	No maximum limit	0.55/ 1,000 sf GFA
	Husbandry, Animal	0.55/ 1,000 sf GFA	0.55/ 1,000 sf GFA	No maximum limit	No maximum limit	No maximum limit
	Husbandry, Plant	0.55/ 1,000 sf GFA	0.55/ 1,000 sf GFA	No maximum limit	No maximum limit	No maximum limit
	Plant Nursery	0.55/ 1,000 sf GFA	0.55/ 1,000 sf GFA	0.55/ 1,000 sf GFA	No maximum limit	0.55/ 1,000 sf GFA

**10.4.4.7 Location of Required Vehicle Parking**

Required vehicle parking spaces shall be located on the same zone lot as the primary use for which provided, except as allowed below:

- A. As allowed in Section 10.4.5.4, Shared Vehicle Parking, or
- B. **Off-Site Vehicle Parking**

A primary use's required vehicle parking may be located on a Zone Lot different from the Zone Lot containing the primary use ("off-site vehicle parking"), subject to compliance with the following standards:

1. The subject Primary Use may provide off-site vehicle parking provided that the parking spaces on the off-site Zone Lot are not required vehicle parking spaces for any other Primary Use(s) (See Section 10.4.5.4, Shared Vehicle Parking, for that scenario):
2. Parking requirements may be met off the zone lot by ownership or a current lease of parking spaces on another zone lot and dedicated to the primary use being served. Divesting ownership or terminating lease of the required parking spaces shall result in termination of the zoning permit until the parking deficiency is remedied.
3. Off-site parking shall be located within a "walking distance" of 1,500 feet from the use served by the remote parking. "Walking distance" shall be measured from the primary entrance of the primary use served along a connection that meets ADA requirements.

Figure 10.4-1

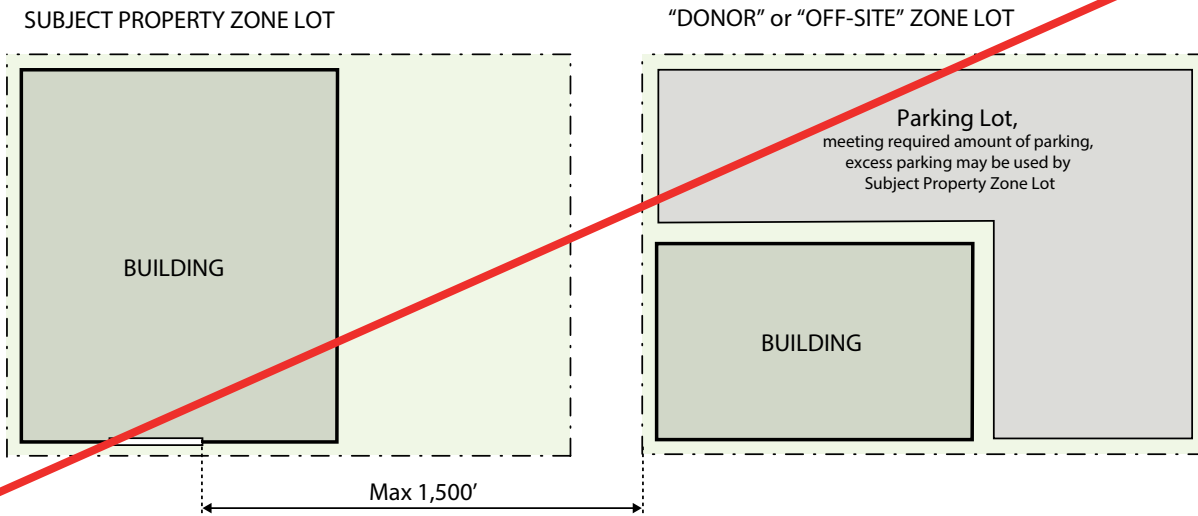

## ~~SECTION 10.4.5.....VEHICLE PARKING EXEMPTIONS AND REDUCTIONS~~

### ~~10.4.4.8 Vehicle Parking Exemptions~~

~~The following uses and circumstances are exempt from providing the minimum amount of vehicle parking otherwise required by this Code, but only to the extent specified in this Section.~~

#### ~~A. Pre-Existing Small Zone Lots~~

##### ~~1. Intent~~

~~Encourage the preservation of pre-existing Small Zone Lots through exempted vehicle parking requirements to facilitate the reuse of existing buildings and/or the redevelopment of Small Zone Lots.~~

##### ~~2. Applicability~~

- ~~a. All Mixed Use Commercial Zone Districts; and~~
- ~~b. Where the subject Zone Lot is currently equal to or smaller than 6,250 square feet and was equal to or smaller than 6,250 square feet on June 25, 2010 ("Small Zone Lot").~~

##### ~~3. Exemption Allowed~~

###### ~~a. Reuse of Existing Buildings on Small Zone Lots~~

- ~~i. If a building (1) is located on a Small Zone Lot and (2) existed on March 23, 2017, then of all uses in such building, including any modifications, alterations, and expansions, shall be exempt from providing vehicle parking.~~
- ~~ii. Any building located on a Small Zone Lot that is Voluntarily Demolished shall not be considered an existing building.~~

###### ~~b. New Buildings on Small Zone Lots Located within Proximity to Transit Service~~

~~All uses housed in the lowest two stories entirely above the base plane of a new building constructed on a Small Zone Lot located within 1/2 mile of the outer boundary of a Rail Transit Station Platform or located within 1/4 mile from a High-Frequency Transit Corridor may be exempt from providing vehicle parking. The Zoning Administrator shall determine whether a Small Zone Lot is within proxim-~~

ity to transit service as specified in Section 13.1.11, Measurement of Separation or Distance.

**c. New Buildings on All Other Small Zone Lots**

All uses housed in the first story that is entirely above the base plane of a new building constructed on any other Small Zone Lot may be exempt from providing vehicle parking.

**d. Vehicle Parking Exceptions for Required Vehicle Parking on Small Zone Lots**

- i. All exceptions to minimum vehicle parking requirements set forth in Section 10.4.5, Vehicle Parking Exemptions and Reductions, are available to any required minimum vehicle parking not exempted as described in this Section 10.4.5.1.A.
- ii. The total number of vehicle parking spaces required may be reduced by up to 100% under any one or combination of the vehicle parking reductions provided in accordance with Section 10.4.5.3, Vehicle Parking Reductions.

**B. Ground-Floor Retail Uses in Mixed Use Projects**

**1. Applicability**

- a. All Mixed Use Commercial Zone Districts, except MS-2, MS-2x, MX-2, MX-2x, MX-2A;
- b. Multi-story mixed use buildings; and
- c. Where one or more of the following uses is located on the ground floor:
  - i. Retail sales, service, or repair uses, provided no single retail sales, service, or repair use is more than 10,000 square feet of gross floor area;
  - ii. Food sales or market, provided no single food sales or market use is more than 10,000 square feet of gross floor area; or
  - iii. Eating or drinking establishment, provided no single eating or drinking establishment is more than 3,500 square feet of gross floor area.

**2. Exemption Allowed**

A maximum of 5,000 square feet of gross floor area of the uses listed in Section 10.4.5.1.B.1.c above per building shall be exempt from vehicle parking requirements.

**C. Historic Structures**

1. Required parking for Historic Structures shall be the lesser of the following:
  - a. The number of parking spaces required for the land use and located on site as of August 1, 2007, or for structures designated after August 1, 2007, as of the date of designation; or
  - b. The number of parking spaces required for the land use under this Code.
2. Parking spaces required to serve the Historic Structure that are located off of the zone lot as of August 1, 2007, need not be retained unless the provision of off-site parking spaces is a condition resulting from the quasi-judicial decision of the city council (e.g., as a condition or waiver attached to a rezoning approval).
3. Additions to Historic Structures shall be parked in accordance with this Division, and may be eligible for exemption according to Section 10.4.2.3.B, Exceptions for Expansion and Change of Use. The parking spaces for an addition to a Historic Structure are in addition to the number of parking spaces required according to Section 10.4.5.1.C.1 above. Off



~~street parking requirements for the addition may be met off of the zone lot according to Section 10.4.4.5.B, Off-Site Vehicle Parking.~~

4. ~~In the D-LD zone district, this subsection 10.4.5.1.C. shall have no force and effect, and Section 8.4.1.4, Off-Street Parking Requirements, shall govern the parking of Historic Structures.~~

**D. Preservation of Existing Trees**

~~If, in order to comply with standards in this Article 10 for the landscaping of parking areas and with this Division 10.4. Parking and Loading, it would be necessary to remove mature, existing trees, the Zoning Administrator may allow reasonable reductions in either (1) the size of required landscaped areas (for the purpose of accommodating the required parking), or (2) the number of required parking spaces. Requests for this exception from the minimum parking requirements shall be reviewed according to Section 12.4.5, Administrative Adjustment.~~

**E. Enhanced Affordable Housing near Multi-Modal Transportation**

**1. Intent**

~~To remove barriers to mixed income development by eliminating vehicle parking requirements for projects that are near high- or medium-capacity transit and provide enhanced affordable housing beyond mandatory requirements.~~

**2. Applicability**

- a. ~~This Section 10.4.5.1.E shall apply to Zone Lots that meet the following criteria:~~
  - i. ~~Have their nearest point within 1/4 mile of the outer boundary of a Rail Transit Station Platform or within 1/4 mile of a High/Medium-Capacity Transit Corridor; and~~
  - ii. ~~Are located in a Mixed Use Commercial Zone District, Multi Unit (MU) zone district, Residential Office (RO) zone district, or Residential Mixed Use (RX) zone district.~~
- b. ~~All distance and spacing requirements shall be measured according to the rule of measurement found in Section 13.1.11 Measurement of Separation or Distance.~~

**3. Exemption**

~~All Dwelling Units on a Zone Lot shall be exempt from the minimum amount of vehicle parking otherwise required by this Code if the Structure qualifies for the incentives for enhanced on-site compliance as set forth in D.R.M.C. Chapter 27, Article X Mandatory Affordable Housing and any applicable Rules and Regulations.~~

**10.4.4.9 Alternative Minimum Vehicle Parking Ratios**

~~The following uses are allowed alternative minimum vehicle parking ratios instead of the minimum parking ratios otherwise required by this Code, but only to the extent specified in this Section 10.4.5.2.~~

**A. General Provisions Applicable to All Alternative Minimum Vehicle Parking Ratios**

**1. No Combination with Reductions**

~~A vehicle parking reduction permitted in accordance with Section 10.4.5.3 shall not be taken in combination with use of an alternative minimum vehicle parking ratio provided in Section 10.4.5.2.~~

- a. For example: A Zone Lot in a Main Street zone district includes 100 housing units that are affordable at 60 percent Area Median Income and below, and office Primary Uses. The housing use may apply the affordable housing alternative minimum vehicle parking ratio of 0.1 vehicle parking spaces per unit for a parking requirement of 10 required vehicle parking spaces. The vehicle parking requirement for the office Primary Use may be reduced in accordance with the vehicle parking reductions provided in Section 10.4.5.3, Vehicle Parking Reductins, but the alternative minimum vehicle parking requirement for the affordable housing units may not be reduced further.

**2. Combination of Multiple Alternative Ratios Allowed**

If more than one alternative parking ratio applies to an applicable use(s), an Applicant may choose which alternative parking ratio to apply or may combine multiple alternative parking ratios in the same development.

- a. For example, in a Main Street zone district, a new primary structure will include 80 housing units that are affordable at 60 percent area median income and below, and another 50 housing units that are market-rate rentals but are each under 550 square feet in gross floor area. In this case, the applicant may apply the affordable housing alternative parking ratio to the 80 affordable units, and the small dwelling units alternative parking ratio to the 50 small units.

**B. Alternative Minimum Vehicle Parking Ratios Allowed**

The Zoning Administrator shall allow an applicant to apply an alternative minimum vehicle parking ratio upon finding that the additional requirements stated in the following table have been met:

TYPE OF ALTERNATIVE	APPLICABLE ZONE DISTRICTS	APPLICABLE USE	ADDITIONAL REQUIREMENTS	ALTERNATIVE ALLOWED
Affordable Housing	All Zone Districts	Primary Residential Uses	Housing that is affordable at 60 percent Area Median Income and below	Alternative minimum vehicle parking ratio of 0.1 vehicle parking spaces per unit
Mandatory Affordable Housing On-Site Compliance	All Zone Districts	Primary Residential Uses	All required Income Restricted Units are located on the Zone Lot	Alternative minimum vehicle parking ratio for all Dwelling Units of 0.75 vehicle parking spaces per unit in Suburban (S) and Industrial (I) contexts; 0.5 vehicle parking spaces per unit in Urban Edge (E), Urban (U), and General Urban (G) contexts; and 0.25 vehicle parking spaces per unit in Urban Center (C) context
Small Dwelling Units	All Main Street Zone Districts	Primary Residential Uses	Dwelling Units that are under 550 square feet in gross floor area may utilize this reduction	Alternative minimum vehicle parking ratio of 0.25 vehicle parking spaces per unit

TYPE OF ALTERNATIVE	APPLICABLE ZONE DISTRICTS	APPLICABLE USE	ADDITIONAL REQUIREMENTS	ALTERNATIVE ALLOWED
Shelters	All Zone Districts	Primary Residential Care Use	Residential Care Uses that provide temporary housing or shelter primarily to guests who are at risk of homelessness or are experiencing homelessness.	Alternative minimum vehicle parking ratio of 0.125 vehicle parking spaces per 1,000 sf GFA
Congregate Living	All Main Street Zone Districts	Congregate Living Primary Use	n/a	Alternative minimum vehicle parking ratio of 0.25 vehicle parking spaces per unit
Household Living for Older Adults	All Main Street Zone Districts	Household Living Primary Use	Dwelling unit must be occupied only by older adults (individuals 55 or more years of age) who comprise a single, non-profit housekeeping unit, and do not meet the definition of a "Residential Care Use."	Alternative minimum vehicle parking ratio of 0.25 vehicle parking spaces per unit
Other Housing	All Main Street Zone Districts	Primary Residential Uses	Other special needs housing with similar reduced parking demands, as approved by the Zoning Administrator	Alternative minimum vehicle parking ratio of 0.25 vehicle parking spaces per unit

**10.4.4.10 Vehicle Parking Reductions**

**A. General Provisions Applicable to All Vehicle Parking Reduction Allowances**

**1. Calculation**

In determining the total number of required vehicle parking spaces that may be reduced through any one or combination of this Section's permitted reductions, calculations shall be based on the minimum number of required vehicle parking spaces using the ratio contained in the applicable Use and Parking Table, and not based an alternative minimum vehicle parking ratio pursuant to Section 10.4.5.2, Alternative Minimum Vehicle Parking Ratios.

**2. No Combination with Alternative Minimum Vehicle Parking Ratios**

A vehicle parking reduction permitted in accordance with Section 10.4.5.3 shall not be taken in combination with use of an alternative minimum vehicle parking ratio provided in Section 10.4.5.2:

- a. For example: A Zone Lot in a Main Street zone district includes 100 housing units that are affordable at 60 percent Area Median Income and below, and office Primary Uses. The housing use may apply the affordable housing alternative minimum vehicle parking ratio of 0.1 vehicle parking spaces per unit for a parking requirement of 10 required vehicle parking spaces. The vehicle parking requirement for the office Primary Use may be reduced in accordance with the vehicle parking reductions provided in Section 10.4.5.3, but the alternative minimum vehicle parking requirement for the affordable housing units may not be reduced further.

**3. Maximum Reduction Allowed**

- a. The total number of vehicle parking spaces required on a zone lot shall not be reduced by more than 50% under any one or combination of this subsection's permitted reductions, with the following exceptions:
  - i. Vehicle parking reductions provided in Section 10.4.5.3.C, Vehicle Parking Reduction for Small Lots in the C-CGN Zone Districts.
  - ii. Vehicle parking reductions provided in Section 11.10.14.3.C, Flexibility for Outdoor Gathering Areas.

- b. Vehicle parking spaces provided through the alternative vehicle parking ratios in Section 10.4.5.2 do not count towards the maximum percentage of vehicle parking spaces that may be reduced through this subsection's permitted reductions.
  - i. **For example**, a Zone Lot in a G-MS-5 zone district includes 100 housing units that are affordable at 60 percent Area Median Income and below, and office Primary Uses. The housing use may apply the alternative minimum vehicle parking ratio of 0.1 vehicle parking spaces per unit for a parking requirement of 10 required vehicle parking spaces. The alternative minimum vehicle parking ratio for the affordable housing units is a 90% reduction from the 1 vehicle parking space per unit requirement in the G-MS-5 zone district, but alternative minimum vehicle parking ratios do not count towards the maximum percentage of vehicle parking spaces that may be reduced for the entire Zone Lot through Section 10.4.5.3.A.3, Maximum Reduction Allowed. Therefore, the minimum vehicle parking requirement for the office Primary Use may be reduced in accordance with the vehicle parking reductions in Section 10.4.5.3, Vehicle Parking Reductions, but the alternative minimum vehicle parking requirement for the affordable housing units may not be reduced further.—

**4. Informational Notice Required**

A request for a reduction greater than 25% in the required amount of parking shall be reviewed according to Section 12.4.2, Zoning Permit Review with Informational Notice.

**5. Withdrawal from Participation in Plans or Programs**

- a. Upon application to the Zoning Administrator, the owners of the properties and land uses participating in a special parking arrangement authorized by this Section 10.4.5.3, may withdraw, either partially or completely, from any such arrangement or program, provided all uses, land, and structures remaining under such arrangement or program will comply with all conditions and limitations of the arrangement or program, and all primary uses, land and structures withdrawn from such arrangement or program can comply with this Division 10.4 and the applicable zone district parking requirements. The Zoning Administrator shall keep the special parking arrangement/program withdrawal among its records and record the withdrawal in the Denver County real property records.
- b. The Zoning Administrator may allow withdrawal from a special parking arrangement authorized by this Section 10.4.5.3 to result in a permanent deficiency of the required amount of parking spaces that was otherwise allowed as part of the special parking arrangement if:
  - i. The owner(s) demonstrate that best efforts, as determined by the Zoning Administrator, were made to maintain and continue the authorized special parking arrangement; or,
  - ii. By no fault of the owner(s), the justification or factual basis for the reduction no longer applies or exists. Example, the relocation of a Multi-Modal Transportation stop, where the subject property is no longer within the requisite proximity to receive a parking reduction.

**B. Reductions Allowed**

The Zoning Administrator shall allow an applicant to apply reductions to the minimum number of required vehicle parking spaces upon finding that the additional requirements and special review process stated in the following table have been met:

TYPE OF REDUCTION	APPLICABLE ZONE DISTRICTS	APPLICABLE USE	ADDITIONAL REQUIREMENTS	REDUCTION ALLOWED	SPECIAL REVIEW PROCESS
<b>Assisted Living Facility</b>	All Zone Districts	Assisted Living-Primary-Use	The reduction shall be allowed only upon finding that the assisted living facility generates less parking need or demand due to the specific nature and character of the facility, its occupants, and/or visitors; and If a reduction is permitted under this provision, no additional parking reduction otherwise available under this Code shall be granted	0.5 space per unit reduction in the total number of required vehicle parking spaces	Section 12.4.2; Zoning Permit with Informational Notice
<b>Proximity to Multi-Modal Transportation</b>	Suburban (S)-, Urban Edge (E)-, Urban (U)-, or General Urban (G)-, Industrial (I)-, or Master Planned (M)- Zone District	Any Primary-Use	Any Primary Use located on a Zone Lot having its nearest point within 1/4 mile of the outer boundary of a Rail Transit Station Platform or 1/4 mile of a transit priority street as defined in Blueprint Denver	25% reduction in the total number of required vehicle parking spaces	See Section 10.4.5.3.A.4
<b>On-Site Car Sharing</b>	All Zone Districts, except Campus Zone Districts	Any Residential-Primary-Use	Where an active car-sharing program is available in the same building or on the same zone lot as that Primary Use and is made available to the residents in the same building where the residential units are located	5 required vehicle parking spaces reduced for each 1-car share space provided	See Section 10.4.5.3.A.4
	Campus Zone Districts	Any Primary-Use			
<b>Off-Site Car Sharing</b>	All Zone Districts	Any Primary-Use	The car sharing program shall be: (1) Located on a zone lot and not within public right-of-way; (2) Located within a walking distance no greater than 1,500' of the zone lot containing the subject primary use; (3) Either in existence or being developed concurrently with the proposed development; and (4) Has the capacity to meet a portion of the vehicle parking needs of the subject primary use	Determined by the Zoning Administrator	See Section 10.4.5.3.A.4
<b>Bike Sharing</b>	All Zone Districts, except Campus Zone Districts	Any Nonresidential Use	The bike share program shall be located in the same building, on the same zone lot, or in the public right-of-way abutting the subject zone lot.	1 required vehicle parking space reduced for each 5-bike share parking spaces provided	See Section 10.4.5.3.A.4
	Campus Zone Districts	Any Primary-Use			

**C. Vehicle Parking Reduction for Small Lots in the C-CCN Zone Districts**

1. In the C-CCN zone districts, zone lots which are equal to or smaller than 9,375 square feet in area on October 27, 2014, shall be granted a 67 percent reduction in the total number of required vehicle parking spaces.

2. This vehicle parking reduction shall not be allowed in combination with any vehicle parking reduction allowed under section 10.4.5.3.B, Reductions Allowed.

#### **10.4.4.11 Shared Vehicle Parking**

##### **A. Applicability**

1. An applicant may request shared parking to meet the minimum/maximum vehicle parking requirements for mixed-use developments, or for multiple uses that are located near one another, and which have different peak parking demands and/or operating hours.
2. Parking spaces that may be shared according to this subsection:
  - a. Shall be located on a zone lot (on-street parking spaces are not eligible), and
  - b. Shall be capable of being specifically allocated or reserved for the primary uses served (spaces in a surface lot or garage that are accessible by the general public are not eligible), except that this provision shall not apply in areas where only maximum parking standards apply;
  - c. However, in the event that a shared parking entity has been formed and is fully operational, the documented parking spaces allocated to the zone lot will count toward the vehicle parking requirement. Although allocated to a specified zone lot, said spaces need not be reserved for said specified zone lot.

##### **B. Shared Parking Where Maximum Parking Standards Apply**

1. When located on a Zone Lot subject only to a vehicle Surface Parking maximum according to section 10.4.4.4, Maximum Vehicle Surface Parking for Transit Oriented Development, each shared vehicle Surface Parking space shall be counted only once in the calculation of vehicle Surface Parking spaces that contribute to the maximum allowed.
2. When shared vehicle parking is required for a change of use according to Section 10.4.2.3.C, the number of shared spaces provided may exceed the number required to be shared according to that section. Shared spaces shall be counted only once in the calculation of the number of spaces that contribute to the maximum parking allowed for each Primary Use included in the parking analysis.
3. In all other areas subject to maximum vehicle parking standards the following shall apply:
  - a. Parking may be shared between Primary Uses located on separate Zone Lots according to this subsection.
  - b. Surface Parking and/or Garage Parking shall only be permitted as a Primary Use on a Zone Lot if the spaces are provided as shared vehicle parking according to this subsection.

##### **C. Shared Amount Allowed**

The Zoning Administrator shall determine the total amount of parking allowed to be shared based upon the shared parking analysis.

##### **D. Process for Review and Approval**

Requests for shared parking shall be processed according to Section 12.4.3, Site Development Plan Review. In addition to the requirements for a Site Development Plan, requests for shared parking shall comply with this Section's standards and criteria.

##### **E. Shared Parking Analysis Required**

A parking analysis shall be submitted as part of the Site Development Plan application which clearly establishes that the subject uses will use the shared parking spaces at different times of the day, week, month, or year. The analysis shall reference a shared parking study prepared by a Qualified Professional. A shared parking study shall, at a minimum, address:

1. ~~The intensity and type of activities and the composition of uses;~~
2. ~~Hours of operation of the uses;~~
3. ~~The rate of turnover for proposed shared spaces;~~
4. ~~Distances of shared parking spaces from the uses they serve; and~~
5. ~~The anticipated peak parking and traffic loads for the site.~~
6. ~~Parking spaces reserved for a specific tenant or dwelling unit shall not be included in the shared parking calculation.~~
7. ~~In areas subject to minimum parking requirements, if the shared parking spaces are located on a different zone lot than the primary use(s) served, such off-site spaces shall be located within a walking distance no greater than 1,500 feet from the use served. This provision shall not apply in areas where only maximum parking standards apply.~~
  - a. ~~“Walking distance” shall be measured from the primary entrance of the primary use served along a connection that meets ADA requirements.~~
  - b. ~~The Zoning Administrator may increase the allowed distance or waive the standard entirely when there is a shared parking entity and support in the shared parking analysis.~~
8. ~~In areas subject to maximum parking requirements, when multiple off-site Primary Uses are included, the number of shared spaces shall be specified for each off-site Primary Use contributing to the maximum parking allowed.~~

**F. ~~Withdrawal from Participation in Plans or Programs~~**

1. ~~Upon application to the Zoning Administrator, the owners of the properties and land uses participating in a special parking arrangement authorized by this Section 10.4.5.4 may withdraw, either partially or completely, from any such arrangement or program, provided all uses, land, and structures remaining under such arrangement or program will comply with all conditions and limitations of the arrangement or program, and all primary uses, land and structures withdrawn from such arrangement or program can comply with this Division and the applicable zone district parking requirements. The Zoning Administrator shall keep the special parking arrangement/program withdrawal among its records and record the withdrawal in the Denver County real property records.~~
2. ~~The Zoning Administrator may allow withdrawal from a special parking arrangement authorized by this Section 10.4.5.4 to result in a permanent deficiency of the required amount of parking spaces that was otherwise allowed as part of the special parking arrangement if the owner(s) demonstrates that best efforts, as determined by the Zoning Administrator, were made to maintain and continue the authorized special parking arrangement.~~

## SECTION 10.4.5 VEHICLE PARKING DESIGN

### 10.4.5.1 Vehicle Parking Layout - Single-Unit and Two-Unit Development

#### A. Intent

The intent of these standards is to ensure adequate space for vehicle maneuvering when entering or exiting carports and garages.

#### B. Applicability

This Subsection 10.4.6.1 shall apply to all Off-Street Parking Areas for all Single-Unit and Two-Unit Dwelling development.

#### C. Parking Space Standard

All **required** parking spaces shall have a minimum width of 8.5 feet and a minimum length of 17.5 feet.

#### D. Garage and Carport - Minimum Vehicle Maneuvering Area

1. Garage doors or Carport openings that do not open directly to a street or public or private Alley shall provide a minimum distance of 21 feet of maneuvering area as measured perpendicular from the face of the garage door or Carport opening. (See Figure 10.4-2)
2. When Garage doors or Carport openings are facing alley, Garage doors or Carport openings that open directly to a street or public or private Alley shall be located a minimum distance of 5 feet from the nearest right-of-way or private Alley boundary line as measured perpendicular from the face of the garage door or carport opening.
3. Garage doors or Carport openings that open directly to a private or public Alley shall be located a minimum distance of 21 feet from the farthest public or private Alley boundary line as measured perpendicular from the face of the garage door or carport opening.

Figure 10.4-2

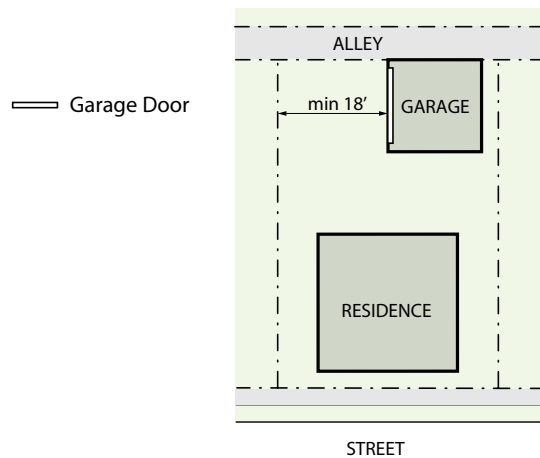
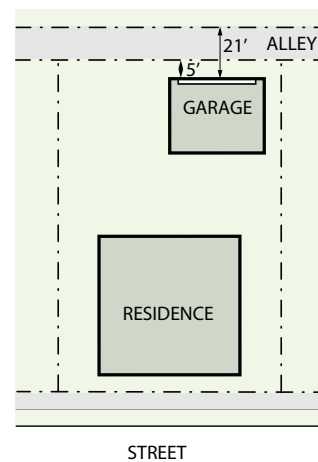

Figure 10.4-3



#### E. Other Standards

1. See Section 10.4.6.3.B, Vehicular Access
2. See Section 10.4.6.4.A, Drainage and Surface Materials



### 10.4.5.2 Vehicle Parking Layout - All Other Development

#### A. Applicability

1. This Subsection 10.4.6.2 shall apply to all All Off-Street Parking Areas except for Single-Unit and Two-Unit Dwelling development and except that mechanized parking spaces are exempt from the parking dimensions standards.
2. This Subsection 10.4.6.2 shall not apply to any portion of a zone lot that is established as an Event Space with Alternate Parking and Loading use within the CMP-NWC-G or CMP-NWC-F zone districts.
3. This Subsection 10.4.6.2 shall not apply in the MHC zone district.

#### B. Parking Space and Module Standards

Off-street parking spaces shall be laid out in accordance with the standards shown in Table A and Figure 10.4-4, with the following additions and exceptions:

##### 1. Parking Angle

- a. Parking angles greater than 0 degrees and less than 30 degrees are not allowed.
- b. Other angles between 30 and 90 degrees are allowed and the dimensions for those angles shall be determined through interpolation.
- c. Parking angles for spaces within individual garage units shall be determined by the angle of the entry to the garage structure.

##### 2. Parking Aisle

- a. A minimum of 5 feet of back out space shall be provided at ends of parking rows unless the aisle is 30 feet or more in width.
- b. If a public alley is allowed to be used as the aisle or access to adjoining parking spaces or garages, the spaces or projection must be lengthened as necessary to provide a total alley or aisle width of 20 feet for 30-degree through 75-degree angle parking and 23 feet for 90-degree angle parking. This requirement shall apply to all new uses and developments except single-unit and two-unit dwellings.

##### 3. Garage Door Setbacks

When a public alley is allowed to be used as the access to a parking garage, any garage door that faces the alley shall be setback at least 5 feet from the zone lot line abutting the public alley.

##### 4. Compact Spaces

- a. ~~No more than 10 percent of the total parking spaces provided (required and excess spaces) may be compact.~~
- b. ~~When provided in a parking garage, compact spaces may be used only where the layout of the structure requires such spaces at the end of a row or to accommodate a column.~~
- c. ~~All compact parking spaces shall be clearly and visibly striped and labeled (e.g., by a sign) for compact car use only.~~

##### 5. Measurements

- a. In a parking structure, stall dimensions shall be measured from the surface of an adjacent pillar, post, or column closest to the parking stall.

2. Two parking spaces in tandem shall have a combined minimum dimension of 8.5 feet in width and 35 feet in length.
3. It must be possible to get any vehicle in or out of a tandem space by moving only 1 vehicle.

#### **10.4.5.7 Packed Parking**

Packed parking, where it can provide more efficient surface parking through the reduction of maneuvering area when an attendant or mechanical parking system is used to park vehicles, is allowed subject to compliance with the following standards:

- A. An attendant or mechanical parking system shall be provided to park vehicles during all business hours of the primary use.
- B. All maneuvering, stacking, parking and loading for packed parking must be accomplished on private property.
- C. Except when a mechanized parking system is used, the area of each packed parking space shall be no less than 150 square feet. The minimum 150 square feet dimension may be reduced if the Zoning Administrator finds the reduction results in a more efficient layout of the packed parking area.

#### **10.4.5.8 Attendant Shelters or Pay Stations**

An attendant shelter or pay station may be provided on the same zone lot as a surface parking lot. If provided, an attendant shelter or pay station shall comply with the building form standards in the applicable zone district, as applicable, in addition to the following design standards. In case of any conflict with an applicable building form standard, the building form standard shall apply .

- A. Maximum Number of Attendant Shelters Permitted: 1 attendant shelter building.
- B. Maximum Number of Pay Stations Permitted: 1 pay station for each 50 surface parking spaces.
- C. Minimum Setback: An attendant shelter shall be setback a minimum of 20 feet from any boundary of the surface parking lot abutting a Protected zone district.

#### **10.4.5.9 Reference to Other Applicable Design Standards**

##### **A. Lighting**

All off-street parking space lighting shall meet the standards of Division 10.7, Outdoor Lighting.

##### **B. Landscaping**

Landscaping standards shall apply to all surface Off-Street Parking Areas according to Division 10.5, Landscaping, Fences, Walls and Screening.

### **SECTION 10.4.6 USE AND MAINTENANCE OF PARKING AREAS**

#### **10.4.6.1 General Use and Maintenance Standards**

Off-street parking space, including the spaces in which vehicles are parked as well as all drive aisles and access drives, shall be maintained and used in compliance with the following standards:

- A. Off-street parking space shall not be used for the sale, repair, dismantling or servicing of any vehicles, equipment, materials or supplies.
- B. No cleaning or maintenance of parking lots in a Residential Zone District utilizing motorized equipment may be performed between 11:00 p.m. and 6:30 a.m. each day.
- C. Except in the CMP-NWC-F and CMP-NWC-G zone districts, loudspeaker or other amplified systems shall not be used in Off-Street Parking Areas.

- D. For additional standards applicable to the parking of vehicles, see Division 10.9, Parking, Keeping and Storage of Vehicles.

#### 10.4.6.2 Fee for ~~Required~~ Parking Allowed

~~Required~~ parking may be available as free parking, contract parking, or on an hourly or daily fee basis.

#### 10.4.6.3 Flexibility in Use of Accessory Parking Areas

##### A. Intent

1. Provide flexibility in a property owner's use of accessory parking spaces when such spaces are not fully utilized by the owner for the subject primary use(s).
2. Allow for the limited sharing of otherwise unused or under-utilized accessory parking spaces to satisfy parking demand in areas near the subject Off-Street Parking Area where the supply of on-street or off-street parking may be insufficient to meet such demand.

##### B. Applicability

This Section 10.4.7.3 allowance shall apply only under the following conditions:

1. Shall be applied only to the use of existing Accessory Parking spaces, where the subject zone lot contains both a Primary Use and Accessory Parking serving that Primary Use.
2. Shall not apply to a zone lot containing a primary Surface Parking land use, regardless of the legal status of such Surface Parking use, and the BOA shall not have the authority to issue a variance to allow application of this Section 10.4.7.3 to such zone lots.
3. ~~This allowance shall not be used to meet the minimum parking requirements of any primary use. (For that scenario, see Section 10.4.5.4, Shared Vehicle Parking, or Section 10.4.4.5.B, Off-Site Vehicle Parking.)~~

##### C. Flexible Use of Accessory Parking Spaces Allowed ~~with Zoning Permit~~

1. ~~At any time when Accessory Parking spaces are not needed to meet the parking demand of the subject Primary Use (e.g., when the Primary Use is closed for business), the property owner may make available any unused or under-utilized Accessory Parking spaces to serve the parking needs of one or more Primary Uses not located on the same zone lot. A property owner may make unused or under-utilized accessory parking spaces on a Zone Lot available to serve the parking needs of one or more Primary Uses not located on the same Zone Lot.~~
2. ~~At all times, regardless of the option for flexible use allowed under this Section 10.4.7.3, the property owner shall maintain adequate Accessory Parking during all operating hours to serve the Primary Use(s) for which the Accessory Parking spaces are provided.~~
3. Such unused or under-utilized Accessory Parking spaces may be made available for a fee, at the property owner's option.
4. Such unused or under-utilized Accessory Parking spaces may be made available to serve a Primary Use located on a different zone lot whose parking is otherwise capped by a maximum parking standard.

## SECTION 10.4.7 LOADING

### 10.4.7.1 Intent

The intent of this Section's loading standards is to assure the provision of adequate off-street areas to allow vehicle to access, circulate, and service one or more Primary Uses on the zone lot.

### 10.4.7.2 Applicability

This Section 10.4.8, Loading, shall apply as follows:

- A. Loading spaces according to this Section shall be required when a primary use is established in all zone districts, except for the following:
  - 1. Establishment of a primary use in the SU, TU, TH, RH, MHC, MU, or RO zone districts.
  - 2. Establishment of an Event Space with Alternate Parking and Loading primary use on any portion of a zone lot within the CMP-NWC-G or CMP-NWC-F zone districts.
  - 3. An expansion of an existing Primary Use, or a Change of Use, when the expansion or Change of Use results in an increase in the use's Gross Floor Area or the number of units by 25 percent or less.
- B. The duty to provide and maintain off-street loading spaces shall be the joint and several responsibility of the operator and owner of the structure for which off-street loading spaces are required to be provided.
- C. No new structure shall be designed, erected, altered, used or occupied unless the off-street loading space required is provided, and the number of off-street loading spaces for structures actually used, occupied and operated on or after June 25, 2010, shall not be reduced below the minimum number of spaces required by this Division.

### 10.4.7.3 Standards

#### A. Required Number of Spaces

At least the following number of loading spaces, shall be provided:

PRIMARY USES	SQUARE FEET OF GROSS FLOOR AREA *	REQUIRED NUMBER OF SPACES
Retail Sales and Wholesale Trade or Storage Primary Uses	Less than or equal to 15,000	None
	Greater than 15,000 and less than or equal to 50,000	1
	Greater than 50,000 and less than or equal to 200,000	2
	Greater than 200,000 and less than or equal to 350,000	3
	Greater than 350,000	4
All Other Primary Uses	Less than or equal to 25,000	None
	Greater than 25,000 and less than or equal to 250,000	1
	Greater than 250,000 and less than or equal to 500,000	2
	Greater than 500,001 and less than or equal to 750,000	3
	Greater than 750,000	4

\* "Gross Floor Area" for purposes of calculating required loading spaces shall be determined as stated in Section 10.4.4, Minimum and Maximum Vehicle Parking.

#### B. Dimensions

At least the following dimensions shall be provided, plus an area or means adequate for maneuvering, ingress and egress entirely within zone lot boundaries. Backing to or from a public right-of-way for loading maneuvering is prohibited unless the Department of Transportation and Infrastructure ("DOTI") expressly approves such movements in unusual situations where the site is constrained and as part of an approved Site Development Plan.

- 1. For Wholesale Trade or Storage Primary Uses, each loading space shall be at least 35 feet long, 10 feet wide and 14 feet in vertical clear height.
- 2. For all other Primary Uses, each loading space shall be a minimum of 26 feet long, 10 feet wide, and 14 feet in vertical clear height.

### C. Shared Loading

The Zoning Administrator may approve shared loading to meet the minimum loading requirements for adjacent Primary Uses on the same Zone Lot or adjacent Zone Lots. The number of required loading spaces shall be calculated by adding the cumulative Gross Floor Area of all uses on all Zone Lots with access to the shared loading area.

### D. Location

#### 1. On-Site

Off-street loading spaces shall be located on the same zone lot as the structure for which provided, except as allowed in Section 10.4.8.3.C, Shared Loading, and subsection 10.4.8.3.D.2.

#### 2. On-Street

##### a. Applicability

On-street loading shall only be allowed where at least two or more loading spaces are required and where the Zoning Administrator has determined that the subject property is unusually small or irregularly shaped so that the reasonable development of the zone lot with the required loading spaces is difficult to achieve.

##### b. Standards

- i. No more than two required loading spaces may be located on the public right-of-way;
- ii. The spaces shall not create any adverse impacts on traffic or pedestrian movement;
- iii. DOTI must approve the loading space(s); and
- iv. At least one of the following shall be provided on the subject property zone lot:
  - a) One loading space that is 10 feet wide and 26 feet long; or
  - b) Two loading spaces that are each 10 feet wide and 20 feet long.

#### 10.4.7.4 Maintenance

All off-street loading space shall be maintained in compliance with the regulations for the maintenance of off-street parking space according to Section 10.4.7, Use and Maintenance of Parking Areas.

## SECTION 10.4.8 ~~PARKING CATEGORIES~~

### 10.4.8.1 ~~Vehicle Parking Categories~~

#### A. ~~Purpose~~

~~Parking categories are used to determine the minimum amount of parking spaces required for a specific primary use.~~

#### B. ~~Unclassified Uses~~

~~If for any reason the parking category of any primary use cannot be determined for the purpose of establishing the number of required vehicle parking spaces, the parking category of such use shall be determined by the Zoning Administrator according to Section 12.4.6, Code Interpretations and Determination of Unlisted Uses.~~

#### C. ~~Parking Category Table~~

~~The following parking categories apply to all primary uses permitted by this Code.~~

USE CATEGORY	SPECIFIC PRIMARY USE	PARKING CATEGORY
<b>Residential</b>		
Household Living	Dwelling, Single Unit	No Requirement
	Dwelling, Two Unit (includes provision of two units on one zone lot in a tandem house form)	Multi-Unit
	Dwelling, Multi-Unit	Multi-Unit
	Dwelling, Mixed Use	Multi-Unit
	Dwelling, Live / Work	Multi-Unit
	Manufactured Home Community	No Requirement
Residential Care	Residential Care, Type 1	Residential Low
	Residential Care, Type 2	Residential Low
	Residential Care, Type 3	Residential Low
	Residential Care, Type 4	Residential Low
Congregate Living	All Types	Residential Medium
<b>Civic, Public and Institutional</b>		
Basic Utilities	Utility, Major Impact	Commercial Low
	Utility, Minor Impact*	Commercial Low
Community/Public Services	Community Recreational Facility	Public Use Medium
	Day Care Center	Public Use Medium
	Postal Facility	Commercial Medium
	Public Safety Facility	Public Use Medium
	Hospital	Public Use High
	Correctional Institution	Public Use Medium
Cultural/Special Purpose/Public Parks & Open Space	Cemetery	No Requirement
	Library	Public Use Medium
	Museum	Public Use Medium
	Performing Arts Center	Public Use Medium
	City Park	No Requirement
	Open Space – Recreation	Public Use Low
	Open Space – Conservation	No Requirement
Education	Elementary School	Public Use Medium
	Secondary School	Public Use High
	University or College	Public Use Medium
	Vocational or Professional School	Public Use Medium
Public and Religious Assembly	All Types	Public Use Medium
<b>Commercial Sales, Services and Repair</b>		
Adult Business	All Types	Commercial Medium
Arts, Entertainment & Recreation	Recreation and Entertainment Services, Indoor	Commercial Medium
	Recreation and Entertainment Services, Outdoor	Commercial Medium
	Sports and/or Entertainment Arena or Stadium	Public Use Medium
	Theater and/or Performance Space	Public Use Medium
Parking of Vehicles	Parking, Garage	No Requirement
	Parking, Surface	No Requirement
Eating & Drinking Establishments	All Types	Commercial High
Lodging Accommodations	Bed and Breakfast Lodging	Commercial Medium
	Lodging Accommodations, All Others	Commercial Medium

USE CATEGORY	SPECIFIC PRIMARY USE	PARKING CATEGORY
Office	Dental / Medical Office or Clinic	Commercial Medium
	Office, All Others	Commercial Medium
Retail Sales, Service & Repair (Not Including Vehicle or Equipment Sales, Service & Repair)	Animal Services and Sales, Household Pets Only	Commercial Medium
	Animal Services and Sales, All Others	Commercial Medium
	Body Art Establishment	Commercial Medium
	Food Sales or Market	Commercial Medium
	Pawn Shop	Commercial Medium
	Pay Day Lending Services	Commercial Medium
	Retail Sales, Service & Repair -- Outdoor	Commercial Medium
	Retail Sales, Service & Repair, Special: Includes Gun Sales	Commercial Medium
	Retail Sales, Service & Repair, All Others	Commercial Medium
	Vehicle / Equipment Sales, Rentals, Service & Repair	Automobile Emissions Inspection
Automobile Gas / Service Station		Commercial Low
Automobile Wash, Laundry, Detail or Polishing Shop		Commercial Low
Automobile Repair Garage		Commercial Low
Automobile / Motorcycle / Light Truck Sales, Rentals, Leasing		Commercial Low
Automobile Pawn Lot or Vehicle Auctioneer		Commercial Low
Heavy Vehicle / Equipment Sales, Rentals & Service		Commercial Low
<b>Industrial, Manufacturing and Wholesale</b>		
Communications and Information	Communication Services	Commercial Low
	Telecommunications Towers*	No Requirement
	Telecommunication Facilities -- All Others	No Requirement
Industrial Services	Contractors, Special Trade -- General	Commercial Low
	Food Preparation and Sales, Commercial	Commercial Low
	Laboratory -- Research & Development, Technological Services	Commercial Low
	Service/Repair, Commercial	Commercial Low
Manufacturing and Production	Manufacturing, Fabrication & Assembly -- Custom	Commercial Low
	Manufacturing, Fabrication & Assembly -- General	Commercial Low
	Manufacturing, Fabrication & Assembly -- Heavy	Commercial Low
Mining & Extraction and Energy Producing Systems	Oil, Gas -- Production, Drilling*	Commercial Low
	Sand or Gravel Quarry	Commercial Low
	Wind Energy Conversion Systems*	No Requirement
Transportation Facilities	Airport	No Requirement
	Helipad, Helistop, Heliport	No Requirement
	Railroad Facilities	Commercial Low
	Railway Right-of-Way	No Requirement
	Terminal, Station, or Service Facility for Passenger Transit System	Commercial Low
	Terminal, Freight, Air Courier Services	Commercial Low
Waste-Related Services	Automobile Parts Recycling Business	Commercial Low
	Junkyard	Commercial Low
	Recycling Center	Commercial Low
	Recycling Collection Station	Commercial Low
	Recycling Plant, Scrap Processor	Commercial Low
	Solid Waste Facility	Commercial Low

USE CATEGORY	SPECIFIC PRIMARY USE	PARKING CATEGORY
Wholesale, Storage, Warehouse & Distribution	Automobile Towing Service Storage Yard	Commercial Low
	Contractors, Special Trade - Heavy, Yard	Commercial Low
	Container Storage (Mini-Storage)	Commercial Low
	Heavy Equipment Sales or Rentals	Commercial Low
	Storage Services	Commercial Low
	Vehicle Storage, Commercial	Commercial Low
	Wholesale Trade, General, and/or Storage of Toxic and/or Hazardous Materials	Commercial Low
Wholesale Trade, Light, and/or Storage of Nontoxic and/or Nonhazardous Materials	Commercial Low	
<b>Agriculture</b>		
Agriculture	Aquaculture	Commercial Low
	Garden, Urban	Commercial Low
	Husbandry, Animal Husbandry, Plant	Commercial Low
	Plant Nursery	Commercial Low

### 10.4.8.2 Bicycle Parking Categories

Bicycle parking is required based on the specific primary uses's assigned parking category, according to Section 10.4.9.1, Vehicle Parking Categories. The bicycle parking standards are then varied by neighborhood context, as set forth in the tables below.

SUBURBAN NEIGHBORHOOD CONTEXT AND I-A, B-ZONE DISTRICTS		
Parking Category	Minimum Bicycle Parking Spaces Required	% Parking Spaces Provided in Enclosed Bicycle Parking Facility / Fixed Bicycle Rack Parking Facility
Multi-unit	1/5 units	80%/20%
Residential Low	No Requirement	n/a
Residential Medium	No Requirement	n/a
Commercial High	1/5,000 sq. ft. GFA	0%/100%
Commercial Medium	1/20,000 sq. ft. GFA	60%/40% Retail, sales, service and repair uses: 20%/80%
Commercial Low	No Requirement	n/a
Public Use High	1/20,000 sq. ft. GFA	0%/100%
Public Use Medium	1/10,000 sq. ft. GFA	0%/100%
Public Use Low	No Requirement	n/a

URBAN EDGE NEIGHBORHOOD CONTEXT		
Parking Category	Minimum Bicycle Parking Spaces Required	% Parking Spaces Provided in Enclosed Bicycle Parking Facility / Fixed Bicycle Rack Parking Facility
Multi-unit	1/5 units	80%/20%
Residential Low	No Requirement	n/a
Residential Medium	No Requirement	n/a
Commercial High	1/5,000 sq. ft. GFA	0%/100%
Commercial Medium	1/20,000 sq. ft. GFA	60%/40% Retail, sales, service and repair uses: 20%/80%
Commercial Low	No Requirement	n/a
Public Use High	1/20,000 sq. ft. GFA	0%/100%
Public Use Medium	1/10,000 sq. ft. GFA	0%/100%
Public Use Low	No Requirement	n/a



URBAN-NEIGHBORHOOD-CONTEXT-AND-MASTER-PLANNED-CONTEXT		
Parking-Category	Minimum-Bicycle-Parking-Spaces-Required	%-Parking-Spaces-Provided-in-Enclosed-Bicycle-Parking-Facility-/Fixed-Bicycle-Rack-Parking-Facility
Multi-unit	1/4 units	80%/20%
Residential-Low	No-Requirement	n/a
Residential-Medium	No-Requirement	n/a
Commercial-High	1/3,000 sq. ft. GFA	0%/100%
Commercial-Medium	1/10,000 sq. ft. GFA	60%/40% Retail, sales, service and repair uses: 20%/80%
Commercial-Low	No-Requirement	n/a
Public-Use-High	1/10,000 sq. ft. GFA	0%/100%
Public-Use-Medium	1/10,000 sq. ft. GFA	0%/100%
Public-Use-Low	No-Requirement	n/a

GENERAL-URBAN-NEIGHBORHOOD-CONTEXT-AND-ALL-I-MX-ZONE-DISTRICTS		
Parking-Category	Minimum-Bicycle-Parking-Spaces-Required	%-Parking-Spaces-Provided-in-Enclosed-Bicycle-Parking-Facility-/Fixed-Bicycle-Rack-Parking-Facility
Multi-unit	1/4 units	80%/20%
Residential-Low	No-Requirement	n/a
Residential-Medium	No-Requirement	n/a
Commercial-High	1/3,000 sq. ft. GFA	0%/100%
Commercial-Medium	1/10,000 sq. ft. GFA	60%/40% Retail, sales, service and repair uses: 20%/80%
Commercial-Low	No-Requirement	n/a
Public-Use-High	1/10,000 sq. ft. GFA	0%/100%
Public-Use-Medium	1/10,000 sq. ft. GFA	0%/100%
Public-Use-Low	No-Requirement	n/a

URBAN-CENTER-NEIGHBORHOOD-CONTEXT-AND-CAMPUS-ZONE-DISTRICTS		
Parking-Category	Minimum-Bicycle-Parking-Spaces-Required	%-Parking-Spaces-Provided-in-Enclosed-Bicycle-Parking-Facility-/Fixed-Bicycle-Rack-Parking-Facility
Multi-unit	1/2 units	80%/20%
Residential-Low	No-Requirement	n/a
Residential-Medium	No-Requirement	n/a
Commercial-High	1/1,500 sq. ft. GFA	0%/100%
Commercial-Medium	1/7,500 sq. ft. GFA	60%/40% Retail, sales, service and repair uses: 20%/80%
Commercial-Low	No-Requirement	n/a
Public-Use-High	1/5,000 sq. ft. GFA	0%/100%
Public-Use-Medium	1/10,000 sq. ft. GFA	0%/100%
Public-Use-Low	No-Requirement	n/a

DOWNTOWN-NEIGHBORHOOD-CONTEXT-D-LD, D-GT, D-AS, D-AS-12+, D-AS-20+ ZONE DISTRICTS ONLY		
Parking-Category	Minimum-Bicycle-Parking-Spaces-Required	%-Parking-Spaces-Provided-in-Enclosed-Bicycle-Parking-Facility-/Fixed-Bicycle-Rack-Parking-Facility
Multi-unit	1/2 units	80%/20%
Residential-Low	No-Requirement	n/a
Residential-Medium	No-Requirement	n/a
Commercial-High	1/1,000 sq. ft. GFA	0%/100%
Commercial-Medium	1/7,500 sq. ft. GFA	60%/40% Retail, sales, service and repair uses: 20%/80%

DOWNTOWN-NEIGHBORHOOD-CONTEXT-D-LD, D-GT, D-AS, D-AS-12+, D-AS-20+ ZONE-DISTRICTS-ONLY		
Parking-Category	Minimum-Bicycle-Parking-Spaces-Required	% Parking-Spaces-Provided-in-Enclosed-Bicycle-Parking-Facility/Fixed-Bicycle-Rack-Parking-Facility
Commercial Low	No Requirement	n/a
Public Use High	1/5,000 sq. ft. GFA	0%/100%
Public Use Medium	1/10,000 sq. ft. GFA	0%/100%
Public Use Low	No Requirement	n/a

DOWNTOWN-NEIGHBORHOOD-CONTEXT-D-CPV-T, D-CPV-R, D-CPV-C ZONE-DISTRICTS-ONLY		
Parking-Category	Minimum-Bicycle-Parking-Spaces-Required	% Parking-Spaces-Provided-in-Enclosed-Bicycle-Parking-Facility/Fixed-Bicycle-Rack-Parking-Facility
Multi-unit	1.1/unit	80%/20%
Residential Low	No Requirement	n/a
Residential Medium	No Requirement	n/a
Commercial High	1/1,000 sq. ft. GFA	0%/100%
Commercial Medium	1/4,000 sq. ft. GFA Lodging accommodations uses: 1/7,500 sq. ft. GFA	60%/40% Retail, sales, service and repair uses: 20%/80%
Commercial Low	No Requirement	n/a
Public Use High	1/5,000 sq. ft. GFA	0%/100%
Public Use Medium	1/5,000 sq. ft. GFA	0%/100%
Public Use Low	No Requirement	n/a

## SECTION 10.5.3 RESERVED

## SECTION 10.5.4 LANDSCAPING STANDARDS

### 10.5.4.1 Applicability and Exceptions

#### A. Applicability

1. This Section 10.5.4 shall apply to development in all zone districts, except residential development in all SU, TU, and MHC zone districts.
2. Whenever the area of an existing surface parking lot is expanded or when a new area is constructed, the entire Off-Street Parking Area shall be landscaped according to this Section 10.5.4.
3. For Surface Parking as a Primary Use in the D-LD, D-CV, D-C, D-TD, D-GT and D-AS zone districts, Section 8.10.2, Surface Parking Lot Landscaping, shall apply rather than this Section 10.5.4.
4. The City of Denver Landscaping of Parking Areas Rules and Regulations shall not apply to properties zoned under the Denver Zoning Code.
5. See the City of Denver Streetscape Design Manual for additional provisions.

#### B. Exceptions

##### 1. Process for Exception Requests

All requests for exceptions from the general site and surface parking landscaping requirements shall be reviewed according to Section 12.4.5, Administrative Adjustments.

##### 2. Exception for Physical Limitations

If the Zoning Administrator determines that, because of physical limitations imposed by the location and arrangement of existing buildings or by site dimensions, it is impossible or impractical to meet the requirements of this Section, the Zoning Administrator may:

- a. Allow part or all of the landscaped area required to be provided elsewhere on the zone lot; or
- b. Waive part or all of such requirements altogether, provided that the standards are implemented to the fullest extent possible, given the physical limitations.

##### 3. Exception for Excessive Improvement Costs

If the landscaping requirements of this Section are applicable because of either an addition to the gross floor area of an existing building or the change of use of an existing building, the Zoning Administrator may:

- a. Waive certain of landscape requirements on the basis that the cost of meeting such requirements exceeds 50 percent of the cost of either constructing the building addition or changing the use.
- b. This waiver may be granted only if the applicant provides the Zoning Administrator with an itemization of the landscape improvements and costs necessary to meet the requirements, together with an estimate prepared by a licensed contractor or other qualified professional, of the construction cost of the building addition or the construction and other tenant improvement costs related to the change of use.

##### 4. Exception for Preservation of Existing Trees

- a. Preservation of existing trees may count toward landscape requirements of the Code.
- b. If, in order to comply with ~~both (1)~~ these standards for the landscaping of Off-Street Parking Areas, ~~and (2) the off-street parking requirements~~, it would be necessary

to remove mature, existing trees, the Zoning Administrator may allow reasonable reductions in ~~either (1) the size of required landscaped areas (for the purpose of accommodating the required parking), or 2) the number of required parking spaces.~~

#### 10.5.4.2 Site Landscaping Standards - Group 1

##### A. Applicability

###### 1. Zone Districts

Section 10.5.4.1, Applicability and Exceptions shall apply, except this Section 10.5.4.2 shall not apply in the I-A and, I-B zone districts, and in the I-MX zone districts for development using the Industrial Primary Building Form.

###### 2. Build-To Range

All "open areas" within a required build-to range along the entire applicable street frontage shall be landscaped (e.g., the area located within the 0 to 15 feet build-to range along the primary street).

###### 3. Required Setbacks

All "open areas" within a required minimum setback shall be landscaped.

###### 4. Open Area Defined

For purposes of this Section 10.5.4.2, "open area" shall mean areas not occupied by either:

- a. Building(s);
- b. An allowed encroachment into a build-to or setback;
- c. A required entrance and/or pedestrian connection;
- d. On-site pedestrian walkways no wider than 5 feet;
- e. Surface Off-Street Parking Areas;
- f. Area dedicated to permanent outdoor amenities related to the primary use, such as an outdoor eating and serving area; or
- g. Areas that other City laws require to be kept free of live planting material.

##### B. Minimum Landscaping Standards

1. A minimum of 50% of the applicable area shall be landscaped with live planting material and the remaining 50% shall be landscaped with either live or non-live landscaping material, according to Section 10.5.4.6 Landscaping Material Standards. (See Figures 10.5-1 and 10.5-2)
2. Trees and shrubs in the Campus National Western Center-Core (CMP-NWC-C), Urban Center ("C-") and Downtown ("D-") zone districts may be located in planters.
3. Existing trees and shrubs located in the required landscape areas shall be credited towards this requirement, provided they meet Section 10.5.4.6, Landscaping Material Standards.

MAXIMUM HEIGHT WITH INCENTIVES IN STORIES AND FEET		
ZONE DISTRICT	GENERAL BUILDING FORM	SHOPFRONT BUILDING FORM
3-story zone districts	4/55'	4/55'
5-story zone districts	7/95'	7/95'
8-story zone districts	12/150'	12/150'
12-story zone districts	16/200'	16/200'
16-story zone districts	22/275'	22/275'
20-story zone districts	30/375'	30/375'

2. Maximum height with incentives may be limited if the Primary Structure is located near a Protected District per the rules set forth in the applicable building form standards and in Section 13.1.3.4 Height in Feet.

## SECTION 10.12.2 FLOOR AREA PREMIUMS OR INCENTIVES

### 10.12.2.1 Intent

To encourage additional affordable housing beyond mandatory requirements by providing flexibility in building floor area where applicable in Downtown Neighborhood Context (D-) zone districts.

### 10.12.2.2 Applicability

This Section 10.12.2 shall apply to the Downtown Core and Downtown Theater District (D-C/D-TD), Downtown Golden Triangle (D-GT), and Downtown Arapahoe Square (D-AS) zone districts.

### 10.12.2.3 Standards

Refer to Article 8 for specific floor area premium or incentive applicability and standards.

## SECTION 10.12.3 ~~PARKING INCENTIVES~~

### 10.12.3.1 ~~Intent~~

~~To encourage on-site affordable housing and mixed income development by reducing or eliminating vehicle parking requirements.~~

### 10.12.3.2 ~~Standards~~

~~Refer to Section 10.4.5.1, Vehicle Parking Exemptions, and Section 10.4.5.2, Alternative Minimum Vehicle Parking Ratios, for specific applicability and standards.~~

## DIVISION 11.1 GENERAL PROVISIONS

### SECTION 11.1.1 INTENT

- 11.1.1.1 Article 11 sets forth the limitations specific to primary, accessory and temporary uses permitted under this Code. Limitations in this Article 11 are generally intended to:
- A. Promote continued economic development while mitigating the potential for adverse impacts on surrounding properties, surrounding residential uses and neighborhoods, and the physical environment;
  - B. Implement Comprehensive Plan and Blueprint Denver objectives to promote walkable, pedestrian environments in appropriate neighborhood contexts and zone districts;
  - C. Encourage and facilitate the reuse of existing structures;
  - D. Accommodate the special housing needs of segments of the resident population, while balancing those needs with a neighborhood's interest in notification and public input; and
  - E. Encourage and facilitate implementation of sustainable activities or uses that promote long-term energy efficiency and reduce vehicle trips, such as urban agriculture, wind and solar energy facilities, and live-work and Home Occupation opportunities.
- 11.1.1.2 The hierarchy and structure of the use classifications, categories, and definitions in this Article 11 are intended to aid the City and code users in the interpretation of this Code over time.

### SECTION 11.1.2 APPLICABILITY

All primary, accessory, and temporary uses subject to this Article's limitations shall be established, operated, and maintained only in compliance with such limitations.

### SECTION 11.1.3 ORGANIZATION

Article 11 is organized into divisions and sections that track the organization of the Use ~~and Parking~~ Tables found in Articles 3 through 9, as follows:

- 11.1.3.1 Divisions** in Article 11 correspond to the same order of the use classifications (e.g., residential primary uses) found in the Use ~~and Parking~~ Tables.
- 11.1.3.2 Sections** in Article 11 correspond to the specific use types (e.g., multi-unit dwelling) found within each use classification (e.g., residential primary uses), organized within the sections first by use category (e.g., household living uses) and then by listing in alphabetical order.

### SECTION 11.1.4 ENCLOSURE OF USES

- 11.1.4.1 All primary accessory and temporary uses must be established, operated and maintained within a Completely Enclosed Structure, unless otherwise specifically allowed by this Code. The Use ~~and Parking~~ Tables in Articles 3-9 indicate when a use may be established, operated or maintained outside a Completely Enclosed Structure by including an asterisk "\*" next to the specific use type. For example, the asterisk following the "Telecommunication Tower\*" use type in the tables indicates that a telecommunication tower land use need not be enclosed.

## DIVISION 11.2 RESIDENTIAL PRIMARY USE LIMITATIONS

The Use ~~and Parking~~ Tables in Articles 3 through 9 reference limitations applicable to permitted primary, accessory, or temporary uses. This Division contains limitations applicable to primary residential uses permitted across multiple zone districts and neighborhood contexts.

### HOUSEHOLD LIVING USE CATEGORY

#### SECTION 11.2.1 DWELLING, SINGLE UNIT

##### 11.2.1.1 I-A, I-B Zone Districts

In the I-A, I-B zone districts, where permitted with limitations, single unit dwellings uses are permitted subject to compliance with the following limitations:

- A. There is an existing structure that was erected for single unit dwelling use prior to July 1, 2004, has not had its nonconforming use terminated, and is not a neglected or derelict building under the provisions of Article IX (neglected and derelict buildings), Chapter 10 (buildings and building regulations) of the Denver Revised Municipal Code.
- B. Future rebuilds, physical modifications, alterations, and/or additions to the structure containing the single unit dwelling shall comply with the provisions of the Denver Zoning Code as it applies to the urban house form in the U-SU-C zone districts.
- C. Accessory uses, accessory structures, home occupations, parking of vehicles and permitted signs shall be regulated by the Denver Zoning Code as it applies to a single unit dwelling use in the U-SU-C zone districts.
- D. The external effects of such uses shall be regulated by Division 10.11, Limitations on External Effects of Uses and shall not be exempt from these provisions due to the industrial zoning.
- E. The zone lot containing a single unit dwelling use shall be used and operated in its entirety as a residential use. Such zone lots shall not be amended.

#### SECTION 11.2.2 DWELLING, TWO UNIT

##### 11.2.2.1 All SU Zone Districts

In all SU zone districts, where permitted with limitations:

- A. Two Unit Dwelling uses that were legally established and Continuously Maintained on a zone lot shall be considered conforming uses in these districts.
- B. A structure containing such a Two Unit Dwelling use may be modified or demolished and rebuilt in conformity with the building form standards allowed in the subject SU zone districts and all applicable overlay districts without regard to the building form's use restrictions, or alternately in conformity with the duplex building form standards applicable in the U-TU-C zone districts and all applicable overlay districts, provided:
  1. The number of dwelling units on the zone lot shall not be increased above the number of dwelling units that existed when the use was legally established.
- C. Zone Lots containing Two-Unit Dwelling uses that were legally established and Continuously Maintained shall not be reduced, expanded or enlarged.
- D. Variances may be granted according to Section 12.4.7, Variance.

## DIVISION 11.3 CIVIC, PUBLIC AND INSTITUTIONAL PRIMARY USE LIMITATIONS

The Use ~~and Parking~~ Tables in Articles 3 through 9 reference any limitations applicable to permitted primary, accessory, or temporary uses. This Division contains limitations applicable to specific uses within the primary Civic, Public and Institutional Primary Use Classification across multiple zone districts and neighborhood contexts.

### BASIC UTILITIES USE CATEGORY

#### SECTION 11.3.1 UTILITY, MAJOR IMPACT

##### 11.3.1.1 All Residential Zone Districts; All Mixed Use Commercial Zone Districts

In all Residential Zone Districts and in all Mixed Use Commercial Zone Districts, except the Downtown zone districts and the CMP-NWC, CMP-NWC-C, CMP-NWC-G, CMP-NWC-F and CMP-NWC-R zone districts, where permitted with limitations, Major Impact Utility uses are limited to water reservoir, which need not be enclosed.

##### 11.3.1.2 All Open Space Context Zone Districts and O-1 Zone District

In all Open Space Context zone districts and the O-1 zone district, where permitted with limitations, Major Impact Utility uses are limited to water reservoir or, in the OS-B and O-1 zone district only, water filtration plant is also permitted.

##### 11.3.1.3 I-A, I-B Zone Districts; All Downtown Neighborhood Context Zone Districts; CMP-NWC, CMP-NWC-C, CMP-NWC-G, CMP-NWC-F, CMP-NWC-R Zone Districts

In the I-A, I-B zone districts, all Downtown Neighborhood Context zone districts, and the CMP-NWC, CMP-NWC-C, CMP-NWC-G, CMP-NWC-F and CMP-NWC-R zone districts where permitted with limitations:

###### A. Sanitary Service

All sanitary service utilities shall be located a minimum 500 feet from any Residential Zone District.

###### B. Solid Waste Facility

All solid waste facilities must be located in a Completely Enclosed Structure and must be located a minimum of 500 feet from any Residential Zone District.

###### C. Above-Ground Power, Gas, and Other Facilities

The expansion of transmission line capacity shall not require a zoning permit provided such expansion may be accomplished within an existing right-of-way or with existing structures or poles.

##### 11.3.1.4 I-A, I-B Zone Districts; CMP-NWC, CMP-NWC-C, CMP-NWC-G, CMP-NWC-F, CMP-NWC-R Zone Districts

In the I-A, I-B, CMP-NWC, CMP-NWC-C, CMP-NWC-G, CMP-NWC-F and CMP-NWC-R zone districts, where permitted with limitations

###### A. Spacing Required

The following major impact utilities shall be located a minimum of 500 feet from any Residential Zone District:

1. Sewage disposal plant.
2. Incinerator, publicly operated.
3. Electric generation plant, excluding nuclear powered plants.



2. If in a Residential Zone District or on a Zone Lot that abuts a Residential Zone District, the unenclosed Community Center use shall:
  - a. Have no outdoor public address system or any type of amplified music or sound device;
  - b. Comply with the outdoor lighting limitations in Section 11.3.3.4; and
3. If in a Residential Zone District and the unenclosed Community Center includes active recreation or outdoor entertainment facilities, shall comply with the limitations in Section 11.3.3.3 below.

### 11.3.3.2 All SU and TU Zone Districts

In all SU and TU zone districts, where permitted with limitations, a Community Center use operating in a Completely Enclosed Structure shall be established and/or operated only inside an existing nonresidential structure originally designed for a nonresidential use and not for Residential Occupancy.

### 11.3.3.3 All Residential Zone Districts

In all Residential Zone Districts, where permitted with limitations, a Community Center use operating in a Completely Enclosed Structure may include accessory outdoor recreation or entertainment services facilities subject to compliance with the following conditions:

- A. Establishment of proposed facility, and any expansion of such facility, shall be reviewed according to Section 12.4.2, Zoning Permit Review with Informational Notice.
- B. The proposed facility shall be located on the same zone lot and operated by the same owner and/or operator of the Community Center, and the applicant must be either the owner of record or has the permission of the owner of record to operate the proposed outdoor recreational or entertainment services facility.
- C. The facility occupies no more than 10 percent of the zone lot on which it is located.
- D. ~~Adequate off-street parking is provided by the Community Center to support the needs of the outdoor recreational or entertainment services facility.~~
- E. No other such outdoor recreational or entertainment services facility on a different zone lot is located within 500 feet of the proposed use.
- F. The hours of operation shall be 8:00 a.m. to one-half hour after sunset.
- G. The facility shall be operated and controlled in such a manner to prevent unauthorized use of the facility outside of the permitted hours of operation.
- H. Signs visible from the public rights-of-way are limited to no more than 3 signs providing directional or cautionary information not exceeding 4 square feet per sign in area and not more than 6 feet in height above grade.

### 11.3.3.4 All Residential Zone Districts and on Zone Lots Abutting Residential Zone Districts

In all Residential Zone Districts, where a Community Center is permitted with limitations, and where the subject zone lot abuts a Residential Zone District, all outdoor lighting shall be extinguished when outdoor facilities are not in use, or by 10:00 p.m. on Sundays through Thursdays, and by 11 p.m. on Fridays and Saturdays, whichever is earlier.

## DIVISION 11.4 COMMERCIAL SALES, SERVICE AND REPAIR PRIMARY USE LIMITATIONS

The Use ~~and Parking~~ Tables in Articles 3 through 9 reference any limitations applicable to permitted primary, accessory, or temporary uses. This Division contains limitations applicable to specific uses within the Commercial Sales, Service, and Repair Primary Use Classification across multiple zone districts and neighborhood contexts.

### ARTS, ENTERTAINMENT AND RECREATION USE CATEGORY

#### SECTION 11.4.1 ARTS, ENTERTAINMENT AND RECREATION USES

##### 11.4.1.1 OS-B Zone District

In the OS-B zone district, where permitted with limitations, all permitted arts, entertainment and recreation uses shall comply with the following limitations:

- A. Permitted accessory uses and structures are limited to:
  1. Swimming pools and customary associated buildings;
  2. Tennis, basketball, or other similar playing court;
  3. Buildings or structures intended to house management or maintenance offices, or maintenance or other equipment and supplies related to permitted open space and recreational use;
  4. Playground or picnic shelters/areas; and
  5. Water features and Public Art.
- B. All outdoor lighting shall be extinguished when outdoor facilities are not in use or by 10 p.m. on Sundays through Thursdays or 11 p.m. on Fridays and Saturdays, whichever is earlier.
- C. No portion of any recreation facility that is not in a Completely Enclosed Structure (e.g., basketball or racquet sport courts) shall be located nearer than 50 feet from the boundary of a Single Unit (SU) or Two Unit (TU) zone district. All distance and spacing requirements shall be measured according to the rule of measurement found in Section 13.1.11.

##### 11.4.1.2 All M-IMX and M-GMX Zone Districts

In the M-IMX and M-GMX Zone Districts, Sports and/or Entertainment Arena or Stadium uses, where permitted with limitations, shall comply with the following limitations:

- A. All sports and/or entertainment arena or stadium uses shall be a minimum of 500 feet from a Residential Zone District. All distance and spacing requirements shall be measured according to the rule of measurement found in Section 13.1.11.

#### SECTION 11.4.2 ARTS, RECREATION AND ENTERTAINMENT SERVICES, INDOOR

##### 11.4.2.1 All MX-2x, -2A, -2; MS-2x, -2 Zone Districts

In all MX-2x, -2A, -2; MS-2x, -2 zone districts, where permitted with limitations, seating capacity in a permitted Arts, Entertainment and Recreation, Indoor, use shall be limited to no more than 100 persons.

## **SECTION 11.4.5 SPORTS AND/OR ENTERTAINMENT ARENA OR STADIUM**

### **11.4.5.1 I-MX, I-A, I-B, and All OS Zone Districts**

In the I-MX, I-A, I-B, and all OS zone districts, where permitted with limitations, sports and/or Entertainment Arena or Stadium uses shall comply with the following limitations:

- A. All sports and/or entertainment arena or stadium uses shall be a minimum of 500 feet from a Residential Zone District. All distance and spacing requirements shall be measured according to the rule of measurement found in Section 13.1.11.

## **NONRESIDENTIAL USES IN EXISTING BUSINESS STRUCTURES IN RESIDENTIAL ZONE DISTRICTS USE CATEGORY**

## **SECTION 11.4.6 NONRESIDENTIAL USES IN EXISTING BUSINESS STRUCTURES IN RESIDENTIAL ZONES**

### **11.4.6.1 Limited Nonresidential Uses Permitted**

In all Residential Zone Districts, where permitted with limitations:

- A. Primary nonresidential and accessory uses permitted in the MS-2x zone district in the same neighborhood context as the subject property (e.g., U-MS-2x) may be operated in an existing business structure. If there is no MS-2x zone district in the same neighborhood context, the primary and accessory uses established by the U-MS-2x zone district shall apply.
- B. Any use established according to this Section 11.4.6 shall comply with the Use Limitations and use review procedure applicable to such use indicated in the Use ~~and Parking~~ Table for the subject MS-2x zone district.
- C. More than one primary nonresidential use may be permitted in the same existing business structure. In addition to any permitted primary nonresidential uses, one or more primary residential uses may also be permitted in the same existing business structure. For example, in a two-story existing building structure meeting the requirements of this Section, one or more nonresidential primary uses may be permitted on the ground story and one or more residential primary uses may be permitted on the second story.

### **11.4.6.2 Existing Business Structures Only**

The primary nonresidential uses permitted under this Section shall be permitted only within an existing structure meeting all of the following conditions:

- A. The applicant is the owner of the subject structure.
- B. The subject structure was legally erected.
- C. The applicant proves by a preponderance of evidence that the subject structure is a “business structure.” For purposes of this Section, “business structure” shall mean the subject structure or a portion of the subject structure was originally designed and constructed for a primary business use and occupancy, and not for Residential Occupancy. For structures constructed for both business use and occupancy and for Residential Occupancy, only the portion of the structure originally designed and constructed for business use and occupancy shall be regulated by this provision. “Primary business use and occupancy” means any use permitted in the U-MS-2x zone district that falls within one of the following primary use classifications as defined in this Code:
  1. Commercial sales, service and repair primary use classification;

#### 11.4.8.3 D-GT Zone District

In the D-GT zone district, where permitted with limitations, Surface Parking lots constructed after July 1, 1994 shall be permitted according to Section 12.4.2, Zoning Permit Review with Informational Notice, and shall only be approved provided that the following limitations are met:

- A. Such parking lot shall serve a specific, identified business or residential facility that is a permitted use then permitted and operating in the D-GT district.
- B. Any parking lot that is not located on the same zone lot as the use it serves, ~~and that provides amounts of parking beyond those required to meet the minimum parking requirements for such use according to this Article 11 and Division 10.4, Parking and Loading:~~
  - 1. Shall have some portion of such parking lot located within 200 feet of the zone lot containing the use it serves; and
  - 2. Shall not offer parking to the public in return for a fee; and
  - 3. Shall include signage stating that parking is available only for the specific, identified business or residential facility that it serves and that public parking is not permitted.

#### 11.4.8.4 CMP-H and CMP-EI Zone Districts

In the CMP-H and CMP-EI zone districts, where permitted with limitations:

- A. Surface parking of vehicles is permitted only to serve a use permitted in the district.
- B. Commercial Surface Parking lots are prohibited.

### EATING AND DRINKING ESTABLISHMENTS USE CATEGORY

#### SECTION 11.4.9 EATING AND DRINKING ESTABLISHMENTS, ALL TYPES

##### 11.4.9.1 All MX-2x, -2A, -2; MS-2x, -2, -CMP-H2, CMP-EI2 Districts

In all MX-2x, -2A, -2; MS-2x, -2, CMP-H2, CMP-EI2 zone districts abutting a SU or TU zone district, where permitted with limitations:

- A. Lighted signage for an Eating and Drinking Establishment shall be turned off during non-operating hours.
- B. All outdoor lighting for an Eating and Drinking Establishment shall be provided with full cut-off fixtures.

##### 11.4.9.2 All MX-2x, MS-2x, CMP-H2, CMP-EI2 Zone Districts

In all MX-2x, MS-2x, CMP-H2, CMP-EI2 zone districts, where permitted with limitations, in addition to compliance with the use limitations in this Section 11.4.9, if the eating and drinking establishment is less than 100 feet from the boundary of any Protected District, all business activities open to the public shall cease by 10:00 p.m., except on Friday and Saturday nights when all business activities open to the public shall cease by 11:00 p.m.

### OFFICE USE CATEGORY

#### SECTION 11.4.10 DENTAL/MEDICAL OFFICE OR CLINIC

##### 11.4.10.1 G-RO Zone District

In the G-RO zone district, where permitted with limitations, Dental/Medical Office or Clinic use is permitted provided, however, that such use that expands to create a gross floor area exceeding 10,000 square feet shall be reviewed according to Section 12.4.2, Zoning Permit Review with Informational Notice. Any such use that contains a gross floor area in excess of 10,000 square feet

and which was legally established on or before September 16, 1994, shall be considered a legal, conforming use and does not need to comply with Section 12.4.2, Zoning Permit Review with Informational Notice. This limitation shall not apply to rehabilitation centers for People with Disabilities.

#### **11.4.10.2 All Zone Districts**

In all zone districts, where permitted with limitations:

- A. In all zone districts, except the RO, RX, MX-2x, MS-2x, and I-B zone districts, up to 20 patients or clients may stay overnight at any one time in a Dental/Medical Office or Clinic use.
- B. In the RO, RX, MX-2x, MS-2x and I-B zone districts, overnight patient or client stays are prohibited.

### **RETAIL SALES, SERVICE AND REPAIR USE CATEGORY**

#### **SECTION 11.4.11 RETAIL SALES, SERVICE AND REPAIR, ALL TYPES**

##### **11.4.11.1 All MX-2x, -2A, -2; MS-2x, -2 Zone Districts**

In all MX-2x, -2A, -2; and MS-2x, -2 zone districts, where permitted with limitations:

- A. Lighted signage shall be turned off during non-operating hours.
- B. All outdoor lighting shall be provided with full cut-off fixtures.
- C. Retail Marijuana Stores and Medical Marijuana Centers are prohibited in these zone districts.
- D. Zoning permit review is required according to Section 12.4.2, Zoning Permit Review with Informational Notice for Liquor Stores and Manufacturer Sales Rooms.

##### **11.4.11.2 I-B Industrial Zone District**

In the I-B Industrial zone district, where permitted with limitations

- A. Retail Sales are permitted only as a Primary Use (and not an Accessory Use) and only if the Retail Sales use complies with at least one of the following limitations:
  - 1. The commodity sold in the Retail Sales use is grown, manufactured, processed, or fabricated on the same Zone Lot; or
  - 2. Where the commodity sold in the Retail Sales is not grown, manufactured, processed, or fabricated on the site, the Retail Sales use
    - a. Operates in addition to at least one other permitted Primary Use that is not a Retail Sales use and is located on the same Zone Lot as the Retail Sales use;
    - b. Is operated and maintained under the same ownership as at least one other permitted Primary Use located on the same Zone Lot; and
    - c. Is limited to a maximum of 20 percent of the gross floor area ("GFA") of total GFA of all other Primary Uses located on the same Zone Lot; or
  - 3. The Retail Sales use or uses is a minimum of 20,000 square feet GFA in any single primary structure on a zone lot, ~~and complies with the following limitations: Additionally, T~~the primary structure(s) containing the proposed Retail Sales use shall be located a minimum of 500 feet from any Residential Zone District, and vehicle traffic generated by the proposed Retail Sales use shall not create adverse impacts on nearby residential access streets.
    - a. ~~The Retail Sales use shall comply with the following parking standard instead of the minimum parking required in the Use and Parking Table in Article 9:~~
    - i. ~~The use shall provide a minimum of 1 parking space for each 600 square feet of Gross Floor Area.~~

- ii. ~~The Zoning Administrator may reduce the required parking to 1 space per 1,200 square feet upon finding that characteristics of the proposed Retail Sales use justify a reduction in the parking requirement.~~
- B. Retail Repair Services are limited to the following:
- 1. Repair of any commodity manufactured, processed, fabricated, stored or sold in the I-B zone district;
  - 2. Vehicle body shop;
  - 3. Upholstery or top shop;
  - 4. Paint shop;
  - 5. Refrigeration and air conditioning service and repair; or
  - 6. Disinfecting and pest control service.

## **SECTION 11.4.12 ANIMAL SERVICES AND SALES, HOUSEHOLD PETS ONLY**

### **11.4.12.1 All Zone Districts**

In all zone districts, where permitted with limitations:

- A. All sales and services shall be for household pets only. Wild or dangerous animal services and sales are prohibited.
- B. Overnight boarding is permitted within a completely enclosed building; however, animal services or sales uses over 20,000 square feet in gross floor area that use a majority of their gross floor area for retail sales, shall have no more than 15 percent of their gross floor area devoted to overnight boarding.
- C. The use must be completely enclosed except that outdoor animal runs or other areas in which dogs will be allowed outside of an enclosed structure off leash (hereinafter “outdoor run”) are permitted subject to compliance with the following conditions:
  - 1. Outdoor runs, including the addition, expansion, or relocation of an existing outdoor run, shall be reviewed according to Section 12.4.2, Zoning Permit Review with Informational Notice.
  - 2. Outdoor runs shall not be permitted within 20 feet of a habitable residential structure on a zone lot in a SU, TU, TH, or RH zone district.
  - 3. The outdoor run may operate only between the hours of 6:30 a.m. and 9:00 p.m.
  - 4. No more than 25 non-neutered or non-spayed dogs over the age of 6 months may be kept on the premises at any time.
- D. The facilities shall be constructed, maintained and operated so that neither the sound nor smell of any animals boarded or kept on the premises during the time that full enclosure is required can be discerned on other zone lots provided, however, that existing facilities may continue to be maintained and operated as previously permitted.

## **SECTION 11.4.13 ANIMAL SERVICES AND SALES, ALL OTHERS**

### **11.4.13.1 I-MX, I-A, I-B, M-IMX and M-GMX Zone Districts**

In the I-MX, I-A, I-B, M-IMX, and M-GMX zone districts, where permitted with limitations:

- A. Wild or dangerous animal boarding and breeding services are prohibited.

## SECTION 11.4.19 AUTOMOBILE SERVICES, LIGHT

### 11.4.19.1 All Zone Districts

In all zone districts, where permitted with limitations:

#### A. Limitation on Automobile Fueling Stations

##### 1. Intent

The limitations on Automobile Services, Light are intended to promote pedestrian activity and neighborhood-serving commercial by avoiding clustering of automobile fueling stations unless they are combined with commercial space that provides opportunities for the sale of groceries, home goods or other products that could serve nearby residents.

##### 2. Limitations

In all Zone Districts, an Automobile Services, Light, use containing an Automobile Fueling Station must comply with the following limitations:

- a. The use shall not be located within 300 feet of a Protected District, unless the proposed use is included in the same approved Site Development Plan with at least one Food Sales or Market or Retail Sales, Service and Repair, All Others use with a gross floor area of 20,000 square feet or greater.
- b. The use shall not be located within 1/4 mile of any other Automobile Fueling Station, unless the proposed use is included in the same approved Site Development Plan with at least one Food Sales or Market or Retail Sales, Service and Repair, All Others use with a gross floor area of 20,000 square feet or greater. For the purpose of administering this use limitation, "any other Automobile Fueling Station" shall mean any Zone Lot containing an Automobile Fueling Station with a valid zoning permit, or any Zone Lot with an approved and unexpired Site Development Plan that includes an Automobile Fueling Station.
- c. The use shall not be located within 1/4 mile of a Rail Transit Station Platform.

#### B. Automobile wash, laundry, detail or polishing shops are permitted as a type of Automobile Service, Light, use, subject to compliance with the following standards:

1. An automobile wash, laundry, detail or polishing shop shall be sited on a zone lot and constructed, operated, and maintained in compliance with the building form standards stated in the applicable zone district.
2. The structure housing the primary use shall be setback a minimum 8 feet from any abutting Residential Zone District.
3. Adequate landscaping and solid fencing shall be installed to control the effects of noise where such bay is located adjacent to a residential use or a Residential Zone District.
4. If the zone lot containing the use abuts a SU or TU zone district, the hours of operation shall be limited to the time period between 7:00 a.m. and 10:00 p.m.
5. The use shall provide, ~~in addition to any other required off-street parking,~~ sufficient hard-surfaced and dust-free space on the same zone lot to accommodate at least 3 vehicles waiting to be washed for each washing stall.

## **SECTION 11.4.20 AUTOMOBILE SERVICES, HEAVY**

### **11.4.20.1 All Zone Districts**

In all zone districts, where permitted with limitations, review is required according to Section 12.4.9, Zoning Permit with Special Exception Review, for facilities that involve an environmental hazard as determined by the Denver Fire Code, including but not limited to the following:

- A. Vehicle body shop,
- B. Upholstery or top shop, and
- C. Paint shop.

### **11.4.20.2 All CC, MS; I-MX, I-A; M-IMX Zone Districts**

In all CC, MS; I-MX, I-A; and M-IMX zone districts, where permitted with limitations:

- A. The zone lot for all automobile services, heavy, uses shall be enclosed with a solid fence or wall except for the following excluded areas:
  - 1. The Primary Street frontage of the zone lot directly in front of the Primary Street facing building wall or a Primary Street facing entrance of the primary structure, and in no case shall such fence or wall be required along more than 40 percent of the length of the Primary Street frontage of the zone lot described in this Section 11.4.20.2;
  - 2. The Primary Street frontage of the zone lot directly in front of an automobile retail display area; or
  - 3. Any portion of a zone lot line containing a building wall.
- B. Such fence or wall shall be constructed to a height adequate to conceal any vehicles, equipment, or parts located on the zone lot; provided, the height and location of such wall or fence shall not interfere with clear sight at the intersection with a right-of-way and complies with the Denver Building and Fire Code.
- C. Permitted fence or wall materials shall consist of wood, brick, masonry or other similar durable materials as approved by the Zoning Administrator
- D. Prohibited fence or wall materials include salvaged doors and corrugated or sheet metal.

## **SECTION 11.4.21 AUTOMOBILE / MOTORCYCLE, LIGHT TRUCK SALES, RENTAL AND/OR LEASING; PAWN LOT OR VEHICLE AUCTIONEER**

### **11.4.21.1 All Downtown Neighborhood Context Zone Districts and All C-CCN Zone Districts**

In all Downtown Neighborhood Context zone districts and in all C-CCN zone districts, where permitted with limitations:

- A. The use shall be operated in a Completely Enclosed Structure with no outdoor displays, sales, or storage.
- B. Automobile pawn lots are prohibited.

### **11.4.21.2 All RX and MS Zone Districts**

In all RX and MS zone districts, where permitted by limitations, all Automobile / Motorcycle, Light Truck Sales, Rental and/or Leasing uses and all Pawn Lot or Vehicle Auctioneer uses shall be operated in a Completely Enclosed Structure, with no outdoor displays, sales, or storage.

### **11.4.21.3 All Zone Districts**

In all zone districts, where permitted with limitations:



- A. Outdoor public address or loudspeaker systems are prohibited.
- B. Accessory uses and activities may include the retail sale of vehicle accessories, oil, grease, antifreeze, tires and batteries, and other similar products; and provision of services to the extent of installing the foregoing items, making minor mechanical adjustment, washing and polishing vehicles.
- C. The facility shall not include Heavy Automobile Service uses, either as an accessory or primary use, unless otherwise permitted as a primary use in the subject zone district.
- D. Adjoining Residential Zone Districts shall be protected from the external effects of permitted outdoor vehicle or equipment display or storage areas by the establishment of landscaped buffers or an opaque fence or wall at least 5 feet high, by the location of landscaped employee or public parking areas, or by other means to achieve the same protection purpose.
- E. Vehicles being displayed, serviced or stored shall not be parked on streets, alleys, public sidewalks or public park strips.
- F. As permitted, vehicles displayed outside a Completely Enclosed Structure may have individual signs and, when provided, such signs shall be located only inside such vehicles.
- G. For facilities engaged only in the rental of automobiles, the land area assigned for storage of rental automobiles shall not be included for computation of any **required maximum** off-street parking **spacestandard**.

## **SECTION 11.4.22 HEAVY VEHICLE / EQUIPMENT SALES, RENTALS, AND SERVICES**

### **11.4.22.1 All I-MX, I-A; M-IMX Zone Districts**

In all I-MX, I-A; and M-IMX, zone districts, where permitted with limitations:

- A. Heavy Vehicle / Equipment Sales, Rentals, and Services uses shall be located 500 feet or more from the nearest boundary of any Residential Zone District existing at the time of application for the use.

### **11.4.22.2 I-B Zone District**

In the I-B zone district, aircraft maintenance and repair shall be located 500 feet or more from the nearest boundary of a Residential Zone District existing at the time of application.

## DIVISION 11.5 INDUSTRIAL, MANUFACTURING AND WHOLESALE PRIMARY USE LIMITATIONS

The Use ~~and Parking~~ Tables in Articles 3 through 9 reference any limitations applicable to permitted primary, accessory, or temporary uses. This Division contains limitations applicable to specific uses within the Industrial, Manufacturing and Whole Primary Use Classification across multiple zone districts and neighborhood contexts.

### COMMUNICATIONS AND INFORMATION USE CATEGORY

#### SECTION 11.5.1 COMMUNICATION SERVICES

##### 11.5.1.1 All RX, CC, MX, MS Zone Districts

In all RX, CC, MX, MS zone districts, where permitted with limitations, where the permitted maximum building height in the zone district is 3 stories or less, a transmitter shall be reviewed according to Section 12.4.9, Zoning Permit with Special Exception Review.

##### 11.5.1.2 All Downtown Neighborhood Context Zone Districts

In all Downtown Neighborhood Context zone districts, where permitted with limitations, this use is limited to radio and television broadcasting, including transmitter.

#### SECTION 11.5.2 TELECOMMUNICATIONS TOWERS; TELECOMMUNICATIONS TOWER - ALTERNATIVE STRUCTURE; TELECOMMUNICATION FACILITIES - ALL OTHERS

##### 11.5.2.1 All Zone Districts

In all zone districts, where permitted with limitations:

###### A. Intent

The intent of this Section 11.5.2 is to establish regulations for telecommunications facilities to achieve the following goals:

1. To protect residential areas and lands by minimizing adverse impacts of towers;
2. To encourage the location of towers in nonresidential zone districts;
3. To minimize the total number of towers in the community;
4. To encourage the joint use of new and existing tower locations;
5. To ensure that towers are located in areas that minimize adverse impacts;
6. To ensure towers and antennas are configured in a way that minimizes adverse visual impacts by careful design, appropriate siting, landscape screening, and innovative camouflaging techniques;
7. To enhance the ability to provide telecommunications services to the community quickly, effectively and efficiently;
8. To consider public health and safety of telecommunications facilities;
9. To avoid damage to adjacent properties from tower failure through careful engineering and locating of tower structures;
10. To encourage the attachment of antennas to existing structures; and
11. To facilitate the provision of telecommunications services throughout the city.

## **DIVISION 11.6 AGRICULTURAL PRIMARY USE LIMITATIONS**

The Use ~~and Parking~~ Tables in Articles 3 through 9 reference any limitations and standards applicable to permitted primary, accessory, or temporary uses. This Division contains limitations and standards applicable to specific uses within the Agricultural Primary Use Classification across multiple zone districts and neighborhood contexts.

### **SECTION 11.6.1 AQUACULTURE**

In all zone districts, where permitted with limitations, the outdoor storage of waste material from fish processing is prohibited.

### **SECTION 11.6.2 GARDEN, URBAN**

#### **11.6.2.1 All Zone Districts**

In all zone districts, where permitted with limitations, bee keeping is permitted as accessory to the Urban Garden use, subject to compliance with the standards for accessory bee-keeping stated in Section 11.8.5, Keeping of Household Animals, except that the bee keeping use need not be sited within the rear 50% of the zone lot, and except that in an Industrial Context zone district, Open Space Context zone district, or the CMP-NWC, CMP-NWC-C, CMP-NWC-G, CMP-NWC-F and CMP-NWC-R zone districts, the number of permitted bee hives may be increased to a maximum of 2 hives per 6,000 square feet of gross zone lot area.

### **SECTION 11.6.3 HUSBANDRY, ANIMAL**

#### **11.6.3.1 I-MX, I-A, I-B Zone Districts**

In the I-MX, I-A, I-B zone districts, where permitted with limitations, a Husbandry, Animal use shall be located at least 500 feet from a Residential Zone District.

#### **11.6.3.2 OS-B Zone Districts**

In the OS-B zone district, where permitted with limitations, a Husbandry, Animal use is limited to the raising and/or grazing of livestock animals and any confinements for such animals, provided such use is located at least 500 feet from a Residential Zone District.

### **SECTION 11.6.4 HUSBANDRY, PLANT**

#### **11.6.4.1 All Zone Districts**

In all zone districts, where permitted with limitations, growing of marijuana is permitted only as a “husbandry, plant” use, and shall occur only within a Completely Enclosed Structure.

#### **11.6.4.2 I-A Zone District**

In the I-A zone district, where permitted with limitations, when not operated inside a Completely Enclosed Structure, the Plant Husbandry use shall be located at least 500 feet from a Residential Zone District.

## DIVISION 11.7 ACCESSORY USE LIMITATIONS

The Use ~~and Parking~~ Tables in Articles 3 through 9 reference any limitations applicable to permitted primary, accessory, or temporary uses. This Division contains general standards applicable to all accessory uses across multiple zone districts and neighborhood contexts.

### SECTION 11.7.1 GENERAL PROVISIONS APPLICABLE TO ALL ACCESSORY USES

#### 11.7.1.1 General Allowance for Accessory Uses

**A. Accessory Uses are Incidental, Subordinate, and Customary to the Primary Use**

Accessory uses shall be clearly incidental, subordinate, customary to, and commonly associated with operation of a primary use. Accessory uses may be incidental to a primary use permitted without limitations, or to a permitted primary use with limitations. The Use ~~and Parking~~ Tables in Articles 3 through 9 list specific accessory uses permitted in each zone district; applicable limitations may further restrict the type or operations of an accessory use.

**B. Clarification When Primary Use is Unenclosed**

For an unenclosed primary use, such as a recreational playing field, urban garden, or other similar open space, the primary use is the unenclosed use of the land. Any structures and uses common and customary to the unenclosed primary use (such as structures containing restrooms, equipment storage, concession stands, etc.) shall be deemed “accessory uses” and/or “accessory structures” and shall comply with the applicable accessory building form standards and accessory use limitations.

#### 11.7.1.2 Limitations Applicable to All Accessory Uses

**A. General Limitations**

All accessory uses, except Accessory Dwelling Unit uses and Short-term Rental accessory uses, shall comply with all of the following general limitations. Accessory Dwelling Units uses, where permitted, shall comply with the specific limitations stated in Section 11.8.2, Accessory Dwelling Units, instead of these general limitations in Section 11.7.1.2.A. Short-term Rental accessory uses, where permitted, shall comply with the specific limitations stated in 11.8.10, Short-term Rental, instead of these general limitations in Section 11.7.1.2.A.

**1. Incidental, Subordinate, and Customary to the Primary Use**

Such use shall be clearly incidental, subordinate, and customary to and commonly associated with the operation of the primary use.

**2. Exception to Area/Size Limits - Outdoor Accessory Uses**

Subject to the general requirements in this Section that they remain incidental and subordinate to their associated primary use, the following outdoor (unenclosed) accessory uses are allowed without limit on the area (size) of such accessory outdoor use:

- a. Drive-Thru Facility;
- b. Outdoor Gathering Area;
- c. Outdoor Entertainment Area; and
- d. Garden.

**3. Maintained Under Same Ownership - Exceptions**

Such accessory use shall be operated and maintained under the same ownership and on the same zone lot as the primary use; provided, however, that in all Mixed Use Commercial Zone Districts, lessees or concessionaires may operate the accessory use; and provided further that in nonresidential structures owned and operated by a Place for Religious Assembly use in a Residential Zone District, non-profit lessees or concessionaires may operate the accessory use.

## DIVISION 11.8 USES ACCESSORY TO PRIMARY RESIDENTIAL USES - LIMITATIONS

The Use ~~and Parking~~ Tables in Articles 3 through 9 reference any limitations applicable to permitted primary, accessory, or temporary uses. This Division contains limitations applicable to specific uses accessory to primary residential uses across multiple zone districts and neighborhood contexts. In addition to meeting the general conditions and standards applicable to all accessory uses in Division 11.7 above, the following specific accessory uses shall comply with this Division's use-specific standards.

### SECTION 11.8.1 [RESERVED]

### SECTION 11.8.2 ACCESSORY DWELLING UNIT ("ADUS")

#### 11.8.2.1 All Zone Districts

In all zone districts, where permitted with limitations:

##### A. General Requirements

1. One Accessory Dwelling Unit use is permitted as accessory to each Primary Dwelling Unit containing a primary Single Unit Dwelling, Two Unit Dwelling, or Multi-Unit Dwelling use on a Zone Lot according to the requirements in this Section 11.8.2.
2. Accessory Dwelling Unit uses that are accessory to Two Unit and Multi-Unit Dwelling Primary Uses shall be established in a detached accessory structure and are not allowed within a Primary Structure. The detached accessory structure containing the Accessory Dwelling Unit use must be accessory to a Two Unit or Multi-Unit Dwelling use in one or more of the following building forms:
  - a. Duplex;
  - b. Row House; or
  - c. Town House.
3. In case of conflict between the requirements for Accessory Dwelling Units stated in this Section 11.8.2.1 and the general conditions stated in Division 11.7, Accessory Use Limitations, the requirements in this subsection shall apply.

##### B. General Building Requirements

1. Mobile Homes, Recreational Vehicles, and Trailers shall not be used as Accessory Dwelling Units.
2. The Gross Floor Area (GFA) of an Accessory Dwelling Unit use shall not exceed the limits as stated in the following table, unless otherwise specifically permitted by this Code.

## DIVISION 11.9 HOME OCCUPATIONS ACCESSORY TO PRIMARY RESIDENTIAL USES - ALL ZONE DISTRICTS

### SECTION 11.9.1 INTENT

- 11.9.1.1 Home Occupations are a type of accessory use that accommodates limited business activities conducted incidental to a primary residential use. This Division's allowance for Home Occupations is intended to achieve multiple city goals and objectives, including reducing the number of home-to-work vehicle trips with related improvements in air quality; facilitating small business ventures that contribute to the city's overall economic health; and accommodating demand for certain business services convenient to where prospective clients or customers live. The standards and review procedures applicable to Home Occupations are generally intended to minimize the impact such uses may have on the character and enjoyment of the surrounding residential neighborhood, while furthering the goals and objectives stated herein.
- 11.9.1.2 The Use ~~and Parking~~ Tables in Articles 3 through 9 reference any limitations applicable to permitted primary, accessory, or temporary uses. This Division contains limitations applicable to Home Occupation uses accessory to primary residential uses across multiple zone districts and neighborhood contexts.

### SECTION 11.9.2 LIMITATIONS APPLICABLE TO ALL HOME OCCUPATIONS - ALL ZONE DISTRICTS

In addition to any use-specific limitations in this Division 11.9, all Home Occupations in all zone districts shall comply with the following general limitations. In case of any conflict between the general limitations in this Section and a more specific use limitation, the more specific use limitation shall apply to the Home Occupation.

#### 11.9.2.1 Residential Use

A Home Occupation legally operated in a dwelling unit according to this Section shall be considered, in combination with the primary dwelling unit use, a residential use for all purposes of this Code.

#### 11.9.2.2 Location

- A. All Home Occupations shall operate in a Completely Enclosed Structure, except that:
1. A child care home (small or large) may include outdoor play and/or seating areas.
  2. For Fresh Produce and Cottage Foods Sales, retail sales may operate unenclosed.
- B. Home Occupations may operate in the primary dwelling unit structure, or in a detached accessory structure, allowed under this Code.

#### 11.9.2.3 Personal to Applicant

- A. Only the person or persons maintaining the dwelling unit as their primary place of residence shall operate the Home Occupation. For purposes of this provision only, "person" shall not include any corporation, partnership, firm, association, joint venture, or other similar legal entity.
- B. A zoning permit for an approved Home Occupation shall automatically expire at such time as the applicant no longer resides at the subject property.

#### 11.9.2.4 External Evidence and Signage

- A. If operated inside the primary dwelling unit structure, the Home Occupation shall not have a separate external entrance serving the Home Occupation.

- B. The Home Occupation shall not display or create outside the building any external evidence of the operation of the Home Occupation, except for the following:
  - 1. A child care home (small or large) may include outdoor play and/or seating areas.
  - 2. For Fresh Produce and Cottage Foods Sales, retail sales may operate unenclosed and utilize temporary, portable furniture such as tables, chairs, and umbrellas during permitted operating hours only.
  - 3. One non-animated, non-illuminated flat wall or window sign having an area of not more than 1 square foot is permitted for each street frontage of the subject zone lot.

#### 11.9.2.5 Size

One or more Home Occupation(s), whether located within a primary dwelling unit or a detached accessory structure, shall not in the aggregate utilize more than 20 percent of the gross floor area of the dwelling unit primary use, but in no case shall exceed 300 square feet. However, this limitation shall not apply to Adult Care Home, Child Care Home, Small or Large, Craft Work, or Artist Studio, or to portions of a Home Occupation permitted to operate unenclosed.

#### 11.9.2.6 Other Limitations

- A. The Home Occupation shall not have any employees or regular assistants not residing in the primary or accessory dwelling unit located on the subject zone lot, unless specifically permitted or required by the terms of a state or city license necessary to operate the permitted Home Occupation.
- B. The use of hand tools is permitted without limitation.
- C. The use of mechanical equipment is limited to the use of electric motors for power, with a total limitation of not greater than 3 horsepower.
- D. Other than as part of a permitted Fresh Produce Cottage Foods Sales use or permitted Online Retail Sales use, no Home Occupation may include on-premise Retail or Wholesale Sales.

### SECTION 11.9.3 CHILD CARE HOME – LARGE

Large Child Care Home, where permitted with limitations, is permitted as a Home Occupation subject to compliance with the following limitations:

- 11.9.3.1 The applicant shall be the owner or the applicant has written permission of the owner of the subject property.
- 11.9.3.2 The proposed Large Child Care Home is the applicant's primary place of residence.
- 11.9.3.3 The Zoning Administrator may approve a proposed Large Child Care Home that will be located adjacent to a previously permitted and operating Large Child Care Home only upon finding the following:
  - A. The applicant has submitted and as a condition of approval shall implement and maintain an ongoing traffic management program that ensures that the operation of the proposed Large Child Care Home, taking into consideration the adjacent existing Large Child Care Home, will not create traffic or parking problems in the neighborhood as a result of either the additional traffic introduced or the drop-off and pick-up of children; and
  - B. ~~Off-street parking shall be provided for each member of the staff on duty unless it is clearly proven that such off-street parking provisions should be modified by the Zoning Administrator.~~
  - C. The Zoning Administrator may fix such reasonable terms and conditions to the granting of a zoning permit found necessary to mitigate adverse impacts on adjacent properties.

## DIVISION 11.10 USES ACCESSORY TO PRIMARY NONRESIDENTIAL USES - LIMITATIONS

The Use ~~and Parking~~ Tables in Articles 3 through 9 reference any limitations applicable to permitted primary, accessory, or temporary uses. This Division contains limitations applicable to specific uses accessory to primary nonresidential uses across multiple zone districts and neighborhood contexts. In addition to meeting the general conditions and standards applicable to all accessory uses in Division 11.7 above, the following specific accessory uses shall comply with this Division's general and specific standards.

### SECTION 11.10.1 UNLISTED ACCESSORY USES

#### 11.10.1.1 All Zone Districts

- A. The Zoning Administrator shall determine and impose limitations on accessory uses not otherwise listed as permitted in an applicable Use ~~and Parking~~ Table in Articles 3 through 9, or not otherwise covered by the standards in this Article 11.
- B. All such determinations shall be reviewed according to the procedures and review criteria stated Section 12.4.6, Code Interpretations and Determination of Unlisted Uses. In addition to the criteria stated in Section 12.4.6, the Zoning Administrator shall determine whether a proposed accessory use is common and customary to a specific use by right, and if the use or structure is incidental to the specific use by right.
- C. The Zoning Administrator may impose limitations on the proposed accessory use, which shall be uniform throughout the zone district, and taking into consideration the intensity of the accessory use, the numbers of accessory uses, the space required by the accessory use, and the effect on adjacent property.
- D. Matters that may be regulated according to this Section 11.10.1 shall include, but shall not be limited to the types and intensity of repairs accessory to a use by right.

### SECTION 11.10.2 AMUSEMENT DEVICES ACCESSORY TO EATING/DRINKING ESTABLISHMENTS, COLLEGE/UNIVERSITY AND THEATER USES

#### 11.10.2.1 All Zone Districts

In all zone districts, where permitted with limitations:

- A. Notwithstanding more restrictive provisions of this Code, any establishment holding a beer and wine license, a hotel and restaurant license, or a club or tavern license, as issued by the State Department of Revenue, may maintain as an accessory use a number of Amusement Devices as follows:
  1. 10 devices or that number which occupies no more than 10 percent of the gross floor area of the Eating and Drinking Establishment, whichever is more restrictive. This allowance excludes adult amusement or entertainment.
- B. No Amusement Device serving as an accessory use to a primary use located within 1,000 feet of a school meeting the compulsory education laws of the state shall be operated by children under the age of 18 years old during the following described periods: between 8:00 a.m. and 4:00 p.m., Monday through Friday, from September 1 to June 15, excluding holiday vacations observed by such schools.
- C. Amusement devices may be operated and maintained as a part of a primary Theater and/or Performance Space use under the following limitations:
  1. Shall be operated within the same structure and under the same management as the theater;



2. Shall occupy a floor area not exceeding ten percent of the lobby area or shall contain no more than ten Amusement Devices, whichever is more restrictive;
  3. Shall be used by theater customers who have purchased a ticket and shall not be made available to the general public; and
  4. Shall be operated in compliance with all other applicable ordinances of the city.
- D. Amusement devices may be maintained and operated as a part of a permitted College or University use, provided such devices are located in the student center, lounge or residential dormitories and do not occupy an area more than 10 percent of the ground level floor area of the structure.

### **SECTION 11.10.3 AUTOMOBILE RENTAL SERVICES ACCESSORY TO CERTAIN RETAIL USES**

#### **11.10.3.1 S-CC-3x, -5x; E-CC-3x Zone Districts**

In S-CC-3x, -5x; E-CC-3x zone districts, where permitted with limitations:

- A. The automobile rental services shall be accessory to a primary Retail Sales, Service, & Repair, All Other use containing 20,000 or more square feet of Gross Floor Area, or to a primary Automobile/Motorcycle/Light Truck Sales, Rentals, Leasing use;
- B. Storage of all rental automobiles shall be located on the same zone lot as the office for the automobile rental service;
- C. Not more than 15 rental automobiles shall be stored at any one location;
- D. Servicing and maintenance work on automobiles is permitted only as limited to Automobile Services, Light, uses permitted in the zone district;
- E. The land area assigned for storage of rental automobiles shall not be included for computation of any **required maximum** off-street parking **spacestandard**; and
- F. Truck rental is not permitted.

### **SECTION 11.10.4 BOOK OR GIFT STORE; MEDIA RECORDING AND PRODUCTION FACILITIES ACCESSORY TO LIBRARY, MUSEUM, ASSEMBLY, AND COLLEGE/UNIVERSITY USE**

#### **11.10.4.1 All Residential Zone Districts**

- A. In a Residential zone district, where permitted with limitations, the following are permitted as accessory to a primary public Library, Museum, Place of Religious Assembly, or University or College use:
  1. Book or gift store; and
  2. Media recording and production facilities.
- B. All such accessory uses shall not occupy more than 10 percent of the gross floor area occupied by the primary use or uses.

### **SECTION 11.10.5 CAR WASH BAY ACCESSORY TO AUTOMOBILE SERVICES OR HOTEL USES**

#### **11.10.5.1 All Zone Districts**

In all zone districts, where permitted with limitations:

- A. A car wash bay is permitted as accessory to an Automobile Services, Light or Heavy, use only. The car wash bay shall be limited in capacity to one vehicle and may be operated with either manual or automatic equipment;
- B. An accessory car wash bay shall be sited on a zone lot and constructed, operated, and maintained in compliance with the standards stated in this subsection, and shall comply with the building form standards in the applicable zone district;
- C. The car wash bay shall be set back a minimum 8 feet from any abutting residential use or Residential Zone District;
- D. Adequate landscaping and solid fencing shall be installed to control the effects of noise where such bay is located adjacent to a residential use or a Residential Zone District;
- E. If the zone lot containing the car wash bay abuts a residential use or Residential Zone District, the hours of operation of the car wash bay shall be limited to the time period between 7:00 a.m. and 10:00 p.m.; and
- F. Sufficient space on the same zone lot shall be provided to accommodate 3 vehicles waiting for the car wash bay, ~~in addition to the required off-street parking for the primary use.~~

#### 11.10.5.2 CMP-NWC-F Zone District

In the CMP-NWC-F zone district, where permitted with limitations, a Car Wash Bay Accessory to Automobile Services or Hotel must be located a minimum of 50 feet from a South Platte River Primary Street zone lot line:

### SECTION 11.10.6 COLLEGE ACCESSORY TO A PLACE FOR RELIGIOUS ASSEMBLY

#### 11.10.6.1 All Zone Districts

In all zone districts, where permitted with limitations:

- A. A College is permitted as accessory to a primary Religious Assembly use only;
- B. The accessory College use shall not have an enrollment greater than 75 students;
- C. The accessory College use shall provide no student or faculty housing; and
- D. The accessory College use shall not operate any activities before 8:00 a.m. or after 6:00 p.m.; ~~and~~
- E. ~~The accessory College use shall provide off-street parking according to the parking requirements for university or college uses in the Urban Neighborhood Context (See Article 5).~~

### SECTION 11.10.7 CONFERENCE FACILITIES ACCESSORY TO HOTEL USE

#### 11.10.7.1 All Zone Districts

In all zone districts, where permitted with limitations:

- A. Conference facilities are permitted as accessory to a primary hotel use.
- B. Notwithstanding the gross floor limitations for accessory uses, conference facilities not exceeding 20 percent of the gross floor area of the hotel are permitted in addition to the floor area occupied by all other accessory uses.
- C. For purposes of this allowance for accessory conference facilities, "gross floor area" shall include net meeting space plus related service and pre-function space.

## SECTION 11.10.14 OUTDOOR GATHERING AREA

### 11.10.14.1 Intent

The Use Limitations in this Section 11.10.14 are intended to:

- A. Encourage Outdoor Gathering Areas that facilitate social gathering opportunities.
- B. Encourage Outdoor Gathering Areas that enhance public streets, public ways and publicly accessible components of private property by adding activation and visual interest.
- C. Integrate Outdoor Gathering Areas thoughtfully with their surroundings.
- D. Ensure an Outdoor Gathering Area remains accessory to the Primary Use permitted on the Zone Lot.
- E. Ensure Outdoor Gathering Areas are designed to be visually subordinate to the Primary Structures with which they are associated.
- F. Promote accessibility for all.
- G. Mitigate potential conflicts between vehicular activity and users of an Outdoor Gathering Area.
- H. Mitigate potential conflicts between an Outdoor Gathering Area and pedestrians.
- I. Ensure vertical elements used to delineate an Outdoor Gathering Area allow visibility into and out of an Outdoor Gathering Area when the Outdoor Gathering Area is visible from public areas or public elements of a private site, such as internal shared paths or common open space areas.
- J. Allow additional design flexibility for an Outdoor Gathering Area that is not visible from public areas or public elements of a site, such as internal shared paths or common open space areas.
- K. Enable flexibility related to ~~required off-street vehicle parking and~~ the Use Limitations for an Outdoor Gathering Area where the proposed design meets the zoning intent and meets or exceeds design guidelines for Outdoor Gathering Areas adopted as rules and regulations.

### 11.10.14.2 Zoning Permit Requirements for Outdoor Gathering Areas

In all zone districts, where permitted with limitations, a zoning permit shall be required for an Outdoor Gathering Area according to the table below:

OUTDOOR GATHERING AREA	RESIDENTIAL ZONE DISTRICTS	MIXED USE COMMERCIAL ZONE DISTRICTS
	Zoning Permit Required (Yes/No)	Zoning Permit Required (Yes/No)
Outdoor Gathering Area is subject to Section 11.10.14.3.D, Limitations When Located Less than 50 feet from a Protected District	Yes	Yes
Outdoor Gathering Area is subject to Section in 11.10.14.3.E, Limitations When Located Between 50 feet and 100 feet from a Protected District	Yes	Yes
Outdoor Gathering Area is accessory to a Primary Eating/Drinking Establishment Use	Yes	Yes
Outdoor Gathering Area contains Permanent Structures, such as a Delineating Element or General Detached Structure	Yes	Yes
Outdoor Gathering Area requires regulatory relief per Section 11.10.14.3.C, Design Flexibility for Outdoor Gathering Areas	Yes	Yes
Outdoor Gathering Area is accessory to a Primary Use other than Eating/Drinking Establishment and only includes movable furnishings, such as umbrellas, picnic tables, benches, tables and chairs	No*	No
* In all Residential Zone Districts, an Outdoor Gathering Area subject to Section 11.4.6, Nonresidential Uses in Existing Business Structures in Residential Zone Districts shall require a zoning permit.		

### 11.10.14.3 All Zone Districts

In all Zone Districts, where permitted with limitations:

- A. Outdoor Gathering Areas are permitted as accessory to a nonresidential use, and shall comply with all applicable limitations stated for the primary use to which the Outdoor Gathering Area is accessory. In case of conflict with the use limitations stated in this section specific to Outdoor Gathering Areas, the more restrictive limitation shall apply.
- B. Except where regulatory relief has been granted by the Zoning Administrator according to Section 11.10.14.3.C, Design Flexibility for Outdoor Gathering Areas, all Outdoor Gathering Areas shall comply with the following limitations:

#### 1. Detached Accessory Structures Covering an Outdoor Gathering Area

A General or Minor Detached Structure, such as a pergola, trellis or similar element, may be used to permanently cover an Outdoor Gathering Area. Except as permitted according to Section 11.10.14.3.B.1.d, such covering shall comply with the following limitations. See Figure 11.10-1.

- a. The entire area of the surface of such covering shall be at least 50% permanently open to the sky and openings shall be evenly dispersed across the surface of the covering; and
- b. A detached permanent structure shall comply with the applicable General or Minor Detached Structure building form standards except the Detached Accessory Structure building form's setback standards shall not apply; and
- c. If walls, fences or other Delineating Elements are integrated into a Detached Accessory Structure, such elements shall comply with Section 11.10.14.3.B.2.

Figure 11.10-1

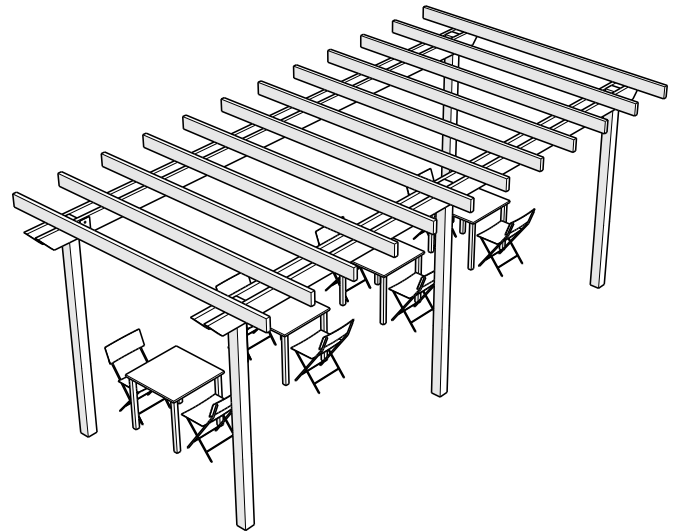
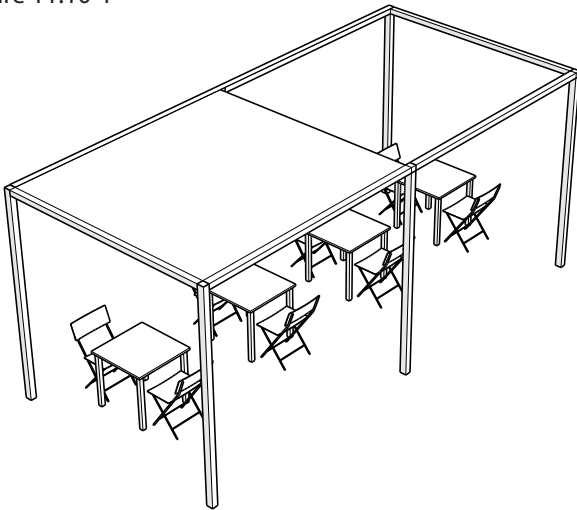

⊗ A Detached Accessory Structure that is 50% permanently open to the sky but does not have evenly distributed openings.

⊙ A Detached Accessory Structure that is 50% permanently open to the sky with evenly distributed openings.

- d. Exceptions include:
  - i. Canvas awnings, umbrellas or other movable or detachable elements may be utilized as shade devices, but shall not enclose any side of a permitted General or Minor Detached Structure. See Figure 11.10-2.

Figure 11.10-6

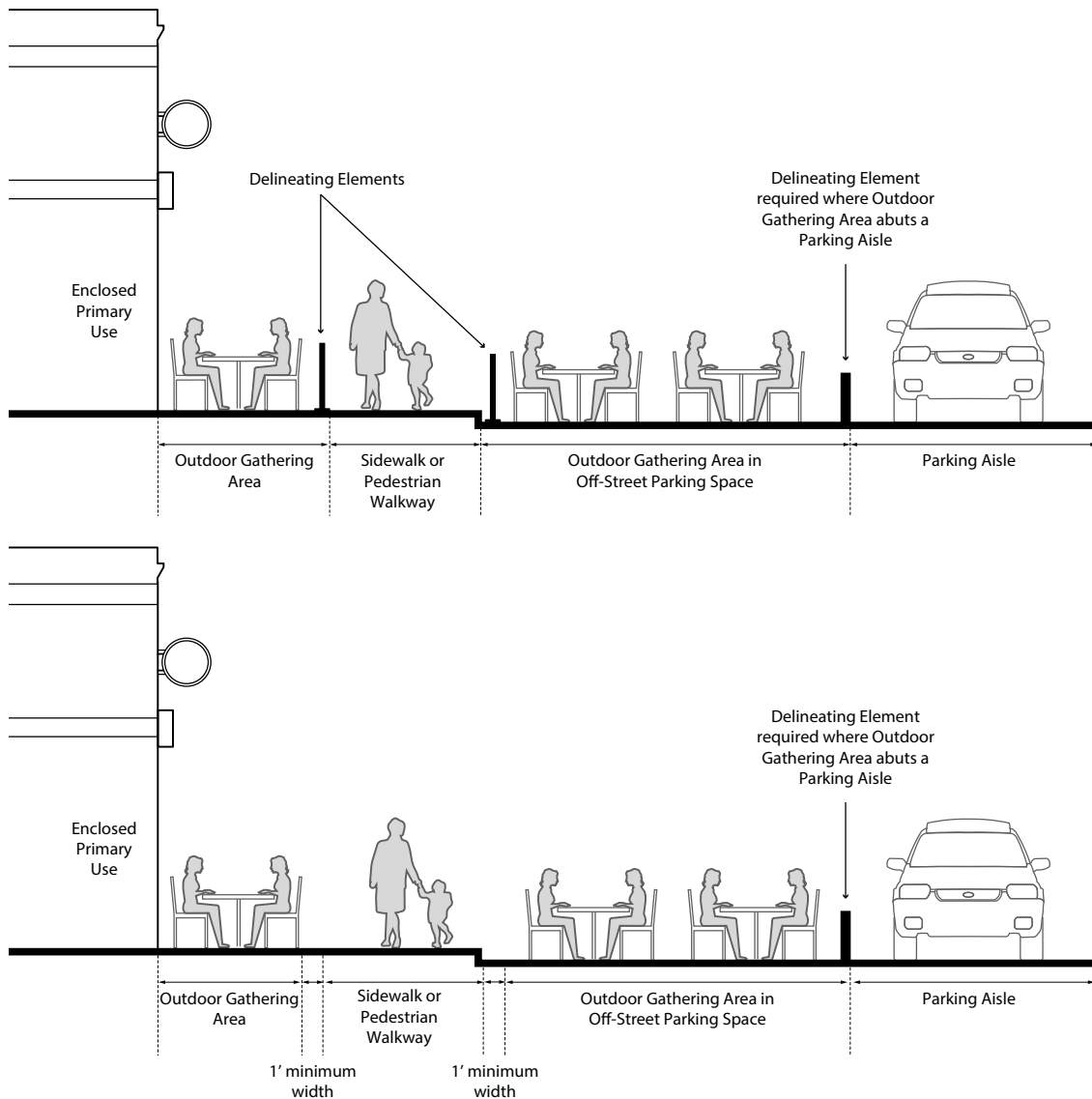

**6. Removal of Required Off-street Parking**

~~Except as allowed in Section 11.10.14.3.C.3, no required off-street parking spaces shall be used for an Outdoor Gathering Area.~~

**7. Allowance for Extension Beyond Zone Lot**

An Outdoor Gathering Area may extend beyond the zone lot containing the Primary Use and into the right-of-way subject to approval and permit by the Department of Transportation and Infrastructure (DOTI).

**C. Design Flexibility for Outdoor Gathering Areas**

**1. Purpose**

This section authorizes regulatory relief from compliance with specified zoning standards when an Outdoor Gathering Area furthers the intent of these Use Limitations through creative design and siting alternatives that exceed the design outcomes of this Section's minimum standards and meet or exceed the design guidelines authorized by Section 11.10.14.3.C.2.

**2. Design Guidelines**

The Manager has the authority to adopt rules and regulations establishing criteria and guidelines for Outdoor Gathering Areas on private property. Any regulatory flexibility identified in this Section 11.10.14.3.C is only available upon adoption of such rules and regulations.

**3. Types of Relief Available**

The Zoning Administrator may provide the following types of regulatory relief if an application for an Outdoor Gathering Area is found to meet the intent of Section 11.10.14.1 and meets or exceeds the design guidelines authorized by Section 11.10.14.3.C.2:

**a. Outdoor Gathering Areas with Limited Public Visibility**

For Outdoor Gathering Areas not visible from the street or other public areas (excluding alleys), or from a highly publicly accessible element of a private multi-tenant site, such as a shared internal pedestrian path, Off-Street Parking Area or internal common outdoor amenity or open space, the Zoning Administrator may waive or modify the following requirements:

- i. Section 11.10.14.3.B.1, Detached Accessory Structures Covering an Outdoor Gathering Area;
- ii. Section 11.10.14.3.B.2, Delineating Elements; and
- iii. Section 11.10.14.3.B.3, Other Structures.

**b. Outdoor Gathering Areas with Enhanced Design**

For Outdoor Gathering Areas found to exceed design standards and guidelines, the Zoning Administrator may waive or modify the requirements of sections 11.10.14.3.B.1 through 11.10.14.3.B.7 for Outdoor Gathering Areas.

**c. Parking**

~~Allow a reduction of required off-street vehicle parking spaces for a Primary Eating and Drinking Establishment use to provide an Outdoor Gathering Area, provided that no required accessible off-street parking spaces may be removed. An Outdoor Gathering Area may reduce up to five required parking spaces per zone lot or up to a maximum percentage of required parking, whichever is greater, according to the table below.~~

ZONE DISTRICT	MAXIMUM NUMBER OF REQUIRED PARKING SPACES	MAXIMUM PERCENTAGE OF REQUIRED SPACES
All Main Street (MS-) Zone Districts	5	80%
All Urban Center (C-) and Campus (CMP-), except Main Street (MS) Zone Districts	5	65%
General Urban (G-), Master Planned (M-) and Industrial Mixed Use (I-MX), except Main Street (MS) Zone Districts	5	45%
Urban (U-) and Urban Edge (E-), except Main Street (MS) Zone Districts	5	35%
Suburban (S-) and Industrial (I-), except Main Street (MS) Zone Districts	5	30%

**d. Enclosure**

Be fully enclosed provided that the number of seats in the enclosed General or Minor Detached Structure shall be no greater than 20 percent of the total permitted occupancy for the permitted Primary Use to which the Outdoor Gathering Area is accessory, and any fully enclosed General or Minor Detached Structure shall comply with all detached accessory building form standards.

**4. Process**

The Zoning Administrator may approve an alternative Outdoor Gathering Area design utilizing the types of flexibility designated in Section 11.10.14.3.C.3. Any request for flexibility will be evaluated in the Zoning Permit review process by staff, subject to the Review Criteria below.

**5. Review Criteria**

An application for an Outdoor Gathering Area seeking flexibility and incentives according to this Section 11.10.14.3.C shall show compliance with the following criteria:

- a. ~~The parking spaces and accompanying access to be waived could otherwise be provided, if not for the reduction.~~
- b. If the proposed reduction relief is located on a Zone Lot containing multiple uses or tenants, the applicant has obtained written approval from the property owner or landlord, as applicable.
- c. The proposed reduction relief is consistent with the intent of the Denver Zoning Code.
- d. The proposed reduction relief meets the intent for an Outdoor Gathering Area as stated in Section 11.10.14.1.
- e. The proposed reduction relief meets or exceeds the design guidelines and standards for an Outdoor Gathering Area established as rules and regulations according to Section 11.10.14.3.C.2.

**D. Limitations When Located Less than 50 feet from a Protected District**

**1. Applicability**

This Section 11.10.14.3.D's use limitations shall apply to all accessory Outdoor Gathering Areas, where permitted with limitations, in the following zone districts:

- a. All RX zone districts
- b. All CC-3x, -5x zone districts
- c. All CC-3, -5 zone districts except when zone district abuts a Commercial Arterial Street as designated in Blueprint Denver
- d. All MX-2x, -2A, -2 zone districts
- e. All MX-3A, -3, -5 zone districts except when zone district abuts a Commercial Arterial Street as designated in Blueprint Denver
- f. All MS-2x, -2 zone districts
- g. All MS-3, -5 zone districts except when zone district abuts a Commercial Arterial Street as designated in Blueprint Denver
- h. All C-CCN zone districts
- i. All I-MX, I-A, I-B zone districts
- j. All M-RX, -IMX, -GMX zone districts

## SECTION 11.10.15 OUTDOOR ENTERTAINMENT ACCESSORY TO AN EATING/ DRINKING ESTABLISHMENT USE

### 11.10.15.1 All Zone Districts

In all zone districts, where permitted with limitations:

- A. Outdoor Entertainment uses are permitted accessory to a primary eating and drinking establishment use only.
- B. Outdoor Entertainment uses are subject to compliance with all applicable standards stated for primary Eating and Drinking Establishments in Section 11.4.9, Eating and Drinking Establishments, All Types. In case of conflict with the use standards stated in this Section specific to Outdoor Entertainment, the standards in this Section shall apply.
- C. All Outdoor Entertainment areas shall comply with the following standards:
  1. The Outdoor Entertainment area shall be contiguous to the Eating and Drinking Establishment to which it is accessory.
  2. The Outdoor Entertainment area shall be clearly delimited by fences, walls or plant materials, but there shall be no structure or enclosure more than 6 feet tall, except that temporary canvas awnings or umbrellas may serve as sun shades.
  3. Any part of the Outdoor Entertainment area located outside of the Completely Enclosed Structure shall have a hard, all weather surface.
  4. ~~No required off-street parking spaces shall be used for an Outdoor Entertainment area.~~
- D. If the Outdoor Entertainment area is less than 100 feet from the boundary of a Protected District (measured according to Section 13.1.11, Measurement of Separation or Distance), the use of the Outdoor Entertainment area and all activities therein shall cease by 10:00 p.m., except on Friday and Saturday nights when the use of the Outdoor Entertainment Area and all activities therein shall cease by 11:00 p.m.
- E. If the Outdoor Entertainment area is less than 50 feet from the nearest boundary of any Protected District (measured according to Section 13.1.11, Measurement of Separation or Distance), it shall be reviewed according to Section 12.4.9, Zoning Permit with Special Exception Review.

## SECTION 11.10.16 OUTDOOR RETAIL SALE AND DISPLAY

### 11.10.16.1 All Zone Districts

In all zone districts, where permitted with limitations, Outdoor Retail Sales and Display shall comply with the following limitations:

- A. **Intent**

To ensure accessory Outdoor Retail Sale and Display areas are located, contained, and designed to be consistent with the general purpose of the applicable zone district.
- B. **Exemption**

Vehicles for sale, lease, or rent as part of a permitted use (including boats and manufactured housing) shall not be considered merchandise, material, or equipment subject to the requirements of this Section 11.10.16.1.
- C. **Location and Placement Standards**
  1. Outdoor retail sales and display areas shall not exceed 20 feet in height.



2. Outdoor retail sales and display areas shall not obstruct the ingress/egress paths to the public way or any required fire access lane or drive aisle abutting such facade. Display of highly combustible goods shall be located at least 5 feet from ingress/egress paths.
3. Outdoor retail sales and display areas shall not obscure visibility of exits or address numbers (premises identification) from the primary street frontage.
4. If located beneath building projections, the outdoor retail sales and display areas area shall be protected by sprinklers if the primary building is protected by sprinklers.
5. Outdoor retail sales and display areas shall be located such that ADA standards are met.
6. Outdoor retail sales and display areas shall be limited in area to no more than 10% of the Gross Floor Area of the Primary Structure(s) on the Zone Lot.
7. Outdoor retail sales and display areas located less than 50 feet from the nearest boundary of a Protected District shall be reviewed according to Section 12.4.9, Zoning Permit with Special Exception Review.
8. Outdoor retail sales and display areas shall not occupy any ~~required off-street parking spaces or~~ areas required to meet any standards in Division 10.5, Landscaping, Fences, Walls, and Screening.
9. [If outdoor retail sales and display areas are located in one or more off street parking spaces, vehicular access and circulation shall be maintained according to the requirements in Section 10.4.6.3, Vehicular Access and Circulation.](#)

#### 11.10.16.2 All C-CCN Zone Districts

##### A. Intent

To ensure that outdoor retail and display areas are located, contained, and designed to be consistent with the intent of the C-CCN zone districts, to promote pedestrian and retail shopping activity at the Street Level, to ensure continuity of storefronts located at the setback line, and to use outdoor spaces to provide settings for activities that contribute to a high-quality pedestrian experience.

##### B. Limitations

In all C-CCN zone districts, where permitted with limitations, Outdoor Retail Sale and Display accessory to a primary nonresidential use shall comply with the limitations in Subsection 11.10.16.1 All zone districts, in addition to the following limitations:

##### 1. Location on Zone Lot

Outdoor retail sale and display shall be located within the boundaries of the subject zone lot. Structures for the outdoor retail sale and display use shall not encroach into the minimum street setback(s) applicable to the primary building. Encroachment of outdoor retail sale and display into the public right-of-way is also prohibited.

##### 2. Relation to Temporary Outdoor Retail Sales

This section's limitations on accessory outdoor retail sale and display do not apply to *temporary* outdoor retail sales permitted in the C-CCN zone districts and subject to Section 11.11.11, Outdoor Retail Sales.

### SECTION 11.10.17 OUTDOOR STORAGE, GENERAL

#### 11.10.17.1 All Zone Districts

In all zone districts, where permitted with limitations, General Outdoor Storage uses shall comply with the following limitations:

- c. The parking of railroad tank cars containing explosive or flammable materials shall be located at least 1,000 feet from a protected use.
  - d. For purposes of this provision only, a “protected use” is any residential use, a hospital, or an auditorium or other building used for public assembly.
2. Liquefied petroleum gases shall be stored no closer to any boundary line of a zone lot on which they are located than that permitted by the Denver Fire Code.
  3. Explosives shall be stored no closer to any boundary line of the zone lot on which they are located than that permitted by the Denver Fire Code.

## **SECTION 11.10.19 RETAIL FOOD ESTABLISHMENT, MOBILE (FOOD TRUCKS)**

### **11.10.19.1 All Zone Districts**

In all zone districts, where permitted with limitations, Retail Food Establishment, Mobile (Food Trucks) accessory uses shall comply with the following limitations:

#### **A. General Allowance as Accessory to Certain Primary Nonresidential Uses**

Mobile Retail Food Establishments (Food Trucks) are allowed as accessory only to the following nonresidential Primary Uses:

1. All specific use types under the primary “Education” use category.
2. The following specific use types included in the more general “Arts, Recreation and Entertainment Services, Indoor” Primary Use, as defined in Section 11.12.4.2.B of this Code:
  - a. Art Gallery
  - b. Artist Studio
  - c. Theater and/or Live Performance Space
  - d. Conference Center, Event Center.
3. Arts, Recreation and Entertainment Services, Outdoor.
4. Sports and/or Entertainment Arena or Stadium.
5. Retail Sales, Service & Repair – Outdoor.
6. Custom Manufacturing, Fabrication & Assembly Primary Uses involving the manufacture of malted beverages, wine, brandy or brandy spirits, or distilled and blended liquors.
7. Within a Campus (CMP) zone district, all permitted Nonresidential Primary Uses except for use types within the “Parking of Vehicles” Primary Use category.

#### **B. Allowed With a Zoning Permit**

Mobile Retail Food Establishments (Food Trucks) authorized by this Section 11.10.19 require a zoning use permit prior to establishment.

#### **C. Siting and Operational Limitations**

##### **1. Number of Food Trucks per Zone Lot**

No more than 1 Mobile Retail Food Establishment (Food Truck) shall be permitted to operate per day at each Zone Lot, with the exception that there is no limit when accessory to either of the following Primary Uses:

- a. Outdoor Arts, Recreation and Entertainment,
- b. Sports and/or Entertainment Arena or Stadium, or
- c. Within a Campus (CMP) zone district, all permitted Nonresidential Primary Uses except for use types within the “Parking of Vehicles” primary use category.

**2. Minimum Distance Required from Residential Zone Districts**

An accessory Mobile Retail Food Establishment (Food Truck) shall be parked and shall conduct all parts of its operations a minimum distance of 50 feet from the closest boundary line of a Residential Zone District.

**3. Siting and Location**

- a. Operations shall occur on the same Zone Lot as the Primary Use.
- b. The location of the use shall be on a paved or other similar weatherproof and durable surface to support the weight of the food truck and prevent wear and tear of the surface.
- c. ~~The location of the use shall not reduce the area required for parking for any other use located on the Zone Lot.~~
- d. The location of the use shall not obstruct the visibility of motorists, nor obstruct parking lot circulation, or block access to a Public Street, Alley, or sidewalk.

**4. Hours of Operation and Other Operational Limits**

- a. Except as further limited in this Section 11.10.19.1.C, the accessory Mobile Retail Food Establishment (Food Truck) shall operate only during the time that the Primary Use is open to the public for business.
- b. In addition to the hours above, when accessory to an Arts, Recreation and Entertainment Services Primary Use or to a Sports and/or Entertainment Arena or Stadium Primary Use, the Mobile Retail Food Establishment (Food Truck) shall operate only during the time an event, performance, or activity is occurring that is open to the public (regardless of an admission fee charge).

**For example**, a Food Truck may operate during the hours of a “First Friday” open house that is open to the public at a permitted Art Gallery use; or during the hours that a stadium or arena is hosting a sporting event or concert.

- c. Operators of the Mobile Retail Food Establishment (Food Truck) shall be responsible for the storage and daily disposal of all trash, refuse, and litter.
- d. Outdoor Storage associated with a Mobile Retail Food Establishment (Food Truck) is prohibited.

**5. Signage**

- a. Signs must be permanently affixed to or painted on the Mobile Retail Food Establishment (Food Truck).
- b. Signs shall not project from the Mobile Retail Food Establishment (Food Truck) and shall not be illuminated or animated.

**SECTION 11.10.20 RENTAL OR SALES OF ADULT MATERIAL ACCESSORY TO RETAIL SALES OF BOOKS**

**11.10.20.1 All Zone Districts**

In all zone districts, where permitted with limitations, if a bookstore rents or sells adult materials, as described in the definition of “Adult Bookstore” (see Section 11.12.4.1.B.2, Adult Bookstore), as an accessory use, such accessory use shall comply with the following limitations:

- A. The quantity of adult materials displayed or sold shall not exceed the numerical limitations specified in the definition for “Adult Bookstore”;
- B. All adult materials shall be segregated into a separate section of the bookstore and screened from public view; and
- C. Access to the adult materials shall be denied to all persons under the age of 18 years.

## DIVISION 11.11 TEMPORARY USE LIMITATIONS

The Use ~~and Parking~~ Tables in Articles 3 through 9 reference any limitations applicable to permitted primary, accessory, or temporary uses. This Division contains limitations applicable to specific temporary uses across multiple zone districts and neighborhood contexts. Temporary uses are permitted according to Section 12.4.1, Zoning Permit Review, and subject to compliance with this Division's use-specific standards, as applicable. Structures used to house permitted temporary uses are not required to comply with primary or accessory building form standards. ~~Temporary uses may occupy one or more minimum required Off-Street Parking Spaces unless specifically prohibited in this Division 11.11's use limitations below.~~

### SECTION 11.11.1 UNLISTED TEMPORARY USES

#### 11.11.1.1 All Zone Districts

In all zone districts, where permitted with limitations:

- A. The Zoning Administrator may allow and impose limitations on unlisted temporary uses according to this subsection 11.11.1.
- B. All such determinations shall be reviewed according to the procedures and review criteria stated Section 12.4.6, Code Interpretations and Determination of Unlisted Uses.

### SECTION 11.11.2 AMBULANCE SERVICE

#### 11.11.2.1 All Zone Districts

In all zone districts, where permitted with limitations:

- A. Not more than 2 ambulances at any one location;
- B. Vehicles to be parked in Completely Enclosed Structure when not in use;
- C. No mechanical or maintenance work is to be done on premises and no gasoline is to be stored there;
- D. No office is to be maintained in connection with the temporary ambulance service use; and
- E. Each permit shall be valid for a period of not more than 6 months, but may be renewed; provided, however, that failure to comply with any of these standards shall be cause for revocation of any permit.

### SECTION 11.11.3 AMUSEMENT / ENTERTAINMENT USES

#### 11.11.3.1 All Industrial Context Zone Districts; O-1 Zone District; CMP-H Zone Districts; and the CMP-NWC, CMP-NWC-C, CMP-NWC-G, CMP-NWC-F and CMP-NWC-R Zone Districts

In all Industrial Context zone districts, the O-1 zone district, the CMP-H and CMP-H2 zone districts, and the CMP-NWC, CMP-NWC-C, CMP-NWC-G, CMP-NWC-F, and CMP-NWC-R zone districts, where permitted with limitations, a temporary amusement, entertainment or recreational use on the payment of a fee or admission charge shall comply with the following standards:

- A. The temporary use shall not be enclosed.
- B. The temporary use shall be a minimum of 500 feet from a Residential Zone District.
- C. Each permit shall be valid for a period of not more than 6 calendar months, but may be renewed.

## SECTION 11.11.11 OUTDOOR RETAIL SALES

### 11.11.11.1 All Mixed Use Commercial Zone Districts; OS-B Zone District

In all Mixed Use Commercial Zone Districts and in the OS-B zone district, where permitted with limitations, temporary outdoor sales involving the sale and display of goods and merchandise as an extension of a primary use operating on the same zone lot, shall comply with the following standards:

- A. Each permit for the proposed use shall be valid for a period of not more than 45 days with one renewal for a period of not more than 30 days during any six month period, if all requirements hereof have been complied with during the original permit period.
- B. ~~No required off-street parking space will be used for such merchandise display, storage or dispensing.~~
- C. The proposed use must be set back at least 30 feet from the curb of a public street and at least 150 feet from a single unit or two unit dwelling use.
- D. No part of the proposed use shall obstruct visibility of motorists if located near a street corner or driveway entrance, nor shall such use obstruct the parking lot circulation system or block access to a public street.
- E. No temporary structure erected in conjunction with the proposed use shall be built out of used or unpainted lumber or rusty metal, or similar material as determined by the Zoning Administrator. Tents are permitted, subject to Fire Department regulations.
- F. Notwithstanding more restrictive signage regulations found elsewhere, a maximum of 24 square feet of sign area is permitted for each use. Signage shall be limited to the walls or side of a tent, or structure or to a single freestanding sign which is not more than 24 square feet in area per sign face. The maximum sign area provisions of Division 10.10, Signs, shall not apply to this use.
- G. The applicant shall be responsible for the storage and daily removal of all trash, refuse and debris occurring on the site. All trash storage areas shall be screened from the view of persons using adjacent rights of way.
- H. This provision shall in no way be deemed to authorize the outdoor sale of used furniture, used appliances, used plumbing, used housewares, used building materials or similar items.

## SECTION 11.11.12 OUTDOOR SALES, SEASONAL

### 11.11.12.1 All RX Zone Districts, All Mixed Use Commercial Zone Districts, I-A Zone District, and OS-B Zone District

In all RX zone districts, all Mixed Use Commercial Zone Districts, the OS-B zone district, and the I-A zone district, where permitted with limitations, temporary seasonal outdoor sales, not limited to the sale and display of goods and merchandise as an extension of a permitted use operating on the same zone lot, are permitted subject to compliance with the following limitations.

**A. Sale of Christmas Trees and Related Holiday Items**

In all zone districts, where temporary seasonal outdoor sales are permitted with limitations, the seasonal outdoor retail sales of Christmas trees, wreaths, and other related holiday goods shall comply with the following limitations:

1. In all RX zone districts, Section 12.4.2, Zoning Permit with Informational Notice shall apply.
2. In the MX-2x and MS-2x zone district, when located within 500 feet of a Residential Zone District, Section 12.4.2, Zoning Permit with Informational Notice, shall apply.
3. No permit shall be effective prior to the 1st day of November in each calendar year;
4. No permit shall be valid for a period of more than 60 days; and
5. Site cleanup shall be completed no later than 5 days after Christmas day.

**B. Sale of Plants or Plant Sales Facilities**

In all zone districts, where temporary seasonal outdoor sales are permitted with limitations, seasonal plant sales facilities shall comply with the following limitations:

1. In all RX zone districts, Section 12.4.2, Zoning Permit with Informational Notice shall apply.
2. In a MX-2x and MS-2x zone district when located within 500 feet of a Residential Zone District, Section 12.4.2, Zoning Permit with Informational Notice shall apply.
3. The applicant is the owner of the subject property or has written consent of the owner.
4. The proposed temporary use shall be operated wholly or partially within a temporary structure, which is not a motor vehicle or trailer.
5. The proposed temporary use, not including parking, encompasses an area of no more than one acre.
6. Permits shall be valid from April 1 through October 31 of each calendar year.
7. ~~Parking shall be provided to encompass a minimum area equal to one-half the covered and uncovered retail sales area proposed at the facility. The Zoning Administrator may reduce or eliminate this off-street parking requirement if the applicant shows by a preponderance of the evidence that alternative parking is available and convenient to the proposed use, including but not limited to nearby on-street parking, public parking facilities, or commercial parking lots or garages. If provided on-site, the seasonal plant sales facility includes a new temporary off-street parking area, parking surfaces the surface of the off-street parking area shall be either paved or shall consist of a dust-free road base or acceptable gravel base material; and the ground area to be occupied by the proposed use shall not reduce the area occupied by the required parking of an existing permitted use on the zone lot by more than ten percent.~~
8. Vehicle access to the proposed facility shall provide appropriate ingress and egress areas to preclude traffic congestion on adjacent streets.
9. A security fence shall be installed around the entire area of the proposed facility consisting of an approved fencing material such as wire mesh at a height of not less than 6 feet.
10. Any advertising signage at the proposed facility shall be in place only during the proposed operations of the facility; signage shall be limited to a maximum of 50 square feet per face with no more than two signs for each street frontage of the proposed facility; and all signs shall be non-portable and shall conform to zone district setback requirements.

11. Adequate utilities including water and electricity, as well as restroom facilities for the employees of the applicant, are available at or can be provided to the facility.
12. Lighting shall be provided for evening and night operations.
13. The proposed temporary use shall be operated in a manner that does not emit any obnoxious or dangerous degrees of heat, light, glare, or fumes beyond any boundary line encompassed by the facility.

**C. All Other Types of Temporary Outdoor Sales, Seasonal**

1. In all RX zone districts, Section 12.4.2, Zoning Permit with Informational Notice, shall apply.
2. In all MX-2x, -2A, -2 and MS-2x, -2 zone districts, when located within 500 feet of a Residential Zone District, Section 12.4.2, Zoning Permit with Informational Notice, shall apply.
3. Permits shall be valid for no longer than 6 consecutive months of any one calendar year, unless more specifically restricted in this Section.
4. Hours of operation are limited to 8:00 a.m. to 8:00 p.m. daily.
5. ~~The temporary use shall provide off-street parking in an amount equal to one-half of the covered and uncovered retail sales area proposed at the facility. The Zoning Administrator may reduce or eliminate this off-street parking requirement if the applicant shows by a preponderance of the evidence that alternative parking is available and convenient to the proposed use, including but not limited to nearby on-street parking, public parking facilities, or commercial parking lots or garages. If provided on-site, the temporary outdoor sales facility includes a new temporary off-street parking area, parking surfaces the surface of the off-street parking area shall either be paved or consist of a dust-free road base or acceptable gravel base material; and the ground area to be occupied by the proposed temporary use shall not reduce the area occupied by the required parking of an existing permitted use on the zone lot.~~
6. The temporary use shall comply with the setback requirements for the zone district in which it is located and shall be at least 50 feet from any Residential Zone District.
7. The temporary use shall not obstruct the visibility of motorists, nor obstruct the parking lot circulation or block access to a public street.
8. Temporary structures associated with the temporary seasonal outdoor use shall be limited to no more than 200 square feet in gross floor area and shall obtain all required building and safety permits from the Fire Department, Environmental Health Department, and Community Planning and Development.
9. Any electrical work shall be duly permitted by the City prior to operation of the temporary use and related structures.
10. Signs shall be limited to not more than two ground or wall signs as defined in Article 13, Rules of Measurement and Definitions, with a total area not exceeding 24 square feet and located on the same zone lot as the seasonal outdoor sales. Such signs shall meet the most restrictive setback requirements of the zone district in which they are located.
11. The applicant shall be responsible for the daily storage and removal of all trash, refuse, and debris. All trash storage facilities shall be provided with screening adequate to fully conceal such facilities from adjacent properties.
12. No truck-tractors or semi-trailers shall be parked or stored on or adjacent to the seasonal outdoor sales area.

1. The surface Off-Street Parking Area shall be improved with an all-weather surfacing material comprised, at a minimum, of gravel or road base material with a thickness of at least 4 inches.
2. The dimensions for and the arrangement of parking spaces and driving aisles shall comply with Section 10.4.6, Vehicle Parking Design.

### **11.11.13.3 All I-A, I-B, OS-B, and O-1 Zone Districts**

In all I-A, I-B, OS-B, and O-1 zone districts, where permitted with limitations:

- A. Each permit for temporary surface Off-Street Parking Area for a designated special event shall be valid only for the duration of the designated event; provided, however, if the designated special event is a seasonal activity, the permit may be granted for the entire season but restricted in use to designated dates and times in which the event is occurring.
- B. Except in the O-1 and OS zone districts, a temporary surface Off-Street Parking Area shall be improved with an all-weather surfacing material comprised, at a minimum, of gravel or road base material with a thickness of at least 4 inches.

### **11.11.13.4 All Zone Districts - Posted Sign Required**

- A. At each legal vehicle entry from the public street, no more than one advertising or directional sign may be installed, which shall be limited in size to 12 square feet.
- B. All signs related to the temporary surface Off-Street Parking Area shall be installed only during the time of the special event, shall not exceed a height of 6 feet, and need not be set back from any property line.
- C. Each parking lot shall have one sign 6 square feet in area which is installed on the front property line and which contains the following information printed in letters 2 inches high:
  1. Owner's name
  2. The temporary permit number
  3. Number of cars permitted in the lot
  4. The designated special event for which the parking is permitted

## **SECTION 11.11.14 RETAIL FOOD ESTABLISHMENT, MOBILE (FOOD TRUCKS)**

### **11.11.14.1 All Mixed Use Commercial Zone Districts; I-A, I-B Zone Districts; OS-B Zone District**

In all Mixed Use Commercial Zone Districts; I-A, I-B zone districts; and OS-B zone district, where permitted with limitations, Temporary Mobile Retail Food Establishments (Food Trucks) are permitted subject to compliance with the following standards:

#### **A. Allowed to Operate Concurrent with Certain Other Temporary Uses**

##### **1. Concurrent with Other Temporary Uses**

Temporary Mobile Retail Food Establishments (Food Trucks) may be established and operated, subject to the general limitations in Section 11.11.14.1.B and any additional specific limits stated in this Section 11.11.14.1.A, on the same Zone Lot as the following Temporary Uses:

- a. Bazaar, Carnival, Circus, or Special Event
- b. Outdoor Sales, Seasonal (e.g., seasonal farmers markets)
- c. Amusement/Entertainment - Temporary
- d. Parking Lot Designated for a Special Event



## 2. Use and Operational Limitations

Temporary Mobile Retail Food Establishments (Food Trucks) established according to this subsection 11.11.14.1.A are subject to the following limitations:

- a. All Temporary Uses must be allowed in the subject zone district and permitted according to this Code.
- b. A Temporary Mobile Retail Food Establishments (Food Trucks) use shall only operate during the same hours that the other temporary use is operating and open to the public for the permitted outdoor seasonal sales, special event, or amusement/entertainment.

## B. General Limitations

Temporary Mobile Retail Food Establishments (Food Trucks) are permitted subject to compliance with the following standards:

### 1. Zoning Permit Not Required for Short Durations

- a. A zoning permit is not required when the duration of a proposed Temporary Mobile Retail Food Establishment (Food Trucks) operating on the same subject Zone Lot is 12 consecutive days or less.
- b. The Temporary Mobile Retail Food Establishment (Food Truck) operator shall comply with all other applicable standards and limitations stated in this Section 11.11.14 and this Code.

### 2. General Siting and Operational Limitations

- a. Permits shall be valid for 12 consecutive months and shall be renewed annually.
- b. Operations shall be located at least 50 feet from any Residential Zone District.
- c. Except when permitted to operate concurrently with another Temporary Use listed in Section 11.11.14.A., no more than 1 Food Truck shall be permitted to operate per day at each zone lot.
- d. Operations shall only occur on zone lots ~~and shall not reduce the area required for parking for any other use on the zone lot.~~
- e. Operations shall not obstruct the visibility of motorists, nor obstruct parking lot circulation or block access to a public street, alley or sidewalk.
- f. Hours of operation shall be between 8:00 a.m. and 9:00 p.m.
- g. Operations shall not occur outside of the Temporary Mobile Retail Food Establishments (Food Trucks).
- h. Operators shall be responsible for the storage and daily disposal of all trash, refuse, and litter.
- i. Operators shall not cause any liquid wastes used in the operation, with the exception of clean ice melt, to be discharged from the Temporary Mobile Retail Food Establishments (Food Trucks).
- j. Signs must be permanently affixed to or painted on the Temporary Mobile Retail Food Establishments (Food Trucks).
- k. Signs shall not project from the Temporary Mobile Retail Food Establishments (Food Trucks) and shall not be illuminated or animated.

## SECTION 11.11.15 TEMPORARY CONSTRUCTION OFFICE

### 11.11.15.1 All Zone Districts

In all zone districts, where permitted with limitations, temporary construction offices needed for a specific construction project are permitted provided each permit shall be valid for a period of not more than 12 calendar months and shall not be renewed for more than three successive periods at

## DIVISION 11.12 USE DEFINITIONS

This Division 11.12 contains definitions of primary, accessory and temporary uses permitted in this Code. The Division is organized in the same order as uses are presented in the Use ~~and Parking~~ Tables in Articles 3 through 9, with specific use definitions organized by sections and sub-sections that align with the primary use classifications and use categories, followed by sections for accessory uses and temporary uses.

### SECTION 11.12.1 PRIMARY USE CLASSIFICATION

11.12.1.1 All primary or principal land uses in Denver are organized into one of the following five general land use classifications:

- A. Residential Uses
- B. Civic, Public & Institutional Uses
- C. Commercial Sales, Service & Repair Uses
- D. Industrial, Manufacturing & Wholesale Uses
- E. Agriculture Uses

11.12.1.2 Uses are further organized into use categories and specific use types listed under each general land use classification. A definition of a specific use type shall also meet the definition of the use category in which it falls. The Use ~~and Parking~~ Tables in Articles 3 through 9 are all similarly organized into the above five general land use classifications, use categories and specific use types.

11.12.1.3 The general land use classifications and use categories listed in this Division are intended to be mutually exclusive; that is, a use classified into one use category, such as “lodging accommodations,” cannot be classified in a different use category, such as “residential care,” unless otherwise expressly permitted by this Code.

### SECTION 11.12.2 PRIMARY RESIDENTIAL USES

#### 11.12.2.1 Definition of Household Living Use Category

##### A. Definition of Category

1. Household Living is defined as residential occupancy of a “dwelling unit” by a single “household.” Tenancy is arranged on a month-to-month or longer basis.

##### B. Definitions of Related Terms

###### 1. Dwelling Unit

One or more Rooms constituting a unit for permanent occupancy, having but one kitchen together with facilities for sleeping, bathing, and which unit occupies a structure or a portion of a structure. A Dwelling Unit may be either Primary or Accessory, defined as follows:

###### a. Primary Dwelling Unit

A Dwelling Unit that contains a primary residential use.

###### b. Accessory Dwelling Unit

See the definition of Accessory Dwelling Unit in Section 11.12.7.1.

###### 2. Household

- a. A “household” is any number of persons, plus any permitted domestic service workers, who all occupy a Dwelling Unit who share household activities and responsibilities, such as meals, chores, rent, and expenses. The choice of specific adults comprising the household is determined by the members of such household

- g. **Skateboard Centers or Parks**
  - h. **Swimming Pools, Outdoor**
  - i. **Tennis Clubs, Outdoor**
  - j. **Outdoor Theaters, Amphitheaters, or Other Permanent Outdoor Performance Spaces**
- 3. Event Space with Alternate Parking and Loading**  
Commercial establishments engaged in providing outdoor amusement, recreation or entertainment services by and for participants, often for the payment of a fee or admission charge, excluding Community Center and adult business uses. The outdoor event space may be used alternately as an Off-Street Parking Area or for Loading.
- 4. Sports and/or Entertainment Arena or Stadium**  
Commercial establishments designed, intended, or used primarily for indoor or outdoor large-scale spectator events including, but not limited to, professional and amateur sporting events, concerts, theatrical presentations, or motor vehicle racing. Typical uses include coliseums, arenas and sports stadiums.

#### 11.12.4.3 Parking of Vehicles

**A. Definition of Parking of Vehicles Use Category**

Parking of Vehicles is a use category including the commercial assembly or standing of vehicles, either in a garage structure or on a surface lot.

**B. Specific Parking of Vehicles Use Types and Definitions**

**1. Parking, Garage**

- a. Any structure, other than a private garage, for the assembling, or standing of vehicles in a structure for relatively temporary periods of time, either with or without charge for such assembling and standing, but not for repair, sale, dismantling, or commercial storage thereof.
- b. The term “Garage Parking” includes underground parking, which means a parking surface that is located a minimum of 8 feet below the Street Level and is covered by a structure which provides a surface for another use.
- c. A parking garage may include accessory off-street parking spaces ~~required or~~ permitted under this Code.

**2. Parking, Surface**

The assembling or standing of vehicles on a surface parking lot for relatively temporary periods of time either with or without charge for such assembling and standing, but not for repair, sale, dismantling, or commercial storage thereof.

#### 11.12.4.4 Eating & Drinking Establishments

**A. Definition of Eating & Drinking Establishments Use Category**

Commercial establishments engaged primarily in the sale of food or drink to consumers for on-premises or off-premises consumption. Any Automobile Fueling Station located on the same Zone Lot shall be assigned a Primary Use of “Automobile Services, Light.”

**B. Specific Eating & Drinking Establishments Use Types and Definitions**

**1. Eating and Drinking Establishment**

A retail establishment primarily engaged in the sale of prepared, ready-to-consume food and/or drinks within a Completely Enclosed Structure. Typical uses include restaurants, fast-food outlets, snack bars, taverns, bars and brewpubs.

**2. Brewpub**

A specific type of eating and drinking establishment. A facility at which malt, vinous, or spirituous liquors are manufactured on the premises, bottled, and sold on the same premises as where the eating and drinking services are provided. No more than 30% of the manufactured product may be sold to off-premises customers. The volume of liquor manufactured on the premises of the brewpub shall not exceed 300 gallons per day each calendar year.

**11.12.4.5 Lodging Accommodations**

**A. Definition of Lodging Accommodations Use Category**

Lodging accommodations uses are characterized by visitor-serving facilities that provide temporary lodging in guest rooms or guest units, for compensation, and with an average length of stay of less than 30 days. Accessory uses may include pools and other recreational facilities for the exclusive use of guests, limited storage, restaurants, bars, meeting facilities, and offices, but excludes Short-term Rentals as defined in Section 11.12.7.7.

**B. Specific Lodging Accommodations Use Types and Definitions**

**1. Bed and Breakfast Lodging**

A manager-occupied residential structure providing rooms for temporary, overnight lodging, with or without meals, for paying guests. A Bed and Breakfast may provide simultaneous lodging to different parties under separate contracts.

**2. Extended Stay Hotel**

A hotel containing guest rooms oriented to allow independent housekeeping for occupancy by the week or by the month, or some portion thereof, with facilities for sleeping, bathing, and cooking.

**3. Hotel**

One or more buildings providing temporary lodging primarily to persons who have residences elsewhere, or both temporary and permanent lodging in guest rooms, or apartments. The building or buildings have an interior hall and lobby with access to each room from such interior hall or lobby.

**4. Hostel**

A nonprofit facility located in a residential structure and associated with a national or international hostel organization, which facility has but one kitchen and provides sleeping accommodations for not more than 25 persons. All housekeeping duties are shared by the occupants under the supervision of a resident manager.

**5. Motel**

One or more buildings providing residential accommodations and containing rental rooms and/or dwelling units, each of which has a separate outside entrance leading directly to rooms from outside the building. Services provided may include maid service and laundering of linen, telephone and secretarial or desk service, and the use and upkeep of furniture. Up to 20 percent of the residential units may be utilized for permanent occupancy.

#### 11.12.4.6 Office

##### A. Definition of Office Use Category

The Office use category is defined as uses where services are performed for predominately administrative, professional, medical, dental or clerical operations that function as a place of business for any of the following: accountants, architects, attorneys, bookkeeping services, brokers (of stocks, bonds, real estate), building designers, corporate offices, drafting services, dentists, doctors, financial institutions, development companies, engineers, surveyors and planners, insurance agencies, interior decorators and designers, landscape architects, psychiatrists, psychologists, notaries, typing and secretarial services, therapists, and internet publishing, broadcasting, and web search portal establishments, and other similar businesses and professions, not otherwise specifically defined in this Code or separately listed in the Use ~~and Parking~~ Tables.

The Office Use Category also include business operations typically less service-oriented than the more traditional office uses listed above, including but not limited to: (1) software and internet content development and publishing; (2) computer systems design and programming; (3) graphic and industrial design; (4) data processing or call centers; (5) facilities that broadcast exclusively over the Internet and have no live, in-building audiences participating in such broadcasts; (6) scientific and technical services; and (7) medical and/or dental laboratories.

Contractors and others who perform services off-site but who store major equipment and materials on the site are not included in this use category.

##### B. Specific Office Use Types and Definitions

###### 1. Dental / Medical Office or Clinic

An office use where the primary service is the treatment of patients or clients for physical or mental ailments and disorders, and which may also include passive (non-intrusive) research involving human subjects. Examples include doctor or dentist offices and clinics, and treatment of persons with eating disorders, sleep clinics, and other similar clinic uses. This use excludes hospital and animal hospital uses.

#### 11.12.4.7 Retail Sales, Service & Repair (Not Including Vehicle or Equipment Sales, Service & Repair)

##### A. Definition of Retail Sales, Service & Repair Use Category -- Not Including Vehicle or Equipment Sales, Services & Repair

1. The Retail Sales, Service and Repair use category includes commercial establishments involved in the retail sale of new or used products, and the retail provision of consumer, repair, or rental services to individuals, households, and businesses. Any Automobile Fueling Station located on the same Zone Lot shall be assigned a Primary Use of "Automobile Services, Light."
2. This category includes but is not limited to:
  - a. Banking and financial services,
  - b. Food sales,
  - c. Animal sales and services,
  - d. General merchandise sales,
  - e. Personal and personal care services (e.g., dry cleaning and laundry services, hair/nail salons, tanning salons, day spas, and funeral homes, and mortuaries including accessory crematory services), and

- b. Repair or refurbishing of small-scale personal or household goods and items, such as countertop appliances, jewelry, watches, personal sporting equipment, non-motorized vehicles such as bicycles or skateboards, and similar items.
- c. Repair or refurbishing of small-scale business goods and item, such as phones, computers, printers, and similar types of office equipment and supplies.
- d. Learning center or tutoring services for adults or children.

**10. Office, Non-Medical, Non-Dental**

See Section 11.12.4.6.A, Definition of Office Use Category, but not including Dental / Medical Office or Clinic.

**11. Online Retail Sales**

Online Retail Sales are retail or wholesale sales where the transaction originates on and is completed on the Internet via an individual website or a third party marketplace. Online Retail Sales may include the sale of handmade or craft goods created, fabricated or assembled on the residential premises. Online Retail Sales are distinguished from Retail Sales or Wholesale in that goods or services are not transferred directly to a buyer at the residential premises.

**12. Professional Studio**

See definition of “Professional Studio” in Section 11.12.4.2.B, Specific Arts, Entertainment & Recreation Use Types and Definitions.

## **SECTION 11.12.9 DEFINITIONS OF USES ACCESSORY TO PRIMARY NONRESIDENTIAL USES**

**11.12.9.1 Amusement Devices**

An electronic or mechanical device which operates as a game, contest or amusement of any description and which includes but is not limited to pinball machines, video games, foosball machines or similar devices. This term does not include musical devices, children’s rides, or pool and/or billiard tables.

**11.12.9.2 Automobile Rental Services**

The rental of automobiles under conditions where (1) the storage of all rental automobiles is located on the same zone lot as the office for the automobile rental service, and (2) no mechanical or maintenance work on automobiles shall be done on the premises; and (3) the land area assigned for storage of rental automobiles shall not be included for computation of any ~~required~~ maximum off-street parking ~~space~~standard.

**11.12.9.3 Car Wash Bay**

Washing, cleaning, and/or waxing of private automobiles, light trucks and vans, but not commercial fleets, by hand or with manually operated equipment or automatic machinery.

**11.12.9.4 College Accessory to a Place for Religious Assembly**

A post-secondary education facility operated by a place for religious assembly and physically located on a zone lot occupied by such place for religious assembly.

**11.12.9.5 Conference Facilities**

A facility which provides meeting halls, trade centers, merchandise marts, or convention centers for training and other gatherings for large numbers of people for similar functions; may be developed separately or in combination with another permitted use.

4. Consistency with the intent of any changes to the Denver Comprehensive Plan or this Code that have occurred since the original approval date and that affect the subject Development.
- F. Additional review of the application, permit or plan may result in additional conditions placed on the extended approval, application, permit or plan, as applicable.
- G. The grant of an extension shall be effective and counted as of the date of the original permit or plan's approval period expiration date and not the date the extension request is approved.
- H. If the extension is denied, the applicant may re-submit a new application, subject to the fees, standards, and regulations in effect at the time of re-submittal, for the same project.

## SECTION 12.3.7 MODIFICATION OR AMENDMENT OF APPLICATIONS, PLANS AND PERMITS

### 12.3.7.1 Modifications to Pending or Approved Applications, Plans or Permits

#### A. **Applicability**

1. This Section 12.3.7.1 shall not apply to modifications to LDFs, IMPs, or GDPs; instead, see Sections 12.4.12, Large Development Review, and 12.4.14, Infrastructure Master Plan.
2. For purposes of this Section 12.3.7.1-A-2, the phrase "site development plan" shall also include site development plans previously approved under Former Chapter 59 that are applicable to land zoned and mapped under the Denver Zoning Code. Site development plans under Former Chapter 59 include site plans approved according to Former Chapter 59, Article VIII - Special Zone Lot Plans for Planned Building Groups.
3. The ~~following types of~~ minor modifications, changes, removal, or release of either (1) the Code standards applicable to a pending application; or (2) the Code provisions applicable to, or the conditions attached to, an approved application, plan, or permit described in this Section 12.3.7.1, shall be treated as "modifications" rather than "amendments," and may be approved administratively by the Zoning Administrator according to this Section.

#### B. **Modifications to Regulating Plans, Site Development Plans or Zoning Permits**

1. Modifications to a pending or approved regulating plan, site development plan, or zoning permit application that are expressly permitted as "administrative adjustments" under Section 12.4.5, Administrative Adjustment, may be approved by the Zoning Administrator according to the procedures and criteria in Section 12.4.5.
2. Modifications to an approved regulating plan, site development plan, or zoning permit to reduce or eliminate the minimum number of vehicle parking spaces required shall be submitted to the Zoning Administrator for review and approval under this Section 12.3.7.1. Such modification may include withdrawal from participation in plans or programs previously required, such as shared parking or off-site parking plans or agreements.
3. The Zoning Administrator may allow one or more Accessory Dwelling Unit uses in excess of any specified number of dwelling units or maximum density in an approved regulating plan or site development plan according to the applicable procedure specified below.
  - a. **Accessory Dwelling Units in a Plan-allowed Structure**  
Where the Accessory Dwelling Unit use will be located within a Primary Structure or Detached Accessory Structure that is allowed by an approved regulating plan or site development plan, and the building footprint of the approved structures will not be expanded, the Accessory Dwelling Unit may be approved by Zoning Permit.

**b. Accessory Dwelling Units With Expanded Building Footprint**

Where an Accessory Dwelling Unit use will be located in a Primary Structure or Detached Accessory Structure and the building footprint(s) will be expanded beyond those shown in an approved regulating plan or site development plan, the Accessory Dwelling Unit may be approved by modification to the approved regulating plan or site development plan.

**c. ~~Site Development Plans Approved Under Former Chapter 59~~**

~~For purposes of this Section 12.3.7.1.A.2, the phrase "site development plan" shall also include site development plans previously approved under Former Chapter 59 that are applicable to land zoned and mapped under the Denver Zoning Code. Site development plans under Former Chapter 59 include site plans approved according to Former Chapter 59, Article VIII – Special Zone Lot Plans for Planned Building Groups.~~

4. The Zoning Administrator may allow minor changes to an approved regulating plan, site development plan or zoning permit provided such minor changes do not constitute an "amendment" under Section 12.3.7.2.B, "Amendments to Approved Regulating Plans, Site Development Plans and Zoning Permits," below.
5. All modifications to an approved regulating plan, site development plan or zoning permit shall be submitted to the Zoning Administrator for review and approval.
6. The applicable standards for review of modifications to an approved regulating plan, site development plan or zoning permit are those standards in effect at the time a final decision is made on the modification, unless otherwise expressly allowed by a duly adopted ordinance of the City Council.
7. After approval, the Zoning Administrator shall record a modified regulating plan or site development plan in the records of the Denver County Clerk and Recorder's Office, and shall register a modified zoning permit in the records of Community Planning and Development.

**C. Other Modifications to Approved Applications, Plans, or Permits**

1. Changes, modifications, removal, or release of all or some of the provisions of an approved application, plan, or permit, which do not otherwise qualify as "modifications" under Section 12.3.7.1.A above, or as an "amendment" under Section 12.3.7.2, Amendment to Approved Applications, Plans and Permits, below, may be approved by the Manager, using the same review process and criteria applicable to Administrative Adjustments stated in Section 12.4.5 of this Code.
2. The applicable standards for review of such change, modification, removal, or release of an approved application, plan, or permit are those standards in effect at the time a final decision is made on the change, unless otherwise expressly allowed by a duly adopted ordinance of the City Council.



### 12.3.7.2 Amendments to Approved Applications, Plans, and Permits

This Section 12.3.7.2 shall not apply to amendments to LDFs, IMPs, or GDPs. See Sections 12.4.12, Large Development Review, and 12.4.14, Infrastructure Master Plan.

#### A. Procedure and Applicable Rules for Amendments

##### 1. Same Rules and Process Apply as if New Application

An "amendment" to an approved application, plan, or permit shall be reviewed according to the same procedures and subject to the same limitations and requirements, including the payment of fees, as if it were a new application, including, where applicable, review at a public hearing before the Planning Board. The applicable standards for review of the amendment are those standards in effect at the time a final decision is made on the amendment, unless otherwise expressly allowed by a duly adopted ordinance of the City Council.

##### 2. General Rule - Entire Land Area and All Owners Must be Included

Except as otherwise allowed in this Section or this Code, each application for amendment shall include the entire land area of the original approved application, plan, or permit, and shall be initiated by all the owner(s) or agent of the owner(s) of the property to which the amendment applies.

##### 3. Amendments to Approved Site Development Plans - Exception Allowed

###### a. Applicability of Exception

- i. The exception stated in this subsection 12.3.7.2.A.3 shall apply to site development plans previously approved under this Denver Zoning Code and to site development plans previously approved under Former Chapter 59 that are applicable to land zoned and mapped under the Denver Zoning Code.
- ii. Site development plans under Former Chapter 59 include development plans and site plans approved according to Former Chapter 59, Article VIII - Special Zone Lot Plans for Planned Building Groups. The phrase "site development plan" in this Section shall include all types eligible for the exception stated herein.

###### b. Exception to General Rule - Review Process

Contrary to the standards or limitations stated in this Section 12.3.7.2.A and in Former Chapter 59, the Development Review Committee (DRC) may allow an application for an amendment to a previously approved site development plan that is not initiated by all the owners of the property to which the original approved plan applies. In addition, the DRC may allow an application for an amendment to a previously established Zone Lot located within the boundaries of a previously approved site development plan, where the Zone Lot amendment is not initiated by all the owners of the affected Zone Lot(s) and provided the affected Zone Lot(s) does not contain a single unit or two unit Dwelling use. The DRC may approve such exceptions only if the following conditions and criteria are met:

- i. The applicant for the amendment participates in a mandatory Pre-Application Meeting review step, according to Section 12.4.3.3.B. of this Code, before submitting an application to amend the previously approved site development plan and/or Zone Lot.
  - a) As authorized by Section 12.3.3.3.C of this Code, in requiring additional information necessary to make its decision on the exception, the DRC may include analysis of the potential impacts on infrastructure construction, operations, or maintenance referenced or contained in a separate document, report, or plan that supported or justified the approval of the original plan.

- b) **For example**, the DRC may require the applicant to analyze the amendment's impact on a Transportation Engineering Plan (TEP) approved by DOTI outside the previously approved site development plan but a condition precedent to DOTI's approval of the original plan.
- c) **For example**, the DRC may require the applicant to analyze the amendment's impact on a Development Agreement executed and recorded outside the previously approved site development plan but a condition of the DRC's approval of the original plan.
- i. No later than 30 days after the Pre-Application Meeting is held but before the DRC makes a final decision on whether to allow the exception, Community Planning and Development shall cause the applicant to send written (mailed) informational notice to all owners of real property located within the boundaries of the originally approved site development plan and/or Zone Lot area. The contents of the notice shall comply with the provisions stated in Section 12.3.4.5.A.4, General Rules [for Informational Public Notice], and shall give direction for submitting comments to Community Planning and Development within 30 days from the date of mailing.
- ii. The DRC, with advice from other affected city or public agencies or departments, will decide whether to approve or deny the exception based on evidence presented, comments from non-participating owners, and applying the following review criteria:
  - a) No material adverse impacts from the proposed amendment will result to non-participating owners subject to the previously approved plan or Zone Lot approval, or to other affected properties or neighborhoods, or substantial mitigation of such material adverse impacts will be included in the amendment application; and
  - b) Commitments made in the original approved plan, including all conditions of approval, to provide public benefits, including dedications, construction of infrastructure including parks and open space, or affordable housing, will be fulfilled if the amendment is approved.
- iii. Within 15 days after the DRC makes a final decision to approve an application for an exception, Community Planning and Development shall cause the applicant to provide written (mailed) informational notice about the approving decision and right to timely appeal to be sent to all owners of real property located within the boundaries of the originally approved site development plan area. The effective date of the DRC's final decision shall be the date of this mailing.

#### 4. SDP Amendments Must be Recorded

The Manager shall record all amendments to a site development plan approved according to this Section in the records of the Denver County Clerk and Recorder's Office.

### B. Amendments to Approved Regulating Plans, Site Development Plans and Zoning Permits

1. All changes to all or some of the provisions of an approved regulating plan, site development plan or zoning permit, including those changes to a site development plan in a PUD District (but excluding a PUD District Plan amendment which requires City Council approval), which do not qualify as a "modification" under Section 12.3.7.1 above, shall be considered amendments subject to this Section 12.3.7.2.

2. In addition, any of the following changes to an approved regulating plan, site development plan or zoning permit, including but not limited to a site development plan in a PUD District (but excluding a PUD District Plan amendment which requires City Council approval), shall be considered amendments subject to this Section 12.3.7.2:
  - a. An increase in the maximum height of any building by more than 5 feet or 5 percent, whichever is less, but not including allowed height exceptions or incentives, and excepting Accessory Dwelling Units as provided in Section 12.3.7.1.A.2;
  - b. An increase in the floor area ratio (FAR) or Gross Floor Area (GFA), by greater than 10 percent as calculated on a total project basis, except when the increase is caused by the addition of permitted Accessory Dwelling Units;
  - c. A change to the permitted uses or mix of primary uses if the proposed primary uses are more intensive than the approved primary uses, as determined by the Zoning Administrator according to the criteria in Section 12.4.6 (Code Interpretations and Determination of Unlisted Uses), excepting Accessory Dwelling Units as provided in Section 12.3.7.1.A.2;
  - d. A change to the location of permitted primary land uses that would substantially change the development's character or impacts on surrounding property, as determined by the Zoning Administrator, excepting Accessory Dwelling Units as provided in Section 12.3.7.1.A.2;
  - e. Changing the vehicle access from and through public rights-of-way; provided, however, that curb cut locations may shift unless specifically established by the approved plan or permit, excepting Accessory Dwelling Units as provided in Section 12.3.7.1.A.2;
  - f. Changing or negating a condition of approval, except where the condition of approval relates only to provision of a minimum amount of vehicle parking spaces; or
  - g. Modifying any other element of an approved application, plan, or permit, including but not limited to architectural concepts, building elevations, facade treatments and exterior building materials, on- and off-site traffic circulation or the overall design of parking areas, on-site drainage, landscaping, or other existing improvements that would substantially change its character or impacts on surrounding property, as determined by the Manager.

## **SECTION 12.3.8 WITHDRAWAL OF RECORDED SITE DEVELOPMENT PLANS AND GENERAL DEVELOPMENT PLANS**

- 12.3.8.1 This Section 12.3.8 shall not apply to a Large Development Framework. See Section 12.4.12, Large Development Review.
- 12.3.8.2 Pursuant to the same procedure and subject to the same limitations and requirements by which such Site Development Plans, Infrastructure Master Plans (IMPs), or General Development Plans (GDPs) were approved and recorded, all Site Development Plans, IMPs, and GDPs recorded under this Code may be withdrawn, either partially or completely, if all land and structures remaining under such site development plans can be made to comply with all regulations established by this Code. Upon approval of an application to withdraw, the Manager shall record in the real property records of the Denver County Clerk and Recorder an appropriate certificate of such withdrawal.

## DIVISION 12.4 ZONING APPLICATION AND REVIEW PROCEDURES

Division 12.4 contains the specific procedures and review criteria for land use and development applications required by this Code (collectively referred to as “zoning applications”). Applicants should also refer to Division 12.3, Requirements Common to All Zoning Procedures, for procedural requirements generally applicable to all zoning applications, including provisions governing pre-application meetings, application submittals, public notice, and vested rights.

### SECTION 12.4.1 ZONING PERMIT REVIEW

#### 12.4.1.1 Purpose

The purpose of the zoning permit review process is to ensure compliance with the standards and provisions of this Code, while encouraging quality development in Denver reflective of the goals, policies, and strategies found in the Comprehensive Plan.

#### 12.4.1.2 Applicability

##### A. Uses

A zoning permit is required prior to the following:

1. Establishment of a Primary Use.
2. Change of a Primary Use.
3. The establishment of an Accessory Use, or the change of Accessory Use, but only when a zoning permit is required in the Use ~~and Parking~~ Tables found in Articles 3-9.
4. The establishment of a Temporary Use of any structure or land, but only when a zoning permit is required in the Use ~~and Parking~~ Tables found in Articles 3-9.
5. Changes in the total Gross Floor Area (“GFA”) of a use, including increases in the GFA of a use ~~that increase a parking requirement or~~ that is subject to a maximum area limit in this Code (e.g., an Accessory Dwelling Unit use or garage parking use accessory to a Single Unit Dwelling use).

##### B. Structures

#### 1. General Rule: Zoning Permit Required

Unless otherwise specifically excepted, a zoning permit is required prior to construction of a new structure, changes to an existing structure, changes in the gross floor area of a structure, and any development that includes a request for an administrative adjustment or variance.

#### 2. Exceptions in All Zone Districts

A zoning permit is not required for the following types of development, unless the development includes a request for an administrative adjustment or variance, or is listed in Section 12.4.1.2.A.3, Exceptions Do Not Apply to Historic Structures and Districts:

- a. Structures or portions of structures that are 12 inches or less in height, as measured from Finished Grade at the lowest point of the structure, except that a zoning permit is required for construction or changes in the construction of in-ground swimming pools, spas, and hot tubs. *See also* Section 12.4.1.2.D. below, which states when development related to an Off-Street Parking Area, including new vehicle driveways, requires a zoning permit.
- b. Changes to the interior or exterior of an existing structure when neither of the following apply:
  - i. The structure is not located within the boundaries of any area subject to Urban Design Standards and Guidelines; or

### 12.4.2.2 Applicability

Zoning permit review with informational notice is required for the following types of development:

- A. Establishment, expansion or enlargement of a primary, accessory, or temporary use permitted subject to informational notice, as indicated by the designation “ZPIN” (Zoning Permit with Informational Notice) in the applicable Use ~~and Parking~~ Tables found in Articles 3 through 9 of this Code.
- B. Establishment, expansion or enlargement of a primary, accessory, or temporary use permitted in a zone district under Articles 3 through 9 or under any other provision in this Code, where such provision explicitly requires zoning permit review with informational notice and approval prior to establishment of the use.

### 12.4.2.3 Prohibitions and Requirements Prior to Zoning Permit Issuance

#### A. Prohibitions on Activities Prior to Zoning Permit

No development shall occur on property subject to these requirements for zoning permit review until a zoning permit has been approved, unless the Zoning Administrator allows an exception in writing.

#### B. Landmark Preservation Approvals

When the subject Zone Lot contains a structure for preservation designated under D.R.M.C., Chapter 30 (Landmark Preservation) or is located in a district for preservation designated under D.R.M.C., Chapter 30 (Landmark Preservation), no zoning permit shall be approved until a required certificate of appropriateness is issued.

#### C. Payment of Gateway Regional Systems Development Fee

No zoning permit for an applicable Zone Lot, except a zoning permit only for a sign or fence and wall, shall be issued until the regional systems development fee established by the Gateway Regional Metropolitan District on land within the Gateway Regional Metropolitan District has been paid for the subject Zone Lot.

#### D. Denver International Airport (DIA) Review of Uses and Development in the DIA Influence Area Overlay District (AIO)

No zoning permit shall be issued for any use, development, or structure in the DIA Influence Area Overlay District until the Manager of Aviation, or designee, has found that the proposed use, development, or structure complies with the DIA Influence Area Overlay District standards in Article 9 of this Code. The Manager of Aviation shall comment within 14 days from the referral of the complete application. Non-response by the Manager of Aviation within the 14-day time period, or any extension agreed to by the Zoning Administrator, shall be deemed a recommendation of approval.

### 12.4.2.4 Review Process

#### A. Initiation

The owner[s] of the subject property or the owner’s or owners’ authorized agent may initiate an application for zoning permit review with informational notice.

#### B. Pre-Application Meeting

A pre-application meeting is optional before submittal of an application for zoning permit review with informational notice. See Section 12.3.2, Pre-Application Meeting/ Concept Plan Review.

#### C. Application and Fees

##### 1. Submittal in Writing

All applications for zoning permit review with informational notice shall be filed in writing with Community Planning and Development. The applicant shall pay all required fees

priorities or standards in conflict, that the waiver or adjustment of the zoning Standard(s) at issue would reasonably result in greater public benefit(s) without permanent or substantial impairment to the reasonable use and enjoyment or development of adjacent property.

**H. Administrative Adjustments to Certain Standards by Applicable Building Form**

**1. Applicability**

The Zoning Administrator may grant administrative adjustments to the zoning standards shown in the following tables in subsection H.3 below.

**2. Extent of Adjustment Allowed**

- a. The center columns in Tables 12.4.5.2.H.3-1 and -2 below state the extent of administrative adjustments allowed for the standard listed in the corresponding table row.
- b. For adjustments to a minimum setback zoning standard, the Zoning Administrator may grant an adjustment that either provides relief from the required minimum setback distance (e.g., reduce a 20-foot Primary Street Setback to a new 10-foot setback) or allows only a limited encroachment into the required setback distance (allow only a specified portion of the building to encroach 10 feet into a required 20-foot Primary Street Setback). The Zoning Administrator's decision shall consider which form of relief is the minimum necessary to address the justifying circumstance.

**3. Review Criteria**

The last columns in the following Tables 12.4.5.2.H.3-1 and -2 state the applicable review criteria and/or refer to the general review criteria in Section 12.4.5.4 that the Zoning Administrator shall apply to determine whether there are justifying circumstances supporting approval of the administrative adjustment.

TABLE 12.4.5.2.H.3-1 ADMINISTRATIVE ADJUSTMENTS AVAILABLE TO ZONE LOTS WITH THE FOLLOWING PRIMARY BUILDING FORMS: SUBURBAN HOUSE, URBAN HOUSE, DUPLEX, TANDEM HOUSE AND ANY ASSOCIATED DETACHED ACCESSORY STRUCTURE BUILDING FORMS		
ZONING STANDARD	EXTENT OF ADJUSTMENT ALLOWED	APPLICABLE REVIEW CRITERIA
<b>HEIGHT AND BULK FORM STANDARDS</b>		
<ul style="list-style-type: none"> <li>• Maximum height (in stories or feet)</li> <li>• Bulk Plane Dimensions</li> </ul>	No limit, except: <ul style="list-style-type: none"> <li>• In all cases, a height adjustment to a Detached Accessory Dwelling Unit building form shall not result in more than 2 stories; and</li> <li>• The subject building and its elements shall be no taller in feet than a similar building form located within the "existing neighborhood" as defined in Section 12.4.5.4.A.3</li> </ul>	Neighborhood Compatibility, Section 12.4.5.4.A
	No limit, except: <ul style="list-style-type: none"> <li>• In all cases, a height adjustment to a Detached Accessory Dwelling Unit building form shall not result in more than 2 stories</li> </ul>	Unusual Physical Conditions or Circumstances, Section 12.4.5.4.B or Affordable Housing, Section 12.4.5.4.C
<b>SITING FORM STANDARDS</b>		

<b>TABLE 12.4.5.2.H.3-1 ADMINISTRATIVE ADJUSTMENTS AVAILABLE TO ZONE LOTS WITH THE FOLLOWING PRIMARY BUILDING FORMS: SUBURBAN HOUSE, URBAN HOUSE, DUPLEX, TANDEM HOUSE AND ANY ASSOCIATED DETACHED ACCESSORY STRUCTURE BUILDING FORMS</b>		
<b>ZONING STANDARD</b>	<b>EXTENT OF ADJUSTMENT ALLOWED</b>	<b>APPLICABLE REVIEW CRITERIA</b>
Determination of Primary Street Zone Lot Line(s) on Corner Lots of Oblong Blocks or Square Blocks	The Zoning Administrator may designate either or both Zone Lot Lines parallel to the intersecting streets as a Primary Street Zone Lot Line	Neighborhood Compatibility, Section 12.4.5.4.A
Minimum Zone Lot Width	10%	Neighborhood Compatibility, Section 12.4.5.4.A Unusual Physical Conditions or Circumstances, Section 12.4.5.4.B or Affordable Housing, Section 12.4.5.4.C
Minimum Zone Lot Depth	15%	Neighborhood Compatibility, Section 12.4.5.4.A Unusual Physical Conditions or Circumstances, Section 12.4.5.4.B or Affordable Housing, Section 12.4.5.4.C
Minimum Zone Lot Area	15%	Neighborhood Compatibility, Section 12.4.5.4.A Unusual Physical Conditions or Circumstances, Section 12.4.5.4.B or Affordable Housing, Section 12.4.5.4.C
Primary Street Setback	No limit	Neighborhood Compatibility, Section 12.4.5.4.A
	20%	Unusual Physical Conditions or Circumstances, Section 12.4.5.4.B or Affordable Housing, Section 12.4.5.4.C
Side Interior Setback requirements on Zone Lots greater than 30 feet wide up to and including 40 feet wide	No limit, provided the adjustment results in a Side Interior Setback no less than 3 feet	Neighborhood Compatibility, Section 12.4.5.4.A
Setback requirements, all others	25%	Neighborhood Compatibility, Section 12.4.5.4.A Unusual Physical Conditions or Circumstances, Section 12.4.5.4.B or Affordable Housing, Section 12.4.5.4.C
Detached accessory structure location relative to Primary Street-facing façade	No limit	Neighborhood Compatibility, Section 12.4.5.4.A
	50%	Neighborhood Compatibility, Section 12.4.5.4.A Unusual Physical Conditions or Circumstances, Section 12.4.5.4.B or Affordable Housing, Section 12.4.5.4.C
Maximum building coverage	5% (The % adjustment approved is added to the maximum building coverage %; for example, if the standard maximum is 37.5% coverage, a 3% adjustment would permit a maximum 40.5% building coverage)	Unusual Physical Conditions or Circumstances, Section 12.4.5.4.B or Affordable Housing, Section 12.4.5.4.C
<b>DESIGN ELEMENT FORM STANDARDS</b>		

TABLE 12.4.5.2.H.3-1 ADMINISTRATIVE ADJUSTMENTS AVAILABLE TO ZONE LOTS WITH THE FOLLOWING PRIMARY BUILDING FORMS: SUBURBAN HOUSE, URBAN HOUSE, DUPLEX, TANDEM HOUSE AND ANY ASSOCIATED DETACHED ACCESSORY STRUCTURE BUILDING FORMS		
ZONING STANDARD	EXTENT OF ADJUSTMENT ALLOWED	APPLICABLE REVIEW CRITERIA
Attached Garage - location relative to Primary Street-facing façade	No limit	Neighborhood Compatibility, Section 12.4.5.4.A Unusual Physical Conditions or Circumstances, Section 12.4.5.4.B or Affordable Housing, Section 12.4.5.4.C
<b>OTHER ZONING STANDARDS</b>		
<del>Required Amount of Parking in the Historic Structure Use Overlay District (UO-3) Only</del>	<ul style="list-style-type: none"> <li><del>Office/art studio use in a Historic Structure: No limit</del></li> <li><del>Bed and breakfast use in a Historic Structure: 20%</del></li> </ul>	<del>Unusual Physical Conditions or Circumstances, Section 12.4.5.4.B See also Section 9.4.4.8</del>
<del>Required Parking for Limited Nonresidential Uses Permitted in Existing Business Structures</del>	No limit	<del>Unusual Physical Conditions or Circumstances, Section 12.4.5.4.B See also Section 11.4.6</del>
Garage and Carport - Minimum Vehicle Maneuvering Area	Up to 3' reduction, provided the adjustment results in a maneuvering area of no less than 18 feet	Unusual Physical Conditions or Circumstances, Section 12.4.5.4.B
Minimum Landscaping Standards	No limit	Adjustment permitted when Zoning Administrator finds the adjustment meets the criteria for one of the following: <ul style="list-style-type: none"> <li>10.5.4.1.B.2 for Physical Limitations;</li> <li>10.5.4.1.B.3. for Excessive Improvement Costs;</li> <li>10.5.4.1.B.4 for Preservation of Existing Trees; or</li> <li>Unusual Physical Conditions or Circumstances, Section 12.4.5.4.B</li> </ul>

TABLE 12.4.5.2.H.3-2 ADMINISTRATIVE ADJUSTMENTS AVAILABLE TO ZONE LOTS WITH BUILDING FORMS OTHER THAN THOSE LISTED IN TABLE 12.4.5.2.H.3-1		
ZONING STANDARD	EXTENT OF ADJUSTMENT ALLOWED	APPLICABLE REVIEW CRITERIA
<b>SITING FORM STANDARDS</b>		
Determination of Primary Street Zone Lot Line(s) on Corner Lots of Oblong Blocks or Square Blocks	Zoning Administrator may designate either or both Zone Lot Lines parallel to the intersecting streets as a Primary Street Zone Lot Line	Neighborhood Compatibility, Section 12.4.5.4.A
Minimum Zone Lot Width	No limit	Neighborhood Compatibility, Section 12.4.5.4.A
	15%	Unusual Physical Conditions or Circumstances, Section 12.4.5.4.B or Affordable Housing, Section 12.4.5.4.C
Primary Street Setback, except in the C-CCN Zone District	20%	Neighborhood Compatibility, Section 12.4.5.4.A Unusual Physical Conditions or Circumstances, Section 12.4.5.4.B or Affordable Housing, Section 12.4.5.4.C



TABLE 12.4.5.2.H.3-2 ADMINISTRATIVE ADJUSTMENTS AVAILABLE TO ZONE LOTS WITH BUILDING FORMS OTHER THAN THOSE LISTED IN TABLE 12.4.5.2.H.3-1		
ZONING STANDARD	EXTENT OF ADJUSTMENT ALLOWED	APPLICABLE REVIEW CRITERIA
Setback requirements, all others	20%	Neighborhood Compatibility, Section 12.4.5.4.A Unusual Physical Conditions or Circumstances, Section 12.4.5.4.B or Affordable Housing, Section 12.4.5.4.C
Build-to requirement -- Adjustment applies only to the min/max range of required build-to (e.g., an adjustment is permitted to the 0' to 5' range, but not to the minimum 70% build-to portion of the standard)	Not to exceed a min/max build-to range of 0' to 15'	Neighborhood Compatibility, Section 12.4.5.4.A Unusual Physical Conditions or Circumstances, Section 12.4.5.4.B or Affordable Housing, Section 12.4.5.4.C
Build-to requirement to accommodate required water quality and/or detention/retention facilities	Adjustment to allow a build-to alternative (e.g., a garden wall) to count up to 40% (e.g., a standard states up to 25% of the 70% build-to may be met by a garden wall - with adjustment, 25% may be increased to 40%)	Neighborhood Compatibility, Section 12.4.5.4.A Unusual Physical Conditions or Circumstances, Section 12.4.5.4.B or Affordable Housing, Section 12.4.5.4.C
Build-to requirement - Adjustment applies only to zone lots that are 80' wide or less	No limit, provided the build-to adjustment is necessary to provide the required minimum internal drive dimension for public street access required by the City.	Neighborhood Compatibility, Section 12.4.5.4.A Unusual Physical Conditions or Circumstances, Section 12.4.5.4.B or Affordable Housing, Section 12.4.5.4.C
Build-to requirement - Adjustment applies only to sites with gas station uses existing on June 25, 2010	40%	Unusual Physical Conditions or Circumstances, Section 12.4.5.4.B
Siting of outdoor trash storage areas for multi-unit and nonresidential development in MS Zone Districts	Setback reduction allowed to no less than 10'	Neighborhood Compatibility, Section 12.4.5.4.A Unusual Physical Conditions or Circumstances, Section 12.4.5.4.B or Affordable Housing, Section 12.4.5.4.C The Zoning Administrator must also find that the adjustment: (1) will have no substantial adverse impacts on the abutting Residential Zone District or Residential Use; and (2) the adjustment is consistent with the intent and purpose of the Main Street zone district.
DESIGN ELEMENT FORM STANDARDS		
All Building Configuration Form Standards	15%	Neighborhood Compatibility, Section 12.4.5.4.A Unusual Physical Conditions or Circumstances, Section 12.4.5.4.B or
	No limit	Affordable Housing, Section 12.4.5.4.C
OTHER ZONING STANDARDS		
Required Amount of Parking in the Historic Structure Use Overlay District (UO-3) Only	<ul style="list-style-type: none"> <li>• Office/art studio use in a Historic Structure: no limit</li> <li>• Bed and breakfast use in a Historic Structure: 20%</li> </ul>	<ul style="list-style-type: none"> <li>• Unusual Physical Conditions or Circumstances, Section 12.4.5.4.B</li> <li>• See also Section 9.4.4.8</li> </ul>

TABLE 12.4.5.2.H.3-2 ADMINISTRATIVE ADJUSTMENTS AVAILABLE TO ZONE LOTS WITH BUILDING FORMS OTHER THAN THOSE LISTED IN TABLE 12.4.5.2.H.3-1		
ZONING STANDARD	EXTENT OF ADJUSTMENT ALLOWED	APPLICABLE REVIEW CRITERIA
Required <a href="#">Bicycle</a> Parking	No limit	Adjustment permitted when Zoning Administrator finds the adjustment meets the criteria for one of the following: <ul style="list-style-type: none"> <li>Unusual Physical Conditions or Circumstances, Section 12.4.5.4.B, and the Zoning Administrator finds the adjustment is necessary to allow reasonable siting of required electric vehicle charging equipment;</li> <li><del>Affordable Housing, Section 12.4.5.4.C</del></li> <li><del>Sections 10.4.2.2 or 10.4.2.3 for Improvement to an Existing Off-Street Parking Area; or</del></li> <li>Section 10.5.4.1.B.4 for Preservation of Existing Trees.</li> </ul>
Minimum Width of Parking Aisles or Internal Drives in Off-Street Parking Areas	No limit	Must meet Unusual Physical Conditions or Circumstances, Section 12.4.5.4.B, and Zoning Administrator finds the adjustment is necessary to provide safe vehicle access.
Minimum Landscaping Standards	No limit	Adjustment permitted when Zoning Administrator finds the adjustment meets the criteria for one of the following: <ul style="list-style-type: none"> <li>10.5.4.1.B.2 for Physical Limitations</li> <li>10.5.4.1.B.3. for Excessive Improvement Costs;</li> <li>10.5.4.1.B.4 for Preservation of Existing Trees; or</li> <li>Unusual Physical Conditions or Circumstances, Section 12.4.5.4.B</li> </ul>

### 12.4.5.3 Review Process

#### A. Initiation

The owner of the subject property, the owner’s authorized agent, a public utility, or the Manager of Community Planning and Development may initiate an application for an administrative adjustment.

#### B. Pre-Application Meeting

A pre-application meeting is mandatory before submittal of an application for administrative adjustment. See Section 12.3.2, Pre-Application Meeting/Concept Plan Review.

#### C. Application and Fees

All applications for administrative adjustments shall be filed in writing with Community Planning and Development. The applicant shall pay all required fees at the same time the application is submitted. See Section 12.3.3, Submission of Applications.

#### D. Timing of Administrative Adjustment Requests

##### 1. Adjustments Authorized Prior to Application Submittal

- a. The Zoning Administrator may approve administrative adjustments in response to a written request made prior to the submittal of an application for review of a Site Development Plan, zoning permit, or Zone Lot Amendment application. The Zoning Administrator may approve the requested adjustment if the Zoning Administrator finds the request is necessary to enable the applicant to submit a complete development application for review.
  - i. **For example**, the Zoning Administrator may approve a request to adjust the Primary Street Setback before formal zoning permit application review of the construction of a new single unit dwelling, because a final decision on the

#### 12.4.5.4 Review Criteria

Except for the administrative adjustments allowed in Section 12.4.5.2.A through G above, the Zoning Administrator may approve an administrative adjustment only upon finding that the adjustment complies with at least one of the following review criteria supporting justifying circumstances:

##### A. Neighborhood Compatibility

The Zoning Administrator may grant an administrative adjustment when:

1. The property could be reasonably developed in conformity with the provisions of this Code, but the proposed adjustment will result in a building form that is more compatible with similar building forms in the existing neighborhood in which the subject property is located than a project that complies with this Code in terms of:
  - a. Building height,
  - b. Siting, and
  - c. Design elements
2. A proposed adjustment to Zone Lot area or Zone Lot dimensions will result in a Zone Lot that is as or more compatible with the pattern of Zone Lots in the existing neighborhood in which the subject property is located.
3. For purposes of making a determination of whether the subject property, with the proposed adjustment, would be more compatible with the existing neighborhood, the following rules shall apply:
  - a. "Existing Neighborhood" shall mean any Zone Lot or similar building form on a Zone Lot that is located on the same Face Block, opposite Face Block, or adjacent Face Block to the subject property. The Existing Neighborhood may extend beyond the aforementioned limits if the Zoning Administrator deems it reasonable and necessary to make a determination of compatibility with the most relevant existing neighborhood.
  - b. While a finding of "more compatible" does not have to adhere to a strict mathematical formula, such as an exact finding that 51% or more of the existing neighborhood's Zone Lots are dimensioned or contain building form elements similar to the requested adjustment, the Zoning Administrator shall consider the following in making a final decision based on neighborhood compatibility:
    - i. Whether the existing pattern of the Zone Lots in the identified existing neighborhood that have Zone Lot dimensions or contain building form elements substantially similar to the subject property supports a finding of neighborhood compatibility; and/or
    - ii. Whether the grant of the administrative adjustment would establish a precedent in the Existing Neighborhood for similar future requests, which would adversely impact the existing character and built context in the identified Existing Neighborhood.

##### B. Unusual Physical Conditions or Circumstances

The Zoning Administrator may grant an administrative adjustment when the adjustment is necessary to provide reasonable relief from unusual physical conditions or circumstances and the Applicant shows that all the following criteria (1 through 6) are met:

1. There are unusual physical circumstances or conditions, including but not limited to:
  - a. Irregularity, narrowness, or shallowness of the lot;
  - b. Exceptional topographical or other physical conditions peculiar to the affected property;

- c. The circumstances or conditions relate to drainage conditions and challenges, not including location in a designated floodplain;
  - d. Presence of Established Trees that would otherwise be removed with the strict application of standards; or
  - e. Unusual physical circumstances or conditions arising from a Conforming, Compliant, or Nonconforming Structure existing on the subject property or on an abutting Zone Lot.
2. The circumstances or conditions do not exist throughout the neighborhood or zone district in which the property is located, except for those adjustments based on any one of the following:
    - a. Those based on drainage conditions, as described in subsection B.1.c above, or
    - b. Those based on Nonconforming or Compliant Structures, as described in subsection B.1.e. above, or
    - c. Those based on the reuse of an existing structure when the request is to adjust minimum [bicycle](#) parking standards, as described in Table 12.4.5.2.H.3-2 above.
  3. The unusual physical circumstances or conditions have not been created by the Applicant.
  4. Would not substantially or permanently impair the reasonable use and enjoyment or development of the subject property or adjacent property.
  5. The unusual physical condition or circumstance causes the need for the adjustment.
  6. The proposed design addresses any concerns raised by the Zoning Administrator or other city agencies in their review of the request.

**C. Affordable Housing**

The Zoning Administrator may grant an administrative adjustment when:

1. The proposed development or design would result in more Income Restricted Units than would be created without the administrative adjustment;
2. The adjustment to the subject standard cannot be accomplished through any specific incentives available in this Code or in mandates for the provision of Income Restricted Units under other City laws;
3. The purpose of the adjusted standard will still be achieved or substantially advanced if the adjustment is approved;
4. Would not substantially or permanently impair the reasonable use and enjoyment or development of the subject property or adjacent property;
5. The proposed design addresses any concerns raised by the Zoning Administrator or other city agencies in their review of the request.

**D. Other Required Findings**

For administrative adjustments to certain standards by building form authorized by Section 12.4.5.2.H, and where the right-most column of Tables 12.4.5.2.H.3-1 and 12.4.5.2.H.3-2 refer to applicable review criteria that are not specifically stated in this Section 12.4.5.4, the Zoning Administrator shall apply those particular review criteria stated in the Tables.

**12.4.5.5 Effect of Approval - Expiration**

- A. Administrative adjustments approved under Section 12.4.5.3.D.1., Adjustments Authorized Prior to Application Submittal, shall expire 180 days after the approval date unless the applicant submits a complete application for a Site Development Plan, zoning permit, or zone lot amendment necessary to execute the approved administrative adjustment. A failure to obtain

#### 4. Form of Determination

The Zoning Administrator shall provide the Code Interpretation or Determinations of Unlisted Uses to the applicant in writing. Such interpretation or determination shall also be kept in the files of the Zoning Administrator.

#### F. General Rules of Interpretation

When making a Code Interpretation or Determination of Unlisted Uses, the Zoning Administrator shall employ the following general rules, as applicable:

1. Employ the definitions contained in Article 13 to determine the meaning of words and phrases, or if not defined in Article 13, apply the plain meanings of all other words and phrases. When not defined in Article 13, if a word or phrase is subject to differing interpretations, then the Zoning Administrator shall apply the meaning assigned first by the D.R.M.C., as applicable, and then by a dictionary in general use.
2. Employ the definitions of land uses in Article 11 to determine the appropriate use classification, use category and/or specific use type in which to classify an unlisted use.
3. Where more than one interpretation of required procedures is possible, the Zoning Administrator shall select the interpretation of procedures that requires the lesser time and expense to the applicant consistent with the provisions of the charter, the D.R.M.C., and this Code.
4. Where more than one interpretation of required provisions or procedures is possible, the Zoning Administrator shall choose that interpretation that best implements the Comprehensive Plan and/or this Code in a manner consistent with applicable law.
5. In the case of any conflict between the General Rules for Interpretation in this Section 12.4.6.3.F and the Rules of Interpretation found in Division 13.2 of this Code, the General Rules of Code Interpretation in this Section 12.4.6.3.F shall apply.

#### 12.4.6.4 Review Criteria

##### A. General Review Criteria for All Code Interpretations and Determinations of Unlisted Uses

The Zoning Administrator shall make Code Interpretations and Determinations of Unlisted Uses only upon finding that the interpretation or determination is:

1. Consistent with the intent of this Code; and
2. Consistent with the intent of the subject Neighborhood Context and zone district(s), and with the intent of any specific Code provision(s) at issue.

##### B. Additional Review Criteria for Unlisted Use Determinations

In addition to applying the general review criteria stated in Section 12.4.6.4.A, the Zoning Administrator shall apply the following criteria for a Determination of Unlisted Use:

1. The proposed use has a character and impact that are similar in nature, function, and duration to the other uses permitted in the zone district(s). In making such finding, the Zoning Administrator shall assess all relevant characteristics of the proposed use, including but not limited to the following, as applicable:
  - a. The typical volume and type of sales (retail or wholesale); size and type of items sold; and nature of inventory on the premises;
  - b. Any processing done on the premises, including assembly, manufacturing, warehousing, shipping, distribution; and any dangerous, hazardous, toxic, or explosive materials used in the processing;

- c. The nature and location of storage and outdoor display of merchandise; whether storage is enclosed, open, inside, or outside the principal building; and predominant types of items stored (such as business vehicles, work-in-process, inventory, and merchandise, construction materials, scrap and junk, and raw materials including liquids and powders hazardous or not);
- d. The type, size, and typical massing of buildings and structures associated with the unlisted use;
- e. Transportation requirements, including the modal split for people and freight, by volume type and characteristics of traffic generation to and from the site; trip purposes and whether trip purposes can be shared by other uses on the site;
- f. ~~Parking requirements, turnover and generation, ratio of the number of spaces required per unit area or activity, and the potential for shared parking with other uses;~~
- g. The amount and nature of any external effects generated on the premises, including but not limited to noise, smoke, odor, glare, vibration, radiation and fumes;
- h. Any special public utility requirements for serving the proposed use, including but not limited to water supply, waste water, pre-treatment of wastes and emissions required or recommended, and any significant power structures and communications towers or facilities; and
- i. The type and extent of impacts on adjacent properties created by the proposed use in comparison to impacts from other uses permitted in the zone district.

## SECTION 12.4.7 VARIANCE

### 12.4.7.1 Purpose

The Board of Adjustment may authorize variances from the terms of this Code, subject to terms and conditions fixed by the Board of Adjustment, as will not be contrary to the public interest and where owing to justifying circumstances, deviation from literal enforcement or application of this Code is reasonable.

### 12.4.7.2 Related Procedure

Under certain circumstances, modifications of this Code's standards may be permitted according to the administrative adjustment procedure in Section 12.4.5, without resorting to this variance procedure.

### 12.4.7.3 Applicability and Limitations

#### A. Applicability

The Board of Adjustment may approve variances to all of the following, unless expressly prohibited or limited by this Section 12.4.7.3:

1. All Zone Lot, Building Form, and Development standards found in Articles 1 through 10 of this Code, unless otherwise stated that a variance is not allowed;
2. All use limitations found in Article 11 of this Code, unless otherwise stated that a variance is not allowed and
3. The following provisions in Article 12 of this Code:
  - a. The development standards applicable to development of a Carriage Lot stated in Section 12.10.4, Development on Carriage Lots, but not including the zoning permit review procedures and conditions stated in Section 12.10.4.5; and
  - b. Wherever else in Article 12 the Board of Adjustment is expressly authorized to grant variances.

8. A greater total area of signs than that which is permitted under the provisions of Division 10.10, Signs, for the primary use in the zone district in which the primary use is or will be maintained.

**E. Variances for Signs for Religious Assembly Uses**

Notwithstanding the limitations set forth in this subsection 12.4.7.3.D, Limitations on Variances for Signs, the Board of Adjustment shall have the power to grant variances from the provisions of Division 10.10, Signs, for signs that identify Religious Assembly uses when such signs are located on the same Zone Lot as the permitted Religious Assembly use.

**12.4.7.4 Review Process**

**A. Initiation**

The owner of the subject property, the owner's authorized agent, or a public utility may initiate an application for a variance.

**B. Mandatory Pre-Application Meeting**

A pre-application meeting between the Applicant and CPD is mandatory before submittal of an application for a variance to the Board of Adjustment. See Section 12.3.2, Pre-Application Meeting/Concept Plan Review. The Board of Adjustment may request an Applicant to submit evidence that the pre-application meeting was conducted with CPD prior to accepting an application for a variance.

**C. Application and Fees**

All applications for variance shall be filed in writing according to the rules of the Board of Adjustment. The applicant shall pay all required fees at the same time the application is submitted. See Section 12.3.3, Submission of Applications.

**D. Public Hearing and Decision by Board of Adjustment**

1. Following notice and a public hearing according to the rules of the Board of Adjustment, the Board of Adjustment shall approve, approve with conditions, or deny the variance request based on whether the Applicant has demonstrated compliance with the review criteria in both Sections 12.4.7.5 and 12.4.7.6 below, and subject to any limitations in Section 12.4.7.3.
2. The Board may attach any condition to a variance approval necessary to protect the health, safety and welfare of the community and minimize adverse impacts on adjacent properties, including but not limited to a condition changing the location or dimensions of a proposed development directly related to the request for a variance.

**12.4.7.5 Review Criteria - Justifying Circumstances**

The Board of Adjustment may grant a variance only if it finds that there are justifying circumstances whereby the application satisfies the criteria of **any one of Sections 12.4.7.5.A. through F in addition to satisfying the general review criteria in Section 12.4.7.6.**

**A. Unusual Physical Conditions or Circumstances**

The variance is necessary to provide reasonable relief from unusual physical conditions or circumstances and the Applicant shows that all the following criteria are met:

1. There are unusual physical circumstances or conditions, including, without limitation:
  - a. Irregularity, narrowness or shallowness of the lot;
  - b. Exceptional topographical or other physical conditions peculiar to the affected property;
  - c. Circumstances or conditions related to drainage conditions and challenges, not including location in a designated floodplain;

- d. Presence of Established Trees that would otherwise be removed with the strict application of standards; or
  - e. Unusual physical circumstances or conditions arising from a Conforming, Compliant, or Nonconforming Structure existing on the affected property or on an abutting Zone Lot.
2. The circumstances or conditions do not exist throughout the neighborhood or zone district in which the property is located except for those adjustments based on any one of the following:
    - a. Those based on drainage conditions, as described in subsection B.1.c above; or
    - b. Those based on Conforming, Compliant, or Nonconforming Structures, as described in subsection B.1.e. above.; or
    - c. Those based on the reuse of an existing structure when the variance request is to adjust minimum [bicycle](#) parking standards.
  3. The unusual physical circumstances or conditions have not been created by the applicant.
  4. The unusual physical condition or circumstance causes the need for the variance.

#### **B. Neighborhood Compatibility**

1. The property could be reasonably developed in conformity with the provisions of this Code, but the proposed variance will result in a building form that is more compatible with similar building forms in the Existing Neighborhood in which the subject property is located than a project that complies with this Code's Building Form Standards that address:
  - a. Building Height,
  - b. Siting, and
  - c. Design Elements.
2. A proposed variance to Zone Lot area or Zone Lot dimensions will result in a Zone Lot that is as or more compatible with the pattern of Zone Lots in the existing neighborhood in which the subject property is located.
3. For purposes of making a determination of whether the subject property, with the proposed variance, would be more compatible with the Existing Neighborhood, the following rules shall apply:
  - a. "Existing Neighborhood" shall mean any Zone Lot or similar building form on a Zone Lot that is located on the same Face Block, opposite Face Block, or adjacent Face Block to the subject property. The Existing Neighborhood may extend beyond the aforementioned limits if the Board of Adjustment finds the expansion is reasonable and necessary to make a determination of compatibility with the most relevant existing neighborhood.
  - b. While a finding of "more compatible" does not have to adhere to a strict mathematical formula, such as an exact finding that 51% or more of the existing neighborhood's Zone Lots are dimensioned or contain building form elements similar to the requested variance, the Board of Adjustment shall consider the following in making a final decision based on neighborhood compatibility:
    - i. Whether the existing pattern of Zone Lots in the identified existing neighborhood that have Zone Lot dimensions or contain building form elements substantially similar to the subject property that supports a finding of neighborhood compatibility; and/or



## SECTION 12.4.9 ZONING PERMIT WITH SPECIAL EXCEPTION REVIEW

### 12.4.9.1 Applicability

Zoning permit with special exception review is required for the following:

- A. Establishment, expansion or enlargement of any use listed as a “Special Exception” use (“ZPSE”) in the Use ~~and Parking~~ Tables found in Articles 3 through 9.
- B. Establishment, expansion or enlargement of any use where an applicable use limitation in Articles 3 through 9, or in Article 11, Use Limitations and Definitions, or any other provision of this Code, states that Special Exception review under this Section is required.

### 12.4.9.2 Review Process

#### A. Initiation

The owner of the subject property or the owner’s authorized agent may initiate an application for a zoning permit with special exception review.

#### B. Pre-Application Meeting

A pre-application meeting with the Zoning Administrator is mandatory for review of a use qualifying as a zoning permit with special exception review under this Section. See Section 12.3.2, Pre-Application Meeting/ Concept Plan Review. Pre-application meetings for all other special exceptions are optional.

#### C. Application and Fees

##### 1. Submittal in Writing

All applications for zoning permit with special exception review shall be filed in writing with the Zoning Administrator. The applicant shall pay all required fees at the same time the application is submitted. See Section 12.3.3, Submission of Applications.

##### 2. Concurrent Applications

The applicant may submit an application for zoning permit with special exception review concurrent with other applications according to Section 12.3.3.9, Concurrent Applications. In no case, however, shall the City issue a building permit, as applicable, until the Board of Adjustment approves the special exception use and Community Planning and Development issues a zoning permit.

#### D. Public Notice Requirements

Public notice shall be required and provided according to the rules of the Board of Adjustment.

#### E. Review, Referral, and Recommendation by Zoning Administrator

1. The Zoning Administrator shall refer the application to the Board of Adjustment. The Board of Adjustment shall schedule the application for review and final decision at a public hearing, according to the rules of the Board of Adjustment.
2. The Zoning Administrator may refer the application to other affected or interested agencies for review and comment.
3. The Zoning Administrator shall consider the comments from all interested agencies, prepare a written recommendation based on the application's compliance with the review criteria below, and submit a written recommendation to the Board of Adjustment according to the rules of the Board of Adjustment.

#### F. Public Hearing and Final Decision by Board of Adjustment

1. The Board of Adjustment shall provide public notice and hold a public hearing on the proposed special exception according to the rules of the Board of Adjustment. The Board shall consider the recommendation of the Zoning Administrator and any relevant public

2. For the purpose of defining owners and the area of land represented by the owner, land owned by more than one owner shall be divided to the extent of each owner's percentage of ownership interest in determining whether a protest has the required percentage of signatures.
3. The Manager shall determine the adequacy of all protest petition signatures.

**B. Filing of Protests; Time Limitations; Withdrawal**

All protests to an official map amendment and any withdrawal of the protest or specific petition signatures shall be filed with the City Council on or before, and not later than, noon 7 days prior to the date for the public hearing before City Council on the official map amendment. No protests shall be signed until the official map amendment council bill is ordered published by City Council.

**12.4.10.6 Waivers of Rights and Obligations and Approval of Reasonable Conditions**

- A. Whenever an application for an official map amendment, in whole or in part, is based upon a written representation by the applicant(s) that the applicant(s) wishes to waive certain rights or obligations under the proposed district classification, the City Council may adopt such waivers as a part of the ordinance amending the official map if such waivers are approved in writing by the applicant(s).
- B. Whenever public necessity, convenience, general welfare or good zoning practice justify the attachment of reasonable conditions to an official map amendment, the City Council may adopt such conditions as a part of the ordinance amending the official map if such conditions are approved in writing by the applicant(s).
- C. Upon adoption of an ordinance pursuant to subsections A. or B. above, no zoning permits shall be issued except in strict compliance with the approved waivers or conditions. Any person who applies for a permit to alter or erect a structure in such area shall be deemed to have assented to all of these waivers and conditions.
- D. Every official map amendment based, in whole or in part, upon waivers as set forth in subsection A. or conditions as set forth in subsection B. above:
  1. ~~s~~Shall be adopted by ordinance containing an exact description of any such waivers or conditions. Such ordinance may be amended by City Council upon application for an amendment either by the original applicant or by a successor in interest; provided, however, that prior to such amendment, public notice shall be given similar in all respects to the public notice required for an official map amendment;
  2. ~~Shall not include a requirement for a minimum amount of vehicle parking; and~~
  3. ~~Nothing contained in this Section~~s shall not be construed as a requirement that all applications for rezoning must contain waivers or have conditions.
- E. When City Council approves a text amendment to the standards applicable in a zone district (see Section 12.4.11), such text amendment applies equally to all previously approved official map amendments to that zone district, including official map amendments that were based, in whole or in part, upon waivers or conditions.

**12.4.10.7 General Review Criteria Applicable to All Zone Map Amendments**

The City Council may approve an official map amendment if the proposed rezoning complies with all of the following criteria:

**A. Consistency with Adopted Plans**

The proposed official map amendment is consistent with the City's adopted plans.

## DIVISION 12.5 COMPLIANT USES

### SECTION 12.5.1 INTENT

The creation in this Division of the legal status of "compliant use" is intended to provide greater flexibility than the category of "nonconforming uses" in the continuation, expansion or enlargement of existing land uses still permitted in the subject zone district, but which no longer comply with this Code's use limitations.

### SECTION 12.5.2 DEFINITION

See Article 13 for definition of "Use, Compliant," and "Use, Conforming."

### SECTION 12.5.3 EFFECT

#### 12.5.3.1 Right to Continue

Compliant uses are legal uses for all purposes under this Code, and may continue to operate indefinitely.

#### 12.5.3.2 General Allowance and Limitation on Expansion

- A. Provided it continues to comply with all provisions of this Division, any compliant use may continue in operation on the same Zone Lot and on the same floor area in a structure that was occupied by the compliant use on the date the use first became a compliant use.
- B. Except as authorized in this Division 12.5, the Zone Lot or the floor area in a structure devoted to the operation and maintenance of a compliant use shall not be increased if the extent or degree of noncompliance with this Code is increased.
- C. Continuance authorized in this Division shall not be construed to permit an increase in the number of dwelling units, a reduction of the ratio of land area to the number of dwelling units, or a change in any aspect of or the character of the compliant use that increases the amount, extent, or degree of noncompliance. This subsection shall not be construed to prohibit changes in the compliant use that result in a decrease in the amount, extent, or degree of noncompliance (e.g., a reduction in the floor area of the compliant use ~~that results in a decrease in the amount of parking required~~).
- D. A compliant Automobile Services, Light, use containing an Automobile Fueling Station may be modified or relocated on the same Zone Lot or within the floor area of a structure occupied by the compliant use to allow reasonable siting of Electric Vehicle Supply Equipment, provided the change to the compliant use does not result in an increase in the amount, extent or degree of noncompliance and continues to comply with all provisions of this Division. This subsection shall not be construed to permit an increase in the number of automotive fuel pumps.

#### 12.5.3.3 Zoning Administrator Authority to Allow Limited Expansions

##### A. Zoning Administrator Authority in Special Cases Only

1. The Zoning Administrator may authorize, upon application in specific cases, an exception permitting an increase in either or both the Zone Lot area or the floor area in a structure or structures occupied by a compliant use as are necessary and essential to enable the owner of the use to comply with lawful requirements of the federal, state, or municipal governments; or
2. As a result of an act of government through vacation of right-of-way that creates private land area abutting an existing Zone Lot, for that newly created private land, the Zoning Administrator may authorize, upon application in specific cases, an exception permitting the existing compliant use on the existing Zone Lot to expand in Zone Lot area, but not floor area in a structure or structures, onto the newly created private land.

## DIVISION 12.7 NONCONFORMING USES

### SECTION 12.7.1 INTENT

The creation in this Division of the legal status of "nonconforming use" assures that land uses no longer permitted in a zone district are strictly limited in their right to continue, expand, or enlarge. Such nonconforming land uses are presumed to be incompatible with permitted uses in the zone district, typically because the nature or scale of the nonconforming use's operation create adverse impacts on surrounding properties or the character of the surrounding neighborhood context. Accordingly, the provisions in this Division 12.7 encourage nonconforming uses, over time, to terminate or relocate to a zone district where they are permitted.

### SECTION 12.7.2 APPLICABILITY

- 12.7.2.1 Division 12.7 applies to all nonconforming uses. For purposes of this Code, "nonconforming use" means any use which, at the time the use was first permitted or initiated, was lawfully operated, and has since that time been continuously lawfully operated, but which use is not a "conforming use" as defined in this Code and is not a "compliant use" as defined in this Code.
- 12.7.2.2 Nonconforming outdoor general advertising devices (billboards) and other nonconforming signs shall be subject to the nonconforming sign provisions in Division 12.9 of this Article instead of the nonconforming use standards stated in this Division 12.7.

### SECTION 12.7.3 LIMITED CONTINUANCE OF NONCONFORMING USES ALLOWED

#### 12.7.3.1 General Allowance and Limitation on Expansion

- A. Provided it continues to comply with all provisions of this Section, any Nonconforming Use may be continued in operation on the same Zone Lot and on the same floor area in a Structure that was occupied by the Nonconforming Use on the date the use first became a Nonconforming Use.
- B. Except as authorized in Section 12.7.3.3, the Zone Lot or the floor area in a Structure devoted to the operation and maintenance of a Nonconforming Use shall not be increased.
- C. The continuance authorized hereunder shall not be construed to permit an increase in the number of dwelling units, a reduction of the ratio of Zone Lot area to the number of Dwelling Units, or a change in any aspect or the character of the Nonconforming Use that increases the amount, extent, or degree of nonconformity. This subsection shall not be construed to prohibit changes in the Nonconforming Use that result in a decrease in the amount, extent or degree of nonconformity (e.g., a reduction in the floor area of the Nonconforming Use ~~that results in a decrease in the amount of parking required~~).

#### 12.7.3.2 Zoning Administrator Authority to Allow Limited Expansions

##### A. Zoning Administrator Authority in Special Cases Only

1. The Zoning Administrator may authorize, upon application in specific cases, an exception permitting an increase in either or both the Zone Lot area or the floor area in a structure or structures occupied by a nonconforming use as are necessary and essential to enable the owner of the use to comply with lawful requirements of the federal, state, or municipal governments; or
2. As a result of an act of government through vacation of right-of-way that creates private land area abutting an existing Zone Lot, for that newly created private land, the Zoning Administrator may authorize, upon application in specific cases, an exception permitting the existing nonconforming use on the existing Zone Lot to expand in Zone Lot area, but not floor area in a structure or structures, onto the newly created private land.

**3. Duplex**

The Duplex building form may not be used when another building form, such as the Suburban House or Urban House building form, is allowed in the same zone district and the nonconforming Zone Lot's size and/or width is less than what is allowed for the Duplex building form.

**4. Tandem House**

- a. The Tandem House building form is allowed when the Nonconforming Zone Lot's area and/or width is less than the minimum required for any other primary building form allowed in the subject zone district, except as further limited herein.
- b. The Tandem House building form is not allowed for new development on a nonconforming Zone Lot located in a S-SU-FA zone district.
- c. The Tandem House building form may not be used when another building form, such as the Suburban House or Urban House building form, is allowed in the same zone district and the nonconforming Zone Lot's size or width is less than what is allowed for the Tandem House building form.

**B. Applicable Detached Accessory Building Form(s) for Development on Nonconforming Zone Lots**

Development of a detached accessory structure, including alterations to an existing detached accessory structure, on a nonconforming Zone Lot shall comply with the standards for a detached accessory building form permitted in the zone district.

**C. Application of Building Form Standards**

1. Development on a Nonconforming Zone Lot under the selected building form shall comply with all applicable building form standards, except that compliance with a building form's minimum Zone Lot area or width standards is not required for new development.
2. Development under the selected building form shall comply with the Setback and Building Coverage by Zone Lot Width form standards that align with the Nonconforming Zone Lot's width.

**12.10.3.5 Examples**

- A. For example, in the U-SU-C~~1~~ zone district, a Zone Lot of 4,500 square feet in total area and with a lot width of 40 feet, is nonconforming. The owner may develop an Urban House building form on the Nonconforming Zone Lot, despite the lot's noncompliance with the 5,500 square foot area and 50 foot width standards otherwise required for an Urban House form in that zone district. Development of the urban house on the existing 4,500 square foot Zone Lot must still comply with all other building height, siting, and design element form standards. Certain siting form standards, such as primary street and rear building setbacks or building coverage for an Urban House, are keyed to the lot width of the subject Zone Lot, including a nonconforming Zone Lot. In this example, the Urban House would be subject to setback and building coverage standards for a 40-foot wide Zone Lot, as shown in the Urban House Building Form Table in Article 5 of this Code.
- B. For example, in the U-SU-C~~1~~ zone district, a Zone Lot of 4,500 square feet in total area and with a lot width of 40 feet, is nonconforming. The building form standards for a Detached Accessory Dwelling Unit building does not require a minimum Zone Lot area as a prerequisite for development of such form. In this case, the owner could develop a Detached Accessory Dwelling Unit building on their lot.

- C. For example, in the U-TU-C zone district, a Zone Lot of 4,000 square feet in total area and a lot width of 37.5 feet, is nonconforming. The building form standards for a Duplex building requires a minimum of 4,500 square feet of Zone Lot area as a prerequisite for development of such form. In this case, the owner can only develop using the Urban House building form (allowing only a single dwelling unit use) because the Nonconforming Zone Lot is smaller (4,000 sf) than allowed for the Duplex building form (4,500 sf).

## SECTION 12.10.4 DEVELOPMENT ON CARRIAGE LOTS

### 12.10.4.1 Intent & Applicability

#### A. Intent

This Section 12.10.4 is intended to address a unique configuration of land in Denver defined by this Code as a "Carriage Lot," and to allow only a strictly limited range of permitted structures, uses, and activity to control for potential adverse impacts on surrounding uses.

#### B. Carriage Lot and Zone Lot(s)

A Carriage Lot describes a unique piece of land that is surrounded on all sides by Alleys and located in the center of a Block, and which has no frontage on a named or numbered Street. A single Carriage Lot may contain one or more Zone Lots. The entirety of the Carriage Lot may be a single Zone Lot (typically when no development exists on the Carriage Lot), or the Zoning Administrator may determine the Carriage Lot contains more than one Zone Lot because of existing development occurring before February 11, 1955. A Zone Lot on a Carriage Lot is a Nonconforming Zone Lot because of its lack of frontage on a named or numbered Street.

#### C. Applicability

This Section 12.10.4 applies to a nonconforming Zone Lot located on a Carriage Lot. This Section 12.10.4's standards for use and development on a Carriage Lot shall apply to each Zone Lot determined to be a part of or the entirety of a Carriage Lot.

### 12.10.4.2 Primary Uses and Building Forms Allowed

#### A. Primary Uses Allowed

The uses allowed on a Carriage Lot are limited to the following Primary Uses only:

1. Single-Unit Dwelling; or
2. Urban Garden, Unenclosed only.

#### B. Maximum Number of Primary Uses per Carriage Lot

1. No more than 1 primary Single-Unit Dwelling Use is allowed on a single Carriage Lot, regardless of the number of Zone Lots existing on the Carriage Lot.
2. No more than 1 Urban Garden primary use is allowed on each Zone Lot located on a Carriage Lot.

#### C. Use Limitations Applicable to All Primary Uses

Primary uses permitted on a Carriage Lot shall be subject to all use limitations specific to the primary use as stated in the Use ~~and Parking Standard~~ Table for the applicable zone district.

#### D. ~~Urban Garden Primary Use - Applicable Use Limitation~~

~~An Urban Garden primary use established on a Carriage Lot or portion thereof is exempt from providing minimum vehicle and bicycle parking otherwise required in the applicable Use and Parking Table for the subject zone district.~~

Figure 13.1-76

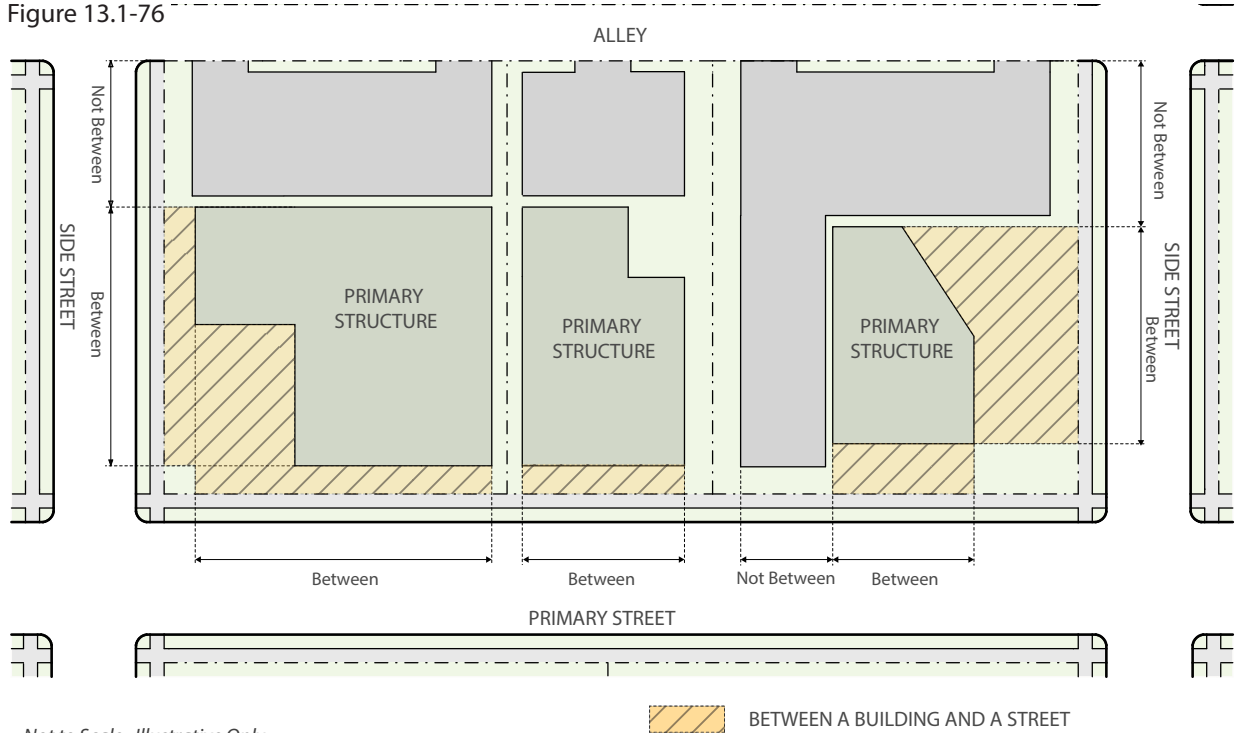

### 13.1.5.18 Floor Area Ratio (FAR)

#### A. Rule of Measurement - FAR

Floor area ratio (FAR) is the ratio of gross floor area of a building to the Zone Lot Area on which the building is located. For purposes of this Section 13.1.5.18 only, "Zone Lot Area" shall include all land area required by the Department of Transportation and Infrastructure ("DOTI") to be dedicated for public purpose, when such dedication is contemporaneous with or necessitated by Development of the Zone Lot.

**For example:** 43,560 square feet of building on one acre of land (43,560 sq. ft.) would equal a 1:1 floor area ratio. See Figure 13.1-77.

#### B. Calculation of Gross Floor Area

For purposes of calculating FAR, "gross floor area" means the sum of the gross horizontal areas of the several floors of a building, including interior balconies and mezzanines, but excluding exterior balconies. All horizontal dimensions of each floor are to be measured by the exterior faces of walls of each such floor. The floor area of a building shall include the floor area of accessory buildings on the same zone lot, measured the same way. In computing gross floor area the following exclusions shall apply:

1. Any floor area devoted to mechanical equipment serving the building, provided that the floor area of such use occupies not less than 75 percent of the floor area of the story in which such mechanical equipment is located.
2. Any floor area in a story in which the floor above is less than 6 feet above the finished grade for more than 50% of the total building perimeter.
3. Any floor area used exclusively as parking space for vehicles and/or bicycles. This exclusion shall not apply in the D-GT or D-CPV-C zone districts where any floor area used exclusively as parking space for vehicles and/or bicycles shall be included in the calculation of gross floor area.

- Any floor area that serves as a pedestrian mall or public access way to shops and stores.
- ~~For purposes of calculating parking amounts, see rule provided in Article 10, Division 10.4 Parking and Loading.~~

Figure 13.1-77

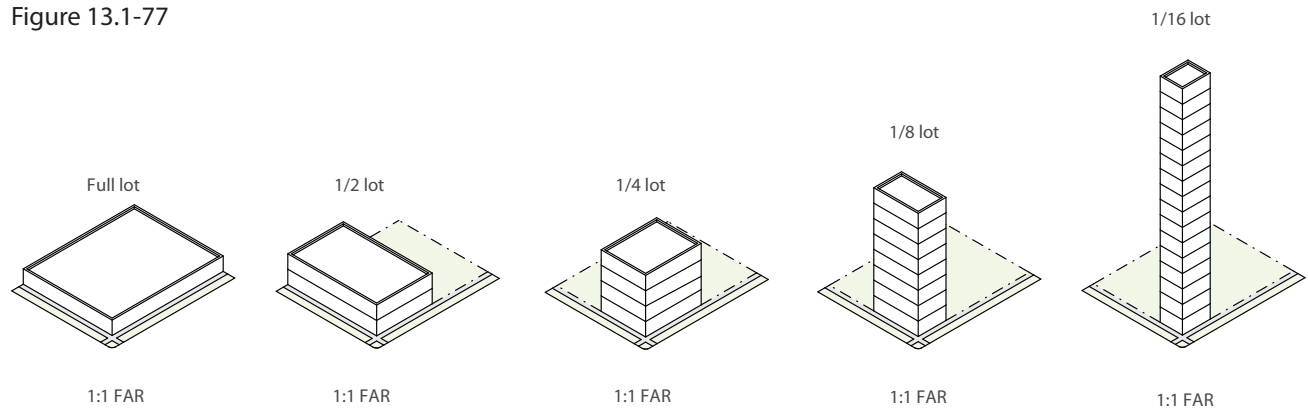

## SECTION 13.1.6 DESIGN ELEMENT FORM STANDARDS

The design element form standards of this Code are defined and measured as set forth below.

### 13.1.6.1 Building Configuration

#### A. Front or Side Wall Length / Overall Structure Length or Width

- The length of the front or side wall of a structure, or the overall structure length, shall be measured parallel to the primary street, side street, or side interior zone lot line and includes the length of a Completely Enclosed Structure plus the length of any portion of any attached Partially Enclosed Structure(s), as shown in Figure 13.1-78.
- The overall structure width includes the length of a Completely Enclosed Structure plus the length of any portion of any attached Partially Enclosed Structure(s) and shall be measured parallel to the primary street zone lot line or the side street/side interior zone lot line, whichever zone lot line is shorter. When an overall structure width standard is not explicitly stated, the overall structure length standard shall apply to the front, side and rear walls of a structure.
- The Zoning Administrator shall determine the zone lot line corresponding with the overall structure width in cases where the length of the primary street zone lot line and side street/side interior zone lot line are equal.



## DIVISION 13.3 DEFINITIONS OF WORDS, TERMS & PHRASES

The following words, terms and phrases, when used in this Code, shall have the meanings respectively ascribed to them. Definitions of uses are found in Article 11, Division 11.12, Use Definitions.

### A

**Abandonment:** The voluntary relinquishment of an established use with the intent of permanently terminating such use or occupancy.

**Abut or Abutting:** To physically touch at a point or line; or to share a common property line, or zone lot line. Intervening streets and alleys destroy “abutting,” except where specifically allowed by this Code. For example, two zone lots that share a common zone lot line are “abutting” (and also “adjacent).”

**Access:** A way or means of approach to provide physical entrance to a property.

**Accessory Structure:** See definition of “Structure, Accessory”.

**Accessory Use:** See definition of “Use, Accessory.”

**Adjacent:** Sharing a zone lot line or being separated only by an alley. Named or numbered streets destroy adjacency, except where specifically allowed by this Code.

**Alley:** Public right-of-way that is less in size than a “local” street (as classified by the DOTI), which is not designed for general vehicle travel, but which is used primarily as a means of vehicle access to the rear of residences and business establishments.

**Alley, Private:** An Alley that has been reserved in perpetuity by deed, easement, subdivision plat, or similar legal means for the primary purpose of vehicle access, but not dedicated to the City for public use.

**Alter or Alteration:** Any structural change in the supporting or load-bearing members of a building or structure, including bearing walls, columns, beams, girders, floor joints.

**Antenna:** Any exterior transmitting or receiving devices mounted on a tower, building or structure and used in communications that radiate or capture electromagnetic waves, digital signals, analog signals, radio frequencies (excluding radar signals), wireless telecommunications signals or other communication signals.

**Applicant:** The owner or any other person with a recognized interest in the land for which development is proposed, or an authorized agent. The City may also be considered an applicant.

**Application, Complete:** See definition of “Complete Application” below.

**Arcade:** A covered passage, open on at least one side and accessible to the public at all times, extending along the outside wall of a building, and supported by arches or columns. “Arcade” shall not include off-street loading areas, driveways, off-street parking areas.

**Area Median Income:** Unless otherwise more specifically defined by this Code, shall have the same meaning as stated in D.R.M.C., Chapter 27, Article V Dedicated Funding for Affordable Housing.

D

**D.R.M.C.:** Denver Revised Municipal Code.

**Dedicated or Dedication:** The conveyance or setting aside of land to the City Council or its designee.

**Delineating Element:** A vertical Permanent Structure that defines a portion of the perimeter of a permitted Outdoor Gathering Area, such as a railing, fence, raised planter, wall or other similar element.

**Demolished or Destruction, Involuntary:** See “Involuntary Demolition or Involuntary Destruction.”

**Demolished or Demolition, Voluntary:** See “Voluntary Demolition or Demolished.”

**Denver Zoning Code:** This Code.

**Design Element Form Standards or Design Element Standards:** Those standards in this Code that regulate building configuration (massing or sculpting of the building form), transparency, and building entrances

**Development:** Any of the following activities:

1. Any construction activity, grading and/or ongoing operation that changes the basic character or the use of the environment in which the construction activity, grading, or operation occurs; or any use or extension of the use of land; but not including total demolition of any structure.
2. ~~Creation of Aa new parking area; or an expansion of an existing parking area; a change in the use of a structure that changes the off-street parking requirement; or a change in the gross floor area of a structure that changes the off-street parking requirement.~~

**Development, Residential:** Development intended for residential occupancy.

**DIA Airport Influence Area:** An area within the City of Denver proximate to Denver International Airport (DIA), which is recognized by the City Council as containing lands that are expected to be significantly affected by noise and/or safety hazards associated with aircraft operations associated with DIA.

**Disability:** With respect to an individual, a physical or mental impairment that substantially limits one or more of the major life activities of such individual; a record of such impairment; or being regarded as having such an impairment.

**Person (Or People) with a Disability (or Disabilities):** A person with a physical or mental impairment that substantially limits a major life activity.

**Display Surface or Face:** The area made available by the sign structure for the purpose of displaying the message.

**Dormer:** A framed window unit projecting through the sloping plane of a roof.

**Drive Aisle:** An improved and maintained way providing vehicular access within an Off-Street Parking Area.

## G

**GFA:** Gross Floor Area. See definition of “Gross Floor Area” below.

**Gable:** The upper portion of a sidewall that comes to a triangular point at the ridge of a sloping roof.

**Gallery:** See definition of “Arcade.”

**Garage:** A building or part of a building wherein motor vehicles are housed or stored.

**Garage, Private:** A garage that is not operated for gain and in which no business is conducted.

**Glare:** The sensation produced when a source of light in excess of 1650 lumens is directly visible or light that is so bright that it causes annoyance, discomfort, or loss in visual performance.

**Grade, Finished:** The final elevation of the ground surface after development.

**Grade, Original:** The grade of the zone lot before development begins. If there was a structure on the zone lot that was demolished, the grade prior to demolition of the structure. If there is no structure on the property, the natural grade of the property prior to any modification, except that in new developments, original grade shall mean the approved and recorded grade.

**Grading:** The act of excavation or filling or combination thereof or any leveling to a smooth horizontal or sloping surface on a property, but not including normal cultivation associates with a permitted agricultural use or operation.

**Gross Floor Area:** The sum of the gross horizontal areas of each floor level of a Completely Enclosed Structure as measured from the exterior faces of the exterior walls of each such level. With the exception of Suburban House, Urban House, Tandem House, Duplex and all detached accessory structure building forms, the horizontal area at each level shall also include the area of exterior Unenclosed Porches covered by a roof and abutting more than one Exterior Wall, the area of Exterior Balconies covered by a roof and abutting more than one Exterior Wall, the area of interior mezzanines, and the area within Building Connectors. In lieu of this definition, “Gross Floor Area” for purposes of calculating [maximum vehicle parking standards](#), required [bicycle parking spaces](#), and off-street loading amounts is set forth in Section 10.4.4, Minimum and Maximum [Vehicle](#) Parking.

**Ground Cover:** Low plantings used instead of turf where space does not allow turf, where xeriscaping is desired, or where a more decorative affect is desirable. Ground covers are typically lower than 6 inches in height.

**Guideline:** An indication of policy or preferences; compliance is not mandatory like a standard, but rather compliance is encouraged to further the City’s land use goals and policies. A zoning application may not be denied solely for failure to comply with a guideline.

P

**Parapet Wall:** That part of any wall that extends entirely above the surface of the adjacent roof.

**Parking, Accessory:** A specific type of accessory use, comprised of surface or garage (structured) parking located on the same zone lot as the primary use such parking is ~~required~~ ~~or~~ intended to serve.

**Parking Aisle:** Parking “Aisles” mean the part of the parking lot that directly abut parking stalls and are used for vehicular access to the parking stalls.

**Parking, Commercial:** An open, hard-surfaced area or structure, other than street or public way, to be used for the storage, for limited periods of time, of operable passenger automobiles and commercial vehicles, and available to the public, whether for compensation, free, or as an accommodation to clients or customers.

**Parking, Shared or Shared Parking:** Joint or shared use of parking spaces available to multiple land uses with different parking demand patterns throughout the day.

**Parking, Tandem:** The parking of 2 vehicles either end to end, vertically stacked, or front to back in a parking space, such that if both vehicles are parked, one vehicle must be moved in order for the other vehicle to exit the parking space.

**Parking Area, Off-Street:** See “Off-Street Parking Area”.

**Parking Ratio:** A ratio expressing the number of parking spaces per dwelling unit, or per certain amounts of square footage or commercial space, or per number of occupants or employees.

**Parking Space:** A storage area for a motor vehicle that is directly accessible to an access aisle, street, or alley, and which is not located on a public right-of-way unless specifically permitted by this Code.

**Parking, Surface:** A storage area for motor vehicles that is not within a Completely Enclosed Structure or part of a Garage Parking use as defined in Section 11.12.4.3.B.1, including surface parking lot, ~~deck parking~~ and tuck-under parking.

**Parkway:** A type of boulevard that the city has designated as a “Parkway” according to Chapter 49 of the D.R.M.C.

**Patently Offensive:** So offensive on its face as to affront current community standards of tolerance.

**Patio:** A hard surfaced area 12 inches or less above adjacent finished grade and which is not used exclusively as a pedestrian route. See also the related definition of "Porch."

**Pedestrian and/or Transit Mall:** A public right-of-way and/or public rights-of-way from which general vehicular traffic shall be excluded except that public transportation vehicles, emergency vehicles and other vehicles by special permit may be permitted, and which shall have been specially constructed with amenities to enhance a primarily pedestrian environment.

**Pedestrian Connection:** A clear, obvious, and publicly accessible route and connection between the Primary Street and the primary uses within the building.

## R

**Rail Transit Station Platform:** The area of a Mass Transit Railway System station that is intended for passenger queuing, loading and unloading from the rail car and runs parallel to and abutting the rail tracks, the boundary of which is only the area intended for passenger access to the rail car.

**Railroad Facilities:** Terminal related to a freight railway; or a railway yard, maintenance, or fueling facility related to a passenger or freight railway.

**Rear of Zone Lot:** See "Zone Lot, Rear."

**Record Document:** The recorded subdivision, plat, or deed that specifies historic lot dimensions and lot area applicable to a property.

**Recreational Vehicle:** A vehicular-type, portable structure without permanent foundation for personal household use, which can be towed, hauled or driven and primarily designed as living accommodation for recreational, camping and travel use and including travel trailers, truck campers, camping trailers, and self-propelled motor homes.

**Recreational Vehicle, Large:** A Recreational Vehicle that has a gross vehicle weight greater than 10,000 pounds. For purposes of this Code, the Term "Recreational Vehicle" includes "Large Recreational Vehicle".

**Recyclable Material:** Reusable materials including metals, glass, plastic, wood, and paper that are intended for remanufacturing or reconstitution. Recyclable materials do not include junk, rubbish, refuse, or hazardous waste.

**Reference Zone Lot or Reference Zone Lots:** See "Zone Lot, Reference."

**Registry Identification Card:** That document issued by a state health agency, which identifies a patient authorized to engage in the medical use of marijuana, as required by Colorado Revised Statutes, Section 25-1.5-107(7), as may be amended.

**Replacement Cost:** The amount it would cost to replace an asset at current market prices.

**Required Entrance:** See "Entrance, Required," above.

**Residential Accommodations:** Any building or part of a building used or intended to be used for sleeping accommodations by a person or group of persons. Other housekeeping facilities may be provided.

**Residential Development:** See "Development, Residential."

**Residential Occupancy or Residential Use:** Any Structure or part of a Structure in which a person or group of persons are provided with sleeping accommodations. Other housekeeping accommodations may also be provided. Residential Occupancy or Residential Use includes any Structure or part of a Structure permitted for any Use Category or Specific Use Type listed within the Primary Residential Use Classification in this Code's Use ~~and Parking~~ Tables.

**Residential Only Structure or Residential Only Building:** A Structure used entirely for Residential Occupancy or Residential Use.

**Residential Structure:** See definition of "Structure, Residential," below.

**Street Property Line:** A common boundary between private property and a dedicated street or alley.

**Structural Feature:** Any part of a structure which is designed for or indicative of the intent to accommodate any given use.

**Structure:** Anything constructed or erected that is permanently affixed to the ground or that is attached to something other than wheels having permanent location on the ground; or any production or piece of work, artificially built up or composed of parts and joined together in some definite manner.

*Structure - Group A:*

**Structure, Completely Enclosed:** A structure enclosed by a permanent Roof less than 50% open to the sky and by solid Exterior Walls.

**Structure, Partially Enclosed:** A structure enclosed by a Roof less than 50% open to the sky and which does not have solid Exterior Walls.

**Structure, Open:** A structure that is at least 50% open to the sky.

*Structure - Group B:*

**Structure, Conforming:** A structure which, when originally constructed, was in full compliance with all zoning regulations applicable to structures, and which complies with the following current regulations applicable to structures:

1. All building form standards in this Code, as applicable;
2. Standards for permitted structures in the Downtown, Campus, I-A, and I-B zone districts, as applicable, and
3. Standards established in Division 10.3, Multiple Buildings on a Single Zone Lot, as applicable.

A structure that has received an administrative adjustment or variance that allows for an exception from full compliance with this Code shall be considered a Conforming Structure. A structure that meets this definition of “Conforming Structure,” but which does not comply with zoning standards that are inapplicable to structures (e.g., site design standards such as landscaping, parking amount, or signage), is still a “Conforming Structure” under this Code.

**Structure, Compliant:**

**A.** A Structure that was lawful prior to the adoption, revision, or amendment to this Code, but which fails by reason of such adoption, revision, or amendment, to comply with one or more of the following Building Form Standards in this Code:

1. Height Standards
  - a. Minimum, feet
  - b. Maximum, feet and stories
  - c. Maximum, feet and stories with incentives
  - d. 3rd Avenue CCN bulk plane
2. Siting Standards
  - a. Building setback standards, including Primary Street setback standards

**Use, Conforming:** A use or activity that was lawful when originally established and that complies with current use limitations applicable to the use or activity in the zone district in which it is located. A use or activity that was lawful when originally established, but which, by reason of the adoption of or revision to this Code, does not comply with a review procedure (e.g., special exception review), or with a reduceable spacing/distance requirement, or with a site development or design standard (e.g., parking, landscaping, and signage) otherwise applicable to such use, shall be classified as a “conforming use.”

**Use, Illegal:** Any use, whether of a building or other structure, or of land, in which a violation of any provision of this Code has been committed or shall exist.

**Use, Nonconforming:** A use or activity that was lawful when originally established, but which is no longer permitted in the zone district in which such use or activity is located.

**Use, Permitted:** Any use listed as a primary use, a temporary use, a home occupation, an accessory use, a use subject to special exception review, or a use subject to limitations, as approved according to the required use review procedure.

**Use, Primary or Principal:** The main or primary purpose for which land and the structures thereon are used, or for which land and the structures thereon may be maintained or occupied according to this Code.

**Use, Prohibited:** A use that is not permitted in a zone district (“NP” in the ~~Summary Use and Parking~~ Tables).

**Use, Special Exception:** A use that is listed in the ~~Summary Use and Parking~~ Table as a use permitted subject to the special exception review by the Board of Adjustment, as set forth in Article 12 (“ZPSE” in use table).

**Use, Temporary:** A use established for a fixed period of time with the intent to discontinue such use upon the expiration of the time period.

**Use and Parking Table:** Tables found in Articles 3, 4, 5, 6, 7, 8, and 9 of this Code, which list: (a) the principal, accessory, and temporary uses permitted in each zone district; ~~and~~ (b) the type of review procedure (e.g., zoning permit, zoning permit review with informational notice, special exception review.) required prior to a use’s establishment; ~~and (c) the bicycle and vehicle parking requirements for each use.~~

**Use Category:** A category of uses within a “Use Classification.” “Use Categories” are based on common functional, product, or physical characteristics, such as the type and amount of activity, the type of customers or residents, how goods or services are sold or delivered, and site conditions. A “Use Category” may be further subdivided into “Specific Use Types.”

**Use Classification:** The broadest grouping of land uses in this Code, based on generally accepted industry groupings, similar descriptions of planning goals or functions, similar permitted use types, and similar permitted density/intensity of use.

**Use Type or Specific Use Type:** The finest-grained category of uses in this Code; a “Use Type or Specific Use Type” is a sub-category of a “Use Category.” It is used when necessary to tailor the regulatory treatment to address issues such as the relative intensity of the use, issues related to building type, possible effects on neighboring land uses, consistency with zone district purpose and goals, or possible operational externalities (such as odor, glare, or noise).

## Sec. 59-2. Former chapter 59.

- (a) Chapter 59 of the Denver Revised Municipal Code as filed with the Denver City Clerk on 20<sup>th</sup> day of May 2010, at City Clerk Filing No. 10-512, ("Former Chapter 59"), shall remain in full force and effect for any land not rezoned to zone districts in the Denver Zoning Code.
- (b) For lands retaining their zoning designation under the former chapter 59, including land zoned planned unit development (PUD), land zoned with waivers and conditions and land subject to a planned building group site plan, all provisions of the former chapter 59, including procedures, shall apply, except as explicitly stated in sections 59-2(c)(8), 59-2(c)(14), 59-2(c)(15), 59-2(c)(16), 59-2(c)(17), 59-2(c)(23), 59-2(c)(29) and 59-3(b) below.
- (c) No changes shall be enacted to the text of the former chapter 59 after June 25, 2010; however, regulation of lands retaining their zoning designation under the former chapter 59 is subject to the following requirements and allowances:
  - (1) For purposes of applying the limitations on bulk planes and building heights in section 59-96 of the former chapter 59, the "protected districts" identified therein shall also include the zone districts defined as "protected districts" in section 13.3 of the Denver Zoning Code.
  - (2) Reserved.
  - (3) For purposes of applying the "exception to use enclosure requirement" for mixed use zone districts (C-MU, R-MU, and T-MU zones) in section 59-302(4)b.1, and 2 of the former chapter 59, the residential districts identified therein shall also include the zone districts defined as "protected districts" in section 13.3 of the Denver Zoning Code.
  - (4) For purposes of applying the restrictions on the siting of outdoor animal runs within twenty (20) feet of a habitable residential structure stated in section 59-2(16) of the former chapter 59, the residential zone districts identified therein shall also include the zone districts defined as "protected districts" in section 13.3 of the Denver Zoning Code.
  - (5) For purposes of applying the five-foot side setback for structures that are not single-unit or two-unit dwellings, and which have ground floor commercial or which are four (4) or more stories in height, as required in the mixed use zoning districts in section 59-312(3) of the former chapter 59, the residential zone districts identified therein shall also include all SU and TU zone districts as established on the official zoning map under the Denver Zoning Code.
  - (6) For purposes of applying various zoning protections to residentially zoned properties, the terms "residential district(s)," "residential zone district(s)," "residential zone(s)," "residentially zoned lot," and "residentially zoned zone lot" used throughout former chapter 59 shall also include the zone districts defined as a "residential zone district or residential district" in division 13.3 of the Denver Zoning Code.
  - (7) Gardens shall be allowed as an accessory use common, customary and incidental to a primary residential use, and shall comply with all limitations generally applicable to accessory uses stated in former chapter 59, sections 59-87 and 59-88. In addition, marijuana grown as part of a garden accessory to a primary residential use shall comply with all applicable limitations found in the Denver Zoning Code, including, but not limited to, section 11.8 (Uses accessory to primary residential uses— Limitations).
  - (8) Any portion of a general development plan approved under former chapter 59 may be repealed in accordance with Section 12.4.12 of the Denver Zoning Code.
  - (9) For purposes of regulating "cluster multiple-unit dwellings" throughout the former chapter 59, each "separate, independent dwelling unit" that comprises a "cluster multiple unit dwelling" use in section



- 59-2(72) of former chapter 59 may contain a "household" as defined in section 11.12.2.1.B.3 of the Denver Zoning Code.
- (10) For purposes of regulating "dwelling, multiple unit" throughout the former chapter 59, each "separate independent dwelling unit" that comprises a "dwelling, multiple unit" use in section 59-2(95) of former chapter 59 may contain a "household" as defined in section 11.12.2.1.B.3 of the Denver Zoning Code.
  - (11) For purposes of regulating "dwelling, single unit" throughout the former chapter 59, each "housekeeping unit" that comprises a "dwelling, single unit" use in section 59-2(96) of former chapter 59 may contain a "household" as defined in section 11.12.2.1.B.3 of the Denver Zoning Code.
  - (12) Reserved.
  - (13) The definition of residence for older adults in section 59-2(230) of former chapter 59 shall only apply to a residence for older persons serving nine (9) or more residents; a residence for older adults serving less than nine (9) residents shall be determined as either a "dwelling, single unit" or "dwelling, multiple unit" based on the type of structure containing the use, and shall only be permitted as a "dwelling, single unit" or "dwelling, multiple unit" in zone districts allowing the use.
  - (14) For purposes of administering former chapter 59, section 59-51, the creation and alternatives of the board of adjustment shall follow the procedures and requirements of Denver Zoning Code section 12.2.6.2.
  - (15) Regarding variances for land retaining its zoning designation under former chapter 59 and containing only a single unit dwelling use or only a two-unit multiple unit dwelling use, the community planning and development department and the board of adjustment shall apply the concurring vote required for a variance, applicability and limitations, review process, review criteria, and requirements and limitations after approval provisions in the Denver Zoning Code, sections 12.2.6.9.A. and 12.4.7, in place of former chapter 59, sections 59-54(2) and 59-55(a).
  - (16) The zoning administrator may grant administrative adjustments for the zoning standards stated in the Denver Zoning Code section 12.4.5.2.B-G, and Table 12.4.5.H.3-1 for land retaining its zoning designation under former chapter 59 and containing only a single unit dwelling use or only a two-unit multiple dwelling use, using the review process and review criteria of Denver Zoning Code, section 12.4.5. The zoning administrator shall determine whether an administrative adjustment listed in Denver Zoning Code Table 12.4.5.2 applies to a specific standard in former chapter 59.
  - (17) The zoning administrator may grant an administrative adjustment to former chapter 59 standards, procedures, or definitions to comply with federal or state law by applying the applicability, extent of adjustment authorized, and review criteria in section 12.4.5.2.A of the Denver Zoning Code.
  - (18) A temporary managed community is allowed as a temporary use by zoning permit in all zone districts in the former chapter 59, subject to all applicable limitations, definitions, and procedures of the Denver Zoning Code regarding a temporary managed community use. The use limitations of Denver Zoning Code section 11.11.17.2 for a temporary managed community in SU, TU, and RH zone districts apply to a temporary managed community use in the following circumstances:
    - a. Land retaining R-X, R-0, R-1, R-2, R-2-A, or R-2-B zone districts under the former chapter 59;
    - b. Land retaining R-X, R-0, R-1, R-2, R-2-A, or R-2-B zone districts under the former chapter 59, and subject to waivers or conditions; or
    - c. Land retaining a planned unit development (PUD) zone district under the former chapter 59 if the PUD's district plan describes the types of uses allowed as those allowed in the R-X, R-0, R-1, R-2, R-2-A, or R-2-B zone districts.

- (19) One accessory dwelling unit use is permitted as accessory to each primary dwelling unit containing a primary single unit dwelling in all zone districts in the former chapter 59 that allow new single unit dwellings.
- (20) Where permitted in the former chapter 59, all accessory dwelling unit uses and detached accessory structures containing an accessory dwelling unit use are subject to the following:
- a. Mobile homes, recreational vehicles, and trailers shall not be used as accessory dwelling units.
  - b. The limits on minimum square feet of gross floor area per occupant of an accessory dwelling unit use stated in section 59-87(c)(1)h.1 of former chapter 59 are not required.
  - c. The requirement for roof and exterior wall materials of an accessory dwelling unit to be comparable in composition and appearance to that of the use by right stated in section 59-87(c)(1)h.3.ix of former chapter 59 are not required.
- (21) In addition to the requirements stated in subsection (c)(20) above, on land retaining RS-4, R-X, R-0, R-1, R-2, R-2-A, or R-2-B zone districts, with or without waivers or conditions, under the former chapter 59, accessory dwelling unit uses and structures containing an accessory dwelling unit use shall meet the following requirements:
- a. The maximum building height of a detached accessory structure containing an accessory dwelling unit use shall be twenty-four (24) feet measured according to section 59-2(52) (building height measurement) of the former chapter 59.
  - b. With the exception of eaves, flag poles, antennas, chimneys, flues, vents, flush mounted solar panels, and evaporative coolers, no part of any structure shall project through bulk planes which shall be applied as follows:
    1. On a zone lot forty (40) feet wide or less, the bulk plane shall begin at a horizontal line which is located directly above the side lot line and which passes through a point twelve (12) feet above the midpoint of such lot line.
    2. On a zone lot greater than forty (40) feet wide, the bulk plane shall begin at a horizontal line which is located directly above the side lot line and which passes through a point ten (10) feet above the midpoint of such lot line.
  - c. A detached accessory structure containing an accessory dwelling unit use shall be located within the rear thirty-five (35) percent of the zone lot.
  - d. The minimum side setbacks of a detached accessory structure containing an accessory dwelling unit use shall be the same as those for the primary structure in the applicable zone district.
  - e. In the RS-4, R-X, R-0, and R-1 zone districts, the minimum rear setback of a detached accessory structure containing an accessory dwelling unit use shall vary based on its location in the applicable Future Neighborhood Context set forth in the most recently adopted version of Blueprint Denver:
    1. Blueprint Denver suburban neighborhood context: twenty (20) feet where the accessory dwelling unit structure is greater than seventeen (17) feet in height—otherwise, ten (10) feet.
    2. Blueprint Denver urban edge neighborhood context: twelve (12) feet where no alley abuts the rear zone lot line and the accessory dwelling unit structure is greater than seventeen (17) feet in height—otherwise, five (5) feet.
    3. Blueprint Denver urban neighborhood context: five (5) feet where no alley abuts the rear zone lot line or where garage doors face an alley—otherwise, zero feet.

- f. In the R-2, R-2-A, and R-2-B zone districts, the minimum rear setback shall be five (5) feet where no alley abuts the rear zone lot line or where garage doors face an alley. Otherwise the minimum rear setback shall be zero feet.
  - g. The maximum building footprint of a detached accessory structure containing an accessory dwelling unit use shall be:
    - 1. Eight hundred sixty-four (864) square feet when located on a zone lot with an area of seven thousand (7,000) square feet or less; or
    - 2. One thousand (1,000) square feet when located on a zone lot with an area greater than seven thousand (7,000) square feet.
  - h. The maximum gross floor area of an accessory dwelling unit use located within a primary structure or a detached accessory structure shall be:
    - 1. On a zone lot with seven thousand (7,000) square feet or less: Eight hundred sixty-four (864) square feet; or
    - 2. On a zone lot greater than seven thousand (7,000) square feet: one thousand (1,000) square feet.
  - i. In the RS-4, R-X, R-0, and R-1 zone districts, the ownership and owner occupancy requirements shall be the same as those for an accessory dwelling unit use in a single-unit zone district in the Denver Zoning Code.
  - j. In the R-2, R-2-A, and R-2-B zone districts, an accessory dwelling unit use is not required to be operated and maintained under the same ownership as the primary dwelling unit to which it is accessory.
  - k. In the R-2, R-2-A, and R-2-B zone districts, an owner of the existing primary dwelling unit is not required to occupy the existing primary dwelling unit as the owner's primary residence.
- (22) In addition to the requirements stated in subsection (c)(20) above, on land retaining R-3, R-3-X, R-4, R-4-X, R-5, B-1, B-2, B-3, B-4, B-5, B-5-T, B-7, B-8, B-8-A, B-8-G, B-A-1, B-A-3, B-A-4, CCN, MS-1, MS-2, MS-3, R-MU-20, R-MU-30, C-MU-10, C-MU-20, C-MU-30, H-1-A, H-1-B, H-2, and Gateway (within Gateway use areas allowing single unit dwelling uses) zone districts, with or without waivers or conditions, a structure containing an accessory dwelling use shall comply with the regulations in former chapter 59, sections 59-87(c) and 59-312, with the following exceptions:
- a. An accessory dwelling unit use is not required to be operated and maintained under the same ownership as the primary dwelling unit to which it is accessory.
  - b. An owner of the existing primary dwelling unit is not required to occupy the primary dwelling unit as the owner's primary residence.
  - c. The maximum gross floor area of an accessory dwelling unit use located in a primary structure shall be seventy-five (75) percent of primary use gross floor area or eight hundred sixty-four (864) square feet, whichever is greater.
  - d. There shall be no maximum gross floor area applied to an accessory dwelling unit use located in a detached accessory structure.
- (23) Where a special zone lot plan for a planned building group approved under former chapter 59 specifies a total number of dwelling units or a maximum density of dwelling units, the zoning administrator may allow one (1) or more accessory dwelling units in excess of the specified number of dwelling units or the specified maximum density according to one of the following procedures:

- a. By zoning permit according to the procedures of the former chapter 59 zoning code for an accessory dwelling unit use located within a primary structure or detached accessory structure that is allowed by the approved planned building group, and the building footprint of the approved structures will not be expanded; or
  - b. By the minor change procedure for a planned building group described in section 59-621 for an accessory dwelling unit use located within a primary structure or a new or expanded detached accessory structure and the building footprint will be expanded beyond those shown in the approved planned building group. Accessory dwelling unit uses and detached accessory structures containing an accessory dwelling unit use will not be considered a change in the character of development for the purposes of administering 59-621(1) or an increase in the intensity of use for the purposes of administering 59-621(3).
- (24) The following sections of the Denver Zoning Code regarding use limitations apply to a permitted unenclosed eating place use on land retaining its zoning designation under former chapter 59 ("Unenclosed eating place") in place of any zoning standards and limitations in former chapter 59 for an unenclosed eating place:
- a. Denver Zoning Code sections 11.10.14.2, and 11.10.14.3.A and B.
  - b. Denver Zoning Code section 11.10.14.3.D, except for an unenclosed eating place in the following former chapter 59 zone districts: B-4; B-8; B-8-A; B-8-G; B-5; B-5-T; B-7; B-A-3; MS-1; MS-2; MS-3; PRV; or Gateway use areas MU1, MU2, TCU, or TSU; and
  - c. Denver Zoning Code section 11.10.14.3.E, except for an unenclosed eating place in the following former chapter 59 zone districts: B-3; B-4; B-8; B-8-A; B-8-G; B-5; B-5-T; B-7; CCN; B-A-2; B-A-3; B-A-4; MS-1; MS-2; MS-3; PRV; or Gateway use areas MU1, MU2, TCU, or TSU;
- (25) The zoning administrator may waive or modify the requirements of 11.10.14.3.B.2—8 for an unenclosed eating place in accordance with the process and review criteria of Denver Zoning Code section 11.10.14.3.C.
- (26) The zoning administrator may grant an unenclosed eating place the specific incentives of Denver Zoning Code section 11.10.14.3.C listed below in accordance with the process of section 11.10.14.3:
- a. An unenclosed eating place permitted in a main street district of former chapter 59 may reduce required off-street parking spaces in the amount specified for main street zone districts in the Denver Zoning Code.
  - b. An unenclosed eating place permitted in any zone district of former chapter 59, other than a main street district, may reduce required off-street parking spaces in the amount specified for districts in the suburban neighborhood context in the Denver Zoning Code.
- (27) An unenclosed eating place must follow the zoning permit with information notice process when the use would otherwise be subject to the approval of the board of adjustment under former chapter 59 section 59-54(3)u.
- (28) Any use that the board of adjustment may authorize as an outdoor eating exception under former chapter 59 section 59-54(3)u must follow the applicable provisions in subsection (24)—(28) above.
- (29) At the request of an applicant, the zoning administrator shall use the review process and criteria in Denver Zoning Code Section 12.3.7.2.A.3 to process an application from an individual property owner for an amendment to either (i) a development plan meeting the requirements below, or (ii) a zone lot within a development plan meeting the requirements below if the zone lot does not contain a single unit dwelling use or a multiple unit dwelling use with two units:

- a. A development plan originally approved by the development review committee or the zoning administrator; and
  - b. A development plan that under former chapter 59 requires all owners within the entire land area of the approved plan to apply for an amendment.
- (30) The use limitations of the Denver Zoning Code for an automobile services, light use containing an automobile fueling station apply to the former chapter 59 permitted uses of automobile gasoline filling station and automotive repair garage.
- (31) No minimum amount of vehicle parking is required for any land use or zone district in former chapter 59.
- (32) Minimum off-street parking requirements stated in former chapter 59 shall be used for calculation of density, height, and floor area premiums/bonuses, where allowed in former chapter 59.
- (33) Minimum off-street parking requirements stated in former chapter 59 shall be used for calculation of additional parking or excess parking, where regulated by former chapter 59.
- (34) The Manager shall not enforce any requirement for a minimum amount of vehicle parking stated in an approved regulating plan, Planned Building Group, or zoning permit approved under former chapter 59.
- (35) The Manager shall not enforce any requirement for a minimum amount of vehicle parking stated in an approved Planned Unit Development (PUD) zone district or zone district with waivers or conditions approved under former chapter 59.

(Ord. No. 333-10, eff. 6-25-10; Ord. No. 22-14, § 1, 1-13-14; Ord. No. 493-14, § 1, 9-15-14; Ord. No. 494-19, §§ 1, 2, 7-8-19; Ord. No. 584-19, § 1, 8-5-19; Ord. No. 213-21, § 1, 4-5-21; Ord. No. 93-22, § 4, 2-22-22; Ord. No. 375-23, § 1, 6-5-23; Ord. No. 413-23, § 1, 6-5-23; Ord. No. 416-23, § 1, 6-5-23; Ord. No. 482-23, §§ 1, 2, 6-12-23; Ord. No. 1303-24, § 1, 11-18-24; Ord. No. 1590-24, § 1, 12-16-24; Ord. No. 1867-24, § 1, 2-18-25; Ord. No. XXXX-25, 07-XX-25)

### **Sec. 27-217. Legislative findings.**

The city council hereby finds that a severe housing problem continues to exist within Denver with respect to the supply of housing relative to the need for affordable housing. Specifically, the city council finds that:

- (a) Demographics and analyses of new housing indicate that a large majority of private development is geared toward high-priced housing development and does not serve households earning less than one hundred (100) percent of area median income;
- (b) Development trends produce high-priced housing which does not serve a large segment of the population and limits housing available to low- and moderate-income households, thus failing to implement the housing goals of the HOST Strategic Plan, Comprehensive Plan 2040, and Blueprint Denver, calling for a city that is equitable, affordable, and inclusive;
- (c) Market forces, including continued population growth and unmet demand for new housing, result in highly priced housing, and a lack of economic incentive for developers to offer a more diversified price range of housing, and therefore such housing is not being created at a level that meets current demand;
- (d) Rapid regional growth and a strong housing demand have combined to make land and construction costs higher, limiting the areas where affordable housing is located;
- (e) Incomes of Denver's growing workforce has not kept pace with this rapid and significant increase in the cost of housing in Denver;
- (f) Ensuring a mix of incomes and access to homeownership and rental housing opportunities for low- and moderate-income households are high priorities for the city, and therefore the city has a strong interest in ensuring that the city's limited supply of developable land provides housing opportunities for all incomes of the workforce;
- (g) Land in Denver is highly limited and without a program requiring affordable housing to be built, it is unlikely based on current trends, new development will create affordable housing, leaving Denver residents without sufficient affordable housing;
- (h) Naturally occurring affordable housing, which is housing that may rent or sell at an affordable rate without affordability restrictions, has declined significantly in recent years thereby necessitating a program to assist in the development of affordable housing;
- (i) The city has deployed multiple funding strategies and programs which are successful in creating new affordable housing, but not at a pace sufficient to meet the growing demand of the workforce; and
- (j) Providing incentives to new development will improve the economic feasibility of providing a minimal percentage of affordable housing units as an integral part of new residential developments.

(Ord. No. 426-22, § 2, 6-6-22)

### **Sec. 27-218. Declaration of public policy.**

The city council hereby declares it to be the public policy of the city to:

- (a) Exercise the authority granted to the city pursuant to HB 21-1117 to regulate development in order to promote the construction of new affordable housing units;
- (b) In compliance with HB 21-1117, the city has demonstrated the following actions to increase the overall number and density of housing units within the city:

- (1) Changing its zoning regulations to increase the number of housing units allowed on a particular site;
  - (2) Promoting mixed-use zoning that permits housing units be incorporated in a wider range of developments;
  - (3) In certain zones, permitting more than one dwelling unit per lot in traditional single-family lots;
  - (4) Increasing the permitted household size in single-family homes;
  - (5) Promoting denser housing development near transit stations and places of employment;
  - ~~(6) Granting reduced parking requirements to residential or mixed-use developments that include housing near transit stations or affordable housing development;~~
  - (7) Granting density bonuses to development projects that incorporate affordable housing units;
  - (8) Materially reducing or eliminating certain utility charges, regulatory fees, or taxes imposed by the city applicable to affordable housing units; and
  - (9) Granting affordable housing development material regulatory relief from any type of zoning or land development regulations that would ordinarily restrict the density of new development.
- (c) Encourage the construction of new affordable housing units alongside market rate housing units within mixed income residential developments by offering incentives to increase the overall supply and availability of housing;
- (d) Provide property owners or land developers with alternatives to the construction of new affordable housing units as required by HB 21-1117;
- (e) Implement the comprehensive plan goal to create a Denver that's equitable, affordable, and inclusive;
- (f) Increase the availability of additional low- and moderate-income housing to address existing and anticipated future housing needs of the workforce in Denver and the unmet needs of residents in Denver; and
- (g) Ensure diverse housing options continue to be available for households earning at or below the area median income.

(Ord. No. 426-22, § 2, 6-6-22)

## **Sec. 27-219. Definitions.**

The following words and phrases, as used in this article, have the following meanings:

- (a) *AMI or area median income* means the median income for the Denver metropolitan area, adjusted for household size, as calculated by the U.S. Department of Housing and Urban Development.
- (b) *Affordable housing plan* means a plan approved by the executive director of the department of housing stability outlining the number and type of income restricted units to be provided when an applicant elects to build income restricted units on-site as required by this article.
- (c) *Affordable housing project* means a residential rental or ownership development in which the number of affordable units for that project is at least equal to the number and affordability level of IRUs otherwise required under section 27-224(c).
- (d) *Applicant* means any person, firm, partnership, association, joint venture, corporation, or any other entity or combination of entities, or affiliated entities and any transferee of all or part of the real

(b) *Base incentives for on-site compliance.*

- (1) To promote the construction of on-site IRUs, an applicant providing IRUs on-site pursuant to the requirements in subsection (a) is eligible for the following incentives for the applicable residential development:
- a. *Permit fee reduction.* An applicant will receive a building permit fee reduction of six thousand five hundred dollars (\$6,500.00.00) per IRU in a typical market area and ten thousand dollars (\$10,000.00) per IRU in a high market area. The building permit fee reduction shall not exceed fifty (50) percent of the total building permit fee.
  - ~~b. *Reduced minimum vehicle parking required by the Denver Zoning Code.* An applicant may utilize the alternative minimum vehicle parking ratios allowed in article 10 of the Denver Zoning Code.~~
  - b e. *Commercial, sales service and repair street level exemption to linkage fee.* An applicant may receive an exemption from the requirement to pay a linkage fee for the gross floor area of a primary commercial sales, services, and repair use located on the street level of a structure. As used in this subsection, the terms "primary commercial sales, services, and repair use" shall have the same meaning as the term is defined in article 11 of the Denver Zoning Code and "Street level" shall have the same meaning as the term is defined in article 13 of the Denver Zoning Code.
- (2) Notwithstanding the applicability of this division, any residential development that is exempt pursuant to section 27-222(c) or (d) may receive the base incentives set forth in this section.

(c) *Enhanced on-site compliance; incentives.*

- (1) *Enhanced incentives.* To increase the overall supply of housing and encourage applicants to provide on-site IRUs in excess of the base requirements specified in subsection (a), an applicant is eligible for the incentives set forth in a. through b e. of this subsection if the applicant provides IRUs as follows:

Market Area	Applicant Compliance Options	Minimum percent of total dwelling units to be IRUs	Maximum AMI for eligible households	
High Market Area	H-1E	12% of total dwelling units	Rental developments: 60% of AMI	Ownership developments: 80% of AMI
	H-2E	18% of total dwelling units	Rental developments: An effective average of 70% of AMI	Ownership developments: An effective average of 90% of AMI
Typical Market Area	T-1E	10% of total dwelling units	Rental developments: 60% of AMI	Ownership development: 80% of AMI
	T-2E	15% of total dwelling units	Rental developments: An effective average of 70% of AMI	Ownership developments: An effective average of 90% of AMI



- a. *Access to base incentives.* An applicant is eligible for the base incentives for on-site compliance set forth in section 27-224(b)(1).
- b. *Height and floor area increase.* A residential development shall be entitled to an increase in building height and floor area ratio in accordance with the provisions set forth in articles 8 and 10 of the Denver Zoning Code.
- ~~c. *Vehicle parking exemption.* A residential development shall be entitled to a vehicle parking exemption in accordance with the provisions set forth in article 10 of the Denver Zoning Code.~~
- (2) Notwithstanding the applicability of this division, any residential development that is exempt pursuant to section 27-222(c) or (d) may receive the enhanced incentives set forth in this subsection if the residential development provides the percentage of IRUs specified in subsection (c)(1).
- (d) *Affordable housing plan submission.* An applicant who chooses to provide IRUs on-site pursuant to this section shall submit an affordable housing plan to HOST. The affordable housing plan must be submitted in conjunction with the formal site development plan or, if no site development plan is required, at time of the applicable permit application. The director shall review the proposed affordable housing plan for consistency with the requirements of this article prior to approval of the site development plan or applicable permit. The director shall approve, approve with conditions, or reject the affordable housing plan. A site development plan or applicable permit may not be approved until an affordable housing plan is approved by the director.
- (e) *Covenant restriction.* Residential developments, specific IRUs, or both, shall carry deed restrictions, restrictive covenants, or other forms of affordability restrictions, in the form approved by the director. No temporary or final certificate of occupancy shall be issued until a deed restriction, restrictive covenant, or other form of affordability restriction is recorded in the real property records of the Clerk and Recorder for the City and County of Denver and encumbers the residential development or IRUs, as applicable.
- (f) *Minimum standards and requirements for on-site IRUs.*
  - (1) *Length of affordability.* IRUs must be maintained as affordable for a minimum term of ninety-nine (99) years.
  - (2) IRUs must be (i) functionally equivalent in construction and appearance to other dwelling units at the residential development; (ii) interspersed among other dwelling units at the residential development; (iii) proportionate to the number of bedrooms of the other dwelling units at the residential development; and (iv) compliant with all rules and regulations adopted by the director.
  - (3) IRUs in rental developments must be made affordable to and occupied by eligible households whose incomes are at or below the applicable AMI limit.
  - (4) IRUs in ownership developments must be made available for purchase at an affordable price to eligible households whose incomes are at or below the applicable AMI limit.
  - (5) The city may require an eligible household that purchases an IRU in an ownership development to record a performance deed of trust or a lien on the IRU.
  - (6) The AMI limit associated with each IRU will be identified as a part of the affordable housing plan and will remain subject to such limitation for the duration of the term of affordability.
- (g) *Rounding.* In calculating the number of on-site IRUs required pursuant this section, rounding shall be used such that five-tenths (0.5) or greater shall result in requiring that a whole unit shall be produced; provided, however, that at least one (1) unit shall be provided if the calculation results in less than five-tenths (0.5). By way of example, if a requirement is for 8.3 IRUs, the number of on-site IRUs would be eight (8). Alternatively, if a requirement is for 8.7 IRUs, the number of on-site IRUs would be nine (9).
- (h) *Effective average.* For applicants selecting to meet compliance options H-2B, T-2B, H-2E or T-2E, applicants may elect to serve eligible households earning eighty (80) percent or less of AMI for rental developments and