



# PROJECT MANUAL

**POND 001 EXPANSION**

**201737313**

## **PART I**

## **PROJECT REQUIREMENTS**

*Issued for Construction December 15, 2017*

CITY & COUNTY OF DENVER  
DEPARTMENT OF AVIATION



Department of Aviation  
Airport Office Building  
8500 Peña Boulevard  
Denver, Colorado  
(303) 342-2200  
www.flydenver.com



November 1, 2017

## **Pond 001 Expansion**

**CONTRACT NO. 201737313**

# **ADDENDUM NUMBER ONE**

This Addendum Number One supersedes and/or supplements all portions of the Contract Documents with which it conflicts. Bidders must acknowledge receipt of this addendum on page 28 of the Revised Bid Forms.

Zabel, Rick - DIA Digitally signed by Zabel, Rick - DIA  
DN: dc=com, dc=flydenver, dc=ad, ou=Domain  
Users, ou=Contractors, cn=Zabel, Rick - DIA,  
email=Rick.Zabel@flydenver.com  
Date: 2017.11.01 11:44:16 -0600

---

Rick Zabel, Project Manager



DENVER INTERNATIONAL AIRPORT

POND 001 EXPANSION

CONTRACT NO. 201737313

## ADDENDUM NUMBER ONE

### Scope of this Addendum

Addendum Number One includes modifications to the following Contract Documents issued October 13, 2017. These modifications are deemed necessary by the City and County of Denver.

### **PART ONE: VOL.1-CONTRACT DOCUMENTS**

#### **Page 1 Advertisement:**

The new date of Bid Opening is hereby Monday, November 6, 2017 at 2:00 p.m. local time

#### **IB-33 Schedule of Events:**

The new date of Bid Opening is hereby Monday, November 6, 2017 at 2:00 p.m. local time

### **PART TWO: DRAWINGS**

The drawings outlined herein are being re-issued or modified for bidding purposes as noted below.

SHEET #M1020      Modified per attached

SHEET #M1030      Modified per attached

The total number of pages (including cover sheet) contained in this Addendum Number One is four (4).

\* \* \* \* \*

*End of Addendum Number One*

**CITY AND COUNTY OF DENVER  
DEPARTMENT OF AVIATION  
DENVER INTERNATIONAL AIRPORT  
POND 001 EXPANSION  
NO. 201737313**

**Master Table of Contents**

|  |           |
|--|-----------|
| <b>INSTRUCTIONS TO BIDDERS</b> .....   | <b>3</b>  |
| <u>    </u> <b>IB-1 INSTRUCTIONS TO BIDDERS</b> .....  | <b>3</b>  |
| <b>IB-2 BIDDING</b> .....  | <b>3</b>  |
| <b>IB-3 COMPLETING AND SIGNING BID FORMS</b> .....   | <b>4</b>  |
| <b>IB-4 UNACCEPTABLE BIDS</b> .....  | <b>4</b>  |
| <b>IB-5 ONLY ONE BID ACCEPTED</b> .....  | <b>4</b>  |
| <b>IB-6 OPENING OF BIDS</b> .....  | <b>5</b>  |
| <b>IB-7 CONSIDERATION OF BIDS</b> .....  | <b>5</b>  |
| <b>IB-8 INFORMAL AND UNBALANCED BIDS</b> .....   | <b>5</b>  |
| <b>IB-9 BASIS FOR SELECTING THE APPARENT LOW BIDDER</b> .....  | <b>6</b>  |
| <b>IB-10 NOTICE TO APPARENT LOW BIDDER – EXECUTION OF CONTRACT</b> .....   | <b>6</b>  |
| <b>IB-11 CONFORMED TECHNICAL SPECIFICATIONS AND CONTRACT DOCUMENTS</b> .....   | <b>6</b>  |
| <b>IB-12 QUANTITIES IN THE BID FORM ENTITLED SCHEDULE OF PRICES AND</b><br><b>QUANTITIES (PART 2 OF THE BID FORMS)</b> ..... | <b>7</b>  |
| <b>IB-13 BID GUARANTEE; BONDS; INSURANCE</b> .....   | <b>7</b>  |
| <b>IB-14 RETURN OF BID GUARANTEE</b> .....   | <b>8</b>  |
| <b>IB-15 WEBSITE BULLETIN BOARD</b> .....  | <b>8</b>  |
| <b>IB-16 SITE INSPECTION AND INVESTIGATIONS</b> .....  | <b>8</b>  |
| <b>IB-17 INTERPRETATION OF BID DOCUMENTS</b> .....   | <b>9</b>  |
| <b>IB-18 MATERIALS AND SUBSTITUTIONS</b> .....   | <b>9</b>  |
| <b>IB-19 WITHDRAWAL OF BID</b> .....   | <b>10</b> |
| <b>IB-20 SUBCONTRACTOR LISTS IN BID</b> .....  | <b>10</b> |
| <b>IB-21 PERMIT FEES</b> .....   | <b>11</b> |
| <b>IB-22 TAXES</b> .....   | <b>11</b> |
| <b>IB-23 NONDISCRIMINATION IN THE AWARD OF CITY CONTRACTS</b> .....  | <b>11</b> |
| <b>IB-24 MINORITY BUSINESS ENTERPRISE AND WOMEN BUSINESS ENTERPRISE PARTICIPATION</b> .....                                  | <b>12</b> |
| <b>IB-25 DIVERSITY AND INCLUSIVENESS IN CITY SOLICITATIONS</b> .....   | <b>18</b> |
| <b>IB-26 WAGE RATE REQUIREMENTS</b> .....  | <b>18</b> |
| <b>IB-27 CONSTRUCTION SCHEDULING</b> .....   | <b>19</b> |
| <b>IB-28 EQUAL EMPLOYMENT OPPORTUNITY</b> .....  | <b>19</b> |
| <b>IB-29 CERTIFICATION REGARDING DEBARMENT, SUSPENSION, INELIGIBILITY AND VOLUNTARY</b><br><b>EXCLUSION</b> .....            | <b>20</b> |

|       |   |    |
|-------|---|----|
| IB-30 | INSURANCE REQUIREMENTS AND SAFETY MANUAL.....   | 20 |
| IB-31 | INVOICING .....   | 20 |
| IB-32 | PROJECT CONTROLS REQUIREMENTS .....   | 21 |
| IB-33 | SCHEDULE OF EVENTS .....  | 21 |
|       | PREVAILING WAGES .....  | 26 |
|       | NOTICE TO APPARENT LOW BIDDER.....  | 44 |
|       | CONTRACT .....  | 45 |
|       | PERFORMANCE BOND .....  | 46 |
|       | PAYMENT BOND .....  | 48 |
|       | NOTICE TO PROCEED.....  | 50 |
|       | CONSTRUCTION CONTRACT GENERAL CONDITIONS 2011 Edition .....   | 51 |
|       | SPECIAL CONDITIONS .....  | 57 |
| SC-1  | CONSTRUCTION CONTRACT GENERAL CONDITIONS .....  | 57 |
| SC-2  | DRAWINGS AND SPECIFICATIONS TO BE FURNISHED BY THE CITY.....  | 57 |
| SC-3  | REVISIONS TO G.C. 201.....  | 58 |
| SC-4  | CITY LINE OF AUTHORITY AND CONTACTS .....   | 58 |
| SC-5  | CONTRACTOR PERFORMANCE; SUBCONTRACTING .....  | 58 |
| SC-6  | COOPERATION WITH OTHERS.....  | 59 |
| SC-7  | PROSECUTION AND COMPLETION OF THE WORK: .....   | 59 |
| SC-8  | LIQUIDATED DAMAGES .....  | 59 |
| SC-9  | FACILITY SECURITY AND PERSONNEL ACCESS.....   | 60 |
| SC-10 | CONSTRUCTION ACCESS.....  | 62 |
| SC-11 | VEHICLE PERMITTING .....  | 62 |
| SC-12 | VENDORS AND SUPPLIERS .....   | 62 |
| SC-13 | COMMUNICATION DEVICES .....   | 62 |
| SC-14 | USE, POSSESSION OR SALE OF ALCOHOL OR DRUGS.....  | 62 |
| SC-15 | ATTORNEY'S FEES .....   | 63 |
| SC-16 | INSURANCE REQUIREMENTS .....  | 63 |
| SC-18 | ADDITIONAL AFFIRMATIVE ACTION REQUIREMENTS, FEDERAL PROVISIONS.....   | 64 |
| SC-19 | ESTIMATED QUANTITIES OF UNIT PRICED ITEMS .....   | 64 |
| SC-20 | REVISIONS TO G.C. 1102 .....  | 65 |
| SC-21 | LISTING OF ACCEPTABLE MANUFACTURERS.....  | 65 |
| SC-22 | ACCESSIBLE PARKING SPACES, ACCESS AISLES AND ROUTES OF TRAVEL.....  | 65 |
| SC-23 | SUBCONTRACTOR PAYMENTS AND SUBCONTRACTOR RELEASES – REQUIRED USE OF THE B2G CONTRACT MANAGEMENT SYSTEM..... | 66 |
| SC-24 | PAYMENTS TO CONTRACTORS.....  | 66 |
|       | INSURANCE CERTIFICATE OR REQUIREMENTS .....   | 68 |
|       | DENVER INTERNATIONAL AIRPORT .....  | 72 |
|       | FINAL LIEN RELEASE – CONSTRUCTION (Subcontractor).....  | 72 |
|       | PERTAINING TO EQUAL EMPLOYMENT OPPORTUNITY IN THE CITY AND COUNTY OF DENVER .....                           | 74 |
|       | EQUAL EMPLOYMENT OPPORTUNITY.....   | 75 |

|                     |    |
|---------------------|----|
| APPENDIX 1(A) ..... | 81 |
| APPENDIX 1(C) ..... | 83 |
| APPENDIX 1(D) ..... | 84 |
| APPENDIX 1(E).....  | 85 |
| APPENDIX 2 .....    | 87 |

**CITY AND COUNTY OF DENVER  
NOTICE OF INVITATION FOR BIDS  
CONTRACT NO. 201737313  
Pond 001 Expansion**

The Department of Aviation, City and County of Denver, has issued an Invitation for Bids for the construction project named above. Complete contract documents, including specifications, are available on the DEN Contract Procurement website at:

<http://business.flydenver.com/bizops/bids.asp>.

SEALED BIDS will be due, and must be time stamped, no later than 2:00 PM, Friday, November 3, 2017 Local Time, delivered in the triple wide trailer, located within the DEN South Campus at 7128 North Trussville Street, Unit A, Denver, CO 80249 (F.K.A. 27301 E. 71st Ave, Unit #2). Immediately after receipt of the bids a public bid opening will commence. Any bids to be submitted more than two hours prior to Bid Opening must be submitted at the office of Business Management Services, attention Tony Deconinck, Room 8810, Airport Office Building (AOB), Denver International Airport, 8500 Peña Blvd., Denver, CO 80249-6340.

**GENERAL STATEMENT OF WORK**

Construction of a new DIW (de-icing and industrial water) pond single cell system consisting of excavation, trenching for a 10.6 MG (million gallon) pond with associated liner, large diameter piping, diversion structure, piping & plumbing, mechanical, and electrical facilities. The project construction start date is projected January, 2018 start to procure long lead items for diversion structure and to finish prior to runway 7/25 shutdown during summer 2018.

**PREQUALIFICATION**

Each bidder must be pre-qualified in the category of 1.B Excavation and Grading, at the \$6,000,000.00 level, in accordance with the City's Rules and Regulations Governing Prequalification of Contractors. Each bidder must have submitted a prequalification application a minimum of ten (10) calendar days prior to the bid opening date. Prequalification applications must be submitted to the Department of Public Works, Prequalification Section, Dept. 614, 201 West Colfax Avenue, Denver, CO 80202. To view the Rules and Regulations and to obtain a prequalification application, please visit our website at [www.denvergov.org/prequalification](http://www.denvergov.org/prequalification), or call (720) 865-2539 for prequalification information ONLY.

**PRE-BID CONFERENCE**

A Pre-Bid Conference will be held at 3:00 PM, Friday, October 20, 2017, in the triple wide trailer, located within the DEN South Campus at 7128 North Trussville Street, Unit A, Denver, CO 80249 (F.K.A. 27301 E. 71st Ave, Unit #2). A site visit will be conducted immediately following the Pre-Bid Conference.

Any questions must be submitted in writing by email to [contract.procurement@flydenver.com](mailto:contract.procurement@flydenver.com), must have the words “Request for Clarification” and “Pond 001 Expansion, 201737313” in the email subject line, and must be received no later than ten (10) calendar days before the date and time set for receipt of Bids.

## **DISADVANTAGED BUSINESS ENTERPRISE PARTICIPATION**

**MINORITY/WOMEN BUSINESS ENTERPRISE GOAL:** Pursuant to Article III, Division 1 and 3 of Chapter 28 of the Denver Revised Municipal Code, the Project goal of **12% M/WBE** must be met with certified participants, or through the demonstration of a sufficient good faith effort. For compliance with good faith requirements, the M/WBE percentage solicitation level required for this project is 100%.

## **MISCELLANEOUS**

As its best interests may appear, the City and County of Denver reserves the right to reject any or all bids and to waive informalities in bids.

The work under the Contract is subject to minimum wage rates established by the City and County of Denver Career Service Board.

Publication Dates: October 13, 2017, October 16, 2017, October 17, 2017  
Published in The Daily Journal



**INSTRUCTION TO BIDDERS  
CITY AND COUNTY OF DENVER  
DEPARTMENT OF AVIATION**

**IB-1 INSTRUCTIONS TO BIDDERS**

These Instructions to Bidders are a part of the Contract Documents and are intended to serve as a guide to bidders. They are general in nature and may be amended or supplemented as needed to support any one specific invitation to bid. Each bidder shall prepare its bid in strict compliance with all requirements of the Contract Documents and by careful application of these instructions.

**IB-2 BIDDING**

The bound copy of these Contract Documents contains Bid Forms and Bid Data Forms. The bidder must complete these Bid Forms and submit them as its bid.

Each bid must be enclosed in a sealed envelope, addressed to the Chief Executive Officer (CEO), showing on the face of the envelope the name of the bidder, the project number, and descriptive title of the work for which the offer is made. The Notice of Invitation for Bids identifies where and when the bid must be delivered.

Addenda to the contract documents will be issued by publication in their entirety on the DEN Contract Procurement Website, <http://business.flydenver.com/bizops.asp>, from which each addendum document may be downloaded by planholders. Such addenda may include replacements for or additions to some or all of the pages of the Bid Forms, and all Bid Form pages added by addendum shall be submitted with the Bid Forms. Either a complete addendum or a notice of its issuance will be posted on the DEN Contract Procurement Website. Prior to submitting bids, Bidders shall read the DEN Contract Procurement website to confirm that they have received all addenda.

If Sensitive Security Information (“SSI”) will be provided to potential bidders prior to award of the Contract, each potential bidder shall be required to comply with Department of Aviation, Standard Policies and Procedures No. 6003, “Contractor Protection of Sensitive Security Information,” or its successor. A copy of this Policies and Procedures document will be provided with the Bid Documents, or upon request by the Department of Aviation, Business Management Services Office.

Each bidder shall submit the following, completed and executed in accordance with the Contract Documents:

- (1) the separately bound Bid Forms booklet;
- (2) all Bid Form pages not bound in such booklet which are included in any addendum to the Contract Documents;
- (3) the Bidder’s Bid Bond or Bid Guarantee in conformance with IB-13; and

- (4) the Bidder/Contractor Disclosure Form described in IB-29 and included with the Bid Forms, unless the Bidder has a current disclosure form on file with the City Clerk.

### **IB-3 COMPLETING AND SIGNING BID FORMS**

The bidder must complete the Bid Forms by legibly writing or printing in ink, words or figures, or both if required, all the bidder's offered prices for performing the work. All blank spaces which require a response of the bidder must be properly filled in. In filling out the Bid Forms, the bidder should avoid making changes to the extent possible, but, if changes are necessary, any interlineation, white outs, or erasures should be initialed.

For any contracts containing unit prices, the bidder shall specify in the Bid Forms a unit price for each item for which a quantity is given and shall write in figures the products of the respective unit prices and quantities in the "Amount" column provided for that purpose.

Each bidder must sign the Bid Forms and give the bidder's current business address. If an individual, the signature must be of the individual offering the bid; if a partnership, the signature must be that of a general partner; and if a joint venture, by each joint venture participant in their individual capacity as a corporation, partnership, or individual; if a corporation, both the president or a vice president and the secretary must sign and the seal of the corporation must be affixed. Signatures of other persons may be acceptable if the Bid contains evidence satisfactory to the CEO to prove that the other persons are authorized to bind the bidder.

### **IB-4 UNACCEPTABLE BIDS**

The City will not accept Bids from bidders in arrears to the City upon debt or contract, or which are defaulters (as surety or otherwise) upon any obligation to the City, or that are deemed irresponsible or unreliable by the CEO. A history or pattern of litigation against the City and County of Denver by any bidder, proposed subcontractor, interested party, or any person, firm, or corporation affiliated with any bidder, among other items, will be considered by the CEO in determining the responsibility and reliability of bidders. Bidders may be required to submit satisfactory evidence that they have a practical knowledge of the particular work bid upon and that they have the necessary financial resources to complete the proposed work.

### **IB-5 ONLY ONE BID ACCEPTED**

The City will accept only one Bid for the same work from any one bidder. This includes Bids that may be submitted under different names by one firm or corporation. Evidence of collusion among bidders shall be grounds for exclusion of any bidder who is a participant in any such collusion.

## **IB-6 OPENING OF BIDS**

Bidders are invited to be present at the bid opening which shall occur in the triple wide trailer, located within the DEN South Campus at 7128 North Trussville Street, Unit A, Denver, CO 80249 (F.K.A. 27301 E. 71st Ave, Unit #2) on the date set forth in the Notice of Invitation for Bids.

## **IB-7 CONSIDERATION OF BIDS**

After the Bids are opened and read and any discrepancies have been reviewed, bids will be compared based on the Total Contract Bid Amount written on page B-1 of the Bid Letter.

If a discrepancy exists between a price or amount written in words and the price or amount written in figures, the price or amount written in words shall govern, except that in the case where a price or amount shown in figures has been crossed out and replaced with a new, legible, initialed figure, the initialed figure shall govern.

Any bid discrepancies which the City corrects in accordance with the general rules described above shall be corrected with the understanding that the Apparent Low Bidder waives any claims against the City because of the bidder's mistakes in its bid.

The City reserves the right to waive informalities, to reject any and all bids, and to advertise for new bids where it is in the best interest of the City. The City also reserves the right to negotiate terms of the contract.

## **IB-8 INFORMAL AND UNBALANCED BIDS**

Bids shall be considered informal and may be rejected for the following reasons:

- (a) If the bid is on a form other than the Bid Forms furnished by the City, or if the form is altered or any part thereof is detached.
- (b) If there are unauthorized additions, conditional or alternate bids, or irregularities of any kind which may tend to make the bid incomplete, indefinite, or ambiguous.
- (c) If the bidder fails to acknowledge in the bid receipt of any or all addenda current on the date of opening of bids.
- (d) If the bid does not contain a unit price or lump sum amount for each item listed except in the case of authorized alternative items.
- (e) If there is an interlineation, white out, or erasure in the Bid Forms.
- (f) If the bid is unbalanced so that (1) each pay item does not reasonably carry its own proportion of cost, or (2) any pay item contains an inadequate or

unreasonable price.

**IB-9 BASIS FOR SELECTING THE APPARENT LOW BIDDER**

The selection of the Apparent Low Bidder will be made on the basis of the lowest responsive bid by a qualified bidder whose bid complies with all of the requirements prescribed herein. The lowest bidder shall be determined by the Total Base Bid Amount. This selection shall be subject to the approval of such resulting contract in accordance with the Charter and ordinances of the City and County of Denver.

If add alternates are listed in the Bid Documents, the Apparent Low Bidder will be chosen based solely on the lowest responsive Total Base Bid Amount.

**IB-10 NOTICE TO APPARENT LOW BIDDER – EXECUTION OF CONTRACT**

The Apparent Low Bidder will be given written notice of such status on the form included in the Bid Documents within ninety (90) days from the date of opening of bids.

The Apparent Low Bidder shall execute the contract and return it to the City along with the required bonds and insurance forms within ten (10) consecutive working days from and including the date of the Notice to Apparent Low Bidder. When the executed contract and the required bonds and insurance certificates are received, approval for the City to contract with the Apparent Low Bidder shall be sought in accordance with the Charter of the City and County of Denver. Such notice shall not create any rights in the Apparent Low Bidder to any contract with the City.

**IB-11 CONFORMED TECHNICAL SPECIFICATIONS AND CONTRACT DOCUMENTS**

The bidder understands that the City may elect, in its sole discretion, to deliver either one of the contract documents described below for execution.

- (a) A bound document containing the original Bid Documents and all of the prebid addenda, or
- (b) A bound document containing Part I of the original Bid Documents, the portions of the addenda which apply to Part I, and a single conformed set of Technical Specifications and Contract Documents which are produced by posting or otherwise incorporating in Part II of the original Bid Documents all of the changes to Part II which are described in the prebid addenda. If the City elects to prepare a conformed set of Technical Specifications and Contract Drawings, the following provision shall be incorporated in the Conformed Technical Specifications after the first page of its Table of Contents:

## **CONFORMED CONSTRUCTION DOCUMENTS**

The Technical Specifications and the Contract Drawings which were included in the Bid Documents, hereinafter referred to as the "Bid Document Specifications and Drawings," have been conformed by the City. The conformed Technical Specifications and Contract Drawings were prepared by posting or otherwise incorporating the changes noted in the prebid addenda into the Bid Document Specifications and Drawings to form a single set of construction documents. This set of construction documents is attached hereto and is hereinafter referred to in this document as the "Issued for Construction Documents."

The City's objective in preparing the Issued for Construction Documents is to produce a single set of documents which the Contractor and City will use during construction and which will facilitate the administration of the Contract. The city, however, recognizes that discrepancies between the Issued for Construction Documents and the prebid addenda could occur. Therefore, the Contractor and City agree that both parties shall have 90 days after a fully executed contract is delivered to the Contractor to identify any such discrepancies.

If the Contractor identifies any discrepancy, it shall describe it in a written notice delivered to the City's Project Manager within the 90-day period. If the City agrees that a discrepancy exists, the City shall correct the Issued for Construction Documents in accord with the written notice to assure that the Issued for Construction Documents accurately reflect and are consistent with the Bid Document Specifications and Drawings and changes thereto reflected in the prebid addenda.

If the City identifies a discrepancy, it shall describe it in a written notice delivered to the Contractor's Superintendent within the above-described 90-day period. The City shall, thereafter, correct the Issued for Construction Documents in accord with the written notice. If the Contractor disagrees with any City proposed correction or any City refusal to accept a Contractor proposed correction, the Contractor shall have the right to submit a Contractor Change Request and request a Change order in accordance with General Condition 1103.

During the 90-day period, the Bid Document Specifications and Drawings and the prebid addenda shall be part of the Contract Documents and are incorporated herein by this reference. After the 90-day period has elapsed, the parties (1) agree that the Issued for Construction Documents, as corrected pursuant to this provision, accurately reflect all of the changes to the Bid Document Specifications and Drawings contained in the addenda, and (2) agree that the Bid Document Specifications and Drawings and the portions of the prebid addenda which pertain thereto shall no longer be considered Contract Documents.

## **IB-12 QUANTITIES IN THE BID FORM ENTITLED SCHEDULE OF PRICES AND QUANTITIES (PART 2 OF THE BID FORMS)**

Except for items designated as Lump Sum, the quantities appearing in the Bid Forms are approximate only and are included for the purpose of comparing of bids.

Payment to the Contractor will be based on the actual quantities of work performed, measured, and accepted or materials furnished in accordance with the Contract Documents.

Any of the estimated quantities of work and materials shown in the Bid Forms may each be increased, decreased, or omitted as provided in the General Conditions, Special Conditions, or Technical Specifications.

## **IB-13 BID GUARANTEE; BONDS; INSURANCE**

As a guarantee of good faith on the part of the bidder, each Bid must be accompanied by a Bid guarantee consisting of either a certified or cashier's check made payable without condition to the order of the City and County of Denver or a bid bond written by an approved corporation surety in favor of the City and County of Denver. If the Bid of a bidder is acceptable and the bidder is notified by the CEO that it is considered to be the Apparent Low Bidder and said bidder fails to (1) execute a contract in the form

prescribed, (2) furnish the payment and performance bonds described in Title 15 of the General Conditions, (3) furnish the required evidence of insurance described in Title 16 of the General Conditions or in the Special Conditions, or (4) satisfy any other condition precedent to contract execution within its power within five (5) working days after such notice is made by the City, said bid guarantee shall be forfeited to the City as liquidated damages and not as a penalty. The bid guarantee shall be in the amount of five percent (5%) of the Total Contract Bid Amount written in the Bid Letter of the Bid Forms. A Bid Bond form for execution by the bidder is supplied with each set of contract documents. IF A BID BOND IS USED, IT MUST BE THE FORM OF BID BOND SUPPLIED WITH THE CONTRACT DOCUMENTS.

#### **IB-14 RETURN OF BID GUARANTEE**

As soon as bid prices have been compared, bid guarantees of all except the three lowest bidders will be returned. When the Apparent Low Bidder executes the contract and delivers to the City satisfactory performance and payment bonds and required insurance documentation, and any other conditions precedent to contract execution by the City have been satisfied, including, where applicable, City Council contract approval, the bid guarantees of the three lowest bidders shall be returned to them.

#### **IB-15 WEBSITE BULLETIN BOARD**

It shall be conclusively presumed that the Bidder did, before submitting a bid, read all addenda, posted decisions, and other information items relevant to the Bid which appeared on the DEN Contract Procurement website at <http://business.flydenver.com/bizops.asp>.

#### **IB-16 SITE INSPECTION AND INVESTIGATIONS**

Prior to submitting an offer, the bidder shall inspect the work site and its surroundings. A site visit will be undertaken following the pre-bid conference. Requests for additional site visits must be made at least ten (10) calendar days prior to the bid opening and such visits must be requested in a letter sent to email to [contract.procurement@flydenver.com](mailto:contract.procurement@flydenver.com). For purposes of the contract, it shall be conclusively presumed that the bidder has made a thorough inspection of the site and has waived the right to later claim extra payment or time extensions for conditions which would have been evident during that inspection.

Drawings and specifications, defining the work to be done, were prepared on the basis of interpretation by design professionals of information derived from investigations of the work site and site condition data provided by the City. Such information and data are subject to sampling errors, and the interpretation of the information and data depends to a degree on the judgment of the design professional. In view of this, the bidder is invited to make additional investigations as the bidder's judgment dictates the need for such investigations. If the bidder desires to perform site investigations, it shall request in writing the right to do so. This request shall be sent to email to [contract.procurement@flydenver.com](mailto:contract.procurement@flydenver.com).

Because the bid information cannot be guaranteed, the Contractor shall have assumed the risks attendant to successful performance of the work except for the risk of encountering differing site conditions which are defined in the General Conditions and shall never make claim for additional payments or time extensions on the grounds that the nature or amount of work to be done was not understood by the bidder at the time of bidding.

#### **IB-17 INTERPRETATION OF BID DOCUMENTS**

During the Bid period, Bidder shall request, in writing, clarification or interpretation of any apparent errors or omissions in the contract documents, any apparent inconsistencies between different provisions of the contract documents, or any other point in the contract documents which the Bidder believes requires clarification or interpretation by the City. Any such request must be submitted in writing by email to [contract.procurement@flydenver.com](mailto:contract.procurement@flydenver.com), must have the words "Request for Clarification" and "Pond 001 Expansion, 201737313" in the email subject line, and must be received not later than ten (10) calendar days before the date and time set for receipt of Bids. For purposes of the contract, it shall be conclusively presumed that prior to bidding, the Bidder requested clarification or interpretation of any apparent errors, inconsistencies, or other point in the contract documents believed to require clarification or interpretation, and has waived the right to later claim extra payment or time extensions on account of any such error, omission, inconsistency, or other matter in the contract documents.

Information about any interpretation or clarification made by the City in response to such request will be posted on the DEN Contract Procurement website, <http://business.flydenver.com/bizops/bids.asp>. It shall be the Bidder's responsibility to ensure it has reviewed all such interpretations or clarifications. After Bids are opened, all Bidders must abide by the decision of the CEO or his authorized representative as to the interpretation or clarification. If the CEO or his authorized representative determines that his decision or interpretation requires that an addendum to the Bid documents be issued, such addendum will be posted on the DEN Contract Procurement website. It shall be the Bidder's responsibility to ensure it has received all such addenda, and each Bidder must acknowledge receipt of all addenda on the Bid Forms when it submits its Bid.

The City shall not be bound by and the Bidder shall not rely on any oral interpretation or clarification of the Bid Documents.

#### **IB-18 MATERIALS AND SUBSTITUTIONS**

It is often convenient and practical to specify materials and equipment to be incorporated into the work by a proprietary name or by the name of its manufacturer. When so specified and further qualified by the phrases "or equal" or "or equivalent," it shall be understood that such specification is not intended to limit the material and equipment selection process. Rather, the specification is intended to indicate a standard

of quality and capability which will be accepted. However, all bidders desiring to use materials other than the specified material must obtain the written approval of the Project Manager. Any such request must be submitted in writing by email to [contract.procurement@flydenver.com](mailto:contract.procurement@flydenver.com), must have the words "Request for Substitution" and "Pond 001 Expansion, 201737313" in the email subject line, and must be received no later than ten (10) calendar days before the date and time set for opening of bids so that all such approvals will be included in addenda to ensure full and complete disclosure to all potential bidders of all approved equal or equivalent materials. All requests for approval of equal or equivalent material shall contain adequate technical data to clearly demonstrate equivalency. Incomplete submittals will not be reviewed. Requests must be submitted on the attached form titled "Request for 'or equal' Approval." Requests containing inadequate or incomplete information will not be considered.

If the bidder is awarded the contract and elects to use an "OR EQUAL" which has been added by addendum, the bidder shall be deemed to have warranted that;

- (a) the use of the "OR EQUAL" fulfills the specification requirements contained in the Contract Documents.
- (b) the installation of the "OR EQUAL" will not impact the spatial requirements for the Work or the scheduling of work performed by the City or other contractors.

Additionally, the bidder agrees that it shall modify any building system(s) (HVAC, structural, electrical, etc.) impacted by the use of an "OR EQUAL" at no cost to the City or other contractors under contract with the City and shall make no claims for delay or disruption arising out of such modification.

#### **IB-19 WITHDRAWAL OF BID**

A bidder may withdraw its Bid at any time prior to the time for opening of bids set forth in the Notice of Invitation for Bids by making written request to the CEO. After the expiration of the bid period, no bid can be withdrawn for one hundred twenty (120) calendar days after the date bids are opened or until after a contract for the work described in these Bid Documents is fully executed by the City, whichever date is earlier.

Such a request must be signed by persons authorized to bind the bidder as defined in IB-3, "Completing and Signing Bid Forms."

#### **IB-20 SUBCONTRACTOR LISTS IN BID**

The bidder shall, on the forms included in the Bid Forms, identify each element of the work which the bidder plans to subcontract, provide an estimate of the total cost to perform each element, and include the name and address of the proposed subcontractor.



## **IB-21 PERMIT FEES**

The Contractor agrees to pay the permit fees associated with the construction of this project described in General Condition 317, and in the Special Conditions and Technical Specifications.

## **IB-22 TAXES**

1. General. Bidders are referred to the General Conditions, G.C. 323, as to taxes to which they may be subject in performing the Work under this contract, including but not limited to sales and use taxes and the Denver Occupational Privilege Tax. The following instructions are to be considered along with the General Conditions and not in lieu of them.
2. Sales and Use Tax. Construction and building materials sold to contractors and subcontractors for use on structures, roads, streets, highways, and other public works owned by the City and County of Denver at Denver International Airport are exempt from state, RTD, and Cultural Facilities District sales and use taxes. However, such materials will be subject to sales and use taxes imposed by the City and County of Denver.
3. Exemption Certificates – Sales and Use Tax. It is responsibility of the Contractor and its subcontractors to apply to the Colorado Department of Revenue (“CDOR”) for a certificate, or certificates, of exemption indicating that their purchase of construction or building materials is for a public project, and to deliver to the City copies of such applications as soon as possible after approval by the CDOR. Bidders shall not include in their bid amounts the exempt State, RTD, and Cultural Facilities District Sales and Use Taxes.
4. Denver Occupational Privilege Tax. Any employee working for a contractor or a subcontractor who earns over \$500 working in Denver during a calendar month is subject to the payment of the Employee Occupational Privilege Tax. The Contractor and any subcontractor must pay the Business Occupational Privilege Tax for each of its employees who are subject to such tax.

## **IB-23 NONDISCRIMINATION IN THE AWARD OF CITY CONTRACTS**

It is the policy of the City and County of Denver to prohibit discrimination in the award of construction contracts and subcontracts for public improvements. Further, the City and County of Denver encourages contractors to utilize minority and women owned businesses and to divide the construction work into economically feasible units or segments to allow the most opportunity for subcontracting.

## **IB-24 MINORITY BUSINESS ENTERPRISE AND WOMEN BUSINESS ENTERPRISE PARTICIPATION**

Divisions 1 and 3, Article III of Chapter 28 of the Denver Revised Municipal Code (Sections 28-31 to 28-36 and 28-52 to 28-90, D.R.M.C.) (the "Ordinance") apply to this Project and are incorporated into this Contract by reference. Generally, the Ordinance provides for the adoption of a good faith goals program, to be administered by the Division of Small Business Opportunity (DSBO), devised to provide increased opportunities for Minority/Women Business Enterprises (MBE/WBEs). As such, each proposer must comply with the terms and conditions of the Ordinance in making its bid and, if awarded the Contract, in performing all Work thereunder. A proposer's failure to comply with the Ordinance, any Rules or Regulations promulgated pursuant thereto, or any additional requirement contained herein shall render the bid non-responsive and shall constitute cause for rejection. Failure by the contractor awarded the contract to comply with Ordinance requirements during the performance of the contract is a material breach of the contract, which may result in the termination of this contract, the imposition of sanctions or such other remedy, as deemed appropriate by DSBO. Copies of the Ordinance and its accompanying Rules and Regulations are available for the use and review of proposers from DSBO.

In order to comply with the bid requirements of the Ordinance, a proposer shall either meet the established project goal or, in the alternative, demonstrate that the proposer has made sufficient good faith efforts to meet the goal in accordance with the Ordinance. In preparing a bid to meet the established Project goal, proposers should consider the following instructions relating to compliance with the Ordinance:

1. Under the Ordinance, the Director of DSBO ("Director") is directed to establish project goals for expenditures on construction, reconstruction and remodeling work performed for the City and County of Denver. The specific goal for this project is stated in the Notice of Invitation for Proposers bound herein.
2. In preparing its bid, each proposer shall list on the Bid Form pages entitled "List of Proposed Minority/Women Business Enterprise Proposers, Subcontractors, Suppliers, Manufacturers, Manufacturers' Representatives or Brokers" the name, address, work description/supply, committed level of participation and other required information for each MBE/WBE of any tier which the proposer intends to use in performing the work on this Project. **Only the MBE/WBEs identified and the precise levels of participation listed for each on the Bid Form page, at the time of bid opening, will be considered in determining whether the proposer has met the designated participation goal. Additional, revised or corrected participation submitted after bid opening will not be considered. MBE/WBE proposers may count self-performance or joint venture activity in meeting the MBE/WBE project goal, but only for the scope of work performed as a commercially useful function and at a percentage level the MBE/WBE will be performing itself.**
3. All MBE/WBEs listed on the Bid Form must be properly certified by the City on or before the date bids are opened in order to count towards meeting the designated goal.

DSBO maintains an MBE/WBE Construction Directory ("Directory"), which is a current listing of MBE/WBEs that have been certified by the City. A copy of the Directory is available from the DSBO Directory Web site at [www.denvergov.org/DSBO](http://www.denvergov.org/DSBO). Proposers are encouraged to use the Directory to assist in locating MBE/WBEs for the work and supplies required on the Project. Proposers are reminded that changes may be made to the Directory at any time in accordance with the City's MBE/WBE Ordinance and procedures established to administer this program, and that a current copy of the Directory must always be used in preparing a bid. MBE/WBE certification or listing in the Directory is not a representation or warranty by the City as to the qualifications of any listed MBE/WBE.

4. In accordance with the provisions of the Ordinance, DSBO will evaluate each bid to determine the responsiveness of the bid to the requirements of the Ordinance. In determining whether a proposer's committed level of participation meets or exceeds the stated MBE/WBE goal, DSBO shall base its calculation of applicable amounts and percentages on the total base bid amount, not including any listed alternates, of each bid as follows:
  - a. The bid information provided by the agency will be used to determine the total base bid amount of each bid. Each proposer's total base bid amount will be multiplied by the MBE/WBE percentage established for the project to determine the exact dollar amount of required MBE/WBE participation for the Project. This amount will then be compared against the exact dollar amounts for the MBE/WBEs committed for participation by the proposer. If the total dollar amount of participation listed meets or exceeds the established MBE/WBE dollar amount goal listed, then DSBO will determine that the goal has been met.
  - b. In addition, DSBO will determine the exact commitment percentage for each listed MBE/WBE by dividing the dollar amount listed for each MBE/WBE by the total base bid dollar amount submitted by the proposer. These individual percentages, when totaled for all listed MBE/WBEs, will establish the total committed percentage level of MBE/WBE participation that the proposer must comply with during the life of the contract. In all cases, the committed percentage level of MBE/WBE participation must equal or exceed the assigned MBE/WBE goal for the Project.
  - c. In providing the exact dollar amount of participation for each listed MBE/WBE, a proposer should take care never to round up in determining whether or not the total of these amounts meets or exceeds the established percentage goal. The goal must be met or exceeded by dollar amounts and percentages in order for DSBO to determine that the proposer has met or exceeded the applicable MBE/WBE goal.
  - d. As previously mentioned, compliance with the MBE/WBE goal will be determined on the base bid alone. If a bid contains alternates, participation contained in any alternate will not count towards satisfaction of the Project goal.

However, should any designated alternate be selected by the City for inclusion in the contract ultimately awarded, the MBE/WBE goal percentage level submitted at bid time, on the base bid, will also apply to the selected alternates and must be maintained for the life of the contract on the total contract amount, including any alternate work. Thus, even though such participation will not be considered in evaluating bids, proposers are urged to consider participation in preparing bids for designated alternates.

- e. On projects where force account or allowance bid items have been included, proposers must meet the MBE/WBE goal percentage based upon the total base bid, including all such items that are submitted to the City. However, when a force account or allowance is designated by the City to be either performed or purchased from a specific company, the proposer may back out the dollar amount of the force account or allowance from the total base bid and meet the MBE/WBE goal on the remaining reduced amount.
  - f. **On bids that, at the time of bid opening, are equal to or exceed Five Million Dollars (\$5,000,000.00), including any alternates that may be selected, only sixty percent (60%) of the value of the commercially useful function performed by MBE/WBE suppliers shall count toward satisfaction of the Project goal. On Projects under Five Million Dollars (\$5,000,000.00) the value of the commercially useful function of MBE/WBE supplier(s) will count at a one hundred percent (100%) level. Manufacturers' representatives and packagers shall be counted in the same manner as brokers.**
  - g. **In utilizing the MBE/WBE participation of a Broker,** only the bona fide commissions earned by such Broker for its performance of a commercially useful function will count toward meeting the Project goals. The proposer must separate the bona fide brokerage commissions from the actual cost of the supplies or materials provided to determine the actual dollar amount of participation that can be counted towards meeting the goal.
5. On or before the third (3<sup>rd</sup>) working day after bid opening, all of the Proposers are required to submit an executed "MBE/WBE Letter of Intent" for each MBE/WBE listed on the Bid Form as a joint venture member, subcontractor, supplier, manufacturer, manufacturers' representative or broker of any tier. An MBE/WBE Proposer needs to submit a Letter of Intent for any portion of self-performed work to count towards MBE/WBE utilization. Each Letter of Intent shall be submitted only for the MBE/WBEs listed at the time of bid opening, since this is the only participation that will be counted toward satisfaction of the project goal. A form for the MBE/WBE Letter of Intent is included with the Bid Form. The MBE/WBE Letter of Intent is a written communication from the Proposer to the City evidencing an understanding that the Proposer has or will enter into a contractual relationship with the MBE/WBE or that its subcontractor(s) and supplier(s), manufacturer(s), manufacturers' representative(s) and broker(s) will do so. Each MBE/WBE Letter of Intent shall be

accompanied by a copy of the City and County of Denver's MBE/WBE certification letter for each proposed MBE/WBE identified at bid time. Proposers are urged to carefully review these Letters before submission to the City to ensure that they are properly completed and executed by the appropriate parties.

In preparing a bid to demonstrate a good faith effort, proposers should consider the following instructions relating to compliance with the Ordinance:

1. If any Proposer has not met the designated Project goal at the time the bids are opened or elects to present a good faith effort in lieu of or in addition to attempting to satisfy the designated Project goal, that Proposer shall submit, on or before the third (3<sup>rd</sup>) working day after the bid opening a detailed statement, with supporting documentation, setting forth its good faith efforts, made prior to bid opening, attempting to meet the established goal in accordance with Section 28-62 of the Ordinance. This statement shall address each of the items in Subsection (b) of that Section and any additional criteria that the DSBO Director may establish by rule or regulation. A Proposer who fails to meet the Project goal and cannot show that it made a good faith effort to meet the goal shall be considered non-responsive.
2. The statement of good faith efforts shall include a specific response to each of the following as further defined by rule or regulation. A Proposer may include any additional information the Proposer believes may be relevant. Failure of a Proposer to show good faith efforts as to any one of the following items shall render its overall good faith showing insufficient and its bid non-responsive. Items (1) through (9) of Section 28-62, Subsection (b) of the Ordinance are set forth below:
  - (1) The proposer or proposer must solicit through all reasonable and available means, the interest of all MBEs and WBEs certified in the scopes of work of the contract. The proposer or proposer must solicit the interest of such MBEs and WBEs within sufficient time, prior to the bid opening or date of final project-specific bid in the case of a competitive selection process, to allow such MBEs and WBEs to respond to the solicitation. The proposer or proposer must determine with certainty if the MBEs and WBEs are interested by demonstrating appropriate steps to follow up initial solicitations.
  - (2) The proposer or proposer must select portions of the work of the contract to be performed by MBEs and WBEs in order to increase the likelihood that the project goal will be achieved. This includes, where appropriate, breaking out contract work items into economically feasible units to facilitate MBE and WBE participation as subcontractors or joint ventures, and for proposer or proposer self-performed work, as suppliers, manufacturers, manufacturer's representatives and brokers, all reasonably consistent with industry practice, even when the proposer or proposer would otherwise prefer to perform these work items with its own forces. The proposer or proposer must identify what portions of the contract will be self-performed and what portions of the contract will be opened to solicitation of bids, bids and quotes from MBE and WBEs. All portions of the contract not self-performed must be solicited for MBE and WBE

participation. The ability or desire of a proposer or proposer to perform the work of a contract with its own forces does not relieve the proposer or proposer of the responsibility to meet the project goal or demonstrate good faith efforts to do so.

- (3) The proposer or proposer, consistent with industry practice, must provide MBEs and WBEs at a clearly stated location with timely, adequate access to and information about the plans, specifications, and requirements of the contract, including bonding and insurance requirements, if any, to assist them in responding to a solicitation.
- (4) The proposer or proposer must negotiate in good faith with interested MBEs and WBEs and provide written documentation of such negotiation with each such MBE or WBE.
- (5) For each MBE or WBE which contacted the proposer or proposer or which the proposer or proposer contacted or attempted to subcontract or joint venture with, consistent with industry practice, the proposer or proposer must supply a statement giving the reasons why the proposer or proposer and the MBE or WBE did not succeed in negotiating a subcontracting, supplier, manufacturer, manufacturer's representative, broker or joint venture agreement, as applicable.
- (6) The proposer or proposer must provide verification that it rejected each non-utilized MBE and WBE because the MBE or WBE did not submit the lowest bid or it was not qualified. Such verification shall include a verified statement of the amounts of all bids received from potential or utilized subcontractors, suppliers, manufacturers, manufacturer's representatives, brokers or joint ventures on the contract, whether or not they are MBEs or WBEs. In making such a determination of not being qualified, the proposer or proposer shall be guided by the definition of qualified in section 28-54(42), but evidence of lack of qualification must be based on factors other than solely the amount of the MBEs or WBEs bid. For each MBE or WBE found not to be qualified by the proposer or proposer, the verification shall include a statement giving the proposer's or proposer's reasons for its conclusion. A proposer's or proposer's industry standing or group memberships may not be the cause of rejection of an MBE or WBE. A proposer or proposer may not reject an MBE or WBE as being unqualified without sound reasons based on a reasonably thorough investigation and assessment of the MBEs or WBEs capabilities and expertise.
- (7) If requested by a solicited MBE or WBE, the proposer or proposer must make reasonable efforts to assist interested MBEs and WBEs in obtaining bonding, lines of credit, or insurance as required by the City or by the proposer or proposer, provided that the proposer or proposer need not provide financial assistance toward this effort.
- (8) If requested by a solicited MBE or WBE, the proposer or proposer must make reasonable efforts to assist interested MBEs and WBEs in obtaining necessary and competitively priced equipment, supplies, materials, or related assistance or services for performance under the contract, provided that the proposer or proposer need not provide financial assistance toward this effort.
- (9) The proposer or proposer must use the DSBO MBE/WBE directories to identify, recruit, and place MBEs and WBEs.

In accordance with the provisions of the Ordinance, the proposer agrees that it is committed to meeting either the MBE/WBE participation goal or the MBE/WBE participation set forth in its statement of good faith efforts. This commitment must be expressly indicated on the "Commitment to Minority/Women Business Enterprise Participation" form included with the Bid Form. This commitment includes the following understandings:

1. The proposer understands it must maintain MBE/WBE goals throughout the performance of the Contract pursuant to the requirements set out in D.R.M.C. 28-72.
2. The proposer understands that it must establish and maintain records and submit regular reports, as required, that will allow the City to assess progress in achieving the MBE/WBE participation goal.
3. **The proposer understands that if change orders or any other contract modifications are issued under the contract, the proposer shall have a continuing obligation to immediately inform DSBO in writing of any agreed upon increase or decrease in the scope of work of such contract, upon any of the bases discussed in Section 28-73 of the Ordinance, regardless of whether such increase or decrease in scope of work has been reduced to writing at the time of notification.**
4. The proposer understands that if change orders or other contract modifications are issued under the contract, that include an increase in scope of work of a contract for construction, reconstruction, or remodeling, whether by amendment, change order, force account or otherwise which increases the dollar value of the contract, whether or not such change is within the scope of work designated for performance by an MBE/WBE at the time of contract award, such change orders or contract modification shall be immediately submitted to DSBO for notification purposes. Those amendments, change orders, force accounts or other contract modifications that involve a changed scope of work that cannot be performed by existing project subcontractors or by the contractor shall be subject to a goal for MBE/WBEs equal to the original goal on the contract which was included in the bid. The contractor shall satisfy such goal with respect to such changed scope of work by soliciting new MBE/WBEs in accordance with Section 28-73 of the Ordinance as applicable, or the contractor must show each element of modified good faith set out in Section 28-75 (c) of the Ordinance. The contractor or consultant shall supply to the director the documentation described in Section 28-75 (c) of the Ordinance with respect to the increased dollar value of the contract.

All proposers are charged with knowledge of and are solely responsible for complying with each and every provision of the Ordinance in making a bid and, if awarded, in performing the work described in the Contract Documents. Failure to comply with these provisions could constitute cause for rejection of a bid or subject the selected contractor to sanctions set forth in the Ordinance. These instructions are intended only to generally assist the proposer in preparing and submitting a compliant bid. Should any questions arise regarding specific circumstances, proposers must consult the Ordinance or contact the Project's designated DSBO representative at (303) 342-2180.

## **IB-25 DIVERSITY AND INCLUSIVENESS IN CITY SOLICITATIONS**

Each bidder shall, as a condition of responsiveness to this solicitation, complete and return the “Diversity and Inclusiveness in City Solicitations Information Request Form” with their Bid.

Using the “Diversity and Inclusiveness in City Solicitations Information Request Form” please state whether you have a diversity and inclusiveness program for employment and retention, procurement and supply chain activities, or customer service and provide the additional information requested on the form. The information provided on the “Diversity and Inclusiveness in City Solicitations Information Request Form” will provide an opportunity for City contractors to describe their own diversity and inclusiveness practices. Contractors are not expected to conduct intrusive examinations of its employees, managers, or business partners in order to describe diversity and inclusiveness measures. Rather, the City simply seeks a description of the contractor’s current practices, if any.

Diversity and Inclusiveness information provided by City contractors in response to City solicitations for services or goods will be collated, analyzed, and made available in reports consistent with City Executive Order No. 101. However, no personally identifiable provided by or obtained from contractor’s will be in such reports.

In order for the agency or City to consider the bid or proposal, Contractors must complete the electronic version of the Diversity And Inclusiveness In City Solicitations Form then **print the completed form and include the hard copy as part of its bid documents. A proposal or response to a solicitation by a contractor/consultant that does not include this completed form shall be deemed non-responsive and rejected.** The form is found at: <https://fs7.formsite.com/CCDenver/form161/index.html>

The Diversity and Inclusiveness form is separate from the requirements established by DSBO, and must always be completed regardless of whether or not there are any goals assigned to the project.

## **IB-26 WAGE RATE REQUIREMENTS**

Pursuant to Section 20-76 of the Revised Municipal Code, the bidder selected to perform this contract shall pay mechanics, laborers and workers employed directly upon the site of the work the full amounts accrued at the time of payment, computed wage rates not less than those shown on the current prevailing wage rate schedule included in the contract bid documents and any addenda thereto. If the City’s Career Service Board issues a modification to those wage rates more than ten (10) days prior to the scheduled bid opening, those modifications will be published in an addendum issued by the City to all prospective bidders. The City may, in its sole discretion, determine on a case-by-case basis whether wage rate modifications issued by the Career Service Board ten (10) days or less before the bid opening will be included in an addendum. If they are included in an addendum, the City may, in its sole discretion, elect to postpone the date of bid opening.



If the term of the contract extends for more than one year, the minimum City prevailing wage rates that contractors and subcontractors shall pay during any subsequent yearly period or portion thereof shall be the wage rates in effect on the yearly anniversary date of the contract which begins such subsequent period. In no event shall any increases in prevailing wages after the first anniversary of the contract result in any increased liability on the part of the City and the possibility and risk of any such increase is assumed by all contractors entering into such contract with the City.

#### **IB-27 CONSTRUCTION SCHEDULING**

The bidder should refer to the General Conditions, Special Conditions, and Division I of the Technical Specifications for scheduling requirements for this contract.

#### **IB-28 EQUAL EMPLOYMENT OPPORTUNITY**

1. Article III, Division 2 of Chapter 28 applies to this contract. It is the policy of the City to provide equal opportunity in employment without regard to race, color, creed, sex, national origin, religion, marital status, or political opinion or affiliation. It is hereby deemed and declared to be for the public welfare and in the best interest of the City to require bidders, contractors and subcontractors soliciting and receiving, directly or indirectly, compensation from or through the City, for the performance of such contracts, to meet certain affirmative action and equal employment opportunity requirements. Additionally, contractors and subcontractors that hold any contracts which are federally-assisted shall be required to adhere to the Department of Labor's Contract Compliance program under Executive Order 11246 as defined in the regulations of the Secretary of Labor at 41 CFR Chapter 60-4.
2. After the Notice to Apparent Low Bidder has been issued, the Apparent Low Bidder shall submit the following to the Division of Small Business Opportunity:
  - (a) A statement that the bidder shall implement the affirmative action steps set forth in the Rules and Regulations and Bid Conditions of the Manager of Public Works pertaining to Equal Employment Opportunity, attached hereto, or the bidder's affirmative action plan which meets these requirements, and
  - (b) A projection of its anticipated workforce for this contract on the attached "EEO Questionnaire." Both of these submittals are required before the Division of Small Business Opportunity will approve the Notice to Proceed.
3. The bidder which is awarded this contract shall comply with the provisions and requirements, including the goals of minority and female participation and specific affirmative action steps, set forth in the Rules and Regulations and Bid Conditions of the Manager of Public Works pertaining to Equal Employment Opportunity, as said rules and regulations may be amended or readopted from time to time by the

Manager of Public Works or the Director of the Division of Small Business Opportunity.

### **IB-29 CERTIFICATION REGARDING DEBARMENT, SUSPENSION, INELIGIBILITY AND VOLUNTARY EXCLUSION**

The bidder certifies, by submission of its bid or acceptance of this contract, that neither it nor its principals is presently debarred, suspended, proposed for debarment, declared ineligible, or involuntarily excluded from participation in any government contract by any Federal, State, or local government department or agency. It further agrees by submitting its bid that it will include this clause without modification in all lower tier transactions, solicitations, proposals, contracts, and subcontracts. Where the bidder or any lower tier participant is unable to certify to this statement, it shall attach an explanation to its bid.

### **IB-30 INSURANCE REQUIREMENTS AND SAFETY MANUAL**

In preparing its Bid, the Bidders shall assure that insurance requirements contained in the Contract Documents are met. In accordance with the provisions of General Contract Condition 1601, INSURANCE, the minimum insurance requirements for this Contract are set forth in the form **CITY AND COUNTY OF DENVER INSURANCE CERTIFICATE** contained in the Special Conditions Section of the Contract Documents. Bidders are urged to consider in preparing a bid hereunder that the Contractor and all subcontractors performing Work on the Project must comply with each condition, requirement or specification set forth in the form certificate, unless such requirements are specifically excepted in writing by the City's Risk Management Administrator. The Contractor must either include all subcontractors performing work hereunder as insureds under each required policy or furnish a separate certificate (on the form certificate provided) for each subcontractor.

City will provide a Rolling Owner Controlled Insurance Program (ROCIP), which coverage City agrees will be primary over any other insurance provided by an enrolled party. A copy of the ROCIP proposed coverage and Safety Manual are included in the Contract Documents. Bidder should review the proposed coverage and Safety Manual in preparing its bid.

### **IB-31 INVOICING**

The Contractor recognizes and agrees that it shall be required to use the Textura® Construction Payment Management System (CPM System) for this Project. All fees associated with the CPM System are to be paid by the Contractor prior to billings for any work performed (the "Textura Fee"). **The Textura fee shall not be included as a line item in the Contractors bid.**

During the negotiation phase the City will work with Textura to calculate the Textura fee as a percentage of the sub-total of all other line items. The City will provide the Textura Fee amount to the Contractor, who will then pay this amount to Textura

directly. The Textura Fee should be included on a Contractors pay application to the City and the City will reimburse the Contractor as a pass through expense for the Textura Fee with no mark-up.

The attached Textura Fee Schedule, included in the bid documents, is only to be used as a reference.

**IB-32 PROJECT CONTROLS REQUIREMENTS**

The Contractor will be required to use the designated Project Management Information System (PMIS) as set forth in the Technical Specifications. The PMIS is Airport Infrastructure Management’s tool for project and information management, data analysis and document control. Denver International Airport will be responsible for providing the licensing and training for PMIS.

**IB-33 SCHEDULE OF EVENTS**

This projected schedule is an estimated timeline and is subject to change at the sole discretion of the City.

| Event                         | Date                      |
|-------------------------------|---------------------------|
| Bid Issued                    | October 13, 2017          |
| Pre-Proposal Conference       | October 20, 2017, 3:00 PM |
| Last Date to Submit Questions | October 27, 2017, 5:00 PM |
| Proposal Due Date             | November 3, 2017, 2:00 PM |

**REQUEST FOR “OR EQUAL” APPROVAL**

|               |                    |
|---------------|--------------------|
| Contract No.: | 201737313          |
| Title:        | Pond 001 Expansion |

This request, **in duplicate**, must be received by the of Business Management Services, Tony Deconinck, Room 8810, Airport Office Building (AOB), Denver International Airport, 8500 Peña Blvd., Denver, CO 80249-6340, or at [contract.procurement@flydenver.com](mailto:contract.procurement@flydenver.com), by noon at least 10 days prior to bid date.

**To be completed and signed by requesting party:**

|  |  |
|--|--|
| Specification Section/Drawing Number:                          | Page No./Paragraph No./Subparagraph No.: |
| Specified Product:   | Specified Manufacturer:                  |
|  | Specified Model No.:                     |
| “Or Equal” Product:  | “Or Equal” Manufacturer:                 |
|  | “Or Equal” Model No.                     |
| Reason for “Or Equal” substitution:                            |  |
| Prior Applications [Installations of at least 3 years length]: |  |
| (1) Project: _____   | Date: _____                              |
| (2) Project: _____   | Date: _____                              |
| (3) Project: _____   | Date: _____                              |

**General product literature/catalog cuts/drawings or other appropriate information detailing the “Or Equal” product with respect to the project specifications must be attached to this form for approval.**

I have reviewed the attached product literature and certify the following:

- (1) That the above described “Or Equal” product fulfills the specification requirements as detailed in the Contract Documents.
- (2) That the installation of the above described “Or Equal” product in no way impacts the spatial requirements of the project.
- (3) That I, if selected as the Contractor, shall modify any building system(s) (HVAC, structural, electrical, etc.) impacted by the use of the above described “Or Equal” product at no additional cost to the City and County of Denver and shall make no claim for delay with respect to any such modification.
- (4) That the above described “Or Equal” product meets all physical and performance attributes of the specified material or equipment except (if no difference, so state):

\_\_\_\_\_

\_\_\_\_\_

\_\_\_\_\_

**REQUESTING PARTY:** \_\_\_\_\_

Date: \_\_\_\_\_ By: \_\_\_\_\_

Title: \_\_\_\_\_

**For City use:**

|   |                                      |             |
|---|--------------------------------------|-------------|
| <input type="checkbox"/> Approved       | <input type="checkbox"/> Disapproved | Date: _____ |
| Reason for disapproval [if applicable]: |                                      |             |
| <b>DESIGNER OF RECORD:</b>              |                                      |             |
| [Signature]                             |                                      |             |
| <b>PROJECT MANAGER:</b>                 |                                      | Date:       |
| [Signature]                             |                                      |             |
| <b>SVP-AIM:</b>                         |                                      | Date:       |
| [Signature]                             |                                      |             |
| Bidder(s) Notified By                   | Addendum No.                         | Date:       |

THIS IS PAGE 2 OF 2 PAGES

**EEO QUESTIONNAIRE**  
**Contract No.: 201737313**

1. Name of Business: \_\_\_\_\_
2. Address: \_\_\_\_\_
3. City, State, Zip Code: \_\_\_\_\_
4. Telephone Number: (\_\_\_\_\_) \_\_\_\_\_
5. Name and title of your firm's EEO Contact: \_\_\_\_\_
6. Are you an affiliate or a subsidiary of another business organization (branches, etc.)?  
 Yes  No
7. Type of business you are engaged in: \_\_\_\_\_
8. Does the organization have a procedure for resolving discrimination complaints?  
 Yes  No
9. Has your firm been charged with discrimination within the past eighteen (18) months?  
 Yes  No
10. Is your firm required to submit an EEO-1 annually to the EEOC?  
 Yes  No
11. Are you now working or have you worked on a City and County of Denver contract during the past twelve (12) months?  Yes  No  
 If yes, complete the following information:

| <u>Type of Contract</u> | <u>Contract Number</u> | <u>Total Cost of Each Contract</u> |
|-------------------------|------------------------|------------------------------------|
| _____                   | _____                  | _____                              |
| _____                   | _____                  | _____                              |
| _____                   | _____                  | _____                              |
| _____                   | _____                  | _____                              |

(You may use additional sheets if necessary)

**PROJECTION OF ANTICIPATED WORKFORCE**  
**Contract No. 201737313**

12. List the number of anticipated new employees needed by the contractor to perform this contract by trade/craft positions.

**ANTICIPATED NUMBER OF NEW EMPLOYEES FOR THIS CONTRACT**

| Trade<br>Craft | Estimated<br>Total<br>Manpower | Estimated<br>Total<br>Hours | Number of<br>Employees<br>Minority/Female | Total Estimated<br>Employees<br>Minority/Female |
|----------------|--------------------------------|-----------------------------|---|---|
| _____          | _____                          | _____                       | _____                                     | _____   |
| _____          | _____                          | _____                       | _____                                     | _____   |
| _____          | _____                          | _____                       | _____                                     | _____   |
| _____          | _____                          | _____                       | _____                                     | _____   |
| _____          | _____                          | _____                       | _____                                     | _____   |

13. What is the anticipated number of employees from the apparent low bidder's current work force to be utilized to perform this contract? \_\_\_\_\_

14. Estimate manpower utilization for the project below:

**ESTIMATE OF MANPOWER UTILIZATION**

| Trade<br>Craft | Estimated<br>Total<br>Manpower | Estimated<br>Total<br>Hours | Number of<br>Employees<br>Minority/Female | Total Estimated<br>Employees<br>Minority/Female |
|----------------|--------------------------------|-----------------------------|---|---|
| _____          | _____                          | _____                       | _____                                     | _____   |
| _____          | _____                          | _____                       | _____                                     | _____   |
| _____          | _____                          | _____                       | _____                                     | _____   |
| _____          | _____                          | _____                       | _____                                     | _____   |
| _____          | _____                          | _____                       | _____                                     | _____   |

15. Will the estimated total manpower (anticipated new hires and current staff to be utilized on this contract) meet the City's minority employment and female employment goals?

Yes  No

# **PREVAILING WAGES**

**The Prevailing Wage Schedule(s) which apply to this contract are contained in the pages immediately following this page. These pages are not included in the page numbering of this contract document.**





**DENVER**  
THE MILE HIGH CITY

**Office of Human Resources**  
Denver's Human Resource Agency

201 W. Colfax, Department 412

Denver, CO 80202

p: 720.913.5751

f: 720.913.5720

[www.denvergov.org/humanresources](http://www.denvergov.org/humanresources)

TO: All Users of the City of Denver Prevailing Wage Schedules  
FROM: Susan Keller, Human Resources Technician  
DATE: Thursday, October 5, 2017  
SUBJECT: Latest Change to Prevailing Wage Schedules

Please be advised, prevailing wage rates for some building, heavy, highway, and residential construction trades have not been updated by the United States Department of Labor (DOL) since March 1, 2002. The Career Service Board, in their meeting held on April 21, 2011, approved the use of the attached supplemental wage rates until prevailing wage rates for these classifications of work are again published by the United States Department of Labor in accordance with the Davis-Bacon Act.

The effective date for this publication will be **Friday, September 22, 2017** and applies to the City and County of Denver for **HEAVY CONSTRUCTION PROJECTS** in accordance with the Denver Revised Municipal Code, Section 20-76(c).

General Wage Decision No. CO170012  
Superseded General Decision No. CO20160012  
Modification No. 9  
Publication Date: 9/22/17  
(8 pages)

Unless otherwise specified in this document, apprentices shall be permitted only if they are employed pursuant to, and individually registered in, a bona fide apprenticeship program registered with the U.S. Department of Labor (DOL). The employer and the individual apprentice must be registered in a program, which has received prior approval, by the DOL. Any employer, who employs an apprentice and is found to be in violation of this provision, shall be required to pay said apprentice the full journeyman scale.

Attachments as listed above.

General Decision Number: CO170012 09/22/2017 CO12

Superseded General Decision Number: CO20160012

State: Colorado

Construction Type: Heavy

Counties: Adams, Arapahoe, Boulder, Broomfield, Denver, Douglas, El Paso, Jefferson, Larimer, Mesa, Pueblo and Weld Counties in Colorado.

HEAVY CONSTRUCTION PROJECTS

Note: Under Executive Order (EO) 13658, an hourly minimum wage of \$10.20 for calendar year 2017 applies to all contracts subject to the Davis-Bacon Act for which the contract is awarded (and any solicitation was issued) on or after January 1, 2015. If this contract is covered by the EO, the contractor must pay all workers in any classification listed on this wage determination at least \$10.20 (or the applicable wage rate listed on this wage determination, if it is higher) for all hours spent performing on the contract in calendar year 2017. The EO minimum wage rate will be adjusted annually. Additional information on contractor requirements and worker protections under the EO is available at [www.dol.gov/whd/govcontracts](http://www.dol.gov/whd/govcontracts).

| Modification Number | Publication Date |
|---------------------|------------------|
| 0                   | 01/06/2017       |
| 1                   | 01/20/2017       |
| 2                   | 02/03/2017       |
| 3                   | 04/07/2017       |
| 4                   | 05/19/2017       |
| 5                   | 05/26/2017       |
| 6                   | 06/02/2017       |
| 7                   | 06/09/2017       |
| 8                   | 07/21/2017       |
| 9                   | 09/22/2017       |

ASBE0028-001 07/01/2016

|   | Rates    | Fringes |
|---|----------|---------|
| Asbestos Workers/Insulator<br>(Includes application of all insulating materials, protective coverings, coatings and finishings to all types of mechanical systems)..... | \$ 29.73 | 13.93   |

BRCO0007-004 01/01/2017

ADAMS, ARAPAHOE, BOULDER, BROOMFIELD, DENVER, DOUGLAS AND JEFFERSON COUNTIES

|                 | Rates    | Fringes |
|-----------------|----------|---------|
| BRICKLAYER..... | \$ 26.62 | 7.99    |

BRCO0007-006 05/01/2017

EL PASO AND PUEBLO COUNTIES

|                 | Rates    | Fringes |
|-----------------|----------|---------|
| BRICKLAYER..... | \$ 25.32 | 9.90    |

-----  
ELEC0012-004 09/01/2016

PUEBLO COUNTY

|                           | Rates    | Fringes  |
|---------------------------|----------|----------|
| ELECTRICIAN               |          |          |
| Electrical contract over  |          |          |
| \$1,000,000.....          | \$ 28.00 | 11.00+3% |
| Electrical contract under |          |          |
| \$1,000,000.....          | \$ 24.85 | 11.00+3% |

-----  
ELEC0068-001 06/01/2017

ADAMS, ARAPAHOE, BOULDER, BROOMFIELD, DENVER, DOUGLAS,  
JEFFERSON, LARIMER, AND WELD COUNTIES

|                  | Rates    | Fringes |
|------------------|----------|---------|
| ELECTRICIAN..... | \$ 34.70 | 14.97   |

-----  
\* ELEC0111-001 09/01/2017

|                              | Rates    | Fringes         |
|------------------------------|----------|-----------------|
| Line Construction:           |          |                 |
| Groundman.....               | \$ 25.68 | 25.25%+\$5.75   |
| Line Equipment Operator..... | \$ 31.35 | 25.25% + \$5.75 |
| Lineman and Welder.....      | \$ 44.92 | 25.25%+\$5.75   |

-----  
ELEC0113-002 06/01/2017

EL PASO COUNTY

|                  | Rates    | Fringes |
|------------------|----------|---------|
| ELECTRICIAN..... | \$ 31.00 | 15.38   |

-----  
ELEC0969-002 06/01/2015

MESA COUNTY

|                  | Rates    | Fringes |
|------------------|----------|---------|
| ELECTRICIAN..... | \$ 24.00 | 7.92    |

-----  
ENGI0009-001 05/01/2017

|                            | Rates    | Fringes |
|----------------------------|----------|---------|
| Power equipment operators: |          |         |
| Blade: Finish.....         | \$ 27.92 | 10.10   |
| Blade: Rough.....          | \$ 27.60 | 10.10   |
| Bulldozer.....             | \$ 27.60 | 10.10   |

|   |          |       |
|---|----------|-------|
| Cranes: 50 tons and under..   | \$ 27.75 | 10.10 |
| Cranes: 51 to 90 tons.....  | \$ 27.92 | 10.10 |
| Cranes: 91 to 140 tons.....   | \$ 28.55 | 10.10 |
| Cranes: 141 tons and over...  | \$ 29.82 | 10.10 |
| Forklift.....   | \$ 27.22 | 10.10 |
| Mechanic.....   | \$ 28.08 | 10.10 |
| Oiler.....  | \$ 26.84 | 10.10 |
| Scraper: Single bowl<br>under 40 cubic yards.....   | \$ 27.75 | 10.10 |
| Scraper: Single bowl,<br>including pups 40 cubic<br>yards and over and tandem<br>bowls..... | \$ 27.92 | 10.10 |
| Trackhoe.....   | \$ 27.75 | 10.10 |

-----  
IRON0024-003 05/01/2017

|                   | Rates    | Fringes |
|-------------------|----------|---------|
| Ironworkers:..... | \$ 26.30 | 21.45   |
| Structural        |          |         |

-----  
LABO0086-001 05/01/2009

|                             | Rates    | Fringes |
|-----------------------------|----------|---------|
| Laborers:<br>Pipelayer..... | \$ 18.68 | 6.78    |

-----  
PLUM0003-005 06/01/2017

ADAMS, ARAPAHOE, BOULDER, BROOMFIELD, DENVER, DOUGLAS,  
JEFFERSON, LARIMER AND WELD COUNTIES

|              | Rates    | Fringes |
|--------------|----------|---------|
| PLUMBER..... | \$ 39.08 | 16.44   |

-----  
PLUM0058-002 07/01/2017

EL PASO COUNTY

|                               | Rates    | Fringes |
|-------------------------------|----------|---------|
| Plumbers and Pipefitters..... | \$ 36.50 | 14.10   |

-----  
PLUM0058-008 07/01/2017

PUEBLO COUNTY

|                               | Rates    | Fringes |
|-------------------------------|----------|---------|
| Plumbers and Pipefitters..... | \$ 36.50 | 14.10   |

-----  
PLUM0145-002 07/01/2016

MESA COUNTY

|                               | Rates    | Fringes |
|-------------------------------|----------|---------|
| Plumbers and Pipefitters..... | \$ 35.17 | 11.70   |

-----

PLUM0208-004 06/01/2016

ADAMS, ARAPAHOE, BOULDER, BROOMFIELD, DENVER, DOUGLAS,  
JEFFERSON, LARIMER AND WELD COUNTIES

|                 | Rates    | Fringes |
|-----------------|----------|---------|
| PIPEFITTER..... | \$ 37.10 | 16.62   |

-----  
SHEE0009-002 07/01/2017

|                         | Rates    | Fringes |
|-------------------------|----------|---------|
| Sheet metal worker..... | \$ 33.26 | 16.61   |

-----  
TEAM0455-002 07/01/2016

|                            | Rates    | Fringes |
|----------------------------|----------|---------|
| Truck drivers:             |          |         |
| Pickup.....                | \$ 20.16 | 4.02    |
| Tandem/Semi and Water..... | \$ 20.79 | 4.02    |

-----  
SUCO2001-006 12/20/2001

|                                   | Rates    | Fringes |
|-----------------------------------|----------|---------|
| BOILERMAKER.....                  | \$ 17.60 |         |
| Carpenters:                       |          |         |
| Form Building and Setting...      | \$ 16.97 | 2.74    |
| All Other Work.....               | \$ 15.14 | 3.37    |
| Cement Mason/Concrete Finisher... | \$ 17.31 | 2.85    |
| IRONWORKER, REINFORCING.....      | \$ 18.83 | 3.90    |
| Laborers:                         |          |         |
| Common.....                       | \$ 11.22 | 2.92    |
| Flagger.....                      | \$ 8.91  | 3.80    |
| Landscape.....                    | \$ 12.56 | 3.21    |
| Painters:                         |          |         |
| Brush, Roller & Spray.....        | \$ 15.81 | 3.26    |
| Power equipment operators:        |          |         |
| Backhoe.....                      | \$ 16.36 | 2.48    |
| Front End Loader.....             | \$ 17.24 | 3.23    |
| Skid Loader.....                  | \$ 15.37 | 4.41    |

-----  
WELDERS - Receive rate prescribed for craft performing  
operation to which welding is incidental.

**Office of Human Resources**  
**Supplemental rates**  
**(Specific to the Denver Projects)**  
**(Supp #74, Date: 02-03-2012)**

| <b><u>Classification</u></b>   |                                  | <b><u>Base</u></b> | <b><u>Fringe</u></b> |
|--|----------------------------------|--------------------|----------------------|
| Ironworkers (Ornamental)   |                                  | \$24.80            | \$10.03              |
| Laborers: Janitors/Yardmen   |                                  | \$17.68            | \$8.22               |
| Laborers:  |                                  |                    |                      |
|  | GROUP 1                          | \$18.18            | \$8.27               |
|  | GROUP 2                          | \$21.59            | \$8.61               |
| Laborers: (Tunnel)   |                                  |                    |                      |
|  | GROUP 1                          | \$18.53            | \$8.30               |
|  | GROUP 2                          | \$18.63            | \$8.31               |
|  | GROUP 3                          | \$19.73            | \$8.42               |
|  | GROUP 4                          | \$21.59            | \$8.61               |
|  | GROUP 5                          | \$19.68            | \$8.42               |
| Laborers (Removal of Asbestos)   |                                  | \$21.03            | \$8.55               |
| Line Construction:   |                                  |                    |                      |
|  | Lineman, Gas Fitter/Welder       | \$36.88            | \$9.55               |
|  | Line Eq Operator/Line Truck Crew | \$25.74            | \$8.09               |
| Millwrights  |                                  | \$28.00            | \$10.00              |
| Power Equipment Operators<br>(Tunnels Above and Below<br>Ground, shafts and raises): |                                  |                    |                      |
|  | GROUP 1                          | \$25.12            | \$10.81              |
|  | GROUP 2                          | \$25.47            | \$10.85              |
|  | GROUP 3                          | \$25.57            | \$10.86              |
|  | GROUP 4                          | \$25.82            | \$10.88              |
|  | GROUP 5                          | \$25.97            | \$10.90              |
|  | GROUP 6                          | \$26.12            | \$10.91              |
|  | GROUP 7                          | \$26.37            | \$10.94              |
| Power Equipment Operators:   |                                  |                    |                      |
|  | GROUP 1                          | \$22.97            | \$10.60              |
|  | GROUP 2                          | \$23.32            | \$10.63              |
|  | GROUP 3                          | \$23.67            | \$10.67              |
|  | GROUP 4                          | \$23.82            | \$10.68              |
|  | GROUP 5                          | \$23.97            | \$10.70              |
|  | GROUP 6                          | \$24.12            | \$10.71              |
|  | GROUP 7                          | \$24.88            | \$10.79              |
| Truck Drivers:   |                                  |                    |                      |
|  | GROUP 1                          | \$18.42            | \$10.00              |
|  | GROUP 2                          | \$19.14            | \$10.07              |
|  | GROUP 3                          | \$19.48            | \$10.11              |
|  | GROUP 4                          | \$20.01            | \$10.16              |
|  | GROUP 5                          | \$20.66            | \$10.23              |
|  | GROUP 6                          | \$21.46            | \$10.31              |

POWER EQUIPMENT OPERATOR CLASSIFICATIONS  
(TUNNELS ABOVE AND BELOW GROUND, SHAFTS, AND RAISES):

GROUP 1 - Brakeman

GROUP 2 - Motorman

GROUP 3 - Compressor

GROUP 4 - Air Tractors; Grout Machine; Gunnite Machine; Jumbo Form

GROUP 5 - Concrete Placement Pumps; Mucking Machines and Front End Loaders, Underground, Slusher; Mine Hoist Operator; Mechanic

GROUP 6 - Mechanic Welder

GROUP 7 - Mole

*NOTE: Any equipment listed below being used in tunnel work, below or above ground shall be paid not less than \$2.00 per hour above the listed wage rates.*

POWER EQUIPMENT OPERATOR CLASSIFICATIONS:

GROUP 1 - Air compressor, brakeman, drill operator - smaller than Watson 2500 and similar, operators of 5 or more light plants, welding machines, generators, single unit conveyor, pumps, vacuum well point system, tractor, under 70 hp with or without attachments compressors, 360 C.F.M. or less.

GROUP 2 - Conveyor, handling **building** materials, ditch witch and similar trenching machine, haulage motor man, pugmill, portable screening plant with or without a spray bar, screening plants, with classifier.

GROUP 3 - Asphalt screed, asphalt plant, backfiller, bituminous spreader or laydown machine; cableway signalman, caisson drill, William MF, similar or larger; C.M.I. and similar, concrete batching plants, concrete finish machine, concrete gang saw on concrete paving, concrete mixer, less than 1 yd., concrete placement pumps, under 8 inches, distributors, bituminous surfaces dozer, drill, diamond or core, drill rigs, rotary, churn, or cable tool, elevating graders, elevator operator, equipment, lubricating and service engineer, grout machine, gunnite machine, hoist, 1 drum, horizontal directional drill operator, sandblasting machine, single unit portable crusher, with or without washer, tie tamper, wheel mounted, tractor, 70 hp and over with or without attachments, trenching machine operator, winch on truck.

GROUP 4 - Cable operated power shovels, draglines, articulated truck operator, clamshells, and backhoes, 5 cubic yards and under, concrete mixer over 1 cubic yard, concrete paver 34E or similar, concrete placement pumps, 8 inches and over, grade checker, hoist, 2 drums, hydraulic backhoe, 3/4 yds and over, loader, over 6 cubic yards, mechanic, mixer mobile, multiple unit portable crusher, with or without washer; pile driver, tractor with side boom, roto- mill and similar, welder.

GROUP 5 - Cable operated power shovels, draglines, clamshells and backhoes over 5 cubic yards, caisson drill Watson 2500 similar or larger, hoist 3 drum or more, mechanic – welder (heavy-duty).

GROUP 6 - Cableway, derrick, quad nine push unit, wheel excavator, belt or elevating loader

GROUP 7 - tower cranes all types

LABORER CLASSIFICATIONS:

GROUP 1 –Erosion Control, Dowel Bars; Fence Erectors; Gabion Basket and Reno mattresses; Signaling, Metal Mesh; Stake Caser; Traffic Control Devices; Tie Bars and Chairs in Concrete; Paving; Waterproofing Concrete; Air, Gas, Hydraulic Tools and Electrical Tool Operators; Barco Hammers; Cutting Torches; drill; diamond and core drills; Core, diamond, air track including but not limited to; Joy, Mustang, PR-143, 220 Gardner-**Denver**, Hydrosonic, and water blaster operator; Chuck Tender; Electric hammers; Jackhammers; Hydraulic Jacks; Tampers; Air Tampers; Automatic Concrete Power Curbing Machines; Concrete Processing Material; Concrete Tender; Operators of concrete saws on pavement (other than gangsaws); Power operated Concrete Buggies; Hot Asphalt Labor; Asphalt Curb Machines; Paving Breakers; Transverse Concrete Conveyor Operator; Cofferdams; Boxtenders; Caisson 8' to 12'; Caisson Over 12'; Jackhammer Operators in Caissons over 12'; Labor applicable to Pipe coating or Wrapping; Pipe Wrappers, Plant and Yard; Relining

Pipe; Hydroliner (a plastic may be used to waterproof); Pipelayer on Underground Bores; Sewer, Water, Gas, Oil Conduit; Enamalers on Pipe, inside and out, Mechanical Grouters; Monitors; Jeep Holiday Detector Men; Pump Operators; Rakers; Vibrators; Hydro- broom, Mixer Man; Gunitite Nozzlemen; Shotcrete Operator; and chain saws, gas and electric; Sand Blaster; Licensed Powdermen; Powdermen and Blaster; Siphons; Signalmen; Dumpman/spotter; Grade Checker.

GROUP 2 - Plug and galleys in dams; Scalars; any work on or off Bridges 40' above the ground performed by Laborers working from a Bos'n Chair, Swing Stage, Life Belt, or Block and Tackle as a safety requirement.

### TUNNEL LABORER CLASSIFICATIONS:

GROUP 1 - Outside Laborer - Above ground

GROUP 2 - Minimum Tunnel Laborer, Dry Houseman

GROUP 3 - Cable or Hose Tenders, Chuck Tenders, Concrete Laborers, Dumpmen, Whirley Pump Operators

GROUP 4 - Tenders on Shotcrete, Guniting and Sand Blasting; Tenders, core and Diamond Drills; Pot Tenders

GROUP 5 - Collapsible Form Movers and Setters; Miners; Machine Men and Bit Grinders; Nippers; Powdermen and Blasters; Reinforcing Steel Setters; Timbermen (steel or wood tunnel support, including the placement of sheeting when required); and all Cutting and Welding that is incidental to the Miner's work; Tunnel Liner Plate Setters; Vibrator Men, Internal and External; Unloading, stopping and starting of Moran Agitator Cars; Diamond and Core Drill Operators; Shotcrete operator; Gunitite Nozzlemen; Sand Blaster; Pump Concrete Placement Men.

Laborers (Removal of Asbestos) Removal or encapsulation of Asbestos Material (including removal of asbestos from mechanical systems that are going to be scraped) and work involving the removal, handling, or dealing with toxic or hazardous waste.

### TRUCK DRIVER CLASSIFICATIONS:

GROUP 1 - Sweeper Truck, Flat Rack Single Axle and Manhaul, Shuttle Truck or Bus.

GROUP 2 - Dump Truck Driver to and including 6 cubic yards, Dump Truck Driver over 6 cubic yards to and including 14 cubic yards, Straddle Truck Driver, Liquid and Bulk Tankers Single Axle, Euclid Electric or Similar, Multipurpose Truck Specialty and Hoisting.

GROUP 3 - Truck Driver Snow Plow.

GROUP 4 - Cement Mixer Agitator Truck over 10 cubic yards to and including 15 cubic yards.

WELDERS: Receive rate prescribed for craft performing operation to which welding is incidental.





The undersigned acknowledges receipt, understanding and full consideration of the following addenda to the Contract Documents:

Addenda Nos.:

1 (4/1/17)

---

The undersigned agrees that this bid is a firm offer to the City to perform and complete the Contract described above which cannot be withdrawn for one hundred twenty (120) calendar days after the bids are opened or until after a contract for the work described in these bid documents is fully executed by the City, whichever date is earlier.

The undersigned Bidder hereby agrees to appear at Denver International Airport, Business Management Services Office, Room 8810, Airport Office Building, at any time within seven (7) business days from the date of a written notice from the CEO to do so, mailed, emailed, or faxed to the business address of Bidder and at that time the Bidder shall: (1) deliver an executed Contract which conforms with this bid; (2) furnish the required performance and payment bonds in the sum of the Total Contract Bid Amount shown above, executed by a surety company acceptable to the CEO; and (3) furnish the required insurance documents.

Enclosed herewith is a bid guarantee, as defined in the Instructions to Bidders, in the amount of which bid guarantee the undersigned Bidder agrees is to be paid to and become the property of the City as liquidated damages should the bid be considered to be the best by the City and the undersigned Bidder notified that it is the apparent low bidder and it fails to enter into contract in the form prescribed and to furnish the required performance and payment bonds and evidences of insurance within seven (7) business days as stipulated above.

Attached and incorporated herein are the proposed Schedule of Prices and Quantities and Bid Data Forms. All of the forms must be completed. Bidder acknowledges that the City may incorporate, at its option, any or all of the data submitted by the Bidder into a contract arising out of this Bid.

The undersigned Bidder acknowledges the right of the City to waive informalities in the bids, to reject any or all bids submitted, and to re-advertise for bids.

The undersigned certifies that it has examined and is fully familiar with all of the provisions of the Contract Documents and is satisfied that they are accurate; that it has carefully checked all words and figures and all statements made in these Bid forms; and that it has satisfied itself with respect to the actual site conditions and the nature and location of the Work, the general and local conditions which may be encountered in the performance of the Work, and other matters which in any way affect the Work or the cost thereof.

[CERTIFICATION AND SIGNATURE ON FOLLOWING PAGES]

This bid is submitted upon the declaration that neither, I (we), nor, to the best of my (our) knowledge, none of the members of my (our) firm or company have either directly or indirectly entered into any agreement, participated in any collusion or otherwise taken any action in restraint of free competitive bidding in connection with this bid.

Dated this 3RD day of NOVEMBER, 2017.

**BUSINESS ADDRESS OF BIDDER:** 5670 FRANKLIN ST

City, State, Zip Code: DENVER, CO 80216

Telephone Number of Bidder: (303) 297-0346

Fax Number of Bidder: (303) 294-9601

Social Security or Employer Id. No. of Bidder: 84-1129267

Email Address: MWALTERS@HAMONINFRASTRUCTURE.COM

**SIGNATURE OF BIDDER:**

PRINT NAME OF BIDDER:

HAMON INFRASTRUCTURE, INC

Attest:

(Corporate Seal)



Secretary  
MICHAEL D. WALTERS

By:

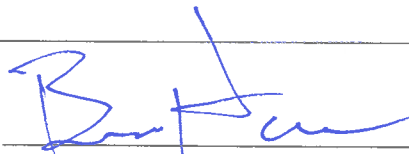

President

BRUCE W. HAMON

# **SCHEDULE OF PRICES AND QUANTITIES**

**The Schedule of Prices and Quantities which apply to this contract are contained in the pages immediately following this page. These pages are not included in the page numbering of this contract document.**



Pond 001 Expansion - Schedule I

| Item No.   | Description   | Units | Est. Qty | Unit Price               | Total                     |
|------------|---|-------|----------|--------------------------|---------------------------|
| 013223a    | Survey  | LS    | 1        | \$ 79,329. <sup>35</sup> | \$ 79,329. <sup>35</sup>  |
|            | at the unit price of: <u>SEVENTY-NINE THOUSAND THREE HUNDRED TWENTY-NINE THIRTY-FIVE</u> dollars and cents. |       |          |                          |                           |
| 015050a    | Mobilization  | LS    | 1        | \$ 143,000 <sup>-</sup>  | \$ 143,000 <sup>-</sup>   |
|            | at the unit price of: <u>ONE HUNDRED FORTY THREE THOUSAND</u> dollars and cents.                            |       |          |                          |                           |
| 015525a    | Traffic Control   | LS    | 1        | \$ 40,000 <sup>-</sup>   | \$ 40,000 <sup>-</sup>    |
|            | at the unit price of: <u>FORTY THOUSAND</u> dollars and cents.  |       |          |                          |                           |
| 015525b    | Flagger   | HR    | 2,000    | \$ 25 <sup>-</sup>       | \$ 50,000 <sup>-</sup>    |
|            | at the unit price of: <u>TWENTY-FIVE</u> dollars and cents.   |       |          |                          |                           |
| 015525c    | Gate Guard  | HR    | 2,000    | \$ 35 <sup>-</sup>       | \$ 70,000 <sup>-</sup>    |
|            | at the unit price of: <u>THIRTY-NINE</u> dollars and cents.   |       |          |                          |                           |
| 015525d    | Gate Guard Shack  | LS    | 1        | \$ 40,000 <sup>-</sup>   | \$ 40,000 <sup>-</sup>    |
|            | at the unit price of: <u>FORTY THOUSAND</u> dollars and cents.  |       |          |                          |                           |
| 015719a    | Sediment Control Logs   | LF    | 3,270    | \$ 6 <sup>-</sup>        | \$ 19,620 <sup>-</sup>    |
|            | at the unit price of: <u>SIX</u> dollars and cents.   |       |          |                          |                           |
| 015719b    | Cuivert Protection  | EA    | 3        | \$ 1,400 <sup>-</sup>    | \$ 4,200 <sup>-</sup>     |
|            | at the unit price of: <u>ONE THOUSAND FOUR HUNDRED</u> dollars and cents.                                   |       |          |                          |                           |
| 015719c    | Vehicle Tracking Control  | EA    | 1        | \$ 3,400 <sup>-</sup>    | \$ 3,400 <sup>-</sup>     |
|            | at the unit price of: <u>THREE THOUSAND FOUR HUNDRED</u> dollars and cents.                                 |       |          |                          |                           |
| 015719d    | Concrete Washout  | EA    | 1        | \$ 1,900 <sup>-</sup>    | \$ 1,900 <sup>-</sup>     |
|            | at the unit price of: <u>ONE THOUSAND NINE HUNDRED</u> dollars and cents.                                   |       |          |                          |                           |
| 260500a    | Electrical, Instrumentation, and Controls   | LS    | 1        | \$ 264,288 <sup>-</sup>  | \$ 264,288 <sup>-</sup>   |
|            | at the unit price of: <u>TWO HUNDRED SIXTY-FOUR THOUSAND TWENTY EIGHT</u> dollars and cents.                |       |          |                          |                           |
| 310519.14a | NonWoven Geotextile Fabric  | SY    | 4,365    | \$ 4.01                  | \$ 17,503.65 <sup>-</sup> |
|            | at the unit price of: <u>FOUR</u> dollars and cents.  |       |          |                          |                           |
| 310519.15a | Geocomposite Drainage Net with 10 OZ Fabric   | SY    | 14,740   | \$ 7.05 <sup>-</sup>     | \$ 103,917 <sup>-</sup>   |
|            | at the unit price of: <u>SEVEN FIVE</u> dollars and cents.  |       |          |                          |                           |
| 310519.17a | 60 MIL RPP Geomembrane Liner  | SY    | 14,740   | \$ 13.50 <sup>-</sup>    | \$ 198,990 <sup>-</sup>   |
|            | at the unit price of: <u>THIRTEEN FIFTY</u> dollars and cents.  |       |          |                          |                           |

Pond 001 Expansion - Schedule I

| Item No.   | Description  | Units | Est. Qty | Unit Price              | Total                   |
|------------|--|-------|----------|-------------------------|-------------------------|
| 352016.02a | 8'x8' Slide Gate with Hydraulic Operator   | LS    | 1        | \$ 230,000 <sup>-</sup> | \$ 230,000 <sup>-</sup> |
|            | at the unit price of: <u>TWO HUNDRED THIRTY</u><br><u>SEVEN</u> dollars and <u>NO</u> cents.       |       |          |                         |                         |
| P-150a     | Remove Riprap  | SY    | 106      | \$ 16 <sup>-</sup>      | \$ 1,696 <sup>-</sup>   |
|            | at the unit price of: <u>SIXTEEN</u><br><u>NO</u> dollars and cents.                               |       |          |                         |                         |
| P-150b     | Remove 12" DIW (PVC)   | LF    | 371      | \$ 40 <sup>-</sup>      | \$ 14,840 <sup>-</sup>  |
|            | at the unit price of: <u>FORTY</u><br><u>NO</u> dollars and cents.                                 |       |          |                         |                         |
| P-150c     | Remove 12" SDG (RCP)   | LF    | 44       | \$ 30 <sup>-</sup>      | \$ 1,320 <sup>-</sup>   |
|            | at the unit price of: <u>THIRTY</u><br><u>NO</u> dollars and cents.                                |       |          |                         |                         |
| P-150d     | Remove DIW Manhole   | EA    | 2        | \$ 1,215 <sup>-</sup>   | \$ 2,430 <sup>-</sup>   |
|            | at the unit price of: <u>ONE THOUSAND TWO HUNDRED</u><br><u>FIFTY</u> dollars and <u>NO</u> cents. |       |          |                         |                         |
| P-150e     | Place 6" Recycled Crushed Concrete   | SY    | 1,100    | \$ 11.50 <sup>-</sup>   | \$ 12,650 <sup>-</sup>  |
|            | at the unit price of: <u>ELEVEN</u><br><u>FIFTY</u> dollars and cents.                             |       |          |                         |                         |
| P-152a     | Unclassified Excavation  | CY    | 64,611   | \$ 14 <sup>-</sup>      | \$ 904,554 <sup>-</sup> |
|            | at the unit price of: <u>FOURTEEN</u><br><u>NO</u> dollars and cents.                              |       |          |                         |                         |
| P-610a     | Concrete Pavement (6" Fiber-Reinforced)  | SY    | 4,365    | \$ 69 <sup>-</sup>      | \$ 301,185 <sup>-</sup> |
|            | at the unit price of: <u>SIXTY NINE</u><br><u>AND</u> dollars and cents.                           |       |          |                         |                         |
| D-701a     | Install 8" DIWF (C900 PVC)   | LF    | 148      | \$ 110 <sup>-</sup>     | \$ 16,280 <sup>-</sup>  |
|            | at the unit price of: <u>ONE HUNDRED TEN</u><br><u>NO</u> dollars and cents.                       |       |          |                         |                         |
| D-701b     | Install 12" DIW (C900 PVC)   | LF    | 528      | \$ 160 <sup>-</sup>     | \$ 84,480 <sup>-</sup>  |
|            | at the unit price of: <u>ONE HUNDRED SIXTY</u><br><u>NO</u> dollars and cents.                     |       |          |                         |                         |
| D-701c     | Install 12" SDG (Class III RCP)  | LF    | 44       | \$ 135 <sup>-</sup>     | \$ 5,940 <sup>-</sup>   |
|            | at the unit price of: <u>ONE HUNDRED THIRTY-FIVE</u><br><u>NO</u> dollars and cents.               |       |          |                         |                         |
| D-701d     | Install 12" FES (RCP)  | EA    | 2        | \$ 1,200 <sup>-</sup>   | \$ 2,400 <sup>-</sup>   |
|            | at the unit price of: <u>ONE THOUSAND TWO HUNDRED</u><br><u>AND</u> dollars and cents.             |       |          |                         |                         |
| D-701e     | Install 16" DIW (C905 PVC)   | LF    | 165      | \$ 290 <sup>-</sup>     | \$ 47,850 <sup>-</sup>  |
|            | at the unit price of: <u>TWO HUNDRED NINETY</u><br><u>AND</u> dollars and cents.                   |       |          |                         |                         |
| D-701f     | Install 16" Intake Pipe & Sceen (Stainless Steel)  | LS    | 1        | \$ 100,000 <sup>-</sup> | \$ 100,000 <sup>-</sup> |
|            | at the unit price of: <u>ONE HUNDRED THOUSAND</u><br><u>AND</u> dollars and cents.                 |       |          |                         |                         |

Pond 001 Expansion - Schedule I

| Item No. | Description   | Units   | Est. Qty | Unit Price    | Total         |
|----------|---|---|----------|---------------|---------------|
| D-701g   | Install 108" DIW (Class III RCP)                        | at the unit price of:<br>TEN THOUSAND FIVE HUNDRED dollars and NO cents.              | LF       | 590 \$ 2,500- | \$ 1,475,000- |
| D-701h   | Install 108" DIW 45° Bend                               | at the unit price of:<br>EVEN THOUSAND NO dollars and NO cents.                       | EA       | 2 \$ 11,000-  | \$ 22,000-    |
| D-705a   | Install 6" Underdrain (Perforated PVC)                  | at the unit price of:<br>EIGHTY NO dollars and NO cents.                              | LF       | 173 \$ 80-    | \$ 13,840-    |
| D-705b   | Install 12" Underdrain (Non-Perforated PVC)             | at the unit price of:<br>EIGHTY-FIVE NO dollars and NO cents.                         | LF       | 132 \$ 85-    | \$ 11,220-    |
| D-710a   | Grouted Type M Riprap                                   | at the unit price of:<br>ONE HUNDRED TEN NO dollars and NO cents.                     | SY       | 110 \$ 110-   | \$ 12,100-    |
| D-751a   | Modify Existing Diversion Structure                     | at the unit price of:<br>THREE THOUSAND NINETY-FIVE THOUSAND NO dollars and NO cents. | LS       | 1 \$ 395,000- | \$ 395,000-   |
| D-751b   | Install DIW Manhole 6' Diameter With 16" Plug Valve     | at the unit price of:<br>SIXTY THOUSAND NO dollars and NO cents.                      | EA       | 2 \$ 60,000-  | \$ 120,000-   |
| D-751c   | Install DIW Manhole 6' Diameter With 2 - 8" Plug Valves | at the unit price of:<br>FORTY-FIVE THOUSAND DOLLARS NO CENTS                         | EA       | 2 \$ 45,000-  | \$ 90,000-    |
| D-751d   | Install DIW Manhole 5' Diameter                         | at the unit price of:<br>SIX THOUSAND TWO HUNDRED NO dollars and NO cents.            | EA       | 3 \$ 6,200-   | \$ 18,600-    |
| D-751e   | Install Head Wall & Wingwalls (108" Outfall)            | at the unit price of:<br>ONE HUNDRED THIRTY THOUSAND NO dollars and NO cents.         | LS       | 1 \$ 130,000- | \$ 130,000-   |
| T-901a   | Seeding (Seed Mix Design 2)                             | at the unit price of:<br>FIVE HUNDRED SIXTY-SIX NO dollars and NO cents.              | AC       | 7 \$ 516-     | \$ 3,612-     |
| T-908a   | Hydraulic Mulching                                      | at the unit price of:<br>ONE THOUSAND TWO HUNDRED SIXTY-FIVE NO dollars and NO cents. | AC       | 7 \$ 1265-    | \$ 8855-      |

Schedule I



**DENVER INTERNATIONAL AIRPORT**

**Pond 001 Expansion  
Contract No. 201737313**

**Bid Data Forms**

Bidder shall submit its Bid Data in accordance with the format shown on each of the following Bid Data Forms. Bidder shall prepare and use as many sheets as are necessary to provide the information required. Bidder shall ensure that each page of its Bid Data is completed and properly identified with the Bid Data form name, Bidder's name, and page number.

DENVER INTERNATIONAL AIRPORT

Pond 001 Expansion  
Contract No. 201737313

Bid Data Forms  
INFORMATION ABOUT CONTRACTOR

1. Name of Bidder/Contractor: HAMON INFRASTRUCTURE, INC
2. Type of business entity: CORPORATION  
NOTE: If bidder is a **partnership** or **joint venture**, give full names of all partners or joint venturers. Bid must be signed by all joint venturers. If bidder is a **limited liability company**, bid must be signed by authorized manager (may be signed by member-manager if LLC is organized to allow management by members).
3. Prequalified by City and County of Denver as Construction Contractor : Categories: I.B. EXCAVATION ; GRADING  
Monetary Limit: \$ 6,000,000
4. Address of Contractor: 5670 FRANKLIN ST  
DENVER, CO 80216  
  
Telephone: 303-297-0340 Fax: 303-296-9601  
Email Address: MANAGERS@HAMONINFRASTRUCTURE.COM
5. Established where and when: COLORADO - 1990
6. Contractor's Banks: COLORADO BUSINESS BANK
7. Principal Officers of Contractor (managers and members if LLC):  
Name: BRUCE W. HAMON Name: MICHAEL D. WALTERS  
Title: PRESIDENT Title: VP / SEC / TREAS  
  
Name: \_\_\_\_\_ Name: \_\_\_\_\_  
Title: \_\_\_\_\_ Title: \_\_\_\_\_

8. Bidder's/Contractor's City and County of Denver Contractor License if it has obtained one:

License No.:

APPLIED FOR

*APPLIED FOR*

Class:

APPLIED FOR

A contractor license is required prior to start of construction but not prior to bid submittal.

9. Bidder's/Contractor's state of incorporation (state of organization if an LLC or partnership):

COLORADO

10. Bidder's Surety:

GREAT AMERICAN INSURANCE COMPANY

11. Surety's State of Incorporation:

OHIO

12. Address of Contractor in other areas (if different from No. 4):

N/A

13. Name and address of person to receive payments:

MICHAEL D. WALTERS

5670 FRANKLIN ST.

SEASIDE, CO 80216

14. If the Bidder/Contractor is a joint venture, it shall attach a certified copy of the joint venture agreement. The joint venture agreement will not be included as a Contract Document. N/A

15. The Bidder/Contractor shall identify all applicable labor agreements (if any) to be used in the performance of the Work:

NONE

Bidder HAMON INFRASTRUCTURE, INC

**DENVER INTERNATIONAL AIRPORT**

**Pond 001 Expansion  
Contract No. 201737313**

**Bid Data Forms**

**LIST OF PROPOSED SUBCONTRACTORS WHICH  
ARE NOT DBE SUBCONTRACTORS**

Bidder shall list below the name, business address, work assignment and dollar value of each subcontractor that is not a DBE subcontractor which will perform work or labor or provide services to the Bidder relating to this contract in an amount greater than one and one-half percent of the Bidder's total bid. Only one subcontractor for each portion of the work shall be listed. Any proposed subcontractors to be utilized by the Bidder that are certified as a Small Business Enterprise shall also be listed on the "List of Proposed Subcontractors" attached to these Bid Forms.

If the bidder does not identify a subcontractor to perform portions of the work which could be subcontracted on this form or the List of Proposed DBE Subcontractors, the Bidder, if it is awarded the contract, agrees not to subcontract such portions that exceed one and one half percent of the total bid amount until the Contractor has advised the SVP-AIM in writing of the reasons why the subcontractor was not listed in the bid and complied with the requirements of General Condition 502.

If the bidder is awarded the contract and does not enter into a subcontract with a subcontractor listed below or on the List of Proposed DBE Subcontractors, the Contractor agrees not to subcontract any of the work assignment identified for that subcontractor until the Contractor has advised the SVP-AIM in writing of the reasons why a different subcontractor is being used and has obtained approval of the SVP-AIM of the substitution. This requirement does not affect the applicability of 502.

| Subcontractor   | Work Assignment | Subcontract Dollar Value |
|---|-----------------|--------------------------|
| NAME: <u>COLORADO LINING</u><br>ADDRESS: <u>1062 SINGING HILLS RD</u><br><u>PARKER CO 80138</u><br>PHONE: <u>303-841-2022</u> | <u>LINING</u>   | <u>311,000-</u>          |

| Subcontractor  | Work Assignment   | Subcontract Dollar Value |
|--|-------------------|--------------------------|
| NAME: <u>STURGEON ELECTRIC</u><br>ADDRESS: <u>12150 E. 112TH AVE</u><br><u>HENDERSON, CO 80640</u><br>PHONE: <u>303-286-8000</u> | <u>ELECTRICAL</u> | <u>264,000</u>           |
| NAME: _____<br>ADDRESS: _____<br>PHONE: _____  |                   |                          |
| NAME: _____<br>ADDRESS: _____<br>PHONE: _____  |                   |                          |
| NAME: _____<br>ADDRESS: _____<br>PHONE: _____  |                   |                          |
| NAME: _____<br>ADDRESS: _____<br>PHONE: _____  |                   |                          |
| NAME: _____<br>ADDRESS: _____<br>PHONE: _____  |                   |                          |
| NAME: _____<br>ADDRESS: _____<br>PHONE: _____  |                   |                          |
| NAME: _____<br>ADDRESS: _____<br>PHONE: _____  |                   |                          |

(This page can be duplicated if additional sheets are required.)

# DIVERSITY AND INCLUSIVENESS IN CITY SOLICITATIONS

In order for the agency or City to consider the bid or proposal, Contractors must complete the electronic version of the Diversity And Inclusiveness In City Solicitations Form then **print the completed form and include the hard copy as part of its bid documents. A proposal or response to a solicitation by a contractor/consultant that does not include this completed form shall be deemed non-responsive and rejected.** The form is found at: <https://fs7.formsite.com/CCDenver/form161/index.html>

Using the form found in link listed above, please state whether you have a Diversity and Inclusiveness program for employment and retention, procurement and supply chain activities, or customer service and provide the additional information requested on the form. The information provided on the Diversity and Inclusiveness in City Solicitations Information Request Form will provide an opportunity for City contractors/consultants to describe their own diversity and inclusiveness practices. Contractors/consultants are not expected to conduct intrusive examinations of its employees, managers, or business partners in order to describe diversity and inclusiveness measures. Rather, the City simply seeks a description of the contractor/consultant's current practices, if any. Diversity and Inclusiveness information provided by City contractors/consultants in response to City solicitations for services or goods will be collated, analyzed, and made available in reports consistent with City Executive Order No. 101. However, no personally identifiable information provided by or obtained from contractors/consultants will be in such reports.

**Insert the completed hard copy of the Diversity And Inclusiveness  
In City Solicitations Form immediately following this page.**

**A SIGNED HARD COPY OF THE COMPLETED FORM MUST  
BE INCLUDED IN YOUR BID RESPONSE**

Office of Economic Development Division of Small Business Opportunity 201 W Colfax Ave, Dept 907 Denver, CO 80202 P: 720.913.1714 F: 720.913.1809 www.denvergov.org/oed

Diversity and Inclusiveness\* in City Solicitations Information Request Form Denver Executive Order No. 101 establishes strategies between the City and private industry to use diversity and inclusiveness to promote economic development in the City and County of Denver and to encourage more businesses to compete for City contracts and procurements. The Executive Order requires, among other things, the collection of certain information regarding the practices of the City's contractors and consultants toward diversity and inclusiveness and encourages/requires City agencies to include diversity and inclusiveness policies in selection criteria where legally permitted in solicitations for City services or goods. Answer each question below. Missing or incomplete responses will be recorded as "no", "not applicable", or "none". A proposal or response to a solicitation by a contractor/consultant that does not include this completed form shall be deemed non-responsive and rejected.

**Business Email Address \*****Enter Email Address of City and County of Denver contact person facilitating this solicitation. \*****Please provide the City Agency that is facilitating this solicitation: \*****Agency Name (if not listed above) \*****Project Name \*****Solicitation No. (Check Below if Not Applicable) \*****Item #141** Check Here if Solicitation No. is N/A**Name of Your Company \*****What Industry is Your Business? \*****If Other, Please Tell Us Your Industry: \*****Address \*****City \*****State****Zip Code \***

**Other (if not state, enter country, province, etc. here)**

**Business Phone Number \***

**Business Facsimile Number**



**1. How many employees does your company employ? \***

- 1-10  
 11-50  
 51-100  
 Over 100

1.1. How many of your employees are:

**Number of Full Time: \***

130

**Number of Part Time: \***

0

**2. Do you have a Diversity and Inclusiveness Program? \***

- Yes  
 No

If No, and your company size is less than 10 employees continue to question 10. Complete and sign the form.

If Yes, does it address:

**2.1. Employment and retention? \***

- Yes  
 No

**2.2. Procurement and supply chain activities? \***

- Yes  
 No

**2.3. Customer Service? \***

- Yes  
 No

**3. Provide a detailed narrative of your company's diversity and inclusiveness principles and programs. This may include, for example, (i) diversity and inclusiveness employee training programs, equal opportunity policies, and the budget amount spent on an annual basis for workplace diversity; or (ii) diversity and inclusiveness training and information to improve customer service. (If Not Applicable, please type N/A below) \***

Hamon Infrastructure, Inc.  
Diversity and Inclusiveness Policy

Hamon Infrastructure, Inc. respects, values and celebrates the unique attributes, characteristics and perspectives that make each person who they are. We believe that our strength lies in our diversity among the broad range of people, subcontractors, suppliers, owners and communities we represent and with whom we work. We consider diversity and inclusion a driver of excellence and seek out diversity of participation, thought and action. It is our aim, therefore, that our members, partners, key stakeholders reflect and embrace these core values. Hamon's goal is to positively impact our company and local community by modeling excellence in diversity and inclusion in the following three areas:

**Human Capital**

It is important to support and nurture the employees of Hamon by creating positive workplace environments and structures that enable them to be engaged in their jobs and to challenge them appropriately to support growth.

**Key Stakeholders**

Individuals, organizations and corporations of all types have the potential to offer insight and expertise on a broad range of strategies related to diversity and inclusion initiatives. We are committed to working collaboratively with key stakeholders locally and statewide to strengthen the integrity, impact and relevance of our diversity and inclusiveness program.

**Programs and Resources**

Hamon strives to leverage its programs and services to enhance the construction industry and its efforts to promote diversity and inclusion with an emphasis on:

Standards and Best Practices  
Career Pipeline  
Professional Development

**Definitions**

**Diversity.** The quality of being different or unique at the individual or group level. This includes age; ethnicity; gender; gender identity; language differences; nationality; parental status; physical, mental and developmental abilities; race; religion; sexual orientation; skin color; socio-economic status; education; work and behavioral styles; the perspectives of each individual shaped by their nation, experiences and culture—and more. Even when people appear the same on the outside, they are different.

**Inclusion.** The act of including; a strategy to leverage diversity. Diversity always exists in social systems. Inclusion, on the other hand, must be created. In order to leverage diversity, an environment must be created where people feel supported, listened to and able to do their personal best.

**4. Does your company regularly communicate its diversity and inclusiveness policies to employees? \***

- Yes  
 No

**If you answered Yes to Question 4, how does your company regularly communicate its diversity and inclusiveness policies to employees? (Select all that apply) \***

- Employee Training  
 Pamphlets  
 Public EEO Postings  
 Other

**5. How often do you provide training and diversity and inclusiveness principles? \***

- Monthly
- Quarterly
- Annually
- N/A
- Other

**5.1 What percentage of the total number of employees generally participate? \***

- 0-25%
- 26-50%
- 51-75%
- 76-100%
- N/A

**6. State how you achieve diversity and inclusiveness in supply and procurement activities. This may include, for example, narratives of training programs, equal opportunity policies, diversity or inclusiveness partnership programs, mentoring and outreach programs, and the amount and description of budget spent on an annual basis for procurement and supplier diversity and inclusiveness. (If Not Applicable, please type N/A below) \***

Hamon Infrastructure implements its diversity and inclusion policies in its supply and procurement activities. Hamon seeks out DBE subcontractor and suppliers using the unified DBE list produced by the City and County of Denver. In addition, Hamon seeks out minority-owned businesses to encourage them to apply for DBE status. Hamon also mentors all DBE and minority-owned businesses as needed to assist and support them in successfully performing their work in accordance with project specifications.

**7. Do you have a diversity and inclusiveness committee? \***

- Yes
- No

**7.1 If Yes, how often does it meet? \***

- Monthly
- Quarterly
- Annually
- Other

**7.2. If you responded that you do not have a diversity and inclusiveness committee, describe any plans your company may have to establish such a committee. (If Not Applicable, please type N/A below) \***

**8. Do you have a budget for diversity and inclusiveness efforts? \***

- Yes
- No

**9. Does your company integrate diversity and inclusion competencies into executive/manager performance evaluation plans? \***

- Yes
- No

**10. If you responded that you do not have a diversity and inclusiveness program, describe any plans your company may have to adopt such a program. \***

**11. Would you like information detailing how to implement a Diversity and Inclusiveness program? \***

- Yes
- No

If yes, please email XO101@denvergov.org.

**I attest that the information represented herein is true, correct and complete, to the best of my knowledge. \***

Check Here if the Above Statement is True.

**Name of Person Completing Form \***

MICHAEL D WALTERS

**Today's Date**

11-06-2017

**NOTE: Attach additional sheets or documentation as necessary for a complete response.**

\*"Diversity and inclusiveness program" means a program that invites values, perspectives and contributions of people from diverse backgrounds, and integrates diversity into its hiring and retention policies, training opportunities, and business development methods to provide an equal opportunity for each person to participate, contribute, and succeed within the organization's workplace. "Diversity" encompasses a wide variety of human differences, including differences such as race, age, gender, gender identity, sexual orientation, ethnicity, physical disabilities, appearance, historically underutilized and disadvantaged persons, as well as social identities such as religion, marital status, socio-economic status, lifestyle, education, parental status, geographic background, language ability, and veteran status."

Bidder HAMON INFRASTRUCTURES, INC

**DENVER INTERNATIONAL AIRPORT**

**Pond 001 Expansion  
Contract No. 201737313**

**Bid Data Forms  
EQUAL OPPORTUNITY REPORT STATEMENT**

Each Bidder shall complete and sign the Equal Opportunity Report Statement. A Bid may be considered unresponsive and may be rejected, in the Owner's sole discretion, if the Bidder fails to provide the fully executed Statement or fails to furnish required data. The Bidder shall also, prior to award, furnish such other pertinent information regarding its own employment policies and practices as well as those of its proposed subcontractors as the FAA, the Owner, or the Executive Vice Chairman of the President's Committee may require.

The Bidder shall furnish similar Statements executed by each of its first-tier and second-tier subcontractors and shall obtain similar compliance by such subcontractors, before awarding subcontracts. No subcontract shall be awarded to any non-complying subcontractor.

Equal Opportunity Report Statement  
as Required in 41 CFR 60-1.7(b)

The Bidder shall complete the following statements by checking the appropriate blanks. Failure to complete these blanks may be grounds for rejection of bid:

1. The Bidder has  has not \_\_\_ developed and has on file at each establishment affirmative action programs pursuant to 41 CFR 60-1.40 and 41 CFR 60-2.
2. The Bidder has  has not \_\_\_ participated in any previous contract or subcontract subject to the equal opportunity clause prescribed by Executive Order 11246, as amended.
3. The Bidder has  has not \_\_\_ filed with the Joint Reporting Committee the annual compliance report on Standard Form 100 (EEO-1 Report).
4. The Bidder does  does not \_\_\_ employ fifty or more employees.

Dated: 01/3/17

HAMON INFRASTRUCTURES, INC  
(Name of Bidder)

By: [Signature]

Title: UP

Bidder HAMON INFRASTRUCTURE, INC

**DENVER INTERNATIONAL AIRPORT**

**Pond 001 Expansion  
Contract No. 201737313**

**Bid Data Forms**

**CERTIFICATION OF NON-SEGREGATED FACILITIES  
(Must be completed and submitted with the Bid)**

The Bidder certifies that it does not maintain or provide for its employees any segregated facilities at any of its establishments, and that it does not permit its employees to perform their services at any location under its control, where segregated facilities are maintained. The Bidder certifies further that it will not maintain or provide for its employees segregated facilities at any of its establishments, and that it will not permit its employees to perform their services at any location under its control, where segregated facilities are maintained. The Bidder agrees that a breach of this certification is a violation of the equal opportunity clause in this contract. As used in this certification, the term "segregated facilities" means any waiting rooms, work areas, restrooms and washrooms, restaurants and other eating areas, parking lots, drinking fountains, recreation or entertainment areas, transportation and housing facilities provided for employees which are segregated by explicit directive or are in fact segregated on the basis of race, color, religion, or national origin, because of habit, local custom, or any other reason. The Bidder agrees that (except where it has obtained identical certification from proposed subcontractors for specific time period) it will obtain identical certifications from proposed subcontractors prior to the award of subcontracts exceeding \$10,000 which are not exempt from the provisions of the equal opportunity clause, and that it will retain such certification in its files.

DATED: 11/3/17

HAMON INFRASTRUCTURE, INC  
(Name of Bidder)

By: [Signature]

Title: UP

**HAMON**  
INFRASTRUCTURE

5670 Franklin St.  
Denver, CO 80216  
T (303) 297-0340  
F (303) 296-9601



November 6, 2017

Chief Executive Officer  
Department of Aviation  
City & County of Denver  
DEN South Campus  
7128 North Trussville Street, Unit A  
Denver, CO 80249

RE: Bid proposal for Contract No. 201737313 Pond 001 Expansion

Hamon Infrastructure, Inc. certifies, by submission of this bid, that neither it nor its principals is presently debarred, suspended, proposed for debarment, declared ineligible, or involuntarily excluded from participation in any government contract by any Federal, State, or local government department or agency. It further agrees by submitting its bid that it will include this clause without modification in all lower tier transactions, solicitations, proposals, contracts, and subcontracts.

Respectfully,

**HAMON INFRASTRUCTURE, INC.**

A handwritten signature in blue ink, appearing to read "Michael D. Walters", written over a faint, illegible background.

Michael D. Walters  
Secretary/Treasurer

# W-9

**Please complete the Request for Taxpayer Identification Number  
and Certification (Form W-9) and submit with your bid.  
These pages are not included in the page numbering of this contract document.**



## Request for Taxpayer Identification Number and Certification

**Give Form to the  
 requester. Do not  
 send to the IRS.**

Print or type  
 See Specific instructions on page 2.

|  |   |
|--|---|
| 1 Name (as shown on your income tax return). Name is required on this line; do not leave this line blank.<br><b>HAMON INFRASTRUCTURES, LLC</b>   |   |
| 2 Business name/disregarded entity name, if different from above   |   |
| 3 Check appropriate box for federal tax classification; check only <b>one</b> of the following seven boxes:<br><input type="checkbox"/> Individual/sole proprietor or single-member LLC <input type="checkbox"/> C Corporation <input checked="" type="checkbox"/> S Corporation <input type="checkbox"/> Partnership <input type="checkbox"/> Trust/estate<br><input type="checkbox"/> Limited liability company. Enter the tax classification (C=C corporation, S=S corporation, P=partnership) ▶ _____<br><b>Note.</b> For a single-member LLC that is disregarded, do not check LLC; check the appropriate box in the line above for the tax classification of the single-member owner.<br><input type="checkbox"/> Other (see instructions) ▶ _____ |   |
| 4 Exemptions (codes apply only to certain entities, not individuals; see instructions on page 3):<br>Exempt payee code (if any) <b>5</b><br>Exemption from FATCA reporting code (if any) _____<br><small>(Applies to accounts maintained outside the U.S.)</small>   |   |
| 5 Address (number, street, and apt. or suite no.)<br><b>5670 FRANKLIN ST</b>   | Requester's name and address (optional) |
| 6 City, state, and ZIP code<br><b>DENVER CO 80214</b>  |   |
| 7 List account number(s) here (optional)   |   |

### Part I Taxpayer Identification Number (TIN)

Enter your TIN in the appropriate box. The TIN provided must match the name given on line 1 to avoid backup withholding. For individuals, this is generally your social security number (SSN). However, for a resident alien, sole proprietor, or disregarded entity, see the Part I instructions on page 3. For other entities, it is your employer identification number (EIN). If you do not have a number, see *How to get a TIN* on page 3.

**Note.** If the account is in more than one name, see the instructions for line 1 and the chart on page 4 for guidelines on whose number to enter.

|   |  |
|---|--|
| <b>Social security number</b>           |  |
| [ ] [ ] [ ] - [ ] [ ] - [ ] [ ] [ ] [ ] |  |
| <b>or</b>                               |  |
| <b>Employer identification number</b>   |  |
| 84 - 1129267                            |  |

### Part II Certification

Under penalties of perjury, I certify that:

- The number shown on this form is my correct taxpayer identification number (or I am waiting for a number to be issued to me); and
- I am not subject to backup withholding because: (a) I am exempt from backup withholding, or (b) I have not been notified by the Internal Revenue Service (IRS) that I am subject to backup withholding as a result of a failure to report all interest or dividends, or (c) the IRS has notified me that I am no longer subject to backup withholding; and
- I am a U.S. citizen or other U.S. person (defined below); and
- The FATCA code(s) entered on this form (if any) indicating that I am exempt from FATCA reporting is correct.

**Certification instructions.** You must cross out item 2 above if you have been notified by the IRS that you are currently subject to backup withholding because you have failed to report all interest and dividends on your tax return. For real estate transactions, item 2 does not apply. For mortgage interest paid, acquisition or abandonment of secured property, cancellation of debt, contributions to an individual retirement arrangement (IRA), and generally, payments other than interest and dividends, you are not required to sign the certification, but you must provide your correct TIN. See the instructions on page 3.

|                  |                            |    |                |
|------------------|----------------------------|----|----------------|
| <b>Sign Here</b> | Signature of U.S. person ▶ | VP | Date ▶ 11/3/17 |
|------------------|----------------------------|----|----------------|

### General Instructions

Section references are to the Internal Revenue Code unless otherwise noted.

**Future developments.** Information about developments affecting Form W-9 (such as legislation enacted after we release it) is at [www.irs.gov/fw9](http://www.irs.gov/fw9).

#### Purpose of Form

An individual or entity (Form W-9 requester) who is required to file an information return with the IRS must obtain your correct taxpayer identification number (TIN) which may be your social security number (SSN), individual taxpayer identification number (ITIN), adoption taxpayer identification number (ATIN), or employer identification number (EIN), to report on an information return the amount paid to you, or other amount reportable on an information return. Examples of information returns include, but are not limited to, the following:

- Form 1099-INT (interest earned or paid)
- Form 1099-DIV (dividends, including those from stocks or mutual funds)
- Form 1099-MISC (various types of income, prizes, awards, or gross proceeds)
- Form 1099-B (stock or mutual fund sales and certain other transactions by brokers)
- Form 1099-S (proceeds from real estate transactions)
- Form 1099-K (merchant card and third party network transactions)

- Form 1098 (home mortgage interest), 1098-E (student loan interest), 1098-T (tuition)

- Form 1099-C (canceled debt)

- Form 1099-A (acquisition or abandonment of secured property)

Use Form W-9 only if you are a U.S. person (including a resident alien), to provide your correct TIN.

*If you do not return Form W-9 to the requester with a TIN, you might be subject to backup withholding. See What is backup withholding? on page 2.*

By signing the filled-out form, you:

- Certify that the TIN you are giving is correct (or you are waiting for a number to be issued),
- Certify that you are not subject to backup withholding, or
- Claim exemption from backup withholding if you are a U.S. exempt payee. If applicable, you are also certifying that as a U.S. person, your allocable share of any partnership income from a U.S. trade or business is not subject to the withholding tax on foreign partners' share of effectively connected income, and
- Certify that FATCA code(s) entered on this form (if any) indicating that you are exempt from the FATCA reporting, is correct. See *What is FATCA reporting?* on page 2 for further information.

**Note.** If you are a U.S. person and a requester gives you a form other than Form W-9 to request your TIN, you must use the requester's form if it is substantially similar to this Form W-9.

**Definition of a U.S. person.** For federal tax purposes, you are considered a U.S. person if you are:

- An individual who is a U.S. citizen or U.S. resident alien;
- A partnership, corporation, company, or association created or organized in the United States or under the laws of the United States;
- An estate (other than a foreign estate); or
- A domestic trust (as defined in Regulations section 301.7701-7).

**Special rules for partnerships.** Partnerships that conduct a trade or business in the United States are generally required to pay a withholding tax under section 1446 on any foreign partners' share of effectively connected taxable income from such business. Further, in certain cases where a Form W-9 has not been received, the rules under section 1446 require a partnership to presume that a partner is a foreign person, and pay the section 1446 withholding tax. Therefore, if you are a U.S. person that is a partner in a partnership conducting a trade or business in the United States, provide Form W-9 to the partnership to establish your U.S. status and avoid section 1446 withholding on your share of partnership income.

In the cases below, the following person must give Form W-9 to the partnership for purposes of establishing its U.S. status and avoiding withholding on its allocable share of net income from the partnership conducting a trade or business in the United States:

- In the case of a disregarded entity with a U.S. owner, the U.S. owner of the disregarded entity and not the entity;
- In the case of a grantor trust with a U.S. grantor or other U.S. owner, generally, the U.S. grantor or other U.S. owner of the grantor trust and not the trust; and
- In the case of a U.S. trust (other than a grantor trust), the U.S. trust (other than a grantor trust) and not the beneficiaries of the trust.

**Foreign person.** If you are a foreign person or the U.S. branch of a foreign bank that has elected to be treated as a U.S. person, do not use Form W-9. Instead, use the appropriate Form W-8 or Form 8233 (see Publication 515, Withholding of Tax on Nonresident Aliens and Foreign Entities).

**Nonresident alien who becomes a resident alien.** Generally, only a nonresident alien individual may use the terms of a tax treaty to reduce or eliminate U.S. tax on certain types of income. However, most tax treaties contain a provision known as a "saving clause." Exceptions specified in the saving clause may permit an exemption from tax to continue for certain types of income even after the payee has otherwise become a U.S. resident alien for tax purposes.

If you are a U.S. resident alien who is relying on an exception contained in the saving clause of a tax treaty to claim an exemption from U.S. tax on certain types of income, you must attach a statement to Form W-9 that specifies the following five items:

1. The treaty country. Generally, this must be the same treaty under which you claimed exemption from tax as a nonresident alien.
2. The treaty article addressing the income.
3. The article number (or location) in the tax treaty that contains the saving clause and its exceptions.
4. The type and amount of income that qualifies for the exemption from tax.
5. Sufficient facts to justify the exemption from tax under the terms of the treaty article.

**Example.** Article 20 of the U.S.-China income tax treaty allows an exemption from tax for scholarship income received by a Chinese student temporarily present in the United States. Under U.S. law, this student will become a resident alien for tax purposes if his or her stay in the United States exceeds 5 calendar years. However, paragraph 2 of the first Protocol to the U.S.-China treaty (dated April 30, 1984) allows the provisions of Article 20 to continue to apply even after the Chinese student becomes a resident alien of the United States. A Chinese student who qualifies for this exception (under paragraph 2 of the first protocol) and is relying on this exception to claim an exemption from tax on his or her scholarship or fellowship income would attach to Form W-9 a statement that includes the information described above to support that exemption.

If you are a nonresident alien or a foreign entity, give the requester the appropriate completed Form W-8 or Form 8233.

## Backup Withholding

**What is backup withholding?** Persons making certain payments to you must under certain conditions withhold and pay to the IRS 28% of such payments. This is called "backup withholding." Payments that may be subject to backup withholding include interest, tax-exempt interest, dividends, broker and barter exchange transactions, rents, royalties, nonemployee pay, payments made in settlement of payment card and third party network transactions, and certain payments from fishing boat operators. Real estate transactions are not subject to backup withholding.

You will not be subject to backup withholding on payments you receive if you give the requester your correct TIN, make the proper certifications, and report all your taxable interest and dividends on your tax return.

**Payments you receive will be subject to backup withholding if:**

1. You do not furnish your TIN to the requester,
2. You do not certify your TIN when required (see the Part II instructions on page 3 for details),

3. The IRS tells the requester that you furnished an incorrect TIN,

4. The IRS tells you that you are subject to backup withholding because you did not report all your interest and dividends on your tax return (for reportable interest and dividends only), or

5. You do not certify to the requester that you are not subject to backup withholding under 4 above (for reportable interest and dividend accounts opened after 1983 only).

Certain payees and payments are exempt from backup withholding. See *Exempt payee code* on page 3 and the separate Instructions for the Requester of Form W-9 for more information.

Also see *Special rules for partnerships* above.

## What is FATCA reporting?

The Foreign Account Tax Compliance Act (FATCA) requires a participating foreign financial institution to report all United States account holders that are specified United States persons. Certain payees are exempt from FATCA reporting. See *Exemption from FATCA reporting code* on page 3 and the Instructions for the Requester of Form W-9 for more information.

## Updating Your Information

You must provide updated information to any person to whom you claimed to be an exempt payee if you are no longer an exempt payee and anticipate receiving reportable payments in the future from this person. For example, you may need to provide updated information if you are a C corporation that elects to be an S corporation, or if you no longer are tax exempt. In addition, you must furnish a new Form W-9 if the name or TIN changes for the account; for example, if the grantor of a grantor trust dies.

## Penalties

**Failure to furnish TIN.** If you fail to furnish your correct TIN to a requester, you are subject to a penalty of \$50 for each such failure unless your failure is due to reasonable cause and not to willful neglect.

**Civil penalty for false information with respect to withholding.** If you make a false statement with no reasonable basis that results in no backup withholding, you are subject to a \$500 penalty.

**Criminal penalty for falsifying information.** Willfully falsifying certifications or affirmations may subject you to criminal penalties including fines and/or imprisonment.

**Misuse of TINs.** If the requester discloses or uses TINs in violation of federal law, the requester may be subject to civil and criminal penalties.

## Specific Instructions

### Line 1

You must enter one of the following on this line; **do not** leave this line blank. The name should match the name on your tax return.

If this Form W-9 is for a joint account, list first, and then circle, the name of the person or entity whose number you entered in Part I of Form W-9.

a. **Individual.** Generally, enter the name shown on your tax return. If you have changed your last name without informing the Social Security Administration (SSA) of the name change, enter your first name, the last name as shown on your social security card, and your new last name.

**Note. ITIN applicant:** Enter your individual name as it was entered on your Form W-7 application, line 1a. This should also be the same as the name you entered on the Form 1040/1040A/1040EZ you filed with your application.

b. **Sole proprietor or single-member LLC.** Enter your individual name as shown on your 1040/1040A/1040EZ on line 1. You may enter your business, trade, or "doing business as" (DBA) name on line 2.

c. **Partnership, LLC that is not a single-member LLC, C Corporation, or S Corporation.** Enter the entity's name as shown on the entity's tax return on line 1 and any business, trade, or DBA name on line 2.

d. **Other entities.** Enter your name as shown on required U.S. federal tax documents on line 1. This name should match the name shown on the charter or other legal document creating the entity. You may enter any business, trade, or DBA name on line 2.

e. **Disregarded entity.** For U.S. federal tax purposes, an entity that is disregarded as an entity separate from its owner is treated as a "disregarded entity." See Regulations section 301.7701-2(c)(2)(iii). Enter the owner's name on line 1. The name of the entity entered on line 1 should never be a disregarded entity. The name on line 1 should be the name shown on the income tax return on which the income should be reported. For example, if a foreign LLC that is treated as a disregarded entity for U.S. federal tax purposes has a single owner that is a U.S. person, the U.S. owner's name is required to be provided on line 1. If the direct owner of the entity is also a disregarded entity, enter the first owner that is not disregarded for federal tax purposes. Enter the disregarded entity's name on line 2, "Business name/disregarded entity name." If the owner of the disregarded entity is a foreign person, the owner must complete an appropriate Form W-8 instead of a Form W-9. This is the case even if the foreign person has a U.S. TIN.

**Line 2**

If you have a business name, trade name, DBA name, or disregarded entity name, you may enter it on line 2.

**Line 3**

Check the appropriate box in line 3 for the U.S. federal tax classification of the person whose name is entered on line 1. Check only one box in line 3.

**Limited Liability Company (LLC).** If the name on line 1 is an LLC treated as a partnership for U.S. federal tax purposes, check the "Limited Liability Company" box and enter "P" in the space provided. If the LLC has filed Form 8832 or 2553 to be taxed as a corporation, check the "Limited Liability Company" box and in the space provided enter "C" for C corporation or "S" for S corporation. If it is a single-member LLC that is a disregarded entity, do not check the "Limited Liability Company" box; instead check the first box in line 3 "Individual/sole proprietor or single-member LLC."

**Line 4, Exemptions**

If you are exempt from backup withholding and/or FATCA reporting, enter in the appropriate space in line 4 any code(s) that may apply to you.

**Exempt payee code.**

- Generally, individuals (including sole proprietors) are not exempt from backup withholding.
- Except as provided below, corporations are exempt from backup withholding for certain payments, including interest and dividends.
- Corporations are not exempt from backup withholding for payments made in settlement of payment card or third party network transactions.
- Corporations are not exempt from backup withholding with respect to attorneys' fees or gross proceeds paid to attorneys, and corporations that provide medical or health care services are not exempt with respect to payments reportable on Form 1099-MISC.

The following codes identify payees that are exempt from backup withholding. Enter the appropriate code in the space in line 4.

- 1—An organization exempt from tax under section 501(a), any IRA, or a custodial account under section 403(b)(7) if the account satisfies the requirements of section 401(f)(2)
- 2—The United States or any of its agencies or instrumentalities
- 3—A state, the District of Columbia, a U.S. commonwealth or possession, or any of their political subdivisions or instrumentalities
- 4—A foreign government or any of its political subdivisions, agencies, or instrumentalities
- 5—A corporation
- 6—A dealer in securities or commodities required to register in the United States, the District of Columbia, or a U.S. commonwealth or possession
- 7—A futures commission merchant registered with the Commodity Futures Trading Commission
- 8—A real estate investment trust
- 9—An entity registered at all times during the tax year under the Investment Company Act of 1940
- 10—A common trust fund operated by a bank under section 584(a)
- 11—A financial institution
- 12—A middleman known in the investment community as a nominee or custodian
- 13—A trust exempt from tax under section 664 or described in section 4947

The following chart shows types of payments that may be exempt from backup withholding. The chart applies to the exempt payees listed above, 1 through 13.

| IF the payment is for . . .  | THEN the payment is exempt for . . .  |
|--|---|
| Interest and dividend payments   | All exempt payees except for 7  |
| Broker transactions  | Exempt payees 1 through 4 and 6 through 11 and all C corporations. S corporations must not enter an exempt payee code because they are exempt only for sales of noncovered securities acquired prior to 2012. |
| Barter exchange transactions and patronage dividends                                   | Exempt payees 1 through 4   |
| Payments over \$600 required to be reported and direct sales over \$5,000 <sup>1</sup> | Generally, exempt payees 1 through 5 <sup>2</sup>   |
| Payments made in settlement of payment card or third party network transactions        | Exempt payees 1 through 4   |

<sup>1</sup> See Form 1099-MISC, Miscellaneous Income, and its instructions.

<sup>2</sup> However, the following payments made to a corporation and reportable on Form 1099-MISC are not exempt from backup withholding: medical and health care payments, attorneys' fees, gross proceeds paid to an attorney reportable under section 6045(f), and payments for services paid by a federal executive agency.

**Exemption from FATCA reporting code.** The following codes identify payees that are exempt from reporting under FATCA. These codes apply to persons submitting this form for accounts maintained outside of the United States by certain foreign financial institutions. Therefore, if you are only submitting this form for an account you hold in the United States, you may leave this field blank. Consult with the person requesting this form if you are uncertain if the financial institution is subject to these requirements. A requester may indicate that a code is not required by providing you with a Form W-9 with "Not Applicable" (or any similar indication) written or printed on the line for a FATCA exemption code.

- A—An organization exempt from tax under section 501(a) or any individual retirement plan as defined in section 7701(a)(37)
- B—The United States or any of its agencies or instrumentalities
- C—A state, the District of Columbia, a U.S. commonwealth or possession, or any of their political subdivisions or instrumentalities
- D—A corporation the stock of which is regularly traded on one or more established securities markets, as described in Regulations section 1.1472-1(c)(1)(i)
- E—A corporation that is a member of the same expanded affiliated group as a corporation described in Regulations section 1.1472-1(c)(1)(i)
- F—A dealer in securities, commodities, or derivative financial instruments (including notional principal contracts, futures, forwards, and options) that is registered as such under the laws of the United States or any state
- G—A real estate investment trust
- H—A regulated investment company as defined in section 851 or an entity registered at all times during the tax year under the Investment Company Act of 1940
- I—A common trust fund as defined in section 584(a)
- J—A bank as defined in section 581
- K—A broker
- L—A trust exempt from tax under section 664 or described in section 4947(a)(1)
- M—A tax exempt trust under a section 403(b) plan or section 457(g) plan

**Note.** You may wish to consult with the financial institution requesting this form to determine whether the FATCA code and/or exempt payee code should be completed.

**Line 5**

Enter your address (number, street, and apartment or suite number). This is where the requester of this Form W-9 will mail your information returns.

**Line 6**

Enter your city, state, and ZIP code.

**Part I. Taxpayer Identification Number (TIN)**

**Enter your TIN in the appropriate box.** If you are a resident alien and you do not have and are not eligible to get an SSN, your TIN is your IRS individual taxpayer identification number (ITIN). Enter it in the social security number box. If you do not have an ITIN, see *How to get a TIN* below.

If you are a sole proprietor and you have an EIN, you may enter either your SSN or EIN. However, the IRS prefers that you use your SSN.

If you are a single-member LLC that is disregarded as an entity separate from its owner (see *Limited Liability Company (LLC)* on this page), enter the owner's SSN (or EIN, if the owner has one). Do not enter the disregarded entity's EIN. If the LLC is classified as a corporation or partnership, enter the entity's EIN.

**Note.** See the chart on page 4 for further clarification of name and TIN combinations.

**How to get a TIN.** If you do not have a TIN, apply for one immediately. To apply for an SSN, get Form SS-5, Application for a Social Security Card, from your local SSA office or get this form online at [www.ssa.gov](http://www.ssa.gov). You may also get this form by calling 1-800-772-1213. Use Form W-7, Application for IRS Individual Taxpayer Identification Number, to apply for an ITIN, or Form SS-4, Application for Employer Identification Number, to apply for an EIN. You can apply for an EIN online by accessing the IRS website at [www.irs.gov/businesses](http://www.irs.gov/businesses) and clicking on Employer Identification Number (EIN) under Starting a Business. You can get Forms W-7 and SS-4 from the IRS by visiting [IRS.gov](http://IRS.gov) or by calling 1-800-TAX-FORM (1-800-829-3676).

If you are asked to complete Form W-9 but do not have a TIN, apply for a TIN and write "Applied For" in the space for the TIN, sign and date the form, and give it to the requester. For interest and dividend payments, and certain payments made with respect to readily tradable instruments, generally you will have 60 days to get a TIN and give it to the requester before you are subject to backup withholding on payments. The 60-day rule does not apply to other types of payments. You will be subject to backup withholding on all such payments until you provide your TIN to the requester.

**Note.** Entering "Applied For" means that you have already applied for a TIN or that you intend to apply for one soon.

**Caution:** A disregarded U.S. entity that has a foreign owner must use the appropriate Form W-8.

**Part II. Certification**

To establish to the withholding agent that you are a U.S. person, or resident alien, sign Form W-9. You may be requested to sign by the withholding agent even if items 1, 4, or 5 below indicate otherwise.

For a joint account, only the person whose TIN is shown in Part I should sign (when required). In the case of a disregarded entity, the person identified on line 1 must sign. Exempt payees, see *Exempt payee code* earlier.

**Signature requirements.** Complete the certification as indicated in items 1 through 5 below.

**1. Interest, dividend, and barter exchange accounts opened before 1984 and broker accounts considered active during 1983.** You must give your correct TIN, but you do not have to sign the certification.

**2. Interest, dividend, broker, and barter exchange accounts opened after 1983 and broker accounts considered inactive during 1983.** You must sign the certification or backup withholding will apply. If you are subject to backup withholding and you are merely providing your correct TIN to the requester, you must cross out item 2 in the certification before signing the form.

**3. Real estate transactions.** You must sign the certification. You may cross out item 2 of the certification.

**4. Other payments.** You must give your correct TIN, but you do not have to sign the certification unless you have been notified that you have previously given an incorrect TIN. "Other payments" include payments made in the course of the requester's trade or business for rents, royalties, goods (other than bills for merchandise), medical and health care services (including payments to corporations), payments to a nonemployee for services, payments made in settlement of payment card and third party network transactions, payments to certain fishing boat crew members and fishermen, and gross proceeds paid to attorneys (including payments to corporations).

**5. Mortgage interest paid by you, acquisition or abandonment of secured property, cancellation of debt, qualified tuition program payments (under section 529), IRA, Coverdell ESA, Archer MSA or HSA contributions or distributions, and pension distributions.** You must give your correct TIN, but you do not have to sign the certification.

**What Name and Number To Give the Requester**

| For this type of account:  | Give name and SSN of:   |
|--|---|
| 1. Individual  | The individual  |
| 2. Two or more individuals (joint account)   | The actual owner of the account or, if combined funds, the first individual on the account <sup>1</sup> |
| 3. Custodian account of a minor (Uniform Gift to Minors Act)   | The minor <sup>2</sup>  |
| 4. a. The usual revocable savings trust (grantor is also trustee)<br>b. So-called trust account that is not a legal or valid trust under state law | The grantor-trustee <sup>1</sup><br><br>The actual owner <sup>1</sup>                                   |
| 5. Sole proprietorship or disregarded entity owned by an individual  | The owner <sup>2</sup>  |
| 6. Grantor trust filing under Optional Form 1099 Filing Method 1 (see Regulations section 1.671-4(b)(2)(i)(A))                                     | The grantor <sup>*</sup>  |

| For this type of account:   | Give name and EIN of:     |
|---|---------------------------|
| 7. Disregarded entity not owned by an individual  | The owner                 |
| 8. A valid trust, estate, or pension trust  | Legal entity <sup>4</sup> |
| 9. Corporation or LLC electing corporate status on Form 8832 or Form 2553   | The corporation           |
| 10. Association, club, religious, charitable, educational, or other tax-exempt organization   | The organization          |
| 11. Partnership or multi-member LLC   | The partnership           |
| 12. A broker or registered nominee  | The broker or nominee     |
| 13. Account with the Department of Agriculture in the name of a public entity (such as a state or local government, school district, or prison) that receives agricultural program payments | The public entity         |
| 14. Grantor trust filing under the Form 1041 Filing Method or the Optional Form 1099 Filing Method 2 (see Regulations section 1.671-4(b)(2)(i)(B))  | The trust                 |

<sup>1</sup> List first and circle the name of the person whose number you furnish. If only one person on a joint account has an SSN, that person's number must be furnished.

<sup>2</sup> Circle the minor's name and furnish the minor's SSN.

<sup>3</sup> You must show your individual name and you may also enter your business or DBA name on the "Business name/disregarded entity" name line. You may use either your SSN or EIN (if you have one), but the IRS encourages you to use your SSN.

<sup>4</sup> List first and circle the name of the trust, estate, or pension trust. (Do not furnish the TIN of the personal representative or trustee unless the legal entity itself is not designated in the account title.) Also see *Special rules for partnerships* on page 2.

**\*Note.** Grantor also must provide a Form W-9 to trustee of trust.

**Note.** If no name is circled when more than one name is listed, the number will be considered to be that of the first name listed.

**Secure Your Tax Records from Identity Theft**

Identity theft occurs when someone uses your personal information such as your name, SSN, or other identifying information, without your permission, to commit fraud or other crimes. An identity thief may use your SSN to get a job or may file a tax return using your SSN to receive a refund.

To reduce your risk:

- Protect your SSN,
- Ensure your employer is protecting your SSN, and
- Be careful when choosing a tax preparer.

If your tax records are affected by identity theft and you receive a notice from the IRS, respond right away to the name and phone number printed on the IRS notice or letter.

If your tax records are not currently affected by identity theft but you think you are at risk due to a lost or stolen purse or wallet, questionable credit card activity or credit report, contact the IRS Identity Theft Hotline at 1-800-908-4490 or submit Form 14039.

For more information, see Publication 4535, Identity Theft Prevention and Victim Assistance.

Victims of identity theft who are experiencing economic harm or a system problem, or are seeking help in resolving tax problems that have not been resolved through normal channels, may be eligible for Taxpayer Advocate Service (TAS) assistance. You can reach TAS by calling the TAS toll-free case intake line at 1-877-777-4778 or TTY/TDD 1-800-829-4059.

**Protect yourself from suspicious emails or phishing schemes.** Phishing is the creation and use of email and websites designed to mimic legitimate business emails and websites. The most common act is sending an email to a user falsely claiming to be an established legitimate enterprise in an attempt to scam the user into surrendering private information that will be used for identity theft.

The IRS does not initiate contacts with taxpayers via emails. Also, the IRS does not request personal detailed information through email or ask taxpayers for the PIN numbers, passwords, or similar secret access information for their credit card, bank, or other financial accounts.

If you receive an unsolicited email claiming to be from the IRS, forward this message to [phishing@irs.gov](mailto:phishing@irs.gov). You may also report misuse of the IRS name, logo, or other IRS property to the Treasury Inspector General for Tax Administration (TIGTA) at 1-800-366-4484. You can forward suspicious emails to the Federal Trade Commission at: [spam@uce.gov](mailto:spam@uce.gov) or contact them at [www.ftc.gov/idtheft](http://www.ftc.gov/idtheft) or 1-877-IDTHEFT (1-877-438-4338).

Visit [IRS.gov](http://IRS.gov) to learn more about identity theft and how to reduce your risk.

**Privacy Act Notice**

Section 6109 of the Internal Revenue Code requires you to provide your correct TIN to persons (including federal agencies) who are required to file information returns with the IRS to report interest, dividends, or certain other income paid to you; mortgage interest you paid; the acquisition or abandonment of secured property; the cancellation of debt; or contributions you made to an IRA, Archer MSA, or HSA. The person collecting this form uses the information on the form to file information returns with the IRS, reporting the above information. Routine uses of this information include giving it to the Department of Justice for civil and criminal litigation and to cities, states, the District of Columbia, and U.S. commonwealths and possessions for use in administering their laws. The information also may be disclosed to other countries under a treaty, to federal and state agencies to enforce civil and criminal laws, or to federal law enforcement and intelligence agencies to combat terrorism. You must provide your TIN whether or not you are required to file a tax return. Under section 3406, payers must generally withhold a percentage of taxable interest, dividend, and certain other payments to a payee who does not give a TIN to the payer. Certain penalties may also apply for providing false or fraudulent information.

# **DSBO FORMS**

**The DSBO forms which apply to this contract are contained in the pages immediately following this page. These pages are not included in the numbering of this contract document.**



## COMMITMENT TO MWBE PARTICIPATION

Office of Economic Development  
Division of Small Business Opportunity

Denver International Airport  
Airport Office Building, Suite 7810  
8500 Pena Blvd  
Denver, CO 80249  
Phone: 303-342-2180 Fax: 303-342-2190  
E-mail: small.business@flydenver.com

*The undersigned has satisfied the MWBE participant requirements in the following manner ( Please check the appropriate box):*

Contract # 201737313 Contract Name: POND 001 EXPANSION



The Bidder/Proposer is committed to the minimum advertised contract goal for MWBE utilization on the contract, and will submit Letters of Intent (LOI) for each subcontractor/subconsultant/supplier listed for participation in the Bid Forms as follows:

Hard Bids: Three (3) business days after the bid opening  
Request for Proposals: With the proposal when due  
Compliance Plans: With each task/work order



The Bidder/Proposer is unable to meet the contract goal of \_\_\_\_\_ % MWBE, but is committed to a minimum of \_\_\_\_\_ % MWBE utilization on the contract. The Bidder/Proposer understands that they must submit a detailed statement of their Good Faith Effort (GFE) in accordance with DRMC Section 28-62 and 28-67 of Ordinance 85 Part 26 and must submit Letters of Intent for each MWBE listed for participation in the Bid Forms as follows:

Hard Bids: Three (3) business days after the bid opening  
Request for Proposals: With the proposal when due  
Compliance Plans: With each task/work order



The Bidder/Proposer is a certified MWBE in good standing with the City and County of Denver and is committed to self-perform a minimum of \_\_\_\_\_ % of the work on the contract.

|                                       |                         |   |                     |           |   |
|---------------------------------------|-------------------------|---|---------------------|-----------|---|
| Bidder/Proposer (Name of Firm):       |                         | <u>HAMON INFRASTRUCTURE, INC</u>  |                     |           |   |
| Firm's Representative (Please Print): |                         | <u>MICHAEL D. WALTERS</u>   |                     |           |   |
| Signature (Firm's Representative):    |                         |  |                     | Date:     | <u>11/3/16</u>                          |
| Title:                                | <u>VP/SEC/TREAS</u>     |   |                     |           |   |
| Address:                              | <u>5670 FRANKLIN ST</u> |   |                     |           |   |
| City:                                 | <u>DENVER</u>           | State:  | <u>CO</u>           | Zip Code: | <u>80214</u>                            |
| Phone:                                | <u>303-297-0340</u>     | Fax:  | <u>303-296-9601</u> | E-mail:   | <u>MWALTERS@HAMONINFRASTRUCTURE.COM</u> |



**List of Proposed  
MWBE  
Bidders, Subcontractors,  
Suppliers, Manufacturers, or Brokers**

Office of Economic Development  
Division of Small Business Opportunity

Denver International Airport  
Airport Office Building, Suite 7810  
8500 Pena Blvd  
Denver, CO 80249  
Phone: 303-342-2180 Fax: 303-342-2190  
E-mail: small.business@flydenver.com

|            |           |       |         |
|------------|-----------|-------|---------|
| Contract # | 201737313 | Date: | 11/3/17 |
|------------|-----------|-------|---------|

|                |                    |
|----------------|--------------------|
| Contract Name: | POND COI EXPANSION |
|----------------|--------------------|

The undersigned proposes to utilize the following MWBEs for the contract. All Listed firms are CURRENTLY certified by the City and County of Denver. Only the level of MWBE participation listed at the bid opening will count toward satisfaction of the contract goal. Only bona fide commissions may be counted for Brokers. MWBE prime proposers must detail their bid information below. Please copy and attach this page to list additional MWBE participation.

The undersigned bidder hereby certifies that the subcontractors and suppliers listed below have full knowledge that their names have been offered as subcontractors and suppliers for the work, and the bidder further certifies that the dollar amount of work to be performed by the MWBE was furnished to the bidder prior to the bid opening.

| Prime          |                                   |                 |             |
|----------------|-----------------------------------|-----------------|-------------|
| Business Name: | HAMON CONTRACTORS, INC            | Contact Person: | MIKE WATSON |
| Address:       | 5670 FRANKLIN ST DENVER, CO 80216 | \$ Amount:      | \$ 070,000  |
| Scope of Work: | PRIME CONTRACTOR - GRADING, ETC   | % of Contract:  | 100%        |

| Certified MWBE Prime |  |                 |  |
|----------------------|--|-----------------|--|
| Business Name:       |  | Contact Person: |  |
| Address:             |  | \$ Amount:      |  |
| Scope of Work:       |  | % of Contract:  |  |

| Subcontractors, Suppliers, Manufacturers, or Brokers (check one box) |  |                                       |                                 |
|--|--|---------------------------------------|---------------------------------|
| Subcontractor <input checked="" type="checkbox"/>                    | Supplier <input type="checkbox"/>          | Manufacturer <input type="checkbox"/> | Broker <input type="checkbox"/> |
| Business Name:   | LOBATO CONSTRUCTION LLC                    | Contact Person:                       | TIM LOBATO                      |
| Address:   | 1333 W 120TH AVE #110 WESTMINSTER CO 80540 | \$ Amount:                            | 700,000                         |
| Scope of Work:   | CONCRETE PAVEMENT, FINISHING, ROOFING      | % of Contract:                        | 13.8                            |

| Subcontractors, Suppliers, Manufacturers, or Brokers (check one box) |                                   |                                       |                                 |
|--|-----------------------------------|---------------------------------------|---------------------------------|
| Subcontractor <input type="checkbox"/>                               | Supplier <input type="checkbox"/> | Manufacturer <input type="checkbox"/> | Broker <input type="checkbox"/> |
| Business Name:   |                                   | Contact Person:                       |                                 |
| Address:   |                                   | \$ Amount:                            |                                 |
| Scope of Work:   |                                   | % of Contract:                        |                                 |

| Subcontractors, Suppliers, Manufacturers, or Brokers (check one box) |                                   |                                       |                                 |
|--|-----------------------------------|---------------------------------------|---------------------------------|
| Subcontractor <input type="checkbox"/>                               | Supplier <input type="checkbox"/> | Manufacturer <input type="checkbox"/> | Broker <input type="checkbox"/> |
| Business Name:   |                                   | Contact Person:                       |                                 |
| Address:   |                                   | \$ Amount:                            |                                 |
| Scope of Work:   |                                   | % of Contract:                        |                                 |

| Subcontractors, Suppliers, Manufacturers, or Brokers (check one box) |                                   |                                       |                                 |
|--|-----------------------------------|---------------------------------------|---------------------------------|
| Subcontractor <input type="checkbox"/>                               | Supplier <input type="checkbox"/> | Manufacturer <input type="checkbox"/> | Broker <input type="checkbox"/> |
| Business Name:   |                                   | Contact Person:                       |                                 |
| Address:   |                                   | \$ Amount:                            |                                 |
| Scope of Work:   |                                   | % of Contract:                        |                                 |

Bidder Hamon Infrastructure, Inc.

**DENVER INTERNATIONAL AIRPORT  
Pond 001 Expansion  
Contract No. 201737313**

**Bid Bond**

KNOW ALL MEN BY THESE PRESENTS

THAT Hamon Infrastructure, Inc. \*, as Principal, and Great American Insurance Company \*\*, a corporation organized and existing under and by virtue of the laws of the State of OH, and authorized to do business within the State of Colorado as Surety, are held and firmly bound unto the City and County of Denver, Colorado, as Obligees, in the full and just sum of Five Percent of Amount Bid--- Dollars and ----- Cents (\$5%---) lawful money of the United States, for the payment of which sum, well and truly to be made, we bind ourselves, our heirs, executors, administrators, successors and assigns, jointly and severally, firmly by these presents:

WHEREAS, the said Principal is herewith submitting its Bid, dated on November 3, 2017, for the construction of Contract No. **201737313, Pond 001 Expansion**, Denver International Airport, as set forth in detail in the contract documents for the City and County of Denver, Colorado, and said Obligees has required as a condition for receiving said Bid that the Principal deposit specified bid security in the amount of not less than five percent (5%) of the amount of said Bid, as it relates to work to be performed for the City, conditioned that in event of failure of the Principal to execute the Contract for such construction and furnish required Performance and Payment Bond if the Contract is offered him, that said sum be paid immediately to the Obligees as liquidated damages, and not as a Penalty, for the Principal's failure to perform.

The condition of this obligation is such that if the aforesaid Principal shall, within the period specified therefor, on the prescribed form presented to him for signature, enter into a written Contract with the Obligees in accordance with his bid as accepted, and give Performance and Payment Bond with good and sufficient surety or sureties, upon the form prescribed by the Obligees, for the faithful performance and the proper fulfillment of said Contract, or in the event of withdrawal of said bid within the time specified, or upon the payment to the Obligees of the sum determined upon herein, as liquidated damages and not as a Penalty, in the event the Principal fails to enter into said Contract and give such Performance and Payment Bond within the time specified, then this Obligation shall be null and void, otherwise to remain in full force and effect.

[END OF PAGE]



**GREAT AMERICAN INSURANCE COMPANY®**

**Administrative Office: 301 E 4TH STREET • CINCINNATI, OHIO 45202 • 513-369-5000 • FAX 513-723-2740**

The number of persons authorized by this power of attorney is not more than ONE

Bond No. Bid Bond

**POWER OF ATTORNEY**

**KNOW ALL MEN BY THESE PRESENTS:** That the GREAT AMERICAN INSURANCE COMPANY, a corporation organized and existing under and by virtue of the laws of the State of Ohio, does hereby nominate, constitute and appoint the person or persons named below its true and lawful attorney-in-fact, for it and in its name, place and stead to execute on behalf of the said Company, as surety, the specific bond, undertaking or contract of suretyship referenced herein; provided that the liability of the said Company on any such bond, undertaking or contract of suretyship executed under this authority shall not exceed the limit stated below. The bond number on this Power of Attorney must match the bond number on the bond to which it is attached or it is invalid.

| Name            | Address                     | Limit of Power   |
|-----------------|-----------------------------|------------------|
| Florieta Acosta | Greenwood Village, Colorado | \$100,000,000.00 |

IN WITNESS WHEREOF the GREAT AMERICAN INSURANCE COMPANY has caused these presents to be signed and attested by its appropriate officers and its corporate seal hereunto affixed this 3rd day of November, 2017  
GREAT AMERICAN INSURANCE COMPANY  
Attest



*Stephen C. Beraha*  
Assistant Secretary

*David C. Kitchin*  
Divisional Senior Vice President

DAVID C. KITCHIN (877-377-2405)

STATE OF OHIO, COUNTY OF HAMILTON - ss:  
On this 3rd day of November, 2017, before me personally appeared DAVID C. KITCHIN, to me known, being duly sworn, deposes and says that he resides in Cincinnati, Ohio, that he is a Divisional Senior Vice President of the Bond Division of Great American Insurance Company, the Company described in and which executed the above instrument; that he knows the seal of the said Company; that the seal affixed to the said instrument is such corporate seal; that it was so affixed by authority of his office under the By-Laws of said Company, and that he signed his name thereto by like authority.



**Susan A. Kohorst**  
Notary Public, State of Ohio  
My Commission Expires 05-18-2020

*Susan A. Kohorst*

This Power of Attorney is granted by authority of the following resolutions adopted by the Board of Directors of Great American Insurance Company by unanimous written consent dated June 9, 2008.

*RESOLVED: That the Divisional President, the several Divisional Senior Vice Presidents, Divisional Vice Presidents and Divisional Assistant Vice Presidents, or any one of them, be and hereby is authorized, from time to time, to appoint one or more Attorneys-in-Fact to execute on behalf of the Company, as surety, any and all bonds, undertakings and contracts of suretyship, or other written obligations in the nature thereof; to prescribe their respective duties and the respective limits of their authority; and to revoke any such appointment at any time.*

*RESOLVED FURTHER: That the Company seal and the signature of any of the aforesaid officers and any Secretary or Assistant Secretary of the Company may be affixed by facsimile to any power of attorney or certificate of either given for the execution of any bond, undertaking, contract of suretyship, or other written obligation in the nature thereof, such signature and seal when so used being hereby adopted by the Company as the original signature of such officer and the original seal of the Company, to be valid and binding upon the Company with the same force and effect as though manually affixed.*

**CERTIFICATION**

I, STEPHEN C. BERAHA, Assistant Secretary of Great American Insurance Company, do hereby certify that the foregoing Power of Attorney and the Resolutions of the Board of Directors of June 9, 2008 have not been revoked and are now in full force and effect.

Signed and sealed this 3rd day of November, 2017



*Stephen C. Beraha*  
Assistant Secretary



November 1, 2017

Ms. Jenna Westbrook  
Hamon Contractors, Inc.  
5670 Franklin Street  
Denver, CO 80216

Dear Ms. Westbrook:

The Contractor's Prequalification Board has reviewed the application submitted by your firm. The Board has recommended that your firm be granted Project Specific Permission to bid the upcoming **Pond 001 Expansion Project at Denver International Airport, Contract #201737313**. The Executive Director of the Department of Aviation and I have reviewed the recommendation and approve your prequalification.

Compliance with the "Rules For Prequalification of Construction Contractors" with the Departments of Aviation and Public Works of the City and County of Denver is necessary in order to ensure acceptable bids. Should you wish to bid on any other project in which the cost of construction is estimated to exceed your bid limit, or if you intend to participate in excess of \$1,000,000 in a joint venture, you must submit a written request for further consideration by the Prequalification Board.

We appreciate your interest in bidding on City and County of Denver contracts and look forward to working with you in the future.

Should you have any questions concerning the prequalification process, do not hesitate to contact us at 720.865.2539.

Sincerely,

George Delaney  
Interim Executive Director of Public Works

cc: Prequalification Board File

# **CONTRACT**

**The contract is contained in the pages immediately following this page  
which include the following attachments:**

**These pages are not included in the page numbering of this contract document.**

## C O N T R A C T

**THIS CONTRACT** is made and entered into as of the date indicated on the City signature page below, by and between the **CITY AND COUNTY OF DENVER**, a municipal corporation of the State of Colorado, on behalf of its Department of Aviation ("**City**" or "**Party of the First Part**"), and **HAMON INFRASTRUCTURE, INC.**, a corporation organized and existing under and by virtue of the laws of the State of Colorado ("**Contract**" or "**Party of the Second Part**").

## W I T N E S S E T H

**WHEREAS**, the City, for at least three (3) consecutive days, advertised that sealed bids would be received for furnishing all labor, tools, supplies, equipment, materials and everything necessary and required for work required by Contract No. 201737313, to be performed at Denver International Airport ("**DEN**"); and

**WHEREAS**, bids to said advertisement have been received by the Chief Executive Officer of DEN ("**CEO**"), who has recommended that a contract for the work be made and entered into with the Contractor, which was the lowest, responsive, qualified bidder; and

**WHEREAS**, said Contractor is now willing and able to perform all of said work in accordance with its bid and the "**Contract Documents**" described below;

**NOW, THEREFORE**, for and in consideration of the compensation to be paid the Contractor, the mutual agreements hereinafter contained, and subject to the terms hereinafter stated, it is mutually agreed as follows:

**ARTICLE I - CONTRACT DOCUMENTS**: It is agreed by the parties that the instruments, drawings, and documents described below and attached to and bound with this Contract (the "**Contract Documents**") are incorporated into the Contract by this reference, and are as fully a part of this Contract as if they were set out here verbatim and in full:

- Advertisement of Notice of Invitation for Bids
- Instructions to Bidders
- Addenda (if any)
- Bid Forms
  - Bid letter
  - Schedule of Prices and Quantities
  - Bid Data Forms
  - Commitment to Minority/Women Business Enterprise Participation
- Notice to Apparent Low Bidder
- Contract
- Performance Bond
- Payment Bond
- Notice to Proceed
- Form of Final Receipt
- Construction Contract General Conditions

Special Conditions  
Prevailing wage schedules  
Insurance certificate(s)  
Equal Employment Opportunity Provisions  
Technical Specifications  
Contract Drawings  
Approved Shop Drawings  
Change Directives  
Change Orders

**ARTICLE II - SCOPE OF WORK:** The Contractor agrees to and shall furnish all labor and tools, supplies, equipment, superintendence, materials, and everything necessary for and required to do, perform, and complete all of the work described, drawn, set forth, shown, and included in the Contract Documents.

**ARTICLE III - TERMS OF PERFORMANCE:** The Contractor agrees to begin the performance of the work required under this Contract within ten (10) days after being notified to commence work by the Senior Vice President – Airport Infrastructure Management and agrees to fully complete the Work in its entirety within one hundred forty-one (141) consecutive calendar days from the date of said Notice to Proceed. This period of performance is also referred to as Contract Time. The Contractor is not authorized to commence work prior to its receipt of the Notice to Proceed.

**ARTICLE IV - LIQUIDATED DAMAGES:** It is understood and agreed by and between the City and the Contractor that, if the Contractor fails to achieve Substantial Completion of the Work within the Contract Time or fails to substantially complete the Work described in a Milestone Area within the time set forth in the Special Conditions, the City will suffer substantial damages, which damages would be difficult to accurately determine. The parties hereto have considered the possible elements of damages and have agreed that the amount of liquidated damages for the Contractor's failure to substantially complete the work within the Contract Time or to substantially complete the work described in Milestone Areas within the time set forth in the Special Conditions shall be those amounts listed in the Special Conditions. If the Contractor shall fail to pay such liquidated damages promptly upon demand therefor, the Surety on its Performance Bond and Payment Bond shall pay such damages. Also, the City may withhold all, or any part of, such liquidated damages from any payment due the Contractor. Additional provisions relating to liquidated damages are set forth in the Construction Contract General Conditions and Special Conditions.

**ARTICLE V - TERMS OF PAYMENT:** The City agrees to pay the Contractor for the performance and completion of all of the Work as required by the Contract Documents, and the Contractor agrees to accept as its full and only compensation therefor, a total amount of FIVE MILLION, SEVENTY THOUSAND AND 00/100 Dollars (\$5,070,000.00) (the “**Maximum Contract Amount**”). In no event will the City’s liability exceed the Maximum Contract Amount, as adjusted by duly authorized Change Orders in accordance with this Contract. The parties specifically agree that any performance by the Contractor hereunder shall not subject the City to any cost, charge, or fee not specified above.

Payments will be made to the Contractor in accordance with the City's Prompt Payment Ordinance, D.R.M.C. Sections 20-107, *et. seq.*, subject to the Maximum Contract Amount. Contractor agrees that interest and late fees shall be payable by the City only to the extent authorized and provided for in the City's Prompt Payment Ordinance.

Payment will be in accordance with the provisions of the Contract Documents, including Title 9 of the General Conditions, and will be made solely and exclusively from funds appropriated and otherwise lawfully made available for the purposes of this Contract from the City and County of Denver Airport System, Operations and Maintenance and Capital Improvement Funds. The City has no obligation to make payments from any other fund or source or to make additional appropriations or allocations to such fund to satisfy such costs or other obligations.

**ARTICLE VI - DISPUTES:** It is agreed and understood by the parties that disputes regarding this Contract shall be resolved by administrative hearing under procedures described in Denver Revised Municipal Code Section 5-17.

**ARTICLE VII - CONTRACT BINDING:** It is agreed that this Contract shall be binding on and inure to the benefit of the parties hereto, their heirs, executors, administrators, assigns, and successors.

**ARTICLE VIII - SEVERABILITY:** If any part, portion, or provision of this Contract shall be found or declared null, void, or unenforceable for any reason whatsoever by any court of competent jurisdiction or any governmental agency having authority thereover, only such part, portion, or provision shall be affected thereby and all other parts, portions, and provisions of this Contract shall remain in full force and effect.

**ARTICLE IX - ASSIGNMENT:** The Contractor shall not assign the whole or any part of its duties, rights, and interests in this Contract without first obtaining the written consent of the CEO.

**ARTICLE X - APPROVALS:** In the event this Contract calls for the payment by the City of Five Million Dollars (\$5,000,000.00) or more, approval by the Denver City Council, acting by Ordinance in accordance with Section 3.2.6 of the Charter of the City and County of Denver, is and shall be an express condition precedent to the lawful and binding execution and performance of this Contract.

**ARTICLE XI - JOINT VENTURE:** If the Contractor is a Joint Venture, the partners to the Joint Venture shall be jointly and severally liable to the City for the performance of all duties and obligations of the Contractor which are set forth in the Contract.

**ARTICLE XII - NO DISCRIMINATION IN EMPLOYMENT:** In connection with the performance of work under this Contract, the Contractor agrees not to refuse to hire, discharge, promote or demote, or to discriminate in matters of compensation against any person otherwise qualified, solely because of race, color, religion, national origin, gender, age, military status, sexual orientation, gender variance, marital status, or physical or mental disability; and the Contractor further agrees to insert the foregoing provision in all subcontracts hereunder.

**ARTICLE XIII - WAIVER OF CRS 13-20-801, et seq.:** Notwithstanding any other provision of this Contract, the Contractor specifically waives all of the provisions of Colorado Revised Statutes §§ 13-20-801 *et seq.* as they may relate to the Contractor's performance under this Contract.

**ARTICLE XIV - COORDINATION OF SERVICES:** The Contractor agrees to perform its work under this Contract in accordance with the operational requirements of DEN, and all work and movement of personnel or equipment on areas included within the DEN site shall be subject to the regulations and restrictions established by the City or its authorized agents.

**ARTICLE XV - COMPLIANCE WITH ALL LAWS AND REGULATIONS:** All of the work performed under this Contract by the Consultant shall comply with all applicable laws, rules, regulations and codes of the United States and the State of Colorado, and with the charter, ordinances and rules and regulations of the City and County of Denver.

**ARTICLE XVI – PROMPT PAY:** The Contractor is subject to D.R.M.C. Section 20-112 wherein the Contractor is to pay its subcontractors in a timely fashion. A payment is timely if it is mailed to the subcontractor no later than seven days after receipt of any payment from City. Any late payments are subject to a late payment penalty as provided for in the prompt pay ordinance (D.R.M.C. Sections 20-107 through 20-118).

**ARTICLE XVII – COLORADO OPEN RECORDS ACT:** The Contractor acknowledges that the City is subject to the provisions of the Colorado Open Records Act, Colorado Revised Statutes §24-72-201 *et seq.*, and the Contractor agrees that it will fully cooperate with the City in the event of a request or lawsuit arising under such act for the disclosure of any materials or information which the Contractor asserts is confidential and exempt from disclosure. Any other provision of this Contract notwithstanding, including the Contract Documents, exhibits, attachments, and other documents incorporated into this Contract by reference, and all materials, records, and information provided by the Contractor to the City shall be considered confidential by the City **only** to the extent provided in the Colorado Open Records Act, and the Contractor agrees that any disclosure of information by the City consistent with the provisions of the Colorado Open Records Act shall result in no liability of the City.

**ARTICLE XVIII – ELECTRONIC SIGNATURES AND ELECTRONIC RECORDS:** Contractor consents to the use of electronic signatures by the City. The Contract and any other documents requiring a signature hereunder may be signed electronically by the City in the manner specified by the City. The Parties agree not to deny the legal effect or enforceability of the Contract solely because it is in electronic form or because an electronic record was used in its formation. The Parties agree not to object to the admissibility of the Contract in the form of an electronic record, or a paper copy of an electronic document, or a paper copy of a document bearing an electronic signature, on the ground that it is an electronic record or electronic signature or that it is not in its original form or is not an original.

[END OF DOCUMENT; SIGNATURE PAGES FOLLOW]

Contract Control Number: PLANE-201737313-00

Contractor Name: HAMON INFRASTRUCTURE, INC.

By: 

Name: BRUCE W. HAMON  
(please print)

Title: PRESIDENT  
(please print)

ATTEST: [if required]

By: 

Name: MICHAEL D. WALTERS  
(please print)

Title: SEC/TREAS  
(please print)





**Contract Control Number:**

IN WITNESS WHEREOF, the parties have set their hands and affixed their seals at Denver, Colorado as of

SEAL

**CITY AND COUNTY OF DENVER**

ATTEST:

By \_\_\_\_\_

\_\_\_\_\_

APPROVED AS TO FORM:

REGISTERED AND COUNTERSIGNED:

By \_\_\_\_\_

By \_\_\_\_\_

By \_\_\_\_\_



**PERFORMANCE BOND**

**KNOW ALL MEN BY THESE PRESENTS**, that we, the undersigned **HAMON INFRASTRUCTURE, INC.**, a corporation organized under the laws of the State of **COLORADO**, hereinafter referred to as the "Contractor" and **GREAT AMERICAN INSURANCE COMPANY**, a corporation organized under the laws of the State of **OHIO**, and authorized to transact business in the State of Colorado, hereinafter referred to as Surety, are held and firmly bound unto the **CITY AND COUNTY OF DENVER**, a municipal corporation of the State of Colorado, hereinafter referred to as the "CITY", in the penal sum of **FIVE MILLION, SEVENTY THOUSAND AND 00/100 Dollars (\$5,070,000.00)**, lawful money of the United States of America, for the payment of which sum the Contractor and Surety bind themselves and their heirs, executors, administrators, successors and assigns, jointly and severally by these presents.

**WHEREAS**, the above Contractor has, as of the date of execution listed on the contract signature page, entered into a written contract with the City for furnishing all labor, materials, equipment, tools, superintendence, and other facilities and accessories for the construction of 201737313, Pond 001 Expansion, Denver International Airport, in accordance with the Technical Specifications, Contract Drawings and all other Contract Documents therefor which are incorporated herein by reference and made a part hereof, and are herein referred to as the Contract.

**NOW, THEREFORE**, the condition of this performance bond is such that if the Contractor:

1. Promptly and faithfully observes, abides by and performs each and every covenant, condition and part of said Contract, including, but not limited to, its warranty provisions, in the time and manner prescribed in the Contract, and
2. Pays the City all losses, damages (liquidated or actual, including, but not limited to, damages caused by delays in the performance of the Contract), expenses, costs and attorneys' fees, that the City sustains resulting from any breach or default by the Contractor under the Contract, then this bond is void; otherwise, it shall remain in full force and effect.

**IN ADDITION**, if said Contractor fails to duly pay for any labor, materials, team hire, sustenance, provisions, provender, or any other supplies used or consumed by said Contractor or its subcontractors in its performance of the work contracted to be done or fails to pay any person who supplies rental machinery, tools, or equipment, all amounts due as the result of the use of such machinery, tools, or equipment in the prosecution of the work, the Surety shall pay the same in an amount not exceeding the amount of this obligation, together with interest as provided by law.

**PROVIDED FURTHER**, that the said Surety, for value received, hereby stipulates and agrees that any and all changes in the Contract or compliance or noncompliance with the formalities in the Contract for making such changes shall not affect the Surety's obligations under this bond and the Surety hereby waives notice of any such changes.

(End of Page)

IN WITNESS WHEREOF, said Contractor and said Surety have executed these presents as of this \_\_\_\_ day of \_\_\_\_\_, \_\_\_\_\_.

Hamon Infrastructure, Inc.  
CONTRACTOR

By:   
President

Great American Insurance Company  
SURETY

By:   
Attorney-in-Fact - Florietta Acosta

(Accompany this bond with Attorney-in-Fact's authority from the Surety to execute bond, certified to include the date of the bond.)

CITY AND COUNTY OF DENVER

By:   
MAYOR

By:   
Chief Executive Officer  
Denver International Airport

APPROVED AS TO FORM:

KRISTIN M. BRONSON, Attorney for the  
City and County of Denver

By:   
Assistant City Attorney

**GREAT AMERICAN INSURANCE COMPANY®**

Administrative Office: 301 E 4TH STREET • CINCINNATI, OHIO 45202 • 513-369-5000 • FAX 513-723-2740

The number of persons authorized by this power of attorney is not more than ONE

Bond No. 2061927

**POWER OF ATTORNEY**

KNOW ALL MEN BY THESE PRESENTS: That the GREAT AMERICAN INSURANCE COMPANY, a corporation organized and existing under and by virtue of the laws of the State of Ohio, does hereby nominate, constitute and appoint the person or persons named below its true and lawful attorney-in-fact, for it and in its name, place and stead to execute on behalf of the said Company, as surety, the specific bond, undertaking or contract of suretyship referenced herein; provided that the liability of the said Company on any such bond, undertaking or contract of suretyship executed under this authority shall not exceed the limit stated below. The bond number on this Power of Attorney must match the bond number on the bond to which it is attached or it is invalid.

| Name            | Address                     | Limit of Power   |
|-----------------|-----------------------------|------------------|
| Florieta Acosta | Greenwood Village, Colorado | \$100,000,000.00 |

IN WITNESS WHEREOF the GREAT AMERICAN INSURANCE COMPANY has caused these presents to be signed and attested by its appropriate officers and its corporate seal hereunto affixed this 6th day of December, 2017  
Attest  
GREAT AMERICAN INSURANCE COMPANY



*Steph L. C. B.*

Assistant Secretary

*David C. Kitchin*

Divisional Senior Vice President

DAVID C. KITCHIN (877-377-2405)

STATE OF OHIO, COUNTY OF HAMILTON - ss:

On this 6th day of December, 2017, before me personally appeared DAVID C. KITCHIN, to me known, being duly sworn, deposes and says that he resides in Cincinnati, Ohio, that he is a Divisional Senior Vice President of the Bond Division of Great American Insurance Company, the Company described in and which executed the above instrument; that he knows the seal of the said Company; that the seal affixed to the said instrument is such corporate seal; that it was so affixed by authority of his office under the By-Laws of said Company, and that he signed his name thereto by like authority.



**Susan A. Kohorst**  
Notary Public, State of Ohio  
My Commission Expires 05-18-2020

*Susan A. Kohorst*

This Power of Attorney is granted by authority of the following resolutions adopted by the Board of Directors of Great American Insurance Company by unanimous written consent dated June 9, 2008.

RESOLVED: That the Divisional President, the several Divisional Senior Vice Presidents, Divisional Vice Presidents and Divisional Assistant Vice Presidents, or any one of them, be and hereby is authorized, from time to time, to appoint one or more Attorneys-in-Fact to execute on behalf of the Company, as surety, any and all bonds, undertakings and contracts of suretyship, or other written obligations in the nature thereof; to prescribe their respective duties and the respective limits of their authority; and to revoke any such appointment at any time.

RESOLVED FURTHER: That the Company seal and the signature of any of the aforesaid officers and any Secretary or Assistant Secretary of the Company may be affixed by facsimile to any power of attorney or certificate of either given for the execution of any bond, undertaking, contract of suretyship, or other written obligation in the nature thereof, such signature and seal when so used being hereby adopted by the Company as the original signature of such officer and the original seal of the Company, to be valid and binding upon the Company with the same force and effect as though manually affixed.

**CERTIFICATION**

I, STEPHEN C. BERAHA, Assistant Secretary of Great American Insurance Company, do hereby certify that the foregoing Power of Attorney and the Resolutions of the Board of Directors of June 9, 2008 have not been revoked and are now in full force and effect.

Signed and sealed this \_\_\_\_\_ day of \_\_\_\_\_, 2017



*Steph L. C. B.*

Assistant Secretary

**PAYMENT BOND**

**KNOW ALL MEN BY THESE PRESENTS**, that we, the undersigned **HAMON INFRASTRUCTURE, INC.**, a corporation organized under the laws of the State of **COLORADO**, hereinafter referred to as the "Contractor" and **GREAT AMERICAN INSURANCE COMPANY**, a corporation organized under the laws of the State of **OHIO**, and authorized to transact business in the State of Colorado, hereinafter referred to as Surety, are held and firmly bound unto the **CITY AND COUNTY OF DENVER**, a municipal corporation of the State of Colorado, hereinafter referred to as the "CITY", in the penal sum of **FIVE MILLION, SEVENTY THOUSAND AND 00/100 Dollars (\$5,070,000.00)**, lawful money of the United States of America, for the payment of which sum the Contractor and Surety bind themselves and their heirs, executors, administrators, successors and assigns, jointly and severally by these presents.

**WHEREAS**, the above Contractor has entered into a written contract with the City for furnishing all labor, materials, tools, superintendence, and other facilities and accessories for the construction of Contract No. 201737313, Pond 001 Expansion, Denver International Airport, in accordance with the Technical Specifications, Contract Drawings and all other Contract Documents therefor which are incorporated herein by reference and made a part hereof, and are herein referred to as the Contract.

**NOW, THEREFORE**, the condition of this payment bond obligation is such that if the Contractor shall at all times promptly make payments of all amounts lawfully due to all persons supplying or furnishing it or its subcontractors with labor and materials, rental machinery, tools, or equipment, used or performed in the prosecution of work provided for in the above Contract and shall indemnify and save harmless the City to the extent of any and all payments in connection with the carrying out of such Contract which the City may be required to make under the law, then this obligation shall be null and void, otherwise, it shall remain in full force and effect;

**PROVIDED FURTHER**, that the said Surety, for value received, hereby stipulates and agrees that any and all changes in the Contract, or compliance or noncompliance with the formalities in the Contract for making such changes shall not affect the Surety's obligations under this bond and the Surety hereby waives notice of any such changes.

[END OF PAGE]

IN WITNESS WHEREOF, said Contractor and said Surety have executed these presents as of this \_\_\_\_ day of \_\_\_\_\_, \_\_\_\_\_.

Hamon Infrastructure, Inc.  
CONTRACTOR

By:   
President

Great American Insurance Company  
SURETY

By:   
Attorney-in-Fact - Florietta Acosta

(Accompany this bond with Attorney-in-Fact's authority from the Surety to execute bond, certified to include the date of the bond.)

CITY AND COUNTY OF DENVER

By:   
MAYOR

By:   
Manager of Aviation

APPROVED AS TO FORM:

KRISTIN M. BRONSON, Attorney for the  
City and County of Denver

By:   
Assistant City Attorney

**GREAT AMERICAN INSURANCE COMPANY®**

Administrative Office: 301 E 4TH STREET • CINCINNATI, OHIO 45202 • 513-369-5000 • FAX 513-723-2740

The number of persons authorized by this power of attorney is not more than ONE

Bond No. 2061927

**POWER OF ATTORNEY**

**KNOW ALL MEN BY THESE PRESENTS:** That the GREAT AMERICAN INSURANCE COMPANY, a corporation organized and existing under and by virtue of the laws of the State of Ohio, does hereby nominate, constitute and appoint the person or persons named below its true and lawful attorney-in-fact, for it and in its name, place and stead to execute on behalf of the said Company, as surety, the specific bond, undertaking or contract of suretyship referenced herein; provided that the liability of the said Company on any such bond, undertaking or contract of suretyship executed under this authority shall not exceed the limit stated below. The bond number on this Power of Attorney must match the bond number on the bond to which it is attached or it is invalid.

| Name            | Address                     | Limit of Power   |
|-----------------|-----------------------------|------------------|
| Florieta Acosta | Greenwood Village, Colorado | \$100,000,000.00 |

IN WITNESS WHEREOF the GREAT AMERICAN INSURANCE COMPANY has caused these presents to be signed and attested by its appropriate officers and its corporate seal hereunto affixed this 6th day of December, 2017  
Attest  
GREAT AMERICAN INSURANCE COMPANY



*My L C. B.*

Assistant Secretary

*David C. Kitchin*

Divisional Senior Vice President

DAVID C. KITCHIN (877-377-2405)

STATE OF OHIO, COUNTY OF HAMILTON - ss:

On this 6th day of December, 2017, before me personally appeared DAVID C. KITCHIN, to me known, being duly sworn, deposes and says that he resides in Cincinnati, Ohio, that he is a Divisional Senior Vice President of the Bond Division of Great American Insurance Company, the Company described in and which executed the above instrument; that he knows the seal of the said Company; that the seal affixed to the said instrument is such corporate seal; that it was so affixed by authority of his office under the By-Laws of said Company, and that he signed his name thereto by like authority.



**Susan A. Kohorst**  
Notary Public, State of Ohio  
My Commission Expires 05-18-2020

*Susan A Kohorst*

This Power of Attorney is granted by authority of the following resolutions adopted by the Board of Directors of Great American Insurance Company by unanimous written consent dated June 9, 2008.

*RESOLVED: That the Divisional President, the several Divisional Senior Vice Presidents, Divisional Vice Presidents and Divisional Assistant Vice Presidents, or any one of them, be and hereby is authorized, from time to time, to appoint one or more Attorneys-in-Fact to execute on behalf of the Company, as surety, any and all bonds, undertakings and contracts of suretyship, or other written obligations in the nature thereof; to prescribe their respective duties and the respective limits of their authority; and to revoke any such appointment at any time.*

*RESOLVED FURTHER: That the Company seal and the signature of any of the aforesaid officers and any Secretary or Assistant Secretary of the Company may be affixed by facsimile to any power of attorney or certificate of either given for the execution of any bond, undertaking, contract of suretyship, or other written obligation in the nature thereof, such signature and seal when so used being hereby adopted by the Company as the original signature of such officer and the original seal of the Company, to be valid and binding upon the Company with the same force and effect as though manually affixed.*

**CERTIFICATION**

I, STEPHEN C. BERAHA, Assistant Secretary of Great American Insurance Company, do hereby certify that the foregoing Power of Attorney and the Resolutions of the Board of Directors of June 9, 2008 have not been revoked and are now in full force and effect.

Signed and sealed this \_\_\_\_\_ day of \_\_\_\_\_



*My L C. B.*

Assistant Secretary

**CITY AND COUNTY OF DENVER**

**DEPARTMENT OF AVIATION**

\*\*\*\*\*

**NOTICE TO PROCEED**

Date:

TO: [Bidder name and address]

You are hereby authorized and directed to proceed on this date with the work of constructing Contract No. 201737313, Pond 001 Expansion, Denver International Airport, Denver, Colorado, as set forth in detail in the Contract Documents for the City and County of Denver.

The bid security submitted with your bid is herewith returned to you.

CITY AND COUNTY OF DENVER

By \_\_\_\_\_  
Senior Vice President  
Airport Infrastructure Management

By \_\_\_\_\_  
Chief Executive Officer  
Denver International Airport



**City and County of Denver**



**DENVER**  
THE MILE HIGH CITY

DEPARTMENT OF AVIATION  
DEPARTMENT OF PUBLIC WORKS

**STANDARD SPECIFICATIONS FOR  
CONSTRUCTION  
GENERAL CONTRACT CONDITIONS**

2011 Edition

**Statement**

The City and County of Denver does not warrant or represent the accuracy or timeliness of the information contained in this page or any of its constituent pages and the information presented is for instructional purposes and illustration only and is not intended to be specific advice, legal or otherwise. The City has made every effort to provide accurate up-to-date information, however this database is dynamic and errors can occur. The City and County of Denver shall not be held responsible for errors or omissions nor be liable for any special consequential or exemplary damages resulting, in whole or in part, from any viewer(s)' uses of, or in reliance upon, this material.

|  |          |
|--|----------|
| <b>TITLE 1 - DEFINITIONS.....</b>  | <b>1</b> |
| 101 CITY .....   | 1        |
| 102 CONTRACT .....   | 1        |
| 103 CONTRACT AMOUNT .....  | 1        |
| 104 CONTRACT DOCUMENTS .....   | 1        |
| 105 CONTRACT TIME .....  | 1        |
| 106 CONTRACTOR .....   | 2        |
| 107 CONTRACTOR PERSONNEL .....   | 2        |
| 108 DAYS.....  | 2        |
| 109 DEPUTY MANAGER.....  | 2        |
| 110 DESIGNER.....  | 2        |
| 111 FINAL COMPLETION .....   | 2        |
| 112 MANAGER .....  | 3        |
| 113 PRODUCT DATA.....  | 3        |
| 114 PROJECT.....   | 3        |
| 115 PROJECT MANAGER .....  | 3        |
| 116 SAMPLES.....   | 3        |
| 117 SHOP DRAWINGS.....   | 3        |
| 118 SUBCONTRACTOR.....   | 3        |
| 119 SUBSTANTIAL COMPLETION .....   | 3        |
| 120 SUPPLIER .....   | 4        |
| 121 WORK .....   | 4        |
| <b>TITLE 2 – CITY ADMINISTRATIVE ORGANIZATIONS; LINE OF AUTHORITY.....</b> | <b>5</b> |
| 201 DEPARTMENT OF AVIATION .....   | 5        |
| 202 MANAGER OF AVIATION.....   | 5        |
| 203 DEPARTMENT OF PUBLIC WORKS .....                                       | 5        |
| 204 MANAGER OF PUBLIC WORKS.....   | 5        |
| 205 BUILDING INSPECTION.....   | 5        |
| 206 ZONING .....   | 5        |
| 207 DIVISION OF SMALL BUSINESS OPPORTUNITY .....                           | 6        |
| 208 CITY AUDITOR .....   | 6        |
| 209 MANAGER OF FINANCE.....  | 6        |
| 210 CITY ATTORNEY.....   | 6        |
| 211 OFFICE OF RISK MANAGEMENT.....   | 6        |
| 212 CITY'S CONTRACT ADMINISTRATION LINE OF AUTHORITY .....                 | 6        |
| 213 CITY'S COMMUNICATIONS WITH THE CONTRACTOR .....                        | 7        |
| <b>TITLE 3 - CONTRACTOR PERFORMANCE AND SERVICES.....</b>                  | <b>8</b> |
| 301 CONSIDERATION (CONTRACTOR'S PROMISE OF PERFORMANCE).....               | 8        |
| 302 NOTICE TO PROCEED AND COMPLETION OF THE WORK.....                      | 8        |
| 303 EXACT CONTRACTOR PERFORMANCE .....                                     | 8        |
| 304 SUBSTITUTED PERFORMANCE .....  | 8        |
| 305 WORK PERFORMED UNDER ADVERSE WEATHER CONDITIONS .....                  | 9        |
| 306 WORKING HOURS AND SCHEDULE .....                                       | 9        |
| 307 CONTRACTOR'S SUPERINTENDENT.....                                       | 10       |
| 308 COMMUNICATIONS .....   | 10       |

|   |  |           |
|---|--|-----------|
| 309   | CONTRACTOR SUBMITTALS AND OTHER WRITTEN COMMUNICATIONS TO THE CITY .....         | 10        |
| 310   | COMPETENCE OF CONTRACTOR’S WORK FORCE .....                                      | 11        |
| 311   | NO EMPLOYMENT OF ILLEGAL ALIENS TO PERFORM WORK UNDER THE CONTRACT .....         | 11        |
| 312   | CONDUCT OF CONTRACTOR'S PERSONNEL .....  | 12        |
| 313   | SUGGESTIONS TO CONTRACTOR.....   | 12        |
| 314   | WORK FORCE .....   | 12        |
| 315   | CONSTRUCTION MACHINES AND STANBY EQUIPMENT .....                                 | 13        |
| 316   | CUTTING AND PATCHING THE WORK .....  | 13        |
| 317   | PERMITS AND LICENSES .....   | 13        |
| 318   | CONSTRUCTION SURVEYS .....   | 14        |
| 319   | PRESERVATION OF PERMANENT LAND SURVEY CONTROL MARKERS .....                      | 14        |
| 320   | TRADEMARKS, COPYRIGHTS AND PATENTED DEVICES, MATERIALS, AND PROCESSES .....      | 15        |
| 321   | PROJECT SIGNS .....  | 15        |
| 322   | PUBLICITY AND ADVERTISING .....  | 16        |
| 323   | TAXES.....   | 16        |
| 324   | DOCUMENTS AND SAMPLES AT THE SITE .....  | 17        |
| 325   | CLEANUP DURING CONSTRUCTION.....   | 17        |
| 326   | SANITARY FACILITIES .....  | 18        |
| 327   | POWER, LIGHTING, HEATING, VENTILATING, AIR CONDITIONING AND WATER SERVICES ..... | 18        |
| <b>TITLE 4 - CONTRACT DOCUMENTS (DRAWINGS AND SPECIFICATIONS) .....</b> |  | <b>19</b> |
| 401   | CONTRACT DOCUMENTS - REVIEW AND INTERPRETATION.....                              | 19        |
| 402   | OWNERSHIP OF CONTRACT DRAWINGS AND TECHNICAL SPECIFICATIONS.....                 | 20        |
| 403   | CONTRACT DRAWINGS AND TECHNICAL SPECIFICATIONS ISSUED TO THE CONTRACTOR .....    | 20        |
| 404   | REQUESTS FOR INFORMATION OR CLARIFICATION .....                                  | 21        |
| 405   | SHOP DRAWINGS, PRODUCT DATA AND SAMPLES .....                                    | 21        |
| 406   | SUBSTITUTION OF MATERIALS AND EQUIPMENT .....                                    | 22        |
| <b>TITLE 5 - SUBCONTRACTS .....</b>                                     |  | <b>24</b> |
| 501   | SUBCONTRACTS .....   | 24        |
| 502   | SUBCONTRACTOR ACCEPTANCE .....   | 24        |
| <b>TITLE 6 - TIME OF COMMENCEMENT AND COMPLETION .....</b>              |  | <b>27</b> |
| 601   | BEGINNING, PROGRESS AND TIME OF COMPLETION.....                                  | 27        |
| 602   | LIQUIDATED DAMAGES, ADMINISTRATIVE COSTS; ACTUAL DAMAGES.....                    | 27        |
| 603   | DELAY DAMAGES .....  | 28        |
| <b>TITLE 7 - COOPERATION, COORDINATION AND RATE OF PROGRESS.....</b>    |  | <b>29</b> |
| 701   | COOPERATION WITH OTHER WORK FORCES .....   | 29        |
| 702   | COORDINATION OF THE WORK.....  | 30        |

|  |  |           |
|--|--|-----------|
| 703  | COORDINATION OF PUBLIC CONTACT.....                                | 30        |
| 704  | RATE OF PROGRESS.....  | 30        |
| <b>TITLE 8 - PROTECTION OF PERSONS AND PROPERTY .....</b>                        |  | <b>32</b> |
| 801  | SAFETY OF PERSONS.....   | 32        |
| 802  | PROTECTIVE DEVICES AND SAFETY PRECAUTIONS.....                     | 33        |
| 803  | PROTECTION OF PROPERTY AND WORK IN PROGRESS.....                   | 33        |
| 804  | PROTECTION OF MUNICIPAL, PUBLIC SERVICE OR UTILITY<br>SYSTEMS..... | 34        |
| 805  | PROTECTION OF STREET AND ROAD SYSTEM.....                          | 35        |
| 806  | PROTECTION OF DRAINAGE WAYS.....                                   | 36        |
| 807  | PROTECTION OF THE ENVIRONMENT .....                                | 36        |
| 808  | HAZARDOUS AND EXPLOSIVE MATERIALS OR SUBSTANCES .....              | 37        |
| 809  | ARCHEOLOGICAL AND HISTORICAL DISCOVERIES .....                     | 37        |
| <b>TITLE 9 - COMPENSATION.....</b>   |  | <b>38</b> |
| 901  | CONSIDERATION (CITY'S PROMISE TO PAY) .....                        | 38        |
| 902  | PAYMENT PROCEDURE .....  | 38        |
| 903  | SCHEDULE OF VALUES IN LUMP SUM CONTRACTS.....                      | 39        |
| 904  | UNIT PRICE CONTRACTS.....  | 39        |
| 905  | PROGRESS PERIOD.....   | 39        |
| 906  | APPLICATIONS FOR PAYMENT .....                                     | 40        |
| 907  | RELEASES AND CONTRACTORS CERTIFICATION OF PAYMENT .....            | 41        |
| 908  | RETAINAGE.....   | 41        |
| 909  | ADDITIONAL WITHHOLDING OF PROGRESS PAYMENTS .....                  | 42        |
| 910  | FINAL ESTIMATE AND PAYMENT .....                                   | 43        |
| 911  | ACCOUNTING OF COSTS AND AUDIT .....                                | 43        |
| <b>TITLE 10 - WAGES .....</b>  |  | <b>45</b> |
| 1001   | PREVAILING WAGE ORDINANCE.....                                     | 45        |
| 1002   | POSTING OF THE APPLICABLE WAGE RATES.....                          | 45        |
| 1003   | RATE AND FREQUENCY OF WAGES PAID.....                              | 45        |
| 1004   | REPORTING WAGES PAID.....  | 45        |
| 1005   | FAILURE TO PAY PREVAILING WAGES .....                              | 46        |
| <b>TITLE 11 - CHANGES IN THE WORK, CONTRACT PRICE OR CONTRACT<br/>TIME .....</b> |  | <b>47</b> |
| 1101   | CHANGE ORDER .....   | 47        |
| 1102   | CITY INITIATED CHANGES .....                                       | 47        |
| 1103   | CONTRACTOR CHANGE REQUEST.....                                     | 48        |
| 1104   | ADJUSTMENT TO CONTRACT AMOUNT.....                                 | 51        |
| 1105   | TIME EXTENSIONS .....  | 54        |
| <b>TITLE 12 - CONTRACTOR CLAIMS FOR ADJUSTMENT AND DISPUTES .....</b>            |  | <b>56</b> |
| 1201   | NOTICE OF INTENT TO CLAIM .....                                    | 56        |
| 1202   | SUBMITTAL OF CLAIMS .....  | 56        |
| 1203   | WAIVER OF CLAIMS .....   | 58        |
| <b>TITLE 13 - DISPUTES.....</b>  |  | <b>59</b> |
| 1301   | DISPUTES.....  | 59        |

|  |           |
|--|-----------|
| <b>TITLE 14 - SITE CONDITIONS .....</b>  | <b>60</b> |
| 1401    DIFFERING SITE CONDITIONS.....   | 60        |
| 1402    SITE INSPECTIONS AND INVESTIGATIONS.....                                       | 60        |
| <b>TITLE 15 - PERFORMANCE AND PAYMENT BONDS.....</b>                                   | <b>62</b> |
| 1501    SURETY BONDS .....   | 62        |
| 1502    PERFORMANCE BOND.....  | 62        |
| 1503    PAYMENT BOND.....  | 62        |
| <b>TITLE 16 - INSURANCE AND INDEMNIFICATION .....</b>                                  | <b>63</b> |
| 1601    INSURANCE.....   | 63        |
| 1602    DEFENSE AND INDEMNIFICATION .....  | 63        |
| <b>TITLE 17 - INSPECTION AND DEFECTS.....</b>  | <b>64</b> |
| 1701    CONSTRUCTION INSPECTION BY THE CITY .....                                      | 64        |
| 1702    AUTHORITY OF INSPECTORS .....  | 64        |
| 1703    OBSERVABLE DEFECTS .....   | 64        |
| 1704    DEFECTS - UNCOVERING WORK .....  | 64        |
| 1705    LATENT DEFECTS.....  | 65        |
| 1706    REMOVAL OF DEFECTIVE MATERIALS AND WORK.....                                   | 65        |
| <b>TITLE 18 - WARRANTIES, GUARANTEES AND CORRECTIVE WORK.....</b>                      | <b>66</b> |
| 1801    CONTRACTOR'S WARRANTIES, GUARANTEES AND<br>CORRECTION OF WORK.....             | 66        |
| 1802    PERFORMANCE DURING WARRANTY PERIOD.....  | 67        |
| <b>TITLE 19 - SUBSTANTIAL COMPLETION OF THE WORK.....</b>                              | <b>69</b> |
| 1901    CONTRACTOR'S NOTICE OF SUBSTANTIAL COMPLETION .....                            | 69        |
| 1902    INSPECTION AND PUNCH LIST.....   | 69        |
| 1903    CERTIFICATE OF SUBSTANTIAL COMPLETION.....                                     | 69        |
| 1904    RIGHT OF EARLY OCCUPANCY OR USE .....  | 69        |
| <b>TITLE 20 - FINAL COMPLETION AND ACCEPTANCE OF WORK .....</b>                        | <b>71</b> |
| 2001    CLEAN-UP UPON COMPLETION .....   | 71        |
| 2002    FINAL COMPLETION AND ACCEPTANCE OF THE WORK.....                               | 71        |
| 2003    FINAL SETTLEMENT .....   | 71        |
| <b>TITLE 21 - SUSPENSION OF WORK.....</b>  | <b>74</b> |
| 2101    SUSPENSION OF WORK .....   | 74        |
| 2102    SUSPENSION OF THE WORK FOR THE CITY'S CONVENIENCE .....                        | 74        |
| 2103    SUSPENSION BECAUSE OF ORDER OF CITY, STATE OR<br>FEDERAL COURT OR AGENCY ..... | 75        |
| 2104    SUSPENSION RESULTING FROM CONTRACTOR'S FAILURE TO<br>PERFORM.....              | 75        |
| <b>TITLE 22 - CITY'S RIGHT TO TERMINATE THE CONTRACT .....</b>                         | <b>76</b> |
| 2201    TERMINATION OF CONTRACT FOR CAUSE .....  | 76        |
| 2202    TERMINATION OF CONTRACT FOR CONVENIENCE OF THE CITY.....                       | 77        |
| <b>TITLE 23 - MISCELLANEOUS PROVISIONS .....</b>                                       | <b>80</b> |
| 2301    PARTIES TO THE CONTRACT.....   | 80        |
| 2302    FEDERAL AID PROVISIONS .....   | 80        |

|              |  |             |
|--------------|--|-------------|
| 2303         | NO WAIVER OF RIGHTS .....                                | 80          |
| 2304         | NO THIRD PARTY BENEFICIARY .....                         | 80          |
| 2305         | GOVERNING LAW; VENUE .....                               | 80          |
| 2306         | ABBREVIATIONS .....                                      | 81          |
| 2307         | STATUTE OF LIMITATIONS IN C.R.S. § 13-80-102(1)(h) ..... | 81          |
| <b>INDEX</b> | .....  |             |
|              | .....  | <b>i-ix</b> |

## **SPECIAL CONDITIONS**

### **SC-1 CONSTRUCTION CONTRACT GENERAL CONDITIONS**

The Construction Contract General Conditions which constitute a part of the Contract Documents are set forth in a separately published document, entitled “City and County of Denver, Department of Aviation and Department of Public Works, Standard Specifications for Construction, General Contract Conditions,” 2011 Edition, the Table of Contents to which is bound herein (which may be informally referred to as the Yellow Book). The General Conditions book is available for purchase for \$12.00 per copy at the following locations during the business hours stated, Monday through Friday, excluding holidays:

Office of the Cashier  
Wellington E. Webb Municipal Office Building, 2nd Floor  
201 West Colfax Avenue  
Denver, Colorado, USA 80202  
7:30 a.m. to 4:30 p.m.

The General Conditions are also available on the DEN Contract Procurement on the City and County of Denver website at:

<http://www.denvergov.org/constructioncontracts/ContractAdministration/ContractorResources/tabid/443154/Default.aspx>

### **SC-2 DRAWINGS AND SPECIFICATIONS TO BE FURNISHED BY THE CITY**

The City will provide the following Contract Documents to the Contractor in electronic format at no expense to the Contractor:

Document

Volumes 1 & 2 (See the Master Table of Contents, page TOC-3, for the content of these volumes)

Contract Drawings

Additional copies of the foregoing documents will be furnished to the Contractor at the Contractor’s expense. The Contractor will be responsible for supplying all subcontractors with copies of the Contract Documents at its expense.

If Sensitive Security Information (“SSI”) is provided to the Contractor, the Contractor shall be required to comply with Department of Aviation, Standard Policies and Procedures No. 6003, “Contractor Protection of Sensitive Security Information,” or its successor, and 49 C.F.R. § 1520, or its successor.

The City will not supply any copies of the General Contract Conditions to the Contractor at City expense.

### **SC-3 REVISIONS TO G.C. 201**

The second sentence of General Condition 201 is amended to read: “The unit responsible for this management and control is the Airport Infrastructure Management Office under the supervision of the Senior Vice President for Maintenance and Airport Infrastructure Management.”

### **SC-4 CITY LINE OF AUTHORITY AND CONTACTS**

In accordance with General Condition 214, the City’s line of authority for administration of this Contract is:

Chief Executive Officer (CEO). Executive Office, 9th Floor, Airport Office Building, 8500 Peña Boulevard, Denver, CO 80249. Any reference to the Manager of Aviation shall also mean Chief Executive Officer, Department of Aviation (CEO).

Executive Vice President – Chief Operating Officer (EVP-COO) who reports to the CEO. Airport Infrastructure Management office, 9th Floor, Airport Office Building, 8500 Peña Boulevard, Denver, CO 80249.

Senior Vice President - Airport Infrastructure Management (SVP-AIM) who reports to the COO. Airport Infrastructure Management office, 10th Floor, Airport Office Building, 8500 Peña Boulevard, Denver, CO 80249.

Director of Infrastructure and Quality Assurance, reports to the SVP-AIM. The Project Manager reports to the Director of Infrastructure and Quality Assurance. Airport Infrastructure Management Division, 7<sup>th</sup> Floor, Airport Office Building, 8500 Peña Boulevard, Denver, CO 80249.

Project Manager, the City representative who has day to day administrative responsibility of this Contract, and who reports to the SVP-AIM. All notices, requests, pay applications (pursuant to G.C. 902), and other correspondence from the Contractor shall be sent to the assigned Project Manager unless otherwise provided in this Contract. The Project Manager for this Contract is: Rick Zabel, Airport Infrastructure Management Office, 7th Floor, Airport Office Building, 8500 Peña Boulevard, Denver, CO 80249, phone 303-342-2663.

The CEO may from time to time substitute a different City official as the designated “SVP-AIM” hereunder, and any such change will be effective upon the issuance of written notice to the Contractor which identifies the successor SVP-AIM. The SVP-AIM may from time to time change the assigned Project Manager, and any such change will be effective upon the issuance of written notice to the Contractor which identifies the successor Project Manager.

### **SC-5 CONTRACTOR PERFORMANCE; SUBCONTRACTING**

With respect to General Condition 501, no more than 50% of the work may be subcontracted. If it is determined to be in the City’s best interest, this percentage may be modified throughout the course of the project by the SVP-AIM.



**SC-6 COOPERATION WITH OTHERS**

The Technical Specifications describe the constraints on the physical work site areas. These descriptions are not exhaustive and the Contractor is required to coordinate its activities and work as may be required to meet FAA or City requirements while performing work on DEN.

Without limiting the foregoing, the following contracts administered by the City involve or may involve work overlapping or adjoining the Work under this Contract, and may be prosecuted concurrently with the Work performed under this Contract. There may also be other adjoining or overlapping contracts which are not listed.

| <u>Contract No.</u> | <u>Description</u> |
|---------------------|--------------------|
| _____               | _____              |
| _____               | _____              |
| _____               | _____              |

**SC-7 PROSECUTION AND COMPLETION OF THE WORK:**

The Work to be performed under the Contract is described in the Technical Specifications and Contract Drawings. The Contractor shall complete the Work within one hundred forty-one (141) consecutive calendar days from Notice to Proceed.

The Work to be performed under the Contract is divided into the following Milestone Areas which are described in the Technical Specifications or Contract Drawings. The Contractor shall complete the work included within these areas within the number of days set forth below:

| <u>Milestone</u>          | <u>Date of Completion (or, days from NTP)</u> |
|---------------------------|---|
| 1. Substantial completion | 141 days from NTP                             |

**SC-8 LIQUIDATED DAMAGES**

If the Contractor fails to achieve Substantial Completion of the Work within the Contract Time, the Contractor shall be liable to the City for liquidated damages at the rate of \$5,000.00 per day until substantial completion is achieved. [Additionally, if the Contractor fails to substantially complete the Work described in a project Milestone within the time specified in SC-7 PROSECUTION AND COMPLETION OF THE WORK, the Contractor shall be liable to the City for liquidated damages at the following rates per day until such substantial completion is achieved:]

Failure to substantially complete the Work described in Milestone:

|                 |                       |
|-----------------|-----------------------|
|                 | <u>Amount per day</u> |
| 1. Construction | \$5000.00             |

Article IV of the Contract and General Condition 602 cover payment and withholding of liquidated damages.

### **SC-9 FACILITY SECURITY AND PERSONNEL ACCESS**

The Contractor shall conduct all its activities at the Airport in compliance with the Airport security system rules and regulations, which are administered by the Airport Operations Division. The Contractor shall obtain the proper access authorizations for its employees, subcontractors and suppliers (i.e., Badges and Permits), and shall be responsible for such persons' compliance with all the Airport rules and regulations. A copy of the Contractors' section of the Airport Security rules and regulations are available for Contractor review at the Airport Access Services Office, Concourse A East Subcore, 4th Level. Persons regularly entering the construction areas must obtain personnel access badges from the Airport Access Services Office and must display badges, at all times, upon entering the construction, restricted and sterile areas of the airport.. Any employee, subcontractor or supplier who violates such rules may be subject to revocation of his access authorization, including authorization for access to the construction site and all other restricted and sterile areas.

The security status of the Airport is subject to change without notice. These contract Special Conditions are applicable to the current security status of the Airport. Should the security status of the Airport change at any time during the term of this Contract, a written notice shall be issued to the Contractor detailing all applicable security modifications from the airport's current security status. The Contractor shall take **immediate steps** to comply with those security modifications as directed in the written notice.

If these security modifications involve any additional project cost, the Contractor shall submit a Contractor Change Request in accordance with the General Conditions for the additional cost. The Contractor Change Request shall outline in specific detail the effects of the security modifications on the Contractor's performance of the Contract, and shall provide a detailed cost breakdown for each item for which the Contractor is requesting reimbursement.

The Contractor shall return to the City, at contract completion or termination, or upon demand by the City, all access keys issued to it by the City to all areas of the Airport. If the Contractor fails to return any such key or keys at contract completion or termination or upon demand by the City, the Contractor shall be liable to the City for all the City's costs, including the City's labor costs for employees, incurred in re-coring doors and any other work which is required to prevent compromise of the Airport security system. In order to collect such costs hereunder, the City may withhold funds in such amount from any amounts due and payable to the Contractor under this Contract.

The construction of all the Project / Task Items that involve the breaching of any airport perimeter security boundary or continued access to restricted access rooms or areas will require the posting of authorized contract security personnel to maintain required security controls. The Contractor's **Guarantee Maximum Price / Total Contract BID Amount / Task Order Proposal** shall include the cost of providing security services to maintain control and supervision of any and all airport

perimeter security boundary breaches and for the duration of work activities where access to restricted areas is required and until the airport perimeter security boundaries are reestablished.

When security boundaries are opened for any reason, the Contractor must maintain one hundred percent (100%) control and supervision for the entire time that the openings are present to prevent unauthorized access to the secure / restricted access areas.

**THE IMPORTANCE OF THIS SPECIAL CONDITION CANNOT BE OVER-EMPHASIZED. SEVERE FINANCIAL PENALTIES AS WELL AS CONTRACT TERMINATION COULD RESULT IF AIRPORT PERIMETER SECURITY REQUIREMENTS ARE NOT STRICTLY FOLLOWED. THE REQUIREMENT TO PROVIDE ONE HUNDRED PERCENT (100%) CONTROL AND SUPERVISION OF BREACHES IN THE AIRPORT'S PERIMETER SECURITY BOUNDARY IS ABSOLUTE. AT NO TIME, DURING WORK AND NON-WORK HOURS SHALL ANY BREACHES IN THE AIRPORT'S SECURITY PERIMETER BE UNSUPERVISED AND / OR UNSECURED.**

For off-hours of construction, the Contractor may choose to erect a temporary wall to close all perimeter openings. The wall construction shall be of sufficient materials and strength to prevent access to the airport's Sterile/Restricted Areas. The Contractor shall submit for review and approval, the details and materials for the temporary closure of security perimeter breaches for review and approval.

The Contractor will provide contract security guard services to maintain supervision of these openings. The security services must provide coverage to allow for lunch breaks, comfort breaks and etc. The security services **must** be obtained from the following contract security guard company:

HSS  
900 S. Broadway, Suite 100  
Denver, Colorado 80209

DEN Contact: Kimberlie Pascoe  
(303) 342-6698

All security guards provided for this project must have a Denver Airport SIDA Badge.

The DEN Security Guard Contractor may change between the bidding or proposal phase of this contract from Notice to Proceed to closure of all security perimeter breaches. The Contractor shall maintain a contractual relationship with the Security Guard Contractor holding the most current contract with Denver International Airport.

The Contractor shall continue to provide security of these areas until such time that the breaches in the airport's security perimeter have been permanently secured.

The Contractor shall submit a written security plan for approval to the Director of Airport Security

prior to the start of construction on any work where a breach of the perimeter security boundaries is required.

#### **SC-10 CONSTRUCTION ACCESS**

The work site is located at NE Airfield, Pond 001. The Contractor shall have access to the work site via DEN inspectors.

The City will not provide parking spaces for the Contractor's employees or subcontractor employees at the Airport. Arrangements for transportation and parking for all of its and its subcontractors employees will be the responsibility of the Contractor. The Total Contract Bid Amount or Contract Amount shall include any and all costs associated with the Contractor's and subcontractors' employee parking. Information about parking facilities and charges is available from the Airport Parking Office. Refundable deposits are required for all parking passes.

Unless specifically required by the Contract Documents, the Contractor shall install no fences or other physical obstructions on or around any project work area without the approval of the City.

#### **SC-11 VEHICLE PERMITTING**

Vehicle access on the Airport Operation Area (“AOA”) is controlled by and requires permission from the Airport Access Services Office. It is not anticipated that the Contractor will need to operate vehicles on the AOA to perform the Work. Only direct construction support vehicles and/or equipment will be allowed in the contractor's work areas or sites.

#### **SC-12 VENDORS AND SUPPLIERS**

The Contractor shall provide the Project Manager's office with a list of its equipment/material vendors and suppliers. Vendors or suppliers shall access the construction work areas via the Contractor's access route, described in SC-10 above. All delivery vehicles are subject to search.

#### **SC-13 COMMUNICATION DEVICES**

Any site communications devices, mobile communication devices or internet data devices used at DEN must be approved by DEN Technologies.

#### **SC-14 USE, POSSESSION OR SALE OF ALCOHOL OR DRUGS**

The Contractor and its officers, agents, and employees shall cooperate and comply with the provisions of Executive Order No. 94 and Attachment A thereto concerning the use, possession, or sale of alcohol or drugs. Violation of these provisions or refusal to cooperate with implementation of the policy can result in the City's barring the Contractor from City facilities or participating in City operations.

### **SC-15 ATTORNEY'S FEES**

Colorado Revised Statute 38-26-107 requires that in the event any person or company files a verified statement of amounts due and unpaid in connection with a claim for labor and materials supplied on this project, the City shall withhold from payments to the Contractor sufficient funds to insure the payment of any such claims. Should the City and County of Denver be made a party to any lawsuit to enforce such unpaid claims or any lawsuit arising out of or relating to such withheld funds, Contractor agrees to pay to the City its costs and a reasonable attorney's fee. Because the City Attorney Staff does not bill the City for legal services on an hourly basis, Contractor agrees a reasonable fee shall be computed at the rate of one hundred dollars per hour of City Attorney time.

### **SC-16 INSURANCE REQUIREMENTS**

In accordance with the provisions of Title 16 of the General Conditions, the minimum insurance requirements for this contract are set forth in the Exhibit Q, attached to this Contract. The Contractor specifically agrees to comply with each condition, requirement or specification set forth in the attachment for each required coverage during all periods when the required coverage's are in effect.

City anticipates providing a Rolling Owner Controlled Insurance Program (ROCIP), which coverage City agrees will be primary over any other insurance provided by an enrolled party. City agrees to allow Contractor to review all proposed coverage forms prior to implementation of the ROCIP. Following implementation of the ROCIP, Contractor agrees to provide a credit to the City for the cost of insurance coverage being provided by the ROCIP. The amount of such credit will be determined based upon a review of actual ROCIP coverages. The City shall be named as an additional insured on Contractor's general liability policy in the event that Contractor includes the costs of said coverage in its bid.

Contractor and sub-contractors shall procure and maintain until all of their obligations have been discharged, including any warranty periods under this Contract are satisfied, required insurance against claims for injury to persons or damage to property which may arise from or in connection with the performance of the work hereunder by the Contractor, his agents, representatives, employees or sub-contractors.

The insurance requirements herein are minimum requirements for this Contract and in no way limit the indemnity covenants contained in this Contract.

The City and County of Denver in no way warrants that the minimum limits contained herein are sufficient to protect the Contractor from liabilities that might arise out of the performance of the work under this Contract by the Contractor, his agents, representatives, employees or sub-contractors. The Contractor shall assess its own risks as it deems appropriate and/or prudent, maintain higher limits and/or broader coverages. The Contractor is not relieved of any liability or other obligations assumed or pursuant to the Contract by reason of its failure to obtain or maintain insurance in sufficient amounts, duration or types.

Contractor shall furnish the City and County of Denver with certificates of insurance (ACORD form or equivalent approved by CCD) as required by this Contract. The certificates for each insurance policy are to be signed by a person authorized by the insurer to bind coverage on its behalf.

All certificates and any required endorsements are to be received and approved by the City before work commences. Each insurance policy required by this Contract must be in effect at or prior to commencement of work under this Contract and remain in effect for the duration of the project. Failure to maintain the insurance policies as required by this Contract or to provide evidence of renewal is a material breach of the Contract. All insurance coverages for sub-contractors shall be subject to the minimum requirements identified in the Exhibit. All sub-contractors certificates and endorsements shall be received and approved by the Contractor before work commences. The City reserves the right to request copies of these certificates at any time.

All certificates required by this Contract shall be sent directly to Denver International Airport, Business Management Services, Airport Office Building, Room 8810, 8500 Pena Boulevard, Denver, Colorado 80249. The City project/Contract number and project description shall be noted on the certificate of insurance. The City reserves the right to require complete, certified copies of all insurance policies required by this Contract at any time.

The parties hereto understand and agree that the City and County of Denver, its officers, officials and employees, are relying on, and do not waive or intend to waive by any provisions of this Contract, the monetary limitations or any other rights, immunities and protections provided by the Colorado Governmental Immunity Act, §§ 24-10-101 - 120, C.R.S., or otherwise available to the City and County of Denver, its officers, officials and employees.

#### **SC-17 SUBCONTRACTOR RELEASES**

The release form referred to in General Condition 907 is attached to this Contract. It is entitled "Denver International Airport Partial Release."

#### **SC-18 ADDITIONAL AFFIRMATIVE ACTION REQUIREMENTS, FEDERAL PROVISIONS**

This contract is subject and subordinate to the terms, reservations, restrictions, and conditions of any existing or future agreements between the City and the United States, the execution of which has been or may be required as a condition precedent to the transfer of federal rights or property to the City for airport purposes, and the expenditure of federal funds for airport purposes. The "Federal Requirements" section attached hereto is made a part of this Contract.

#### **SC-19 ESTIMATED QUANTITIES OF UNIT PRICED ITEMS**

The "total estimated quantity" of each unit price item as stated on the bid schedules shall be the estimated quantity which is used to determine the percentage of change in such item for purposes of G.C. 1104.7.

## **SC-20 REVISIONS TO G.C. 1102**

G.C. 1102.2 is amended by replacing the phrase “Change Request” in all its occurrences in such G.C. with the phrase “Change Notice.”

G.C. 1102.3 is amended by replacing the phrase “Field Order/Change Order Directive” in all its occurrences in such G.C. with the phrase “Change Order Directive.”

## **SC-21 LISTING OF ACCEPTABLE MANUFACTURERS**

The Technical Specifications list “Acceptable Manufacturers” for certain products. Such listing identifies manufacturers of certain products which have been determined by a preliminary review to be able to meet the basic product and/or system technical requirements. The listing is not intended to provide a blanket endorsement or acceptance of the manufacturer’s specified products or product line. All products from listed manufacturers must meet the detailed requirements of the Technical Specifications. Products that do not meet all detailed Technical Specifications are not acceptable and will be rejected, regardless of whether the manufacturer was listed as “acceptable.” The Contractor is responsible for determining the acceptability of all products under the Technical Specifications prior to submission of products for approval.

## **SC-22 ACCESSIBLE PARKING SPACES, ACCESS AISLES AND ROUTES OF TRAVEL**

If any Work is performed in or adjacent to parking facilities at the Airport, the Contractor is responsible for compliance with this SC-30. “Accessible” parking spaces and access aisles as used in this SC-30 mean parking spaces and access aisles which are accessible for, and reserved for use by, persons with disabilities. These parking spaces and access aisles are designed and built to standards established by federal regulations implementing the Americans with Disabilities Act of 1990 (“ADA”), and are marked by signage. “Accessible routes of travel” as used herein means routes through parking facilities which comply with ADA accessibility standards, including degree of slope and absence of obstructions.

Accessible routes of travel and accessible parking spaces and access aisles must be kept free of obstructions and construction debris at all times. No accessible parking spaces or access aisles or accessible routes of travel shall be relocated, blocked or rendered unusable unless the contractor has obtained specific advance approval in writing for such actions from the airport’s ADA Compliance Officer.

When prosecution of the Work requires that accessible spaces be temporarily blocked, those accessible spaces and their access aisles shall be temporarily relocated to another location as close as possible to an accessible building entrance. Temporary signage that identifies these parking spaces and access aisles as reserved for the handicapped shall be installed, and the accessible route shall be clearly marked as required.

Before blocking or relocating accessible parking spaces or accessible routes of travel, the contractor must obtain written approval from the DEN ADA Compliance Officer, by submitting a completed request form, which will be provided to the Contractor by the Project Manager at the

preconstruction meeting if it is not included as a standard form in Section 019990 of the Technical Specifications. The request shall include the location of alternative spaces and/or routes, and specifications of the temporary signage to be used. Work shall not proceed without this approval.

If a vehicle is parked in any accessible space which is either temporary or approved to be relocated, the contractor will not remove signage or take any other action which would allow the access aisle for such parking space to be blocked. Such actions must be postponed until the parking space is no longer occupied.

**SC-23 SUBCONTRACTOR PAYMENTS AND SUBCONTRACTOR RELEASES – REQUIRED USE OF THE B2G CONTRACT MANAGEMENT SYSTEM**

The Contractor is required to use the City B2G Contract Management System to report all subcontractor payments and shall adhere to the City’s Procedure for Reporting Subcontractor Payments. It is the Contractor’s obligation to ensure that complete subcontractor information is entered into the B2G System prior to submission of the first application for payment in order to avoid any delays in payment. The Contractor shall, prior to the submission of each subsequent invoice, ensure payments to subcontractors have been entered into the B2G System, including subcontractor confirmation of amount of payment received, for services performed during the prior billing period.

**SC-24 PAYMENTS TO CONTRACTORS**

The Contractor recognizes and agrees that applications for payment shall be submitted using the Textura® Construction Payment Management System (CPM System), which will also be the payment mechanism to disburse payments to sub-contractors used on this Project. For more information, please refer to Division I, Technical Specifications.

The Contractor further agrees that, to the fullest possible within the CPM System, the City shall be entitled to all non-Confidential records, reports, data and other information related to the project that are available to Contractor through the CPM System, including, but not limited to, information related to Contractor and subcontractor billings. To that end, Contractor agrees that it will activate any available settings within the CPM System that are necessary to grant the City access to such non-Confidential information related to the contract and the project. Applications for payment shall be based on the Contract Unit Prices or the approved Schedule of Values described in GC 903.1

In accordance with General Contract Condition 902, PAYMENT PROCEDURE, The party(ies) responsible for review of all Pay Applications shall be:

**Agency/Firm**  
DEN Division CA  
DEN Division PM  
DEN Division Director  
DEN Contract Svcs CA  
CCD Denver Prevailing Wage



In accordance with General Contract Condition 906, APPLICATIONS FOR PAYMENT, each Application submitted shall include the following:

1. The estimate of Work completed shall be based on the approved schedule of values or unit prices, as applicable, and the percent of the Work complete.
2. Each Application for Payment shall include each and every independent subcontractor's payroll information including pay dates and pay amounts.
3. The Contractor shall also submit to the Auditor and other appropriate officials of the City in a timely fashion, information required by General Contract Condition 1004, REPORTING WAGES PAID.

In accordance with General Contract condition 907, RELEASES AND CONTRACTORS CERTIFICATION OF PAYMENT, applications for Payment must be accompanied by completed Partial or Final Claim Release Form, as appropriate, from EACH subcontractor and supplier, **AND** the Contractor's Certification of Payment Form.

# INSURANCE CERTIFICATE OR REQUIREMENTS

The insurance requirements which apply to this contract are listed below:

**The following links contains important information about the Rolling Owner-Controlled Insurance Program (ROCIP) to ensure that all costs are captured within your bid proposal.**

**1. ROCIP III Insurance Manual**

[http://business.flydenver.com/bizops/documents/den\\_ROCIPIII\\_template.dotx](http://business.flydenver.com/bizops/documents/den_ROCIPIII_template.dotx)

**2. ROCIP Safety Manual**

[http://business.flydenver.com/bizops/documents/den\\_ROCIPIII\\_Safety\\_Manual.docx](http://business.flydenver.com/bizops/documents/den_ROCIPIII_Safety_Manual.docx)



**DENVER INTERNATIONAL AIRPORT  
PARTIAL LIEN RELEASE – CONSTRUCTION  
(Subcontractor)**

Project: \_\_\_\_\_

Date: \_\_\_\_\_

City Contract No. \_\_\_\_\_

Current Subcontract  
Amount: \$ \_\_\_\_\_

FROM:  
Subcontractor \_\_\_\_\_

(1) Last Progress Payment for billing  
period ending \_\_\_\_\_ 20\_\_\_\_

Address: \_\_\_\_\_

\$ \_\_\_\_\_

City/State: \_\_\_\_\_ (2) Progress invoiced for previous billing period (if unpaid) \_\_\_\_\_ 20\_\_\_\_

Telephone: \_\_\_\_\_ \$ \_\_\_\_\_

TO: Contractor \_\_\_\_\_ (3) Progress invoiced for current billing period ending \_\_\_\_\_ 20\_\_\_\_

Address: \_\_\_\_\_ \$ \_\_\_\_\_

City/State: \_\_\_\_\_ (4) **Total Paid to Date:**  
\$ \_\_\_\_\_

( ) MBE/WBE ( ) SBE ( ) DBE ( ) Non

The Undersigned hereby certifies that all costs, charges or expenses incurred by the undersigned or on behalf of the undersigned for any work, labor or services performed and for any materials, supplies or equipment provided on the above referenced Project or used in connection with the above referenced Subcontract (the "Work Effort") have been duly paid in full to date.

The Undersigned further certifies that each of the undersigned's subcontractors and suppliers that incurred or caused to be incurred, on their behalf, costs, charges or expenses in connection with the undersigned's Work Effort on the above referenced Project have been duly paid in full to date.

The Undersigned hereby (1) acknowledges receipt of the progress payment referred to above as the Last Progress Payment which, when added to the total of all previous progress payments, constitutes full payment, less retainage, for all labor, services, material and supplies which the undersigned has provided for use in and upon the project described above through \_\_\_\_\_, 20\_\_\_\_ and, (2) hereby releases the Contractor, surety, the City and County of Denver, and any intermediate subcontractor or supplier of any tier from any and all claims prior to the above mentioned date, except for the withheld retainage.

The Undersigned also hereby agrees that the Contractor, Surety, the City and County of Denver, and any intermediate subcontractor or supplier of any tier shall be released from any and all claims arising out of its performance or non-performance of any contract associated with the above project through \_\_\_\_\_, 20\_\_\_\_, except for withheld retainage after it has received full payment, less retainage, of the amount invoiced for the current billing period.

As additional consideration for the payments referenced above, the undersigned agrees to defend, indemnify and hold harmless the City, its officers, employees, agents and assigns and the above-referenced Contractor from and against all costs, losses, damages, causes of action, judgments under the subcontract and expenses arising out of or in connection with any claim or claims against the City or the Contractor which arise out of the Undersigned's performance of the Work Effort and which may be asserted by the Undersigned or any of its suppliers or subcontractors of any tier or any of their representatives, officers, agents, or employees.

It is acknowledged that this release is for the benefit of and may be relied upon by the City and the referenced Contractor.

The foregoing shall not relieve the undersigned of any obligation under the provisions of the Undersigned's subcontract, as the subcontract may have been amended, which by their nature survive completion of the Undersigned's work effort including, without limitation, warranties, guarantees, insurance requirements and indemnities.

Subcontractor: \_\_\_\_\_

Certified by: \_\_\_\_\_

Title: \_\_\_\_\_

Date: \_\_\_\_\_



# DENVER INTERNATIONAL AIRPORT FINAL LIEN RELEASE – CONSTRUCTION (Subcontractor)

Project: \_\_\_\_\_

Date: \_\_\_\_\_

City Contract No. \_\_\_\_\_

Subcontractor Contract No. \_\_\_\_\_

FROM:  
Subcontractor: \_\_\_\_\_

Dated: \_\_\_\_\_, 20\_\_

(1) Last Progress Payment for billing  
period ending \_\_\_\_\_, 20\_\_

Address: \_\_\_\_\_

\$ \_\_\_\_\_

City/State: \_\_\_\_\_

(2) Does not apply

Telephone: \_\_\_\_\_

TO:  
Contractor: \_\_\_\_\_

(3) Does not apply

Address: \_\_\_\_\_

City/State: \_\_\_\_\_

(4) **Total Paid to Date:**

\$ \_\_\_\_\_

SBE       DBE       MBE       WBE       Non

The Undersigned hereby certifies that all costs, charges or expenses incurred by the undersigned or on behalf of the undersigned for any work, labor or services performed and for any materials, supplies or equipment provided on the above referenced Project or used in connection with the above referenced Subcontract (the "Work Effort") have been duly paid in full.

The Undersigned further certifies that each of the undersigned's subcontractors and suppliers that incurred or caused to be incurred, on their behalf, costs, charges or expenses in connection with the undersigned's Work Effort on the above referenced Project have been duly paid in full.

The undersigned Subcontractor hereby (1) acknowledges receipt of the progress payment referred to above as the Last Progress Payment which, when added to the total of all previous progress payments, constitutes full payment for all labor, services, materials and supplies which the undersigned has provided for use in and upon the project described above through \_\_\_\_\_, 20\_\_ and, (2) hereby releases the Contractor, Surety, the City and County of Denver, and any intermediate subcontractor or supplier of any tier from any and all claims prior to the above mentioned date.

The Subcontractor also hereby agrees that the Contractor, Surety, the City and County of Denver, and any intermediate subcontractor or supplier of any tier shall be released from any and all claims arising out of its performance or non-performance of any contract associated with the above project.

As additional consideration for the payments referenced above, the undersigned agrees to defend, indemnify and hold harmless the City, its officers, employees, agents and assigns and the above-referenced Contractor from and against all costs, losses, damages, causes of action, judgments under the subcontract and expenses arising out of or in connection with any claim or claims against the City or the Contractor which arise out of the Undersigned's performance of the Work Effort and which may be asserted by the Undersigned or any of its suppliers or subcontractors of any tier or any of their representatives, officers, agents, or employees.

It is acknowledged that this release is for the benefit of and may be relied upon by the City and the referenced Contractor.

The foregoing shall not relieve the undersigned of any obligation under the provisions of the Undersigned's subcontract, as the subcontract may have been amended, which by their nature survive completion of the Undersigned's work effort including, without limitation, warranties, guarantees, insurance requirements and indemnities.

Subcontractor: \_\_\_\_\_

Certified by: \_\_\_\_\_

Title: \_\_\_\_\_

Date: \_\_\_\_\_

**CITY AND COUNTY OF DENVER  
RULES AND REGULATIONS AND BID CONDITIONS  
OF THE  
MANAGER OF PUBLIC WORKS**

**PERTAINING TO EQUAL EMPLOYMENT OPPORTUNITY  
IN THE CITY AND COUNTY OF DENVER**

APPROVED FOR LEGALITY

APPROVED AND ADOPTED:

/s/

/s/

---

Attorney for the City and County of Denver

---

Manager of Public Works

Adopted and Published Pursuant to Article III, Division 2 of Chapter 28  
of the  
*Revised Municipal Code*  
of the  
City and County of Denver

These Rules and Regulations cancel  
and supersede any and all previously  
issued Rules and Regulations on the Subject.

Revised November 1, 1990



RULES AND REGULATIONS  
REGARDING  
EQUAL EMPLOYMENT OPPORTUNITY

Promulgated and adopted by the Manager of Public Works pursuant to and by authority of Article III, Division 2, Chapter 28 of the Revised Municipal Code of the City and County of Denver, and for the purpose of insuring that contractors, subcontractors and suppliers soliciting and receiving compensation for contract work from or through the City and County of Denver provide equal opportunity in employment without regard to race, color, creed, sex, national origin, age religion, material status, political opinion or affiliation or mental or physical handicap and meet certain requirements for the hiring, training, promotion, and treatment during employment of members of ethnic groups subject to differential treatment, including persons of African descent (Black), Spanish-surnamed (Hispanic), Asian-American and American Indian Groups.

RULE I – DEFINITIONS

- A. “City” means the City and County of Denver.
- B. “Manager” means the Manager of Public Works for the City and County of Denver.
- C. “Contract” means a contract entered into with the City and County of Denver, financed in whole or in part by local resources or funds of the City and County of Denver, for the construction of any of any public building or prosecution or completion of any public work.
- D. “Contractor” means the original party to a contract with the City and County of Denver, also referred to as the "general" or "prime" contractor.
- E. “Director” means the Director of Contract Compliance.
- F. “Subcontractor” means any person, company, association, partnership, corporation, or other entity which assumes by subordinate agreement some or all of the obligations of the general or prime contractor.
- G. “Bidding Specifications” as used in Article III, Division 2 of Chapter 28 of the Revised Municipal Code shall include BID CONDITIONS, INVITATION TO BID, and NOTICE OF PROPOSAL.
- H. “Affirmative Action Program” means a set of specific and result-oriented procedures or steps to which a contractor commits himself to apply every good faith effort to employ members of ethnic minority groups, to include persons of African descent (Black), Spanish surnamed (Hispanic), Asian-American, American Indians, and persons with mental or physical handicap.
- I. “Office of Contract Compliance” means the City agency established pursuant to Article III, Division 1 of Chapter 28 of the Denver Revised Municipal Code.

RULE II – NOTICE OF HEARING

When results of conciliation efforts are unsatisfactory to the Manager and he is informed in accordance with Article III, Division 2 of Chapter 28 of the Denver Revised Municipal code that a contractor or subcontractor has apparently failed to meet affirmative action and equal employment opportunity requirements after a reasonable period of notice to correct deficiencies, the Manager will, prior to imposition of any sanctions, afford the general contractor a hearing in order to determine whether the contractor or his subcontractors have failed to comply with the affirmative action and equal employment opportunity requirements of Article III, Division 2 of Chapter 28 of the Denver Revised Municipal Code or of the contract. Written notice of such hearing shall be delivered personally or sent by certified mail, return receipt requested, to the contractor and to any subcontractor involved, at least ten (10) days prior to the date scheduled for the hearing.

### RULE III – HEARING

- A. Contractors will appear at hearings and may be represented by counsel, and may present testimony orally and other evidence.
- B. Hearings shall be conducted by one or more hearing examiners designated as such by the Manager.
- C. The Director of Contract Compliance may participate in hearings as a witness.
- D. Hearings shall be held at the place specified in the notice of hearing.
- E. All oral testimony shall be given under oath or affirmation and a record of such proceedings shall be made.
- F. All hearings shall be open to the public.
- G. The hearing officer shall make recommendations to the Manager, who shall make a final decision.

### REGULATIONS

#### REGULATION NO. 1 - ORDINANCE

The Rules and Regulations of the Manager shall be inserted in the bidding specifications for every contract for which bidding is required.

#### REGULATION NO. 2 - EXEMPTIONS

Each contract and subcontract, regardless of the dollar amount, shall be subject to affirmative action requirements unless specifically exempted in writing individually by the Manager. Exemptions apply only to "affirmative action" in equal employment opportunity, and are not to be construed as condonation in any manner of "discrimination" or "discriminatory practices" in

employment because of race, color, creed, sex, age, national origin, religion, marital status, political opinion or mental or physical handicap.

#### REGULATION NO. 3 - DIRECTOR OF CONTRACT COMPLIANCE

The Director of Contract Compliance shall perform the duties assigned to such official by Article III, Division 2 Chapter 28 of the Denver Revised Municipal Code and by the Manager. The Director of Contract Compliance or designated representatives shall inform bidders and contractors of affirmative action procedures, programs, and goals in accordance with the Ordinance at pre-bid and pre-construction conference; (2) make regular on-site inspections; (3) supply contractors and subcontractors with report forms to be completed by them when requested, and furnished to the Director of Contract Compliance; and (4) review payroll records, employment records and practices of general contractors and their subcontractors and suppliers during the performance of any contract. The Director of Contract Compliance shall promptly report apparent affirmative action deficiencies to the Manager.

#### REGULATION NO. 4 - GOALS AND TIMETABLES

In general, goals and timetables should take into account anticipated vacancies and the availability of skills in the market place from which employees should be drawn. In addition, where discrimination in employment by a general contractor or any of his subcontractors is indicated, a corrective action program will take into account the need by the general contractor and his subcontractors to correct past discriminatory practices and reach goals of minority manpower utilization on a timely basis through such recruiting and advertising efforts as are necessary and appropriate.

#### REGULATION NO. 5 - AWARD OF CONTRACTS.

It shall be the responsibility of the Director of Contract Compliance to determine the affirmative action capability of bidders, contractors and subcontractors and to recommend to the Manager the award of contracts to those bidders, contractors and subcontractors and suppliers who demonstrate the ability and willingness to comply with the terms of their contract.

#### REGULATION NO. 6 - PUBLICATION AND DUPLICATION.

Copies of these Rules and Regulations as amended by the Manager from time to time, shall as soon as practicable and after Notice being published will be made a part of all City Contracts.

#### REGULATION NO. 7 - NOTICE TO PROCEED.

Prior to issuance of the Notice to Proceed, a sign-off will be required of the Director of Contract Compliance or his designee.

#### REGULATION NO. 8 - CONTRACTS WITH SUBCONTRACTORS.

To the greatest extent possible, the contractor shall make a good faith effort to contract with minority contractors, subcontractors and suppliers for services and supplies by taking affirmative actions which include but are not limited to the following:

1. Advertise invitations for subcontractor bids in minority community news media.
2. Contact minority contractor organizations for referral of prospective subcontractors.
3. Purchase materials and supplies from minority material suppliers.

#### REGULATION NO. 9 - AGENCY REFERRALS.

It shall be no excuse that the union with which the contractor or subcontractor has an agreement providing for referral, exclusive or otherwise, failed to refer minority employees.

#### REGULATION NO. 10 - CLAUSES.

The Manager shall include the appropriate clauses in every contract, and the contractor shall cause to be inserted in every subcontract the appropriate clauses:

1. APPENDIX A: City and County of Denver Equal Opportunity Clause - ALL CONTRACTS funded only with City and County of Denver monies.
2. APPENDIX B: Equal Opportunity Clause (11246) - ALL FEDERAL ASSISTED.
3. APPENDIX C: Section 3 - Assurance of Compliance - HUD ASSISTED PROJECTS.
4. APPENDIX D: Section 3 - Clause - HUD ASSISTED PROJECTS.

#### REGULATION NO. 11 - SHOW CAUSE NOTICES.

When the Manager has reasonable cause to believe that a contractor has violated Article III, Division 2 of Chapter 28 of the Denver Revised Municipal Code, he may issue a notice requiring the contractor to show cause within 15 days why enforcement procedures, or other appropriate action to insure compliance, should not be instituted.

#### REGULATION NO. 12 - BID CONDITIONS - AFFIRMATIVE ACTION REQUIREMENTS - EQUAL EMPLOYMENT OPPORTUNITY.

1. APPENDIX E: The Bid Conditions - Affirmative Action Requirements - Equal Employment Opportunity as amended and published by the U.S. Department of Labor Employment Standards Administration, Office of Federal Contract

Compliance, shall be inserted verbatim for bidding specification in every non-exempt contract involving the use of federal funds.

2. APPENDIX F: The Bid Conditions - Affirmative Action Requirements - Equal Employment Opportunity as published by the Department of Public Works, City and County of Denver, shall be inserted verbatim as bidding specifications for every non-exempt contract using City funds.

## **Appendix No. 1**

### **Standard Federal Assurances and Nondiscrimination**

# APPENDIX 1(A)

## COMPLIANCE WITH NONDISCRIMINATION REQUIREMENTS

NOTE: As used below the term "Contractor" shall mean and include Concessionaire, and the term "sponsor" shall mean the "City." During the term of this Contract, the Contractor, for itself, its assignees and successors in interest (hereinafter referred to as the "Contractor") agrees as follows:

- 1. Compliance with Regulations.** The Contractor will comply with the Title VI List of Pertinent Non-Discrimination Statutes and Authorities, as they may be amended from time to time, which are herein incorporated by reference and made part of this Agreement.
- 2. Nondiscrimination.** The Contractor, with regard to the work performed by it during this Agreement, will not discriminate on the grounds of race, creed, color, national origin, or sex in the selection and retention of subcontractors, including procurements of materials and leases of equipment. The Contractor will not participate directly or indirectly in the discrimination prohibited by the Acts and Regulations, including employment practices when the Agreement covers any activity, project, or program set forth in Appendix B of 49 CFR Part 21.
- 3. Solicitations for Subcontractors, Including Procurements of Materials and Equipment.** In all solicitations, either by competitive bidding or negotiation, made by the Contractor for work to be performed under a subcontract, including procurements of materials or leases of equipment, each potential subcontractor or supplier will be notified by the Contractor of the Contractor's obligations under this Agreement and the Acts and Regulations relative to nondiscrimination on the grounds of race, color, or national origin.
- 4. Information and Reports.** The Contractor will provide all information and reports required by the Acts, Regulations or directives issued pursuant thereto and will permit access to its books, records, accounts other sources of information, and its facilities as may be determined by the sponsor or the Federal Aviation Administration (FAA) to be pertinent to ascertain compliance with such Acts, Regulations, and instructions. Where any information required of a Contractor is in the exclusive possession of another who fails or refuses to furnish this information, the Contractor shall so certify to the sponsor or the FAA, as appropriate, and will set forth what efforts it has made to obtain the information.
- 5. Sanctions for Noncompliance.** In the event of a Contractor's noncompliance with the nondiscrimination provisions of this Agreement, the sponsor will impose such Contract sanctions as it or the FAA may determine to be appropriate, including, but not limited to:

  - a. Withholding of payments to the Contractor under this Agreement until the Contractor complies, and/or;
  - b. Cancelling, terminating, or suspending this Agreement, in whole or in part.
- 6. Incorporation of Provisions.** The Contractor will include the provisions of paragraphs one (1) through six (6) in every subcontract, including procurements of materials and leases of equipment, unless exempt by the Acts, the Regulations or directives issued pursuant thereto. The Contractor will take action with respect to any subcontract or procurement as the sponsor or the FAA may direct as a means of enforcing such provisions including sanctions for noncompliance. Provided,

that if the Contractor becomes involved in, or is threatened with litigation by a subcontractor, or supplier because of such direction, the Contractor may request the sponsor to enter into such litigation to protect the interests of the sponsor. In addition, the Contractor may request the United States to enter into such litigation to protect the interests of the United States.



## APPENDIX 1(C)

### STANDARD FEDERAL ASSURANCES AND NONDISCRIMINATION IN CONSTRUCTION, MAINTENANCE, OPERATION OF FACILITIES

As used below, the term “sponsor” will mean City.

Concessionaire, for himself/herself, his/her heirs, personal representatives, successors in interest, and assigns, as part of consideration hereof, does hereby covenant and agree, as a covenant running with the land that:

1. In the event facilities are constructed, maintained, or otherwise operated on the property described in this Agreement for a purpose for which a FAA activity, facility, or program is extended or for another purpose involving the provision of similar services or benefits, the Concessionaire will maintain and operate such facilities and services in compliance with all requirements imposed by the Nondiscrimination Acts and Regulations listed in the Pertinent List of Nondiscrimination Authorities, as may be amended from time to time, such that no person on the grounds of race, color, or national origin, will be excluded from participation in, denied the benefits of, or be otherwise subjected to discrimination in the use of said facilities.
2. With respect to this Agreement, in the event of breach of any of the above Nondiscrimination covenants, sponsor will have the right to terminate this Agreement, and to enter, re-enter, and repossess said lands and facilities thereon, and hold the same as if this Agreement had never been made or issued.

## APPENDIX 1(D)

### STANDARD FEDERAL ASSURANCES AND NONDISCRIMINATION IN CONSTRUCTION, USE, OR ACCESS TO FACILITIES

As used below, the term “sponsor” will mean City.

- A. Concessionaire for himself/herself, his/her heirs, personal representatives, successors in interest, and assigns, as part of the consideration hereof, does hereby covenant and agree, as a covenant running with the land, that (1) no person on the ground of race, color, or national origin, will be excluded from participation in, denied the benefits of, or be otherwise subjected to discrimination in the use of said facilities, (2) that in the construction of any improvements on, over, or under such land, and the furnishing of services thereon, no person on the ground of race, color, or national origin, will be excluded from participation in, denied the benefits of, or otherwise be subjected to discrimination, (3) that the Concessionaire will use the Premises in compliance with all other requirements imposed by or pursuant to the List of Pertinent Nondiscrimination Authorities.
- B. With respect this Agreement, in the event of breach of any of the above nondiscrimination covenants, sponsor will have the right to terminate this Agreement and to enter, re-enter, and repossess said land and the facilities thereon, and hold the same as if this Agreement had never been made or issued.

## APPENDIX 1(E)

### TITLE VI LIST OF PERTINENT NONDISCRIMINATION AUTHORITIES

As used below, the term "Contractor" will mean and include Concessionaire and the term "sponsor" will mean City.

During the performance of this Agreement, the Contractor, for itself, its assignees, and successors in interest (hereinafter referred to as the "Contractor") agrees to comply with the following nondiscrimination statutes and authorities; including but not limited to:

- Title VI of the Civil Rights Act of 1964 (42 U.S.C. § 2000d *et seq.*, 78 stat. 252), (prohibits' discrimination on the basis of race, color, national origin);
- 49 CFR part 21 (Non-discrimination In Federally-Assisted Programs of The Department of Transportation-Effectuation of Title VI of The Civil Rights Act of 1964);
- The Uniform Relocation Assistance and Real Property Acquisition Policies Act of 1970, (42 U.S.C. § 4601 ), (prohibits unfair treatment of persons displaced or whose property has been acquired because of Federal or Federal-aid programs and projects);
- Section 504 of the Rehabilitation Act of 1973, (29 U.S. C. § 794 *et seq.*), as amended, (prohibits discrimination on the basis of disability); and 49 CFR part 27;
- The Age Discrimination Act of 1975, as amended, (42 U.S.C. § 6101 *et seq.*), (prohibits discrimination on the basis of age);
- Airport and Airway Improvement Act of 1982, (49 USC§ 471, Section 47123), as amended, (prohibits discrimination based on race, creed, color, national origin, or sex);
- The Civil Rights Restoration Act of 1987, (PL 1 00-209), (Broadened the scope, coverage and applicability of Title VI of the Civil Rights Act of 1964, The Age Discrimination Act of 1975 and Section 504 of the Rehabilitation Act of 1973, by expanding the definition of the terms "programs or activities" to include all of the programs or activities of the Federal-aid recipients, sub-recipients and Contractors, whether such programs or activities are Federally funded or not);
- Titles II and III of the Americans with Disabilities Act of 1990, which prohibit discrimination on the basis of disability in the operation of public entities, public and private transportation systems, places of public accommodation, and certain testing entities (42 U.S.C. §§ 12131 -12189) as implemented by Department of Transportation regulations at 49 CFR parts 37 and 38;
- The Federal Aviation Administration's Non-discrimination statute (49 U.S.C. § 47123) (prohibits discrimination on the basis of race, color, national origin, and sex);
- Executive Order 12898, Federal Actions to Address Environmental Justice in Minority Populations and Low-Income Populations, which ensures discrimination against minority populations by discouraging programs, policies, and activities with disproportionately high and adverse human health or environmental effects on minority and low-income populations;

- Executive Order 13166, Improving Access to Services for Persons with Limited English Proficiency, and resulting agency guidance, national origin discrimination includes discrimination because of limited English proficiency (LEP). To ensure compliance with Title VI, you must take reasonable steps to ensure that LEP persons have meaningful access to your programs (70 Fed. Reg. at 74087 to 74100);
- Title IX of the Education Amendments of 1972, as amended, which prohibits you from discriminating because of sex in education programs or activities (20 U.S. C. 1681 et seq).

## APPENDIX 2

### DISADVANTAGED BUSINESS ENTERPRISES- REQUIRED STATEMENTS

As used below, the term "Contractor" will mean and include Concessionaire and the term "sponsor" will mean City.

**Contract Assurance (§ 26.13)** – The Contractor or subcontractor will not discriminate on the basis of race, color, national origin, or sex in the performance of this Contract. The Contractor will carry out applicable requirements of 49 CFR Part 26 in the award and administration of DOT assisted Contracts. Failure by the Contractor to carry out these requirements is a material breach of this Contract, which may result in the termination of this Contract or such other remedy, as the recipient deems appropriate.

**Prompt Payment (§26.29)** – The prime Contractor agrees to pay each subcontractor under this prime Contract for satisfactory performance of its Contract no later than thirty (30) days from the receipt of each payment the prime Contractor receives from Contractor. The prime Contractor agrees further to return retainage payments to each subcontractor within thirty (30) days after the subcontractor's work is satisfactorily completed. Any delay or postponement of payment from the above referenced time frame may occur only for good cause following written approval of the sponsor. This clause applies to both DBE and non-DBE subcontractors.

# PROJECT MANUAL



DENVER  
INTERNATIONAL  
AIRPORT

**Pond 001 Expansion**  
CONTRACT NO. 201737313

## PART I

### GENERAL REQUIREMENTS

*Issued for Construction November 21, 2017*

CITY & COUNTY OF DENVER  
DEPARTMENT OF AVIATION



**TABLE OF CONTENTS  
TECHNICAL SPECIFICATIONS**

**DIVISION 1 – GENERAL REQUIREMENTS**

| <u>SECTIONS</u> | <u>TITLE</u>   |
|-----------------|--|
| 011100          | SUMMARY OF WORK  |
| 011400          | WORK SEQUENCE AND CONSTRAINTS                                |
| 011420          | SECURITY REQUIREMENTS & SENSITIVE SECURITY INFORMATION (SSI) |
| 011430          | VEHICLE AND EQUIPMENT PERMITTING                             |
| 011810          | UTILITIES INTERFACE  |
| 012510          | SUBSTITUTIONS  |
| 012910          | SCHEDULE OF VALUES   |
| 013100          | PROJECT MANAGEMENT AND COORDINATION                          |
| 013119          | PROJECT MEETINGS   |
| 013210          | SCHEDULE   |
| 013223          | CONSTRUCTION LAYOUT, AS-BUILT AND QUANTITY SURVEYS           |
| 013233          | PHOTOGRAPHIC DOCUMENTATION                                   |
| 013300          | SUBMITTAL PROCEDURES   |
| 013325          | SHOP AND WORKING DRAWINGS, PRODUCT DATA, AND SAMPLES         |
| 013510          | CONSTRUCTION SAFETY  |
| 013520          | CONSTRUCTION SAFETY - AIRSIDE                                |
| 014100          | REGULATORY REQUIREMENTS                                      |
| 014210          | REFERENCED MATERIAL  |
| 014220          | ABBREVIATIONS AND SYMBOLS                                    |
| 014225          | REFERENCE STANDARDS  |
| 014230          | DEFINITIONS AND CONVENTIONS                                  |
| 014510          | CONTRACTOR QUALITY CONTROL                                   |
| 014525          | MATERIAL TESTING AGENCY                                      |
| 014545          | SPECIAL INSPECTION AGENCY AND OWNER TESTING AGENCIES         |
| 015050          | MOBILIZATION   |
| 015210          | TEMPORARY FACILITIES   |
| 015525          | TRAFFIC CONTROL  |
| 015719          | TEMPORARY ENVIRONMENTAL CONTROLS                             |
| 015810          | TEMPORARY SIGNS  |
| 016000          | PRODUCT REQUIREMENTS   |
| 016610          | STORAGE AND PROTECTION                                       |
| 017330          | CUTTING AND PATCHING   |
| 017419          | CONSTRUCTION WASTE MANAGEMENT AND DISPOSAL                   |
| 017420          | CLEANING   |
| 017515          | SYSTEM STARTUP, TESTING AND TRAINING                         |
| 017720          | CONTRACT CLOSEOUT  |
| 017825          | OPERATION AND MAINTENANCE DATA                               |



|        |                                    |
|--------|------------------------------------|
| 017835 | WARRANTIES AND BONDS               |
| 017840 | CONTRACT RECORD DOCUMENTS          |
| 017900 | DEMONSTRATION AND TRAINING         |
| 019113 | GENERAL COMMISSIONING REQUIREMENTS |

## SECTION 011100 - SUMMARY OF WORK

### PART 1 - GENERAL

#### 1.1 RELATED DOCUMENTS

- A. Drawings and general provisions of the Contract, including General and Special Conditions and other Division 01 Specification Sections, apply to this Section.

#### 1.2 SUMMARY AND DESCRIPTION

- A. The Work specified in this contract consists of furnishing all management, supervision, labor, materials, tools, equipment, services, testing and incidentals for the construction of the Work indicated in the contract documents including lump sum items and unit price items.
- B. The Work in this Contract may affect operations at DEN. The Contractor shall bid, plan and execute the Work to minimize disruption of operations and inconvenience to the public.
- C. Change Notice:
  - 1. The Contractor will be required to submit a proposal for each Change Notice
  - 2. The Contractor shall submit a proposal for the complete scope of the Work within the specified duration identified by the Notice. Where there is no time requirement identified by the notice documents, the Contractor shall submit a proposal within 20 days of receiving the notice or as allowed in Title 11 - Changes in the Work, Contract Price, or Contract Time of the General Contract Conditions, 2011 Edition.
  - 3. The proposal could contain both competitive bid and estimated costs and shall adhere to the requirements of Title 11 of the General Contract Conditions.
  - 4. The Contractor shall not proceed on any change notice work until a change order is issued.
- D. Change Directives:
  - 1. The DEN Project Manager may issue Change Directive(s) for a Scope of Work. The Contractor shall keep all Time and Material record for any Change Directive(s) issued until a final settlement for the task is settled and finalized in a Change Order.
  - 2. The Contractor shall keep records and approvals for all Time and Material impacts of a Change Directive until a final settlement is reached and fully executed by the DEN Project Manager.
  - 3. The Contractor may invoice for a Change Directive in accordance with Title 11 of the General Contract Conditions, 2011 Edition.
- E. Guaranteed Maximum Price (GMP): For Contracts assigned as GMP the Contractor

shall follow the Special Conditions issued for the Contract.

- F. This Project will be administered using the current Project Information Management System (PMIS). The application will be supplied by DEN at no cost to the Contractor. DEN will provide PMIS training for up to two (2) of the contractor's personnel.
- G. The Contractor shall participate in a preconstruction coordination meeting and update the existing BIM Project Execution Plan or prepare a BIM Project Execution Plan if one does not exist based upon the DEN BIM Project Execution Plan (BXP) template included as provided by the DEN BIM group and the coordination meeting instructions.
- H. DEN utilizes several programs as part of the Asset Management System. Keeping accurate as-built record and operation and maintenance data are essential in the integrity and the validity of the airport operation. The Contractor is required to make every effort to keep the airport data informed, updated and accurate in the format required by DEN Project Manager:
1. The Contractor shall provide and implement BIM Project Execution Plan based on the DEN BIM Project Execution Plan. The Contractor shall employ or contract a consultant to provide all the requirements to produce the Project model in the latest edition of the AutoCAD Civil 3D.
  2. The Contractor shall comply with all the requirements of DEN BIM Project Execution Plan and provide the data to DEN to produce the complete record of the BIM model of the Project
- I. Inspection Requirements:
1. Special Inspection and Testing required by the building official or the Engineer of Record in the Contract Documents or in the Statement of Special Inspections will be performed by DEN contracted Agencies.
  2. Contractor shall subcontract Qualified Material Testing Agency(s) to perform all necessary Quality Control, processing control and any additional Testing required by the Contract Documents.
  3. DEN Quality Assurance Manager may audit all material tests performed by the Contractor Quality Control at any time. Testing and Inspections for structural elements not identified as special inspection will be performed by the Contractor Quality Control Program and Contractor Material Testing Agency and audited and confirmed by DEN Quality Assurance Manager. DEN will perform 100% visual inspection on all weldments. DEN will perform Quality Assurance testing at a frequency of approximately 10% of the Quality Control test and inspection frequencies. The testing frequencies by DEN may escalate to higher percentages and the Contractor will be responsible for all costs associated with failing tests of the same pay item elements. The Contractor may not hire the DEN contracted or testing agency in any capacity on this Project.
- J. DEN Quality Assurance will perform all quality assurance pull and adhesion tests on all airfield joint sealants. Contractor shall perform all quality control tests for the same items.
- K. DEN Quality Assurance is required to submit a letter indicating that all Work performed

on the project complies with all applicable codes. The Contractor shall make sure that all required test frequencies and all deficiencies has been corrected to comply with all applicable codes standards and the requirements of the Contract Documents.

### 1.3 WORK BY OTHERS AND FUTURE WORK

- A. Refer to Title 7 – Cooperation, Coordination and Rate of Progress of the General Contract Conditions, 2011 Edition

### 1.4 SITE CONDITIONS

- A. Refer to Title 14 – Site Conditions of the General Contract Conditions, 2011 Edition

## **PART 2 - PRODUCTS (Not Used)**

## **PART 3 - EXECUTION**

### 3.1 CONTRACTOR'S DUTIES

- A. Refer to Title 3 – Contractor Performance and Services of the General Contract Conditions, 2011 Edition
- B. Execute the Work as specified and in a timely manner. Submit a schedule of Work that will be performed at times other than during the eight-hour working day of Monday through Friday, daylight hours. Submit this schedule five (5) working days prior to the beginning of Work to the DEN Project Manager for review and acceptance. Approval to work at night may be obtained after Contractor presents a written program outlining special precautions to be taken to control the extraordinary hazards presented by night work. That program shall include, but not limited to, supplementary lighting of work areas, availability of medical facilities, security precautions, and noise limitations.

### 3.2 COORDINATION

- A. Coordinate execution of the Work with those public utilities, governmental bodies, private utilities and other contractors performing work on and adjacent to the worksites. Eliminate or minimize delays in the Work and conflicts with those utilities, bodies, and contractors. Schedule governmental, private utility and public utility work that relies upon survey points, lines and grades established by the Contractor to occur immediately after those points, lines and grades have been established. Confirm coordination measures for each individual case with the DEN Project Manager in writing.
- B. In the coordination effort of work by others, the Contractor shall obtain and refer to equipment locations and other layouts, as available, to avoid interface problems.

- C. The City reserves the right to permit access to the site of the Work for the performance of work by other contractors and persons at such times that the City deems proper. The exercise of such reserved right shall in no way or to any extent relieve the Contractor from liability for loss and damage to the Work due to or resulting from its operations or from responsibility for complete execution of the Contract. The Contractor shall cooperate with other contractors and persons in all matters requiring common effort.

### 3.3 CONTRACTOR USE OF WORK SITE

- A. Confine work site operations to areas permitted by law, ordinances, permits, and the Contract.
- B. Consider the safety of the Work and that of the people and property on and adjacent to the work site when determining amount, location, movement, and use of materials and equipment on work site.
- C. Do not load work site with equipment and products that would interfere with the Work. Only equipment, tools, or materials required for this Work may be stored at the work site.
- D. Protect products, equipment, and materials stored on work site.
- E. Relocate stored products, equipment, and materials that interfere with operations of City, government bodies, public, and private utilities, and other contractors.

## PART 4 - MEASUREMENT

### 4.1 METHOD OF MEASUREMENT

- A. No separate measurement shall be made for work under this Section.

## PART 5 - PAYMENT

### 5.1 METHOD OF PAYMENT

- A. No separate payment will be made for work under this Section.
- END OF SECTION **011100**

## SECTION 011400 - WORK SEQUENCE AND CONSTRAINTS

### PART 1 - GENERAL

#### 1.1 RELATED DOCUMENTS

- A. Drawings and general provisions of the Contract, including General and Special Conditions and other Division 01 Specification Sections, apply to this Section.

#### 1.2 OTHER WORK

- A. Other concurrent construction contracts with which the Contractor must interface are described elsewhere in the Contract Documents. Refer to Section 013210 "Schedule" and the Special Conditions for specific work constraints and milestones.

#### 1.3 WORK SEQUENCE

- A. The work sequence shall comply with Phasing, Sequencing, and Milestones as indicated in the Contract Documents and in accordance with the approved Construction Schedule developed by the Contractor. The schedule shall comply with requirements indicated in the Special Conditions and Section 011400 "Work Sequence and Constraints". The Construction Schedule is described in Section 013210 "Schedule".

#### 1.4 WORK CONSTRAINTS

- A. Site Constraints:
  - 1. Access to the Project shall be generally as indicated in the Contract Documents. Access shall be organized and planned by the Contractor to ensure no disruption of airline or DEN operations.
  - 2. Access to work sites will be strictly monitored and must comply with DEN Airport Operations and FAA Regulations. The Contractor shall provide monitoring and escorts as required by DEN Operations in the area of the Work.
  - 3. The Contractor's staging area will be as indicated in the Construction Documents.
  - 4. Contractor employee parking will not be allowed within the existing revenue control system. Parking facilities will be as indicated in the Construction Documents.
  - 5. The Contractor shall use the haul routes specified in the Construction Documents.
  - 6. If required, the Contractor shall provide a bus and driver to transport the Contractor's employees between the designated employee parking area and the work sites. No separate payment will be made for this bus and driver. The cost shall be included in the bid item "Mobilization". The bus driver shall be provided

at all times when Contractor employees are working on the Project.

B. System Interruptions:

1. DEN is a 24/7/365 facility. Construction activity that requires any system shutdown must be coordinated with the project manager and DEN AIM MCC.
2. The Shutdown cannot proceed unless all approver groups have approved the request. If any of the groups rejects the request, you may not proceed with the Shutdown. If a Shutdown is determined to be an emergency due to pending health issues or the risk of additional damage, this process may be bypassed. If the Shutdown is an emergency, proceed with the shutdown without the approvals. Approvals must be obtained as follows
  - a. Airfield Shutdowns must be submitted at least 72 hours prior to the shutdown start date.
  - b. All other Shutdowns must be submitted at least five (5) business days prior to the shutdown start date.
  - c. All Shutdown Requests must be submitted using the Shutdown Request form, which can be accessed via the Home page of the DEN intranet.

C. Airfield Operations at Denver International Airport:

1. Full airport and aircraft operations are underway adjacent to this Project. Contractors are required to obtain a Contractor Participant Manual from the Security Manager and must follow the guidelines in the manual. Copies of the Contractor section of the manual are available for review at the Denver International Airport Access Services Office.
  - a. If any Work contains requirements for Work activities or access through or in the restricted area, reference Section 011420 "Security Requirements & Sensitive Security Information (SSI)" for requirements.
  - b. If not in a restricted area, the Contractor personnel still must be badged; reference Section 011420 "Security Requirements & Sensitive Security Information (SSI)".

D. Conduct of persons using the Denver Municipal Airport system:

1. Contractor activities shall comply with Airport Operations and Regulation 130 "TRAFFIC" and Regulation 20 "CONDUCT OF PERSONS USING THE DENVER MUNICIPAL AIRPORT SYSTEM" shall be followed at all times. These regulations are available from Airport Operations at Denver International Airport.

E. Operational safety on airports during construction:

1. All Work shall be accomplished in accordance with FAA Advisory Circular AC150/5370-2C, "Operational Safety on Airports during Construction", FAR Part 139 and FAR Part 107 except as herein modified.

F. Welding Equipment, Procedures and Constraints:

1. Natural gas-powered portable welders or inverter single- and three-phase electric portable welders are the only acceptable welding equipment to be used inside the building basement or tunnel areas. Acceptability of equipment other than the equipment noted above shall be at the sole discretion of the DEN Project Manager.
2. Welding activities inside buildings require submittal of a System Interruption Request (See paragraph "System Interruptions" above). Prior to welding in any area, the Contractor shall locate smoke detectors and shall request interruption of the fire alarm system. Subsequent to the interruption of the fire alarm system and prior to welding activities, the Contractor shall cover and protect smoke detectors until work is complete. Prior to expiration of each interruption of the system, the Contractor shall uncover the smoke detectors.
3. Electrical Service: The Contractor shall be responsible for verifying with the DEN Project Manager or representatives locations acceptable for accessing electrical power for welders and other electrical equipment feeders. The Contractor shall be responsible for all work and equipment required to install temporary or permanent electrical modifications for construction power and lighting.
  - a. Temporary Hook-up: In addition to the requirements of paragraph "Temporary Power and Lighting for Construction" below, comply with the following:
    - 1) Provide wiring sized to accommodate full load of welding equipment, accounting for voltage drop.
    - 2) Provide appropriate NEMA twist-lock or ANSI receptacle for welder hook-up.
    - 3) 480V, 3 phase, 3 pole, 4-wire twist lock ground line.
    - 4) NEMA L16-20 or ANSI C73.87.
  - b. The Contractor may not begin operation of the equipment prior to request for inspection by DEN representatives and acceptance of the installation.
  - c. Permanent installation of electrical branch circuiting for welding equipment shall be made in accordance with all Division 26 Specification Sections
4. Welding Practices: All standard safe welding practices must be followed, including but not limited to the following:
  - a. Flash protection for surrounding areas.
  - b. Contractor fire extinguisher in area.
  - c. One person in each welding area solely designated as fire watch for each welder.
  - d. Protect all equipment, cable trays and contents, etc., in area.
  - e. Use fire blankets and other appropriate materials to confine sparks and molten metal from the welding, cutting, and/or grinding activities.
  - f. All welders shall have been qualified through welding tests in accordance with applicable welding code, such as but not limited to AWS, ASME, API, within one year prior to welding taking place. Evidence of qualification shall be through Welding Performance Qualification Records (WPQR).
  - g. All welder qualifications test shall be or shall have been administered and witnessed by an Independent Testing Agency (ITA), AWS Certified Welding



Inspector (CWI).

- h. If recertification of welders is required, delay costs and retesting costs shall be borne by the Contractor.

5. Grounding: Review with DEN representative's area of work prior to beginning work to ensure ground procedures do not induce undesirable charges in steel building system or other systems. This review should take place subsequent to the pre-work meeting. Do not ground to adjacent building systems, baggage system, hangers, or devices that support mechanical or electrical equipment.

G. Temporary Power and Lighting for Construction:

1. The Contractor shall be responsible for all work and equipment required to install temporary or permanent electrical modifications for construction power and lighting.
2. The Contractor shall be responsible for all work and equipment required to install temporary or permanent electrical modifications for construction power and lighting.
  - a. Comply with all requirements of NEC Article 590.
  - b. Flexible cords used for temporary power shall be listed in accordance with NEC Article 400, and rated for 'extra-hard' usage.
  - c. Provide an equipment grounding conductor with all temporary power circuits.
  - d. All temporary power distribution devices and equipment shall be listed and rated for the application.
  - e. Provide ground fault protection for personnel.
  - f. Temporary lighting fixtures shall be protected from physical damage.

H. Cleaning Equipment and Spoils:

1. Discharge of water, liquids, or chemicals into a building sanitary sewer system or storm drainage systems is prohibited. The Contractor shall comply with all Federal, State, and Local requirements for disposal of chemicals and equipment wash water. The Contractor shall maintain and service all equipment in work areas and collect all wash water, spoils and water from excavations in containers for discharge or removal off site.

I. Vehicle Permitting for Tunnel and Basement Use:

1. Electric carts require permitting. The Contractor shall provide at least one (1) electric cart for Contractor use during the work in the tunnel and basements of the buildings. Only electric or CNG powered trucks are allowed in the tunnel and basements of the buildings. Only electric or CNG trucks may be used and shall not be parked overnight or for long terms within the tunnel or basements. All vehicles require permitting. Permits may be acquired at the DEN Airport Security Office.

J. Radio and Cell Phone Use:

1. The Contractor shall have wireless communications in place prior to initiation of work in the tunnel or basements by use of cell phone and/or radio. Radio and cell phone coverage in the tunnels and basements varies in signal strength throughout the campus. An RF Application must be submitted for the Radio equipment intended for use at least 14 days prior to intended use. Include the following radio information:
  - a. Make
  - b. Model
  - c. Frequency
  - d. Effective Radiated Power (ERP)
2. Contractors must receive an approval letter from the RF Systems Manager prior to use of the radio equipment on the DEN campus.

K. Keys:

1. The Contractor shall be required to contact DEN Maintenance Control to procure keys for access to all rooms having locks in order to gain access. Keys may be checked out at the beginning of each work shift by the Contractor and shall be returned to DEN Maintenance Control at the end of each work shift

## 1.5 COORDINATION

- A. The Contractor will designate a contact person for coordination with the DEN Project Manager and airline tenants. The contact person shall have the authority to make decisions for the Contractor firm and shall have binding signatory power for changes in work. The contact person shall be on site at all times during work activity.
- B. No additional costs shall be considered for coordination activities throughout this project. The Contractor shall include in the Contractor's bid costs for coordination of all activities.

## PART 2 - PRODUCTS (Not Used)

## PART 3 - EXECUTION

### 3.1 DUST/PROTECTION BARRIERS

- A. HVAC system containment. The Contractor shall submit to DEN Maintenance HVAC and Fire Alarm shutdown requests prior to modifications to the area of work for dust containment. The HVAC system shall be interrupted, re-routed, or blocked off to prevent dust from entering return or supply ducts.
- B. Debris and Protection Barriers:. The Contractor shall construct code-approved and DEN-approved dust and debris barriers on both sides of walls and doors that are to be modified. Barriers shall be constructed to allow emergency ingress and egress to and

from equipment and spaces. Barriers shall be constructed to allow continual uninterrupted function of building equipment and spaces.

1. Return all removed door hardware to DEN. Label each hardware set correlating the door number of the original hardware set. Coordinate with the DEN Project Manager for storage and return of hardware.

### 3.2 EQUIPMENT

- A. Equipment: CNG-powered equipment is allowed within the buildings. No other fossil fuel equipment may be used within the buildings unless the equipment is directly vented to the building exterior.
- B. Electric: Electric powered equipment is acceptable in the Work area.

## **PART 4 - MEASUREMENT**

### 4.1 METHOD OF MEASUREMENT

- A. No separate measurement shall be made for work under this Section.

## **PART 5 - PAYMENT**

### 5.1 METHOD OF PAYMENT

- A. No separate payment will be made for work under this Section.

END OF SECTION 011400

---

## **SECTION 011420 - SECURITY REQUIREMENTS & SENSITIVE SECURITY INFORMATION (SSI)**

### **PART 1 - GENERAL**

#### **1.1 RELATED DOCUMENTS**

- A. Drawings and general provisions of the Contract, including General and Special Conditions and other Division 01 Specification Sections, apply to this Section.

#### **1.2 DESCRIPTION**

- A. Each Contractor is required to become a "Participant" in the DEN Airport Security Program (ASP), and must remain in good standing in order to retain Airport Security privileges.
- B. All Contractor employees and all vehicles requiring access to the Secured Area, Sterile Area, and/or any other Controlled Areas shall be required to obtain the proper access authorizations for Airport ID badges and vehicle permits.

#### **1.3 PARTICIPANT OF AIRPORT SECURITY PROGRAM**

- A. Contractors are required to become a "Participant" of the ASP. In order to become a "Participant", your company must attend a Participant meeting within the Airport Security Office.
- B. The Contractor shall comply with all Denver Municipal Airport System Rules and Regulations and all Transportation Security Administration (TSA) regulations. Special emphasis should be paid to Denver Municipal Airport System Rules and Regulations Part 20 – Airport Security Rules and Regulations and Part 130 – Operating Vehicles In The Secured Area" and Part 35 – Operations Infraction Accountability Program". The Denver Municipal Airport System Rules and Regulations can be found on the [flydenver.com](http://flydenver.com) website.
- C. The TSA has the authority to issue civil penalties for failure to adhere to their regulations.
- D. It is the responsibility of the Airport Security Office to ensure all fences and gates are secure. If a Contractor's operations necessitate the frequent use of a particular gate, the Contractor shall place, at the Contractor's expense, two (2) contract security guards at the gate that shall have been trained and certified by the Airport Operations Division to facilitate access to its Work. The Contractor assumes full responsibility for maintaining security once this is done. If the perimeter gate will be used as a haul route, the contractor must also place, at the Contractor's expense, Haul Route Monitors as dictated by the TSA approved Temporary Amendment. Any fines levied

against the Airport as a result of the failure by the Contractor to provide adequate security shall be passed on to the Contractor.

1. If the Contractor provides guards or monitors, the Contractor must also supply a shelter for the guards/monitors. The shelter must meet the following requirements:

a. One 10 x 12 Tuff Shed or similar type structure with a window, 24-inch convex mirror mounted outside for vehicle inspection, sufficient HVAC capability, generator, light plant, and sanitary services, which are maintained by the Contractor.

E. Contractors will be required at all times to have a supervisor or foreman at each work location in Secured, Sterile, and Controlled Areas.

F. All Work shall be accomplished in accordance with the most current FAA Advisory Circular (AC) 150/5370-2, "Operational Safety on Airports during Construction", 49 Code of Federal Regulations (CFR) Part 1542 and 14 CFR Part 139 except as modified herein.

G. All Work shall be accomplished in accordance with the most current TSA Security Directives applicable to DEN, except as modified herein.

H. This Section intends to supplement, modify, change, delete from, or add to the most current FAA AC150/5370-2. Where any paragraph, subparagraph, or clause of the AC is modified or deleted by these supplements, the unaltered provisions of that paragraph, subparagraph, or clause shall remain in effect.

#### 1.4 SENSITIVE SECURITY INFORMATION (SSI)

A. If the Contract involves SSI information or procedures, the Contractor must contact the Assistant Director of Airport Security or designee, for disclosure information, as well as protocols that must be followed with SSI distribution.

B. This Section governs the maintenance, safeguarding, and disclosure of records and information that the TSA has determined to be SSI as defined by 49 CFR Part 1520, "Protection of Sensitive Security Information". SSI is information that the TSA has determined to be detrimental to the security of Denver International Airport if disclosed to unauthorized persons. This is a process for the documentation, use, and recovery of SSI of a specific origin.

C. Applicability:

1. For all management staff, all authorized departments, all contractors, and subcontractors handling documents or materials containing SSI information.

2. Each person employed by, contracted to, or acting on behalf of the Department of Aviation at Denver International Airport is subject to the requirements of this Section.

3. SSI disclosure is limited to persons or entities under criteria identified in federal

regulations, subject to strict “need-to-know” standard, and as otherwise determined by TSA or the Department of Homeland Security (DHS).

- D. Except as otherwise provided in this Section, records containing SSI are not available for public inspection or copying. Denver International Airport will not release such records to persons without a need to know. Prime contractors will not release SSI records to any subcontractor without a need to know. An employee or contractor has a “need to know” SSI if access to the information is necessary for performance of his or her official duties.
- E. Unauthorized disclosure of SSI is a Federal violation of 49 CFR Part 1520 and violation is grounds for a civil penalty and other enforcement action by DHS Security. In addition to the civil penalties, corrective action may include issuance of an order requiring retrieval of SSI to remedy unauthorized disclosure, an order to cease future unauthorized disclosure, and dismissal from the work site.
- F. Except as otherwise provided in writing by the TSA in the interest of public safety or airport security, the following information and records containing such information constitute SSI:
1. Information that would be detrimental to the security of Denver International Airport and aviation transportation.
  2. Any performance specification, including a description of devices and procedures used by Denver International Airport, for the detection of any weapon, explosive, incendiary, or destructive substance.
  3. Any performance specification, including a description of devices and procedures, for any communications equipment used by Denver International Airport in carrying out any aviation transportation security requirements.
  4. Details of any security inspection or investigation of an alleged violation of aviation transportation security requirements of Federal law that could reveal security vulnerability.
  5. Specific details of aviation transportation security measures including those recommended by the Federal government.
  6. The following information regarding security screening under aviation transportation security requirements of Federal law:
    - a. Procedures for screening of persons, property, checked baggage, U.S. mail, and cargo.
    - b. Information used by a passenger or property-screening program or system, including an automated screening system.
    - c. Detailed information, if determined by the TSA to be SSI, about the locations at which particular screening methods or equipment are used.
    - d. Performance or test data from security equipment or screening systems.
  7. Identifying information of certain aviation transportation security personnel including lists of the names or other identifying information that identify persons as having unescorted access to a secure area of the airport.
  8. Critical aviation asset information identifying systems so vital to the airport that the incapacity or destruction of such assets would have a debilitating impact on

- aviation security.
9. Any information involving the security of operational or administrative data systems identified by the Department of Transportation or DHS as critical to the safety or security of Denver International Airport.
  10. Solicited or unsolicited proposals, pursuant to a grant or contract, to perform work that relates to security measures.
- G. Restrictions on the Disclosure of SSI:
1. Employees and contractors working onsite have a duty to protect sensitive security information and must take reasonable steps to safeguard SSI in that person's possession from unauthorized disclosure. When a person is not in physical possession of SSI, the person must store it in a secure container such as a locked desk, a locked file cabinet, or in a locked room. SSI is to be disclosed only to persons having a need to know as stated in CFR 1520. Requests for SSI are to be referred to City Project Manager.
  2. Prior to receiving SSI records, contractors must sign the "Confidentiality and Non-Disclosure Agreement", Form PS-17, stating that SSI will be guarded from unauthorized persons, that records will be controlled while in use and secured when not in use, and that all SSI plans and records will be returned to the airport or destroyed following the completion of the Project.
  3. Return or destruction of SSI documents must be done in a timely manner and documented on the SSI Return or Destruction Compliance Form, Form PS-20. Companies under contract to the City must return or destroy all SSI material following the completion of the Work. Companies not selected during the bidding process must return or destroy all SSI material immediately following the announcement of bid results.
- H. If a record containing SSI is received that is not marked as specified in this Section below, the following steps must be taken:
1. Mark the record as specified in paragraph Part 1 of this Section.
  2. Inform the sender of the record that the record must be marked as specified in Part 1 of this Section.
- I. If a person becomes aware that SSI has been released to unauthorized persons, promptly inform the Communication Center Supervisor at 303-342-4020 and request to speak to the on-call Airport Security Coordinator
- J. Marking SSI:
1. In the case of paper records containing SSI, a covered person must mark the record by placing the PROTECTIVE MARKING conspicuously on the top, and the DISTRIBUTION LIMITATION STATEMENT on the bottom, of following parts of the document:
    - a. The outside of any front and back cover, including a binder cover or folder, if the document has a front and back cover.
    - b. Any title page
    - c. Each page of the document

2. Protective Marking:
  - a. SENSITIVE SECURITY INFORMATION
  - b. Distribution Limitation Statement:
  - c. WARNING: This record contains Sensitive Security Information that is controlled under 49 CFR parts 15 and 1520. No part of this record may be disclosed to persons without a "need to know", as defined in 49 CFR parts 15 and 1520, except with the written permission of the Administrator of the Transportation Security Administration or the Secretary of Transportation. Unauthorized release may result in civil penalty or other action. For U.S. government agencies, public disclosure is governed by 5 U.S.C. 552 and 49 CFR parts 15 and 1520
3. In the case of non-paper records that contain SSI, including motion picture films, videotape recordings, audio recording, and electronic and magnetic records, a covered person must clearly and conspicuously mark the records with the protective marking and the distribution limitation statement such that the viewer or listener is reasonably likely to see or hear them when obtaining access to the contents of the record.

K. Destruction of SSI:

1. When the employee or contractor no longer needs the SSI to carry out their work requirements, the SSI must be returned to the issuing entity or completely destroyed by burning or cross-shredding to preclude recognition or reconstruction of the information.
2. The Contractor shall comply with all the requirements of the Department of Aviation Standards and Procedures, Protection of Sensitive Security Information (SSI) No. 10003 Revised 08/01/15 regarding Contractor Protection of Sensitive Security Information (SSI).

1.5 MISCELLANEOUS

A. Dumpster Security Requirements:

1. The following procedures must be followed to provide maximum security with all construction projects in public areas unless an exception has been made by the Airport Security Coordinator (ASC) or designee:
  - a. Roll-off dumpsters must have the ability to be covered (hard side) and locked when not in use.
  - b. When unlocked and in use, the Contractor shall provide an employee, or a subcontractor's employee, to stand by the dumpster to prevent unauthorized placement of prohibited items
2. If the Contractor is not able to have a roll-off dumpster with the ability to be locked, the dumpster shall be removed from the public area when the construction site is inactive.



B. Contractor Fences (Not Perimeter Fence):

1. If required, the Contractor shall establish and maintain a secure (fenced) perimeter at its primary operations area to include its field offices, staging and storage areas, and maintenance facilities. The responsibility for security within its operations area shall rest solely with the Contractor. Entrance gates to operations areas shall be equipped with a combination of locks to include a lock provided by the City for its use in accessing emergency equipment, should that need arise. The location, size and other physical characteristics of the Contractor's operations area must be approved by the DEN Project Manager prior to its installation.
2. Unless specifically required by the Contract Documents and with the exception of the fenced operations area described above, the Contractor shall install no fences or other physical obstructions on or around the Project work area without the written approval of the DEN Project Manager.

**PART 2 - PRODUCTS (Not Used)**

**PART 3 - EXECUTION**

3.1 SUBMITTAL FOR AIRPORT ID BADGES

- A. By submitting information for the individual requesting or requiring an Airport ID badge that would permit unescorted access to the Sterile and/or Secured Areas must be fingerprinted and pass a Criminal History Records Check (CHRC) and Security Threat Assessment (STA). Passing a CHRC means the employee shall not have been convicted, given a deferred sentence, found not guilty by reason of insanity or have been arrested and are awaiting judicial proceedings of any felony charge during the ten (10) years before the date of the individual's application for unescorted access authority. For an individual to obtain driver authorization to drive within the Secured Area, the individual must have a valid driver license that allows them to drive their contractor vehicle.
- B. An employee requesting an Airport ID badge must resolve all pending or valid violations before being allowed to proceed in the airport ID badging process. If the employee no longer works for the company and is attempting to be employed by a different company, a management representative from the "new" company must attend the Violation Notice Hearing along with the employee.
- C. Airport ID Badges are obtained as follows:
  1. The Contractor shall meet with the City Project Manager to review the procedures and required access points at DEN. The Contractor and the DEN Project Manager shall visit the site to verify the access points. Access points shall be listed and submitted by the Contractor to the DEN Project Manager for review and comment prior to Contractor's application for badging.
  2. The Contractor shall designate an Authorized Signatory who must attend an

- annual class with Airport Security. The Authorized Signatory must be an employee of the Contractor, have a valid Denver International Airport ID badge. The Authorized Signatory will be authorized to sign for the Contractor on the Fingerprinting and Badge Application Form and will be the primary designation contact for Airport Security related business.
3. The Contractor's Authorized Signatory shall schedule a Participant Meeting with the DEN Airport Security Office to review DEN security procedures and receive training on how to ensure that all Participants remain in compliance with Part 20 of the Denver Municipal Airport System Rules and Regulations. A second meeting will be scheduled for the Authorized Signatory to learn how to successfully complete the required forms for Airport ID badges and vehicle permits.
  4. A CHRC and STA are required for each employee requesting unescorted access to the Secure and/or Sterile Area. The employee will complete the Fingerprinting and Badge Application (two-sided form) and schedule an appointment with the Airport Security Office to have the form reviewed and to be fingerprinted. The Federal Bureau of Investigation will conduct the CHRC and will return the results to the Airport Security Office. For the fee for the Fingerprinting, please see the flydenver.com website. The Transportation Security Administration will process the STA and will return the results to the Airport Security Office.
  5. When the Authorized Signatory is notified by Airport Security that the CHRC and STA have cleared, the applicants must come to the Airport Security Office to receive regulated security and driver training. The training will take approximately one (1) hour for security training and approximately two (2) hours for security and driver training.
  6. All applicants must watch and pass all concepts of a computer based security training module for a Security Identification Display Area (SIDA) Airport ID badge. All individuals requesting driver authorization in the non-movement area must also view an interactive computer based driver training module and complete a test by passing all concepts. In addition, the individual must receive non-movement driver orientation training by the Contractor's driver representative before being allowed to drive on the airfield. Non Movement Orientation training should be conducted annually.
  7. All Airport ID badges must be immediately terminated upon employee separation from the Contractor or when a need for DEN access no longer exists.
  8. The Airport ID badges must be returned to the Airport Security Office prior to final payment. All Airport ID badges are issued with an annual expiration date. The expiration date is determined by the birthday of the Airport ID badge holder. Contractors shall notify the DEN Project Manager as soon as possible but in no case less than four (4) weeks in advance of any requirement to extend the Sponsorship status.

## **PART 4 - MEASUREMENT**

### **4.1 METHOD OF MEASUREMENT**

- A. No separate measurement shall be made for work under this Section.

## **PART 5 - PAYMENT**

### 5.1 METHOD OF PAYMENT

- A. No separate payment will be made for work under this Section.

END OF SECTION **011420**

## SECTION 011430 - VEHICLE AND EQUIPMENT PERMITTING

### PART 1 - GENERAL

#### 1.1 RELATED DOCUMENTS

- A. Drawings and general provisions of the Contract, including General and Special Conditions and other Division 01 Specification Sections, apply to this Section.

#### 1.2 SUMMARY

- A. The Contractor shall comply with the Airport Security Program. Vehicle permits are required for all vehicles operating in the Secured Area. The DEN vehicle permit is required for vehicles operating in the Secured Area but limited to above grade, outdoor activity. Vehicles or machinery operating within buildings shall be required to acquire a DEN emissions permit as well as a DEN vehicle permit.
- B. Special emphasis should be paid to Denver Municipal Airport System Rules and Regulations Part 20 – Airport Security Rules and Regulations and Part 130 – Operating Vehicles In The Secured Area" and Part 35 – Operations Infraction Accountability Program". The Denver Municipal Airport System Rules and Regulations can be found on the flydenver.com website.
  - 1. All Work shall be accomplished in accordance with the most current FAA Advisory Circular (AC) 150/5370-2, "Operational Safety on Airports during Construction", 49 Code of Federal Regulations (CFR) Part 1542 and 14 CFR Part 139 except as modified herein.
  - 2. All Work shall be accomplished in accordance with the most current TSA Security Directives applicable to DEN, except as modified herein.
  - 3. Access to the runways, taxiways, and aprons shall be gained by the Contractor after establishing radio communications with Airport Operations through the DEN Inspector. No personnel or equipment will be allowed on the runways until radio contact has been made with Airport Operations and permission given.
  - 4. Access to the Movement Area will be limited in order to allow the maximum efficient movement of aircraft. As part of this limitation, the Contractor may be required to only use these areas late at night when there is less aircraft traffic
  - 5. Once admitted into the Secured Area, the Contractor shall proceed directly to the work location by way of a route assigned by Airport Security. At no time shall a Contractor or any of its personnel enter onto a taxiway, runway, or ramp without proper clearance from the Airport Operations Manager or Assistant Airport Operations Manager. Contractors or individuals violating these requirements for driving in the Secured Area may be subject to fines, suspension, or permanent revocation of their driver authorization and/or Airport ID badge privileges.
  - 6. The Transportation Security Administration (TSA) requires that all operating airports be secured from the general public and has the authority to issue citations for violations of these requirements. It is the responsibility of the Airport

to ensure all fences and gates are secure. If a Contractor's operations necessitate the frequent use of a particular gate, the Contractor shall place guards at the gate. Refer to 011420 – Security Requirements and SSI for details regarding the placement of guards.

C. General Safety Regulations When in Aircraft Operations Areas May Include the Following:

1. At all times, the Contractor shall coordinate its Work with the requirements of the Airport site and operations. All Work, movement of personnel, materials, supplies and equipment in areas used by aircraft shall be subject to regulations and restrictions established by the City. The Contractor shall take special precautions and be fully responsible for the prevention of damage to materials and equipment in the areas affected by the jet blast of taxiing aircraft. No work shall proceed until necessary protective devices are placed as required to protect the public, airport operations, property, and personnel from the hazards of the Work. The Contractor shall proceed with the Contractor's Work, including temporary work and storage of tools, machinery, and materials, to cause no interference with or hazards to the operation of the Airport.
2. Landings, takeoffs, and taxiing shall take precedence over all Contractors' operations. In the event that the Contractor is notified that an emergency landing or a takeoff is imminent, the Contractor shall stop all operations immediately, regardless of the sequence of events in progress and shall immediately evacuate the Contractor's personnel and equipment from the runway and taxiway areas as directed.
3. The Contractor shall remove its personnel and equipment to the distance specified below for the prevailing conditions:
  - a. For emergencies, the Contractor shall move all personnel and equipment as directed by Airport Operations or the DEN Project Manager.
  - b. At the end of a work day in areas where aircraft are operating, all equipment shall be moved to a location that is not less than 750 lineal feet measured from the near edge of the runway, taxiway or ramp area or to the location designated by the City.
4. If the Contractor is asked to leave part of its work site to allow aircraft operation, the Contractor shall clean the area to allow safe aircraft movement. Cleaning may include sweeping the area to prevent damage to aircraft.

D. Vehicle Permitting:

1. Refer to the Denver Municipal Airport System Rules and Regulations Part 20 – Airport Security Rules and Regulations and Part 130 – Operating Vehicles In The Secured Area" and Part 35 – Operations Infraction Accountability Program" for information regarding vehicle permitting. These Denver Municipal Airport System Rules and Regulations can be found on the flydenver.com website.
2. For additional information regarding permitting, the Contractor must contact DEN Security.

E. Equipment Permitting

1. Fossil fuel powered equipment to be used in the interior of buildings and/or in basement/tunnel areas shall require inspection by DEN Maintenance and the Denver Fire Department.
  - a. Only CNG fossil fuel powered equipment may be used; gasoline powered, propane powered, or diesel powered equipment will not be acceptable unless identified and operated per Section 011400 "Work Sequence and Constraints".

## **PART 2 - PRODUCTS (Not Used)**

## **PART 3 - EXECUTION**

### **3.1 PERMITS**

- A. Vehicle permits shall not be issued prior to Notice to Proceed. The Contractor may, at the Contractor's own risk, submit required information prior to Notice to Proceed to the following:
  1. Vehicle permit: DEN Engineering Group or DEN Airport Security.
  2. Equipment and vehicle emissions permit. DEN Engineering or DEN Maintenance Group.

### **3.2 SCHEDULE**

- A. The Contractor shall allow in the Contractor's schedule five (5) days for DEN review of submittals for permits. Testing of equipment and review by the Denver Fire Department shall be scheduled by the Contractor. By submitting information for permits, the Contractor certifies that equipment and vehicles comply with Contract documents and with all City, state and federal regulations including but not limited to emissions, licensing and safety requirements.

## **PART 4 - MEASUREMENT**

### **4.1 METHOD OF MEASUREMENT**

- A. No separate measurement shall be made for work under this Section.

## **PART 5 - PAYMENT**

### **5.1 METHOD OF PAYMENT**

- A. No separate payment will be made for work under this Section.

END OF SECTION **011430**

## SECTION 011810 - UTILITIES INTERFACE

### PART 1 - GENERAL

#### 1.1 RELATED DOCUMENTS

- A. Drawings and general provisions of the Contract, including General and Special Conditions and other Division 01 Specification Sections, apply to this Section.

#### 1.2 SUMMARY

- A. Various utilities are located within the limits of work in the Project area. The owners of these utilities hereinafter noted may require that the Contractor is to work around their existing facilities until such alterations, relocation, or abandonment have been completed. All known existing utilities are shown; however, the Contractor shall verify and satisfy himself that there are no other existing utilities that may not be shown.
- B. The owners of known utilities within the project area and corresponding representatives include, but are not limited to:
  - 1. Century Link Telephone
  - 2. DEN Telephone
  - 3. Xcel Energy Natural Gas
  - 4. Xcel Energy Elec. Services
  - 5. DEN Storm Water
  - 6. DEN Sanitary Sewer
  - 7. Denver Water Department
  - 8. Inland Technologies
  - 9. Fuel System (ASI)
  - 10. Premise Wiring System- DEN IT Section
  - 11. FAA Duct Bank
  - 12. Oil/Gas Wells
  - 13. DEN Electrical Department
  - 14. Fire Alarm System
  - 15. Paging System
- C. The location and establishment of each construction vehicle crossing shall be at sites mutually agreed upon in writing by the Contractor and the owner of the utility.
- D. At the locations where the Contractor needs to establish a construction vehicle crossing over any of the operating pipelines, the furnishing and placing of a crossing shall be by the Contractor. The crossing shall allow the normal operation of the pipeline at all times. Each crossing shall be adequately marked and signed for safe passage of vehicles over the crossing. Construction vehicles shall not be allowed to cross over operating pipelines at any place other than an established crossing.
- E. These utility locations are based upon information provided by the utility companies or



previous construction contractors that were the basis for determining utility coordinates. The Contractor is responsible for confirming the accuracy of the provided coordinates.

- F. The Contractor shall control the Contractor's operations in order to avoid creating any obstacles for the utility owner's access for maintaining or operating their equipment.

### 1.3 REFERENCE DOCUMENTS

- A. Section 312323.33 "Flowable Backfill (Controlled Low-Strength Material)"

### 1.4 REGULATORY REQUIREMENTS

- A. The Contractor shall obtain and pay for all utility company permits, fees, and licenses necessary for the execution of this work. The Contractor shall give all notices and shall comply with all laws, ordinances, rules, and regulations of all authorities having jurisdiction.

### 1.5 QUALITY CONTROL

- A. When the Contractor performs any operations that will affect a utility owner, the Contractor shall give timely notice to the utility owner and the DEN Project Manager so that the Contractor's operations may be observed by the utility owner or their representative.

### 1.6 WORK INCLUDED

- A. The Work of this Section includes furnishing all materials, equipment, and labor necessary to provide utility crossings as required and as specified herein and subject to approval by the associated utility owner.
- B. North American Resources has a line passing through airport property. The Contractor shall contact the utility prior to beginning earthwork operations to ascertain any special requirements or conditions required to maintain and protect this service during construction activities.
- C. FAA Underground Duct lines: The FAA has duct lines passing under the site. The Contractor shall contact the FAA prior to beginning earthwork operations to ascertain any special requirements or conditions required to maintain this service during construction activities.

---

## **PART 2 - PRODUCTS**

### **2.1 MATERIALS**

- A. Suitable cover material shall be in accordance with Colorado Department of Transportation Standard Specifications. Wet, soft, or frozen material, asphalt chunks, or other deleterious substances shall not be used for cover.
- B. Aggregate for road base material shall consist of clean, sound and durable particles of crushed stone, crushed gravel or crushed slag, shall be free from coatings of clay, silt and organic matter, and shall contain no clay balls. Material shall conform to the State of Colorado Standard Specifications for Road and Bridge Construction Class 6 aggregate base unless otherwise specified.
- C. The materials for the load distribution system on top of the cover shall conform to the specification of the American Institute of Steel Construction, the American Institute of Timber Construction, or the American Concrete Institute, as applicable, depending upon the system agreed upon between the Contractor and utility owner.
- D. Materials for the sleeving of the pipelines shall be purchased by the utility owner at the Contractor's expense.
- E. Comply with utility backfill requirements for the use of flowable backfill in Section 312323.33 "Flowable Backfill (Controlled Low-Strength Material)" and Division 26 and Division 33 requirements.

## **PART 3 - EXECUTION**

### **3.1 NOTIFICATION OF UTILITIES FOR LOCATING AND POTHOLING**

- A. The Contractor shall verify the location of all utilities prior to any operations including physically uncovering the utility to verify location as required by the utility owner.
- B. The Contractor shall notify the Utility Notification Center of Colorado at (303) 534-6700 or 811, as a minimum for location of utilities.

## **PART 4 - MEASUREMENT**

### **4.1 METHOD OF MEASUREMENT**

- A. No separate measurement shall be made for work under this Section.

## **PART 5 - PAYMENT**

### 5.1 METHOD OF PAYMENT

- A. No separate payment will be made for work under this Section.

END OF SECTION **011810**

## **SECTION 012510 - SUBSTITUTIONS**

### **PART 1 - GENERAL**

#### **1.1 RELATED DOCUMENTS**

- A. Drawings and general provisions of the Contract, including General and Special Conditions and other Division 01 Specification Sections, apply to this Section.

#### **1.2 SUMMARY**

- A. All material and equipment substitutions must comply with Title 4, Article 406: Substitution of Materials and Equipment in the General Contract Conditions, 2011 Edition.
- B. The Work specified in this Section consists of submitting form CM-09, Request for Substitution for the approval of a different material, equipment, or process than is described in the Contract Documents.
- C. If the substitution changes the Scope of Work, Contract cost, or Contract time, a Change Order is required.
- D. As-built drawings and specifications must include all substitutions even if a Change Order is not issued.

#### **1.3 REFERENCE DOCUMENTS**

- A. Form CM-09, Request for Substitution
- B. Section 013300 "Submittal Procedures"
- C. Section 013325 "Shop and Working Drawings, Product Data and Samples"

#### **1.4 QUALITY CONTROL**

- 1. The substitution shall provide as a minimum, the same performance as specified.

#### **1.5 SUBMITTALS**

- A. Refer to Section 013300 "Submittal Procedures" and Section 013325 "Shop and Working Drawings, Product Data and Samples" for submittal procedures.
- B. A completed Form CM-09 shall be submitted at least 60 days prior to when an order needs to be placed or a method needs to be changed.

- C. The submittal shall contain all the data required to be submitted for acceptance of the originally specified item or process, including, as appropriate:
1. Detailed product data sheets for the specified items and the substitution.
  2. Samples and shop drawings of the substitution.

## **PART 2 - PRODUCTS (Not Used)**

## **PART 3 - EXECUTION**

### **3.1 SUBSTITUTION PROCESS**

- A. Provide the information as required on Form CM-09.

### **3.2 SUBSTITUTION REQUEST**

- A. The formal Request for Substitution will be evaluated by the DEN Project Manager and the Designer of Record based on the following criteria:
1. Compatibility with the rest of the project.
  2. Reliability, ease of use and maintenance.
  3. Both initial and long term cost.
  4. Schedule impact.
  5. The willingness of the Contractor to share equally in any cost savings.
  6. The ability of the item or process to meet all applicable governing regulations, rules, and laws along with funding agency requirements.
  7. The cost of evaluating the substitution.
- B. Based upon the above evaluation, the Sr. Director of AIM Development will make a final determination of what is in the best interest of the City and either approve, disapprove or approve as noted the requested substitution.

### **3.3 CONDITIONS**

- A. As a condition for submitting a Request for Substitution the Contractor waives all rights to claim for extra cost or change in Contract time other than those outlined in the request and approved by the Deputy Manager of Aviation. The Contractor, by submitting a Request for Substitution, also accepts all liability for cost and scheduling impact on other contractors or the City due to the substitution.
- B. Included with the Request for Substitution shall be the following statement:
1. "The substitution being submitted is equal to or superior in all respects to the Contract-required item or process. All differences between the substitution and the Contract-required item or process are described in this request along with all required information, cost, and scheduling data."

- C. The statement shall be signed and dated by the Contractor's Superintendent.
- D. Replacement of Substitution Found to be Not Equal:. The Contractor shall be responsible for all aspects and conditions of the substitution that are not clearly identified in the substitution submittal, and shall be liable for the appearance, function, performance or other aspects of the substitution that are found not to be equal to the originally specified item.
  - 1. The Contractor shall incur all labor and costs associated with replacement of any substitution that is found to be not equal to the originally specified item or process and rejected by the DEN Project Manager.
  - 2. The replacement of any rejected substitution shall either be with the originally specified item or process, or a substitution approved by the DEN Project Manager

#### **PART 4 - MEASUREMENT**

##### 4.1 METHOD OF MEASUREMENT

- A. No separate measurement shall be made for work under this Section.

#### **PART 5 - PAYMENT**

##### 5.1 METHOD OF PAYMENT

- A. No separate payment will be made for work under this Section.

END OF SECTION **012510**



## **SECTION 012910 - SCHEDULE OF VALUES**

### **PART 1 - GENERAL**

#### **1.1 RELATED DOCUMENTS**

- A. Drawings and general provisions of the Contract, including General and Special Conditions other Division 01 Specification Sections, and Related Requirements apply to this Section.

#### **1.2 RELATED REQUIREMENTS**

- A. The Work specified in this Section consists of preparing and submitting the Schedule of Values ("Schedule") as referenced in the General Conditions. Use the Project Specifications Table of Contents or Bid Tabs, if applicable, as a guide to establish line items for the Schedule of Values. Provide at least one line item for each Specification Section. The Work also includes the preparing and submitting of updated copies of the Schedule if the Schedule is affected by change orders.
- B. A Schedule of Stored Material is a detailed cost breakdown for permanent materials that will be temporarily stored prior to their being installed and for which the Contractor seeks partial payments. The Schedule of Stored Material will be incorporated as a part of the Schedule of Values.
- C. Within 14 calendar days of issuance of the Notice to Proceed (NTP), the Contractor shall submit the Schedule of Values including the Schedule of Stored Material if applicable. The Schedule of Values and Schedule of Stored Material used to prepare the work/cost breakdown for the Schedule will be used for the Contractor's billings.
- D. Any Contract allowances shall be included in the Schedule. Expenditure of allowances shall be done using the Allowance Authorization form. Use of this form does not increase or decrease the Contract value.

#### **1.3 RELATED DOCUMENTS**

- A. Title 9 – Compensation of the General Contract Conditions, 2011 Edition
- B. Section 013300 "Submittal Procedures"
- C. Section 013325 "Shop and Working Drawings, Product Data and Samples".
- D. Form CM-89, Schedule of Values
- E. Form CM-91, Schedule of Values for Unit Price Contracts



#### 1.4 SUBMITTALS

- A. The Schedule of Values shall be formally approved by the DEN Project Manager.
- B. The Schedule shall identify each item of work. Work items in the Schedule shall represent all Work and shall be referenced with the Technical Specifications section numbers, specification subparagraph, specification section title and the bid item number used for the Schedule of Prices and Quantities when applicable.
- C. Upon request by the City, the Contractor shall support values given with the data that will substantiate the correctness of the values.
- D. The Schedule will be utilized only as a basis for review of the Contractor's application for progress payment.

#### 1.5 REVIEW AND RESUBMITTAL

- A. If review by the DEN Project Manager indicates that changes to the Schedule are required, the Contractor shall revise and resubmit the Schedule.

### **PART 2 - PRODUCTS (Not Used)**

### **PART 3 - EXECUTION**

#### 3.1 PREPARING SCHEDULE OF VALUES

- A. Provide a breakdown of the Contract Price in enough detail to facilitate continued evaluation of Applications for Payment and progress reports.
- B. Breakdown of the items used in the Schedule shall include the following item costs. Ensure each item is complete:
  - 1. Delivered cost of product with applicable taxes paid.
  - 2. Total installation cost with overhead and profit.
  - 3. Breakdown costs of each lump sum item with a list of products and major operations for which the Contractor seeks to receive progress payments to recover the Contractor's costs for that bid Item.
  - 4. Each unit price item as listed in the bid Schedule of Prices and Quantities shall list products and major operations for which the Contractor seeks to receive progress payments for that bid item.

#### 3.2 PREPARING SCHEDULE OF STORED MATERIAL

- A. The Contractor shall submit with the Schedule an indication of whether products will be stored on or off the work site. The Schedule of Stored Material shall show all quantities and types of products that will be stored.

- B. Material allowances consist of only the net cost of the product, the cost of delivery and unloading at the storage site, the cost of applicable sales taxes, and all discounts.
- C. In no case will the cost paid for a permanent material be greater than 90 percent of the Contract price for the Work in which they are included.

### 3.3 PAYMENT FOR STORED MATERIALS

- A. Only materials that are described in the specifications and on the drawings will be considered permanent materials. Permanent materials are materials that will be left in the Work after the Contract is completed.
- B. Nothing in these specifications shall be interpreted as requiring the City to pay for stored materials. The DEN Project Manager shall decide on a case-by-case basis whether stored materials shall be paid for. No payment will be made for stored materials that have not been submitted and accepted.
- C. The Contractor must, at all times, store permanent materials in accordance with manufacturer's recommendations. Any material not properly stored will not be paid for. Amounts will be deducted from payments for any stored permanent material previously paid for and subsequently found to be improperly stored or not present, based upon a physical inventory of stored permanent material.
- D. Only the neat line quantity of material needed for the finished product may be paid for.
- E. All requests for stored permanent material payment must be accompanied by paid invoices clearly showing the quantity of permanent material, the type of permanent material and discounts or rebates and the net amount paid to the supplier along with a certificate stating that the permanent material is free of any liens or judgments preventing its use by the City.
- F. If the permanent material is stored outside the Denver area the Contractor must pay for the City representative's transportation and lodging to see the stored material as needed. Acceptable lodgings must, as a minimum, have a Mobil Travel Guide Rating Criteria® rating of Two-Star or the American Automobile Association Lodging Listing Requirements & Diamond Rating Guidelines® rating of Two Diamonds. The minimum transportation shall be by regularly scheduled commercial air carrier at coach rates. The DEN Project Manager will determine if an overnight stay is required.
- G. All permanent material stored off site, for which payment is being requested, must be insured and stored in bonded, insured warehouses. The Contractor shall provide proof of insurance for all material stored off site, and specific address and storage conditions of storage location.
- H. Any permanent material on which payment is requested must be in such a form that it cannot be used on work other than this Contract, or stored in a manner acceptable to the DEN Project Manager to ensure that the permanent material cannot be used on work other than this Contract.

3.4 ALLOWANCE AUTHORIZATION AND PAYMENT

- A. Contractor shall request written approval for expenditure of any Contract allowances PRIOR TO performing the Work involved. List work to be performed and estimated cost in the requesting correspondence.
- B. Original copies of all invoices and receipts must be submitted with the Allowance Authorization as part of the request for payment.
- C. Using the format provided by the City, the Contractor's request for payment of all Contract allowances shall be included in the Schedule of Values.

**PART 4 - MEASUREMENT**

4.1 METHOD OF MEASUREMENT

- A. No separate measurement shall be made for work under this Section.

**PART 5 - PAYMENT**

5.1 METHOD OF PAYMENT

- A. No separate payment will be made for work under this Section.

END OF SECTION **012910**

## SECTION 013100 - PROJECT MANAGEMENT AND COORDINATION

### PART 1 - GENERAL

#### 1.1 RELATED DOCUMENTS

- A. Drawings and general provisions of the Contract, including General and Special Conditions and other Division 01 Specification Sections, apply to this Section.

#### 1.2 SUMMARY

- A. Section includes administrative provisions for coordinating construction operations and coordination with other stakeholders and adjacent Contractors on the Project including,

1. Subcontractor's Acceptance Certification and Subcontractors List.
2. General Coordination Procedures.
3. Contract Administration Procedures.
4. Current Project Management Information Systems (PMIS)
5. Coordination drawings.
6. Current DEN Asset Management Systems
7. Requests for Information (RFIs).

- B. Related Requirements:

1. Section 011100, " Summary of Work" for a description of the division of work among separate contracts and responsibility for coordination activities not in this Section.
2. Section 011400 "Work Sequence and Constraints" for shutdown requests and coordinating with airport operational activities.
3. Section 011420 "Security Requirements and Sensitive Security Information (SSI)".
4. Section 013210 "Schedule" for preparing and submitting Contractor's Construction Schedule.
5. Section 013223 "Construction Layout, As-built and Quantity Surveys" for coordinating, survey activities and survey related record documents.
6. Section 013300 "Submittal Procedures. "
7. Section 013325 "Shop and Working Drawings, Product Data and Samples".
8. Section 017720 "Contract Closeout" for coordinating closeout of the Contract.
9. Section 017419 "Construction Waste Management and Recycling".
10. DEN Building Information Modeling (BIM) Design Standards Manual (DSM)

#### 1.3 DEFINITIONS

- A. RFI: Request from the DEN Contractor DEN Project Manager seeking information required by or clarifications of the Contract Documents.

1.4 SUBMITTALS - SUBCONTRACTORS ACCEPTANCE CERTIFICATION AND SUBCONTRACTORS LIST

- A. To comply with Section 502.2 in the General Contract Conditions, 2011 Edition, the Contractor must complete and submit form CM-02 Subcontractor Acceptance Certification for each Subcontractor working on the project. Additionally, the Contractor must prepare a written summary identifying individuals or firms proposed for each portion of the Work, including those who are to furnish products or equipment fabricated to a special design.
- B. Provide emergency contacts list to the DEN Project Manager prior to any site activities. List must contain project name, number, location, company name and address, name and title of emergency contacts in order and time and assigned responsibilities. Keep list current and accurate at all times. Include any specific security arrangements or special projects requirements.
- C. Within two (2) days of Notice to Proceed, the Contractor shall submit a list of key personnel assignments, including superintendent and other personnel in attendance at Project site. Identifying individuals and their duties and responsibilities listing addresses and telephone numbers, including home, office, and cellular telephone numbers and e-mail addresses. Providing names, addresses, and telephone numbers of individuals assigned as alternates in the absence of individuals assigned to Project.
  - 1. Post copies of the accepted list in project meeting room, in temporary field office, and by each temporary telephone. Keep list current at all times.

1.5 GENERAL COORDINATION PROCEDURES

- A. Coordination with other Contractors:
  - 1. For details on coordinating with other Contractors, refer to Article 701 Cooperation with Other Work Forces, Article 702 Coordination of the Work, and Article 703 Coordination of Public Contact in the General Contract Conditions, 2011 Edition.
- B. Minimum cooperation requirements with other contractors include the following, unless directed by the DEN Project Manager in writing:
  - 1. Regular meetings, minimum weekly.
  - 2. Construction schedule coordination.
  - 3. Staging area and access planning (to include employee shuttle routes).
  - 4. Deliveries.
  - 5. Traffic control.
  - 6. When and where required or specified, the Contractor shall develop appropriate coordination drawings for use by interfacing adjacent parties using the Denver International Airport site.
- C. The following is a list that includes, but is not limited to, all of the contractors that will be working in the area of the project limits:

- D. Coordination with DEN entities shall include but is not limited to the following:
1. Coordinate with Owner Contracted Communication Contractor.
  2. Coordinate with Utility Companies for utilities that are single sole source.
  3. Coordinate with Airport Security and DEN Maintenance for all security related services.
  4. Coordinate with DEN Life Safety Team for all issues related to fire alarm, fire protection systems in addition to compliance with all regulatory agencies.
  5. Coordinate all shutdowns and system interruptions in accordance with section 011400 "Work Sequence and Constraints."

1.6 Contract Administration Procedures:

- A. This Project will be administered in part using the current Project Management Information System (PMIS). Any processes necessary to properly administer the Contract and not included in the list below shall be addressed as acceptable to the DEN Project Manager. DEN Project Manager may modify the list below in serialized correspondence without constituting a change to the Contract. Administrative tools and processes shall not in any form waive any contractual or legal requirements of the law or the Contract. The Contractor shall attend all coordination meetings with the DEN Project Manager and the DEN Project Control Administrators to arrange for staff training, and technical support to facilitate the execution of electronic data management and control.
- B. Project Management Information Systems (PMIS): Oracle Unifier Enterprise Project Portfolio Manager (EPPM), or the Oracle Primavera P6.
- C. All submittals, RFIs, Pay Applications, Correspondence, change requests, and pricing proposals and settlement agreements shall be recorded and submitted using the current PMIS:
1. The Contractor shall follow the specified PMIS Access Request Procedure and adhere to all user license conditions.
  2. The Contractor shall sign the Information Technology Agreement (ITA) to comply with the DEN computer system security requirements and any contractual obligation to the software and service providers for the current PMIS software
  3. DEN will train the Contractor's staff on the use of the PMIS.
  4. At a minimum, the Contractor shall provide computer hardware and software to meet the following requirements and to run the following programs, as required for the project:
    - a. Internet connectivity that provides the necessary high-speed connection to perform all activities indicated in this Contract.
    - b. Internet Explorer version 8 or higher.
    - c. Based on the project, a specific Java JRE application may be required, which can be downloaded from the Internet. If needed, the revision and update number will be provided at NTP.
    - d. Other files capability pre-approved by the DEN Project Manager or as required by the DEN BIM Execution Plan

- e. Most current version of Revit, as per DEN requirements.

## 1.7 COORDINATION DRAWINGS

- A. Coordination Drawings, General: Prepare coordination drawings according to requirements in individual Sections, BIM Design Standards Manual and BIM Project Execution Plan (BPXP), and additionally where installation is not completely shown on Shop Drawings, where limited space availability necessitates coordination, or if coordination is required to facilitate integration of products and materials fabricated or installed by more than one entity. Coordination drawings will be the result of a Contractor driven Spatial Coordination effort as spelled out in the BPXP.
  1. Field verify all existing dimensions and any as-built dimensions, whether built by the Contractor or others, necessary to produce accurate coordination and working drawings.
  2. Content: Project-specific information, drawn accurately to a scale large enough to indicate and resolve conflicts. Do not base coordination drawings on standard printed data. Include the following information, as applicable:
    - a. Use applicable Models/Drawings as a basis for preparation of coordination drawings. Prepare sections, elevations, and details as needed to describe relationship of various systems and components.
    - b. Coordinate the addition of trade-specific information to the coordination drawings by multiple contractors in a sequence that best provides for coordination of the information and resolution of conflicts between installed components before submitting for review.
    - c. Indicate functional and spatial relationships of components of architectural, structural, civil, mechanical, and electrical systems.
    - d. Indicate space requirements for routine maintenance and for anticipated replacement of components during the life of the installation.
    - e. Show location and size of access doors required for access to concealed dampers, valves, and other controls.
    - f. Indicate required installation sequences.
    - g. Indicate dimensions shown on the Models/Drawings. Specifically note dimensions that appear to be in conflict with submitted equipment and minimum clearance requirements. Provide alternate sketches to DEN Project Manager indicating proposed resolution of such conflicts. Minor dimension changes and difficult installations will not be considered changes to the Contract.
- B. Coordination Drawing Organization: Using software as in the BPXP, the Contractor shall coordinate these systems per floor or zone per BPXP, and as follows:
  1. Floor Plans and Reflected Ceiling Plans: Show architectural and structural elements, and mechanical, plumbing, fire-protection, fire alarm, and electrical Work. Show locations of visible ceiling-mounted devices relative to acoustical ceiling grid. Supplement plan drawings with section drawings where required to adequately represent the Work.
  2. Plenum Space: Indicate subframing for support of ceiling and wall systems,

- mechanical and electrical equipment, and related Work. Locate components within ceiling plenum to accommodate layout of light fixtures indicated on Drawings. Indicate areas of conflict between light fixtures and other components.
3. Mechanical Rooms: Provide coordination drawings for mechanical rooms showing plans and elevations of mechanical, plumbing, fire-protection, fire alarm, and electrical equipment.
  4. Structural Penetrations: Indicate penetrations and openings required for all disciplines.
  5. Slab Edge and Embedded Items: Indicate slab edge locations and sizes and locations of embedded items for metal fabrications, sleeves, anchor bolts, bearing plates, angles, door floor closers, slab depressions for floor finishes, curbs and housekeeping pads, and similar items.
  6. Mechanical and Plumbing Work: Show the following:
    - a. Sizes and bottom elevations of ductwork, piping, and conduit runs, including insulation, bracing, flanges, and support systems.
    - b. Dimensions of major components, such as dampers, valves, diffusers, access doors, cleanouts and electrical distribution equipment.
    - c. Fire-rated enclosures around ductwork.
  7. Electrical Work: Show the following:
    - a. Runs of vertical and horizontal conduit.
    - b. Light fixture, exit light, emergency battery pack, smoke detector, and other fire-alarm locations.
    - c. Panel board, switchboard, switchgear, transformer, busway, generator, and motor control center locations.
    - d. Location of pull boxes and junction boxes dimensioned from column centerlines.
  8. Fire-Protection System: Show the following:
    - a. Locations of standpipes, mains piping, branch lines, pipe drops, and sprinkler heads.
  9. Review: DEN Project Manager will review coordination drawings to confirm that the Work is being coordinated, but not for the details of the coordination, which are Contractor's responsibility. If DEN Project Manager determines that coordination drawings are not being prepared in sufficient scope or detail, or are otherwise deficient, DEN Project Manager will so inform Contractor, who shall make changes as directed and resubmit.
- C. Coordination Digital Data Files: Prepare coordination digital data files according to the following requirements:
1. File Preparation Format: Same digital data software program, version, and operating system as original Drawings, unless approved otherwise by DEN Project Manager.
  2. File Preparation Format: Provided in the Project BIM Execution Plan operating in Microsoft Windows operating system.



3. File Submittal Format: Submit or post coordination drawing files as required in the Project BIM Execution Plan.
  4. The submittal must be logged in accordance with the submittal procedure
  5. For Fire Protection system; provide shop drawing and design calculations as approved by the building department. Submit as-built drawings in format as outline in BXP.
  6. For all projects, receiving official variance from the BIM requirements not utilizing BIM, coordination drawings must be submitted in acceptable digital format shall be in an industry recognized 3D AutoCAD model.
  7. BIM File Incorporation: DEN Project Manager will incorporate Contractor's coordination drawing files into Building Information Model for Revit as established for Project.
    - a. Contractor shall lead three-dimensional component conflict analysis as part of preparation of coordination drawings. Resolve component conflicts prior to submittal. Indicate where conflict resolution requires modification of design requirements by Architect or other sub-consultants.
  8. DEN Project Manager will furnish Contractor one (1) set of digital data files of Models and/or Drawings for use in preparing coordination digital data files.
    - a. The Design consultants and Contractors and Sub Contractors acknowledge and represent the following Right Of Reliance regarding Electronic Models and/or Drawing deliverables:
      - 1) Models may be transferred for allowing the recipients to develop derivative models to develop the means and methods by which to construct the project.
      - 2) It must be clear that each party be able to rely on the fact that the model furnished by others "match the 2D Contract Documents or shop drawings in their equivalent state of development"
- 1.8 Coordination with DEN Asset Management System:
- A. The full intent is to produce comprehensive record documents integrating existing data in the form of digital files and models, reconciled to actual field conditions, modifications or additions facilities or components of existing facilities according to new Contract Documents, and to produce record documents that could be incorporated into DEN asset management system.
  - B. Utilize the BIM to link all necessary data content to the model and follow the BXP as collaboratively modified by the Contractor, Designer, and DEN BIM Administrators and approved by DEN Project Manager
  - C. Provide the following information through the execution of the Contract for all elements and element types that DEN has designated as assets. The information shall include but is not limited to:
    1. Project title, number, project manager contact information, contractor and

- subcontractor contact information
- 2. Pertaining shop drawings
- 3. Operational Manuals and safety information, MSDS and cut sheets, and any pertinent technical information.
- 4. Details of all components' maintenance procedures and requirements.
- 5. Details of all applicable warranties including but not limited to; warranty providers, manufacturers information, warranty start and finish dates, contacts , bonding company name, consent of surety,
- 6. Equipment location (by room number and location description or grid location format acceptable to DEN Project Manager, for civil projects), equipment make, model, serial number, and other asset information as outlined in the DEN BIM DSM
- 7. List of all spare parts including but not limited to; equipment make and model, location, submittal number or link, and suppliers reordering information
- 8. Commissioning results, acceptance criteria, test reports, and Tab reports

#### 1.9 REQUESTS FOR INFORMATION (RFIs)

- A. General: Immediately on discovery of the need for additional information or interpretation of the Contract Documents, Contractor shall prepare and submit an RFI through the PMIS
  - 1. DEN Project Manager will distribute the RFIs to the proper entities.
  - 2. DEN Project Manager will coordinate and submit RFIs in a prompt manner to avoid delays in Contractor's Work or work of subcontractors
- B. DEN Project Manager has the right to reject-RFIs or those that do not contain proper information and required data to properly evaluate the request and respond in a timely manner.
- C. RFIs: Use PMIS to generate RFIs.
  - 1. Attachments shall be electronic files in Adobe Acrobat PDF format.
  - 2. Attachments include sketches, descriptions, measurements, photos, Product Data, Shop Drawings, coordination drawings, and other information necessary to fully describe items needing interpretation.
    - a. Include dimensions, thicknesses, structural grid references, and details of affected materials, assemblies, and attachments on attached sketches.
- D. For projects not using Unifier to create the RFI, the RFI must include a detailed, legible description of item needing information or interpretation and the following:
  - 1. Project name.
  - 2. Project number.
  - 3. Date.
  - 4. Name of Contractor.
  - 5. Name of DOR **and DEN Project Manager**.
  - 6. RFI number, numbered sequentially.

7. RFI subject.
  8. Specification Section number and title and related paragraphs, as appropriate.
  9. Drawing number and detail references, as appropriate.
  10. Field dimensions and conditions, as appropriate.
  11. Contractor's suggested resolution. If Contractor's suggested resolution impacts the Contract Time or the Contract Sum, Contractor shall state impact in the RFI.
  12. Contractor's signature.
  13. Attachments: Include sketches, descriptions, measurements, photos, Product Data, Shop Drawings, coordination drawings, and other information necessary to fully describe items needing interpretation.
- E. DEN Project Manager will review each RFI, determine action required, and respond. RFIs received by DEN Project Manager after 1:00 p.m. will be considered as received the following working day. Direct responses by any entity other than DEN Project Manager shall not be binding to the City and County of Denver. E-mails, and verbal conversations must be followed by an official RFI or proper contractual vehicle before it is considered for any additional compensation or time impact to the project terms and conditions.
1. The following Contractor-generated RFIs will be returned without action:
    - a. Requests for approval of submittals.
    - b. Requests for approval of substitutions.
    - c. Requests for approval of Contractor's means and methods.
    - d. Requests for coordination information already indicated in the Contract Documents.
    - e. Requests for adjustments in the Contract Time or the Contract Sum.
    - f. Requests for interpretation of DEN Project Manager's actions on submittals.
    - g. Incomplete RFIs or inaccurately prepared RFIs.
  2. DEN Project Manager's action may include a request for additional information, in which case DEN Project Manager's time for response will date from time of receipt of additional information.
  3. DEN Project Manager's action on RFIs that may result in a change to the Contract Time or the Contract Sum may be eligible for Contractor to submit Change Proposal according to Title 11 - Changes In the Work, Contract Price, or Contract Time in the General Contract Conditions, 2011 Edition as amended by Special Conditions.
    - a. If Contractor believes the RFI response warrants change in the Contract Time or the Contract Sum, notify DEN Project Manager in writing within five (5) days of receipt of the RFI response or the time required by Title 11 - Changes In the Work, Contract Price, or Contract Time in the General Contract Conditions, 2011 Edition
- F. RFI Log: For projects not utilizing the PMIS application, prepare, maintain, and submit a tabular log of RFIs organized by the RFI number. Submit log weekly. The log shall include but not limited to the following data:
1. Project name.

2. Name and address of Contractor.
3. Name and address of DEN Project Manager.
4. RFI number including RFIs that were returned without action or withdrawn.
5. RFI description.
6. Date the RFI was submitted.
7. Date DEN Project Manager's response was received.

**PART 2 - PRODUCTS (Not Used)**

**PART 3 - EXECUTION (Not Used)**

**PART 4 - MEASUREMENT**

4.1 METHOD OF MEASUREMENT:

- A. No separate measurement shall be made for work under this Section.

**PART 5 - PAYMENT**

5.1 METHOD OF PAYMENT:

- A. No additional Payment will be made for compliance with the requirements of this section.

END OF SECTION **013100**



## **SECTION 013119 - PROJECT MEETINGS**

### **PART 1 - GENERAL**

#### 1.1 RELATED DOCUMENTS

- A. Drawings and general provisions of the Contract, including General and Special Conditions and other Division 01 Specification Sections, apply to this Section.

#### 1.2 SUMMARY

- A. The Work specified in this Section requires the Contractor's Project Manager, Superintendent, and Quality Control representative to attend meetings scheduled by the DEN Project Manager for the collection and dissemination of information related to the subject Contract.
- B. The DEN Project Manager will prepare the minutes of each meeting and distribute them to each of the participants.

#### 1.3 REFERENCE DOCUMENTS

- A. Form CM-01, Preconstruction Meeting Agenda
- B. Form CM-62, Construction Meeting Agenda/Minutes

#### 1.4 OTHER MEETINGS

- A. The Contractor shall attend all other project related meetings as directed by the DEN Project Manager.

### **PART 2 - PRODUCTS (Not Used)**

### **PART 3 - EXECUTION**

#### 3.1 PRECONSTRUCTION MEETING

- A. A Preconstruction Meeting will be scheduled by the DEN Project Manager after the Contract has been signed by all parties. The purpose of this meeting is to introduce the City's Representatives to their counterparts in the Contractor's organization and to establish lines of communication between these representatives and outline some Contract requirements. The Contractor's key personnel shall attend this meeting.

- B. The DEN Project Manager will distribute a notice of this meeting, along with an agenda of the subjects to be addressed. Refer to form CM-01, Preconstruction Meeting Agenda.
- C. The DEN Project Manager will explain and discuss the responsibilities and authorities of the City, the Designer of Record, and the DEN Project Manager's organization.
- D. The Contractor shall introduce the Contractor's key personnel, subcontractors, and representatives and briefly describe each person's responsibilities.
- E. Explanations provided by the DEN Project Manager will not amend, supersede, or alter the terms or meaning of any Contract document, and the Contractor shall not claim reliance on such explanations as a defense to any breach or failure by the Contractor to perform as specified in the Contract.

### 3.2 CONSTRUCTION PROGRESS MEETINGS

- A. Progress meetings will be scheduled weekly and more often as necessary by the DEN Project Manager to promote the competent and timely execution of the Contract.
- B. The meetings will be held at the work site or at a location selected by the DEN Project Manager. Meetings will be chaired by the DEN Project Manager or the DEN Project Manager's representative.
- C. The Contractor's key personnel shall attend unless otherwise agreed by the DEN Project Manager.
- D. At a minimum, and as directed by the DEN Project Manager, the items detailed in CM-62, Construction Meeting Agenda/Minutes shall be addressed at each meeting. The items addressed in the meeting do not waive notification or submittal requirements as required elsewhere in the Contract.
- E. The DEN Project Manager will be responsible for publishing minutes of the meetings. Refer to form CM-62, Construction Agenda/Meeting Minutes.

## PART 4 - MEASUREMENT

### 4.1 METHOD OF MEASUREMENT

- A. No separate measurement shall be made for work under this Section.

## PART 5 - PAYMENT

### 5.1 METHOD OF PAYMENT

- A. No separate payment shall be made for work under this Section.

- B. All payments for any Work done under this contract shall be in accordance with Title 9  
- Compensation of the General Contract Conditions, 2011 Edition.

END OF SECTION **013119**





## SECTION 013210 - SCHEDULE

### PART 1 - GENERAL

#### 1.1 RELATED DOCUMENTS

- A. Drawings and general provisions of the Contract, including General and Special Conditions and other Division 01 Specification Sections, apply to this Section.

#### 1.2 SUMMARY

- A. The Work specified in this Section describes the procedures and requirements for scheduling and documenting the progress of the project.

1. Preliminary Construction Schedule.
2. Contractor's Construction Schedule.
3. Contractor's Monthly Construction Schedule update.
4. As-built Schedule.
5. Three-Week Look-Ahead Schedule.
6. Daily Construction Reports.
7. Submittal Schedule.
8. Fabrication Schedule.
9. Material Delivery Schedules, cranes, special equipment and staging status.
10. Special reports:
  - a. Weather impacts and mitigations.
  - b. Recovery Schedule and alternatives.

- B. Reference Documents

1. Article 1105 – Time Extensions in the General Contract Conditions, 2011 Edition.
2. Section 011100 "Summary of Work"
3. Section 011420 "Work Sequence and Constraints".
4. Section 012910 "Schedule of Values".
5. Section 013119 "Project Meetings"
6. Section 013300 "Submittal Procedures"

#### 1.3 DEFINITIONS

- A. Activity: A discrete part of a project that can be identified for planning, scheduling, monitoring, and controlling the construction project. Activities included in a Construction Schedule consume time and resources:

1. Critical Activity: An activity on the critical path that must start and finish on the planned early start and finish times.
2. Predecessor Activity: An activity that precedes another activity in the network.

3. Successor Activity: An activity that follows another activity in the network.
- B. Cost Loading: The allocation given in the Schedule of Values for the completion of an activity as scheduled. The sum of costs loaded for all scheduled activities must equal the total Contract Value unless otherwise approved by DEN Project Manager. All project costs, including those for stored materials and allowances, shall be loaded into the schedule and shall be balanced to where no activity is unfunded.
- C. Critical Path Method (CPM): A method of planning and scheduling a construction project where activities are arranged based upon defined relationships. Defined relationships determine when activities can be performed and the critical path for completing the Work.
- D. Critical Path: The longest chain of interdependent activities through the network sequence that establishes the shortest duration for completing the work and contains no float. The critical path shall be calculated as total float equal to but not less than zero days.
- E. Float: The amount of time that an activity in a network sequence can be delayed without causing a delay to subsequent activities and/or the completion date of the Work:
1. Float is not for the exclusive use or benefit of either the City or the Contractor but is jointly owned. Liability for delay to the Substantial Completion of the Work rests with the party whose actions, last in time, actually cause a delay to the Substantial Completion date.
  2. Free float is the amount of time an activity can be delayed without adversely affecting the early start of its successor activity.
  3. Total float is the amount of time that an activity may be delayed from early start without adversely affecting the Substantial Completion date.
- F. Resource Loading: The allocation of direct man-hours by trade, material, equipment, subcontractors, and all other resources required to complete each activity. The contractor shall account for the indirect man-hours in the cost. The indirect labor hours could be tracked and reported separately, if agreed upon between the Contractor and the DEN Project Manager prior to the start of the Work.
- G. Direct Man-hours: Man-hours related only to the physical construction of the Work, i.e., masonry, mechanical, electrical, drywall, carpeting, etc.
- H. Indirect Man-hours: Man-hours related to support of the physical construction of the Work, i.e., cleanup, mobilization, traffic control, temporary activities, badging, supervision and overhead, etc.
- I. Work Breakdown Structure (WBS): A hierarchical arrangement of the activities that allows for the roll-up and summarization to a predetermined level. The level of breakdown shall be agreed upon by the Contractor and the DEN Project Manager prior to the start of Work.

## 1.4 SUBMITTALS

### A. Scheduler Qualifications

1. Scheduling Consultant Qualifications: A professional specialist, experienced in CPM scheduling and reporting with capability of producing CPM reports and diagrams who can quickly produce these reports/diagrams within 24 hours of the DEN Project Manager's request. Review methods and procedures related to the set-up in the PMIS of Preliminary Construction Schedule and Contractor's Construction Schedule, including, but not limited to, the following:
  - a. Review content and format for reports.
  - b. Verify availability of qualified personnel needed to develop and update schedule.
  - c. Discuss constraints, including phasing, area separations, interim milestones, and partial Owner occupancy.
  - d. Review delivery dates for Owner-furnished products.
  - e. Review submittal requirements and procedures.
  - f. Review time required for review of submittals and resubmittals.
  - g. Review requirements for tests and inspections by independent testing and inspecting agencies.
  - h. Review time required for Project closeout and Owner start-up procedures, including commissioning activities.
  - i. Review procedures for updating schedule.
  - j. Review requirements for content and input of direct man-hour resources in activities.
  - k. Review requirements for cost loading of activities.

### B. Format for Submittals: All schedules shall be submitted in the following format:

1. The Contractor shall develop Critical Path Method (CPM) Schedule utilizing the applicable PMIS. The schedule shall utilize the Precedence Diagram Method (PDM) and be depicted in Gantt Chart view.
2. All schedules shall be submitted to the DEN Project Manager electronically in a PDF format that enables the fields, rows, and columns to be expanded, as required. Additionally, the PDF format used must allow import/export, manipulation, and generation of reports to evaluate and review any part of the schedule.
3. Export file shall use the following naming convention. For example, 161510 BL – Parking Structure MOD4E Baseline
  - a. Project ID: To be assigned at Schedule Conference Meeting, i.e., 161510
  - b. Project Name: Reference Project Manual for Project Name, i.e., Parking Structure MOD 4E
  - c. Identify schedule type: Baseline, Update or Revision, i.e., BL, U, and R
4. All schedules shall contain a title block showing:
  - a. Project name.
  - b. Contractor number.

- c. Contractor's name.
  - d. Data date.
  - e. Symbol legend.
5. All schedules shall contain a time-scale at the top showing month and weeks.
6. The activity table layout shall include, but not limited to, the following columns:
  - a. Activity ID.
  - b. Activity name.
  - c. Original duration.
  - d. Schedule percent complete.
  - e. Start date
  - f. Finish date
  - g. Total Float.
7. A narrative report shall accompany all schedules.
8. A mitigation report shall be required when at the discretion of either party it becomes apparent that the project is not progressing on time regardless of the cause of delays and impacts, or issued construction changes have negative impact and require a mitigation effort through several viable alternatives. The mitigation report shall detail the measures proposed by the Contractor to mitigate the impacts of the delay in order to meet the planned project completion date.

#### 1.5 PRELIMINARY CONSTRUCTION SCHEDULE:

##### A. Gantt Chart Schedule

1. Submit Gantt chart-type CPM Construction Schedule at the pre-construction meeting.

##### B. Preparation

1. Indicate each significant construction activity separately.
2. Identify first workday of each week with a continuous vertical line.
3. Outline significant construction activities for first sixty (60) days of construction.
4. Include skeleton diagram for the remainder of the Work.
5. The Preliminary Schedule shall show all significant work tasks that occur in the first sixty (60) days, including planning, mobilization, shop drawings and technical submittals and approval time, procurement, fabrication and construction.
6. It shall identify work items or milestones that affect or are affected by City, other Contractor's work, utilities, and other third parties and it shall list major submittals required by the Contract.

##### C. Narrative

1. The Preliminary Schedule shall be accompanied by a narrative describing the Contractor's approach to mobilization, procurement, and construction during the first sixty (60) days.
2. The narrative shall elaborate based on durations, production rates, major

equipment to be used, and shall identify all major assumptions used to develop the schedule.

- D. Approval of Preliminary Construction Schedule will not constitute approval of Schedule of Values.
- E. The DEN Project Manager will respond within 14 days to the Preliminary Schedule submittal with either acceptance or direction to revise and resubmit.
- F. In lieu of the Preliminary Schedule, the Contractor may, at the Contractor's own discretion, submit the Construction Schedule at the Preconstruction Meeting. If the Construction Schedule is submitted in lieu of the Preliminary Schedule, the DEN Project Manager will respond within thirty (30) days with acceptance or direction to revise and resubmit within ten (10) days.

## 1.6 CONTRACTOR'S CONSTRUCTION SCHEDULE

- A. The Contractor shall submit the Initial Construction Schedule thirty (30) days after the Notice to Proceed (NTP). Upon acceptance from the DEN Project Manager and the DEN Scheduler, the Initial Construction Schedule shall become the Baseline Schedule for the duration of the project.
- B. The DEN Project Manager will respond within 14 days with acceptance or direction to revise and resubmit.
- C. Failure of the contractor to have a Construction Schedule accepted by DEN Project Manager will be considered cause for withholding progress payment.
- D. The acceptance of the schedule is for general conformity to the Contract requirements and shall not constitute any relief of any Contract requirements.
- E. Failure to include any work item required for performance of this Contract shall not excuse the Contractor from completing all Work within applicable completion dates, regardless of the City's acceptance of the schedule.
- F. Preparation:
  - 1. Project Duration
    - a. Extend schedule from date of established for the NTP to date of Substantial Completion and Final Completion.
    - b. Contract completion date shall not be changed by submission of a schedule that shows an early completion date, unless specifically amended by Change Order.
  - 2. Activities
    - a. Treat each building floor or separate area as a separate numbered activity for each main element of the Work. Prepare a list of all activities required to complete the Work and indicate the estimated time duration, sequence

requirements, and relationships of each activity in relation to the other activities.

3. Activity Duration:
  - a. Define activities so no construction activity is longer than twenty (20) days, unless specifically allowed by DEN Project Manager. Include estimated time frames for the following activities:
    - 1) Preparation and processing of submittals.
    - 2) Mobilization and demobilization.
    - 3) Purchase of materials.
    - 4) Delivery of materials.
    - 5) Fabrication of materials
    - 6) System shutdown request and approval
    - 7) Utility/system interruptions
    - 8) Installation
    - 9) Work by City, other contractors, utilities and other third parties that may affect or be affected by Contractor's activities.
    - 10) Startup, Testing and Commissioning
    - 11) Punch list and Final Completion.
4. Critical Path Activities:
  - a. No more than twenty-five (25) percent of the activities may be on the critical path, unless approved IN WRITING by DEN Project Manager.
  - b. Identify critical path activities, including those for interim completion dates.
  - c. Scheduled start and completion dates shall be consistent with Contract milestone dates.
5. Procurement Activities:
  - a. Include procurement activities for long lead items and major items as separate activities in schedule.
  - b. Procurement cycle activities including, but are not limited to, submittals, approvals, purchasing, fabrication and delivery.
6. Submittal Review Time:
  - a. Include review and re-submittal times indicated in Technical Specification 013300 "Submittal Procedures" in schedule unless time frame is reduced by approval of the DEN Project Manager.
  - b. Coordinate submittal review times in Contractor's Construction Schedule with submittal schedule.
7. Substantial Completion:
  - a. Indicate date established for Substantial Completion.
8. Constraints:

- a. Include constraints and work restrictions indicated in the Contract Documents and as follows in schedule, and show how the sequence of the Work is affected.
  - 1) Phasing:
    - a) Arrange list of activities in schedule by phase or Work Breakdown Structure (WBS).
    - b) Coordinate phasing and constraint with those established in Technical Specification Section 011400 "Work Sequence and Constraints".
  - 2) Products Ordered in Advance:
    - a) Include separate activity for each product.
    - b) Include delivery date indicated in Technical Specification Section 011100 "Summary of Work".
    - c) Delivery dates indicated stipulate the earliest possible delivery data.
  - 3) Owner-furnished Products:
    - a) Include separate activity for each product.
    - b) Include delivery date indicated in Technical Specification Section 011100 "Summary of Work".
    - c) Delivery dates indicated stipulate the earliest possible delivery date.
9. Milestones:
  - a. Include milestone indicated in the Contract Documents in schedule, including, but not limited to, the NTP, phasing requirements, Substantial Completion and Final Completion.
    - 1) Resource Loading of Construction Schedule:
      - a) Coordinate with DEN Project Control Staff and DEN Project Manager for the requirements below
      - b) Activities shall be resource loaded with direct man-hours required to perform the physical construction of the project. Indirect man-hours shall not be included as resources to activities.
    - 2) Contract Modifications:
      - a) For each proposed contract modification and concurrent with its submission, prepare a time-impact analysis to demonstrate the effect of the proposed change to the overall project schedule



## 1.7 CONSTRUCTION SCHEDULE MONTHLY UPDATES

- A. The Contractor shall submit a monthly progress schedule at the end of each month following the NTP. At the end of each month, the Contractor and DEN Project Manager shall agree on the progress of the work and the Contractor shall update the Construction Schedule accordingly. This review does not constitute an acceptance of the Construction Schedule and shall not be used for the purpose of modifying the initially accepted Construction Schedule.
- B. Failure of the Contractor to have a Construction Schedule accepted by the DEN Project Manager will be considered cause for withholding progress payment per Article 306 - Working Hours and Schedules and Article 909 - Additional Withholding of Progress Payments of the General Contract Conditions, 2011 Edition.
- C. The Contractor's monthly progress schedule shall include a written narrative describing the overall progress of the Work, provide a critical path analysis, discuss significant problems with proposed corrective action, and how the status of major changes and any other changes are affecting the project schedule.
- D. Concurrent with making revision to the schedule, prepare a tabulated report showing the following and include in the narrative report:
1. Identification of activities that have changed.
  2. Changes in early and late start dates.
  3. Changes in early and late finish dates.
  4. Changes in activity durations-for remaining work activities only.
  5. Changes in critical path.
  6. Change in total float
  7. Changes in contract duration.
- E. Changes to the Schedule:
1. The Construction Schedule may be changed when one or more of the following events occur:
    - a. When a Change Order significantly affects the contract completion date or sequence of work.
    - b. When the Contractor elects to change the sequence or duration of work items affecting the critical path.
    - c. When the City directs a change that affects a milestone dates specified in the Special Conditions or alters the length of a critical path.
  2. Minor revisions submitted at monthly progress review meeting are not considered as changes in this context.
- F. If, after submitting a request for change to the Construction Schedule, the DEN Project Manager does not agree with the request, the DEN Project Manager will schedule a meeting with the Contractor to discuss the differences. If a settlement cannot be reached on the change in the Construction Schedule, or if the Contractor has failed to submit revisions to the network, the DEN Project Manager has the option of providing

suggested logic or duration changes in all subsequent update schedules. The suggested logic and/or duration times will remain in effect until the change in the Construction Schedule is settled or until the logic and duration are superseded.

1.8 AS-BUILT CONSTRUCTION SCHEDULE:

- A. After all Contract Work items are complete, the contractor shall submit an as-built Construction Schedule showing actual start and finish dates for all work items and milestones.

1.9 SCHEDULE NARRATIVES

- A. In addition to the schedule, the Contractor shall submit a narrative that explains the basis for the Contractor's determination of construction logic.
- B. It shall include estimated quantities and production rates, hours per shift, workdays per week, and types, number and capacities of major construction equipment to be used and whether the Contractor plans to work weekends.

1.10 SUBCONTRACTOR COORDINATION

- A. The Contractor shall schedule and coordinate the work of all of its subcontractors and suppliers including their use of the worksite.
- B. The contractor shall keep the subcontractors and suppliers informed of the project Construction Schedule to enable the subcontractors to plan and perform their work properly.

1.11 THREE WEEK LOOK-AHEAD SCHEDULE

- A. The Contractor shall provide the DEN Project Manager an electronic copy prior to and a minimum of four (4) hard copies of the Contractor's Three (3) Week Look-Ahead Schedule for review at the DEN Project Manager's weekly progress meeting.
- B. The schedule shall be in bar chart format based on the approved accepted CPM Baseline Schedule and shall include dates of testing activities, anticipated dates of inspection by DEN and other agencies, activities in progress, percentage of completion of activities, and responsible subcontractor for the activities.

1.12 RECOVERY SCHEDULE

- A. If the latest completion time date for any work item does not fall within the time allowed by the Construction Schedule, the sequence of work or duration shall be revised by the Contractor through concurrent operations, additional manpower, additional shifts or overtime, additional equipment, or alternative construction methods until the schedule produced indicates that all significant contract completion dates, occupancy dates and

milestones will be met.

- B. No additional costs will be allowed if such expediting measures are necessary to meet the agreed completion date or dates except as provided elsewhere in the Contract Documents.
- C. When periodic update indicates the Work is behind the current approved schedule, submit a separate Recovery Schedule indicating means by which Contractor intends to regain compliance with the schedule.
- D. Provide a narrative indicating changes to working hours, working days, crew sizes, and equipment required to achieve compliance, and date by which recovery will be accomplished. The narrative shall be submitted in accordance with Article 1105 – Time Extensions in the General Contract Conditions, 2011 Edition.

#### 1.13 CONTRACT EXTENSIONS

- A. If the Contractor is granted an extension of time for completion of any milestone or contract completion date under the provisions of the Contract, the determination of the total number of extended days will be based upon the current analysis of the schedule and upon all data relevant to the extension. Such data shall be incorporated into the next monthly update of the schedule.
- B. The Contractor acknowledges and agrees that delays in work items that, according to schedule analysis, do not affect any milestone dates or the Contract completion date shown on the CPM Network Schedule at the time of the delay will not be the basis for a Contract extension.

#### 1.14 COORDINATION

- A. Pre-scheduling Conference: Schedule conference at Pre-Construction meeting to comply with requirements in Section 013100 "Project Management and Coordination." Review methods and procedures related to setting up the Preliminary Construction Schedule and Contractor's Construction Schedule, including, but not limited to, the following:
  - 1. Review content and format for reports.
  - 2. Verify availability of qualified personnel needed to develop and update schedule.
  - 3. Discuss constraints, including phasing, area separations, interim milestones, and partial Owner occupancy.
  - 4. Review delivery dates for Owner-furnished products.
  - 5. Review submittal requirements and procedures.
  - 6. Review time required for review of submittals and resubmittals.
  - 7. Review time required for Shutdown request and approval.
  - 8. Review requirements for tests and inspections by independent testing and inspecting agencies.
  - 9. Review time required for Project closeout and Owner startup procedures, including commissioning activities.

10. Review procedures for updating schedule.
  11. Review requirements for content and input of direct man-hour resources in activities.
  12. Review requirements for cost loading of activities.
- B. Coordinate Contractor's Construction Schedule with the Schedule of Values.
- C. Work items in the Construction Schedule shall be identified in a Work Breakdown Structure (WBS) format that corresponds with the technical specifications.
- D. At a minimum WBS shall correspond to the first tier level of the Master Format.
- E. Secure time commitments for performing critical elements of the Work from entities involved.
- F. Coordinate each construction activity in the network with other activities and schedule them in proper sequence.

## **PART 2 - PRODUCTS (Not Used)**

## **PART 3 - EXECUTION (Not Used)**

## **PART 4 - MEASUREMENT**

### 4.1 METHOD OF MEASUREMENT

- A. No separate measurement shall be made for work under this Section.

## **PART 5 - PAYMENT**

### 5.1 METHOD OF PAYMENT

- A. No separate payment will be made for work under this Section.

END OF SECTION 013210



## **SECTION 013223 - CONSTRUCTION LAYOUT, AS-BUILT AND QUANTITY SURVEYS**

### **PART 1 - GENERAL**

#### **1.1 RELATED DOCUMENTS**

- A. Drawings and general provisions of the Contract, including General and Special Conditions and other Division 01 Specification Sections, apply to this Section.

#### **1.2 SUMMARY**

- A. This Section covers Denver International Airport (DEN) procedures and accuracy requirements for survey services for construction layout, as-built, and quantity surveys.
- B. Before commencing any field surveys on DEN property, the Contractor shall coordinate a pre-survey preparation activities meeting. This meeting is to be arranged through the Denver International Airport (DEN) Project Manager's Office with the attendance of the Contractor, the Contractor's surveyor and the DEN Survey Section. The Contractor is responsible for obtaining DEN related survey guidance, National Geodetic Survey (NGS) control stations, projection parameters, and training materials from the DEN Survey Section prior to beginning any survey work.
- C. Reference Contract General Conditions.
- D. Survey Project Checklist, provided after the end of this Section, will be reviewed at the pre-survey preparation activities meeting.

#### **1.3 REFERENCE DOCUMENTS:**

- A. Section 013300 "Submittal Procedures"
- B. Section 013325 "Shop and Working Drawings, Product Data and Samples".
- C. Federal Aviation Administration Advisory Circular 150/5300-16A - "General Guidance and Specifications for Aeronautical Surveys: Establishment of Geodetic Control and Submission to the National Geodetic Survey".
- D. Federal Aviation Administration Advisory Circular 150/5300-17C - "Standards for Using Remote Sensing Technologies in Airport Surveys".
- E. Federal Aviation Administration Advisory Circular 150/5300-18B - "General Guidance and Specifications for Submission of Aeronautical Surveys to NGS: Field Data Collection and Geographic Information System (GIS) Standards".
- F. DEN Building Information Modeling (BIM) Design Standards Manual (DSM) and

Construction Plan Manual, Technical Specifications Division 1.

G. Colorado Department of Transportation (CDOT) Survey Manual.

#### 1.4 SUBMITTALS

A. Refer to Section 013300 "Submittal Procedures" and Section 013325 "Shop and Working Drawings, Product Data and Samples" for the submittal process.

B. Survey Statement of Work (SSOW):

1. The Contractor must develop a complete SSOW and submit it to the DEN Project Manager. The SSOW is the Contractor's written description of the Contractor's methodology for surveying services that will be provided as part of the Project, including specific features that will be surveyed, action items, timelines necessary airport resources and general information.
2. SSOW must be submitted within ten (10) working days of the Notice to Proceed (NTP) and prior to commencement of any survey or layout work on the site.
3. The SSOW will be reviewed and approved by the DEN Survey Section. Under no circumstances will work begin until the SSOW has been accepted. Review comments and/or approval will be sent to the DEN Project Manager within three (3) working days of the delivery of such document to the DEN Survey Section.

C. Survey and layout data must be submitted in the format indicated below. The data must be submitted immediately after completion and shall be certified and/or stamped by a current Colorado Registered Professional Land Surveyor where it is required by the Contract Documents.

1. All Raw Data files, either GPS, digital levels or conventional total station must use a Trimble format.
2. All copies of original pages of field notes or electronic field notes must be in Adobe Portable Document Format (PDF).
3. All original field notebooks used for this Project must be submitted at the end of Contract.
4. All as-built points files must be in either CSV or TXT format.
5. All CAD drawings must be in Autodesk Civil 3D format.
6. CAD layers are specified in DEN Design Standards Manual Volume 12.
7. DEN will provide the Autodesk Civil 3D drawing template.

D. Survey and Quality Control Plan (SQCP):

1. The Contractor must develop a complete SQCP and submit it to the DEN Project Manager. The SQCP is the Contractor's written description detailing the Contractor's methodologies for data collection, data safeguarding and quality assurance. Provide insight on how the Contractor will completely check all data to ensure it is complete, reliable, and accurate. Identify data safeguards used to protect this sensitive and safety critical data. Utilize a checklist based quality control process with definable and repeatable standards for each element ensuring consistency of work between different personnel within an organization.

Submit the plan in a non-editable format such as Adobe Portable Document Format (PDF).

2. The SQCP must be submitted within ten (10) working days of the NTP and prior to commencement of any survey or layout work on the site.
3. The SQCP will be reviewed and approved by the DEN Survey Section.
4. Under no circumstances will Survey work begin until the SSOW has been accepted. Review comments and/or approval will be sent to the DEN Project Manager within three (3) working days of the delivery of such document to the DEN Survey Section.

E. Weekly Project Status Report:

1. Submit a project status report via email DEN Project Manager every Monday by 2:00 P.M. Mountain Time, from the date of the task order until the date of Substantial Completion. Include in the reports the percentage complete for each of the major portions of the Work with the estimated completion date or completion date. Provide the status of ongoing work, with expected completion dates, and any unusual circumstances and/or deviations from this guidance. Status reports should be brief and contain the current information in the text of the email. See the example of a Project Status Report as provided after the end of this Section.

F. Final Project Survey Report:

1. The Final Project Survey Report, if required, use format from AC 150/5300-18B 2.6.4.
2. Final Project Survey Report must be stamped and signed by a current Colorado Registered Professional Land Surveyor.

## 1.5 EQUIPMENT

A. Equipment Calibration:

1. Equipment must be regularly checked, and calibrated for accuracy at the beginning of any survey project to ensure that the equipment is operating appropriately. Errors due to poorly maintained or malfunctioning equipment will not be accepted. If any equipment errors are found to exist, they must be reported to the DEN Survey Section prior to the start of any surveying. These errors will need to be verified and eliminated prior to performing any survey work. For projects lasting longer than six (6) months, the checking, and calibration of equipment shall be repeated. Furthermore, documentation must verify such equipment has met acceptable tolerances.
2. The Contractor MUST submit to the DEN Project Manager written proof that survey equipment, as listed in the SQCP plan has been checked and calibrated before commencing any survey work. This could be in the form of field notes. If repairs are made, documentation of such repairs from an authorized equipment vendor is required

B. See CDOT Survey Manual for acceptable procedures for calibrating equipment



electronic survey instruments adjustments, calibration or repairs:

1. All electronic survey instruments shall be repaired, adjusted, or calibrated only by an authorized equipment vendor or manufacturers service department.
2. A calibration check on all types of electronic survey instrumentation is essential to obtain and maintain the tolerances required for any DEN project. At the beginning of any DEN project, all survey equipment utilized to perform the survey shall be calibrated by the surveyor in charge of the Project.
3. See CDOT Survey Manual for acceptable procedures for calibrating equipment.

C. Baseline Calibration Requirements:

1. See CDOT Survey Manual for the procedures to check the survey equipment and the method of reporting the findings to the DEN Project Manager and the DEN Survey Section.
2. The Contractor MUST submit to the DEN Project Manager written proof that survey equipment has been checked and calibrated before commencing any survey work. This could be in the form of field notes. If repairs are made, documentation of such repairs from an authorized equipment vendor is required.

1.6 SURVEY CONTROL

- A. All airport construction project surveys MUST USE the most current coordinate system. No prior coordinate systems are supported. Surveys MUST utilize the most current coordinate system for collecting construction as-built information.
- B. Since the DEN LDP utilized the NAD83 (2007) data, all NGS horizontal points MUST use the NAD83 (2007) data. The DEN Survey Section will provide this data during the mandatory pre-survey preparation activities meeting. The DEN Survey Section will also provide coordinates for all NGS Control Points in DEN LDP based upon the location of the Project.
- C. Since DEN has established NGS horizontal control points, the Contractor MUST use the published latitudes, longitudes, and heights with the projection parameters for these control points that are received and NOT the DEN LDP rectangular coordinates for base station setups for the Geodetic Verification Survey. The Contractor must verify each NGS Horizontal and Vertical primary control point stations by:
1. Physically visiting each control station to determine its usability and checking its identity.
  2. Ascertaining its unmoved position.
  3. Determining its condition, stability, visibility.
  4. The submission of a recovery report to NGS if one has not been recently recorded.
- D. Geodetic Verification Survey Instructions and Procedures:
1. The geodetic verification survey is created to insure the stable position of the DEN control points that are used to reference the temporary design/construction

control points to the National Spatial Reference System (NSRS). Acceptable monuments will be identified by the DEN Survey Section and will be limited to monuments of the NSRS with permanent identifiers (PIDS) and published positions and elevations. Temporary design/construction control points established for such project will be referenced by direct measurement to at least two (2) separate NGS control stations

- a. The Contractor will attempt to recover each identified monument and determine its condition, stability, and suitability for the intended use. A location sketch and visibility diagram will be prepared for each station. A minimum of three (3) digital photographs, one of each type described in AC 150/5300-18B, Section 1.5.2.1, will be captured, captioned, and properly named. A recovery note will be filed with NGS if no current recovery is shown in the NSRS database.
- b. After recovering the identified NSRS NGS control stations that are located on DEN property, the procedure to verify the control points are as follows:
  - 1) When using a remote GPS base station on the airfield, the Contractor must occupy the Primary Airport Control Station (PACS) and observe the Secondary Airport Control Station (SACS) for a duration of at least ten (10) minutes (600 epochs), along with a five (5) second collection interval. Then reverse the setup, occupy the SACS and observe the PACS for a duration of at least ten (10) minutes (600 epochs), along with a five (5)-second collection interval. The end results are two (2) independent GPS observations. Compare the newly measured distances or inverse distances (from new observations) against the distances determined from the published positions. Submit results to the DEN Survey Manager and DEN Survey Section in Microsoft Excel format.
  - 2) When using a Virtual Reference Station (VRS) on the airfield, the Contractor must observe the PACS and the SACS for a duration of at least ten (10) minutes (600 epochs), along with a five (5)-second collection interval. Then reverse the setup, occupy the SACS and observe the PACS for a duration of at least ten (10) minutes (600 epochs), along with a five (5)-second collection interval. The end results are two (2) independent GPS observations. Compare the newly measured distances or inverse distances (from new observations) against the distances determined from the published positions. Submit results to the DEN Survey Manager and DEN Survey Section in Microsoft Excel format.
  - 3) When using conventional methods on the airfield, measure the distance between the PACS and SACS using a calibrated electronic distance meter instrument (EDMI). Compute either the inverse using the NGS program INVERS3D (available on the NGS website at <http://www.ngs.noaa.gov/TOOLS/>) or a comparable commercial product. Compare the newly measured distances or inverse distances, from new observations, against the distances determined from the published positions. Submit results to the DEN Survey Manager and DEN Survey Section in Microsoft Excel format.

- 4) Obtain elevation checks either from GPS observations or from digital levels. The distances must agree within, plus or minus, three ( $\pm 3$ ) cm; the difference in ellipsoidal height must agree within, plus or minus, four ( $\pm 4$ ) cm, and the difference in orthometric height must agree within, plus or minus, five ( $\pm 5$ ) cm. If the tolerances are not met, the data must be recollected.
- 5) Provide the results or the comparisons as part of the observational data in a report to the DEN Project Manager to be reviewed and approved by the DEN Survey Section prior to the start of construction and include this approved report in the final report.
- 6) Submit a recovery report for the NGS horizontal control stations to the NGS.

E. The Following are Limitations and Additional Information on NGS Control Stations and NGS Benchmarks (Refer to the NGS website.):

1. The use of control monuments and projection parameters for construction layout other than those shown on the Contract Drawings or furnished by or approved by the DEN Survey Section is STRICTLY PROHIBITED. Use of other monuments is solely at the risk of the Contractor.
2. The DEN Survey Section will provide the contractor with the projection parameters and any assistance in implementing the current coordinate system. It is up to the Contractor to use the correct methodology in performing any survey task that shall be submitted to the DEN Project Manager and reviewed during the pre-survey preparation activities meeting.
3. The DEN Survey Section will need all pertinent data from the contractor to check and verify that the Contractor implemented the current coordinate system correctly.

F. Modifications to AC 150/5300-18B, Section 2.6.10.1.1, Verification of Survey Marks:

1. DEN is modifying the requirement for verification of PACS and SACS and is replacing it with a requirement to verify the unmoved position and elevation of both the PACS and SACS for any airside projects and any two (2) DEN approved NGS horizontal control stations for any landside project.
2. The surveyor must follow the same verification procedure as stated in paragraph 1.6.C of this Section.

G. Reporting Damage or Errors of NGS Control Stations:

1. Report damaged or destroyed airport control points, benchmarks, and section corner monuments promptly to the DEN Project Manager.
  - a. If section corner monuments are damaged or destroyed during construction activities, such points shall be re-established pursuant to Laws of the State of Colorado Regulating the Practice of Land Surveying by a Registered Professional Land Surveyor in the State of Colorado.
  - b. If NGS control stations or NGS benchmarks are damaged, moved, altered, or destroyed by the Contractor, the City's cost of reestablishing such points

shall be borne by the Contractor.

- c. The City will not be responsible for any increased costs or delays to the Contractor relating to reference points, airport control points, or benchmarks that are damaged, moved, altered, or destroyed by the Contractor or its subcontractors, suppliers, agents or employees or other Contractors working on the site.
2. Report alleged errors in NGS control stations or NGS benchmarks promptly to the DEN Project Manager.
    - a. Discontinue use of NGS control stations or NGS benchmarks alleged to be in error until the accuracy of points can be verified or as directed.
    - b. Claims for extra compensation for alteration or reconstruction allegedly due to errors in NGS control stations or NGS benchmarks will not be allowed unless original NGS control stations and NGS bench marks still exist or substantiating evidence proving error is furnished by the Contractor, and unless the Contractor has reported such errors to the DEN Project Manager as specified herein.

## 1.7 TEMPORARY SURVEY CONTROL

- A. The Contractor MUST set a minimum of 1" copper plug; a PK (surveying) nail in asphalt or a 5/8" rebar with cap stamped "Control Point" and the Surveyor's Professional Land Surveyors' number, in natural ground. Any other type of material used for control points MUST be approved first.
- B. When a contractor establishes temporary control points for DEN survey work the Contractor MUST follow FAA guidelines. All temporary control points must be referenced to the NSRS using the NGS control stations provided by the DEN Survey Section. Temporary control may be necessary based on project site location. Below are the acceptable means to establish temporary geodetic control for DEN design or construction projects:
  1. Temporary control must be established under close cooperation with the DEN Survey Section following the procedures outlined in AC150/5300-16 "General Guidance and Specifications for Aeronautical Surveys.
  2. Establishment of Geodetic Control and Submission to National Geodetic Survey" shall be required only in the following cases:
    - a. Large airport airfield construction project that significantly changes the airport geometry and would trigger the need to acquire new Digital Stereo Imagery following AC 150/5300-17 "General Guidance and Specification for Aeronautical Survey Airport Imagery Acquisition and Submission to the National Geodetic Survey". Examples include a new runway and taxiway complex, significant modification of existing runway or taxiway system, development of new outboard deice pad complex or establishment of new mid airfield concourse and terminal complex. The size and complexity of the Project will dictate the need to acquire new digital stereo imagery for significant construction.

- b. Construction that establishes a new ILS CAT II/III Operations.
  - c. New Instrument Development Procedure.
  - d. New Airport Layout Plan Survey Update.
  - e. New Airport Obstruction Chart Update.
  - f. New Airport Mapping Database.
3. On DEN construction projects, the Contractor, excluding large airport airfield construction projects, may use temporary control points on their project site. These temporary control points must be referenced to the nearest DEN primary control points and MUST BE referenced vertically to two (2) different benchmarks. Also, all surveyors MUST obtain permission to establish temporary control points on DEN property by means of communicating with the DEN Survey Section.
4. In addition, all vertical control MUST BE established only using a digital level and collected using the digital software to reduce transposition errors unless otherwise authorized by the DEN Survey Section.
5. Minimum Construction Horizontal and Vertical Accuracy Tolerance:
  - a. Adjustments:
    - 1) No Horizontal adjustment of the survey field data will be permitted without the written consent of the DEN Project Manager and the DEN Survey Section. If it is determined that an adjustment is necessary, a weighted least squares adjustment method is recommended.
  - b. Primary Control Benchmark Minimum Vertical Accuracy Tolerance:
    - 1) Setting of primary control benchmarks shall meet the Minimum Vertical Accuracy Tolerance of a NGS Second Order Class II as the square root of the total horizontal distance of the level loop in miles multiplied by 0.035 feet.
    - 2) The Primary Control Benchmarks must be NGS Published Vertical Points.
  - c. Secondary Control Benchmark Minimum Vertical Accuracy Tolerance:
    - 1) Setting of secondary control benchmarks for construction shall meet the Minimum Construction Vertical Accuracy Tolerance of the square root of the total horizontal distance of the level loop in miles multiplied by 0.035 feet.
6. Whether establishing temporary control points or not, the Contractor must set up a pre-survey preparation activities meeting with the DEN Project Manager and DEN Survey Section to discuss Geodetic Control Verification, obtain pertinent survey data, and projection parameters before the commencement of any survey work.
7. If temporary control points are needed, the Contractor can set and collect temporary control while performing as outlined in Part 1 of this Section. This procedure requires a ten (10) minute (600 epochs) for each temporary control point set. Once the data is collected the Contractor is required to submit to the

DEN Project Manager all GPS raw data in a Trimble format with a spreadsheet that displays the comparison from each observation of the NGS control stations and the Contractor's temporary control points. Only the redundant values of the temporary control points should be averaged. The results must be reviewed and approved by the DEN Survey Section, allowing at least seventy-two (72) hours to review and either approve or reject the temporary control. All temporary control points MUST BE accepted before any survey construction work can commence.

## **PART 2 - PRODUCTS (Not Used)**

## **PART 3 - EXECUTION**

### **3.1 CONSTRUCTION LINES AND GRADES**

- A. The Contractor's surveyor shall make surveys and layouts as necessary to delineate the Work. As a part of such surveys, the Contractors Surveyor shall furnish, establish, and maintain in good order, survey control points that may be required for the completion of the Work
- B. The DEN Project Manager shall have the right to check surveys and layouts made by the Contractor prior to approving any of the Work. The Contractor shall give advance notice of not less than forty-eight (48) hours to the DEN Project Manager to enable such checking prior to placing any work. The Contractor shall furnish assistance as may be required for checking purposes when so requested by the DEN Project Manager.
- C. The Contractor shall furnish skilled labor, instrument platforms, ladders, and such other temporary structures as may be necessary for making and maintaining points and lines in connection with the surveys required.
- D. DEN may draw the Contractor's attention to errors or omissions in lines or grades, but the failure to point out such errors or omissions shall not give the Contractor any right or claim nor shall in any way relieve the Contractor of obligations according to the terms of this Contract
  - 1. The Contractor's Surveyors instruments and other survey equipment shall be accurate, suitable for the surveys required in accordance with recognized professional standards and in proper operating condition and adjustment at all times. Surveys shall be performed under the direct supervision of a current Colorado Registered Licensed Surveyor.
- E. Field Notes:
  - 1. The Contractor shall record surveys in field notebooks or as electronic field notes, whichever is more appropriate to the type of survey work. Copies of the original pages of field notebooks shall be furnished to the DEN Project Manager and the DEN Survey Section at intervals required by the DEN Project Manager.

Each field notebook shall be furnished to the DEN Project Manager when filled or at completion of project. No erasures are allowed on the data entered in the field book. Cross out errors, and write correct entries above. The person that makes correction in the field book should initial above corrections made. An explanatory note shall be made for all corrections to original figures. All editing of computer records shall be done on a copy of the original with all changes initialed.

Electronic data from data collectors shall be provided in formats in accordance with DEN Design Standards Manual Volume 12 and Construction Plan Manual Technical Specifications Division 1. These will be used to supplement field books and shall be supplied to the DEN Project Manager and DEN Survey Section on Compact Disk (CD).

2. If the DEN Project Manager or DEN Survey Section finds errors in the field notes DEN will have the Contractor correct and resubmit the notes. This review does not relieve the Contractor from the responsibility of maintaining accurate survey data. Whichever method of note taking the Contractor starts with, the Contractor must use the same method throughout the Contract duration.

### 3.2 SUBSURFACE UTILITIES ENGINEERING (SUE)

- A. Refer to Section 011810 "Utilities Interface" for information related to underground utilities.

### 3.3 QUANTITY SURVEYS FOR PAYMENT

- A. When the specifications or the DEN Project Manager requires items in the Schedule of Prices and Quantities to be measured by surveying methods, the Contractor shall perform the surveys. All such surveys, including Horizontal and Vertical control surveys run for establishing the measurement values shall be performed in the presence of the DEN Project Manager and the DEN Surveyor may witness the surveying operation. The Contractor will reduce the field notes and calculate final quantities for payment purposes. The note reductions and calculations shall be submitted to the DEN Project Manager.

### 3.4 SURVEYING ACCURACIES AND TOLERANCES IN CONTROL SURVEYS, CONSTRUCTION LAYOUTS AND QUANTITY CALCULATIONS

- A. See CDOT Survey Manual or FAA Specifications for acceptable tolerances.

### 3.5 CAD DRAWINGS PER DEN GIS LAYER STANDARDS

- A. Where CAD drawings are required, follow DEN BIM DSM.

## **PART 4 - MEASUREMENT**

### 4.1 METHOD OF MEASUREMENT

- A. No separate measurement shall be made for work under this Section.

## **PART 5 - PAYMENT**

### 5.1 METHOD OF PAYMENT

- A. No separate payment will be made for work under this Section.



**PART 6 - Survey Checklist**

| Step | Yes                      | No                       | N/A                      | Project Kickoff Phase   |
|------|--------------------------|--------------------------|--------------------------|---|
| 1    | <input type="checkbox"/> | <input type="checkbox"/> | <input type="checkbox"/> | Did Consultant/Contractor meet with DEN PM obtain the data standards and general requirements for data gathering?   |
| 2    | <input type="checkbox"/> | <input type="checkbox"/> | <input type="checkbox"/> | Did Consultant/Contractor meet with Airport Survey Office to obtain airport survey control points, projection parameters, and airport survey training materials?    |
| 3    | <input type="checkbox"/> | <input type="checkbox"/> | <input type="checkbox"/> | Did Consultant/Contractor provide Survey Statement of Work to DEN PM?   |
| 4    | <input type="checkbox"/> | <input type="checkbox"/> | <input type="checkbox"/> | Did Consultant/Contractor provide Geodetic Verification Survey to DEN PM?   |
| 5    | <input type="checkbox"/> | <input type="checkbox"/> | <input type="checkbox"/> | Did Consultant/Contractor provide Survey Control Plan to DEN PM?  |
| 6    | <input type="checkbox"/> | <input type="checkbox"/> | <input type="checkbox"/> | Did Consultant/Contractor provide Imagery Plan to DEN PM? (Only required if collecting aerial imagery)?   |
| 7    | <input type="checkbox"/> | <input type="checkbox"/> | <input type="checkbox"/> | Did the FAA accept survey plans?  |
| Step | Yes                      | No                       | N/A                      | Construction Phase (As-Built)   |
| 8    | <input type="checkbox"/> | <input type="checkbox"/> | <input type="checkbox"/> | Did Consultant/Contractor perform field survey of project site to collect accurate as-built data?   |
| 9    | <input type="checkbox"/> | <input type="checkbox"/> | <input type="checkbox"/> | Did the Consultant/Contractor provide DEN PM with subsurface utility data?  |
| 10   | <input type="checkbox"/> | <input type="checkbox"/> | <input type="checkbox"/> | Each week, did the Consultant/Contractor provide DEN PM with Project Status Reports?  |
| 11   | <input type="checkbox"/> | <input type="checkbox"/> | <input type="checkbox"/> | Did the Consultant/Contractor provide DEN PM with 30% as-built data in both CADD and GIS formats including all attribute information and metadata?                  |
| 12a  | <input type="checkbox"/> | <input type="checkbox"/> | <input type="checkbox"/> | Did DEN PM report 30% QA findings via email to Consultant/Contractor?   |
| 12b  | <input type="checkbox"/> | <input type="checkbox"/> | <input type="checkbox"/> | If required, did the Consultant/Contractor provide DEN PM with 60% as-built data in both CADD and GIS formats including all attribute information and metadata?     |
| 12c  | <input type="checkbox"/> | <input type="checkbox"/> | <input type="checkbox"/> | If applicable, did DEN PM report 60% QA findings via email to Consultant/Contractor?  |
| 12d  | <input type="checkbox"/> | <input type="checkbox"/> | <input type="checkbox"/> | If required, did the Consultant/Contractor provide the DEN PM with 90% as-built data in both CADD and GIS formats including all attribute information and metadata? |
| 12e  | <input type="checkbox"/> | <input type="checkbox"/> | <input type="checkbox"/> | If applicable, did DEN PM report 90% QA findings via email to Consultant/Contractor?  |
| 13   | <input type="checkbox"/> | <input type="checkbox"/> | <input type="checkbox"/> | Did the Consultant/Contractor provide DEN PM with 100% as-built data in both CADD and GIS formats including all attribute information and metadata?                 |
| 14   | <input type="checkbox"/> | <input type="checkbox"/> | <input type="checkbox"/> | Did Consultant/Contractor provide DEN PM with a completed Final Survey Report?  |
| 15   | <input type="checkbox"/> | <input type="checkbox"/> | <input type="checkbox"/> | Did DEN PM report QA findings via email to Consultant/Contractor?   |

**PART 7 - SAMPLE OF A WEEKLY PROJECT STATUS REPORT:**

-----  
Anywhere Field/Anywhere International Airport

AIP X-XX-XXXX-XXX-20XX

Survey progress update #1

July XX to July XX

Eagle Eye Surveying completed a second week of ground surveying. The first week verified PACS and SACS control, collected runway centerline, and primary surface topographic information.

To date we have surveyed for Runway 12-30:  
Airport Control (PACS, SACS, ANY B540) 100%  
Runway and Stop way Ends 100%  
NAVAIDS (VOR, NDB, Airport Beacon, VASI, PAPI, and REILs) 100%  
Runway and Stop way Obstructions (Primary surface, approaches, transitional surfaces) 100%  
Aircraft Movement and apron areas 75%  
Prominent airport buildings / potential close-in obstructions 42%

This week we will be analyzing the collected obstruction survey data relative to the object identification surfaces. We will check both the required points for each obstruction zone and the navigational aids, and generate the appropriate field documentation. We completed subcontract negotiations with aerial photography sub consultant SkyCamera, Inc. and are submitting the proposed flight map with ground reference points for review and approval before completing our final week of field surveying. This week we will be setting aerial targets and surveying in the targets and Photo ID points, and collecting final outlying obstruction data. Aerial photography is promised to us 2 to 4 days after our targets are in place.

Sincerely,

Any Surveyor, P.S.  
Eagle Eye Surveying

-----  
**END OF SECTION 013223**

---

TECHNICAL SPECIFICATIONS  
01 GENERAL REQUIREMENTS  
013223  
CONSTRUCTION LAYOUT, AS-BUILT AND QUANTITY  
SURVEYS

---

DENVER INTERNATIONAL AIRPORT  
DEN TECH SPECS 2016  
CONTRACT NO.201737313

## SECTION 013233 - PHOTOGRAPHIC DOCUMENTATION

### PART 1 - GENERAL

#### 1.1 RELATED DOCUMENTS

- A. Drawings and general provisions of the Contract, including General and Special Conditions and other Division 01 Specification Sections, apply to this Section.

#### 1.2 SUMMARY

- A. Section includes administrative and procedural requirements for the following:
  1. Preconstruction photographs.
  2. Periodic construction photographs.
  3. Final Completion construction photographs.
  4. Preconstruction video recordings.
  5. Periodic construction video recordings.
  6. Web-based construction photographic documentation.

#### 1.3 REFERENCE DOCUMENTS:

- A. Section 013300 "Submittal Procedures"
- B. Section 017720 "Contract Closeout"
- C. Section 017900 "Demonstration and Training"
- D. Section 024116 "Structure Demolition"
- E. Section 024119 "Selective Demolition"
- F. Section 311000 "Site Clearing"

#### 1.4 ALTERNATES

- A. Refer to Section 012300 "Alternates"

#### 1.5 INFORMATIONAL SUBMITTALS

- A. Qualification Data: For **photographer**
- B. Key Plan: Submit key plan of Project site and building with notation of vantage points marked for location and direction of each **photograph**. Indicate elevation or story of

construction. Include same information as corresponding photographic documentation.

- C. Digital Photographs: Submit image files within **three (3)** days of taking photographs.
1. Digital Camera: Minimum sensor resolution of **10** megapixels.
  2. File Format: Minimum 3200 by 2400 pixels, in unaltered .RAW original files, with same aspect ratio as the sensor, uncropped, date and time stamped, in folder named by date of photograph, accompanied by key plan file.
  3. Identification: Provide the following information with each image description in file metadata tag:
    - a. Project title and Project number.
    - b. Name and contact information for photographer.
    - c. Name of DEN Project Manager.
    - d. Name of Contractor.
    - e. Date photograph was taken.
    - f. Description of vantage point, indicating location, direction (by compass point), and elevation or story of construction.
      - 1) Include work order number or change order number if applicable.
    - g. Unique sequential identifier keyed to accompanying key plan.
    - h. Photograph number.
- D. Construction Photographs: Submit **two (2)** prints of each photographic view within **seven (7)** days of taking photographs.
1. Format: **8-by-10-inch**. smooth-surface matte prints on single-weight, commercial-grade photographic paper; punched for standard three-ring binder.
  2. Identification: On back of each print, provide an applied label or rubber-stamped impression with the following information:
    - a. Name of Project.
    - b. Name and contact information for photographer.
    - c. Name of DEN Project Manager.
    - d. Name of Contractor.
    - e. Date photograph was taken if not date stamped by camera.
    - f. Description of vantage point, indicating location, direction (by compass point), and elevation or story of construction.
    - g. Unique sequential identifier keyed to accompanying key plan.
- E. Video Recordings: Submit video recordings within **seven (7)** days of recording.
1. Submit video recordings in an electronic format acceptable to DEN Project Manager. Recordings shall be high-resolution **4k** with a minimum framerate of 60Hz
  2. Identification: With each submittal, provide the following information:
    - a. Name of Project.
    - b. Name and address of photographer.

- c. Name of DEN Project Manager.
- d. Name of Contractor.
- e. Date video recording was recorded.
- f. Description and key plan of vantage point, indicating location, direction (by compass point), and elevation or story of construction.
- g. Weather conditions at time of recording.

## 1.6 QUALITY ASSURANCE

- A. Photographer Qualifications: An individual who has been regularly engaged as a professional photographer of construction projects for not less than three years.
- B. Web-Based Photographic Documentation Service Provider: A firm specializing in providing photographic equipment, Web-based software, and related services for construction projects, with record of providing satisfactory services similar to those required for Project for not less than three years.

## 1.7 USAGE RIGHTS

- A. Obtain and transfer copyright usage rights from photographer to City and County of Denver for unlimited reproduction of photographic documentation.

## PART 2 - PRODUCTS

### 2.1 PHOTOGRAPHIC MEDIA

- A. Digital Images: Provide images in JPG format, produced by a digital camera with minimum sensor size of **10** megapixels, and at an image resolution of not less than **3200 by 2400** pixels.
- B. Digital Video Recordings: Provide high-resolution **4k** with a minimum framerate of 60Hz in electronic format acceptable to DEN Project Manager.

## PART 3 - EXECUTION

### 3.1 CONSTRUCTION PHOTOGRAPHS

- A. Photographer: Engage a qualified photographer to take construction photographs.
- B. General: Take photographs using the maximum range of depth of field, and that are in focus, to show clearly the Work. Photographs with blurry or out-of-focus areas will not be accepted.
  - 1. Maintain key plan with each set of construction photographs that identifies each photographic location.

- C. Digital Images: Submit digital images exactly as originally recorded in the digital camera, without alteration, manipulation, editing, or modifications using image-editing software. Provide commercial quality, digital color photographs in PDF format. PDF file shall be security-free, bookmarked by date with all photos rotated to the correct orientation. Identify the following information on each photograph on the lower right corner.
1. Subject description (include work order number or change order number if applicable)
  2. Station point of camera and direction of view. Include letter size diagram of project indicating Station point
  3. Date and time each photo was taken
  4. Name of Contractor.
  5. Photograph number
  6. Field Office Images: Maintain one set of images accessible in the field office at Project site, available at all times for reference. Identify images in the same manner as those submitted to DEN Project Manager.
- D. Preconstruction Photographs: Before [**commencement of excavation**] [**commencement of demolition**] [**starting construction**], take photographs of Project site and surrounding properties, including existing items to remain during construction, from different vantage points, as directed by DEN Project Manager.
1. Flag [**excavation areas**] [**construction limits**] before taking construction photographs.
  2. Take [**20**] <Insert number> photographs to show existing conditions adjacent to property before starting the Work.
  3. Take [**20**] <Insert number> photographs of existing buildings either on or adjoining property to accurately record physical conditions at start of construction.
  4. Take additional photographs as required to record settlement or cracking of adjacent structures, pavements, and improvements.
  5. Haul route, laydown yard, and other locations as directed by DEN Project Manager.
- E. Periodic Construction Photographs: Take [**20**] <Insert number> photographs [**monthly, coinciding**] [**weekly, with timing each month adjusted to coincide**] <Insert time interval> with the cutoff date associated with each Application for Payment. Select vantage points to show status of construction and progress since last photographs were taken.
- F. DEN Project Manager-Directed Construction Photographs: From time to time, DEN Project Manager will instruct photographer about number and frequency of photographs and general directions on vantage points. Select actual vantage points and take photographs to show the status of construction and progress since last photographs were taken.
- G. Time-Lapse Sequence Construction Photographs: Take [**20**] <Insert number> photographs as indicated, to show status of construction and progress since last photographs were taken.

1. Frequency: Take photographs [**monthly, coinciding**] [**weekly, with timing each month adjusted to coincide**] <Insert time interval> with the cutoff date associated with each Application for Payment.
  2. Vantage Points: Following suggestions by DEN Project Manager and Contractor, photographer to select vantage points. During each of the following construction phases, take not less than [**two**] <Insert number> of the required shots from same vantage point each time to create a time-lapse sequence as follows:
    - a. Commencement of the Work, through completion of subgrade construction.
    - b. Above-grade structural framing.
    - c. Exterior building enclosure.
    - d. Interior Work, through date of Substantial Completion.
- H. Final Completion Construction Photographs: Take [**20**] <Insert number> color photographs after date of Substantial Completion for submission as project record documents. DEN Project Manager will inform photographer of desired vantage points.
1. Do not include date stamp.
- I. Additional Photographs: DEN Project Manager may request photographs in addition to periodic photographs specified. Additional photographs shall be paid for by Change Order and are not included in the Contract Sum.
1. Three days' notice shall be given, where feasible.
  2. In emergency situations, take additional photographs within 24 hours of request.
  3. Circumstances that could require additional photographs include, but are not limited to, the following:
    - a. Special events planned at Project site.
    - b. Immediate follow-up when on-site events result in construction damage or losses.
    - c. Photographs to be taken at fabrication locations away from Project site. These photographs are not subject to unit prices or unit-cost allowances.
    - d. Substantial Completion of a major phase or component of the Work.
    - e. Extra record photographs at time of final acceptance.
    - f. DEN's request for special publicity photographs.
- 3.2 CONSTRUCTION VIDEO RECORDINGS
- A. Video Recording Photographer: Engage a qualified videographer to record construction video recordings.
  - B. Recording: Mount camera on tripod before starting recording unless otherwise necessary to show area of construction. Display continuous running time and date. At start of each video recording, record weather conditions from local newspaper or television and the actual temperature reading at Project site.
  - C. Narration: Describe scenes on video recording by [**audio narration by microphone while**] [**dubbing audio narration off-site after**] video recording is recorded. Include



description of items being viewed, recent events, and planned activities. At each change in location, describe vantage point, location, direction (by compass point), and elevation or story of construction.

1. Confirm date and time at beginning and end of recording.
2. Begin each video recording with name of Project, Contractor's name, videographer's name, and Project location.

D. Preconstruction Video Recording: Before starting [**excavation**] [**demolition**] [**construction**], record video recording of Project site and surrounding properties from different vantage points, as directed by DEN Project Manager.

1. Flag [**excavation areas**] [**construction limits**] before recording construction video recordings.
2. Show existing conditions adjacent to Project site before starting the Work.
3. Show existing buildings either on or adjoining Project site to accurately record physical conditions at the start of [**excavation**] [**demolition**] [**construction**].
4. Show protection efforts by Contractor.

E. Periodic Construction Video Recordings: Record video recording [**monthly, coinciding**] [**weekly, with timing each month adjusted to coincide**] <Insert time interval> with the cutoff date associated with each Application for Payment. Select vantage points to show status of construction and progress since last video recordings were recorded. Minimum recording time shall be [**30**] <Insert number> minutes(s).

F. Time-Lapse Sequence Construction Video Recordings: Record video recording to show status of construction and progress.

1. Frequency: During each of the following construction phases, set up video recorder to automatically record one frame of video recording every [**five (5)**] <Insert time> minutes, from same vantage point each time, to create a time-lapse sequence of [**30 minutes**] <Insert time> in length as follows:
  - a. Commencement of the Work, through completion of subgrade construction.
  - b. Above-grade structural framing.
  - c. Exterior building enclosure.
2. Timer: Provide timer to automatically start and stop video recorder so recording occurs only during daylight construction work hours.
3. Vantage Points: Following suggestions by DEN Project Manager [**and Contractor**], photographer shall select vantage points.

### 3.3 WEB-BASED CONSTRUCTION PHOTOGRAPHIC DOCUMENTATION

- A. Live Streaming Construction Site Images: Provide Web-accessible image of current site image from [**fixed**] [**viewer-controlled**] location camera(s), updated at [**15**] <Insert number> minute intervals during daytime operation.
- B. Time-Lapse Sequence Construction Site Recordings: Provide video recording from a

fixed-location camera to show status of construction and progress.

1. Frequency: Record one frame of video recording every [15] <Insert number> minutes, from same vantage point each time, to create a time-lapse sequence of construction activities.
  2. Timer: Provide timer to automatically start and stop video recorder so recording occurs only during daylight construction work hours.
- C. Maintain cameras and Web-based access in good working order according to Web-based construction photographic documentation service provider's written instructions until Final Completion. Provide for service of cameras and related networking devices and software.

#### **PART 4 - MEASUREMENT**

##### 4.1 METHOD OF MEASUREMENT

- A. No separate measurement shall be made for work under this Section.

#### **PART 5 - PAYMENT**

##### 5.1 METHOD OF PAYMENT

- A. No separate payment will be made for work under this Section.

END OF SECTION **013233**



## SECTION 013300 - SUBMITTAL PROCEDURES

### PART 1 - GENERAL

#### 1.1 RELATED DOCUMENTS

- A. Drawings and general provisions of the Contract, including General and Special Conditions and other Division 01 Specification Sections, apply to this Section.

#### 1.2 SUMMARY

- A. The Work specified in this Section summarizes the requirements for the submittal of documents to the DEN Project Manager that are defined in these Specifications. It also describes the procedures for "supplemental" submittals.
- B. The Contractor must follow all the requirements of the procedures and the product details and keep all the submittals current and approved prior to any placement of work.

#### 1.3 SUBMITTAL SCHEDULE

- A. The Contractor shall provide a submittal schedule within 14 days after Notice to Proceed. The Submittal Schedule shall be directly related to the CPM schedule, shall identify all the submittals, and shall include the following information for each submittal item
  1. Specification section, Contract article, or special condition.
  2. Specification Subparagraph.
  3. Item description.
  4. Date the submittal shall be submitted.
  5. Name of subcontractor or supplier.
- B. The submittal schedule shall be kept current by the Contractor and submitted with the progress payment requests.
- C. For large files that cannot be loaded or e-mailed through the electronic Project Manager application (Unifier), submit the files on a CD, DVD, or USB flash drive media.

#### 1.4 ELECTRONIC SUBMITTALS

- A. Before the initiation of the submittal process, coordinate and insure that all submittals comply and follow the requirements of the DEN Building Information Modeling (BIM) Design Standards Manual (DSM) and the DEN BIM PXP.

- B. Submit request for progress payment applications utilizing TEXTURA software as instructed by DEN Project Manager.
- C. Submit Subcontractor's Contract information required by the City and County of Denver Small Business Office as instructed by DEN Project Manager.
- D. Submit original electronic copies of all City and County of Denver Development Department/ Building Inspection Department Approved drawings including all approvals of Deferred Submittals; including but not limited to shoring plans, Fire Protection distribution plans, and structural shop drawings to DEN Project Manager as Informational Submittals. The lack of approval of the Denver Development Services on any document shall be basis for rejection of Work and non-compliance.
  - 1. NOTE: Only original copies shall be accepted. Scans will not be accepted.
- E. Submit electronically scanned copies of all documents required by Chapter 17 "Special Inspection and Testing" of the International Building Code 2009 as amended by City and County of Denver 2011. Keep scale and clarify dimension where electronic copies are not as originally scaled and dimensioned.
- F. All submittals shall be delivered to the DEN Project Manager utilizing the Primavera Construction Manager program (PCM) as attachments and as separate file when files are too large to attach or of an electronic media that is not supported by PCM or Utilizing the EPPM Unifier software uploaded to the share drive Unifier's project site when directed by DEN Project Manager.
  - 1. Acceptable electronic formats
    - a. Print document format (pdf) shall have no security and bookmark every applicable submittal. All pages shall be completely legible and oriented to correct reading view.
  - 2. Formats are acceptable only with written permission of the DEN Project Manager or required by the BIM PXP. For files in any of the following formats, the corresponding stringency will apply:
    - a. Microsoft Office 2007 or newer. All files shall be fully compatible with Microsoft Office 2007.
      - 1) AutoCAD files shall be self-contained with no external x-references.
    - b. BIM files shall conform to the standards and formats outlined in the BIM PXP and DEN BIM DSM.
    - c. Other files pre-approved by the DEN Project Manager.

## 1.5 INITIAL SUBMITTAL

- A. Each submittal document shall include a title block showing the following information:
  - 1. Date of submittal and revision dates.

2. Contract title and number.
  3. The names of Contractor, subcontractor, supplier, manufacturer and when applicable, the seal and signature of an Engineer registered in the State of Colorado, for the involved discipline.
  4. Identification of product by either description, model number, style number or lot number.
  5. Subject identification by Contract Drawing or specification reference.
- B. On each submitted drawing, include a blank space on each sheet, three inches by four inches, in the lower right corner, just above the title block, in which the DEN Project Manager or the Designer of Record may indicate the action taken.
- C. Make submissions sufficiently in advance so that the DEN Project Manager Review may be completed not less than 30 days before Work represented by those submittals is scheduled to be performed.
- D. Allow a minimum cycle of 30 days for review of each submittal by the DEN Project Manager.
- E. Accompany submittal documents with DEN transmittal form CM-30, Submittal, which shall contain the following information:
1. Contractor's name, address and telephone number.
  2. Submittal number and date.
  3. Contract title and number.
  4. Supplier's, manufacturer's, or subcontractor's name, address and telephone number.
  5. Identification of variations from Contract Documents.
  6. Contractor's stamp and signature certifying the Contractor's review.
  7. Identification of submittal:
    - a. If the submittal is being made on a General Condition or Special Condition, reference the General or Special Condition number the first two digits of the specification section shall be 00XXXX.
    - b. If the submittal is being made under a specification section, reference the specification number, paragraph number, and subparagraph number.
    - c. If the submittal is being made under a drawing, reference the drawing(s) number and sub-number.
- F. The Contractor shall describe, at the time of submission, variations from the Contract documents in writing, separate from the submittal document. If the DEN Project Manager approves any such variations, an appropriate Contract change order shall be issued, except that if the variation is minor and does not involve a change in price or in time of performance, a modification need not be issued. If a submission contains variations and the variation column is not marked on the transmittal form, it will not be considered for review and acceptance. Along with marking the transmittal as a variation, a description must be included which outlines all the differences including maintenance and utility services along with any cost savings from an item not containing the variation.

- G. Changes in accepted submittal documents will not be permitted unless those changes have been accepted, in writing, by the DEN Project Manager.
- H. The form and quality of submittal documents shall comply with Section 013325 "Shop and Working Drawings, Product Data, and Samples."

#### 1.6 SUPPLEMENTAL SUBMITTALS

- A. Supplemental submittal documents initiated by the Contractor for consideration of corrective procedures shall contain sufficient data for review. Make supplemental submittals in the same manner as initial submittals with the appropriate primary transmittal referenced.

### **PART 2 - PRODUCTS (Not Used)**

### **PART 3 - EXECUTION**

#### 3.1 CONTRACTOR'S REVIEW

- A. The Contractor shall review all submittal documents, stamp, and sign as reviewed and approved as complying with Contract Documents prior to submission to the DEN Project Manager. Submittal documents that are submitted to the DEN Project Manager **THAT HAVE NOT BEEN REVIEWED BY THE CONTRACTOR** will not be reviewed and will be returned to the Contractor. Contractor is responsible for any delays in the Project due to improperly reviewed, stamped, and signed submittals.
- B. The Owner review period will be limited to ten (10) business days from the time complete submittal documents have been submitted.
- C. The Contractor is responsible to obtain all approvals for all deferred submittals, shop drawings, and significant changes from the CCD Development Service Department.
- D. All submittals must delineate any deviation from the intended design and must submit request for substitution to address any significant variation. Refer to Title 4, Article 405 – Shop Drawings, Product Data, and Samples, and Article 406 – Substitution of Materials and Equipment of the General Contract Conditions, 2011 Edition.

#### 3.2 REVIEW BY DEN PROJECT MANAGER

- A. Submittal documents will be reviewed by the DEN Project Manager, the DEN Project Manager Team, and/or the DOR for conformance to requirements of the Contract Documents. Review of a separate item will not constitute review of an assembly in which the item functions. The DEN Project Manager will withhold approval of submittals that depend on other submittals not yet submitted. Review and acceptance will not relieve the Contractor from the Contractor's responsibility for accuracy of submittals, for conformity of submittal document to requirements of Contract Drawings

and specifications, for compatibility of described product with contiguous products and the rest of the system, or for protection and completion of the Contract in accordance with the Contract Drawings and specifications.

- B. The City, the DOR, and/or the DEN Project Manager will review the submittal documents for general conformance with the Contract Documents and mark the Action Code, sign, and date the transmittal.
- C. The Action Codes have the following meanings:
  - 1. Accepted (ACC)
    - a. The submittal conforms to the respective requirements of the contract documents.
  - 2. Accepted as Noted (AAN)
    - a. The submittal conforms to the respective requirements of the Contract Documents after changes are made in accordance with reviewer's comments. AAN submittals do not need to be resubmitted.
  - 3. Revise and Resubmit (R&R)
    - a. The submittal is unacceptable and must be revised and resubmitted.
  - 4. Rejected (REJ)
    - a. The submittal is not approved and a new submittal in accordance with the Contract Documents must be prepared and submitted.
  - 5. For Information Only (FIO)
    - a. An item is received by the DEN Project Manager but is not reviewed.

### 3.3 CONTRACTOR'S RESPONSIBILITIES

- A. Coordinate each submittal document with the requirements of the Work. Place particular emphasis upon ensuring that each submittal of one trade is compatible with other submittals of that trade and submittals of other trades including producing as needed drawings showing the relationship of the Work of different trades.
- B. Contractor's responsibility for errors and omissions in submittal documents and associated calculations is not relieved by the DEN Project Manager's review, correction, and acceptance of submittals.
- C. Contractor's liability to the City, in case of variations in the submittal document from the requirements of the Contract Documents, is not relieved by the DEN Project Manager's review and acceptance of submittals containing variations unless the DEN Project Manager expressly approves the deviation in writing, in which the DEN Project Manager describes the variation.



- D. The Contractor shall maintain a file of all approved submittal documents at the work site. The complete file of approved submittal documents shall be turned over to the DEN Project Manager with the as-built documents at the end of the job.
- E. Schedule impact due to resubmittal requirements is the responsibility of the Contractor.

#### **PART 4 - MEASUREMENT**

##### 4.1 METHOD OF MEASUREMENT

- A. No separate measurement shall be made for work under this Section.

#### **PART 5 - PAYMENT**

##### 5.1 METHOD OF PAYMENT

- A. No separate payment will be made for work under this Section.

END OF SECTION **013300**

## SECTION 013325 - SHOP AND WORKING DRAWINGS, PRODUCT DATA, AND SAMPLES

### PART 1 - GENERAL

#### 1.1 RELATED DOCUMENTS

- A. Drawings and general provisions of the Contract, including General and Special Conditions and other Division 01 Specification Sections, apply to this Section.

#### 1.2 SUMMARY

- A. The Work specified in this Section consists of preparing and submitting shop and working drawings, product data, samples, and record documents required by other specifications Sections.
  - 1. The Contractor shall submit all shop drawings, working drawings, product data, and samples, as defined in the General Conditions, to the DEN Project Manager in accordance with the requirements in the technical specifications. The DEN Project Manager will return one (1) copy of the shop drawings, working drawings and product data to the Contractor with a written transmittal.
- B. The Contractor shall not submit as shop drawings, copies or reproductions of drawings issued to the Contractor by DEN.
- C. Related Requirements
  - 1. Section 013300 "Submittal Procedures
  - 2. Section 012510 "Substitutions"
  - 3. Section 017720 "Contract Closeout"

#### 1.3 SUBMITTALS

- A. All submittals shall be delivered to the DEN Project Manager in electronic format. All submittals must be of a consistent format (all PDF). No combination of electronic file types will be allowed unless required by a specific specification section.
  - 1. Acceptable electronic formats: Comply with the electronic file formats approved by DEN Building Information Modeling (BIM) Design Standards Manual If any of the files are in any of the formats listed below then the version of the software shall be no less than identified below:
    - a. Adobe Acrobat 8.0 or newer. All files shall be fully compatible with Adobe Acrobat 8.0.
    - b. Microsoft Office 2007 or newer. All files shall be fully compatible with Microsoft Office 2007.

- c. AutoDesk AutoCAD 2007 or newer. All files shall be fully compatible with AutoDesk AutoCAD 2007.
  - d. AutoCAD files shall be self-contained with no external x-references.
  - e. BIM format outlined in the BIM Project Execution Plan (PXP)
  - f. Other files pre-approved by the DEN Project Manager.
2. Adobe Acrobat Requirements:
- a. Drawings shall have security set to "No Security." Commenting, printing, adding photos, form fields and document signing must be allowed.
  - b. PDF submittals shall be one continuous file or Portfolio. No external links are allowed.
  - c. All individual components of submittals shall be bookmarked inside the PDF file.
  - d. All original documents shall be directly converted from the original electronic format to PDF. Scanning of files shall only be allowed by the DEN Project Manager when the original electronic information is not obtainable.
  - e. Failure to comply with these requirements will result in a return of file to the Contractor for immediate revision.
3. Electronic files submitted shall correspond with DEN File Control Numbering System available from the DEN Project Manager.

B. Quantities

1. One (1) electronic submittal in Unifier containing electronic files of each shop or working drawing.
2. One (1) electronic submittal in Unifier containing electronic files of manufacturer's standard schematic drawings.
3. One (1) electronic submittal in Unifier containing electronic files of manufacturer's calculations and manufacturer's standard data.
4. One (1) electronic submittal in Unifier containing electronic files of manufacturer's printed installation, erection, application, and placing instructions.
5. Nine (9) samples of each item specified in the various specification sections, unless otherwise specified.
6. One electronic submittal in Unifier containing electronic files of inspection, test reports, and certificates of compliance.
7. Note: If manufacturer's printed information is in color, all copies of submittals must be in color.

C. Review:

1. Submittal review comments by the DEN Project Manager will be in electronic form and incorporated into the electronic submittal file.
2. Resubmittals of electronic documents shall modify the original electronic file with new information and include the DEN Project Manager's comments with appropriate responses and additional information.

#### 1.4 CHANGES

- A. Changes in products for which shop or working drawings, product data or samples have been submitted will not be permitted unless those changes have been accepted and approved in writing by the Deputy Manager of Aviation as provided in Section 012510 "Substitutions."

#### 1.5 QUALITY CONTROL

- A. Shop drawings and record documents shall be prepared to the standards of quality outlined in the specifications, DSM and BIM PXP, prepared and printed from Revit and checked in the spatial coordination format specified in the BIM PXP.
- B. Refer to DEN BIM DSM for other requirements that may be applicable to this Article.

### **PART 2 - PRODUCTS.**

#### 2.1 SHOP AND WORKING DRAWINGS

- A. Prepare shop and working drawings in an electronic format that is current and approved by DEN to a scale large enough to easily depict and annotate each of the various items.
- B. Comply per other BIM requirements for Shop and Working Drawings as established in the DEN BIM DSM.
- C. Include the following as they apply to the subject:
  - 1. Contract title, work order, and number.
  - 2. Respective Contract drawing numbers.
  - 3. Applicable specification section numbers.
  - 4. Relation to adjacent structure or materials.
  - 5. Field dimensions clearly identified as such.
  - 6. Applicable standards such as ASTM or Federal Specification number, FAA, AASHTO, and pertinent authority specifications or standards.
  - 7. Identification of deviations from the Contract Drawings and specifications.
  - 8. Drawing name, number, and revision.
  - 9. Contractor's stamp, initialed or signed, certifying:
    - a. Verification of field measurements.
    - b. Review of submittals for compliance with Contract requirements.
    - c. Compatibility of the Work shown thereon with that of affected trades.
  - 10. Blank space on each sheet per Technical Specifications Section 013300 "Submittal Procedures."
- D. Drawings of equipment and other items that contain multiple parts shall include

exploded views showing the relationship of parts and the description of the parts into the smallest units that may be purchased or serviced.

- E. Comply with all submittal requirements of Section 013300 "Submittal Procedures."

## 2.2 PRODUCT DATA

- A. Modify manufacturer's standard and/or schematic drawings to delete information that is not applicable to the Contract. Supplement standard information with additional information applicable to this Contract.
- B. Modify manufacturer's standard(s), diagrams, schedules, performance charts, illustrations, calculations, and other descriptive data to delete information that is not applicable to the Contract. Indicate dimensions, clearances, performance characteristics, and capacities. Include with the submittal electrical, plumbing, HVAC, and any other diagrams, as applicable.
- C. Modify erection, application, and placing instructions to delete information that is not applicable to the Contract or work order.
- D. Include the following:
  - 1. Contract title, work order, and number.
  - 2. Respective Contract drawing numbers.
  - 3. Applicable Contract technical specification section numbers.
  - 4. Applicable standards such as ASTM or Federal Specification number, FAA, AASHTO and pertinent authority specifications or standards.
  - 5. Identification of deviations from the Contract Drawings and specifications.
  - 6. Contractor's stamp, initialed or signed, certifying:
    - a. Dimensional compatibility of the product with the space in which it is intended to be used.
    - b. Review of submittals for compliance with Contract requirements.
    - c. Compatibility of the product with other products with which it is to perform or which will be next to it.
    - d. The products electrical, plumbing, control and HVAC requirements conform to Contract Documents and the necessary utilities are provided for in the Contract Documents.
- E. Comply with all submittal requirements of Section 013300 "Submittal Procedures."

## 2.3 SAMPLES

- A. Submit samples of sizes and quantities to clearly illustrate full color range and functional characteristics of products and materials including attachment devices.
- B. Erect field samples and mockups at the work site as specified in specification Sections and at locations acceptable to the DEN Project Manager. All field samples shall be

erected in a location that will be readily visible throughout the life of the Contract to allow comparison of the Work as it progresses to the field sample. Field samples and mockups may be incorporated into the Work at Contractor's risk if approved by DEN Project Manager.

- C. The Contractor shall verify, through appropriate inspections and tests, that the samples submitted meet the specifications and shall provide inspection and test data with the samples. The review and comments on the sample shall not relieve the Contractor of the Contractor's responsibility for completion of the Contract.
- D. Show the following information:
  - 1. Contract title and number.
  - 2. Respective Contract drawing numbers.
  - 3. Applicable technical specification section numbers.
  - 4. Applicable standards such as ASTM or Federal Specification number.
  - 5. Identification of deviations from the Contract Drawings and specifications
  - 6. Contractor's stamp, initialed or signed, certifying:
    - a. Dimensional compatibility of the product with the space in which it is intended to be used
    - b. Review of submittals for compliance with Contract requirements
    - c. Compatibility of the product with other products with which it is to perform or which will be next to it
  - 7. If multiple samples are submitted and the DEN Project Manager is requested to make a choice, each sample shall have a unique identification number attached to it so the returned transmittal can state the identification number of the accepted sample and the Contractor will know which one it is.
- E. Comply with all submittal requirements of Section 013300 "Submittal Procedures."

### **PART 3 - EXECUTION**

#### **3.1 CONTRACTOR RESPONSIBILITIES**

- A. Verify field measurements, catalog numbers, and similar data.
- B. The Contractor shall not start work for which submittals are required until a transmittal has been received by the Contractor marked with the Action Code ACCEPTED or ACCEPTED AS NOTED by the DEN Project Manager.
- C. Before making submittals, ensure that the products will be available in the quantities and at the times required by the Contract.
- D. Submit final, corrected, electronic copies of Contract and shop and working drawings showing the Work as actually installed, placed, erected, and applied. Refer to Section 017720 "Contract Closeout."

### 3.2 REVIEW BY THE DEN PROJECT MANAGER

- A. One (1) electronic copy of the marked-up shop and working drawing and one (1) electronic copy of the product data will be returned to the Contractor by the DEN Project Manager. Only the transmittal form appropriately marked with the Action Code and comments, if any, will be returned on sample submittals.
- B. Contractor's responsibility for errors and omissions in submittals for compatibility will not be reduced, waived or otherwise limited by the review and acceptance of submittals by the DEN Project Manager.

## **PART 4 - MEASUREMENT**

### 4.1 METHOD OF MEASUREMENT

- A. No separate measurement shall be made for work under this Section.

## **PART 5 - PAYMENT**

### 5.1 METHOD OF PAYMENT

- A. No separate payment will be made for work under this Section. .

END OF SECTION **013325**

## **SECTION 013510 - CONSTRUCTION SAFETY**

### **PART 1 - GENERAL**

#### **1.1 RELATED DOCUMENTS**

- A. Drawings and general provisions of the Contract, including General and Special Conditions and other Division 01 Specification Sections, apply to this Section.

#### **1.2 SUMMARY**

- A. Work specified in this Section includes construction safety precautions and programs by the Contractor and the basis for reviews by the DEN Project Manager.
- B. For projects enrolled under DEN Rolling Owner Controlled Insurance Program (ROCIP) reference the Contract Special Conditions for all safety requirements.
- C. For projects enrolled under DEN Owner Controlled Insurance Program (OCIP) reference the Contract Special Conditions for all safety requirements.

#### **1.3 RESPONSIBILITY**

- A. The Contractor is responsible for the health and safety of the Contractor's personnel, agents, subcontractors and their personnel, and other persons on the worksite, for the protection and preservation of the Work and all materials and equipment to be incorporated therein, and for the worksite and the area surrounding the worksite. The Contractor shall take all necessary and reasonable precautions and actions to protect all such persons and property.
- B. This Section shall be interpreted in its broadest sense for the protection of persons and property by the Contractor and no action or omission by the DEN Project Manager or the DEN Project Manager's authorized representatives shall relieve the Contractor of any of its obligations and duties hereunder.

#### **1.4 SUBMITTALS**

- A. Refer to Section 013300 "Submittal Procedures" and Section 013325 "Shop and Working Drawings, Product Data and Samples" for the submittal process. The Contractor's Site Specific Safety Plan shall be submitted and approved under the general Contract prior to commencing any Work. If a Task Order or Change Order is issued where the Work is not covered by the approved Contractor's Site Specific Safety Plan, then a revision to the Safety Plan specific for the Work in the Task Order shall be resubmitted for approval.

1. No progress payment shall be approved until the Contractor's Site Specific



Safety Plan has been accepted by the DEN Project Manager.

- B. The Contractor shall provide six (6) copies of the Contractor's Site Specific Safety Plan to the DEN Project Manager for review at least ten (10) calendar days before on-site construction begins. The Contractor's program must meet, as a minimum, all applicable federal, state and local government requirements, and the following:
1. The Contractor shall provide the following information for acceptance by the DEN Project Manager prior to the commencement of construction activities. The Site Specific Safety Plan must address all aspects listed below. If an item is not applicable, then this must be noted in the plan.
    - a. Name of the Contractor's safety representative.
    - b. If the Contractor is running multiple shifts or working more than (40) hours per week, the name of an assistant safety representative who can act in the absence of the site safety representative.
    - c. Twenty-four (24) hours per day emergency phone numbers of Contractor site management to be used in case of injury or accident. Provide at least four contacts.
    - d. Means of protecting employees working in trenches and excavations, including sloping and shielding.
      - 1) Soil classification will be considered as Type C when designing protective systems, unless the Contractor can prove to the satisfaction of DEN that the soil classification is otherwise. Soil classification change request shall be provided to the DEN Project Manager in writing. The decision of the DEN Project Manager will be provided to the Contractor in writing.
    - e. The Contractor shall show how material shall be stored beside the excavation. Stored material shall include the excavated and backfilled material
    - f. Injury and accident handling, including samples of the reporting form.
    - g. How personnel will be handled who are unable to safely perform their duties, including how the Contractor will determine whether personnel are unable to safely perform duties. This may include the Contractor's disciplinary process and employee's physical capabilities to perform the work safely.
    - h. How and when equipment will be checked to see that it is safe, that all safety guards are in place, and that the equipment is being used for its designed purpose and within its rated capacity.
    - i. How and when all electric devices will be checked for proper grounding and insulation. Describe the methods that will be used to lock out electric systems that should not be energized.
    - j. How trash and human organic waste will be disposed of.
    - k. How snow and ice will be removed by the Contractor in the project area.
    - l. How concrete forms will be anchored to ensure their stability, including calculations showing that the forms will safely hold the maximum construction loads.
    - m. How flammable materials will be stored and handled, and how any spills will

- be cleaned up and removed for disposal.
- n. What system will be used to prevent fires and, if fires do occur, who will be trained to fight them. In addition, what firefighting equipment will the Contractor have available and how will this equipment's condition be monitored.
  - o. How materials will be received, unloaded, stored, moved, and disposed of.
  - p. How personnel working above ground level will be protected from falling.
  - q. How people working beneath the construction work will be protected.
  - r. What will be done to protect personnel in case of severe weather.
  - s. How adequate lighting will be provided and monitored.
  - t. How air quality will be monitored to ensure that chemical exposures are below current, established OSHA Permissible Exposure Limits. How personnel will be protected if these limits are exceeded.
  - u. How the safety of work platforms, man lifts, material lifts, ladders, shoring, scaffolding, etc., will be ensured relating to load capacity and the protection of personnel using or working around them.
  - v. The type of personal protective equipment that will be used to protect personnel from hazards.
  - w. The type of safety training that will be provided to personnel to inform them of safe work procedures.
  - x. How daily audits and inspections will be performed to ensure compliance with the Contractor's Site Specific Safety Plan and current, applicable OSHA regulations.
  - y. Procedures to ensure that welding and other hot work is performed safely.
    - 1) A hot work permit from the Denver Fire Department (DFD) will be required for all welding, soldering, cutting, and brazing and or other processes required by DFD on the project. Contractor will comply with all of the provisions in the permit.
  - z. How compressed gases will be safely stored, handled, and used.
  - aa. Methods to ensure that personnel safely enter, work in, and exit confined spaces.
    - 1) All confined spaces on DEN property are considered permit required. A permit must be obtained from the DFD before Contractor personnel may enter a confined space. Contractors will comply with all provisions and requirements of this permit.
  - bb. How the hazards of chemicals will be communicated to personnel, including the use of material safety data sheets and chemical labels.
  - cc. Methods to ensure that forklifts and other powered industrial trucks are operated in a safe manner.
  - dd. How an effective hearing conservation program will be used to protect personnel from high noise levels and prevent hearing loss.
  - ee. How personnel will be protected from the effects of jet blast.
  - ff. How hazards will be identified and corrected when reported.

## 1.5 DEN PROJECT MANAGER'S REVIEW

- A. Prior to the start of any work by contractor or subcontractor personnel, the Contractor shall provide the DEN Project Manager with a list of its personnel, subcontractor's personnel and other personnel the Contractor has requested to work at Denver International Airport, who have signified in writing that they have been briefed on, or have read and understand, the Contractor's Site Specific Safety Plan.

## PART 2 - PRODUCTS (NOT USED)

## PART 3 - EXECUTION

### 3.1 IMPLEMENT CONTRACTOR'S OPERATIONAL SAFETY PLAN

- A. Implement the approved Contractor's Operational Safety Plan as described in Article 1 of this Section and in Section 011100 "Summary of Work."
- B. If the Contractor experiences lost time or an injury rate greater than 75 percent of the national average for all construction, the Contractor shall notify the DEN Project Manager and audit its safety procedures and submit a plan to reduce its rates.
- C. If at any time the lost time or injury rates experienced by the Contractor are 150 percent or more of the national average for construction, the Contractor shall notify the DEN Project Manager and immediately hire an independent safety professional who shall audit the Contractor's procedures and operations and make a report of changes that the Contractor should implement to reduce the rate including changing personnel.
  - 1. The report shall be submitted to the DEN Project Manager.
  - 2. The Contractor shall immediately begin implementing the recommendations of the independent safety professional.
  - 3. A weekly report shall be submitted by the Contractor to the DEN Project Manager on the status of the implementation of the recommendations.
  - 4. Failure to comply with these requirements is a basis to withhold a portion of progress payments.

### 3.2 ROLLING OWNER CONTROLLED INSURANCE PROGRAM (ROCIP)

- A. Implement Rolling Owner Controlled Insurance Program (ROCIP) as provided in the Project Manual issued for bid or proposal

### 3.3 OWNER CONTROLLED INSURANCE PROGRAM (OCIP)

- A. Implement Owner Controlled Insurance Program (OCIP) as provided in the Project Manual issued for bid or proposal

## **PART 4 - MEASUREMENT**

### 4.1 METHOD OF MEASUREMENT

- A. No separate measurement shall be made for work under this Section.

## **PART 5 - PAYMENT**

### 5.1 METHOD OF PAYMENT

- A. No separate payment will be made for work under this Section.

END OF SECTION 013510



## **SECTION 013520 - CONSTRUCTION SAFETY - AIRSIDE**

### **PART 1 - GENERAL**

#### **1.1 RELATED DOCUMENTS**

- A. Drawings and general provisions of the Contract, including General and Special Conditions and other Division 01 Specification Sections, apply to this Section.

#### **1.2 SUMMARY**

- A. Work specified in this Section includes construction safety precautions and programs by the Contractor for airside, and the basis for reviews by the DEN Project Manager.
- B. Related Specification Sections:
  - 1. Section 011420 "Security Requirements and Sensitive Security Information".
  - 2. Section 011430 "Vehicle and Equipment Permitting".
  - 3. Section 011810 "Utilities Interface".
  - 4. Section 013510 "Construction Safety".
- C. For projects enrolled under DEN Rolling Owner Controlled Insurance Program (ROCIP) reference the Contract Special Conditions for all safety requirements.
- D. For projects enrolled under DEN Owner Controlled Insurance Program (OCIP) reference the Contract Special Conditions for all safety requirements.

#### **1.3 RESPONSIBILITY**

- A. The Contractor is responsible for the health and safety of the Contractor's personnel, agents, subcontractors and their personnel, and other persons on the worksite, for the protection and preservation of the Work and all materials and equipment to be incorporated therein, and for the worksite and the area surrounding the worksite. The Contractor shall take all necessary and reasonable precautions and actions to protect all such persons and property.
- B. This Section shall be interpreted in its broadest sense for the protection of persons and property by the Contractor and no action or omission by the DEN Project Manager or the DEN Project Manager's authorized representatives shall relieve the Contractor of any of its obligations and duties hereunder.

#### **1.4 SUBMITTALS**

- A. Refer to Section 013300 "Submittal Procedures" and Section 013325 "Shop and Working Drawings, Product Data and Samples" for the submittal process. The

Contractor's Operational Safety Plan shall be submitted and approved under the general Contract prior to commencing any Work. If a Task Order or Change Order is issued where the Work is not covered by the approved Contractor's Operational Safety Plan, then a revision to the Safety Plan specific for the Work in the Task Order shall be resubmitted for approval.

1. No progress payment shall be approved until the Contractor's Operational Safety Plan has been accepted by the DEN Project Manager.
- B. Scope: The Contractor's Operational Safety Plan shall be developed and submitted by the contractor for the DEN Project Manager's review and approval. The Operational Safety Plan shall be developed according to the guidelines and requirements provided in FAA AC No. 150/5370-2F "Operational Safety on Airports During Construction" and will describe how the Contractor will comply with the requirements of the Construction Safety and Phasing Plan (CSPP). The Operational Safety Plan shall cover the actions of not only the construction personnel and equipment, but the actions of inspection personnel and airport staff for the duration of construction activities.
- C. Definitions:
1. Approach Surface: A surface longitudinally centered on the extended runway centerline and extending outward and upward from either a runway threshold or 200 feet behind a threshold. This surface is needed to define where unobstructed airspace above the runway begins.
  2. Notice To Airmen (NOTAM): A notice to the flying public (airmen) through FAA's NOTAM system. Normally initiated by message to the nearest FAA Flight Service Station. Issuance of the NOTAM will be coordinated through the DEN Project Manager and DEN Operations.
  3. Object Free Area: A two-dimensional ground area surrounding runways, taxiways, and taxi lanes that is clear of objects, except for objects whose location is fixed by function.
  4. Safety Area (see AC 150/5300-13A): A defined surface adjacent to runways, taxiways and taxi lanes prepared or suitable for reducing the risk of damage to aircraft in the event of an undershoot, overshoot or excursion from the paved surface. Each safety area must be cleared and graded and have no potentially hazardous ruts, humps, depressions or other surface variations. Each safety area must be drained by grading or storm sewers to prevent water accumulation. East safety area must be capable under dry conditions of supporting snow removal and aircraft rescue and firefighting equipment and or supporting the occasional passage of aircraft without causing any damage to the aircraft. No objects may be located in any safety area, except for objects that need to be located in a safety area because of their function. These objects must be constructed, to the extent practical, on frangibly mounted structures of the lowest practical height, with the frangible point no higher than three (3) inches above grade.
- D. Policy: Aviation safety is a primary consideration during airport construction. These activities shall be planned and scheduled to minimize disruption of normal aircraft activities. If the clearances and restrictions described in this plan cannot be maintained while construction is underway, action will be taken by the Contractor to perform Work

at night or during periods of minimal aircraft activity.

E. Safety Impacts: The Contractor shall take all necessary steps and precautions to mitigate the impact of hazardous conditions as they may relate to the Work. Potentially hazardous conditions which may occur during airport construction include, but are not limited to, the following:

1. Trenches, holes, or excavations on or adjacent to any active runway, taxiway, taxi lane, apron, or related safety areas.
2. Unmarked/unlighted holes or excavations on or adjacent to any active runway, taxiway, taxi lane, apron, or related safety areas.
3. Mounds or piles of earth, construction material, temporary structures, or other objects on or in the vicinity of any active runway, taxiway, taxi lane, apron or related safety, approach, or departure areas.
4. Pavement drop-offs that would cause, if crossed at normal operating speeds, damage to aircraft that normally use the airport. The maximum drop-off is 3 inches per FAA AC 150/5300-13A.
5. Vehicles or equipment (whether operating or idle) on any active runway, taxiway, taxi lane, apron or related safety, approach, or departure areas.
6. Vehicles, equipment, excavations, stockpiles, or other materials that could impinge upon NAVAID-critical areas and degrade or otherwise interfere with electronic NAVAIDS or interfere with visual NAVAIDS facilities.
7. Unmarked utility, NAVAIDS, weather service, runway lighting, underground power, or signal cables that could be damaged during construction.
8. Objects or activities anywhere on or in the vicinity of an airport which would be distracting, confusing, or alarming to pilots during aircraft operations.
9. Unflagged/unlighted low visibility items such as tall cranes, backhoes, scrapers, dump trucks, rollers, compactors, dozers and the ilk, in the vicinity of an active runway, taxiway, taxi lane, apron or related safety, approach, or departure areas.
10. Dirt, debris, or other transient accumulations that temporarily obscure pavement markings or pavement edges, or derogate the visibility of runway or taxiway markings or lighting or of construction and maintenance areas.
11. Trash or other materials with foreign object damage (FOD) potential, whether on runways, taxiways, taxi lanes, aprons or in related safety areas.
12. Failure to control vehicle, human and large animal access to, and nonessential nonaeronautical activities on, open aircraft movement areas.
13. Failure to maintain radio communication between construction vehicles and air traffic control or other on-field communications facilities.
14. Construction activities or material which could hamper Aircraft Rescue and Fire Fighting (ARFF) vehicle access from ARFF stations to all parts of the runway/taxiway system, runway approach and departure areas, or aircraft parking locations.
15. Inadequate fencing or other marking to separate construction areas from open aircraft operating areas.
16. Bird attractions such as edibles (food scraps, etc.), trees, brush, other trash, grass/crop seeding, or ponded water on or near the airport.

F. Safety Requirements:

1. General:



- a. During performance of this Contract, the airport runways, taxiways, taxi lanes, and aircraft parking aprons shall remain in use by aircraft to the maximum extent possible, consistent with continual safety. Aircraft use of areas near the Contractor's Work will be controlled to minimize disturbance to the Contractor's operation. However, AIRCRAFT HAVE THE RIGHT OF WAY AT ALL TIMES. The Contractor shall not allow employees, subcontractors, suppliers, or any unauthorized persons to enter or remain in any airport area that would be hazardous to persons or to aircraft operations.
  - b. Contractor personnel, airport staff and field inspectors directly involved in on-airport construction shall:
    - 1) Be aware of the types of conditions, safety problems, and/or hazards identified each day at the airport. To insure that all personnel are aware, daily meetings between management and supervisory personnel and their employees shall be scheduled prior to any work commencing on the shift.
    - 2) Inspect daily all work and/or storage areas for which the Contractor is responsible to be aware of current conditions.
    - 3) Promptly take all steps needed to remedy any unsafe or potentially unsafe condition. Coordinate with the DEN Project Manager to insure immediate corrective action is undertaken
  - c. Before commencement of construction activity the Contractor, through coordination with the DEN Project Manager and DEN Operations, shall give notice using the NOTAM system of construction on the airfield. In addition, a NOTAM shall be issued for the completion of construction on the airfield.
2. Construction Area Marking: Temporary lighting, barricades, flagging, and flashers are required as shown on the plans and per FAA AC 150/5370-2F Chapter 2 Section 220.b.(1)(2) Flag lines, traffic cones, flashers, edge lights, and/or signs shall be used as necessary:
- a. To clearly separate all construction from other parts of an air operations area
  - b. To identify isolated hazards, such as open manholes, excavations, areas under repair, stockpiled material, waste areas, etc.
  - c. Vehicle and pedestrian access routes used for airport construction shall be controlled to prevent any unauthorized entry of persons, vehicles, or animals.
  - d. Vehicle parking areas for Contractor employees shall be designated in advance to minimize traffic in open/active aircraft movement areas.
3. Cables and Utilities:
- a. Special attention shall be given to preventing unscheduled interruption of utility services and facilities. The location of all cables and utilities shall be identified prior to construction activities.
  - b. There shall be coordination among the Contractor, the DEN Project Manager, DEN Operations, the FAA, the National Weather Service, utility

- companies, and any other appropriate entity or organization. NAVAIDS, weather service facilities, electric cables, and other utilities must be fully protected during the entire construction time.
- c. Power, communication, and control cables leading to and from any FAA NAVAIDS, weather service, and other facilities will be marked in the field by the appropriate individuals as identified in Section 011810 "Utilities Interface" for the information of the Contractor before any work in their general vicinity is started. Thereafter, through the entire duration of construction, utilities shall be protected from any possible damage.
  - d. At the intersection of expansion joints and centerline lighting circuits on taxiways and runways, the electrical conduit may be within the 21" portion of the Portland cement concrete pavement. Coordination with the DEN Project Manager's representative and the DEN Electrical Department is of utmost importance for both the scheduling of an outage and the removal of conductors while cutting the joint.
4. Vehicle and Employee Identification:
- a. Contractor vehicles and equipment shall be flagged for high daytime visibility and if appropriate, lighted for nighttime operations. Vehicles that are not marked and lighted shall be escorted by a vehicle that is equipped with appropriate marking and lighting devices. Marking and lighting shall be in conformance with FAA AC 150/5210-5D, current edition, or as outlined in Section 011430 "Vehicle and Equipment Permitting" of the Contract Documents.
  - b. The Contractor will be required to conform to the specific requirements as outlined in Section 011420 "Security Requirements and Sensitive Security Information (SSI)" of the Contract documents.
5. Radio Communications:
- a. The Contractor's construction superintendent and flag personnel shall be required to coordinate directly with the DEN Project Manager or designated Representative. Only the DEN Project Manager or designated Representative shall monitor transceiver radios tuned to the frequency for communications with DEN Operations and B Tower Control. Radios shall be used to obtain the proper clearance concerning the movement of equipment, trucks, etc., on the airfield. Further, any unusual occurrences in the flight pattern of approaching or departing aircraft shall be acknowledged by all concerned so that operation of the airport and the construction work can be safely carried on at all times.
6. Haul Routes Crossing Active Aircraft Operation Areas:
- a. The Contractor shall provide a minimum of one (1) broom truck to continuously clean the surface of the active taxiway, taxi lane or apron of any foreign object damage (FOD) or other objectionable debris that may result from hauling activities. Additional broom trucks may be required to expedite the cleanup process. Opening the taxiway, taxi lane, or apron to aircraft operations shall only be approved after a visual inspection of the

- pavement surface by the DEN Airfield Operations Manager.
- b. The Contractor shall not work within the minimum of the following: 160 ft. of the centerline of an active taxiway, 310 ft. of the centerline of an active runway, or the minimum requirements of the FOD or Safety Zone unless otherwise noted in the Contract Documents and as approved in writing by the DEN Project Manager.
  - c. All construction equipment and vehicles shall be flagged for high daytime visibility and if appropriate, lighted for nighttime operations. Vehicles that are not marked and lighted shall be escorted by a vehicle that is equipped with appropriate marking and lighting devices. Marking and lighting shall be in conformance with FAA AC 150/5210-5D, current edition.
  - d. All Contractor and Subcontractor employees must be aware of the types of safety problems and hazards associated with aircraft operations and construction activities.

## PART 2 - PRODUCTS

### 2.1 Contractor's Operational Safety Plan

- A. The Contractor shall provide six (6) copies of the Contractor's Operational Safety Plan to the DEN Project Manager for review at least ten (10) calendar days before on-site construction begins. The Contractor's program must meet, as a minimum, all applicable federal, state and local government requirements, and the following:
  1. The Contractor shall provide the following information for acceptance by the DEN Project Manager prior to the commencement of construction activities. The Operational Safety Plan must address all aspects listed below. If an item is not applicable, then this must be noted in the plan.
    - a. Name of the Contractor's safety representative.
    - b. If the Contractor is running multiple shifts or working more than (40) hours per week, the name of an assistant safety representative who can act in the absence of the site safety representative.
    - c. Twenty-four (24) hours per day emergency phone numbers of Contractor site management to be used in case of injury or accident. Provide at least four contacts.
    - d. Means of protecting employees working in trenches and excavations, including sloping and shielding.
      - 1) Soil classification will be considered as Type C when designing protective systems, unless the Contractor can prove to the satisfaction of DEN that the soil classification is otherwise. Soil classification change request shall be provided to the DEN Project Manager in writing. The decision of the DEN Project Manager will be provided to the Contractor in writing.
    - e. The Contractor shall show how material shall be stored beside the excavation. Stored material shall include the excavated and backfilled

- material
- f. Injury and accident handling, including samples of the reporting form.
  - g. How personnel will be handled who are unable to safely perform their duties, including how the Contractor will determine whether personnel are unable to safely perform duties. This may include the Contractor's disciplinary process and employee's physical capabilities to perform the work safely.
  - h. How and when equipment will be checked to see that it is safe, that all safety guards are in place, and that the equipment is being used for its designed purpose and within its rated capacity.
  - i. How and when all electric devices will be checked for proper grounding and insulation. Describe the methods that will be used to lock out electric systems that should not be energized.
  - j. How trash and human organic waste will be disposed of.
  - k. How snow and ice will be removed by the Contractor in the project area.
  - l. How concrete forms will be anchored to ensure their stability, including calculations showing that the forms will safely hold the maximum construction loads.
  - m. How flammable materials will be stored and handled, and how any spills will be cleaned up and removed for disposal.
  - n. What system will be used to prevent fires and, if fires do occur, who will be trained to fight them. In addition, what firefighting equipment will the Contractor have available and how will this equipment's condition be monitored.
  - o. How materials will be received, unloaded, stored, moved, and disposed of.
  - p. How personnel working above ground level will be protected from falling.
  - q. How people working beneath the construction work will be protected.
  - r. What will be done to protect personnel in case of severe weather.
  - s. How adequate lighting will be provided and monitored.
  - t. How air quality will be monitored to ensure that chemical exposures are below current, established OSHA Permissible Exposure Limits. How personnel will be protected if these limits are exceeded.
  - u. How the safety of work platforms, man lifts, material lifts, ladders, shoring, scaffolding, etc., will be ensured relating to load capacity and the protection of personnel using or working around them.
  - v. The type of personal protective equipment that will be used to protect personnel from hazards.
  - w. The type of safety training that will be provided to personnel to inform them of safe work procedures.
  - x. How daily audits and inspections will be performed to ensure compliance with the Contractor's Operational Safety Plan and current, applicable OSHA regulations.
  - y. Procedures to ensure that welding and other hot work is performed safely.
    - 1) A hot work permit from the Denver Fire Department (DFD) will be required for all welding, soldering, cutting, and brazing and or other processes required by DFD on the project. Contractor will comply with all of the provisions in the permit.
  - z. How compressed gases will be safely stored, handled, and used.

- aa. Methods to ensure that personnel safely enter, work in, and exit confined spaces.
  - 1) All confined spaces on DEN property are considered permit required. A permit must be obtained from the DFD before Contractor personnel may enter a confined space. Contractors will comply with all provisions and requirements of this permit.
- bb. How the hazards of chemicals will be communicated to personnel, including the use of material safety data sheets and chemical labels.
- cc. Methods to ensure that forklifts and other powered industrial trucks are operated in a safe manner.
- dd. How an effective hearing conservation program will be used to protect personnel from high noise levels and prevent hearing loss.
- ee. How personnel will be protected from the effects of jet blast.
- ff. How hazards will be identified and corrected when reported.

## 2.2 DEN PROJECT MANAGER'S REVIEW

- A. Prior to the start of any work by contractor or subcontractor personnel, the Contractor shall provide the DEN Project Manager with a list of its personnel, subcontractor's personnel and other personnel the Contractor has requested to work at Denver International Airport, who have signified in writing that they have been briefed on, or have read and understand, the Contractor's Operational Safety Plan.

## PART 3 - EXECUTION

### 3.1 IMPLEMENT CONTRACTOR'S OPERATIONAL SAFETY PLAN

- A. Implement the approved Contractor's Operational Safety Plan as described in Part 1 and Part 2 of this Section and in Section 011100 "Summary of Work."
- B. If the Contractor experiences lost time or an injury rate greater than 75 percent of the national average for all construction, the Contractor shall notify the DEN Project Manager, audit its safety procedures, and submit a plan to reduce its rates.
- C. If at any time the lost time or injury rates experienced by the Contractor are 150 percent or more of the national average for construction, the Contractor shall notify the DEN Project Manager and immediately hire an independent safety professional who shall audit the Contractor's procedures and operations and make a report of changes that the Contractor should implement to reduce the rate including changing personnel.
  - 1. The report shall be submitted to the DEN Project Manager.
  - 2. The Contractor shall immediately begin implementing the recommendations of the independent safety professional.
  - 3. A weekly report shall be submitted by the Contractor to the DEN Project Manager on the status of the implementation of the recommendations.
  - 4. Failure to comply with these requirements is a basis to withhold a portion of

progress payments.

3.2 ROLLING OWNER CONTROLLED INSURANCE PROGRAM (ROCIP)

- A. Implement Rolling Owner Controlled Insurance Program (ROCIP) as provided in the Project Manual issued for bid or proposal

3.3 OWNER CONTROLLED INSURANCE PROGRAM (OCIP)

- A. Implement Owner Controlled Insurance Program (OCIP) as provided in the Project Manual issued for bid or proposal

**PART 4 - MEASUREMENT**

4.1 METHOD OF MEASUREMENT

- A. No separate measurement shall be made for work under this Section.

**PART 5 - PAYMENT**

5.1 METHOD OF PAYMENT

- A. No separate payment will be made for work under this Section.

END OF SECTION **013520**



## **SECTION 014100 - REGULATORY REQUIREMENTS**

### **PART 1 - GENERAL**

#### **1.1 RELATED DOCUMENTS**

- A. Drawings and general provisions of the Contract, including General and Special Conditions and other Division 01 Specification Sections, apply to this Section.

#### **1.2 SUMMARY**

- A. This Section identifies primary compliance with the State, City and County of Denver's regulatory requirements including:
  - 1. City and County of Denver / Department of Aviation.
  - 2. Colorado Department of Public Health and Environment.
  - 3. City and County of Denver Development Services, including the Department of Public Works and Division of Wastewater Management.
  - 4. The standards that govern design and construction projects at Denver International Airport.
- B. Construction shall be based on the latest edition of the referenced codes including additions and revisions thereto that are in effect at the time of Project bidding or Task Order pricing or GMP established whichever is latest, and as specifically related.

#### **1.3 RELATED SECTIONS**

- 1. Section 015719 "Temporary Environmental Controls" for environmental and related permitting requirements.

#### **1.4 BUILDING CODE**

- A. All design and construction work shall be governed by the Building Code for the City and County of Denver, latest edition. This is based upon the International Building Code of the International Code Council with Denver Amendments to this code. Appendix N of the Denver Amendments addresses Construction of Airport Buildings and Structures.

- 1. This Contract shall be based on IBC 2009 as Amended by Denver dated 2011.

#### **1.5 DENVER BUILDING DEPARTMENT**

- A. For review and approval of all construction documents for compliance to the Denver building code:



City and County of Denver  
Denver Development Services  
201 West Colfax Avenue, Dept 205  
Denver, Colorado 80202  
Telephone 720-865-2790  
Fax 720-865-3020  
developmentservices@denvergov.org

## 1.6 DENVER FIRE DEPARTMENT

- A. For review and approval of plans for compliance with the Denver Fire Department's requirements as they apply to the Denver International Airport:

Denver Fire Department  
745 West Colfax Avenue  
Denver, Colorado 80204  
Telephone 720-913-3474

- B. The Contractor is advised that the Denver Fire Department – Fire Prevention Bureau requires permitting for the following activities as they apply to the scope of work. The Contractor is responsible for obtaining the appropriate permits necessary to complete the work. All costs associated with this permitting and policy compliance shall be the responsibility of the Contractor. The policies all reference the International Fire Code (IFC).

1. “Hot work”, which is defined as the operation of any equipment or tool that creates sparks, hot slag, or radiant or convective heat as a result of the work. This includes, but is not limited to, welding, cutting, brazing, or soldering.
2. Use and storage of compressed gas for both temporary storage and permanent facility installation. This includes, but is not limited to, flammable gas (excluding propane-LPG), oxidizer (including oxygen), and inert and/or simple asphyxiates.
3. Tank installation, which includes aboveground storage tanks (AST) and underground storage tanks (UST) for both temporary tanks and permanent facility installations.

- C. In addition to the above permits, the Denver Fire Department may require other permits that are associated with the specific work in the Contract Documents. Policies provided by the Denver Fire Department are meant to provide basic information for the most common conditions and situations. In any given occupancy, many other Uniform Fire Code requirements may be enforced. These should be addressed with the Denver Fire Department before construction begins and during construction with premise inspection(s).

1. The Fire Prevention Bureau web site is [denfpb@denvergov.org](mailto:denfpb@denvergov.org)

## **PART 2 - PRODUCTS (Not Used)**

## **PART 3 - EXECUTION**

### **3.1 PERMITS AND CERTIFICATIONS**

- A. The Contractor shall maintain records on site of all permits acquired by federal, state, and local agencies. Posting of permits shall conform to requirements of the respective agencies.
- B. At the completion of any inspection by other agencies, the Contractor shall forward copies of the status of the inspection and copies of any approved or "signed-off" inspections by the respective agencies to the DEN Project Manager.
- C. At the time of request for Substantial Completion, the Contractor shall forward to the DEN Project Manager all permits approved by the respective agencies.

## **PART 4 - MEASUREMENT**

### **4.1 METHOD OF MEASUREMENT**

- A. No separate measurement shall be made for work under this Section.

## **PART 5 - PAYMENT**

### **5.1 METHOD OF PAYMENT**

- A. No separate payment will be made for work under this Section.

**END OF SECTION 014100**



## SECTION 014210 - REFERENCED MATERIAL

### PART 1 - GENERAL

#### 1.1 RELATED DOCUMENTS

- A. Drawings and general provisions of the Contract, including General and Special Conditions and other Division 01 Specification Sections, apply to this Section.

#### 1.2 REFERENCED MATERIAL

- A. City and County of Denver, Department of Aviation, Standard Specification for Construction, General Contract Conditions
- B. The following documents may be available for examination at the Owner's offices unless otherwise noted. The referenced material and documents are not part of the Contract Documents unless otherwise specified.
  - 1. Environmental Impact Statement (EIS).
  - 2. Geotechnical Reports:
    - a. Borings, other field and laboratory explorations, and investigations have been made to indicate subsurface materials at particular locations. Explorations and investigations conducted by designers and their subconsultants are solely for the purpose of study and design.
    - b. The subsurface exploration and investigation information is presented or made available to indicate some of the conditions that may be encountered during construction and is offered as supplementary information only. Geotechnical information presented in the referenced material represents the opinion of soils consultants as to the character of the materials encountered. Subsurface information was directly obtained only at the specified location and necessarily indicates subsurface conditions only at the respective plan location, depths penetrated and only at the time of the exploration.
    - c. Neither the City nor the Designers assume any responsibility whatever in respect to the sufficiency or accuracy of borings made, or of the logs of test borings, or of other investigations, or of the interpretations made thereof, and there is no warranty or guarantee, either expressed or implied, that the conditions indicated by such investigations are representative of those existing throughout such area, or any part thereof, or that unforeseen developments may not occur. It is expressly understood that the making of deductions, interpretations, and conclusions from all of the accessible factual information, including the nature of the materials to be excavated, the difficulties of doing other work affected by the geology, groundwater elevations and other subsurface conditions at the site of the Work are the Contractor's sole responsibility.

- d. Information derived from inspection of logs of borings, topographic maps, technical memorandum, reports, or plans showing information of the subsurface of site conditions will not relieve the Contractor from any risk or from properly examining the site and making such additional investigations as the Contractor may elect or from properly fulfilling all the terms of the Contract Documents.
3. Available Conceptual Utility and Drainage Reports.
4. DEN Building Information Modeling (BIM) Design Standards Manual (DSM)
5. Woolpert, Inc. Report - "A Low Distortion Projection for Denver International Airport (DEN)", dated 12/10/2010.

**PART 2 - PRODUCTS (Not Used)**

**PART 3 - EXECUTION (Not Used)**

**PART 4 - MEASUREMENT**

4.1 METHOD OF MEASUREMENT

- A. No separate measurement shall be made for work under this Section.

**PART 5 - PAYMENT**

5.1 METHOD OF PAYMENT

- A. No separate payment will be made for work under this Section.

END OF SECTION **014210**

## SECTION 014220 - ABBREVIATIONS AND SYMBOLS

### PART 1 - GENERAL

#### 1.1 RELATED DOCUMENTS

- A. Drawings and general provisions of the Contract, including General and Special Conditions and other Division 01 Specification Sections, apply to this Section.

#### 1.2 REFERENCE LIST

- A. Documents published by the following agencies may be referenced within these Contract Documents to define the quality of materials, equipment, workmanship, and other features of Work. Unless otherwise stated, the reference documents shall be of the latest edition as of the date of the Advertisement for Bids.
- B. Wherever used in the Contract Documents, the following abbreviations will have the meanings listed:

| Abbreviation | Definition   |
|--------------|--|
| AALA         | American Association of Laboratory Accreditation                   |
| AAN          | American Association of Nurserymen                                 |
| AAO          | Affirmative Action Officer   |
| AASHTO       | American Association of State Highway and Transportation Officials |
| ACI          | American Concrete Institute  |
| ADA          | Americans with Disabilities Act                                    |
| AFI          | Air-Filter Institute   |
| AGTS         | Automated Ground Transportation System                             |
| AIA          | American Institute of Architects                                   |
| AISC         | American Institute of Steel Construction                           |
| AISI         | American Iron and Steel Institute                                  |
| AITC         | American Institute of Timber Construction                          |
| AMCA         | Air Moving and Conditioning Association                            |
| ANSI         | American National Standards Institute, Inc.                        |
| APA          | American Plywood Association                                       |
| APEN         | Air Pollution Emission Notes                                       |
| APWA         | American Public Works Association                                  |
| ARI          | Air Conditioning and Refrigeration Institute                       |
| ASCE         | American Society of Civil Engineers                                |

| <b>Abbreviation</b> | <b>Definition</b>  |
|---------------------|--|
| ASHRAE              | American Society of Heating, Refrigeration, and Air Conditioning Engineers |
| ASME                | American Society of Mechanical Engineers                                   |
| ASNT                | American Society for Non-Destructive Testing                               |
| ASPE                | American Society of Plumbing Engineers                                     |
| ASSE                | American Society of Sanitary Engineering                                   |
| ASTM                | American Society for Testing and Materials                                 |
| AWPA                | American Wood Preserver's Association                                      |
| AWS                 | American Welding Society   |
| AWWA                | American Water Works Association   |
| BID                 | Building Inspection Division, Department of Public Works                   |
| BIM                 | Building Information Modeling  |
| CAR                 | Corrective Action Report   |
| CCD                 | City and County of Denver  |
| CCR                 | Contractor Change Request  |
| CCRL                | Cement Concrete Reference Laboratory                                       |
| CD                  | Change Directive   |
| CDOH                | Colorado Department of Highways or Colorado Department of Health           |
| CDOT                | Colorado Department of Transportation                                      |
| CMEC                | Concrete Materials Engineering Council                                     |
| CN                  | Change Notice  |
| CO                  | Change Order   |
| COE                 | Corps of Engineers   |
| CPM                 | Critical Path Method   |
| CR                  | Change Request   |
| CRSI                | Concrete Reinforcing Steel Institute                                       |
| CSI                 | Construction Specifications Institute                                      |
| DEN                 | Denver International Airport   |
| DFD                 | Denver Fire Department   |
| DOT                 | United States Department of Transportation                                 |
| DOR                 | Designer of Record   |
| DWB                 | Denver Water Board   |
| EEO                 | Equal Employment Officer or Equal Employment Opportunity                   |
| EIA                 | Electronics Industry Association   |
| EIS                 | Environmental Impact Statement   |
| EPA                 | Environmental Protection Agency  |
| FAA                 | Federal Aviation Administration  |

| <b>Abbreviation</b> | <b>Definition</b>  |
|---------------------|--|
| FCC                 | Federal Communications Commission  |
| FHWA                | Federal Highway Administration   |
| FM                  | Factory Mutual Association   |
| FS                  | Federal Specifications (U.S. General Services Administration)                            |
| GCC                 | General Contract Conditions  |
| GIS                 | Geographic Information Systems   |
| GMP -               | Guaranteed Maximum Price   |
| IAPMO               | International Association of Plumbing and Mechanical Officials                           |
| IBC                 | International Building Code (published by ICC)   |
| IBR                 | Institute of Boiler and Radiator Manufacturer's  |
| ICBO                | International Conference of Building Officials   |
| ICC                 | International Code Council   |
| ICEA                | Insulated Cable Engineers Association  |
| IEEE                | Institute of Electrical and Electronic Engineers   |
| IES                 | Illuminating Engineering Society   |
| IMC                 | International Mechanical Code (published by ICBO)  |
| IPC                 | International Plumbing Code (published by ICBO)  |
| ISA                 | Instrument Society of America  |
| ITA                 | Independent Testing Agency   |
| MIL                 | Military Specifications (Naval Publications and Forms Center)                            |
| MSS                 | Manufacturers Standardization Society of the Valve and Fittings Industry                 |
| MUTCD               | Manual of Uniform Traffic Control Devices  |
| NAAB                | National Association of Air Balance  |
| NACE                | National Association of Corrosion Engineers  |
| NBS                 | National Bureau of Standards (now called National Institute of Standards and Technology) |
| NEC                 | National Electric Code (NFPA 70)   |
| NECA                | National Electric Contractors Association  |
| NEMA                | National Electrical Manufacturer's Association   |
| NESC                | National Electrical Safety Code  |
| NFC                 | National Fire Code (as published by NFPA)  |
| NFPA                | National Fire Protection Association   |
| NICET               | National Institute for the Certification of Engineering Technologies                     |
| NIST                | National Institute of Standards and Technology   |
| NGS                 | National Geological Survey   |
| NLMA                | National Lumber Manufacturers Association  |
| NOAA                | National Oceanic and Atmospheric Administration  |



| <b>Abbreviation</b> | <b>Definition</b>  |
|---------------------|--|
| NRMCA               | National Ready Mix Concrete Association                            |
| NTP                 | Notice to Proceed  |
| NVLAP               | National Voluntary Laboratory Accreditation Program                |
| OSHA                | Occupational Safety and Health Administration                      |
| PCA                 | Portland Cement Association  |
| PCI                 | Prestressed Concrete Institute                                     |
| PDM                 | Precedent Diagram Method   |
| PS                  | Product Standard of NIST (U.S. Department of Commerce)             |
| PM                  | Project Manager  |
| PMT                 | Project Management Team  |
| PXP                 | Project Execution Plan   |
| QA                  | Quality Assurance  |
| QC                  | Quality Control  |
| RFI                 | Request for Information  |
| RTD                 | Regional Transportation District                                   |
| SC                  | Special Contract Condition   |
| SDI                 | Steel Door Institute   |
| SMACNA              | Sheet Metal and Air Conditioning Contractor's National Association |
| SSPWC               | Standard Specifications for Public Works Construction              |
| TCP                 | Traffic Control Plan   |
| TSA                 | Transportation Security Administration                             |
| UL                  | Underwriters Laboratories, Inc.                                    |
| USC                 | United States Code   |
| WBS                 | Work Breakdown Schedule  |

## **PART 2 - PRODUCTS (Not Used)**

## **PART 3 - EXECUTION (Not Used)**

## **PART 4 - MEASUREMENT**

### **4.1 METHOD OF MEASUREMENT**

- A. No separate measurement shall be made for work under this Section.

## **PART 5 - PAYMENT**

### 5.1 METHOD OF PAYMENT

- A. No separate payment will be made for work under this Section.

END OF SECTION **014220**



## SECTION 014225 - REFERENCE STANDARDS

### PART 1 - GENERAL

#### 1.1 RELATED DOCUMENTS

- A. Drawings and general provisions of the Contract, including General and Special Conditions and other Division 01 Specification Sections, apply to this Section.

#### 1.2 SUMMARY

- A. This Section contains a summary of industry-accepted and recognized standards published by trade associations, government, and institutional organizations that are referred to in the various Sections of these specifications or elsewhere in the Contract Documents.
- B. Standards listed herein are included in the Contract Documents by this reference and become a part of the Contract Documents to the same extent as though included in their entirety unless specific limitations are noted in the individual specifications Sections.
- C. Listings of reference standards include name and address of the organization publishing the standard, and the full name and designator of each of the standards referenced herein.
- D. If a publication date or edition number is listed with the reference standard, that publication date or edition number shall apply. Otherwise, the publication date or edition number in effect at the Contract date shall apply.
- E. Inclusion of reference standards herein does not make the DEN Project Manager an agent of the publishing agency, nor does it obligate the DEN Project Manager to perform inspections required by or to enforce rules or regulations contained in the reference standards.

#### 1.3 SCHEDULE OF REFERENCE STANDARDS

- A. American Association of State Highway and Transportation Officials (AASHTO), 444 North Capitol Street, NW, Suite 249, Washington, DC 20090:
  - 1. AASHTO M 36–Corrugated Steel Pipe, Metallic-Coated for Sewers and Drains.
  - 2. AASHTO M216–Standard Specification for Lime for Soil Stabilization.
  - 3. AASHTO T26–Standard Method of Test for Water to be Used in Concrete.
  - 4. AASHTO T84–Specific Gravity and Absorption of Fine Aggregate.
  - 5. AASHTO T85–Specific Gravity and Absorption of Coarse Aggregate.
  - 6. AASHTO T103–Soundness of Aggregates by Freezing and Thawing
  - 7. AASHTO T219–Standard Methods of Testing Lime for Chemical Constituents

and Particle Sizes.

- B. American Concrete Institute (ACI) 38800 Country Club Drive, Farmington Hills, MI 48331
1. ACI 211.1—Standard Practice for Selecting Proportions for Normal, Heavyweight, and Mass Concrete.
  2. ACI 301—Specifications for Structural Concrete for Buildings.
  3. ACI 304—Recommended Practices for Measuring, Mixing, Transporting and Placing Concrete.
  4. ACI 304.2R—Placing Concrete by Pumping Methods.
  5. ACI 305R—Hot Weather Concreting.
  6. ACI 306R—Cold Weather Concreting.
  7. ACI 318—Building Codes Requirements for Structural Concrete
    - a. Reference to ACI 318 may be limited to more stringent requirements of local building code.
- C. American Society for Testing and Materials (ASTM), International 100 Barr Harbor Drive, PO Box C700, West Conshohocken, PA 19428:
1. ASTM A 27—Mild to Medium Strength Carbon - Steel Casting for General Application.
  2. ASTM A 36—Structural Steel.
  3. ASTM A 47—Malleable Iron Castings.
  4. ASTM A 82—Specification for Steel Wire, Plain, for Concrete Reinforcement: Replaced by A1064
  5. ASTM A 123—Hot-dip Galvanizing.
  6. ASTM A 184—Specification for Fabricated Deformed Steel Bar Mats for Concrete Reinforcement.
  7. ASTM A 185—Specifications for Steel Welded Wire, Fabric, Plain, for Concrete Reinforcement: Replaced by A1064
  8. ASTM A 283—Low and Intermediate Tensile Strength Carbon Steel Plates, Shapes and Bars.
  9. ASTM A 615—Specification for Deformed and Plain Billet-Steel Bars for Concrete Reinforcement.
  10. ASTM A 706—Specification for Low-Alloy Steel Deformed Bars for Concrete Reinforcement.
  11. ASTM C 25—Method for Chemical Analysis of Limestone, Quicklime, and Hydrated Lime.
  12. ASTM C 29—Unit Weight and Voids in Aggregate
  13. ASTM C 31—Methods of Making and Curing Concrete Test Specimens in the Field.
  14. ASTM C 33—Specification for Concrete Aggregates.
  15. ASTM C 39—Test Method for Compressive Strength of Cylindrical Concrete Specimens.
  16. ASTM C 42—Method of Obtaining and Testing Drilled Cores and Sawed Beams of Concrete.
  17. ASTM C 76—Reinforced Concrete Culvert, Storm Drain, and Sewer Pipe.
  18. ASTM C 88—Soundness of Aggregates by Use of Sodium Sulfate or Magnesium

Sulfate.

19. ASTM C 94—Specification for Ready Mixed Concrete.
20. ASTM C 109—Compressive Strength of Hydraulic Cement Mortars
21. ASTM C 110—Methods for Physical Testing of Quicklime, Hydrated Lime, and Limestone.
22. ASTM C 117—Materials Finer than 75 mm (No. 200) Sieve in Mineral Aggregates by Washing.
23. ASTM C 131—Resistance of Abrasions of Small Size Coarse Aggregate by Use of the Los Angeles Machine.
24. ASTM C 136—Method for Sieve Analysis of Fine and Coarse Aggregates.
25. ASTM C 138—Unit Weight, Yield, and Air Content of Concrete.
26. ASTM C 143—Test Method for Slump of Hydraulic – Cement Concrete
27. ASTM C 150—Specification for Portland Cement
28. ASTM C 171—Specification for Sheet Material for Curing Concrete.
29. ASTM C 172—Method of Sampling Fresh Concrete.
30. ASTM C 173—Test Method for Air Content of Freshly Mixed Concrete by the Volumetric Method.
31. ASTM C 231—Test Method for Air Content of Freshly Mixed Concrete by the Pressure Method.
32. ASTM C 260—Specification for Air Entraining Admixture for Concrete.
33. ASTM C 309—Specification for Liquid Membrane-Forming Compounds for Curing Concrete.
34. ASTM C 443—Joints for Concrete Pipe and Manholes, using Rubber Gasket
35. ASTM C 494—Specification for Chemical Admixtures for Concrete.
36. ASTM C 595—Blend Hydraulic Cements.
37. ASTM C 618—Specification for Coal Fly Ash and Raw or Calcined Natural Pozzolan for use in Concrete
38. ASTM C 655—Reinforced Concrete D Load Culvert, Storm Drain, and Sewer Pipe.
39. ASTM C 789—Precast Reinforced Concrete Box Sections for Culverts, Storm Drains and Sewers: Replaced by C1433
40. ASTM C 803—Test Method for Penetration Resistance of Hardened Concrete.
41. ASTM C 805—Test Method for Rebound Number of Hardened Concrete.
42. ASTM C 977—Specification for Quicklime and Hydrated Lime for Soil Stabilization.
43. ASTM D 75—Sampling Aggregate.
44. ASTM D 422—Test Method for Particle Size Analysis of Soils.
45. ASTM D 516-88—Standard Test Method for Sulfate Ions in Water.
46. ASTM D 693—Crushed Stone, Crushed Slag and Crushed Gravel for Dryer Water-Bound Macadam Base Courses and Bituminous Macadam Base and Surface Courses of Pavements: Withdrawn
47. ASTM D 698—Laboratory Compaction Characteristics of Soil using Standard Effort
48. ASTM D 751—Test Method for Coated Fabrics
49. ASTM D 1556—Test Method for Density of Soil in Place by the Sand-Cone Method.
50. ASTM D 1557—Laboratory Compaction Characteristics of Soil using Modified Effort
51. ASTM D 1682—Ultraviolet Resistance Grab Tensile Strength Grab Tensile Elongation Toughness: Replaced by D5034 and D5035

52. ASTM D 1751—Specification for Preformed Expansion Joint Fillers for Concrete Paving and Structural Construction.
  53. ASTM D 1752—Specification for Preformed Sponge Rubber and Cork Expansion Joint Fillers for Concrete Paving and Structural Construction.
  54. ASTM D 2167—Test Method for Density of Soil in Place by the Rubber-Balloon Method.
  55. ASTM D 2216—Method for Laboratory Determination of Water (Moisture) Content of Soil, Rock and Soil Aggregate Mixtures.
  56. ASTM D -79 (2011) Hydroxypropyl Methylcellulose
  57. ASTM D 2419—Sand Equivalent Value of Soils and Fine Aggregate.
  58. ASTM D 2487—Test Method for Classification of Soils for Engineering Purposes.
  59. ASTM D 2922—Test Method for Density of Soil and Soil-Aggregate in Place by Nuclear Method: Replaced by D6938
  60. ASTM D 3017—Test Method for Moisture Content of Soil and Soil-Aggregate in Place by Nuclear Methods (Shallow Depth): Replaced by D6938
  61. ASTM D 3665—Random Sampling of Paving Materials.
  62. ASTM D 4253—Test Method for Maximum Index Density of Soils Using Vibratory Table.
  63. ASTM D 4318—Test Method for Liquid Limit, Plastic Limit, and Plasticity Index of Soils.
  64. ASTM D 4397—Specification for Polyethylene Sheeting for Construction, Industrial and Agricultural Applications.
  65. ASTM D 4546—Test Method for One-Dimensional Swell or Settlement Potential of Cohesive Soils.
  66. ASTM E 329—Specification for Agencies Engaged in Construction Inspection, Testing, or Special Inspection
  67. ASTM F 477—Elastomeric Seals (Gaskets) for Joining Plastic Pipe.
  68. ASTM F 758—Smooth-Wall Poly (Vinyl Chloride) (PVC) Plastic Underdrain Systems for Highway, Airport and Similar Drainage.
- D. American Welding Society (AWS), 550 NW LeJeune Road, Miami, FL 33135 AWS Code for Welding in Building Construction (Structural Welding Code).
- E. Concrete Reinforcing Steel Institute (CRSI) 933 N. Plum Grove Road, Schaumburg, IL 60195, (312) 490-1700:
1. Manual of Standard Practice.
- F. Colorado Department of Transportation (CDOT) Division of Administration, Office of Bid Plans, 4201 E. Arkansas Avenue, Denver, CO 80222:
1. Standard Specifications for Road and Bridge Construction (latest edition) Colorado Standard Plans, M&S Standards.
- G. Federal Highway Administration (FHWA) Superintendent of Documents, US Government Printing Office, Washington DC, 20402:
1. Manual of Uniform Traffic Control Devices (latest edition).

**PART 2 - PRODUCTS (Not used)**

**PART 3 - EXECUTION (Not used)**

**PART 4 - MEASUREMENT**

4.1 METHOD OF MEASUREMENT

- A. No separate measurement shall be made for work under this Section.

**PART 5 - PAYMENT**

5.1 METHOD OF PAYMENT

- A. No separate payment will be made for work under this Section.

END OF SECTION **014225**





## SECTION 014230 - DEFINITIONS AND CONVENTIONS

### PART 1 - GENERAL

#### 1.1 RELATED DOCUMENTS

- A. Drawings and general provisions of the Contract, including General and Special Conditions and other Division 01 Specification Sections, apply to this Section.

#### 1.2 SUMMARY

- A. This Section contains a list of definitions of words or phrases and grammatical or contextual conventions commonly used in these Contract Documents.

#### 1.3 DEFINITIONS

- A. General: Basic Contract definitions are included in the Conditions of the Contract.
- B. Alphabetical Listing of Definitions:
  - 1. **As indicated:** Shown on the drawings by graphic indication, notes, or schedules, or written in the specifications or elsewhere in the Contract Documents.
  - 2. **As directed, as approved, as requested:** Unless otherwise indicated, these terms imply "by the DEN Project Manager" and require that an instruction be obtained by the Contractor from the DEN Project Manager.
  - 3. **Concealed:** Embedded in masonry, concrete, or other construction; installed in furred spaces; within double partitions or hung ceilings; in trenches; in crawl spaces or in enclosures.
  - 4. **Ensure:** To make certain in a way that eliminates the possibility of error.
  - 5. **Exposed:** Not installed underground or "concealed" as defined above.
  - 6. **Furnish or Provide:** To supply, install and connect complete and ready for safe and regular operation of particular work unless specifically otherwise noted.
  - 7. **Indicated, Shown, or Noted:** As depicted on drawings or specifications.
  - 8. **Install:** To erect, mount and connect complete with related accessories.
  - 9. **Or equal, or approved equal:** Refers to products which, in the opinion of the DEN Project Manager, are similar in all respects to products specified by proprietary brand name. Refer to Section 012510 "Substitutions" for procedures for submittal of proposed substitutions.
  - 10. **Rework:** To repair existing items or work required to be removed and replaced in order to accomplish the Work in accordance with the Contract Documents.
  - 11. **Related Work:** Includes, but not necessarily limited to, mentioned work associated with, or affected by, the Work specified.
  - 12. **Reviewed, Satisfactory, Accepted, or Directed:** Assumes by or to the DEN Project Manager.
  - 13. **Similar, or Equal:** Same in materials, weight, size, design, construction, capacity, performance, and efficiency of specified product.

14. **Supply:** To purchase, procure, acquire and deliver complete with related accessories.
15. **Unless Otherwise Indicated and Unless Otherwise Noted:** General note to perform work as indicated or shown on drawings or in specifications unless specifically directed otherwise elsewhere in the Contract Documents; may be abbreviated "U.O.N.", "U.O.I.", or "U.N.O.".

C. BIM Model Definitions:

1. **Building Information Model (BIM):** BIM is a digital representation of the physical and functional characteristics of the Project and is referred as a Model(s), which term may be used to describe a Model Element, a single Model or technology used to create the Model.
2. **Design Model:** A Model that has reached the stage of completion that would customarily be expressed by an architect or engineer in two-dimensional Construction Documents.
3. **Construction Model:** The equivalent of shop drawing and other information useful to construction. A model that consists of data imported from a "Design Model or", if none exist, from a designer's "Construction Document".
4. **Federated Model:** Distinct component models "linked" together in such a manner that the linked data sources so not lose the indent or integrity by being so linked.
5. **Level of Development (LOD):** LoD describes the level of completeness to which a Model Element is developed.
6. **Model Element:** Is a portion of the BIM representing a component system or assembly within a building or building site.
7. **Model Element Author:** The party responsible for developing the content of a specific Model Element to the LoD for a particular phase of the Project.

1.4 BIM REFERENCE STANDARDS

- A. Refer to the DEN BIM Design Standard Manual (DSM) for the proposed minimum requirements of the BIM Execution Plan. The execution plan shall be further developed jointly with DEN and the Contractor to specifically address the administrative steps necessary to provide comprehensive BIM system before during and after construction.

1.5 CONVENTIONS

A. Specifications Format:

1. In order to standardize the location of information in the Contract Documents, the specifications generally are organized in one or more of the following formats:
  - a. The "MASTERFORMAT" 2011 Edition published by the Construction Specifications Institute.
  - b. The Standard Specifications for Road and Bridge Construction published by CDOT.
  - c. The alphanumeric system as published by the FAA.

B. Organization of Drawings and Specifications:

1. Organization of the specifications into divisions and sections, and arrangement or numbering of drawings is intended solely for the convenience of the Contractor in the Contractor's responsibilities to divide the Work among subcontractors or to establish the extent of work to be performed by any trade.
2. Neither the City nor the DEN Project Manager assume any liability arising out of jurisdictional issues or claims advanced by trade organizations or other interested parties based on the arrangement or organization of drawings or specifications.

C. Gender and Number:

1. For convenience and uniformity, parties to the Contract, including the City, Contractor, and DEN Project Manager, and their subcontractors, suppliers, installers, consultants or other interested parties are referred to throughout the Contract Documents as if masculine in gender and singular in number. Such reference is not intended to limit the meaning of the Contract Documents to the masculine gender or singular number.

D. Singular vs. Plural:

1. Materials, products, equipment, or other items of work referred to in the singular shall be construed as plural where applicable by the intent of the Contract Documents and shall not limit quantities to be provided by the Contractor.

E. Imperative Mood:

1. Specifications and notes on the drawings or elsewhere in the Contract Documents are generally written in the imperative mood as instructions to the Contractor, whether the Contractor is specifically addressed or not.

F. References to Subcontractors or Trades

1. References to subcontractors, trades or other entities, which are not parties to the Contract, shall be construed as meaning the Contractor whose responsibility it shall be to divide the Work among subcontractors or trades. Such references are used as a matter of convention, and are not intended to preclude or direct the Contractor's responsibility to divide the Work.

G. Abbreviations

1. A list of abbreviations used in the Contract Documents is included in Technical Specifications Section 014220 "Abbreviations and Symbols"; an abridged list of abbreviations used on the drawings is included with the drawings.
2. Abbreviations are believed to be those in general use in the construction industry. Contact the DEN Project Manager for clarification of abbreviations for which the meaning is not clear.

**PART 2 - PRODUCTS (Not Used)**

**PART 3 - EXECUTION (Not Used)**

**PART 4 - MEASUREMENT**

4.1 METHOD OF MEASUREMENT

- A. No separate measurement shall be made for work under this Section.

**PART 5 - PAYMENT**

5.1 METHOD OF PAYMENT

- A. No separate payment will be made for work under this Section.

END OF SECTION **014230**

## **SECTION 014510 - CONTRACTOR QUALITY CONTROL**

### **PART 1 - GENERAL**

#### **1.1 RELATED DOCUMENTS**

- A. Drawings and general provisions of the Contract, including General and Special Conditions and other Division 01 Specification Sections, apply to this Section.

#### **1.2 SUMMARY**

- A. This Section identifies the Quality Control activities to be performed during all phases of the Contract by the Contractor.
- B. The Contractor shall have in place a Quality Control Program as necessary to ensure that all materials and work are completed in compliance with Contract Documents. The Contractor is solely responsible for Quality Control and shall provide the necessary quality control personnel to assure that all materials, workmanship, and tests are in conformance with the Project documents with the exception of those tests and/or audits that may be conducted by the City as defined in the contract documents.
- C. Test schedules and/or testing requirements for materials used on this project are included in the technical specifications. Laboratory and field-testing identified in the specifications shall be conducted by a Testing Agency retained by the Contractor; hereafter is referred to as the Contractor Testing Agency (CTA).
- D. The City or its consultant working as the City agent will employ a testing agency to perform all the required Quality Assurance and Special Inspection Testing of material and Inspection of workmanship required by the Contract Documents and the Building Official to fulfill the code and the regulatory authority's requirements. The Contractor must schedule these tests and provide access to the City agents' inspectors and testers to perform these tests and inspections. The performance of the tests by the City does not relieve the Contractor of the responsibility to deliver a fully functional building meeting all the requirements of the Contract Documents and their intent. The Contractor must develop its own testing program for processing, acceptance from the subcontractor or suppliers at a frequency defined by the contractor for its own process control and to assure delivery of the intended acceptable workmanship. All time impacts of testing and retesting shall be accounted for in the updated schedule and any mitigation of time impacts shall be the responsibility of the Contractor.

#### **1.3 SUBMITTALS**

- A. Refer to Section 013300 "Submittals" and Section 013325 "Submittal Procedures" for submittal requirements.
- B. Quality Control Plan: Within ten (10) days after Notice to Proceed, the Contractor shall

submit a Quality Control Plan for review and acceptance. The Quality Control Plan shall be accepted by the DEN Project Manager prior to any Work or materials being incorporated into the Project. Acceptance by the DEN Project Manager does not relieve the Contractor of its responsibility to comply with the Contract Requirements. The Contractor Quality Control Plan shall address the following as a minimum:

1. A general description of Quality Control monitoring to be performed until final acceptance by DEN. Include monitoring activities of Work and the work site during times that no construction activity is scheduled to take place.
  - a. No work requiring QC inspection and testing shall take place without QC inspection and testing staff on site.
2. An individual designated by the Contractor and approved in writing by the DEN Project Manager whose [sole] responsibility is Quality Control Management. This individual shall be highly qualified in all phases of construction as it relates to this Project and shall have the authority to direct work changes required to bring the Work into conformance with Contract requirements, including stopping non-conforming work in progress. A detailed resume of the proposed Quality Control Manager including applicable education, experience, and certifications shall be included in the Quality Control Plan.
  - a. At the discretion of the DEN Project Manager, for Small Projects, Early Work Packages and Task Orders all of value less than \$1,000,000 or a duration which is less than three (3) months, the Contractor may assign one of the Contractor's staff, i.e. Contractor's Superintendent, Office Engineer, Field Engineer, or Contractor's Project Manager as Quality Control Manager. The assigned person must be on site while work requiring QC inspection and testing is being completed and available to discuss quality issues, manage all aspects of the Project Quality Control Plan, coordinate all required Special Inspection and Quality Assurance testing, and provide proposed solutions on all quality issues at any time as to not cause any delay to the project. Any delays caused in part or in all due to defective or no conforming work shall be borne by the Contractor.
3. Quality Control inspection staff as needed to assist the Quality Control Manager with implementation of the Quality Control Program. Duties of the Quality Control Inspectors shall be limited strictly to inspection of the ongoing work. Sampling and testing of materials shall be performed by Quality Control personnel other than Quality Control Inspectors. Quality Control Inspectors shall inspect only those work elements for which they are qualified. Resumes of the proposed Quality Control Inspectors including applicable education, experience and certifications shall be included in the Quality Control Plan.
4. An Organization Chart identifying all Quality Control staff by name and function. The chart shall indicate the total staff required to implement all elements of the Quality Control Program, including inspection and testing for each item of work including tests performed by the CTA or DTA. If necessary, different Quality Control staff can be utilized for specific inspection and testing functions for different items of work. The chart shall show that the Quality Control Manager, Quality Control Inspectors, and Quality Control testing personnel are outside of

- the production staff with clear lines of authority for Quality Control.
5. The City and/or the City Program Management Team acting as the City agent will employ a DTA. The Contractor's testing and inspection shall be performed for the processing, preparation and to request City's inspection and as necessary to produce the required product as specified in the Contract Documents. The Contractor shall meet the minimum inspection and testing frequencies specified in the contract documents. When the contract documents do not specify minimum inspection and testing frequencies the Contractor shall propose in writing to the DEN Project Manager a QC inspection and testing frequencies that meet or exceed industry standards for the material and work being placed or conducted.
  6. Any test performed by any agency on the Project shall be recorded and show a passing re-test of all failing tests.
    - a. All test results shall be made available for inspection by the DEN Project Manager. This includes tests that are above the QC testing frequency required.
  7. Any tests submitted by the Contractor for basis of acceptance, or payment reduction when performed by the Contractor's agency, must meet all standards and must be certified to have followed approved procedure, processed in a certified lab by properly certified or licensed personnel by properly certified testers and on calibrated and certified equipment. Authentications of tests must be preapproved and cannot be selectively submitted. All tests shall be recorded in the field witnessed by DEN inspector to be accepted as a record test of the material in question. Any failing tests could be the sole basis for rejecting the material.
  8. Each technical specification division's requirements for quality control identifying each item requiring submittal and approval/acceptance prior to installation of work, all inspections to be performed during work and prior to acceptance of work, each item of work requiring testing by the independent testing agency or the City provided testing agency, and the testing frequency.
  9. The plan shall address all elements of special inspection required by the statement of special inspection as approved by the Building Official. All special inspections and tests will be performed by agencies employed by the City.
  10. The Contractor is responsible for the complete record of inspection file including but not limited to all manufacturer certificates, certificates of material compliance, Certificates of Material Testing Record, successful re-inspection of all deficiency items, proper deposition of design related Non-Conformance reports (NCR), Structural Engineers' observation reports, certification letters from the DTA, Building Inspectors' records of approvals, permit cards, fire suppression and fire-alarm tests records as witnessed by the authorities of jurisdiction and any record necessary to achieve a certificate of occupancy.
  11. The Contractor must keep track of all logs of discrepancies and submit periodic updates, as required by the DEN Project Manager, of all open issues and track the closure of open items in a timely manner.
  12. Establish controls and documentation format to ensure that items or materials that have been accepted through receiving inspection are used or installed. Identification and traceability shall be provided throughout all inspections, test activities, and records. For stored items, provisions shall be made for the control



- of item/material identification, consistent with the expected duration and type of storage.
13. A methodology of monitoring, testing, and exercising of all equipment, valves, and/or assemblies to ensure the Work installed is in proper working order.
  14. A list of suppliers and subcontractors. This list shall include items to be supplied by each supplier and/or subcontractor and shall identify work to be performed by each subcontractor. The list shall be updated and resubmitted as required.
  15. All approvals related to Special Inspection are subject to the acceptance or approval of the Building Official.
  16. Emergency contact information including name, company, title, work phone number, home phone number, and other means of contact. The Emergency Contact list shall include at least four individuals. The Emergency Contact list shall be maintained on a daily basis. In the event there is any change in any of the information, the Contractor shall forward the updated list to the DEN Project Manager and to DEN Maintenance Control (303-342-2800). The Emergency Contact list shall include the project number, project title, and date of issue.
- C. The Contractor shall transmit the following daily reports to the DEN Project Manager electronically PRIOR TO THE CLOSE OF BUSINESS ON the following work day:
1. CM-13 Contractors Daily Construction Report. The Foreman may add sheets of information to this form as needed.
  2. CM-07 Daily Quality Control Inspection Report and all CTA test results performed that day.
  3. CM-08 Daily DEN Time and Materials Report
- D. Deficiency List: The Quality Control Manager shall establish a deficiency list including the minimum information for each deficiency item; description, date, location, drawings reference, detail reference, specification reference, and superseding document NCR, date of expected solution date repaired date inspected by City representative and accepted.
- 1.4 DOCUMENTATION
- A. The Contractor shall not change or alter approved submittals, procedures, specifications, drawings/MODELS, or other pertinent documentation without the DEN Project Manager's written authorization.
  - B. All records and documents that are quality related shall be prepared, identified and maintained by the Contractor and shall be made available to DEN upon request. Records shall be protected from damage, deterioration, or loss. A copy of the records and documents shall be maintained at the Work site at all times unless the DEN Project Manager has approved other locations in writing. Retention time for all quality records shall be not less than three (3) years from date of Final Acceptance of the Contract.
  - C. The Contractor is responsible for the complete record of inspection file including but not limited to all manufacturer certificates, certificates of material compliance, Certificates of Material Testing Record, successful re-inspection of all deficiency items,

proper deposition of design related NCRs, Structural Engineers' observation reports, certification letters from the DTAs, Building Inspectors' records of approvals, permit cards, fire suppression and fire-alarm tests records as witnessed by the authorities of jurisdiction and any record necessary to achieve a Certificate of Occupancy.

- D. The Contractor shall maintain records at the actual worksite and at Contractor's office to show the inspection status of materials and items installed in order to ensure that the required inspections and tests have been performed in a timely and correct manner.
- E. The Contractor must keep a record of all deficiency issues and show positive evidence of closure (passing re-inspection or re-test) to every issue.

## 1.5 INSPECTIONS AND TESTS

- A. Inspections, tests and system shut down requests, conducted by persons or agencies other than the Contractor, shall not in any way relieve the Contractor of the responsibility and obligation to meet all specifications and the referenced standards. The Contractor's designated Quality Control Representative shall inspect the work and shall ensure the Work complies with the Contract requirements prior to any requests for inspection or testing.
- B. When the specifications, laws, ordinances, rules, regulations or orders of any public agency having jurisdiction require the DEN Project Manager's surveillance of inspections or tests, the Contractor shall notify the DEN Project Manager, in writing, of the place, date and time 48 hours prior to the inspection and/or test. The Contractor shall be responsible for notifying and requesting inspection by other agencies including but not limited to the Denver Building Inspection Division, Denver Fire Department, and Denver Water Department. Prior to request for other agency inspections, the Contractor shall meet and plan inspection times with the DEN Project Manager.
- C. Special inspections or tests may be required by the technical specifications, City, State and/or Federal Agencies in addition to those tests already performed. The Contractor shall notify the DEN Project Manager, in writing, at least 48 hours in advance of the additional inspections or tests.
- D. Quantities will be verified as defined in the Pre-Work Meetings.

## 1.6 INSPECTION PLAN

- A. The Contractor shall utilize the following six-point inspection plan to ensure the conformance of the Work performed by the Contractor meets the requirements of the Contract Drawings and specifications, the referenced codes and standards and the approved submittals:
  - 1. Pework Coordination: Prior to the start of construction work on the Contract and prior to the start of Work under each separate specification section and prior to the start of Work where a change in a construction operation is contemplated by

the Contractor, and prior to a new subcontractor starting work, a coordination meeting to ensure that the Contractor's personnel have no misunderstandings regarding their safety and quality procedures as well as the technical requirements of the Contract will be held with the Contractor's superintendent, Quality Control and Safety representatives, and DEN Project Manager. Supervisory, Safety and Quality Control, representatives of all applicable subcontractors will also attend. Prior to the meeting, the Contractor's Quality Control Manager shall provide the DEN Project Manager with a meeting agenda for review. The Contractor's Quality Control Manager shall conduct the meeting and distribute the approved agenda. The Quality Control Manager shall develop and electronically distribute finalized meeting minutes within one business day upon completion of the meeting. The following items shall be presented and reviewed by the Contractor:

- a. Contract requirements and specifications.
  - b. Shop drawings, certifications, submittals, models, and as-built drawings.
  - c. Testing and inspection program and procedures.
  - d. Contractor's Quality Control program.
  - e. Familiarity and proficiency of the Contractor's and subcontractor's workforce to perform the operation to required workmanship standards including certifications of installers.
  - f. Safety, security, and environmental precautions to be observed.
  - g. Any other preparatory steps dependent upon the particular operation.
  - h. The Contractor's means and methods for performing the Work.
2. Initial Inspection: Upon completion of a representative sample of a given feature of the Work and no later than two weeks after the start of a new or changed operation, the DEN Project Manager and/or the DEN Project Manager's designated representatives will meet with the Contractor's Quality Control representative and applicable subcontractor's supervisor and their Quality Control representatives to check the following items, as a minimum:
- a. Workmanship to established quality standards.
  - b. Conformance to Contract Drawings, specifications and the accepted shop drawings.
  - c. Adequacy of materials and articles utilized.
  - d. Results of inspection and testing methods.
  - e. Adequacy of as-built drawings/MODELS maintained daily.
  - f. Once accepted, the representative sample will become the physical baseline by which ongoing work is compared for quality and acceptability. To the maximum practical extent, approved representative samples of work elements shall remain visible until all work in the appropriate category is complete. Acceptance of a sample does not waive or alter any Contract requirements or show acceptance of any deviation from the Contract not approved in writing by the DEN Project Manager.
3. Follow-up Inspection: The Contractor's Quality Control representative will monitor the Work to review the continuing conformance of the Work to the workmanship standards established during the preparatory and initial inspections.
4. Completion Inspection: Forty-eight (48) hours prior to the completion of an item

or segment of work and prior to covering up any work, the Contractor shall notify the DEN Project Manager, in writing, who will verify that the segment of work is substantially complete, all inspections and tests have been completed and the results are acceptable. The purpose of this inspection is to allow further corrective work upon, or integral to, the completed segment of work. THIS IS NOT AN ACCEPTANCE INSPECTION. If any items are determined to be deficient, need correction or are non-conforming, a Deficiency List will be prepared and issued to the respective Contractor for correction, repair, or replacement of any deficient or non-conforming items. The DEN Project Manager and Contractor's Quality Control representative will verify the correction of the deficient and/or non-conforming items prior to the start of the next operation.

5. Pre-Final Acceptance Inspection: Prior to requesting a Pre-Final Acceptance Inspection by DEN, all work and operational systems to be inspected shall be satisfactorily completed and tested by the Contractor. The Contractor's written request for this inspection shall be made seventy-two (72) hours in advance. With the request shall come a list of any known deficiencies and when they will be corrected. If the list is too large or contains too many significant items, in the opinion of the DEN Project Manager, no inspection will be held because of the incompleteness of the Work.
6. The DEN Project Manager will schedule the Pre-Final Acceptance Inspection and will prepare a list of deficient items (punch list) discovered during the inspection. If during the inspection, the list becomes too large or too many significant items are on the list, the inspection will be canceled by the DEN Project Manager. After the inspection is completed, the Deficiency List will be transmitted to the Contractor for correction of the deficient items.
7. Final Acceptance Inspection: After the Contractor has completed all items on the Deficiency List (generated from the Pre-Final Acceptance Inspection), he shall request a Final Acceptance Inspection. The request shall be made in writing at least seventy-two (72) hours in advance of the inspection. All areas must be cleaned and ready for turnover prior to this inspection. The DEN Project Manager, the design consultant, a representative of the funding agency (if applicable) and other interested parties will inspect the subject Work to ensure that all deficiencies have been satisfactorily attended to and that no new deficiencies have appeared and that all systems are completely functional. Any outstanding or additional deficient items will be noted and handled per the requirements of the Pre-Final Acceptance Inspection noted above until the Work is acceptable to the DEN Project Manager.

## 1.7 CONTRACTOR SUBMITTAL OF PROPOSED CONTRACTOR'S TESTING AGENCIES

- A. Refer to Section 014525 - Material Testing Agency

---

## **PART 2 - PRODUCTS (Not Used)**

## **PART 3 - EXECUTION**

### **3.1 REQUIREMENTS**

- A. All materials required for the Contract shall be new except where specified otherwise. The DEN Project Manager may elect to perform additional inspections and/or tests at the place of the manufacture, the shipping point or at the destination to verify conformance to applicable specifications. Inspections and tests performed by DEN shall not relieve the Contractor from the responsibility to meet the specifications, nor shall such inspections/tests be considered a guarantee for acceptance of materials that will be delivered at a later time.
- B. Materials accepted based on a Certificate of Compliance may be sampled and inspected/tested by DEN or its designer at any time. The fact that the materials were accepted based on such certification shall not relieve the Contractor of the responsibility to use materials that conform to the specifications.
- C. The Contractor shall impose upon suppliers the same quality control requirements, including inspection and test procedures, as imposed upon him by the specifications and referenced standards. The Contractor shall apply appropriate controls, designed to ensure that all materials supplied meet the requirements and specifications.

## **PART 4 - MEASUREMENT**

### **4.1 METHOD OF MEASUREMENT**

- A. No separate measurement shall be made for work under this Section.

## **PART 5 - PAYMENT**

### **5.1 METHOD OF PAYMENT**

- A. No separate payment will be made for work under this Section.
- B. Refer to Article 1706 - Removal of Defective Materials and Work in the General Contract Conditions, 2011 Edition.

**END OF SECTION 014510**

## SECTION 014525 - MATERIAL TESTING AGENCY

### PART 1 - GENERAL

#### 1.1 RELATED DOCUMENTS

- A. Drawings and general provisions of the Contract, including General and Special Conditions and other Division 01 Specification Sections, apply to this Section.

#### 1.2 SUMMARY

- A. The Contractor shall employ the services of a Material Testing Agency; hereafter referred to as the Contractor Testing Agency (CTA). This Section identifies the requirements for the Contractor to employ a Material Testing Agency and identifies the required activities of the Material Testing Agency.
- B. Laboratory and field-testing requirements to be conducted by the CTA for materials and construction methods used on this project are included in the appropriate technical specifications. Where the Specifications reference the CDOT Standard Specifications for Road and Bridge Construction, the references shall also mean CDOT Field Materials Manual for schedule of tests unless otherwise stated. As a minimum, the CTA described in this Section shall perform all applicable tests listed in the manual including the independent assurance sampling and testing. In the event of such a conflict between the schedule and a specification in these technical provisions, the more comprehensive testing shall govern unless otherwise noted.
- C. Inspections and tests conducted by the CTA shall not in any way relieve the Contractor of the Contractor's responsibility and obligation to meet all specifications and referenced standards. Employment of the CTA does not relieve the Contractor of providing the required Quality Control program.
- D. When inspections or tests by the CTA prove that the item or material does not meet all applicable specifications and requirements, the cost incurred for the re-testing or re-inspection shall be borne by the Contractor as per this Section.
- E. Samples will only be considered if taken at random. The Contractor shall permit representatives of the City to witness the selection of samples. Inspection or tests of items or materials that fail shall be sufficient cause to terminate further inspections/tests of the same brand, make or source of that product.
- F. The Contractor is obligated to correct any item deemed deficient at no additional cost to DEN.

#### 1.3 SUBMITTALS

- A. All submittals shall comply with requirements of Sections 013300 "Submittal

Procedures" and 013325 "Shop and Working Drawings, Product Data and Samples" for submittal requirements.

#### 1.4 CONTRACTOR SUBMITTAL OF PROPOSED TESTING AGENCIES

- A. The Contractor shall employ the services of a CTA that has been accredited by AASHTO or CCRL or an approved equal to perform the tests required in the Contract. The CTA may also provide technicians to perform the required inspections. However, inspection and testing cannot be performed simultaneously by the same technician. The Contractor shall receive written acceptance from the DEN Project Manager of the CTA prior to any permanent work being installed or tested.
- B. The Contractor shall not submit for acceptance to the DEN Project Manager any testing agency or laboratory utilized in the design or construction document preparation or presently employed by DEN as part of DEN Quality Assurance, Material Testing, or special inspection agencies.
- C. For consideration of acceptance, the Contractor shall submit to the DEN Project Manager the following items received from the CTA:
  - 1. Affidavit of current accreditation from a national certification and/or accreditation programs.
  - 2. Evidence that the CTA Laboratory is accredited to perform the testing required in the Contract Documents.
  - 3. Resumes and evidence of professional engineer registration and licensing in the State of Colorado for the personnel reviewing and signing test reports.
  - 4. Resumes and current certifications verifying that CTA management and supervisory personnel, laboratory staff, field testing technicians, and inspecting technicians are qualified in accordance with ASTM C 1077, D 3666, D 3740, and E 329 requirements to perform the Work. NICET, ACI, WAQTC, LabCAT, CDOT, NRMCA, PCA, AWS, ASNT certifications or a degree in a related engineering field with construction field experience that can demonstrate qualifications. A list summarizing all management, supervisory, laboratory, field testing, and inspection personnel assigned to the Project including the testing and/or inspection each individual will be performing, certifications held by each individual, and the expiration date of each certification.
  - 5. A matrix indicating each technical specification section, paragraph, quantity and type of sampling and/or testing required.
  - 6. Copies of all laboratory, field testing, and inspection report forms.

#### 1.5 SUBMITTAL OF REPORTS

- A. Test results shall be submitted by the Contractor to the DEN Project Manager after completion of inspections/tests by the CTA and prior to incorporation of the items into the Work unless the test or inspection must be done during or after installation.
- B. All field test results including but not limited to fresh concrete properties and in-place moisture-density shall be reported in legible draft form to the DEN Inspector

immediately at the test site. Any failing test shall be reported separately to the DEN Inspector or DEN Project Manager. The draft test results shall also be attached to the Daily Quality Control Inspection Report (reference Section 014510 "Contractor Quality Control") and transmitted to the DEN Project Manager the next workday.

- C. Typed test reports shall be provided to the DEN Project Manager as specified in the "Weekly Reports" Article in this Section. The test reports shall be numbered sequentially in chronological order. Individual tests shall be numbered sequentially. The reports and tests shall also be organized per specification section. All test results must be reviewed and signed by a registered licensed engineer in the State of Colorado. The signature represents that the test procedures used are in strict conformance with the applicable testing standard, the calculated data are true and accurate, the tools and equipment used were in calibration, the sample was not contaminated and the persons running the test were qualified.
- D. Reports of inspections and test activities are record documents and shall be maintained in a manner that provides integrity of item identification, acceptability, and traceability. Reports shall identify the following:
1. Contractor's name.
  2. DEN Contract number and title.
  3. Material Testing Agency name.
  4. Name of items inspected/tested including a physical description and, as applicable, model and make.
  5. Quantity of items.
  6. Inspection/test procedure used. If national standards are used, any deviation from these standards.
  7. Date the sample was taken and the date the test was made.
- E. Location (by coordinates, building grid or station number and elevation) of where tests and/or samplings were performed including environmental condition where applicable. Include plan drawing indicating location of test, lot size and location and work item sampled or tested.
1. Name of inspector/tester.
  2. In the event the testing or sampling is a re-test or re-sampling, reference the previous respective testing or sampling report.
  3. Specified requirements in the Contract that the item must meet. Include reference to technical specification section and paragraphs.
  4. Acceptability.
  5. Deviations/nonconformance.
  6. Evaluation of results.
  7. All information required for the specific test as specified in the applicable ASTM standard.
  8. Signature of authorized evaluator.

## 1.6 WEEKLY SUMMARY REPORTS

- A. The CTA and Quality Control Manager shall prepare and submit to the DEN Project



Manager a weekly summary report each week, which summarizes by specification section all work activities and results for the quality control tests and inspections conducted during that period. The weekly summary report shall be submitted within two (2) weeks from the end of the reporting period. At a minimum, the weekly summary report shall identify all inspections, test types, test locations, testers, test results, specifications, whether the test passed or failed, quantity of materials placed and the number of tests performed for each material, and the material supplier, installer and Contractor. Re-tests shall be identified in a fashion that easily correlates to the failing test. Any failed tests that have not been corrected when the report is published shall be highlighted and noted in the cover letter of the report.

- B. The weekly report shall be submitted per Sections 013000 and 013350 requirements.

## **PART 2 - PRODUCTS (Not Used)**

## **PART 3 - EXECUTION**

### **3.1 REMOVAL OF NONCONFORMING MATERIAL**

- A. The Contractor is obligated to correct or remove nonconforming materials, whether in place or not. If necessary, the DEN Project Manager will send written notification to the Contractor to correct or remove the defective materials from the project. If the Contractor fails to respond, the DEN Project Manager may order correction, removal, and/or replacement of defective materials by others, in which case the Contractor shall bear all costs incurred by such actions.

### **3.2 PERFORMANCE**

- A. If the DEN Project Manager determines that the CTA or its personnel are not effectively enforcing or performing the testing and documentation requirements specified in the Contract, the DEN Project Manager will require, in writing, the Contractor to remove and replace CTA or such personnel at no cost to DEN.

### **3.3 CONTROL OF MEASURING AND TEST EQUIPMENT**

- A. The CTA shall select measuring and test equipment in such a manner as to provide proper type, range, accuracy, calibration, and tolerance for determining compliance with specified requirements. Measuring and test devices shall be calibrated, adjusted and maintained at prescribed intervals prior to use based upon equipment stability and other conditions affecting measurement. Provisions shall be made for the proper handling and storage of equipment. Calibration shall be accomplished using certified standards that have a known traceable relationship to the National Institute of Standards and Technology. Every calibrated measuring and test device shall show the current status, date of last calibration and the due date for the next calibration. Calibration records shall be maintained onsite as quality records and shall be made available for inspection upon the DEN Project Manager's request.

## **PART 4 - MEASUREMENT**

### 4.1 METHOD OF MEASUREMENT

- A. No separate measurement shall be made for work under the Section.

## **PART 5 - PAYMENT**

### 5.1 METHOD OF PAYMENT

- A. No separate payment will be made for work under this Section.
- B. Refer to Title 17 - Inspection and Defects of the General Contract Conditions, 2011 Edition, for guidance on payment methods.

END OF SECTION **014525**



---

## SECTION 014545 - SPECIAL INSPECTION AGENCY AND OWNER TESTING AGENCIES

### PART 1 - GENERAL

#### 1.1 RELATED DOCUMENTS

- A. Drawings and general provisions of the Contract, including General and Special Conditions and other Division 01 Specification Sections, apply to this Section.
- B. Special Inspection Statement issued as part of the application for building permit for the specific task or project.

#### 1.2 SUMMARY

- A. The City will employ the services of Special Inspection Agencies (SIA). This Section identifies the requirements for the Contractor to coordinate, facilitate, and support DEN and its agents and consultants to fulfill the requirements of Special Inspection.
  - 1. Any additional tests deemed necessary by the Building Official, Engineer of Record, Special Inspector or DEN Project Manager to assure these agencies that all material and work on the Project meet the requirements of the Contract and all applicable codes and regulations.
  - 2. Minimum Laboratory and field testing requirements to be conducted by the SIA for materials and construction on this Project are included in the Table at the end of this Section.
  - 3. All caissons and piers drilling on this Project shall be continuously inspected by Special Inspection Agency hired by DEN directly or through the Engineer of Record or its sub-consultants.
  - 4. The Contractor shall not perform any work that could cover work or material that has not passed the requirement of special inspection or require the presence of the special inspector to meet the requirements of continuous or periodic inspection.
  - 5. It is the responsibility of the Contractor to plan, coordinate all testing requirements on the project to assure no delays are occurring due to the lack of inspection or testing.
  - 6. The Contractor must allow sufficient time in the schedule to perform all required inspection and testing.
  - 7. All rework due to nonconformance, failing tests or rework to test covered work prior to proper inspection and testing shall be borne by the Contractor.
  - 8. All re-inspections and re-testing costs due to non-conformances or failing tests or revisiting to test covered or incomplete work shall be borne by the Contractor at a cost of \$100 per hour in addition to all direct and indirect costs associated with testing.
  - 9. Periodic welding inspection shall include the minimum of fitting inspection and final inspection at all times.
  - 10. Inspections and tests conducted by the SIA shall not relieve in any way the

Contractor of the Contractor's responsibility and obligation to meet all specifications and referenced standards. Employment of the SIA does not relieve the Contractor of providing the required Quality Control program.

11. When inspections or tests by the SIA prove that the item or material does not meet all applicable specifications and requirements, the cost incurred for the re-testing or re-inspection shall be borne by the Contractor. Reference Article 5.1 of this Section.
12. Samples will only be considered if taken at random. The Contractor shall permit representatives of the City to witness the selection of samples. Inspection or tests of items or materials that fail shall be sufficient cause to terminate further inspections/tests of the same brand, make or source of that product.
13. The Contractor is obligated to correct any item deemed deficient at no additional cost to DEN.

### 1.3 SUBMITTALS

- A. All submittals shall comply with requirements of Section 013300 "Submittals" and Section 013325 "Shop and Working Drawings, Product Data and Samples" for submittal requirements.

### 1.4 CONTRACTOR SUBMITTAL OF PROPOSED CONTRACTOR'S TESTING AGENCIES

- A. Projects requiring Special Inspection where the Contractor is utilizing certified shop to produce material. DEN requires that testing be performed to satisfy the certification be no less than the following: All material and workmanship meets the requirements of a Contractor Material Testing Agency.
- B. The Contractor shall employ the services of a Testing Agency for process control and acceptance by the subcontractors and suppliers or material delivery for Contractor convenience or contractual obligations with others.
- C. The Contractor's Testing Agency must be accredited agency to perform any test required to be submitted for compliance with a Contract requirement or for use of data by DEN agencies for any official use, for examples and not to grant any obligation on the DEN Project Management Team, any payment reduction factor calculation. Any dispute or requirement to recalibrate testing equipment or machine, proof of compliance of material that was installed in contrary to manufacturer recommendation, any apparent defect due to adverse weather, improper installation, incomplete material record.
- D. Contractor's testing agency must be a qualified entity that has performed testing on similar jobs in size and complexity and has been accredited by AASHTO or CCRL or an approved equal to perform the tests required in the Contract. The CTA may also provide technicians to perform the required inspections. However, inspection and testing cannot be performed simultaneously by the same technician.
- E. The Contractor shall not submit for acceptance to the DEN Project Manager any

testing agency or laboratory utilized in the design or construction document preparation or presently employed by DEN as part of DEN Quality Assurance.

- F. For consideration of acceptance, the Contractor shall submit to the DEN Project Manager the following items received from the CTA:
1. Affidavit of current accreditation from a national certification and/or accreditation program.
  2. Evidence that the CTA Laboratory is accredited to perform the testing required in the Contract Documents.
  3. Resumes and evidence of professional engineer registration and licensing in the State of Colorado for the personnel reviewing and signing test reports.
  4. Resumes and current certifications verifying that SIA management and supervisory personnel, laboratory staff, field testing technicians, and inspecting technicians are qualified in accordance with ASTM C 1077, D 3666, D 3740, and E 329 requirements to perform the Work. NICET, ACI, WAQTC, LabCAT, CDOT, NRMCA, PCA, AWS, ASNT certifications, or a degree in a related engineering field with construction field experience can demonstrate qualifications. A list summarizing all management, supervisory, laboratory, field testing, and inspection personnel assigned to the Project including the testing and/or inspection each individual will be performing, certifications held by each individual, and the expiration date of each certification.
  5. A matrix indicating each technical specification section, paragraph, quantity and type of sampling and/or testing required.
  6. Copies of all laboratory, field testing, and inspection report forms.

## 1.5 SUBMITTAL OF REPORTS

- A. Test results shall be submitted by the Special Inspector and/or DEN Testing Agency to the DEN Project Manager after completion of inspections/tests by the SIA/OTA and prior to incorporation of the items into the Work unless the test or inspection must be done during or after installation.
- B. All field test results including but not limited to fresh concrete properties and in-place moisture-density shall be reported in legible draft form to the DEN/PMT Inspection and the Contractor Quality Control Manager immediately at the test site. Any failing test shall be reported separately to the DEN/PMT Inspector or DEN Project Manager within two (2) hours after the discovery.
- C. The Contractor's Quality Control Manager or his/her Authorized representative must keep track and official record of all tests passed, failed, or defected. The Contractor shall be fully responsible to show passing tests of all required elements. The lack of any passing test record of any required element does not waive the requirement to of testing or inspection as required by the Contract Documents and the IBC. The Contractor shall bear all costs associated with recovering missing tests including but not limited to the cost of the cost of disassembling, testing or inspecting, reassembling, and any indirect time or cost impacts of a missing required test or inspection.
- D. Typed test reports shall be provided by the testing agency to the DEN Project Manager

as specified in Part 1 of this Section Weekly Summary Reports. The test reports shall be numbered sequentially in chronological order. Individual tests shall be numbered sequentially. The reports and tests shall also be organized per specification section. All test results must be reviewed and signed by a registered licensed engineer in the State of Colorado. The signature represents that the test procedures used are in strict conformance with the applicable testing standard, the calculated data are true and accurate, the tools and equipment used were in calibration, the sample was not contaminated and the persons running the test were qualified.

- E. A plan of work and administrative procedure shall be established to assure that all test and inspections frequency required are performed and all defects are tracked and retested and re-inspected to meet all applicable specifications, codes, and standards.
- F. The Contractor shall track all tests performed on the daily reports and shall submit a statement for each phase of the Work showing all elements of Quality have been completed and all defects are addressed or scheduled to be addressed prior to covering the Work.
- G. Reports of inspections and test activities are record documents and shall be maintained in a manner that provides integrity of item identification, acceptability, and traceability. Reports shall identify the following:
  - 1. Contractor's name.
  - 2. DEN Contract number and title.
  - 3. Testing Agency name.
  - 4. Name of items inspected/tested including a physical description and, as applicable, model and make.
  - 5. Quantity of items.
  - 6. Inspection/test procedure used. If national standards are used, any deviation from these standards.
  - 7. Date the sample was taken and the date the test was made.
  - 8. Location, by coordinates, building grid or station number, of where tests and/or samplings were performed including environmental condition where applicable. Include plan drawing indicating location of test and work item sampled or tested.
  - 9. Name of inspector/tester.
  - 10. In the event the testing or sampling is a re-test or re-sampling, reference the previous respective testing or sampling report.
  - 11. Specified requirements in the Contract that the item must meet. Include reference to technical specification section and paragraphs.
  - 12. Acceptability.
  - 13. Deviations/nonconformance.
  - 14. Corrective action.
  - 15. Evaluation of results.
  - 16. All information required for the specific test as specified in the applicable ASTM standard.
  - 17. Signature of authorized evaluator.

## 1.6 WEEKLY SUMMARY REPORTS

- A. The SIA/OTA shall prepare and submit to the DEN Project Manager a weekly summary report each week that summarizes by specification section all work activities and results for the quality control tests and inspections conducted during that period.
- B. The weekly summary report shall be submitted within two (2) weeks from the end of the reporting period. At a minimum, the weekly summary report shall identify all inspections, test types, test locations, testers, test results, specifications, whether the test passed or failed, quantity of materials placed and the number of tests performed for each material, and the material supplier, installer and Contractor.
- C. Re-tests shall be identified in a fashion that easily correlates to the failing test. Any failed tests that have not been corrected when the report is published shall be highlighted and noted in the cover letter of the report. The SIA shall identify costs of re-testing or additional site visits required due to scheduling changes by the Contractor. A current Corrective Action Report log (CAR) shall also be included in the weekly summary report.
- D. The weekly report shall be submitted per Section 013300 "Submittal Procedures" and Section 013325 "Shop and Working Drawings, Product Data and Samples" requirements.

## **PART 2 - PRODUCTS (Not Used)**

## **PART 3 - EXECUTION**

### 3.1 CORRECTION OR REMOVAL OF NONCONFORMING MATERIAL

- A. The Contractor is obligated to correct or remove nonconforming materials, whether in place or not. If necessary, the DEN Project Manager will send written notification to the Contractor to correct or remove the defective materials from the Project. If the Contractor fails to respond, the DEN Project Manager may order correction, removal, and/or replacement of defective materials by others, in which case the Contractor shall bear all costs incurred by such actions.

### 3.2 PERFORMANCE

- A. If the DEN Project Manager determines that the SIA or its personnel are not effectively enforcing or performing the testing and documentation requirements specified in the Contract, the DEN Project Manager will, state in writing, the requirement for the Contractor to remove and replace SIA or such personnel at no cost to DEN.



### 3.3 CONTROL OF MEASURING AND TEST EQUIPMENT

- A. The SIA shall select measuring and test equipment in such a manner as to provide proper type, range, accuracy, calibration, and tolerance for determining compliance with specified requirements. Measuring and test devices shall be calibrated, adjusted and maintained at prescribed intervals prior to use based upon equipment stability and other conditions affecting measurement.
- B. Provisions shall be made for the proper handling and storage of equipment. Calibration shall be accomplished using certified standards that have a known traceable relationship to the National Institute of Standards and Technology. Every calibrated measuring and test device shall show the current status, date of last calibration and the due date for the next calibration. Calibration records shall be maintained onsite as quality records and shall be made available for inspection upon the DEN Project Manager's request.

## **PART 4 - MEASUREMENT**

### 4.1 METHOD OF MEASUREMENT

- A. No separate measurement shall be made for Work under the Section. DEN Project Management Team staff will track all costs and remark the conditions and track all associated impacts for credits to the City. The contractor record of the same is only valid if signed by the DEN Project Manager or authorized representative.

## **PART 5 - PAYMENT**

### 5.1 METHOD OF PAYMENT

- A. No separate payment will be made for Work under this Section.
- B. Refer to Title 17 - Inspection and Defects in the General Contract Conditions, 2011 Edition, for guidance on payment methods.

## **END OF SECTION 014545**

## **SECTION 015050 - MOBILIZATION**

### **PART 1 - GENERAL**

#### 1.1 RELATED DOCUMENTS

- A. Drawings and general provisions of the Contract, including General and Special Conditions and other Division 01 Specification Sections, apply to this Section.
- B. Section 012910 "Schedule of Values"

#### 1.2 SUMMARY

- A. The Work specified in this Section consists of preparatory work and operations including, but not limited to the following:
  - 1. Those necessary for the movement of personnel, equipment, supplies, and incidentals to the work site.
  - 2. For the establishment of all offices, buildings and other facilities necessary for the Work on the Project.
  - 3. For all other work and operations that must be performed or costs incurred prior to beginning work on the various Contract items on the work site.

#### 1.3 SUBMITTALS

- A. Refer to Section 013300 "Submittal Procedures" and Section 013325 "Shop and Working Drawings, Product Data and Samples" for submittal procedures.
- B. Submit a Mobilization Schedule a minimum of fourteen (14) days prior to first billing for mobilization.

#### 1.4 DELIVERY

- A. Delivery to the work site of construction tools, equipment, materials, and supplies shall be accomplished in conformance with all local governing regulations.

### **PART 2 - PRODUCTS**

#### 2.1 PRODUCTS

- A. Provide construction tools, equipment, materials, and supplies of the type and quantities that will facilitate the timely execution of the Work.

### **PART 3 - EXECUTION**

#### 3.1 EXECUTION AND REMOVAL

- A. Provide personnel, products, construction materials, equipment, tools, and supplies at the work site at the time they are required and scheduled to be installed or utilized.

### **PART 4 - MEASUREMENT**

#### 4.1 METHOD OF MEASUREMENT

- A. Refer to Section 013210 - Schedule, for details regarding mobilization scheduling, billing, and payment.

### **PART 5 - PAYMENT**

#### 5.1 METHOD OF PAYMENT

- A. Refer to Article 1104 - Changes in the Work, Contract Price or Contract Time of the General Contract Conditions, 2011 Edition.

END OF SECTION **015050**

## SECTION 015210 - TEMPORARY FACILITIES

### PART 1 - GENERAL

#### 1.1 RELATED DOCUMENTS

- A. Drawings and general provisions of the Contract, including General and Special Conditions and other Division 01 Specification Sections, apply to this Section.

#### 1.2 SUMMARY

- A. Section includes requirements for temporary utilities, support facilities, and security and protection facilities.
- B. Related Requirements:
  - 1. Section 011000 "Summary" for work restrictions and limitations on utility interruptions.
  - 2. Section 312319 "Dewatering" for disposal of ground water at Project site.
  - 3. Section 321216 "Asphalt Paving" for construction and maintenance of asphalt pavement for temporary roads and paved areas.
  - 4. Section 321313 "Concrete Paving" for construction and maintenance of cement concrete pavement for temporary roads and paved areas.

#### 1.3 DESCRIPTION

- A. The Work specified in this Section consists of furnishing, installing, operating, maintaining, and removing temporary construction barriers, enclosures, and field facilities including the Contractor's construction offices, staging areas, yards, storage areas, electrical power, telephone, water, fire protection, and sanitary service.
- B. Construction Offices, Construction Yards and Storage Areas:
  - 1. The Contractor's offices, construction yards laydown and storage areas shall be located as shown on the Contract Drawings and/or as designated by the DEN Project Manager. All construction offices, staging areas, and material storage areas are to occur within these areas.
  - 2. Any activity that is expected to result in disturbance of the ground surface equal to or greater than one acre or part of a larger project that is expected to disturb equal to or greater than one acre, is required to be identified in their Erosion Control permit. These areas include, but are not limited to, laydowns, borrow areas, stockpiles, and storage areas regardless of the location.
  - 3. All areas of ground disturbance are required to be stabilized in accordance with State, local, and airport rules and regulations prior to permit termination and/or closure of the Contract.
  - 4. The Contractor shall restore any area on DEN property that becomes

- contaminated as a result of its operations in accordance with Airport Rule and Regulation 180. Restoration shall be either to applicable standards under Federal and State law or to such other levels as may be required by the Manager of Aviation, at the Manager's sole discretion.
5. All temporary facility sites must be inspected prior to Contract closeout.
    - a. The DEN Project Manager or authorized representative shall conduct an inspection of contractor areas used during the life of the project. These areas include but are not limited to, staging areas, laydown areas, borrow areas, and contractor yards and offices.
  6. The DEN Project Manager will ensure these areas have been properly stabilized in accordance with DEN Rules and Regulations and required permits. Site must be restored to the condition in which the City initially provided to the Contractor. A representative from DEN Environmental Services shall be present during the final walk through.
  7. Contractor materials shall be managed in accordance with all applicable Environmental Regulations.
  8. Temporary facilities which the Contractor desires to locate in secondary laydown and staging areas adjacent to the Work or within the project limits are subject to approval by the DEN Project Manager. If approved, these areas must also be included as part of their erosion control permit.
  9. Access to and security of the Contractor's construction offices, yard, temporary facilities, and storage areas shall be as shown on the Contract Drawings or as specified in the Contract Special Conditions.
  10. Contractor Field Office:
    - a. The Contractor shall acquire all necessary permits for installation and construction work related to the Contractor's field office and fencing.
    - b. The Contractor shall provide, as part of the Contractor's on-site field office, a conference room for weekly meetings. Minimum size to accommodate **fifteen (15)]** people with the currently approved schedule posted on a wall. The conference room shall have **network connection with a monitor** and **one (1)** available telephone.
    - c. Jack the mobile office unit off its wheels and provide support. Enclose the underside of the trailer with weatherproof skirting.
    - d. Install tie downs in compliance with all applicable codes.
    - e. Provide access to the field office and easily accessible space for parking **six (6)** full size passenger automobiles as a minimum. Grade the field office site, access roadway, and parking area for drainage, and surface with gravel paving or crushed stone.
    - f. Water and sewer lines to the field office, if installed, shall be installed so they will not freeze.
  11. All Contractor Storage Yards must be fenced. Submit fencing plan and typical details to DEN Project Manager at least seven (7) days before planned execution for review and acceptance.
  12. In accordance with Denver Fire Department Requirements, all Temporary Facilities shall have signage that lists the following information:

- a. Company Name
- b. Contact Telephone Number
- c. Facility Address

C. Electrical Service

1. Provide lighting and power for field offices, storage facilities and other construction facilities and areas.
2. Provide power centers for electrically operated and controlled construction facilities including tools, equipment, testing equipment, interior construction lighting, heating, cooling and ventilation equipment.
3. Provide night security lighting at secured areas within construction limits at offices, storage facilities, temporary facilities and excavated areas.
4. Provide battery operated or equivalent emergency lighting facilities at construction areas where normal light failures would cause employees to be subjected to hazardous conditions. Test such facilities monthly and maintain a record of these tests for the DEN Project Manager's review.
5. Contractor shall bear all costs of temporary electric service permits, fees, and deposits required by the governing authorities, and connection charges and temporary easements including installation, maintenance, and removal of equipment.

D. Telephone/Communications Service:

1. The Contractor shall furnish, install, and maintain at least two (2) telephones in the Contractor's main field office. These phones shall be manned at all times by the Contractor's personnel or by an answering machine when personnel are not in the field office.
2. Comply with requirements of Division 26 Sections.

E. Water Service:

1. The Contractor shall make all connections and extensions required and shall make use of water in direct support of the Work. The Contractor shall install an approved Water Department tap at the City's water source prior to obtaining any water. The Contractor shall arrange and pay for its supply/distribution system from the City's point of connection. The location and alignment of the Contractor's temporary supply/distribution system must be approved by the DEN Project Manager prior to its installation. The Contractor shall leave in place all above ground and underground water distribution facilities unless otherwise directed by the DEN Project Manager.
2. The Contractor shall not use in place fire hydrants or standpipes as sources for construction water or potable water.
3. Comply with requirements of Division 22 Sections.

F. Fire Protection:

1. Furnish, install, and maintain temporary portable fire protection equipment throughout the construction period at all buildings (including the project site), maintenance shops, and fuel storage on all large construction equipment and at

- the location of any flammable materials or construction materials.
2. Comply with requirements of Division 21 Sections.

G. Sanitary Service:

1. Furnish, install, and maintain temporary sanitary facilities and services throughout the construction period.
2. Ensure that separate or single user toilets shall be provided to ensure privacy between the sexes.
3. Provide general washing facilities adequate for the number of employees.
4. Provide special washing facilities adequate for the number of employees engaged in the application of paints, coating, and other volatile or hazardous materials.

1.4 SUBMITTALS

- A. Refer to Section 013300 "Submittal Procedures" and Section 013325 "Shop and Working Drawings, Product Data and Samples" for submittal procedures.
- B. Submit a shop drawing within five (5) days of the Notice to Proceed that shows the following:
  1. Temporary facilities equipment and materials (include manufacturer's literature).
  2. Details and layout of temporary installations including fences, roads, parking, buildings, storage areas, signage, and drainage plans.
  3. Lighting plan showing temporary lighting facilities, electrical service panel location, electrical circuit diagram, and anticipated light level on the working roadway, pathway, or construction surface.
  4. As-built description of any temporary underground utilities referenced to the Airport grid and benchmark system within five (5) days of completion of the installation.
  5. Copies of all permits for all temporary facilities.

1.5 QUALITY CONTROL

- A. Provide products for, and the execution of, the Work of this Section that will satisfy the requirements of all applicable codes. Provide products that satisfy the requirements of the applicable codes.

**PART 2 - PRODUCTS**

2.1 ELECTRICAL SERVICE

- A. Provide temporary power and lighting equipment consisting of fixtures, transformers, panel boards, groundings, lamps, switches, poles, conduits and wiring sized and capable of continuous service and having adequate capacity to ensure a complete operating system. Comply with NEMA and Division 26 requirements.

## 2.2 TELEPHONE/COMMUNICATIONS SERVICE

- A. Provide equipment that is compatible with that of the current DEN service provider and the telephone exchange to which the Contractor connects.

## 2.3 POTABLE WATER SERVICE

- A. Provide sanitary materials and equipment that satisfies the requirements of codes and regulations pertaining to temporary water systems. Bottled products may be used if those products comply with codes. Clearly label portable containers having a dispensing tap and used only for drinking water. Provide single service disposable cups and a sanitary container for dispensing cups. A trash receptacle shall be provided and maintained beside each portable water supply.
- B. If paints, coatings and other volatile or hazardous materials injurious to humans will be applied as part of the Contract, provide washing facilities with warm water of approximately 120 degrees F.

## 2.4 FIRE PROTECTION

- A. Fire extinguishers shall be UL rated and shall comply with the International Fire Code with City of Denver amendments.

## 2.5 SANITARY SERVICE

- A. Provide materials and equipment adequate for the intended purposes, which will neither create unsanitary conditions nor violate the codes applicable to temporary sanitary facilities. Enclosures for toilet and washing facilities shall be weatherproof, sight proof, ventilated and sturdy, and shall be maintained in clean conditions.
- B. Provide portable type toilet facilities that satisfy the requirements of OSHA.
- C. Provide washing facilities as needed. Furnish soap, single-service paper towels, towel dispenser, and towel receptacle.

## **PART 3 - EXECUTION**

### 3.1 ELECTRICAL SERVICE

- A. The approximate location of primary power lines is shown on the Construction Drawings. The Contractor shall locate electrical service where it will not interfere with equipment, storage spaces, traffic, and prosecution of the Work or the work of others. Installation shall present a neat and orderly appearance and shall be structurally sound. Maintain service in a manner that will ensure continuous electrical service and safe working conditions.



- B. Comply with requirements of Division 26 Sections.

### 3.2 TELEPHONE/COMMUNICATION SERVICE

- A. Install temporary telephone service in a neat and orderly manner, and make structurally and electrically sound to ensure continuous service. Modify, relocate, and extend, as work progress requires. Place conduit and cable where those products will not interfere with traffic, work areas, materials, handling equipment, storage areas, and the work of other contractors. Service lines may be aerial.

### 3.3 WATER SERVICE

- A. Install the systems in a neat and orderly manner. Make them structurally and mechanically sound. Provide continuous service. Modify, relocate, and extend the systems as the Work progresses.
- B. Comply with requirements of Division 22 Sections.
- C. Locate systems where they will be convenient to work stations, sanitary facilities, and first aid station but will not interfere with traffic, work areas, materials handling equipment, storage areas, or the work of other contractors.
- D. Provide sanitary bubbler drinking fountains if potable water service is available. Disinfect water piping before using for the potable water service.
- E. Install vacuum breakers, backflow preventers, and similar devices in a manner and location that will prevent temporary water from returning to the water mains.
- F. Do not incorporate any part of temporary water distribution system into the permanent water distribution system.

### 3.4 FIRE PROTECTION

- A. Install products in conformance with the requirements of the applicable Denver Fire Department and OSHA regulations.
  - 1. Provide functional, approved fire extinguishers that are clearly identified for fire and an accessible supply of water during the period of construction. These fire extinguishers shall remain in place until permanent fire protection systems are functional.
- B. Instruct construction personnel as to location and use of temporary fire protection equipment.
- C. Comply with requirements of Division 21 Sections.

### 3.5 SANITARY SERVICE

- A. Place temporary sanitary and washing facilities in a neat and orderly manner within the limits of the Work and convenient to the workstations. Make these facilities structurally and mechanically sound. Modify, relocate, and extend the facilities as required by progress of the Work.
- B. Service toilets at those time intervals that will minimize the accumulation of wastes and prevent creation of unsanitary conditions, but not less than once a week.
- C. The waste from the sanitary and wash facilities shall be disposed of in accordance with all applicable rules, regulations, and laws and with the least environmental impact.

### 3.6 FENCING

- A. Contact all utility service companies prior to planning fence location and post locations for certification of current utilities. Locate pothole posts planned within five (5) feet of known utilities.

### 3.7 SIGNAGE

- A. Contractor shall not provide any signage for temporary facilities without prior approval from the DEN Project Manager.

### 3.8 REMOVAL

- A. The Contractor shall locate all temporary facilities including the underground utilities so they can be completely removed without damaging permanent work or the work site of other contractors.

## **PART 4 - MEASUREMENT**

### 4.1 METHOD OF MEASUREMENT

- A. No separate measurement shall be made for work under this Section.

## **PART 5 - PAYMENT**

### 5.1 METHOD OF PAYMENT

- A. No separate payment will be made for work under this section.

END OF SECTION 015210



## SECTION 015525 - TRAFFIC CONTROL

### PART 1 - GENERAL

#### 1.1 RELATED DOCUMENTS

- A. Drawings and general provisions of the Contract, including General and Special Conditions and other Division 01 Specification Sections, apply to this Section.

#### 1.2 SUMMARY

- A. The Work specified in this Section consists of furnishing plans and designs for traffic control and haul routes, implementing these plans with all necessary personnel and equipment. Installation may require but not be limited to signage, cones, flaggers, signal lights, lighting and temporary roads.
- B. All Work must be in conformance with the "Manual of Uniform Traffic Control Devices for Streets and Highways" (MUTCD) and CDOT Standard Plans regarding traffic control.
- C. The Contractor must coordinate the Contractor's proposed traffic control needs with the needs of other contractors on the airport construction site in writing through the DEN Project Manager.
- D. Refer to Article 805 – Protection of Street and Road System in the General Contract Conditions, 2011 Edition.

#### 1.3 QUALITY CONTROL

- A. Temporary signal work shall conform to CDOT Standard Plans and the current version of the CDOT Standard Specifications.
- B. Designate a qualified person to inspect and test traffic control devices daily and to ascertain that those devices are continuously operating, serviceable, in place, and clean.
- C. Provide certified personnel who will be responsible for design, implementation, and inspection of traffic control needs.

#### 1.4 SUBMITTALS

- A. Refer to Technical Specifications Sections 013300 "Submittals" and 013325 "Shop and Working Drawings, Product Data and Samples" for submittal procedures.
- B. Submit a Traffic Control Plan (TCP) that includes, at a minimum, the following list of

items for approval before starting Work. Submit an updated TCP when necessary to modify traffic operation or undertake a construction activity that creates a different traffic pattern:

1. Traffic blockade and reductions anticipated to be caused by construction operations.
  2. Temporary detours.
  3. A Method of Handling Traffic (MHT) must be submitted and approved by the DEN Project Manager, which at a minimum will show and describe proposed location, dates, hours, and duration of detours, vehicular traffic routing, and management, traffic control devices for implementing detours and details of barricades.
- C. Submit Haul Route Plan for both on- and off-site hauls. The Haul Route Plan shall be submitted 30 days prior to hauling any permanent material. The Plan shall be updated as the Contractor's plans change.
- D. Specific Traffic Considerations: The DEN Project Manager may require the Contractor to revise the Traffic Control Plan to address traffic considerations not included in the Contractor's plan.
- E. Shutdown requests for any impact to traffic must be submitted for approval a minimum of five days before the intended shutdown. These requests will be made through the DEN Project Manager.

## **PART 2 - PRODUCTS**

### **2.1 TRAFFIC CONTROL DEVICES**

- A. Devices including signs, delineators, striping, barriers, barricades, and high-level warning devices shall conform to the latest revision of the MUTCD and the latest revision of the Colorado Department of Transportation Standard Plans.

## **PART 3 - EXECUTION**

### **3.1 TEMPORARY TRAFFIC CONTROL DEVICES**

- A. Place temporary control devices in a manner that allows for the smooth flow of traffic at the posted speed limit, limiting hazards or abrupt changes in direction.
- B. Place traffic cones or delineators as directed by the MUTCD. Operate warning lights between sunset and sunrise.
- C. Place control devices so that approaching traffic is alerted to hazards and variances to normal traffic patterns.
- D. Clean and repair damaged devices or replace them with new devices as required.

### 3.2 TEMPORARY TRAFFIC STRIPING AND PAVEMENT MARKINGS

- A. Full-compliance striping is required at all times per the MUTCD.
- B. Temporary signs must be replaced with permanent signing within three days per the MUTCD.

### 3.3 FLAGGERS

- A. Furnish flaggers where required for safety and by the MHT.

### 3.4 CONSTRUCTION VEHICULAR TRAFFIC

- A. Restrict construction vehicles to approved haul routes.
- B. Haul routes on the airfield must be approved by Security.

### 3.5 CONTROLLING VEHICULAR AND PEDESTRIAN FLOW ADJACENT TO WORK SITE

- A. Ensure that construction operations will not impede normal traffic. Where work is in the area of pedestrian or occupant activity, the Contractor shall detail a plan for managing pedestrian traffic safely. Refer to Title 8 - Protection of Persons and Property, Section 801.1 in the General Contract Conditions, 2011 Edition.

### 3.6 SIGNS

- A. Refer to Title 8, Article 802 - Protective Devices and Safety Precautions in the General Contract Conditions, 2011 Edition.
  - 1. The Contractor must contact the DEN Project Manager a minimum of five (5) working days in advance of construction for installation, relocation, or removal of regulatory parking signs.
- B. Coordinate and pay any expense associated with the furnishing and installation of all parking regulatory signs, such as "No Stopping Any Time," etc., at the work site.
- C. Furnish and install any necessary advance detour or guidance signing.
- D. Authorize, modify, and install regulatory parking controls and vehicle turn restrictions.
- E. Implement those traffic control modifications outside of the traffic control zone that are necessary to manage diverted traffic.

#### **PART 4 - MEASUREMENT**

##### 4.1 METHOD OF MEASUREMENT

- A. No separate measurement shall be made for work under this Section.

#### **PART 5 - PAYMENT**

##### 5.1 PAYMENT

- A. Payment for Traffic Control under these schedules will be for work performed under the applicable unit price item or lump sum bid item.

END OF SECTION 015525

## SECTION 015719 - TEMPORARY ENVIRONMENTAL CONTROLS

### PART 1 - GENERAL

#### 1.1 RELATED DOCUMENTS

- A. Drawings and general provisions of the Contract, including General and Specifications Conditions and other Division 01 Specification Sections, apply to this Section.
- B. Title 8 - Protection of Persons and Property in the General Contract Conditions, 2011 Edition, specifically the following articles:
  - 1. Article 806 - Protection of Drainage Ways
  - 2. Article 807 - Protection of Environment
  - 3. Article 808 - Hazardous and Explosive Materials or Substances
  - 4. Article 809 - Archaeological and Historical Discoveries
- C. Denver Municipal Airport System Rules and Regulations, Part 180-Environmental Management.
- D. DEN Environmental Management System (EMS)

#### 1.2 SUMMARY

- A. The Work specified in this Section consists of identifying, and avoiding or mitigating adverse environmental impacts to air, water, soil, and other natural resources caused by construction activities.
  - 1. The Contractor, in conducting any activity on airport property or in conducting work for an airport project not on airport property, shall comply with all applicable airport, local, state, and federal rules, regulations, statutes, laws, and orders.
  - 2. Work shall not commence on any project until all FAA approvals have been received, applicable permits have been issued and signed by permittee, and all inspection requirements have been satisfied in accordance with State and local permitting requirements.

#### 1.3 SUBMITTALS

- A. Refer to Section 013300 "Submittal Procedures" and Section 013325 "Shop and Working Drawings, Product Data and Samples" for submittal procedures.
- B. Within ten (10) days after Notice to Proceed on a task order, the Contractor shall submit the following if applicable, unless waived by the DEN Project Manager:
  - 1. Submittals pertaining to water quality management:



- a. Construction Activities Stormwater Discharge Permit
  - 1) City and County of Denver
    - a) Sewer Use & Drainage Permit (SUDP)
    - b) Construction Activities Stormwater Discharge Permit (CASDP)
  - 2) Colorado Department of Public Health and Environment (CDPHE) Colorado Discharge Permit System (CDPS) Authorization to Discharge (Contractor need not submit a copy of the general permit or the general permit rationale)
    - a) CDPS General Permit for Stormwater Discharges Associated with Construction Activities
    - b) CDPS General Permit for Associated with Non-Extractive Industrial Activity
    - c) CDPS General Permit for Construction Dewatering Discharges (Prior to obtaining a CDPS General Permit for Construction Dewatering Discharges permit, the Contractor shall submit a draft permit application and the final permit application for DEN review and approval PRIOR to submittal to CDPHE. The Contractor need not submit a copy of the general permit or the general permit rationale.
  - 3) Upon request the contractor shall provide the following documentation
    - a) Stormwater Management Plan (SWMP)
    - b) CASDP Inactivation Request
    - c) CDPS Notice of Termination
    - d) Permit Transfer Application
    - e) Modification Application
    - f) Discharge Monitoring Reports (DMRs)
    - g) A copy of the well permit from the state Division of Water Resources for every new well that diverts or for the monitoring of groundwater. (A draft copy of the Notice of Intent for any borehole structure filed with the state Division of Water Resources).
    - h) Section 404 related permitting (Prior to obtaining a permit issued by the US Army Corps of Engineers, the contractor shall submit a draft copy of the application and coordinate with efforts DEN Environmental Services).
  - 4) Revisions or amendments to the CASMP by the Contractor: At the completion of the Project, after final stabilization has been achieved and accepted in accordance with CASDP requirements, the Contractor shall submit a copy of the CASDP Inactivation Request.
2. Submittals pertaining to sewage holding tanks associated with buildings and trailers: For purposes of this Section, the generic term "sewage holding tank"

means “individual sewage disposal system (ISDS)”, “privy vault”, “septic tank”, or “septic system”:

- a. Draft copy of the permit application for a sewage holding tank.
  - b. Copy of the Sewer Use & Drainage Permit issued by the Denver Department of Public Works.
  - c. Copy of the ISDS permit issued by the Denver Department of Environmental Health.
3. Submittals pertaining to air quality management:
- 1) Copy of any permit issued by the CDPHE Air Pollution Control Division (APCD)
4. Submittals pertaining to storage tanks and containers:
- a. Copy of the approved application issued by the State of Colorado, Department of Labor and Employment, Division of Oil and Public Safety, for installation of petroleum, or other regulated substances, storage tanks located on airport property and used for the Project.
  - b. Copy of permits issued by the Denver Fire Department for storage tank installations, storage tank removals, and hazardous materials use/storage.
  - c. Copy of Spill Prevention, Control, and Countermeasure (SPCC) Plan for petroleum storage tanks and containers with capacity of 55 gallons of oil or greater located on airport property and used for the Project.
5. Copies of any other plans, permits, permit applications, correspondence with regulatory agencies, including violations, waste manifests, results of laboratory analyses, or other environmental documentation required for the Project not previously identified herein.

#### 1.4 RELATED DOCUMENTS

- A. Code of Federal Regulations (CFR) Publications, including, but not limited to, the following:
1. 33 CFR 323 - Permits for discharges of dredged or fill materials into waters of the United States.
  2. 40 CFR - Protection of Environment.
  3. 49 CFR 171-180 Hazardous Materials Transportation Regulations.
- B. Colorado Revised Statutes, including, but not limited to, the following:
1. Water Quality Control, Title 25, Article 8.
  2. Air Quality Control, Title 25, Article 7.
  3. Hazardous Waste, Title 25, Article 15.
  4. Noise Abatement, Title 25, Article 12.
  5. Petroleum Storage Tanks, Title 8, Article 20.5.
  6. Liquefied Petroleum Gas (LPG) Storage Tanks, Title 8, Article 20, Part 4.

7. Solid waste regulations.
- C. City and County of Denver Executive Orders, including, but not limited to, the following:
    1. Executive Order No. 115 - Required Use of Denver-Arapahoe Disposal Site (Landfill).
    2. Executive Order No. 123 - Greenprint Denver Office and Sustainability Policy.
    3. Denver Revised Municipal Code, Title II, Sections 48-44 and 48-93 - Solid Waste.
  - D. City and County of Denver Construction Sites Program.
  - E. City and County of Denver Construction Activities Stormwater Management Plans Information Guide.
  - F. Any other applicable rules, regulations, ordinances, and guidance must be followed as applicable.
  - G. Refer to Section 013300 "Submittal Procedures" and 013325 "Shop and Working Drawings, Product Data and Samples" for submittal procedures.
  - H. Refer to Section 017419 "Construction Waste Management" for waste management requirements

## **PART 2 - PRODUCTS**

### 2.1 PRODUCTS

- A. Products required for the Work shall meet all Environmental Requirements.
- B. At a minimum, products for erosion and sediment control must conform to the technical requirements contained in the City and County of Denver "Construction Activities Stormwater Manual" and the current version of the "Urban Drainage and Flood Control District's Urban Storm Drainage Criteria Manual, Volume 3: Best Management Practices".

## **PART 3 - EXECUTION**

### 3.1 AIR POLLUTION CONTROLS

- A. The Contractor shall use appropriate control measures to comply with applicable air quality permit requirements. Additionally, the Contractor must be aware of the following procedures and techniques while conducting construction activities on DEN property.  
NOTE: Application of dust control measures should be discussed and outlined in the Dust Control Plan.

1. Apply water as needed to the construction site haul roads, disturbed surface areas and public access roads as needed to suppress dust. The use of chemical stabilizer can be requested by the Contractor. The type of stabilizer to be used and locations of use must be included in the Dust Control Plan, which must be approved by the DEN Project Manager prior to application.
2. The Contractor shall suspend all earthmoving activities if wind speed exceeds 30 mph. For purposes of this Section, the generic term "earthmoving" means clearing, grubbing, excavation, topsoil removal, backfilling, embankment work, grading, trenching, drilling, and installation of borings. Contractors are expected to check wind speeds with the airport's ramp tower to demonstrate compliance with this requirement. In addition, the Project may be shut down if two of three of the Runway Visual Range (RVR) instruments read visibility of 2,400 feet or less. The instruments are used by FAA Control Tower personnel to ensure safe aircraft operations. Costs for shutdowns due to wind velocities or RVR readings shall not be grounds for delay or extra cost claims.

B. Burning of materials is strictly prohibited on DEN property.

### 3.2 WATER POLLUTION CONTROLS

A. The Contractor shall conduct construction activities in accordance with all applicable permit requirements. In addition, the Contractor shall comply with the following procedures and requirements while conducting activities on DEN property:

1. Water encountered during construction cannot be discharged to the stormwater system or placed onto the ground surface without a permit AND prior written approval by the DEN Project Manager. If groundwater or stormwater is anticipated to be encountered and the Contractor desires to discharge it to the stormwater system or onto the ground surface, then the Contractor must obtain an appropriate CDPS discharge permit in advance of the discharge unless this activity is specifically authorized under the CDPS Construction Stormwater Permit.
2. If water is encountered and the Contractor desires to discharge these waters to the sanitary sewer system, then the Contractor must obtain approval from DEN Environmental Services in advance of the discharge.
3. The Contractor shall ensure that stormwater that comes in contact with storage areas does not become impacted and discharged to the stormwater sewer system or to an impervious surface. Furthermore, any materials in storage areas shall not be stored directly on the ground. Refer to Section 264200 "Cathodic Protection" for cathodic protection requirements.
4. The Contractor shall not operate any valves, sluice gates or other drainage appurtenances related to any DEN sewer system without the prior approval of both the DEN Project Manager and DEN Environmental Services. Any violation of this directive may result in the payment of a financial penalty by the Contractor if the State of Colorado assesses such a penalty.

### 3.3 EROSION CONTROL AND SEDIMENTATION CONTROL

- A. This Work consists of constructing, installing, maintaining and removing, if required, temporary and permanent control measures during the life of the Contract (and possibly afterward) until the Contractor achieves final stabilization of the site to prevent or minimize erosion, sedimentation, and pollution of any state waters in accordance with all Environmental Requirements.
- B. The Contractor is responsible for compliance with all requirements in accordance with the CASDP, the City and County of Denver Construction Sites Program, the approved CASMP, and CDPS-issued permits.
- C. Temporary facilities, including but not limited to storage areas, laydowns, borrow areas, and contractor offices and work yards, shall be managed in accordance with Section 015210 "Temporary Facilities".
- D. Clean soil fill may be stockpiled in any area that has been previously approved and signed off by the DEN Section Manager of Construction, Design and Planning, and Environmental Services. Soil stockpiles are considered a potential pollutant source and must be addressed in the CASMP and/or SWMP.
- E. Make immediately available, upon the DEN Project Managers request, all labor, material, and equipment judged appropriate by the DEN Project Manager to maintain suitable erosion and sediment control features. These actions requested by the DEN Project Manager take precedence over all other aspects of project construction that have need of the same labor, material and equipment, except those aspects required to prevent loss of life or severe property damage.

### 3.4 CONSTRUCTION OF CONTROL MEASURES FOR EROSION AND SEDIMENTATION

- A. The Contractor must install control measures in accordance with the most recent version of the "Urban Drainage and Flood Control District's Urban Storm Drainage Criteria Manual, Volume 3: Best Management Practices and the City and County of Denver Construction Activities Stormwater Manual".
  - 1. Deviations from these two documents are allowed with written consent from the City and County of Denver NPDES Inspector.

### 3.5 STORAGE OF OIL, FUELS, OR HAZARDOUS SUBSTANCES

- A. The Contractor shall prevent oil or other hazardous substances, as defined in federal and state regulations, from entering the ground, drainage or local bodies of water, and shall provide containment, diversionary structures, or equipment to prevent discharged oil from reaching a watercourse and take immediate action to contain and clean up any spill of oily substances, petroleum products, or hazardous substances. The Contractor shall provide one or more of the following preventive systems at each petroleum storage site:

1. Dikes, berms, or retaining walls capable of containing at least 100% of the volume of the largest single tank and equipped with sufficient freeboard to contain precipitation events. The secondary containment must be “sufficiently impermeable” to prevent a release to the environment.
  2. Culverting, curbing, guttering, or other similar structures capable of containing at least 100% of the volume of the largest single tank and freeboarding from precipitation.
- B. The provision of such preventive systems shall be subject to acceptance by the DEN Project Manager prior to tank installation and shall follow the SPCC regulations (40 CFR Part 112).
- C. Prior to bringing any containers of 55-gallon or above capacity onto DEN property for storage of oil, fuel, or other petroleum substances, the Contractor may be required to prepare an SPCC Plan that conforms to 40 CFR Part 112. The plan must include a certification either from a Professional Engineer or self-certification, if applicable, as well as management approval from the legally responsible Contractor representative.

### 3.6 SPILL RESPONSE AND NOTIFICATION

- A. The Contractor is responsible for all spills that may result from its activities. For ANY suspected or confirmed release or spill of oil, fuel, solid waste, hazardous waste, unknown materials, lavatory waste, or miscellaneous chemicals, etc., that occurs as the result of the Contractor’s activities on DEN property, the Contractor is required to take immediate action to mitigate the release or spill and report it to the DEN Project Manager and to the DEN Communications Center at (303) 342-4200.
- B. The Contractor is responsible for notifying the appropriate regulatory agency in the event suspected and/or confirmed releases are identified, in accordance with regulatory requirements.

### 3.7 SITE REMEDIATION AND RESTORATION

- A. The Contractor shall be required to perform any necessary site assessment and remediation activities required by applicable regulatory agency.
- B. During routine construction activities, the Contractor is required to manage soils using typical construction techniques. The Contractor must differentiate between soils and wastes, including contaminated soils versus clean soils, and determine those materials that can remain on DEN property and those that must be transported off site for disposal.
- C. During all construction activities that require the management of soils, the Contractor must notify the DEN Project Manager and DEN Environmental Services (ES) that soils being managed may be impacted by industrial activities conducted at the airport. “Process knowledge” pertaining to previous use and/or impact for the locations under construction can be used to determine whether impacted soils are probable. Also, common indices such as soil staining and odor can be used as a determination for the

probable condition. If probable contamination conditions are suspected, the Contractor will notify the DEN Project Manager and DEN ES immediately. At that time, which may be before the Work is initiated where indicative conditions exist, all work will cease until a sampling and analysis approach is determined and implemented by the proper responder.

- D. If the site conditions warrant based on evidence of spillage or contamination, process knowledge, and/or visual or olfactory observations, the Contractor may be required to conduct sampling and analysis to confirm that no remedial action is required. Prior to conducting any removal activities, the Contractor must provide a Scope of Work to the DEN Project Manager describing the proposed site assessment activities.
- E. The impacted project will modify its operation to include a segregation area where probable impacted soils can be placed, stored, and sampled for characterization. Should the soil materials be determined to exceed the applicable standards, the DEN Project Manager, in conjunction with DEN ES, will be responsible for the proper disposal of these materials. Materials that are determined to contain contamination levels below the applicable standards can be considered clean soils and placed back into the excavation or reused elsewhere on DEN property. In accordance with Part 3 of this Section, materials removed that are suitable for recycling will be placed within areas designated on DEN to store these materials.
- F. The Contractor shall restore any area on the Airport that becomes contaminated as a result of its operations. Restoration shall be either to applicable standards under federal and state law or to such other levels as may be required by the Manager of Aviation, at the Manager's sole discretion. Such restoration shall be completed at the earliest possible time, and the Contractor's restoration shall be subject to inspection and approval by the Manager of Aviation or duly authorized representative. See DEN Rules & Regulations - Part 180.

## **PART 4 - MEASUREMENT**

### **4.1 METHOD OF MEASUREMENT**

- A. No separate measurement shall be made for work under this Section.

## **PART 5 - PAYMENT**

### **5.1 METHOD OF PAYMENT**

- A. No separate payment will be made for work under this Section.
- B. The Contractor shall be responsible for payment of all fees associated with review of environmental permit applications and processing of environmental permits.

END OF SECTION 015719

## **SECTION 015810 - TEMPORARY SIGNS**

### **PART 1 - GENERAL**

#### **1.1 RELATED DOCUMENTS**

- A. Drawings and general provisions of the Contract, including General and Special Conditions and other Division 01 Specification Sections, apply to this Section.

#### **1.2 SUMMARY**

- A. Section includes requirements for the following:
  - 1. Construction signage visible to the public.
  - 2. Temporary directional, informational, or regulatory signage.
- B. Related Requirements:
  - 1. Section 015210 "Temporary Facilities" for requirements for temporary facilities.

#### **1.3 SUBMITTALS**

- A. Submit temporary sign finishes, materials and paint, etc., for review and approval by DEN Project Manager prior to any fabrication.

#### **1.4 QUALITY CONTROL**

- A. Construction and other temporary signage visible to the public must be commercial grade quality, professionally fabricated, and installed based on the location of the sign. The Contractor is responsible to maintain this signage until it is no longer needed, and to remove signage from the site.

### **PART 2 - PRODUCTS**

#### **2.1 GENERAL**

- A. Interior signs that are visible and not physically accessible to the public may be made of rigid board, such as "Gator Board", with vinyl messages. All edges must be finished and all fasteners concealed.
- B. Interior signs that are visible and physically accessible by the public must be vandal-proof. Acceptable examples of vandal-proof signs are messages applied second surface with concealed tamperproof fasteners.



- C. Exterior signs must be vandal-proof and fabricated of weatherproof materials.

### **PART 3 - EXECUTION**

#### 3.1 HARDWARE

- A. Interior Signs: Attach with suitable adhesive and/or tape which may be removed without damage to finishes.
- B. Exterior Signs: Must be secured to withstand site conditions and varying weather conditions.

#### 3.2 SIGN FINISHES, MATERIALS, AND PAINT

- A. Provide temporary signage to reflect permanent sign design and/or as directed by the DEN Signage Design Project Manager. Submit temporary sign finishes, materials and paint, etc., for review and approval prior to any fabrication.

#### 3.3 MAINTENANCE

- A. The Contractor shall maintain temporary signage until it is no longer needed, as determined by DEN Project Manager.

#### 3.4 REMOVAL

- A. The Contractor shall remove all temporary signs, and clean and refurbish affected areas to their original, or intended, condition.

### **PART 4 - MEASUREMENT**

#### 4.1 METHOD OF MEASUREMENT

- A. No separate measurement shall be made for work under this Section.

### **PART 5 - PAYMENT**

#### 5.1 METHOD OF PAYMENT

- A. No separate payment will be made for work under this Section.

## SECTION 016000 - PRODUCT REQUIREMENTS

### PART 1 - GENERAL

#### 1.1 RELATED DOCUMENTS

- A. Drawings and general provisions of the Contract, including General and Special Conditions and other Division 01 Specification Sections, apply to this Section.

#### 1.2 SUMMARY

- A. Section includes administrative and procedural requirements for selection of products for use in Project; product delivery, storage, and handling; manufacturers' standard warranties on products; special warranties; and comparable products.
- B. Related Requirements:
  - 1. Section 012510 "Substitutions" for requests for substitutions.
  - 2. Section 014225 "Reference Standards" for applicable industry standards for products specified.

#### 1.3 DEFINITIONS

- A. Products: Items obtained for incorporating into the Work, whether purchased for Project or taken from previously purchased stock. The term "product" includes the terms "material," "equipment," "system," and terms of similar intent.
  - 1. Named Products: Items identified by manufacturer's product name, including make or model number or other designation shown or listed in manufacturer's published product literature that is current as of date of the Contract Documents.
  - 2. New Products: Items that have not previously been incorporated into another project or facility. Products salvaged or recycled from other projects are not considered new products.
  - 3. Comparable Product: Product that is demonstrated and approved through submittal process to have the indicated qualities related to type, function, dimension, in-service performance, physical properties, appearance, and other characteristics that equal or exceed those of specified product.

#### 1.4 SUBMITTALS

- A. Comparable Product Requests: Submit request for consideration of each comparable product. Identify product or fabrication or installation method to be replaced. Include Specification Section number, title, and Drawing numbers and titles.
  - 1. Include data to indicate compliance with the requirements specified in "Comparable Products" Article.

2. DEN Project manager's Action: If necessary, DEN Project Manager will request additional information or documentation for evaluation within one week of receipt of a comparable product request. DEN Project Manager will notify Contractor of approval or rejection of proposed comparable product request within **15** days of receipt of request, or **seven (7)** days of receipt of additional information or documentation, whichever is later.
  - a. Form of Approval: As specified in Section 013300 "Submittal Procedures."
  - b. Use product specified if DEN Project Manager does not issue a decision on use of a comparable product request within time allocated.

## 1.5 QUALITY ASSURANCE

- A. Compatibility of Options: If Contractor is given option of selecting between two or more products for use on Project, select product compatible with products previously selected, even if previously selected products were also options.
  1. Each contractor is responsible for providing products and construction methods compatible with products and construction methods of other contractors.
  2. If a dispute arises between contractors over concurrently selectable but incompatible products, DEN Project Manager will determine which products shall be used.

## 1.6 PRODUCT DELIVERY, STORAGE, AND HANDLING

- A. Deliver, store, and handle products using means and methods that will prevent damage, deterioration, and loss, including theft and vandalism. Comply with manufacturer's written instructions.
- B. Delivery and Handling:
  1. Schedule delivery to minimize long-term storage at Project site and to prevent overcrowding of construction spaces.
  2. Coordinate delivery with installation time to ensure minimum holding time for items that are flammable, hazardous, easily damaged, or sensitive to deterioration, theft, and other losses.
  3. Deliver products to Project site in an undamaged condition in manufacturer's original sealed container or other packaging system, complete with labels and instructions for handling, storing, unpacking, protecting, and installing.
  4. Inspect products on delivery to determine compliance with the Contract Documents and to determine that products are undamaged and properly protected.
- C. Storage:
  1. Store products to allow for inspection and measurement of quantity or counting of units.
  2. Store materials in a manner that will not endanger Project structure.

3. Store products that are subject to damage by the elements, under cover in a weathertight enclosure above ground, with ventilation adequate to prevent condensation.
4. Protect foam plastic from exposure to sunlight, except to extent necessary for period of installation and concealment.
5. Comply with product manufacturer's written instructions for temperature, humidity, ventilation, and weather-protection requirements for storage.
6. Protect stored products from damage and liquids from freezing.
7. Provide a secure location and enclosure at Project site for storage of materials and equipment by Owner's construction forces. Coordinate location with Owner.

## 1.7 PRODUCT WARRANTIES

- A. Refer to Title 18 - Warranties, Guarantees and Corrective Work of the General Contract Conditions, 2011 Edition.
- B. Submittal Time: Comply with requirements in Section 017720 "Contract Closeout."

## PART 2 - PRODUCTS

### 2.1 PRODUCT SELECTION PROCEDURES

- A. General Product Requirements: Provide products that comply with the Contract Documents, are undamaged, and unless otherwise indicated, are new at time of installation.
  1. Provide products complete with accessories, trim, finish, fasteners, and other items needed for a complete installation and indicated use and effect.
  2. Standard Products: If available, and unless custom products or nonstandard options are specified, provide standard products of types that have been produced and used successfully in similar situations on other projects.
  3. Owner reserves the right to limit selection to products with warranties not in conflict with requirements of the Contract Documents.
  4. Where products are accompanied by the term "as selected," DEN Project Manager will make selection.
  5. Descriptive, performance, and reference standard requirements in the Specifications establish salient characteristics of products.
  6. Or Equal: For products specified by name and accompanied by the term "or equal," or "or approved equal," or "or approved," comply with requirements in "Comparable Products" Article to obtain approval for use of an unnamed product.
- B. Product Selection Procedures:
  1. Product: Where Specifications name a single manufacturer and product, provide the named product that complies with requirements. Comparable products or substitutions for Contractor's convenience will not be considered.
  2. Manufacturer/Source: Where Specifications name a single manufacturer or

source, provide a product by the named manufacturer or source that complies with requirements. Comparable products or substitutions for Contractor's convenience will not be considered.

3. Products:

- a. Restricted List: Where Specifications include a list of names of both manufacturers and products, provide one of the products listed that complies with requirements. Comparable products or substitutions for Contractor's convenience **will** be considered.
- b. Nonrestricted List: Where Specifications include a list of names of both available manufacturers and products, provide one of the products listed, or an unnamed product, that complies with requirements. Comply with requirements in "Comparable Products" Article for consideration of an unnamed product.

4. Manufacturers:

- a. Restricted List: Where Specifications include a list of manufacturers' names, provide a product by one of the manufacturers listed that complies with requirements. Comparable products or substitutions for Contractor's convenience **will** be considered.
- b. Nonrestricted List: Where Specifications include a list of available manufacturers, provide a product by one of the manufacturers listed, or a product by an unnamed manufacturer, that complies with requirements. Comply with requirements in "Comparable Products" Article for consideration of an unnamed manufacturer's product.

C. Visual Matching Specification: Where Specifications require "match DEN Project Manager's sample", provide a product that complies with requirements and matches DEN Project Manager's sample. DEN Project Manager's decision will be final on whether a proposed product matches.

1. If no product available within specified category matches and complies with other specified requirements, comply with requirements in Section 012510 "Substitutions" for proposal of product.

D. Visual Selection Specification: Where Specifications include the phrase "as selected by DEN Project Manager from manufacturer's full range" or similar phrase, select a product that complies with requirements. DEN Project Manager will select color, gloss, pattern, density, or texture from manufacturer's product line that includes both standard and premium items.

## 2.2 COMPARABLE PRODUCTS

A. Conditions for Consideration: DEN Project Manager will consider Contractor's request for comparable product when the following conditions are satisfied. If the following conditions are not satisfied, DEN Project Manager may return requests without action, except to record noncompliance with these requirements:

1. Evidence that the proposed product does not require revisions to the Contract Documents that it is consistent with the Contract Documents and will produce the indicated results, and that it is compatible with other portions of the Work.
2. Detailed comparison of significant qualities of proposed product with those named in the Specifications. Significant qualities include attributes such as performance, weight, size, durability, visual effect, and specific features and requirements indicated.
3. Evidence that proposed product provides specified warranty.
4. List of similar installations for completed projects with project names and addresses and names and addresses of architects and owners, if requested.
5. Samples, if requested.

## 2.3 MATERIALS

- A. General: Comply with requirements specified in other Sections.
- B. In-Place Materials: Use materials for patching identical to in-place materials. For exposed surfaces, use materials that visually match in-place adjacent surfaces to the fullest extent possible.
  1. If identical materials are unavailable or cannot be used, use materials that, when installed, will provide a match acceptable to DEN Project Manager for the visual and functional performance of in-place materials.

## **PART 3 - EXECUTION (Not Used)**

## **PART 4 - MEASUREMENT**

### 4.1 METHOD OF MEASUREMENT

- A. No separate measurement shall be made for work under this Section.

## **PART 5 - PAYMENT**

### 5.1 METHOD OF PAYMENT

- A. No separate payment will be made for work under this Section.

END OF SECTION **016000**



## **SECTION 016610 - STORAGE AND PROTECTION**

### **PART 1 - GENERAL**

#### 1.1 RELATED DOCUMENTS

- A. Drawings and general provisions of the Contract, including General and Special Conditions and other Division 01 Specification Sections, apply to this Section.

#### 1.2 SUMMARY

- A. The Work specified in this Section consists of providing storage and protection of the materials, products and supplies which are to be incorporated into the construction and indicating such storage areas on the working drawings with the location and dates when such areas will be available for each purpose.
- B. Related Requirements:
  - 1. Section 015210 "Temporary Facilities" for requirements for temporary facilities.

#### 1.3 SUBMITTALS

- A. Refer to Technical Specifications Sections 013300 "Submittal Procedures" and 013325 "Shop and Working Drawings, Product Data and Samples" for submittal procedures. Submit concurrently with submittals required in Section 013223 "Construction Layout, As-built and Quantity Surveys".
- B. Submit working drawings showing locations of storage areas not indicated on the Contract Drawings.
- C. Submit descriptions of proposed methods and locations for storing and protecting products.

### **PART 2 - PRODUCTS**

#### 2.1 MATERIALS

- A. Materials required for the storage and protection of the items specified shall be durable, weatherproof and either factory finished or painted to present an appearance acceptable to the DEN Project Manager and the City. Storage facilities shall be uniform in appearance with similar materials used to the maximum extent possible.



## **PART 3 - EXECUTION**

### **3.1 GENERAL REQUIREMENTS OF EXECUTION**

- A. Palletize materials, products, and supplies that are to be incorporated into the construction and stored off the ground. Material and equipment shall be stored only in those areas that are indicated as storage areas on the Contract Drawings and on the reviewed and accepted working drawings.
  - 1. Store these items in a manner which will prevent damage and which will facilitate inspection.
  - 2. Leave seals, tags, and labels intact and legible.
  - 3. Maintain access to products to allow inspection.
  - 4. Protect products that would be affected by adverse environmental conditions.
- B. Periodically inspect stored products to ensure that products are being stored as stipulated and that they are free from damage and deterioration.
  - 1. Any damaged or deteriorated materials must be replaced immediately to avoid delays in the project schedule.
- C. Do not remove items from storage until they are to be incorporated into the Work.
- D. The Contractor shall ensure that all protective wrappings and coverings are secure and ballasted to prevent any items from deterioration and/or subsequent dislodgment. All items on the work site that are subject to becoming windborne shall be ballasted or anchored.

### **3.2 HANDLING AND TRANSPORTATION**

- A. Handling:
  - 1. Avoid bending, scraping, or overstressing products. Protect projecting parts by blocking with wood, by providing bracing or by other approved methods.
  - 2. Protect products from soiling and moisture by wrapping or by other approved means.
  - 3. Package small parts in containers such as boxes, crates, or barrels to avoid dispersal and loss. Firmly secure an itemized list and description of contents to each container.
- B. Transportation:
  - 1. Conduct the loading, transporting, unloading, and storage of products so that they are kept clean and free from damage.

### **3.3 STORAGE**

- A. Store items in a manner that shall prevent damage to the DEN's property. Do not store

hydraulic fluids, gasoline, liquid petroleum, gases, explosives, diesel fuel, and other flammables in excavations. Petroleum products and chemicals must be stored in closed containers within secondary containment.

- B. Provide sheltered weather-tight or heated weather-tight storage as required for products subject to weather damage.
- C. Provide blocking, platforms or skids for products subject to damage by contact with the ground.
- D. All material shall be stored according to the manufacturer's recommendations. Any material that has to be stored within specified temperature or humidity ranges shall have a 24-hour continuously written recording made of the applicable condition. Should the recording show that the material was not stored within the recommended ranges the material shall be considered defective and in nonconformance. If a certification from the manufacturer's engineering design representative is provided stating that the actual variations are acceptable and will in no way harm the material or affect warranties, then the deficiency will be considered corrected.
- E. Store hazardous material separately, with all material marked with a label showing the hazard and how to treat exposure to the material. Store incompatible materials separately.
- F. Extra materials that are left over at the completion of the Work shall be removed from the Project site by the Contractor unless they are required to be delivered to DEN as per Contract Document requirements for maintenance stock.

### 3.4 LABELS

- A. Storage cabinets and sheds that will contain flammable substances and explosive substances shall be labeled "FLAMMABLE - KEEP FIRE AWAY" and "NO SMOKING" with conspicuous, bold lettering and conforming to OSHA requirements. Flammable substances shall be stored in flammable storage cabinets that conform to OSHA requirements.

## PART 4 - MEASUREMENT

### 4.1 METHOD OF MEASUREMENT

- A. No separate measurement shall be made for work under this Section.

## PART 5 - PAYMENT

### 5.1 METHOD OF PAYMENT

- A. The cost of the Work described in this Section shall be included in the applicable unit

price item, work order, or lump sum bid item.

- B. Reference Section 012910 "Schedule of Values" for additional requirements for the possible payment of stored material.

END OF SECTION 016610

## SECTION 017330 - CUTTING AND PATCHING

### PART 1 - GENERAL

- A. RELATED DOCUMENTS
- B. Drawings and general provisions of the Contract, including General and Special Conditions and other Division 01 Specification Sections, apply to this Section.
- C. Refer to Article 316, Cutting and Patching the Work in the General Contract Conditions, 2011 Edition

#### 1.2 SUMMARY

- A. Section Includes:
  - 1. Project information.
  - 2. Work covered by Contract Documents.
  - 3. Phased construction.
  - 4. Work by DEN.
  - 5. Work under separate contracts.
  - 6. Future work.
  - 7. Purchase contracts.
  - 8. DEN-furnished products.
  - 9. Contractor-furnished, DEN-installed products.
  - 10. Access to site.
  - 11. Coordination with occupants.
  - 12. Work restrictions.
  - 13. Specification and drawing conventions.
  - 14. Miscellaneous provisions.
- B. Related Requirements:
  - 1. Section 015210 "Temporary Facilities" for limitations and procedures governing temporary use of DEN's facilities.
  - 2. Section 015719 "Temporary Environmental Controls" for environmental control requirements.

#### 1.3 DEFINITIONS

- A. Cutting: Removal of existing construction to permit installation of or to perform other Work.
- B. Patching: Fitting and repair work required to restore surfaces to original conditions after installation of other Work.

## 1.4 SUBMITTALS

- A. Refer to Section 013300 "Submittal Procedures" and Section 013325 "Shop and Working Drawings, Product Data and Samples" for submittal procedures.
- B. Cutting and Patching Proposal: Submit a proposal describing procedures at least thirty (30) calendar days before the time cutting and patching will be performed, requesting approval to proceed. Obtain approval of cutting and patching proposal by DEN Project Manager before cutting and patching. Approval does not waive right to later require removal and replacement of unsatisfactory work. The proposal shall include at least the following information:
1. Identification of the Contract and the Contractor's name.
  2. Description of proposed work:
    - a. Scope of cutting, patching, alteration, or excavation.
    - b. The necessity for cutting or alteration.
    - c. Drawing showing location of the requested cutting or alteration, along with radar or x-ray report.
    - d. Trades that will execute the work.
    - e. Products proposed to be used.
    - f. Extent of refinishing to be done.
    - g. Alternatives to cutting and patching.
  3. Changes to Existing Construction: Describe anticipated results. Include changes to structural elements and operating components as well as changes in the building's appearance and other significant visual elements.
  4. Utilities: List utilities that cutting and patching procedures will disturb or affect. List utilities that will be relocated and those that will be temporarily out of service. Indicate how long service will be disrupted and proposed dates of interruption of service. Additionally, verify and locate anything in or behind the area prior to cutting.
  5. Proposed Dust Control and Noise Control Measures: Submit a statement or drawing that indicates the measures proposed for use, proposed locations, and proposed time frame for their operation. Identify options if proposed measures are later determined to be inadequate.
  6. Effect on the work and other surrounding work or on structural or weatherproof integrity of Project.
  7. Written concurrence of each contractor or entity whose work will be affected.
  8. Cost proposal, when applicable.

## 1.5 QUALITY CONTROL

- A. Operational Elements: Do not cut and patch ANY operating elements and related components in a manner that results in reducing their capacity to perform as intended or that results in increased maintenance, decreased operational life or safety unless approved by the DEN Project Manager. Operations elements may include, but are not limited to the following:

1. Primary operational systems and equipment.
  2. Air or smoke barriers.
  3. Fire protection systems.
  4. Control systems.
  5. Communication systems.
  6. Conveying systems.
  7. Electrical wiring systems.
  8. Operating systems of special construction as described in Divisions 13 and 26.
  9. HVAC systems.
- B. Miscellaneous Elements: Do not cut and patch ANY of the following elements or related components in a manner that could change their load-carrying capacity, that results in reducing their capacity to perform as intended, or those results in increased maintenance, decreased operational life or safety unless approved by the DEN Project Manager. Miscellaneous elements may include, but are not limited to the following:
1. Water, moisture, or vapor barriers.
  2. Membranes and flashings.
  3. Exterior curtain wall construction.
  4. Equipment supports.
  5. Piping, ductwork, vessels and equipment.
  6. Noise control and vibration control elements and systems.
  7. Stud walls.
  8. Roofing system
- C. Visual Elements: Do not cut and patch ANY construction in a manner that results in visual evidence of cutting and patching. Do not cut and patch construction exposed on the exterior or in occupied spaces in a manner that would reduce, in DEN's sole opinion, the building's aesthetic qualities. Remove and replace construction that has been cut and patched in a visually unsatisfactorily manner.
1. If possible, retain the original installer or fabricator to cut and patch exposed Work listed below. If it is impossible to engage the original installer or fabricator, engage another recognized, experienced, and specialized firm as approved by the DEN Project Manager. Visual elements may include, but are not limited to:
    - a. Stonework and stone masonry.
    - b. Ornamental metal.
    - c. Matched-veneer woodwork.
    - d. Preformed metal panels.
    - e. Firestopping.
    - f. Window wall systems.
    - g. Terrazzo.
    - h. Flooring.
    - i. Wall coverings and finishes.
    - j. HVAC enclosures, cabinets, or covers.
- D. Cutting and Patching Conference: Before proceeding, meet at the Project site with all parties involved in cutting and patching, including mechanical and electrical trades. Review areas of potential interference and conflict. Coordinate procedures and resolve

potential conflicts before proceeding.

## 1.6 WARRANTY

- A. Existing Warranties: Remove, replace, patch and repair materials and surfaces cut or damaged during cutting and patching operations by methods and with materials so as not to void existing warranties.
1. All effort shall be made to engage the original installer or fabricator to patch the exposed Work listed below that is damaged during selective demolition. If it is impossible to engage the original installer or fabricator, engage another recognized, experienced and specialized firm as approved by the DEN Project Manager:
    - a. Processed concrete finishes.
    - b. Stonework and stone masonry.
    - c. Ornamental metal.
    - d. Matched-veneer woodwork.
    - e. Preformed metal panels.
    - f. Firestopping.
    - g. Window wall systems.
    - h. Terrazzo.
    - i. Flooring.
    - j. Wall coverings and finishes.
    - k. HVAC enclosures, cabinets, or covers.

## 1.7 MATERIALS

- A. General: All patching material shall be of the type specified for the material being patched. Comply with requirements specified in other specifications Sections.
- B. Existing Materials: Use materials identical to existing materials. For exposed surfaces, use materials that visually and texturally match existing adjacent surfaces to the fullest extent possible.
1. If identical materials are unavailable or cannot be used, use materials that, when installed, will match the visual and functional performance of existing materials as approved by the DEN Project Manager.

## **PART 2 - PRODUCTS (NOT USED)**

## **PART 3 - EXECUTION**

### 3.1 EXAMINATION

- A. Examine surfaces to be cut and patched and conditions under which cutting and

patching are to be performed.

1. Compatibility: Before patching, verify compatibility with and suitability of substrates, including compatibility with existing finishes or primers. Provide additional substrates or materials if required to achieve desired final results of patching work.
2. Immediately notify the DEN Project Manager, in writing, of unsuitable, unsafe, or unsatisfactory conditions.
3. Proceed with installation only after unsafe or unsatisfactory conditions have been corrected.
4. Proceed with patching only after construction operations requiring cutting are complete and inspected by the DEN Project Manager.

### 3.2 PREPARATION

- A. Temporary Support: Provide temporary support of Work to be cut to ensure structural value or integrity.
- B. Protection: Protect existing construction during cutting and patching to prevent damage. Provide protection from adverse weather conditions for portions of the Project that might be exposed during cutting and patching operations.
- C. Adjoining Areas: Avoid interference with use of adjoining areas or interruption of free passage to adjoining areas.
- D. Existing Services: Where existing services are required to be removed, relocated, or abandoned, bypass such services before cutting to avoid or minimize interruption of services to occupied areas. Do not interrupt services in without approval from the appropriate authority. Refer to the appropriate Shutdown specification/procedures for applicable services.

### 3.3 POLLUTION CONTROLS

- A. Dust Control: Use water mist, temporary enclosures, and other suitable methods to limit the spread of dust and dirt. Comply with governing environmental protection regulations. Reference Section 015719 "Temporary Environmental Controls" for requirements.
  1. Do not use water when it may damage existing construction or create hazardous or objectionable conditions such as ice, flooding, and pollution.
  2. Wet mop floors to eliminate trackable dirt and wipe down walls and doors of demolition enclosures. Vacuum carpeted areas. Professionally clean carpeted areas if required.
  3. For outdoor concrete saw cutting operations, slurry waste must be vacuumed up immediately to prevent migration off-site to pervious surfaces, surface waters or drains.
- B. Disposal: Remove and transport debris in a manner that will prevent spillage on



adjacent surfaces and areas.

1. Concrete slurry waste must be disposed of properly in accordance with applicable airport, local and state rules and regulations.
- C. Cleaning: Clean adjacent structures and improvements of dust, dirt, and debris caused by selective demolition operations. Return adjacent areas to the condition existing before selective demolition operations began.

### 3.4 PERFORMANCE

- A. General: Employ skilled workers to perform cutting and patching. Execute cutting and demolition by methods that will prevent damage to other work and will provide a proper surface to receive patching.
1. Cut existing construction to provide for installation of other components or performance of other construction, and subsequently patch as required to restore surfaces to their original condition.
  2. Execute fitting and adjustment of products to provide a finished installation to comply with specified products, functions, tolerance, and finishes.
  3. Restore work that has been cut or removed; install new products to provide complete work in accordance with requirements of the Contract Documents.
  4. Fit work airtight and fire safe to pipes, sleeves, ducts, conduit, and other penetrations through surfaces as required by the Contract Documents.
- B. Cutting: Cut existing construction by sawing, drilling, breaking, chipping, grinding, and other similar operations, including excavation, using methods least likely to damage elements retained to adjoining construction. If possible, review proposed procedures with original installer and comply with original installer's written recommendations.
1. In general, use ground fault hand or small power tools designed (to short if metal is hit) for sawing and grinding, not hammering and chopping. Cut holes and slots as small as possible, neatly to the size required, and with minimum disturbance of adjacent surfaces. Temporarily cover openings when not in use.
  2. Existing Finished Surfaces: Cut or drill from the exposed or finished side into concealed surfaces.
  3. Concrete: Use a cutting machine such as an abrasive saw or a diamond-core drill.
  4. Proceed with patching after construction operations requiring cutting are complete.
- C. Patching: Patch construction by filling, repairing, refinishing, closing up, and similar operations following performance of other Work. Patch with durable seams that are as invisible as possible. Provide materials and comply with installation requirements specified in other specification Sections.
1. Inspection: Where feasible, test and inspect patched areas after completion to demonstrate integrity of installation.
  2. Exposed Finishes: Restore exposed finishes of patched areas and extend finish

restoration into retained adjoining construction in a manner that will eliminate evidence of patching and refinishing. For continuous surfaces, refinish entire unit to the nearest break line. For an assembly, refinish entire unit.

3. Floors and Walls: Where walls or partitions that are removed extend one finished area into another, patch and repair floor and wall surfaces in the new space. Provide an even surface of uniform finish, color, texture, and appearance. Remove existing floor and wall coverings and replace with new materials, if necessary, to achieve uniform color and appearance.

- a. Where patching occurs on a painted surface, apply primer and intermediate paint coats over the patch and apply the final coat over the entire unbroken surface containing the patch. Provide additional coats until the patch blends with adjacent surfaces.

4. Ceilings: Patch, repair or re-hang existing ceilings as necessary to provide an even-plane surface of uniform appearance.

- D. Fire Rated Construction: Where rated elements are cut, reconstruct to approved designs to provide original fire rating.

### 3.5 CORE DRILLING

- A. The Contractor shall execute a minimum of x-rays or ground penetrating radar (GPR) at each location planned for core drilling prior to submittal to the DEN Project Manager and to utility representatives for approval for core drilling. The request for approval shall be submitted a minimum seven (7) days before Core Drilling. The request for approval shall indicate on the x-ray or radar information regarding alternate locations or core drilling to avoid structural members and any embedded conduit. Embedded conduit may be metallic or plastic. The x-ray or radar system shall be capable of detecting both types of conduit.
- B. Core drilled "cores" and the core-drilled opening shall be inspected by DEN Project Manager Representatives prior to installation of any systems in new openings.

## PART 4 - MEASUREMENT

### 4.1 METHOD OF MEASUREMENT

- A. No separate measurement shall be made for work under this Section.

## PART 5 - PAYMENT

### 5.1 METHOD OF PAYMENT

- A. No separate payment will be made for work under this Section.

END OF SECTION 017330

## SECTION 017419 - CONSTRUCTION WASTE MANAGEMENT AND DISPOSAL

### PART 1 - GENERAL

#### 1.1 RELATED DOCUMENTS

- A. Drawings and general provisions of the Contract, including General and Special Conditions and other Division 01 Specification Sections, apply to this Section.

#### 1.2 SUMMARY

- A. This section describes the requirements for the disposal, recovery, reuse or recycling of non-hazardous and non-asbestos containing construction and demolition waste for both LEED and non-LEED projects. Note that LEED projects may have more specific requirements than identified in this section.
- B. Waste materials shall be managed in accordance with all local, state, and federal regulations.
- C. Related Requirements:
  - 1. Section 013300 "Submittal Procedures" for submittal procedures.
  - 2. Section 013325 "Shop and Working Drawings, Product Data and Samples" for submittal procedures.
  - 3. Section 015719 "Temporary Environmental Controls" for environmental control procedures.

#### 1.3 DEFINITIONS

- A. Solid Waste: means any garbage, refuse, sludge from a waste treatment plant, water supply treatment plant, air pollution control facility, or other discarded material; including solid, liquid, semisolid, or contained gaseous material resulting from industrial operations, commercial operations or community activities. Solid waste does not include any solid or dissolved materials in domestic sewage, or agricultural wastes, or solid or dissolved materials in irrigation return flows, or industrial discharges which are point sources subject to permits under the provisions of the "Colorado Water Quality Control Act", Title 25, Article 8, CRS or materials handled at facilities licensed pursuant to the provisions on "Radiation Control Act" in Title 25, Article 11, CRS. Solid waste does not include:
  - 1. Materials handled at facilities licensed pursuant to the provisions on radiation control in Article 11 of Title 25, C.R.S.
  - 2. Excluded scrap metal that is being recycled.
  - 3. Shredded circuit boards that are being recycled.
- B. Salvaged Materials: Defined as materials that exist on the site that can be reused,

either on site or by another entity

- C. Recyclable Materials: Defined as materials that exist on site or are generated during the construction process that can be recycled and/or remanufactured into another material. Recyclable waste includes, but is not limited to, the following:
1. Concrete.
  2. Asphalt
  3. Ferrous and non-ferrous metals.
  4. Untreated wood, engineered wood.
  5. Gypsum wallboard.
  6. Corrugated cardboard, paper goods.
  7. Plastic.
  8. Glass, insulation.
  9. Carpet.
  10. Paints, fabric.
  11. Rubber.
  12. Stone and brick.
- D. Hazardous Waste: Per 6 CCR 1007-3, those substances and materials defined or classified as such by the Hazardous Waste Commission pursuant to 25-15-302, C.R.S., as amended. Also, see hazardous waste definition per 40 CFR 261.3.
- E. Asbestos Containing Materials: Per 5 CCR 1001-10: Regulation No. 8, The Control of Hazardous Air Pollutants, Part B The Control of Asbestos- material containing more than 1% asbestos

#### 1.4 SUBMITTALS

- A. The Contractor shall submit a list of materials and products used with Safety Data Sheets (SDS). Examples include chemicals, solvents, fuels, building materials, etc.
1. A hardcopy or electronic link to the SDS for all materials and products used, if applicable.
  2. Identify storage methods for materials, including measures to segregate incompatible materials.
- B. The Contractor shall submit a Waste Management Plan to the DEN Project Manager and DEN Environmental Services. Minimum Waste Management Plan requirements include the following:
1. A list of all waste streams generated by the project
    - a. For each waste stream listed, the Contractor shall identify the handling/transportation method, the disposal method, and the disposal facility utilized.
    - b. If the Contractor anticipates generation of hazardous waste, the Contractor shall provide its USEPA (generator) identification number.

2. Pollution Prevention Measures
    - a. Describe best practices that will reduce waste. For example, waste reduction measures, requiring vendors to deliver materials in reusable packaging, etc.
  3. Waste Management Plan Training.
  4. Storage of materials.
  5. Spill response.
- C. Approval of Contractor's Waste Management Plan does not relieve the contractor of responsibility for compliance with applicable environmental regulations.
1. The contractor shall maintain a record of the amounts of construction and demolition waste generated, recycled, reused, salvaged, or disposed of, in pounds for review.
  2. Hauling manifest records shall be maintained and available for review. Manifest forms are available from the DEN Project Manager

## **PART 2 - PRODUCTS**

- 2.1 A list of all materials and products used. Examples include chemicals, solvents, solvents, fuels, curing compounds, etc.
- A. A hardcopy or electronic link to SDSs for all materials and products used.
  - B. Identify storage methods, including measures to segregate incompatible materials.
  - C. Refer to the Waste Management Plan

## **PART 3 - EXECUTION**

- A. The Contractor shall not wash down equipment in such a manner as to flush grease, oils, detergents, and other contaminants onto the project site or onto airport property unless the waste is properly contained, treated, and disposed of.
- B. DEN maintains two dry concrete and asphalt recycling yards used for the accumulation and crushing of asphalt and concrete. The South Yard is located on 71st Ave just east of Jackson Gap Street. The North Yard is located on the south side of 110th, west of Queensburg Street.
- C. Concrete washwater cannot be discharged to surface waters or to storm sewer systems. Colorado Discharge Permit System (CDPS) coverage conditionally authorizes discharges to the ground of concrete wash water from washing of tools and concrete mixer chutes when appropriate best management practices (BMPs) are implemented.
  1. A bermed containment area that allows discharge water to infiltrate or evaporate;

- a. Alternatives to bermed containment areas include portable concrete washout bins, and industrial washout containment systems where the accumulated waste is removed from the site and disposed of properly.
  2. Use of the washout site should be temporary (less than one year);
  3. The washout site should not be located in an area where shallow groundwater may be present, such as near natural drainages, springs, or wetlands
  4. Upon termination of the washout site, accumulated solid waste, which includes concrete waste and contaminated soils, must be removed from the site and disposed of properly.
- D. Rejected loads and/or other wet concrete or asphalt materials are PROHIBITED TO BE PLACED ANYWHERE on DEN property. These materials must be returned to the facility of origination or other permitted facility for proper disposal.
- E. Concrete saw cutting slurry must be properly contained and disposed of.
- F. Unknown or questionable materials encountered during construction activities, must immediately be reported to the DEN Communications Center at (303) 342-4200 and the DEN Project Manager.

#### **PART 4 - MEASUREMENT**

##### 4.1 METHOD OF MEASUREMENT

- A. No separate measurement shall be made for work under this Section.

#### **PART 5 - PAYMENT**

##### 5.1 METHOD OF PAYMENT

- A. No separate payment will be made for work under this Section.

END OF SECTION 017419

## SECTION 017420 - CLEANING

### PART 1 - GENERAL

#### 1.1 RELATED DOCUMENTS

- A. Drawings and general provisions of the Contract, including General and Special Conditions and other Division 01 Specification Sections, apply to this Section.

#### 1.2 SUMMARY

- A. The Work specified in this section consists of maintaining a clean, orderly, hazard free work site during construction, and final cleaning for the City's Final Acceptance. Failure to maintain the work site will be grounds for withholding monthly payments until corrected to the satisfaction of the DEN Project Manager.
- B. Refer to Article 325, Cleanup During Construction in the General Contract Conditions, 2011 Edition

#### 1.3 JOB CONDITIONS

##### A. Safety Requirements

1. Maintain the work site in a neat, orderly, and hazard-free manner in conformance with all federal, state, and local rules, codes, regulations, and orders, including all OSHA requirements, until Final Acceptance of the Work. Keep catwalks, underground structures, work site walks, sidewalks, roadways, and streets, along with public and private walkways adjacent to the work site, free from hazards caused by construction activities. Inspect those facilities regularly for hazardous conditions caused by construction activities.

##### B. Hazards Control:

1. Store waste materials in properly labeled waste containers. This includes solid wastes, hazardous wastes, universal wastes, etc.
2. Store volatile wastes in covered metal containers and remove those wastes from work site daily.
3. Do not accumulate wastes that create hazardous conditions.
4. If volatile and noxious substances are being used in spaces that are not naturally ventilated adequately, provide artificial ventilation.
5. Hazard controls shall conform to the applicable federal, state, and local rules and regulations.
6. Provide appropriate waste receptacles in all areas in which employees are working. Waste receptacles shall be kept covered at all times. All materials on site shall be anchored and covered to prevent any objects from becoming wind-borne.



C. Access:

1. Maintain the work site to permit access by other City contractors as required and to allow access by emergency personnel.

1.4 SUBMITTALS

A. Washing Plan: The Contractor shall prepare a plan describing the specific procedures and materials to be utilized for any equipment, vehicle, etc., washing activities. The plan must be submitted to the DEN Project Manager and approved by the DEN Project Manager and Environmental Services.

1. Outdoor washing at DEN is not allowed unless the materials will be collected or managed in a manner to ensure that they will not enter the municipally owned separate storm sewer system (MS4). The materials can only be disposed at a location pre-approved by DEN Environmental Services (refer to DEN SWMP). Failure to comply with this requirement would result in the discharge of non-stormwater.
  - a. Outdoor wash materials that contain soaps or other cleaning chemicals must be collected and disposed of off site
2. Indoor washing must be conducted in accordance with the Best Management Practices (BMPs) detailed in the DEN SWMP. Refer to Section 015719 "Environmental Controls". In addition, all indoor washing must be conducted in a manner that ensures that there are no prohibited discharges to the sanitary sewer system.
  - a. All wash-water that will be disposed of into the sanitary sewer must comply with City and County Denver rules and regulations pertaining to prohibited discharges.

**PART 2 - PRODUCTS**

2.1 CLEANING MATERIALS

- A. Utilize the type of cleaning materials recommended by the manufacturer for the surfaces to be cleaned.
- B. Maintain current Safety Data Sheets (SDS) on site for all chemicals. DEN Environmental Services must approve the chemicals used prior to discharge to the sanitary sewer system.
- C. Ensure proper disposal of all wastes generated from the use of these materials. The Contractor must ensure compliance with all environmental regulations. No wastes can be disposed of on DEN property.

## **PART 3 - EXECUTION**

### **3.1 INTERIM CLEANING**

- A. Clean the work site every shift/workday for the duration of the construction Contract. Maintain structures, grounds, storage areas and other areas of work site, including public and private properties immediately adjacent to work site, free from accumulations of waste materials caused by construction operations. Place waste materials in covered metal containers. All hard concrete, steel, wood, and finished walking surfaces shall be swept clean daily.
- B. Remove or secure loose material on open decks and on other exposed surfaces at the end of each workday or more often in a manner that will maintain the work site hazard free. Secure material in a manner that will prevent dislodgment by wind and other forces.
- C. Sprinkle waste materials with water or acceptable chemical palliative to prevent blowing of dust.
- D. Promptly empty waste containers when they become full and legally dispose of the contents at dumping areas off the City's property.
- E. Control the handling of waste materials. Do not permit materials to be dropped or thrown from structures.
- F. Immediately remove spillage of construction related materials from haul routes, work site, private property, public rights of way, or on the Denver International Airport site.
- G. Clean only when dust and other contaminants will not precipitate upon newly painted surfaces.
- H. Cleaning shall be done in accordance with manufacturer's recommendation.
- I. Cleaning shall be done in a manner and using such materials as to not damage the Work.
- J. Clean areas prior to painting or applying adhesive.
- K. Clean all heating and cooling systems prior to operations. If the Contractor is allowed to use the heating and cooling system, it shall be cleaned prior to testing.
- L. Clean all areas that will be concealed prior to concealment.
- M. Dispose of all fluids according to the approved Washing Plan.

### **3.2 FINAL CLEANING**

- A. Refer to Article, Clean-up Upon Completion in the General Contract Conditions, 2011 Edition. Additionally, the Contractor, shall at a minimum, complete the following:

1. Inspect interior and exterior surfaces, including concealed spaces, in preparation for completion and acceptance.
2. Remove dirt, dust, litter, corrosion, solvents, discursive paint, stains, and extraneous markings.
3. Remove surplus materials, except those materials intended for maintenance.
4. Remove all tools, appliances, equipment, and temporary facilities used in the construction.
5. Remove detachable labels and tags. File them with the manufacturer's specifications for that specific material for the City's records.
6. Repair damaged materials to the specified finish or remove and replace.
7. After all trades have completed their work and just before Final Acceptance, all catch basins, manholes, drains, strainers and filters shall be cleaned; roadway, driveways, floors, steps and walks shall be swept. Interior building areas shall be vacuum cleaned and mopped.
8. Final cleanup applies to all areas, whether previously occupied and operational or not.
9. Dispose of all fluids according to the approved Washing Plan.

#### **PART 4 - MEASUREMENT**

##### **4.1 METHOD OF MEASUREMENT**

- A. No separate measurement shall be made for work under this Section.

#### **PART 5 - PAYMENT**

##### **5.1 METHOD OF PAYMENT**

- A. No separate payment will be made for work under this Section.

**END OF SECTION 017420**

## **SECTION 017515 - SYSTEM STARTUP, TESTING AND TRAINING**

### **PART 1 - GENERAL**

#### 1.1 RELATED DOCUMENTS

- A. Drawings and general provisions of the Contract, including General and Special Conditions and other Division 01 Specification Sections, apply to this Section.

#### 1.2 SUMMARY

- A. Provide complete startup, testing, and operator training services to ensure operability of all systems supplied.
- B. Coordinate all start-up and testing with DEN Commissioning Authority or DEN Asset Management through the DEN Project Manager.

#### 1.3 SUBMITTALS

- A. Refer to Section 013300 "Submittal Procedures" and 013325 "Shop and Working Drawings, Product Data and Samples" for submittal procedures. Submit the following:
  - 1. Test procedures.
  - 2. Test reports.
  - 3. Training outline.
- B. Submit Qualification Data: For [**instructor**].
- C. Attendance Record: For each training module submit the following:
  - 1. Module title
  - 2. Module description
  - 3. Length of instruction time
  - 4. Participant names
- D. Evaluations: For each participant and for each training module, submit results and documentation of performance-based test.

#### 1.4 QUALITY ASSURANCE

- A. Facilitator Qualifications: A firm or individual experienced in training or educating personnel in a training program similar in content and extent to that indicated for this Project, and whose work has resulted in training or education with a record of successful learning performance.

- B. Instructor Qualifications: A factory-authorized service representative, experienced in operation and maintenance procedures and training.
- C. Videographer Qualifications: A professional videographer who is experienced photographing demonstration and training events similar to those required. Recordings shall be high-resolution **4k** with a minimum framerate of 60Hz
- D. Preinstruction Conference: Conduct conference at Project site to comply with requirements in Section 014510 "Contractor Quality Control". Review methods and procedures related to demonstration and training including, but not limited to, the following:
  - 1. Inspect and discuss locations and other facilities required for instruction.
  - 2. Review and finalize instruction schedule and verify availability of educational materials, instructor's personnel, audiovisual equipment, and facilities needed to avoid delays. Ensure that students are notified at least 14 [insert other] days prior to the start of instruction.
  - 3. Review required content of instruction.
  - 4. For instruction that must occur outside, review weather and forecasted weather conditions and procedures to follow if conditions are unfavorable.

## 1.5 COORDINATION

- A. Coordinate instruction schedule with DEN's operations. Adjust schedule as required to minimize disrupting DEN's operations and to ensure availability of DEN's personnel. As required, include multiple classed to accommodate various shifts
- B. Coordinate instructors, including providing notification of dates, times, length of instruction time, and course content.
- C. Coordinate content of training modules with content of approved emergency, operation, and maintenance manuals. Do not submit instruction program until operation and maintenance data has been reviewed and approved by DEN Project Manager.

## PART 2 - PRODUCTS (NOT USED)

## PART 3 - EXECUTION

### 3.1 FIELD TESTS AND ADJUSTMENTS

- A. All electrical and mechanical equipment including the interfaces with control systems and the communication system, and all alarm and operating modes for each piece of equipment, shall be tested by the Contractor to the satisfaction of the DEN Project Manager before any facility is put into operation. Tests shall be as specified herein and shall be made to determine whether the equipment has been properly assembled, aligned and connected. Any changes, adjustments, or replacements required to make

the equipment operate as specified shall be carried out by the Contractor as part of the Work.

1. At least thirty (30) days before the time allowed in the construction schedule for commencing startup and testing procedures, the Contractor shall submit to the DEN Project Manager six (6) copies of the detailed procedures the Contractor proposes for testing and startup of all electrical and mechanical equipment. These procedures are submitted for review and acceptance by DEN.
  2. The Contractor's startup and testing procedures shall include detailed descriptions of all pre-operational hardware, electrical, mechanical and instrumentation used for testing work.
    - a. Each control device, item of electrical, mechanical and instrumentation equipment, and all control circuits shall be considered in the testing procedures which shall be designed in a logical sequence to ensure that all equipment has been properly serviced, aligned, connected, wired, calibrated and adjusted prior to operation.
    - b. Motors shall be tested in accordance with ANSI/IEEE Publication 112. The Contractor is advised that failure to observe these precautions may place the acceptability of the subject equipment in question, and the Contractor may either be required to demonstrate that the equipment has not been damaged, or replace it as determined by the DEN Project Manager.
  3. Testing procedures shall be designed to duplicate as nearly as possible all conditions of operations and shall be carefully selected to ensure that the equipment is not damaged. All filters shall be in place during startup and testing.
    - a. Once the DEN Project Manager has accepted the testing procedures, the Contractor shall provide checkout, alignment, adjustment and calibration signoff forms for each item of equipment and each system that will be used.
    - b. The Contractor and the DEN Project Manager shall use the signoff forms in the field jointly to ensure that each item of electrical, mechanical and instrumentation equipment and each system has been properly installed and tested. The Contractor shall cooperate with project-wide systems contractors where startup and testing is to be conducted concurrently.
  4. Any special equipment needed to test equipment shall be provided by the Contractor to the City at no cost for a period of thirty (30) days during startup.
- B. Before starting up the equipment, the Contractor shall properly service it and other items, which normally require service in accordance with the maintenance instructions. The Contractor shall be responsible for lubrication and maintenance of equipment and replacement filters throughout the entire equipment "break-in" period described by the manufacturer.
1. The Contractor shall be responsible for the startup, adjustment, preliminary maintenance, and checkout of all equipment and instrumentation. All systems shall be carefully checked for conformance with the design criteria.
  2. If any equipment or system does not operate as specified in the Contract, the Contractor shall immediately replace or repair components until it operates

properly.

3. The Contractor shall submit a test report to the DEN Project Manager within thirty (30) days after completion of the system startup period.

### 3.2 SYSTEMS STARTUP AND TESTING

- A. The Contractor shall be responsible for a 30-day startup period during which time all hardware, electrical and mechanical equipment, communications, alarm systems, and associated devices shall be energized and operated under local and automatic controls. The Contractor shall be present during the startup period with adequate labor and support personnel to adjust equipment and troubleshoot system failures that might arise.
- B. When a piece of electrical or mechanical equipment is found to be in conflict with specific criteria, an experienced representative of the manufacturer shall adjust the item.
- C. If adjustments fail to correct the operation of a piece of equipment or fixture, the Contractor shall remove the equipment or fixture from the Project site and replace it with a workable replacement that meets the specification requirements.
- D. The 30-day startup period shall commence thirty (30) days prior to the Contract completion date and shall be completed prior to final payment. If, during the startup, any system fails to operate in accordance with Contract requirements, the failure shall be corrected and the startup period shall begin again.
  1. At the end of the startup period, all filters shall be replaced with new ones.
  2. The City may provide, at its option, a Commissioning Representative to observe or participate in the startup and testing of any system. The Contractor shall coordinate with the Commissioning Representative relating to scheduling, reporting, forms, methods, and procedures of the startup and testing.

### 3.3 FINAL INSTRUCTIONS AND OPERATION TRAINING

- A. After startup and testing is completed, the Contractor shall demonstrate to the City's personnel the proper manner of operating the equipment, programming messages, making adjustments, responding to alarms and emergency signals, and maintaining the system.
- B. The Contractor shall provide on-the-job training by a suitably qualified instructor to designated personnel and shall instruct them in the operation and maintenance of the systems. In the event qualified instructors on the Contractor's staff are not available, the Contractor shall arrange with the equipment manufacturer for such instruction at no additional cost to the City.
- C. The Contractor shall provide a minimum of eight (8) hours of operator training to the Airport per shift. Classes shall accommodate up to five (5) people at a time with up to two (2) separate courses (one for each shift).

- D. The Contractor shall provide a syllabus to the DEN Project Manager at least seven (7) calendar days prior to the start of each course that outlines topics to be covered, the proposed time allotted to each topic, and the target audience of the training session (technical, casual operator, overview, etc.). The Contractor shall not commence any training courses until the syllabus has been reviewed and approved by the DEN Project Manager.
- E. The Contractor shall video record all training sessions and provide to the DEN Project Manager. The Contractor shall provide video recordings in format as required in Section 017900 "Demonstration and Training".
- F. The Contractor shall provide an annotated syllabus to the DEN Project Manager that indicates topics contained on each tape.
- G. The contractor shall provide instruction for obtaining live help for questions relating operation and troubleshooting

#### **PART 4 - MEASUREMENT**

##### 4.1 METHOD OF MEASUREMENT

- A. No separate measurement shall be made for work under this Section.

#### **PART 5 - PAYMENT**

##### 5.1 METHOD OF PAYMENT

- A. No separate payment will be made for work under this Section.
- B. No contractual item requiring startup or testing will be paid until the conditions of this Section are completely satisfied.

END OF SECTION 017515





## **SECTION 017720 - CONTRACT CLOSEOUT**

### **PART 1 - GENERAL**

#### 1.1 RELATED DOCUMENTS

- A. Drawings and general provisions of the Contract, including General and Special Conditions and other Division 01 Special Sections, apply to this Section.

#### 1.2 SUMMARY

- A. Work specified in this Section includes procedures required prior to Final Acceptance of the Work in addition to those specified in Title 20 – Final Completion and Acceptance of The Work in the General Contract Conditions, 2011 Edition, and Technical Specification Section 017840 "Contract Record Documents".
- B. This Section also includes procedures and penalties to ensure prompt completion of the Project Closeout.
- C. Related Sections:
  - 1. Title 20 of the General Contract Conditions, 2011 Edition..
  - 2. Section 017840 "Contract Record Documents" for required record documents.
  - 3. Form CM-75, Closeout Checklist
- D. SUBMITTALS
  - 1. Submit written Certification to the DEN Project Manager that, in the opinion of the Contractor, the Work is complete.
  - 2. Submit final survey within 60 days after issuance of Substantial Completion.
  - 3. Submit a Final Statement of Accounting to the DEN Project Manager.

### **PART 2 - PRODUCTS (NOT USED)**

### **PART 3 - EXECUTION**

#### 3.1 PREPARATION FOR FINAL INSPECTION

- A. Before requesting inspection for Final Acceptance of the Work by the City, the Contractor shall inspect, clean, and repair the Work as required.
- B. The Contractor shall ensure that all items on the Closeout Checklist have been addressed and accepted by the DEN Project Manager.

### 3.2 FINAL INSPECTION

- A. The Contractor shall submit written certification to the DEN Project Manager when, in the opinion of the Contractor, the Work is complete. Such communication shall certify that:
1. The Work has been inspected by the Contractor for conformance with the Contract Documents.
  2. The Work has been completed in conformance with the Contract Documents, including all punchlist items.
  3. The Work is ready for final inspection by the City.
  4. All as-built documents have been submitted and accepted.
  5. All damaged or destroyed real, personal, public, or private property impacted by the Work has been repaired or replaced.
  6. All Warranties and Bonds have been completed, executed, submitted, and accepted.
  7. All personnel badges and vehicle permits have been returned to DEN Airport Security.
- B. The DEN Project Manager will inspect the Work in accordance with the Section 2002.1 of the City and County of Denver's Department of Aviation's General Contract Conditions.
- C. If the DEN Project Manager finds incomplete or defective Work:
1. The DEN Project Manager may, at the DEN Project Manager's sole discretion, either terminate the inspection, or prepare a punchlist and notify the Contractor in writing, listing the incomplete or defective Work.
  2. The Contractor shall take immediate steps to remedy all identified deficiencies and resubmit a written certification to the DEN Project Manager that Work is complete.
  3. The DEN Project Manager will then re-inspect the Work.

### 3.3 REINSPECTION FEES

- A. Should the DEN Project Manager be required to perform re-inspections of the Work due to the Contractor prematurely claiming the status of the Work to be complete:
1. The Contractor shall compensate the City for such additional services at the rate of \$125.00 per man-hour, with a minimum charge of \$250.00.
  2. The City shall deduct the amount of such compensation from the final payment to the Contractor.

### 3.4 FINAL SURVEY FEES

- A. The Contractor shall complete and submit the final survey within 60 days after issuance of Substantial Completion. If the Contractor fails to complete and submit the final survey within this time frame it is understood that DEN will arrange for a qualified

surveying company to complete this work at the Contractor's expense. All costs associated with DEN arranging for and completing the final survey will be deducted from the final payment including compensation due the City for the DEN Project Manager's time to manage this work.

1. The DEN Project Manager's rate of compensation shall be set at \$150.00 per man-hour.
2. Survey submittals needing to be revised may extend the 60-day time frame at the DEN Project Manager's discretion.
3. Costs, including the DEN Project Manager's, for the review of the resubmitted survey shall be deducted from the final payment.

### 3.5 LATE CLOSEOUT FEES

- A. Within 100 days after issuance of substantial completion, all documentation required by this Contract to achieve Project Closeout shall be submitted. Failure to submit all required documentation shall result in fees to compensate the City for project management work while the project remains open.
  1. Fees at the rate of \$450 per day.
  2. The resubmittal of required documents may extend the 100-day time frame at the DEN Project Manager's discretion.

### 3.6 FINAL ADJUSTMENT OF ACCOUNTS

- A. Submit a Final Statement of Accounting to the DEN Project Manager.
- B. The Final Statement of Accounting shall reflect all adjustments to the Contract amount and shall include the following:
  1. The original Contract Value.
  2. Additions and deductions resulting from the following:
    - a. Approved Change Orders.
    - b. Allowances.
    - c. Final quantities for unit price items, including required backup for the quantities.
    - d. Deductions for corrected work.
    - e. Penalties.
    - f. Deductions for liquidated damages.
    - g. Deductions for re-inspection payments.
    - h. Other adjustments.
  3. Total Contract Value, as adjusted.
  4. Previous payments.
  5. Sum remaining due.
- C. If required, the DEN Project Manager will prepare a final Change Order, reflecting the approved adjustments to the Contract Value that were not included in previously

issued Change Orders.

### 3.7 FINAL APPLICATION FOR PAYMENT

- A. The Contractor shall submit the final application for payment in accordance with the procedures and requirements detailed in Article 2003, Final Settlement in the General Contract Conditions, 2011 Edition.

## **PART 4 - MEASUREMENT**

### 4.1 METHOD OF MEASUREMENT

- A. No separate measurement shall be made for work under this Section.

## **PART 5 - PAYMENT**

### 5.1 METHOD OF PAYMENT

- A. No separate payment will be made for work under this Section.

END OF SECTION 017720

## SECTION 017825 - OPERATION AND MAINTENANCE DATA

### PART 1 - GENERAL

#### 1.1 RELATED DOCUMENTS

- A. Drawings and general provisions of the Contract, including General and Special Conditions and other Division 01 Specification Sections, apply to this Section.

#### 1.2 SUMMARY

- A. The Work specified in this Section consists of preparing and submitting operation and maintenance data for mechanical, electrical, and other specified equipment/products.
- B. Coordinate all the requirements of the required data with DEN Asset Management.

#### 1.3 SUBMITTALS

- A. Refer to Section 013300 "Submittal Procedures" and Section 013325 "Shop and Working Drawings, Product Data and Samples" for submittal procedures.
- B. All submittals must be provided in electronic data as indicated by the DEN Building Information Modeling (BIM) Design Standards Manual (DSM) and as required by the DEN BIM and DEN Asset Management groups.
- C. Submit one (1) electronic copy and three (3) bound hard copies of the proposed Operation and Maintenance Data Manual not less than [30] [90] days prior to [system startup] [acceptance tests and final inspection].
  - 1. The submitted copies shall provide the Information following the MasterFormat standard. Equipment/Data shall be organized using Section formatting within the 50 MasterFormat Divisions.
- D. Submit one (1) electronic copy and three (3) bound hard copies of Operation and Maintenance Data Manual within ten days after [system startup] [commissioning] is complete. These copies shall incorporate any comments made on the previous submittals, along with final readings on all settings and gauges taken while the system is in fully satisfactory operation.

#### 1.4 CONTINUOUS UPDATING PROGRAM

- A. Furnish to DEN AIM Asset Management one (1) electronic copy of the Contractor's letter indicating that suppliers have been notified to provide updated operation and maintenance data, service bulletins, and other information pertinent to the equipment, as it becomes available.

## **PART 2 - PRODUCTS**

- A. The following products are the requirements of hard copies:
1. Paper size: 8-½ inches x 11 inches.
  2. Paper: White bond, at least 20-pound weight.
  3. Text: Typewritten.
  4. Printed data: Manufacturer's catalog cuts, brochures, operation, and maintenance data. Clear reproductions thereof will be acceptable. If this data is in color, all final manuals must contain color data.
  5. Drawings: 8½ inches x 11 inches, bound with the text. Larger drawings are acceptable provided they are folded to fit into a pocket inside the rear cover of the manual. Reinforce edges of large drawings.
  6. Prints of drawings: Black ink on white paper, sharp in detail and suitable for making reproductions.
  7. Flysheets: Separate each portion of the manual with colored, neatly prepared flysheets briefly describing the contents of the ensuing portion.
  8. Covers: Provide 40 to 50 mil, clear plastic, front and plain back covers for each manual. The front covers shall contain the information required in paragraph 3.2 below.
  9. Bindings: Conceal the binding mechanism inside the manual. Lockable 3-ring binders shall be provided.
  10. Training Videos: Provide in digital electronic format as per current DEN requirements.
    - a. Refer to Section 017900 - Demonstration and Training for video requirements.

## **PART 3 - EXECUTION**

### **3.1 GENERAL**

- A. Assemble each operation and maintenance manual using the manufacturer's latest standard commercial data, and include all additional information that is unique to the Project.

### **3.2 COVER**

- A. Include the following information on the front cover and on the inside cover sheet:
1. Operation and maintenance instructions.
  2. Title of structure or facility.
  3. Title and number of Contract.
  4. Contractor's name and address.
  5. General subject of the manual.

### 3.3 CONTENTS OF THE MANUAL

1. Table of Contents, which references, at a minimum, three heading levels.
2. Index of Equipment/Data with entries for equipment type and MasterFormat Division and Section.
3. A Master Index that contains index entries for all submitted Operation and Maintenance Data Manuals.
  - a. Equipment/Data shall be indexed by equipment type and MasterFormat Division and Section.
4. Name, address, and telephone numbers of Contractor, suppliers and installers along with the manufacturer's order number and description of the order.
5. Name, address, and telephone numbers of manufacturer's nearest service representatives.
6. Name, address, and telephone number of nearest parts vendor and service agency.
7. Copy of guaranties and warranties issued to, and executed in the name of, the City.
8. Anticipated date the City assumes responsibility for maintenance.
9. Description of system and component parts including theory of operation.
10. Pre operation check or inspection list.
11. Procedures for starting, operating, and stopping equipment.
12. Post operation check or shutdown list.
13. Inspection and adjustment procedures.
14. Troubleshooting and fault isolation procedures for on-site level of repair.
15. Emergency operating instructions.
16. Accepted test data.
17. Maintenance schedules and procedures.
18. Test procedures to verify the adequacy of repairs.
19. One (1) copy of each wiring diagram.
20. One (1) copy of each piping diagram.
21. Location where all measurements are to be made.
22. One (1) copy of each duct diagram.
23. One (1) copy of control diagram.
24. One (1) copy of each accepted shop drawing.
25. One (1) copy of software programs imputable or changeable on site.
26. Ordering information.
27. Training course material used to train DEN staff, including slides and other presentation material.
28. Provide the following information, unless the item is covered in the Manufacturer's Operation and Manual:
  - a. Manufacturer's parts list with catalog names, numbers, and illustrations.
  - b. A list of components that are replaceable by the City.
  - c. An exploded view of each piece of the equipment with part designations.
  - d. List of manufacturer's recommended spare parts, current prices, and recommended quantities for two years of operation.
  - e. List of special tools and test equipment required for the operation, maintenance, adjustment, testing and repair of the equipment, instruments



- and components.
- f. Scale and corrosion control procedures.
- g. Disassembly and re-assembly instructions.
- h. Troubleshooting and repair instructions.
- i. Calibration procedures.

#### **PART 4 - MEASUREMENT**

##### 4.1 METHOD OF MEASUREMENT

- A. No separate measurement shall be made for work under this Section.

#### **PART 5 - PAYMENT**

##### 5.1 METHOD OF PAYMENT

- A. No separate payment will be made for work under this Section.

END OF SECTION 017825

## **SECTION 017835 - WARRANTIES AND BONDS**

### **PART 1 - GENERAL**

#### 1.1 RELATED DOCUMENTS

- A. Drawings and general provisions of the Contract, including General and Special Conditions and other Division 01 Specification Sections, apply to this Section.

#### 1.2 SUMMARY

- A. The Work specified in this Section consists of preparing and submitting warranties and bonds required by the Contract and these Specifications.

#### 1.3 SUBMITTALS

- A. Refer to Technical Specifications Section 013300 "Submittal Procedures" and Section 013325 "Shop and Working Drawings, Product Data and Samples" for submittal procedures.

- 1. All warranties shall be executed specifically to the City.
- 2. Photocopies or reproductions of stock manufacturer's warranties will not be accepted, although electronic copies are acceptable when the manufacturer's warranty is contained in the O&M manual.

- B. Submit samples of warranties and bonds for review by the City prior to execution of Work. Do not submit final warranties until sample warranties have been approved by the City.

- 1. Submit the warranties and bonds required by the Contract Documents.
- 2. Prepare and submit a list of all warranties and bonds on the following forms:

- a. CM-10: Contractor Warranty
- b. CM-11: Contractor/Sub-Contractor Warranty

- C. Submit executed warranties and bonds

## **PART 2 - PRODUCTS (NOT USED)**

## **PART 3 - EXECUTION**

### **3.1 WARRANTIES AND BONDS**

- A. Submit executed warranties and bonds required by the Contract Documents, as detailed in Title 15 - Performance and Payment Bonds and Title 18 - Warranties, Guarantees, and Corrective Work in the General Contract Conditions, 2011 Edition.

1. Prepare and submit a list of all warranties and bonds on the following forms:
  - a. CM-10, Contractor Warranty
  - b. CM-11, Contractor/Sub-Contractor Warranty

## **PART 4 - MEASUREMENT**

### **4.1 METHOD OF MEASUREMENT**

- A. No separate measurement shall be made for work under this Section.

## **PART 5 - PAYMENT**

### **5.1 METHOD OF PAYMENT**

- A. No separate payment will be made for work under this Section.

END OF SECTION 017835

## SECTION 017840 - CONTRACT RECORD DOCUMENTS

### PART 1 - GENERAL

#### 1.1 RELATED DOCUMENTS

- A. Drawings and general provisions of the Contract, including General and Special Conditions and other Division 01 Specification Sections, apply to this Section.

#### 1.2 SUMMARY

- A. The Work specified in this Section consists of maintaining, marking, recording, and submitting Contract record documents that include shop drawings, warranties, Contract Documents, and contractor records.
- B. Refer to DEN Building Information Modeling (BIM) Design Standards Manual (DSM) and Approved BIM execution for data format and file types acceptable for different type of data.
- C. Related Requirements:
  - 1. Section 013100 "Project Management and Coordination".
  - 2. Section 013223 "Construction Layout, As-built and Quantity Surveys".
  - 3. Section 013300 "Submittal Procedures".
  - 4. Section 013325 "Shop and Working Drawings, Product Data and Samples".
  - 5. Section 017720 "Contract Closeout".
  - 6. Section 017825 "Operation and Maintenance Data".

#### 1.3 SUBMITTALS

- A. Each submittal of record documents shall contain the following information:
  - 1. Date.
  - 2. Project title and numbers.
  - 3. Contractor's name and address.
  - 4. Title and number of each record document.
  - 5. Certification that each document as submitted is complete and accurate.
  - 6. Signature of the Contractor or the Contractor's authorized representative.
- B. At the completion of this Contract, deliver all record documents including the following:
  - 1. As-built shop drawings, diagrams, illustrations, schedules, charts, brochures and other similar data.
  - 2. Warranties, guarantees, and bonds.
  - 3. Contract Documents.
  - 4. Contractor records.

- C. As-built Contract Drawings shall be submitted with each monthly progress payment application, and a complete set shall be submitted prior to final payment.
  - 1. The Contractor shall provide a single electronic copy of each Contract drawing sheet which has been used to produce work during the payment period or work that payment is being requested on, which records the current as-built conditions of work, including the posting of any change orders or change directives not shown on the Contract Documents at the time of Contract signing.
    - a. The Contractor must show as-built work completed through the payment application date including but not limited to utilities, empty conduit, conduit for actual electrical lines, plumbing, HVAC, location of anchor bolts and support points for use by others.
    - b. The Contractor shall be liable for any costs incurred by the City or a third party due to errors or lack of information provided on the as-built drawings.
    - c. All markings on drawings shall be legible to identify the portion of work completed.
    - d. For projects utilizing BIM system by the Contractor or a consultant of the Contractor, all data formats shall be compatible and as approved by the BIM execution plan as required in the DEN BIM DSM.

#### 1.4 QUALITY CONTROL

- A. Submit electronically scanned copies of all documents required by Chapter 17 “Special Inspection and Testing” of the International Building Code 2009 as amended by City and County of Denver 2011. Keep scale and clarify dimension where electronic copies are not as originally scaled and dimensioned.
- B. For projects utilizing BIM for Revit, follow approved BIM execution plan and DEN BIM DSM for record documents, formats, and quality control and assurance procedures.

### **PART 2 - PRODUCTS (Not Used)**

### **PART 3 - EXECUTION**

#### 3.1 MAINTENANCE OF DOCUMENTS

- A. The Contractor must follow all the procedures established in the Contract Documents and DEN BIM DSM.
- B. The Contractor shall maintain at the work site on a current basis one (1) record copy of all drawings, specifications, addenda, change orders, approved shop drawings, working drawings, product data and samples in good order and marked currently to record all changes made during construction.
- C. Maintain at the field office one copy of the following record documents:

1. Contract Documents:

- a. Contract Drawings with all clarifications, requests for information, directives, changes, and as-built conditions clearly posted.
- b. Contract Specifications with all clarifications, requests for information, changes, directives and record of manufacturer actually used along with product trade name.
- c. Reference Standards in accordance with Section 014225 "Referenced Standards".
- d. Affirmative Action Plan and documents.
- e. One (1) set of drawings to record the following:
  - 1) Horizontal and vertical location of underground utilities affected by the Work.
  - 2) Location of internal utilities; include valves, controls, conduit, duct work, switches, pressure reducers, size reducers, transitions, crosses, tees, filters, motors, heaters, dampers, regulators, safety devices, sensors, access doors and appurtenances that are concealed in the construction shall be shown with dimensions given from a visible and recognizable reference to the item being located in all three dimensions. The drawings shall also reference the applicable submittal for the item being located.
  - 3) Field changes of dimensions and details including as-built elevations and location (station and offset).
  - 4) Details not on original Contract Drawings but obtained through requests for information or by other communications with the City.

2. Contractor Records:

- a. Daily Quality Control Reports.
- b. Certificates of compliance for materials used in construction.
- c. Completed inspection list.
- d. Inspection and test reports.
- e. Test procedures.
- f. Qualification of personnel.
- g. Approved submittals.
- h. Material and equipment storage records.
- i. Safety Plan
- j. Erosion, sediment, hazardous and quality plans.
- k. Hazardous material records.
- l. First report of injuries.

3.2 RECORDINGS

- A. Label each document page or article "PROJECT RECORD" in two-inch high letters.
- B. Keep record documents current daily.
- C. Legibly mark copies of the Contract Drawings to record actual construction.

- D. Legibly mark up each Section of the specifications and Contract Drawings to record:
1. Manufacturer, trade name, catalog number and supplier of each product and item actually installed
  2. Changes made by change orders, requests for information, substitutions, and variations approved by submittals.

### 3.3 DOCUMENT MAINTENANCE

- A. Follow all the required processes of the approved BIM Execution Plan as approved by DEN for this specific project or in formats acceptable to DEN BIM management system.
- B. Do not use record documents for construction purposes.
- C. Make documents available for inspection by the DEN Project Manager and any others having jurisdiction.

### 3.4 MONTHLY REVIEW

- A. Prior to any application for payment, the DEN Project Manager or the DEN Project Manager's designated representative will inspect the record documents to ensure that they are being maintained and contain the most current correct data with particular attention to as-built drawings.
- B. If, during the inspection, the DEN Project Manager determines that the documents are not being maintained and kept current as to as-built conditions, an amount may be withheld from the payment request and deducted from the Contract value to cover the City's cost of collecting and recording the as-built Contract data. This cost will be determined based on \$100.00 per man-hour of effort.

## PART 4 - MEASUREMENT

### 4.1 METHOD OF MEASUREMENT

- A. No separate measurement shall be made for work under this Section.

## PART 5 - PAYMENT

### 5.1 METHOD OF PAYMENT

- A. No separate payment will be made for work under this Section.

END OF SECTION 017840

## SECTION 017900 - DEMONSTRATION AND TRAINING

### PART 1 - GENERAL

#### 1.1 RELATED DOCUMENTS

- A. Drawings and general provisions of the Contract, including General and Special Conditions and other Division 01 Specification Sections, apply to this Section.

#### 1.2 SUMMARY

- A. Section includes administrative and procedural requirements for instructing City's personnel, including the following:
  - 1. Demonstration of operation of systems, subsystems, and equipment.
  - 2. Training in operation and maintenance of systems, subsystems, and equipment.
  - 3. Demonstration and training video recordings.

#### 1.3 INFORMATIONAL SUBMITTALS

- A. Instruction Program: Submit outline of instructional program for demonstration and training, including a list of training modules and a schedule of proposed dates, times, length of instruction time, and instructor's names for each training module. Include learning objective and outline for each training module.
  - 1. Indicate proposed training modules using manufacturer-produced demonstration and training video recordings for systems, equipment, and products in lieu of video recording of live instructional module.
- B. Qualification Data: For **[instructor]**.
- C. Attendance Record: For each training module, submit list of participants and length of instruction time.
- D. Evaluations: For each participant and for each training module, submit results and documentation of performance-based test.

#### 1.4 CLOSEOUT SUBMITTALS

- A. Demonstration and Training Video Recordings: Submit **two (2)]** copies within **seven (7)** days of end of each training module.
  - 1. Identification: On each copy, provide an applied label with the following information:



- a. Name of Project.
  - b. Name and address of videographer.
  - c. Name of Architect.
  - d. Name of Construction Manager.
  - e. Name of Contractor.
  - f. Date of video recording.
2. Closed Caption: Videos shall contain a visible text version of all speech provided in the recording.
  3. Transcript: Prepared and bound in format matching operation and maintenance manuals. Mark appropriate identification on front and spine of each binder. Include a cover sheet with same label information as the corresponding video recording. Include name of Project and date of video recording on each page.
  4. Transcript: Prepared in PDF electronic format. Include a cover sheet with same label information as the corresponding video recording and a table of contents with links to corresponding training components. Include name of Project and date of video recording on each page.
  5. At completion of training, submit complete training manual(s) for City's use **prepared and bound in format matching operation and maintenance manuals and in PDF electronic file format**].

## 1.5 QUALITY ASSURANCE

- A. Facilitator Qualifications: A firm or individual experienced in training or educating personnel in a training program similar in content and extent to that indicated for this Project, and whose work has resulted in training or education with a record of successful learning performance.
- B. Instructor Qualifications: A professional instructor/trainer who is experienced in operation and maintenance procedures and training.
- C. Videographer Qualifications: A professional videographer who is experienced photographing demonstration and training events similar to those required.
- D. Preinstruction Conference: Conduct conference at Project site to comply with requirements in Section 014510 "Contractor Quality Control". Review methods and procedures related to demonstration and training including, but not limited to, the following:
  1. Inspect and discuss locations and other facilities required for instruction.
  2. Review and finalize instruction schedule and verify availability of educational materials, instructor's personnel, audiovisual equipment, and facilities needed to avoid delays.
  3. Review required content of instruction.
  4. For instruction that must occur outside, review weather and forecasted weather conditions and procedures to follow if conditions are unfavorable.

## 1.6 COORDINATION

- A. Coordinate instruction schedule with City's operations. Adjust schedule as required to minimize disrupting City's operations and to ensure availability of City's personnel.
  - 1. Include multiple classes to accommodate various shifts, as necessary.
- B. Coordinate instructors, including providing notification of dates, times, length of instruction time, and course content.
- C. Coordinate content of training modules with content of approved emergency, operation, and maintenance manuals. Do not submit instruction program until operation and maintenance data has been reviewed and approved by DEN Project Manager.

## PART 2 - PRODUCTS

### 2.1 INSTRUCTION PROGRAM

- A. Program Structure: Develop an instruction program that includes individual training modules for each system and for equipment not part of a system, as required by individual Specification Sections.
- B. Training Modules: Develop a learning objective and teaching outline for each module. Include a description of specific skills and knowledge that participant is expected to master. For each module, include instruction for the following as applicable to the system, equipment, or component:
  - 1. Basis of System Design, Operational Requirements, and Criteria: Include the following:
    - a. System, subsystem, and equipment descriptions.
    - b. Performance and design criteria if Contractor is delegated design responsibility.
    - c. Operating standards.
    - d. Regulatory requirements.
    - e. Equipment function.
    - f. Operating characteristics.
    - g. Limiting conditions.
    - h. Performance curves.
  - 2. Documentation: Review the following items in detail:
    - a. Emergency manuals.
    - b. Operations manuals.
    - c. Maintenance manuals.
    - d. Project record documents.
    - e. Identification systems.
    - f. Warranties and bonds.

- g. Maintenance service agreements and similar continuing commitments.
3. Emergencies: Include the following, as applicable:
  - a. Instructions on meaning of warnings, trouble indications, and error messages.
  - b. Instructions on stopping.
  - c. Shutdown instructions for each type of emergency.
  - d. Operating instructions for conditions outside of normal operating limits.
  - e. Sequences for electric or electronic systems.
  - f. Special operating instructions and procedures.
4. Operations: Include the following, as applicable:
  - a. Startup procedures.
  - b. Equipment or system break-in procedures.
  - c. Routine and normal operating instructions.
  - d. Regulation and control procedures.
  - e. Control sequences.
  - f. Safety procedures.
  - g. Instructions on stopping.
  - h. Normal shutdown instructions.
  - i. Operating procedures for emergencies.
  - j. Operating procedures for system, subsystem, or equipment failure.
  - k. Seasonal and weekend operating instructions.
  - l. Required sequences for electric or electronic systems.
  - m. Special operating instructions and procedures.
5. Adjustments: Include the following:
  - a. Alignments.
  - b. Checking adjustments.
  - c. Noise and vibration adjustments.
  - d. Economy and efficiency adjustments.
6. Troubleshooting: Include the following:
  - a. Diagnostic instructions.
  - b. Test and inspection procedures.
7. Maintenance: Include the following:
  - a. Inspection procedures.
  - b. Types of cleaning agents to be used and methods of cleaning.
  - c. List of cleaning agents and methods of cleaning detrimental to product.
  - d. Procedures for routine cleaning
  - e. Procedures for preventive maintenance.
  - f. Procedures for routine maintenance.
  - g. Instruction on use of special tools.

8. Repairs: Include the following:
  - a. Diagnosis instructions.
  - b. Repair instructions.
  - c. Disassembly; component removal, repair, and replacement; and reassembly instructions.
  - d. Instructions for identifying parts and components.
  - e. Review of spare parts needed for operation and maintenance.

### PART 3 - EXECUTION

#### 3.1 PREPARATION

- A. Assemble educational materials necessary for instruction, including documentation and training module. Assemble training modules into a training manual organized in coordination with requirements in Section 017825 "Operation and Maintenance Data."
- B. Set up instructional equipment at instruction location.

#### 3.2 INSTRUCTION

- A. Facilitator: Engage a qualified facilitator to prepare instruction program and training modules, to coordinate instructors, and to coordinate between Contractor and City for number of participants, instruction times, and location.
- B. Engage qualified instructors to instruct City's personnel to adjust, operate, and maintain systems, subsystems, and equipment not part of a system.
  1. Contractor will furnish an instructor to describe basis of system design, operational requirements, criteria, and regulatory requirements.
  2. City will furnish an instructor to describe City's operational philosophy.
  3. DEN Project Manager will furnish Contractor with names and positions of DEN participants.
- C. Scheduling: Provide instruction at mutually agreed on times. For equipment that requires seasonal operation, provide similar instruction at start of each season.
  1. Schedule training with City, through DEN Project Manager, with at a minimum of **thirty (30)** days advance notice.
- D. Training Location and Reference Material: Conduct training on-site in the completed and fully operational facility using the actual equipment in-place. Conduct training using final operation and maintenance data submittals.
- E. Evaluation: At conclusion of each training module, assess and document each participant's mastery of module by use of **a written]** or a **demonstration** performance-based test.

- F. Cleanup: Collect used and leftover educational materials and **give to City**. Remove instructional equipment. Restore systems and equipment to condition existing before initial training use.

### 3.3 DEMONSTRATION AND TRAINING VIDEO RECORDINGS

- A. General: Engage a qualified commercial videographer to record demonstration and training video recordings. Record each training module separately. Include classroom instructions and demonstrations, board diagrams, and other visual aids, but not student practice.
1. At beginning of each training module, record each chart containing learning objective and lesson outline.
- B. Video Recordings: Submit video recordings in an electronic format acceptable to DEN Project Manager **by posting to Project Web site**. Recordings shall be high-resolution **4k** with a minimum framerate of 60Hz
1. File Names: Utilize file names based upon name of equipment generally described in video segment, as identified in Project specifications.
  2. Contractor and Installer Contact File: Using appropriate software, create a file for inclusion on the Equipment Demonstration and Training DVD that describes the following for each Contractor involved on the Project:
    - a. Name of Contractor/Installer.
    - b. Business address.
    - c. Business phone number.
    - d. Point of contact.
    - e. E-mail address.
- C. Recording: Mount camera on tripod before starting recording, unless otherwise necessary to adequately cover area of demonstration and training. Display continuous running time.
1. Film training session(s) in segments not to exceed 15 minutes.
    - a. Produce segments to present a single significant piece of equipment per segment.
    - b. Organize segments with multiple pieces of equipment to follow order of Project Manual table of contents.
    - c. Where a training session on a particular piece of equipment exceeds 15 minutes, stop filming and pause training session. Begin training session again upon commencement of new filming segment.
- D. Light Levels: Verify light levels are adequate to properly light equipment. Verify equipment markings are clearly visible prior to recording.
1. Furnish additional portable lighting as required.
- E. Narration: Describe scenes on video recording by **audio narration by microphone**

**while or dubbing audio narration off-site after]** video recording is recorded. Include description of items being viewed.

1. Closed Caption: Videos shall contain a visible text version of all speech provided in the recording.
  2. Transcript: Prepared and bound in format matching operation and maintenance manuals. Mark appropriate identification on front and spine of each binder. Include a cover sheet with same label information as the corresponding video recording. Include name of Project and date of video recording on each page.
  3. Transcript: Prepared in PDF electronic format. Include a cover sheet with same label information as the corresponding video recording and a table of contents with links to corresponding training components. Include name of Project and date of video recording on each page.
- F. Transcript: Provide a transcript of the narration. Display images and running time captured from videotape opposite the corresponding narration segment.
- G. Failure of Video Recordings: If video recordings submitted by Contractor do not comply with Project requirements, or have audio and/or video problems, Contractor will be required to repeat training and video recording in compliance with this Section in order to re-create the training video.

#### **PART 4 - MEASUREMENT**

##### 4.1 METHOD OF MEASUREMENT

- A. No separate measurement shall be made for work under this Section.

#### **PART 5 - PAYMENT**

##### 5.1 METHOD OF PAYMENT

- A. No separate payment will be made for work under this Section.

END OF SECTION 017900



## **SECTION 019113 - GENERAL COMMISSIONING REQUIREMENTS**

### **PART 1 - GENERAL**

#### **1.1 RELATED DOCUMENTS**

- A. Drawings and general provisions of the Contract, including General and Special Conditions and other Division 01 Specification Sections, apply to this Section.
- B. Specification Sections:
  - 1. Section 013100 – Project Management and Coordination
  - 2. Section 013119 – Project Meetings
  - 3. Section 013300 – Submittal Procedures
  - 4. Section 014510 – Contractor Quality Control
  - 5.

#### **1.2 SUMMARY**

- A. Scope
  - 1. Commissioning requirements common to all Sections
  - 2. Systems and equipment functional performance testing
  - 3. Validation of proper and thorough installation of systems and equipment
  - 4. Equipment performance verification
  - 5. Documentation of tests, procedures, and observations.
  - 6. Review of DEN Training agency.
- B. Section includes general requirements that apply to implementation of commissioning without regard to specific systems, assemblies, or components.
- C. Related Sections

#### **1.3 DEFINITIONS**

- A. Acceptance Phase: The phase of the project when the facility and its systems and equipment are inspected, tested, verified, and documented; and when most of the Functional Performance Testing and formal training occurs. This will generally occur after the Construction Phase is complete (start-up and checks have been accomplished). The Acceptance Phase typically begins with Substantial Completion and ends with Final I Completion.
- B. Commissioning Authority (CA or CxA): The Party retained by DEN who will oversee the Commissioning process as well as develop and stipulate many of the Commissioning requirements. They will also manage the Commissioning process, and ensure and validate that systems and equipment are designed, installed, and tested to



meet DEN's requirements.

- C. Commissioning Contact (CxC): Individuals, appointed by the installing contractor, each having the authority to act on behalf of the entity he or she represents, explicitly organized to implement the commissioning process through coordinated action.
- D. Commissioning Plan: A document that outlines the organization, schedule, allocation of resources, and documentation requirements of the commissioning process.
- E. Construction Phase: Phase of the project during which the facility is constructed and/or systems and equipment are installed and started. Contractor and subcontractors complete the installation, complete start-up documentation, submit operation and maintenance information, establish trends, and perform any other applicable requirements to get systems started. Contractor and Vendors may also conduct equipment specific training. The Construction Phase will generally end upon Substantial Completion.
- F. Contractor: As used herein, 'Contractor' is a general reference to the installing Party and can therefore refer to the General Contractor, subcontractors, or vendors as inferred by its usage.
- G. Deficiency: A condition in the installation or function of a component, piece of equipment or system that does not comply with the Contract Documents, i.e., does not perform properly or is not complying with the design intent.
- H. the equipment and certified by the manufacturer to perform the respective task.
- I. Factory Testing: Testing of equipment off-site at the manufacturer's facility. The testing may be witnessed by the members of the project team.
- J. Functional Performance Testing (FPT): The detailed and thorough testing of building systems and their interactions with building components and other building systems.
- K. Issue Log: This list is maintained and updated by the Commissioning Authority that includes all Issue items that relate to Commissioning activities and site observations requiring contractor action or response.
- L. Maximum Failure Limit: The maximum percentage of a test population that is permitted to fail before the test is considered a failure and subject to correction and retesting. Where test sampling is used, the Maximum Failure Limit shall be the maximum percentage of a test sample that is permitted to fail before an entirely new sample must be selected for testing.
- M. Operation and Maintenance (O&M) Documentation: Contractor-developed documentation designed to address the needs of facilities personnel and customized for the context of the specific facility and installation. This includes manufacturer's literature (including O&M manuals, parts lists, troubleshooting guides, etc.), Contractor-developed instructions for start-up and shut-down, control sequences, and other installation-specific information.

- N. Pre-Start Up: Preliminary testing accomplished during a scheduled system outage to verify system functionality prior to placing the system/equipment into preliminary service.
- O. Start-Up: Refers to the quality control process whereby the Contractor verifies the proper installation of a device or piece of equipment, executes the manufacturer's starting procedures, completes the Start-Up Checklist, energizes the device, verifies that it is in proper working order and ready for dynamic testing, including Start-Up Tests.
- P. Systems, Subsystems, Equipment, and Components: Where these terms are used together or separately, they shall mean "as-built" systems, subsystems, equipment, and components.
- Q. Test, Adjust, and Balance (TAB): Refers to the test, adjust, and balance process or the Testing, Adjusting, and Balancing Contractor.

#### 1.4 ACTION SUBMITTALS

##### A. General requirements:

1. Provide individual checklists and procedures for each system or component.
2. Develop individual checklists and procedures for each tagged piece of equipment. General procedures developed for multiple pieces of equipment, including similar equipment, are not acceptable.
3. Procedures and checklists for specified phases of commissioning (e.g. Pre-startup, startup, functional performance testing) must be submitted and approved prior to commencement of the related activity.

##### B. CxA submittals:

1. Commissioning plan.
2. Pre-functional checklists: For each system or component.
3. Startup procedures: For each system or component.
4. Startup checklists: For each system or component.
5. Completed startup checklists: For each system or component.
6. Functional Test Procedures: For each system or component.
7. Functional Test Checklists: For each system or component.
8. Formal acceptance recommendation for each component or system tested, following successful completion of testing.

##### C. Contractor submittals:

1. Completed pre-functional checklists: For each system or component.
2. Completed startup checklists: For each system or component.
3. Completed functional test checklists: For each system or component.

#### 1.5 INFORMATIONAL SUBMITTALS

A. CxA submittals:

1. Qualifications: For CxA and testing technicians.
2. Test equipment calibration certificates.
3. Preliminary Commissioning Report, including the following:
  - a. Compiled test results.
  - b. Updated Issues Log.
  - c. Updated Checklist log.
4. Final Commissioning Report, including the following:
  - a. Compiled test results.
  - b. Seasonal test results.
  - c. Warranty walkthrough results.
  - d. Completed issues log.
  - e. Completed checklist log.

1.6 COMMISSIONING TEAM

A. Members Appointed by Contractor(s):

1. Contractor shall appoint a CxC.
2. The commissioning team shall consist of, but not be limited to, representatives of **each** Contractor, including Project superintendent and subcontractors, installers, suppliers, and specialists deemed appropriate by the CxA.

B. Members Appointed by DEN Project Manager:

1. CxA: The designated person, company, or entity that plans, schedules, and coordinates the commissioning team to implement the commissioning process. DEN will engage the CxA under a separate contract.
2. Representatives of DEN Sustainability, DEN Project Manager Representative, and DEN Maintenance personnel.
3. Architect and engineering design professionals.

1.7 DEN'S RESPONSIBILITIES

- A. Assign DEN Sustainability and Operations Maintenance personnel and schedule them to participate in commissioning team activities.
- B. Coordinate activities specified in paragraph below with DOR and Architect-Consultant agreements.
- C. Provide the BoD documentation, prepared by DOR, and approved by DEN, to the CxA and **each** Contractor for use in developing the commissioning plan, systems manual, and operation and maintenance training plan.

## 1.8 EACH CONTRACTOR'S RESPONSIBILITIES

- A. **Each** Contractor shall assign representatives with expertise and authority to act on its behalf and shall schedule them to participate in and perform commissioning process activities including, but not limited to, the following:
1. Include Commissioning requirements in price and plan for work.
  2. Evaluate performance deficiencies identified in test reports and, in collaboration with entity responsible for system and equipment installation, recommend corrective action.
  3. Cooperate with the CxA for resolution of issues recorded in the Issues Log.
  4. Attend commissioning team meetings held on a **weekly** basis and progressing to weekly meetings as construction project nears completion.
  5. Integrate and coordinate commissioning process activities with construction schedule.
  6. Review and accept construction pre-functional checklists provided by the CxA prior to commencing functional testing.
  7. Complete electronic construction checklists as Work is completed and provide to the DEN Project Manager after each checklist has been completed.
  8. Review and accept commissioning process functional test procedures provided by the Commissioning Authority.
  9. Designate a CxC from each major subcontractor with activities related to commissioning. These CxCs are to be the primary contacts for Commissioning activities.
  10. Contractor shall incorporate the Commissioning process into the construction schedule, outlining generic Commissioning tasks with precedents or prerequisites to each task. These tasks will apply to many systems and the Contractor shall incorporate as such. Examples of enumerated tasks include, but are not limited to:
    - a. Contractor preparation of the Training Plan
    - b. Testing Agency activities
    - c. Contractor documentation of pipe pressure testing, flushing, and cleaning of applicable systems
    - d. Documentation of the Start-Up Procedures for equipment and systems
    - e. TAB of applicable system
    - f. Preparation of the O&M Manual content
    - g. FPT and Acceptance
    - h. Observation Period and System Optimization
    - i. Occupant or other Regulatory Agency testing or approval process
  11. Assist the CxA in preparation for the specific FPT procedures. Contractors, subcontractors, and vendors shall review the FPTs to ensure feasibility, safety, and equipment protection and provide necessary written alarm limits to be used during the tests. Damage caused to equipment performed in accordance with the approved procedures that is the result of malfunctioning equipment or contract deficiencies, shall be the responsibility of the Contractor.
  12. Record start-up and testing procedures.
  13. Demonstrate the operation of all systems as specified.

- a. Operate systems, with assistance of DEN Maintenance, under direction of the CxA during FPT's and other acceptance testing.
- B. Acceptance Phase: The following delineates the commissioning-related responsibilities of the Contractor (and their subcontractors) during the Acceptance Phase.
1. Work in conjunction with CxA in FPT and shall include, but not limited to the following:
    - a. Operate and Manipulate systems and equipment to facilitate testing (as dictated in this section, relevant technical sections and the Commissioning Plan).
    - b. Operate and Manipulate EMCS and other control systems to facilitate FPT (as dictated in this section, relevant technical sections and the Commissioning Plan).
  2. Correct any work not in accordance with Contract Documents.
  3. Maintain record documentation and update and resubmit it after Functional Completion.
  4. Compensate DEN for additional CxA fees and expenses incurred to retest equipment and systems following testing failures.
  5. Monitor systems, equipment, and areas throughout the Transition Period. Log and diagnose all alarms during this period. Maintain trends and logs of all critical parameters. Forward the logs and trends on a weekly basis throughout all Transition Periods.
- C. Warranty Period: The following delineates the commissioning-related responsibilities of the Contractor (and their subcontractors) during the Warranty Period.
1. Provide warranty service
  2. Conduct EMCS Sequence Training
  3. Respond to and document Warranty issues
  4. Correct any deficiencies identified throughout the Warranty Period
  5. Update record documentation to reflect any changes made throughout the Warranty Period and resubmit final Record Drawings and data records at the close of the Warranty period
- 1.9 CxA'S RESPONSIBILITIES
- A. Organize and lead the commissioning team through the entire project.
  - B. Provide and update **construction phase** commissioning plans.
  - C. Convene commissioning team meetings to discuss commissioning activities and current issues and resolutions.
  - D. Provide Project-specific construction checklists and commissioning process test procedures.
  - E. Review all pertinent equipment submittals, shop drawings, and O&M documentation.

- F. Verify the execution of commissioning process activities. Verification will include, but is not limited to, equipment submittals, construction checklists, training, operating and maintenance data, tests, and test reports to verify compliance with the DPR. When a requirement is not met, the CxA will report the failure in the Issues Log.
- G. Prepare and maintain the Issues Log.
- H. Prepare and maintain completed construction checklist log.
- I. Organize and lead the functional, seasonal, any LEED required tests, and 10-month Warranty review in the presence of the contractor, DEN Maintenance, and DEN PM assigned personnel.
- J. Witness systems, assemblies, equipment, and component startup.
- K. Compile test data, inspection reports, and certificates; include them in the systems manual and commissioning process report.

#### 1.10 ISSUES LOG

- A. CxA shall maintain an Issues Log (required information, identified deficiencies, work required, etc.) that relates to Commissioning. Each item shall be tracked with the initiator, the parties responsible, due date, the date of closure, and a description of the resolution. Each item shall be categorized for sorting and tracking and for documentation on applicable forms.
- B. CxA will provide this list to the DEN Project Manager during regular project meetings as appropriate to keep all parties informed.
- C. All parties indicated as responsible for an action item shall respond to the DEN Project Manager. Responses are due within 10 days of action items being identified to the team.

#### 1.11 PRE-START UP

##### A. PREREQUISITES

- 1. All equipment, components, and devices applicable to the Pre-Start Up must be installed, and the Pre-Start Up must be documented and approved. This includes installation, identification labeling, insulation, and all other requirements for placing systems into dynamic operation.

##### B. COMMON ELEMENTS

- 1. Required submittal documentation shall be present and located convenient to testing area.
- 2. Contractor shall submit the completed Pre-Start Up Procedures at least 10 days prior to the start of Functional testing. CxA shall review the Pre-Start Up Procedure documentation at the beginning of Start Up. Contractor shall

demonstrate to DEN Project Manager, DEN Maintenance and DEN Sustainability that access is sufficient to perform required maintenance.

3. System and equipment configurations shall be compared against the contract documents.

## 1.12 INSTRUMENTATION

- A. All test instruments described in this section shall be acceptable for any portion of the commissioning process herein described.
- B. All instruments shall conform to the standards specified in the most recent edition of "NEBB Procedural Standards for Testing, Adjusting, and Balancing of Environmental Systems" in regard to accuracy and calibration status. Current calibration certificates must be available to the CxA if requested.
- C. Test instrument accuracy and resolution must match or exceed that of the system component being verified or calibrated.
- D. Test instruments must be used within guidelines as recommended by instrument manufacturer. All measuring methods must be appropriate to the instrument application and measurements must be repeatable under equivalent conditions.
- E. Standard Testing Instrumentation: Standard instrumentation normally used for performance assessment and diagnosis shall be provided by testing entity. These include, but are not limited to:
  1. Electronic Manometer (for Air and Flow Hood)
  2. Electronic Manometer (for Water)
  3. Temperature Instruments
  4. **Pressure instruments**
  5. Humidity Instruments
  6. CO2 Instrument
  7. Sound Meter
  8. Electronic Multimeter
  9. Tachometer
  10. Ultrasonic Flow Meter
  11. Others as required

## 1.13 START-UP

- A. Prerequisites
  1. All equipment, components, and devices applicable to the FPT must be started, and the Start-Up must be documented and approved. This includes completion of Start-Up Procedures, pressure testing (of equipment, duct and piping), flushing/cleaning, identification labeling, insulation, and all other requirements for placing systems into dynamic operation.
  2. Unless specifically agreed to by DEN and CxA, all support systems shall be

- complete prior to FPT.
3. The CxA shall determine the optimal sequence of testing.

B. Common Elements

1. Required submittal documentation shall be present and located convenient to testing area. Validate that all required documentation has been submitted and **complete** per the contract requirements.
2. Contractor shall provide the completed Start-Up Procedures at the time of testing. CxA shall review the Start-Up Procedure documentation and spot-check at the beginning of FPT.

C. Procedure

1. Purpose:
  - a. Verify adherence to, and documentation of, quality control processes involved with preparing systems and equipment for operation.
  - b. These procedures shall be performed on all installed systems and equipment and no sampling strategy is used for the start-up process.
  - c. The Commissioning process requires all Parties to collaborate to establish the optimal standard of care for starting systems and equipment.
  - d. After the procedures are established, the Contractor performs them and documents them with the Start-up Procedures that are developed by the Contractor.
2. Start-Up Procedures: The content of these Start-Up Procedures shall provide the minimally acceptable content in accordance with the OEM field quality control requirements. Generic refers to the fact that the protocols may be created before the shop drawings are finalized. These procedures and protocols will normally be common across different manufacturers.
3. Content of Start-Up Procedures: Start-Up Procedures shall generally include the following for each item of equipment or system (as applicable):
  - a. Project-specific designation, location, and service.
  - b. Indication of the Party performing and documenting the Start-Up Procedure.
  - c. Clear explanation of the inspection, test, measurement, and outcome with a Pass/Fail indication and a record of measure parameters.
  - d. A Start-up Checklist item indicating that proper maintenance clearances have been maintained.
4. Recording and Documentation of Factory Start-Up: Manufacturer's start-up protocols shall be executed and forms shall be completed by a qualified/authorized technician.
5. Recording and Documentation of non-Factory Start-Up: The start-up tests and checklists shall be completed by a qualified technician.
6. Commissioning Authority Review: CxA will review and spot-check procedures during FPT.
7. Documentation Completion: The individual executing the start-up must complete the start-up and pre-functional documentation for any given equipment and



- acknowledge acceptability with the indication of who did the associated task.
8. Sampling and Final Submission: All (100% of) systems are started and documented per the approved procedures and NO sampling strategy is used. Completed Start-up and pre-functional checklists for all pieces of equipment associated with independent systems shall be submitted to CxA prior to any associated FPT. Any outstanding item shall be clearly indicated and an associated Action Item must be entered to track resolution.
  9. DEN Access: Contractor shall allow access by DEN representatives to inspect the equipment and ensure its proper operation.

#### 1.14 TEST, ADJUST, AND BALANCE

- A. CxA shall review TAB reports.
- B. The CxA shall select up to 10% of the readings from the Balancing Reports and verify performance readings. Readings selected by the CxA may include:
  1. Supply air diffuser readings (both minimum and maximum readings for variable air volume boxes).
  2. Main and branch supply duct traverse readings.
  3. Outside/return air flow readings.
  4. Exhaust airflow readings.
  5. Water flow readings.
  6. Ampere readings.
  7. Water pressure drop readings through coils, heat exchangers, and other hydronic elements.
- C. For all readings, a deviation of more than 10% between the verification reading and reported data shall be considered as failing the FPT. The maximum failure rate for the sample is 10%.
- D. If greater than 10% of sample readings have failed, the TAB contractor shall justify all noted failures or rebalance and re-document the system.

#### 1.15 FUNCTIONAL PERFORMANCE TESTING

- A. Objectives and Scope
  1. Demonstrate that each system is operating according to the documented design intent and Contract Documents.
  2. Bring all commissioned systems from a state of substantial completion to full dynamic operation.
  3. Identify and correct performance deficiencies.
  4. Operate each system through all modes of operation (seasonal, occupied, unoccupied, warm-up, cool-down, normal and emergency power, fire alarm, part-and full-load) where there is a specified system response.
  5. Verify each sequence in the sequences of operation as required.
  6. Verify responses to abnormal operational modes and conditions, such as power

failure, freeze conditions, no flow, equipment failure, etc..

B. Development of Test Procedures

1. CxA shall develop specific test procedures to verify and document proper operation of each piece of equipment and system.
2. CxA shall develop fill-in forms for use during FPT, based on the test procedures.
3. Not less than 14 days prior to execution of FPT, CxA shall submit completed test procedures to the DEN Project Manager to review the tests for feasibility, safety, equipment and warranty protection, and scope.
4. EMCS trends shall have been established as required in the documents. These shall generally be reviewed prior to or during FPT.
5. Capacities and adjusted/balanced conditions as applicable shall be subject to review.
6. Sequencing Verification: For applicable systems and equipment, all modes of operation shall be verified for proper sequencing.
7. System and equipment configurations shall be compared against the contract documents.
8. All adjusted, balanced, controlled systems shall be assessed to determine the optimal setting for the system as applicable. The optimal settings should be determined to establish reliable, efficient, safe, and stable operation.

C. Scheduling:

1. Contractor shall notify the CxA and the DEN Project Manager that systems are ready for testing, to schedule FPT.
2. To the extent practical, tests shall be scheduled to allow efficient and contiguous testing of inter-related systems and equipment.

D. Phasing:

1. Non-interdependent segments of the project testing may be phased.
2. Phasing of FPT for this project shall be coordinated between the CxA, Contractor, and the DEN Project Manager as the project progresses.

E. Participation:

1. CxA shall witness and document FPTs performed by the contractor after Start-Up Procedure documentation of systems and equipment has been reviewed and accepted.
2. Contractor shall perform the FPTs as described, with manipulation of the systems or equipment, provision of supporting equipment or materials (lifts, ladders, specialty test equipment, safety equipment), and on-the-spot remediation of minor identified deficiencies whenever possible.
3. Required participating Parties shall be indicated in the test plan for each individual FPT.
4. Required participating parties shall be available on-site throughout the testing of any given system for which they are required participants.
5. CxA shall coordinate effectively with the individual Contractors throughout FPT and minimize their required involvement.

F. Completeness:

1. All systems must be completed and ready for FPT at the time of the test.
2. All start up, factory authorized field testing, independent testing agency tests, and TAB procedures must be complete and the control systems must be tested and operational for the respective system or component.

G. Test Documentation:

1. CxA shall witness and document the tests.
2. CxA shall record all test results on the forms developed for the testing.
3. CxA shall 'Pass' or 'Fail' the testing and record the date and time of the test.
4. Deficiencies shall be clearly indicated when the test is failed.
5. When all related testing is completed successfully, CxA shall recommend acceptance of the system or component.
6. In the case of specialized testing, CxA shall witness and review the testing reports prepared by the Contractor.

H. Acceptance Criteria

1. The Acceptance Criteria shall be as follows unless specifically indicated within applicable individual specification sections or test procedures.
  - a. Accuracy/repeatability on sensing devices will be as specified for the device. CxA and TAB will use calibrated gauges for independent validation of sensing devices.
  - b. HVAC sequence-related criteria will be as specified in the documents.

I. Deficiencies

1. CxA shall record the results of each functional test. All deficiencies or non-conformance issues shall be brought to Contractor's attention immediately, noted in the Issues Log, and reported to the DEN Project Manager within 72 hours.
  - a. Corrections of identified minor deficiencies may be made during the tests where feasible. In such cases, the deficiency will be noted on the FPT documents.
  - b. Deficiencies with potential schedule or cost impacts shall be reported to the DEN Project Manager within 24 hours of discovery.
2. Contractor shall correct all identified deficiencies as directed by the DEN Project Manager.
  - a. CxA shall maintain Contractor's response to each deficiency in the Issues Log.
  - b. Contractor shall correct each deficiency, and notify CxA upon completion by completing an action item response.
  - c. Contractor shall schedule repeat testing and ensure CxA is available to observe.

3. Disputes:

- a. Contractor shall notify the DEN Project Manager and CxA immediately if the responsibility or nature of any identified deficiency is in dispute.
- b. The CxA shall document as a disputed deficiency in the Issues Log.
- c. The Contractor shall negotiate a resolution to the dispute with the DEN Project Manager.
- d. Upon resolution , CxA shall update the Issues Log to reflect the status of the deficiency

J. Sampling Percentage:

1. Sampling percentage shall be as indicated in the test plan.
2. Where no sampling percentage is indicated, the implied sampling percentage is 100% and all units shall be tested.

K. Maximum Failure Limit:

1. Maximum Failure Limit shall be as indicated in the test plan.
2. When the maximum number of failures is reached, testing on that sample will be terminated and re-testing will be scheduled.
3. If no Maximum Failure Limit is indicated, the implied failure limit is 0% and all tested samples must pass.
4. Where sample tests involve multiple systems (i.e., checking strainers on different hydronic systems), the Maximum Failure Limit will apply per system.
5. The responsible Contractors shall reimburse DEN for the CxA's cost of that sample test, and redo the start-up and TAB for the applicable devices/systems.
6. All work necessitated by sample failures shall be at no cost to DEN.

L. Manufacturer's Defects:

1. If 10% of identical pieces of equipment fail to perform to the Contract Documents (mechanically or substantively) due to a manufacturing defect, all identical units may be considered unacceptable by the DEN Project Manager.
2. For the purposes of defining 'identical equipment' for this Section, size or capacity alone does not constitute a difference.
3. In case of failure due to manufacturer's defects, the Contractor shall provide DEN with the following:
  - a. Manufacturer's response in writing as to the cause of the failure and proposed resolution.
  - b. Manufacturer shall implement their proposed resolution on a representative sample of the product.
  - c. The DEN Project Manager will determine whether a replacement of all identical units or a repair is acceptable.
  - d. Upon acceptance, the Contractor shall replace or repair all identical items at their expense and shall extend the warranty accordingly (if the original equipment warranty had begun).
  - e. Manufacturer shall pay the costs of all retesting necessitated by the failure.

## 1.16 CLOSEOUT

### A. Commissioning Report

1. A final summary report by the CxA shall be provided to the DEN Project Manager, focusing on evaluating commissioning process issues and identifying areas where the process could be improved.
2. Include all acquired documentation, logs, minutes, reports, deficiency lists, communications, findings, unresolved issues, etc., compiled in appendices, and provided with the summary report.
3. Pre-Start Up verification, Start Up checklists, TAB, functional tests, and monitoring reports shall not be included the final report, but shall be submitted as part of the Commissioning Record in the O&M manuals.

### B. Logs

1. CxA shall submit an updated Issues Log and all Issues Logs upon substantial completion of the project.

### C. Acceptance

1. CxA shall recommend acceptance of each test in writing to the DEN Project Manager.
2. The CxA shall note each satisfactorily demonstrated function on the test documentation.
3. Tests shall be considered accepted only upon formal acceptance by the DEN Project Manager.

### D. Training

1. The Contractor shall be responsible for training coordination and scheduling and ultimately for ensuring that training is completed.
2. The CxA shall witness the content and adequacy of the training of DEN personnel for commissioned equipment. Any issues shall be noted in the Issues Log and reported immediately to the DEN Project Manager.

### E. Operation and Maintenance Manual and Record Drawing Review

1. Prior to substantial completion, the CxA shall review the O&M manuals, documentation, and redlined as-built drawings for systems that were commissioned to verify compliance with the Specifications.
2. The CxA shall review completed record drawings and document any discrepancies in the Issues Log.

## 1.17 WARRANTY PERIOD

### A. Warranty Review

1. CxA, under direction from the DEN Project Manager and DEN Asset Management, shall participate in warranty walkthrough of all commissioned

systems.

2. The warranty walkthrough shall occur not less than ten (10) months following substantial completion, and not more than twelve (12) months following substantial completion.
3. The CxA shall document any deficiencies found during the warranty walkthrough in the Issues Log and notify the DEN Project Manager.

**B. Seasonal Testing**

1. During the warranty period, seasonal testing (tests delayed until weather conditions are closer to the system's design) shall be completed as part of this contract.
2. The CxA shall coordinate this activity with the DEN Project Manager and the Contractor.
3. Tests will be executed, documented and deficiencies corrected by the appropriate parties, with DEN maintenance staff and the CxA witnessing.
4. Any final adjustments to the O&M manuals and Record Drawings due to the testing will be made by the responsible parties.

**PART 2 - PRODUCTS (Not Used)**

**PART 3 - EXECUTION (Not Used)**

**PART 4 - MEASUREMENT**

**4.1 METHOD OF MEASUREMENT**

- A. No separate measurement shall be made for work under this Section.

**PART 5 - PAYMENT**

**5.1 METHOD OF PAYMENT**

- A. No separate payment will be made for work under this Section. .

**END OF SECTION 019113**



# PROJECT MANUAL



DENVER  
INTERNATIONAL  
AIRPORT

**Pond 001 Expansion**  
CONTRACT NO. 201737313

## PART II

### TECHNICAL SPECIFICATIONS

*Issued for Construction November 21, 2017*

CITY & COUNTY OF DENVER  
DEPARTMENT OF AVIATION





**TABLE OF CONTENTS  
TECHNICAL SPECIFICATIONS**

**DIVISION 2 – AIRFIELD STANDARDS**

| <u>SECTIONS</u> | <u>TITLE</u>  |
|-----------------|---|
| D-701           | PIPE FOR STORM DRAINS AND CULVERTS                  |
| D-705           | PIPE UNDERDRAINS FOR AIRPORTS                       |
| D-710           | ROCK RIPRAP   |
| D-751           | MANHOLES, CATCH BASINS, INLETS AND INSPECTION HOLES |
| P-150           | DEMOLITION  |
| P-151           | CLEARING AND GRUBBING                               |
| P-152           | EXCAVATION AND EMBANKMENT                           |
| P-153           | CONTROLLED LOW STRENGTH MATERIAL                    |
| P-610           | STRUCTURAL PORTLAND CEMENT CONCRETE                 |
| T-901           | SEEDING   |
| T-905           | TOPSOILING  |
| T-908           | MULCHING  |

**TABLE OF CONTENTS  
TECHNICAL SPECIFICATIONS**

**DIVISION 26 – ELECTRICAL**

| <u>SECTIONS</u> | <u>TITLE</u>                          |
|-----------------|---------------------------------------|
| 26_05_00        | COMMON WORK RESULTS FOR ELECTRICAL    |
| 26_05_18        | 600-VOLT OR LESS WIRES AND CABLES     |
| 26_05_21        | LOW VOLTAGE WIRE CONNECTIONS          |
| 26_05_26        | GROUNDING AND BONDING                 |
| 26_05_29        | HANGERS AND SUPPORTS                  |
| 26_05_33        | CONDUITS                              |
| 26_05_34        | BOXES                                 |
| 26_05_44        | DUCT BANKS                            |
| 26_05_53        | IDENTIFICATION FOR ELECTRICAL SYSTEMS |
| 26_08_50        | FIELD ELECTRICAL ACCEPTANCE TESTS     |
| 26_43_14        | SURGE PROTECTIVE DEVICES              |

**TABLE OF CONTENTS  
TECHNICAL SPECIFICATIONS**

**DIVISION 31 – EARTHWORK**

| <u>SECTIONS</u> | <u>TITLE</u>                                |
|-----------------|---|
| 31_05_19.14     | GEOTEXTILES                                 |
| 31_05_19.15     | GEOCOMPOSITE DRAINAGE NETS                  |
| 31_05_19.17     | FIBER REINFORCED POLYPROPYLENE (RPP) LINERS |

**TABLE OF CONTENTS  
TECHNICAL SPECIFICATIONS**

**DIVISION 35 – WATERWAY AND MARINE CONSTRUCTION**

| <u>SECTIONS</u> | <u>TITLE</u> |
|-----------------|--------------|
| 35_20_16.02     | SLIDE GATES  |

**TABLE OF CONTENTS  
TECHNICAL SPECIFICATIONS**

**DIVISION 40 – PROCESS INTEGRATION**

| <u>SECTIONS</u> | <u>TITLE</u>  |
|-----------------|---|
| 40_05_57.99     | ELECTROHYDRAULIC ACTUATOR   |
| 40_61_00        | COMMON WORK RESULTS FOR PROCESS CONTROL AND INSTRUMENTATION SYSTEMS |
| 40_61_15        | CONTROL STRATEGIES  |
| 40_67_01        | CONTROL SYSTEMS: PANELS, ENCLOSURES, AND PANEL COMPONENTS           |
| 40_80_01        | TESTING, CALIBRATION, AND COMMISSIONING                             |



# DIVISION 2 – AIRFIELD STANDARDS

Pond 001 Expansion

Construction Contract No.201737313

## Denver International Airport

Denver, Colorado

Sponsored By:

City & County of Denver Department of Aviation

Issued for Construction

November 21, 2017





## ITEM D-701 PIPE FOR STORM DRAINS AND CULVERTS

### DESCRIPTION

**701-1.1** This item shall consist of the construction of pipe culverts and storm drains in accordance with these specifications and in reasonably close conformity with the lines and grades shown on the plans.

### MATERIALS

**701-2.1** Materials shall meet the requirements shown on the plans and specified below.

**701-2.2 PIPE.** The pipe shall be of the type called for on the plans or in the proposal and shall be in accordance with the following appropriate requirements:

ASTM C76 Standard Specification for Reinforced Concrete Culvert, Storm Drain, and Sewer Pipe

AWWA C900 Polyvinyl Chloride (PVC) Pressure Pipe and Fabricated Fittings, 4 In. Through 12 In., for Water Transmission and Distribution

AWWA C905 Polyvinyl Chloride (PVC) Pressure Pipe and Fabricated Fittings, 14 In. Through 48 In., for Water Transmission and Distribution

AWWA C151 Ductile-Iron Pipe, Centrifugally Cast

**a. Concrete Pipe.** Concrete Pipe shall meet the requirements of ASTM C76, class III.

**b. PVC Pipe.** PVC pipe shall meet the requirements of AWWA C900 or C905. PVC pipe shall be pressure class 165 (DR 25).

**c. Ductile Iron Pipe.** Ductile iron pipe shall meet the requirements of AWWA C151. Ductile iron pipe shall be pressure class 350 and shall have an internal cement mortar lining and asphaltic seal coat in accordance with AWWA C104.

**701-2.3 CONCRETE.** Concrete for pipe cradles shall be in accordance with Item P-610.

**701-2.4 RUBBER GASKETS.** Rubber gaskets for rigid pipe shall conform to the requirements of ASTM C443 and shall be constructed from nitrile (Buna-N) rubber which is resistant to oil, jet fuel, and aircraft deicing fluids. Rubber gaskets for PVC pipe, polyethylene, and polypropylene pipe shall conform to the requirements of ASTM F477. Rubber gaskets for ductile iron pipe shall conform to the requirements of AWWA C111. Rubber gaskets for zinc-coated steel pipe and precoated galvanized pipe shall conform to the

requirements of ASTM D1056, for the “RE” closed cell grades. Rubber gaskets for steel reinforced thermoplastic ribbed pipe shall conform to the requirements of ASTM F477.

**701-2.5 JOINT MORTAR.** Pipe joint mortar shall consist of one part Portland cement and two parts sand. The Portland cement shall conform to the requirements of ASTM C150, Type I. The sand shall conform to the requirements of ASTM C144.

**701-2.6 JOINT FILLERS.** Poured filler for joints shall conform to the requirements of ASTM D6690.

**701-2.7 PLASTIC GASKETS.** Plastic gaskets shall conform to the requirements of AASHTO M198 (Type B).

**701-2.8 CONTROLLED LOW STRENGTH MATERIAL (CLSM).** Controlled low-strength material shall conform to the requirements of Item P-153. When CLSM is used all joints shall have gaskets.

**701-2.9 POLYETHYLENE FILM.** Polyethylene film for encasement of ductile iron pipe and fittings shall conform to AWWA C105 and shall be Class “C”-Black, with a minimum nominal thickness of 0.008-in. (8-mills). Tape for securing the film shall be thermoplastic material with a pressure sensitive adhesive face capable of bonding to metal, bituminous coating, and polyethylene. Tape shall have a minimum thickness of 8 mills and a minimum width of 1 in. the polyethylene film envelope shall be free as is commercially possible of gels, streaks, pinholes, particles of foreign matter, and undispersed raw materials. There shall be no other visible defect such as holes, tears, blisters, or thinning out at folds.

## CONSTRUCTION METHODS

**701-3.1 EXCAVATION.** The width of the pipe trench shall be sufficient to permit satisfactory jointing of the pipe and thorough tamping of the bedding material under and around the pipe, but it shall not be less than the external diameter of the pipe plus 6 inches (150 mm) on each side. The trench walls shall be approximately vertical.

The Contractor shall comply with all current Federal, state and local rules and regulations governing the safety of men and materials during the excavation, installation and backfilling operations. Specifically, the Contractor shall observe that all requirements of the Occupational Safety and Health Administration (OSHA) relating to excavations, trenching and shoring are strictly adhered to. The width of the trench shall be sufficient to permit satisfactorily jointing of the pipe and thorough compaction of the bedding material under the pipe and backfill material around the pipe, but it shall not be greater than the widths shown on the plans trench detail. The trench bottom shall be shaped to fully and uniformly support the bottom quadrant of the pipe.

Where rock, hardpan, or other unyielding material is encountered, the Contractor shall remove it from below the foundation grade for a depth of at least 8 inch (200 mm) or 1/2 inch (12 mm) for each foot of fill over the top of the pipe (whichever is greater) but for no more than three-quarters of the nominal diameter of the pipe. The excavation below grade shall be backfilled with selected fine compressible material, such as silty clay or loam, and lightly

compacted in layers not over 6 inches (150 mm) in uncompacted depth to form a uniform but yielding foundation.

Where a firm foundation is not encountered at the grade established, due to soft, spongy, or other unstable soil, the unstable soil shall be removed and replaced with approved granular material for the full trench width. The DEN Project Manager shall determine the depth of removal necessary. The granular material shall be compacted to provide adequate support for the pipe.

In the event of ground water invasion of the trench, the contractor shall be responsible for all dewatering work as subsidiary to the contract pay items. There will be no additional payment for pumping, dewatering wells, over excavation, etc. due to ground water.

The excavation for pipes placed in embankment fill shall not be made until the embankment has been completed to a height above the top of the pipe as shown on the plans.

**701-3.2 BEDDING.** The pipe bedding shall conform to the class specified on the plans. The bedding surface for the pipe shall provide a firm foundation of uniform density throughout the entire length of the pipe. When no bedding class is specified or detailed on the plans, the requirements for Class C bedding shall apply.

**a. Concrete Pipe.** Class A bedding shall consist of a continuous concrete cradle conforming to the plan details.

Class B bedding shall be in accordance with Item P-153, having a thickness of at least 6 inches (150 mm) below the bottom of the pipe and extending up around the pipe for a depth of not less than 30 percent of the pipe's vertical outside diameter. The layer of bedding material shall cover at least 10 percent of the pipe's vertical diameter. When CLSM is used, all joints shall have gaskets.

**b. Flexible Pipe.** For flexible pipe, the bedding material shall be in accordance with Item P-153.

**c. PVC and Ductile Iron pipe.** For PVC, polyethylene, and polypropylene pipe, the bedding material shall be in accordance with Item P-153. The bedding shall have a thickness of at least 6 inches (150 mm) below the bottom of the pipe and extend up around the pipe for a depth of not less than 50% of the pipe's vertical outside diameter.

**701-3.3 LAYING PIPE.** The pipe laying shall begin at the lowest point of the trench and proceed upgrade. The lower segment of the pipe shall be in contact with the bedding throughout its full length. Bell or groove ends of rigid pipes and outside circumferential laps of flexible pipes shall be placed facing upgrade.

Paved or partially lined pipe shall be placed so that the longitudinal center line of the paved segment coincides with the flow line.

Elliptical and elliptically reinforced concrete pipes shall be placed with the manufacturer's reference lines designating the top of the pipe within five degrees of a vertical plane through the longitudinal axis of the pipe.

**701-3.4 JOINING PIPE.** Joints shall be made with (1) Portland cement mortar, (2) Portland cement grout, (3) rubber gaskets, (4) plastic gaskets, or (5) coupling bands.

Mortar joints shall be made with an excess of mortar to form a continuous bead around the outside of the pipe and shall be finished smooth on the inside. Molds or runners shall be used for grouted joints to retain the poured grout. Rubber ring gaskets shall be installed to form a flexible watertight seal.

**a. Concrete Pipe.** Concrete pipe may be either bell and spigot or tongue and groove. Concrete pipe joints shall be sealed with rubber gaskets which conform to ASTM C443. The method of joining pipe sections shall be so the ends are fully entered and the inner surfaces are reasonably flush and even.

**b. PVC Pipe.** Joints for PVC pipe shall conform to the requirements of ASTM D3212 and shall be of the fully restrained type.

**c. Ductile Iron Pipe.** Ductile iron pipe joints which are buried in soil shall conform to the requirements of AWWA C111 and shall be of the push on or mechanical type. Joints located inside manholes shall be of the flanged or grooved type as shown on the plans. All joints shall be of the fully restrained type.

**701-3.5 POLYETHYLENE ENCASEMENT.** Buried ductile iron pipe and ductile iron fittings shall be encased with a double layer of polyethylene tube as specified in section 701-2.9. Polyethylene sheets conforming to the same requirements may be substituted for tube as fittings. Exposure to the weather shall be kept to a minimum and in no case shall it exceed 10 days.

**701-3.6 BACKFILLING.** Pipes shall be inspected before any backfill is placed; any pipes found to be out of alignment, unduly settled, or damaged shall be removed and relaid or replaced at the Contractor's expense.

Backfill material for 108" reinforced concrete pipe shall be fine, readily compatible soil or granular material selected from the excavation or a source of the Contractor's choosing. It shall not contain frozen lumps, stones that would be retained on a 2-inch (50 mm) sieve, chunks of highly plastic clay, or other objectionable material. Granular backfill material shall have 95% or more passing the a 1/2 inch (12 mm) sieve, with 95% or more being retained on the No. 4 (4.75 mm) sieve.

When the top of the pipe is even with or below the top of the trench, the backfill shall be compacted in layers not exceeding 6 inches (150 mm) on each side of the pipe and shall be brought up one foot (30 cm) above the top of the pipe or to natural ground level, whichever is greater. Thoroughly compact the backfill material under the haunches of the pipe without displacing the pipe. Material shall be brought up evenly on each side of the pipe for the full length of the pipe.

When the top of the pipe is above the top of the trench, the backfill shall be compacted in layers not exceeding 6 inches (150 mm) and shall be brought up evenly on each side of the pipe to one foot (30 cm) above the top of the pipe. The width of backfill on each side of the pipe for the portion above the top of the trench shall be equal to twice the pipe's diameter or 12 feet (3.7 m), whichever is less.

All backfill shall be compacted to the density required under Item P-152.

Material for backfill for all other pipes (other than 108" RCP) shall meet the requirements of P-153.

It shall be the Contractor's responsibility to protect installed pipes and culverts from damage due to construction equipment operations. The Contractor shall be responsible for installation of any extra strutting or backfill required to protect pipes from the construction equipment.

### **701-3.7 QUALITY ASSURANCE/QUALITY CONTROL**

#### **a. Qualifications.**

(1) **Pipe Manufacturer:** The Contractor shall submit verifiable information of satisfactory manufacturing experience for the past 5 years with design and fabrication of reinforced concrete pipe of similar size and design.

(2) **Installer:** Contractor shall submit verifiable information of satisfactory experience in the installation of reinforced concrete storm sewer pipe of similar size and extent, with a minimum of 5 years experience.

#### **b. Testing.** All pipe shall be certified by the pipe manufacturer.

(1) **Yard testing of Pipe for Certification.** Testing shall be performed in accordance with ASTM C 443 on a minimum of two (2) lengths of pipe and one (1) complete joint for every 500 linear feet of pipe, or less.

(2) **Testing of Installed Pipe.** ASTM C 1103 shall be followed to field test pipe joints. The test procedure shall be used for joint acceptance of all installed concrete pipe. All field joints shall be tested and certified before backfilling operations are allowed to begin.

Acceptance testing may involve hazardous materials, operations and equipment. These specifications do not address the safety problems associated with the testing procedures. It is the responsibility of the Contractor to establish appropriate safety and health practices.

(3) **Repair of Joints that Test as Unacceptable.** In the event of a reinforced concrete pipe joint failing the in-place pressure test, identified above, the Contractor shall repair the joint by injecting a chemical grout into the joint circumference.

The chemical grout shall be a non-flammable liquid which, when activated by water, forms a flexible closed-cell polyurethane foam. The chemical grout shall be resistant to petroleum products. The chemical grout shall be Flex LV or Flex 44, as applicable, manufactured by Deneef America, Inc., 122 North Mill Street, St. Louis, Michigan 48880-0034, or approved equal. Chemical grout shall be prepared, mixed, injected and cured in accordance with the manufacturer's recommendations.

The equipment used to inject the chemical grout shall be of construction similar to that of the pressure testing equipment. Chemical grout shall be injected into the joint at a minimum 40 psi to insure the grout penetrates through the leak to the outside of the joint.

After injecting the chemical grout, the injection valves shall be shut off to prevent backflow of the grout. The chemical grout shall have adequate time to cure prior to removal of the injection equipment. The joint shall be retested after repair in accordance with the pressure testing procedure described in these specifications.

(4) **Gasket Material Test.** Gaskets may be exposed to petroleum products. Gasket material shall be certified to have complied with ASTM C 443 and petroleum resistant characteristics of ASTM C 361.

(5) **Backfill Tests.** Refer to Section P-152, Part 6 for test and test frequency.

c. **Submittals.** The Contractor shall make the following submittals to the Project Manager for review and approval, or testing, as the case may be:

(1) **Pipe Design and Detail Drawings.** If the Contractor elects to use an alternate pipe, then the Contractor shall prepare or cause to be prepared, complete design calculations, plans, cross-sections, shop details for all pipe and accessories, and trench shoring/bracing system design for all trenches 20 feet in depth or greater. All final design calculations, plans, and shop drawings shall be sealed by a currently registered Professional DEN Project Manager in the State of Colorado whose disciplines is in the field of civil or structural engineering.

(2) **Qualifications.** Refer to 701-4.01, Item A.

(3) **Pipe Certification.** The Contractor shall submit the results and certifications for tested pipe made in the pipe manufacturer's shop (refer to Part 701-4.01, Item A1). The Contractor shall further provide certification of each spool piece of pipe as it is delivered to the job site.

This certification shall accompany the pipe bill of lading.

d. **Pipe Field Joint Test Certification.** The Contractor shall maintain records of all pipe joint tests. A copy of these test records shall be turned over to the Project Manager with a letter certifying that all joints under construction have been tested in accordance with the specifications for joint seal and integrity.

**e. Pipe Manufacturer’s QA/QC Program.** The manufacturer of reinforced concrete pipe shall have in place at all times an active Quality Assurance and Quality Control Program. A written copy of this program shall be on file in the manufacturer’s shop at all times. The Contractor shall submit copies of the QA/QC Program to the Project Manager for review and approval prior to the start of manufacture of pipe.

**f. Mill Test Certificates.** The pipe manufacturer to retain on file a copy of mill certification reports for the reinforcing steel and cement used in the manufacture of the concrete pipe. An appropriate number of copies of said certifications shall be submitted to the Project Manager.

**g. Pipe Gasket Certification Test.** The Contractor shall selectively test the “O” ring synthetic rubber gasket material at an approved independent testing laboratory. Certified results shall be submitted to the Project Manager for review and approval.

**h. Inspection.** All pipe shall be inspected at the yard prior to shipment, at the point of receipt and when placed in the trench prior to backfilling. The Project Manager shall inspect all pipe to be used for damage prior to installation. Pipe shall be inspected for damage and compliance to the manufacturer’s specifications and Contract Drawings. Units that are damaged shall be evaluated for the extent of damage. If, in the opinion of the Project Manager, damage is extensive enough to reduce the strength, durability, integrity, or ability to properly function with other parts of an installation (i.e. joint damage), the unit shall be rejected and the Contractor shall immediately remove the unit from the Project site. The Contractor may repair minor damage, if so authorized by the Project Manager, but at no cost to the City.

## METHOD OF MEASUREMENT

**701-4.1** The length of pipe shall be measured in linear feet (meter) of pipe in place, completed, and approved. It shall be measured along the centerline of the pipe from end or inside face of structure to the end or inside face of structure, whichever is applicable. The several classes, types and size shall be measured separately. All fittings with the exception of 108” RCP bends shall be included in the footage as typical pipe sections in the pipe being measured.

**701-4.2** 108” RCP bends shall be measured by the unit.

No separate measurement or payment shall be made for excavation and backfill, concrete encasement, connections to structures, RCP couplers, pipe bedding, or pipe inspections.

## BASIS OF PAYMENT

**701-5.1** Payment will be made at the contract unit price per linear foot (meter) for each kind of pipe of the type and size designated; inclusive of all pipe bedding, pipe cradles and required backfill. These prices shall fully compensate the Contractor for furnishing all materials and for all preparation, excavation, backfill, and installation of these materials; and for all labor, equipment, tools, and incidentals necessary to complete the item.



**701-5.2** The accepted quantity of 108” pipe bends will be paid for at the contract unit price per each in place when completed. This price shall fully compensate the Contractor for furnishing all materials and for all preparation, excavation, backfill, and installation of these materials; and for all labor, equipment, tools, and incidentals necessary to complete the item.

Payment will be made under:

|             |   |
|-------------|---|
| Item D-701a | Install 8” DIWF (C900 PVC) – per linear foot                      |
| Item D-701b | Install 12” DIW (C900 PVC) – per linear foot                      |
| Item D-701c | Install 12” SDG (Class III RCP) – per linear foot                 |
| Item D-701d | Install 12” FES (RCP) – per each                                  |
| Item D-701e | Install 16” DIW (C905 PVC)– per linear foot                       |
| Item D-701f | Install 16” Intake Pipe & Screen (Stainless Steel) – per lump sum |
| Item D-701g | Install 108” DIW (Class III RCP) – per linear foot                |
| Item D-701h | Install 108” DIW 45 Degree Bend – per each                        |
| Item D-701i | Install 6” Underdrain (Perforated PVC) – per linear foot          |
| Item D-701j | Install 12” Underdrain (Non-Perforated PVC) – per linear foot     |

### MATERIAL REQUIREMENTS

|             |   |
|-------------|---|
| AASHTO M198 | Standard Specification for Joints for Concrete Pipe, Manholes, and Precast Box Sections Using Preformed Flexible Joint Sealants |
| AASHTO M304 | Standard Specification for Poly (Vinyl Chloride) (PVC) Profile Wall Drain Pipe and Fittings Based on Controlled Inside Diameter |
| ASTM C76    | Standard Specification for Reinforced Concrete Culvert, Storm Drain, and Sewer Pipe   |
| ASTM C94    | Standard Specification for Ready Mixed Concrete   |
| ASTM C144   | Standard Specification for Aggregate for Masonry Mortar   |
| ASTM C150   | Standard Specification for Portland Cement  |
| ASTM C443   | Standard Specification for Joints for Concrete Pipe and Manholes, Using Rubber Gaskets  |
| ASTM D1056  | Standard Specification for Flexible Cellular Materials Sponge or Expanded Rubber  |
| ASTM D3034  | Standard Specification for Type PSM Poly (Vinyl Chloride) (PVC) Sewer Pipe and Fittings   |

- ASTM D3212      Standard Specification for Joints for Drain and Sewer Plastic Pipes  
Using Flexible Elastomeric Seals
- ASTM D6690      Standard Specification for Joint and Crack Sealants, Hot Applied, for  
Concrete and Asphalt Pavements
- ASTM F477      Standard Specification for Elastomeric Seals (Gaskets) for Joining  
Plastic Pipe

**END ITEM D-701**



## ITEM D-705 PIPE UNDERDRAINS FOR AIRPORTS

### DESCRIPTION

**705-1.1** This item shall consist of the construction of pipe drains in accordance with these specifications and in reasonably close conformity with the lines and grades shown on the plans.

### MATERIALS

**705-2.1 GENERAL.** Materials shall meet the requirements shown on the plans and specified below.

**705-2.2 PIPE.** The pipe shall be of the type called for on the plans or in the proposal and shall be in accordance with the following appropriate requirements.

ASTM F758 Standard Specification for Smooth-Wall Poly (Vinyl Chloride) (PVC) Plastic Underdrain Systems for Highway, Airport, and Similar Drainage

**705-2.3 JOINT MORTAR.** Pipe joint mortar shall consist of one part by volume Portland cement and two parts sand. The Portland cement shall conform to the requirements of ASTM C150, Type I. The sand shall conform to the requirements of ASTM C144. Hydrated lime may be added to the mixture of sand and cement in an amount equal to 15% of the weight of cement used. The hydrated lime shall meet the requirements of ASTM C206.

**705-2.4 ELASTOMERIC SEALS.** Elastomeric seals shall conform to the requirements of ASTM F477.

**705-2.5 POROUS BACKFILL.** Porous backfill shall be free of clay, humus, or other objectionable matter, and shall conform to the gradation in Table 1 when tested in accordance with ASTM C136.

**Table 1. Gradation Of Porous Backfill**

| Sieve Designation<br>(square openings) | Percentage by Weight<br>Passing Sieves |
|--|--|
|  | Porous Material No. *                  |
| 1-1/2 inch (38 mm)                     | *100                                   |
| 1 inch (25 mm)                         | *90-100                                |
| 3/8 inch (9 mm)                        | *25-60                                 |
| No. 4 (4.75 mm)                        | *5-40                                  |

|                   |       |
|-------------------|-------|
| No. 8 (2.36 mm)   | *0-20 |
| No. 16 (1.18 mm)  | *     |
| No. 50 (0.30 mm)  | *     |
| No. 100 (0.15 mm) | *     |

**705-2.6 GRANULAR MATERIAL.** Granular material used for backfilling shall conform to the requirements of ASTM D2321 for Class IA, IB, or II materials, or shall meet the requirements of AASHTO Standard Specification for Highway Bridges Section 30.

**705-2.7 FILTER FABRIC.** The filter fabric shall conform to the requirements of Item P-161.

**705-2.8 CONTROLLED LOW-STRENGTH MATERIAL (CLSM).** Controlled low-strength material shall conform to the requirements of Item P-153. When CLSM is used all joints shall have elastomeric seals.

**705-2.9 CONCRETE.** Concrete shall conform to the requirements of Item P-610.

**705-2.10 CASTINGS.** Metal frames and covers for cleanouts shall be gray iron castings conforming to the requirements of ASTM A48, Class 20 or shall be constructed from cast aluminum. Cleanout covers shall be designed to support 100,000 lb. aircraft wheel loads.

### CONSTRUCTION METHODS

**705-3.1 EQUIPMENT.** All equipment required for the construction of pipe underdrains shall be on the project, in good working condition, and approved by the DEN Project Manager before construction is permitted to start.

**705-3.2 EXCAVATION.** The width of the pipe trench shall be sufficient to permit satisfactory jointing of the pipe and thorough tamping of the bedding material under and around the pipe, but shall not be less than the external diameter of the pipe plus 6 inches (150 mm) on each side of the pipe. The trench walls shall be approximately vertical.

Where rock, hardpan, or other unyielding material is encountered, it shall be removed below the foundation grade for a depth of at least 4 inches (100 mm). The excavation below grade shall be backfilled with selected fine compressible material, such as silty clay or loam, and lightly compacted in layers not over 6 inches (150 mm) in uncompacted depth to form a uniform but yielding foundation.

Where a firm foundation is not encountered at the grade established, due to soft, spongy, or other unstable soil, the unstable soil shall be removed and replaced with approved granular material for the full trench width. The DEN Project Manager shall determine the depth of removal necessary. The granular material shall be compacted to provide adequate support for the pipe.

Excavated material not required or acceptable for backfill shall be disposed of by the Contractor as directed by the DEN Project Manager. The excavation shall not be carried below the required depth; if this occurs, the trench shall be backfilled at the Contractor's expense with material approved by the DEN Project Manager and compacted to the density of the surrounding material.

The pipe bed shall be shaped so at least the lower quarter of the pipe shall be in continuous contact with the bottom of the trench. Spaces for the pipe bell shall be excavated to allow the pipe barrel to support the entire weight of the pipe.

The Contractor shall do such trench bracing, sheathing, or shoring necessary to perform and protect the excavation as required for safety and conformance to Federal, state and local laws. Unless otherwise provided, the bracing, sheathing, or shoring shall be removed by the Contractor after the backfill has reached at least 12 inches (300 mm) over the top of the pipe. The sheathing or shoring shall be pulled as the granular backfill is placed and compacted to avoid any unfilled spaces between the trench wall and the backfill material. The cost of bracing, sheathing, or shoring, and the removal of same, shall be included in the unit price bid per foot (meter) for the pipe.

### **705-3.3 LAYING AND INSTALLING PIPE.**

**a. PVC or Polyethylene Pipe.** PVC or polyethylene pipe shall be installed in accordance with the requirements of ASTM D2321 or AASHTO Standard Specification for Highway Bridges Section 30. Perforations shall meet the requirements of AASHTO M252 or M294 Class 2, unless otherwise indicated on the plans. The pipe shall be laid accurately to line and grade.

**b. All Types of Pipe.** The upgrade end of pipelines, not terminating in a structure, shall be plugged or capped as approved by the DEN Project Manager.

Unless otherwise shown on the plans, a 4 inch (100 mm) bed of granular backfill material shall be spread in the bottom of the trench throughout the entire length under all perforated pipe underdrains.

Pipe outlets for the underdrains shall be constructed when required or shown on the plans. The pipe shall be laid with tight-fitting joints. Porous backfill is not required around or over pipe outlets for underdrains. All connections to other drainage pipes or structures shall be made as required and in a satisfactory manner. If connections are not made to other pipes or structures, the outlets shall be protected and constructed as shown on the plans.

**c. Filter Fabric.** The filter fabric shall be installed in accordance with the manufacturer's recommendations, or in accordance with AASHTO M288, unless otherwise shown on the plans.

**705-3.4 MORTAR.** The mortar shall be of the desired consistency for caulking and filling the joints of the pipe and for making connections to other pipes or to structures. Mortar that is not used within 45 minutes after water has been added shall be discarded. Retempering of mortar shall not be permitted.

### 705-3.5 BACKFILLING.

**a. Earth.** All trenches and excavations shall be backfilled soon after the pipes are installed, unless additional protection of the pipe is directed. The backfill material shall be select material from excavation or borrow and shall be approved by the DEN Project Manager. The select material shall be placed on each side of the pipe out to a distance of the nominal pipe diameter and one foot (30 cm) over the top of the pipe and shall be readily compacted. It shall not contain stones 3 inches (75 mm) or larger in size, frozen lumps, chunks of highly plastic clay, or any other material that is objectionable to the DEN Project Manager. The material shall be moistened or dried, as required to aid compaction. Placement of the backfill shall not cause displacement of the pipe. Thorough compaction under the haunches and along the sides to the top of the pipe shall be obtained.

The backfill shall be placed in loose layers not exceeding 6 inches (150 mm) in depth under and around the pipe, and not exceeding 8 inches (200 mm) over the pipe. Successive layers shall be added and thoroughly compacted by hand and pneumatic tampers, approved by the DEN Project Manager, until the trench is completely filled and brought to the planned elevation. Backfilling shall be done in a manner to avoid damaging top or side pressures on the pipe.

In embankments and other unpaved areas, the backfill shall be compacted per Item P-152 to the density required for embankments in unpaved areas. Under paved areas, the subgrade and any backfill shall be compacted per Item P-152 to the density required for embankments for paved areas.

**b. Granular Material.** When granular backfill is required, its placement in the trench and about the pipe shall be as shown on the plans. Special care shall be taken in placing the backfill. The granular backfill shall not contain a damaging amount of foreign matter, nor shall earth from the sides of the trench or from the windrow be allowed to filter into the backfill. When required by the DEN Project Manager, a template shall be used to properly place and keep separate the two sizes of backfill. The backfill shall be placed in loose layers not exceeding 6 in (150 mm) in depth and compacted by hand and pneumatic tampers to the requirements as given for earth backfill. Backfilling shall be done in a manner to avoid injurious top or side pressure on the pipe. The granular backfill shall be made to the elevation of the trench, as shown on the plans.

When perforated pipe is specified, granular backfill material shall be placed along the full length of the pipe. The position of the granular material shall be as shown on the plans. If the original material excavated from the trench is pervious and suitable, it shall be used in lieu of porous backfill No. 1.

If porous backfill is placed in paved or adjacent to paved areas before grading or subgrade operations is completed, the backfill material shall be placed immediately after laying the pipe. The depth of the granular backfill shall be not less than 12 inches (300 mm), measured from the top of the underdrain. During subsequent construction operations, a minimum depth of 12 inches (300 mm) of backfill shall be maintained over the underdrains. When the underdrains are to be completed, any unsuitable material shall be removed exposing the

porous backfill. Porous backfill containing objectionable material shall be removed and replaced with suitable material. The cost of removing and replacing any unsuitable material shall be at the Contractor's expense.

If a granular subbase blanket course is used which extends several feet beyond the edge of paving to the outside edge of the underdrain trench, the granular backfill material over the underdrains shall be placed in the trench up to an elevation of 2 inches (50 mm) above the bottom surface of the granular subbase blanket course. Immediately prior to the placing of the granular subbase blanket course, the Contractor shall blade this excess trench backfill from the top of the trench onto the adjacent subgrade where it can be incorporated into the granular subbase blanket course. Any unsuitable material that remains over the underdrain trench shall be removed and replaced. The subbase material shall be placed to provide clean contact between the subbase material and the underdrain granular backfill material for the full width of the underdrain trench.

**c. Controlled Low-Strength Material (CLSM).** Controlled low-strength material shall conform to the requirements of Item P-153.

**d. Deflection Testing.** The DEN Project Manager may at any time, notwithstanding previous material acceptance, reject or require re-installation of pipe that exceeds 5% deflection when measured in accordance with ASTM D2321, including Appendices.

**705-3.6 CONNECTIONS.** When the plans call for connections to existing or proposed pipe or structures, these connections shall be watertight and made to obtain a smooth uniform flow line throughout the drainage system.

**705-3.7 CLEANING AND RESTORATION OF SITE.** After the backfill is completed, the Contractor shall dispose of all surplus material, soil, and rubbish from the site. Surplus soil may be deposited in embankments, shoulders, or as directed by the DEN Project Manager. Except for paved areas of the airport, the Contractor shall restore all disturbed areas to their original condition.

## METHOD OF MEASUREMENT

**705-4.1** The length of pipe shall be the number of linear feet (meters) of pipe underdrains in place, completed, and approved; measured along the centerline of the pipe from end or inside face of structure to the end or inside face of structure, whichever is applicable. The several classes, types, and sizes shall be measured separately. All fittings shall be included in the footage as typical pipe sections in the pipeline being measured.

## BASIS OF PAYMENT

**705-5.1** Pipe underdrains, Complete. Pipe underdrains, complete (including porous backfill and filter fabric) shall be made at the contract unit price per linear foot (meter) COMPLETE (including porous backfill).



These prices shall be full compensation for furnishing all materials and for all preparation, excavation, and installation of these materials, and for all labor, equipment, tools, and incidentals necessary to complete the item.

Payment will be made under:

- |             |   |
|-------------|---|
| Item D-705a | Install 6” Underdrain (Perforated PVC) – per linear foot      |
| Item D-705b | Install 12” Underdrain (Non-Perforated PVC) – per linear foot |

### **MATERIAL REQUIREMENTS**

- |             |   |
|-------------|---|
| ASTM A48    | Standards Specification for Gray Iron Castings  |
| ASTM C136   | Standard Test Method for Sieve or Screen Analysis of Fine and Coarse Aggregates   |
| ASTM C144   | Standard Specification for Aggregate for Masonry Mortar   |
| ASTM C150   | Standard Specification for Portland Cement  |
| ASTM C206   | Standard Specification for Finishing Hydrated Lime  |
| ASTM D2321  | Standard Practice for Underground Installation of Thermoplastic Pipe for Sewers and Other Gravity-Flow Applications                     |
| ASTM D3034  | Standard Specification for Type PSM Poly(Vinyl Chloride) (PVC) Sewer Pipe and Fittings  |
| ASTM F477   | Standard Specification for Elastomeric Seals (Gaskets) for Joining Plastic Pipe   |
| ASTM F758   | Standard Specification for Smooth Wall Poly(Vinyl Chloride) (PVC) Plastic Underdrain Systems for Highway, Airport, and Similar Drainage |
| AASHTO M252 | Standard Specification for Corrugated Polyethylene Drainage Pipe  |
| AASHTO M288 | Standard Specification for Geotextile Specification for Highway Applications  |
| AASHTO M294 | Standard Specification for Corrugated Polyethylene Pipe, 300- to 1500- mm (12- to 60-in.) Diameter                                      |
| AASHTO      | Standard Specifications for Highway Bridges   |

**END OF ITEM D-705**

**ITEM D-710 ROCK RIPRAP**

**DESCRIPTION**

**710-1.1** This item shall consist of furnishing and placing of rock riprap as shown on the plans and called for in these specifications. Placing of riprap will include all bedding, fabric (if applicable), grout, and stones as indicated on the plans or as directed by the DEN Project Manager.

**MATERIALS**

**710-2.1 STONE.** All stone for rock riprap shall be sound, durable, and free from seams, cracks, and other defects and shall be as nearly rectangular as practicable. The stone shall have a specific gravity of at least 2.5. Broken concrete pieces obtained from the project may be used providing they meet the requirements contained herein.

**a. Classification and Gradation of Riprap:**

(1) Type “M”. Maximum size for Type "M" shall be 1 cubic foot with the maximum dimension 21 inches (53 cm). Minimum dimension shall be 4 inches (10 cm). The stone shall be well graded between 4 inches (10 cm) and 21 inches (53 cm). Gradation shall meet the requirements of Table 1 below.

**Table 1.**

| <b>Riprap Designation</b> | <b>% Smaller Than Given Size By Weight</b> | <b>Intermediate Rock Dimension Inches (cm)</b> | <b>d<sub>50</sub>* inches (cm)</b> |
|---------------------------|--|--|------------------------------------|
| Type M                    | 70-100                                     | 21 (53)  | 12 (30)                            |
|                           | 50-70                                      | 18 (46)  |                                    |
|                           | 35-50                                      | 12 (30)  |                                    |
|                           | 2-10                                       | 4 (10)   |                                    |

\*d<sub>50</sub> = Mean particle size

(2) Type “H”. Maximum size for Type "H" shall be 1 cubic foot (0.03 cubic meter) with the maximum dimension 30 inches (76 cm). Minimum dimension shall be 4 inches (10 cm). The stone shall be well graded between 6 inches (15 cm) and 30 inches (76 cm). Gradation shall meet the requirements of Table 2 below.

**Table 2.**

| <b>Riprap Designation</b> | <b>% Smaller Than Given Size By Weight</b> | <b>Intermediate Rock Dimension Inches (cm)</b> | <b>d<sub>50</sub>* inches (cm)</b> |
|---------------------------|--|--|------------------------------------|
| Type H                    | 100  | 30 (76)  | 18 (46)                            |
|                           | 50-70                                      | 24 (61)  |                                    |
|                           | 35-50                                      | 18 (46)  |                                    |
|                           | 2-10                                       | 6 (15)   |                                    |

\*d<sub>50</sub> = Mean particle size

(3) Type “VH”. Maximum size for Type "VH" shall be 1 cubic foot (0.03 cubic meter) with the maximum dimension 42 inches (107 cm). Minimum dimension shall be 9 inches (23 cm). The stone shall be well graded between 9 inches (23 cm) and 42 inches (107 cm). Gradation shall meet the requirements of Table 3 below.

**Table 3.**

| <b>Riprap Designation</b> | <b>% Smaller Than Given Size By Weight</b> | <b>Intermediate Rock Dimension Inches (cm)</b> | <b>d<sub>50</sub>* inches (cm)</b> |
|---------------------------|--|--|------------------------------------|
| Type VH                   | 100  | 42 (107)                                       | 24 (61)                            |
|                           | 50-70                                      | 33 (84)  |                                    |
|                           | 35-50                                      | 24 (61)  |                                    |
|                           | 2-10                                       | 9 (23)   |                                    |

\*d<sub>50</sub> = Mean particle size

(4) Type “L”. Maximum size for Type “L” shall be 1 cubic foot (0.03 cubic meter) with the maximum dimension 15 inches (38 cm). Minimum dimension shall be 3 inches (8 cm). The stone shall be well graded between 3 inches (8 cm) and 15 inches (38 cm). Gradation shall meet the requirements of Table 4 below.

**Table 4.**

| <b>Riprap Designation</b> | <b>% Smaller Than Given Size By Weight</b> | <b>Intermediate Rock Dimension Inches (cm)</b> | <b>d<sub>50</sub>* inches (cm)</b> |
|---------------------------|--|--|------------------------------------|
| Type L                    | 70-100                                     | 15 (38)  | 9 (23)                             |
|                           | 50-70                                      | 12 (30)  |                                    |
|                           | 35-50                                      | 9 (23)   |                                    |
|                           | 2-10                                       | 3 (8)  |                                    |

\*d<sub>50</sub> = Mean particle size

Broken concrete pieces may be used in lieu of natural rock provided the dimensional requirements above are met, the pieces are sound and durable, and the material is approved by the DEN Project Manager prior to placing.

The nominal thickness of the completed riprap section, regardless of the type specified, shall be 1.5 times the mean diameter of the rock specified in Tables 1, 2, 3 and/or 4 of this specification.

**710-2.2 BEDDING MATERIAL.** The free draining material shall consist of a Colorado Department of Transportation (CDOT) Specification; Class B or Class C filter material, reference Table 5 below. Type L riprap shall use CDOT Class A bedding material, referenced in Table 5 below.

**Table 5. Gradation Specifications for Filter Material**

| Sieve Size       | Mass Percent Passing square Mesh Sieves |         |         |
|------------------|---|---------|---------|
|                  | Class A                                 | Class B | Class C |
| 75 mm (3")       | 100                                     |         |         |
| 37.5 mm (1 ½")   |   | 100     |         |
| 19.0 mm (¾")     | 20-90                                   |         | 100     |
| 4.75 mm (No. 4)  | 0-20                                    | 20-60   | 60-100  |
| 1.8 µm (No.16)   |   | 10-30   |         |
| 300 µm (No. 50)  |   | 0-10    | 10-30   |
| 150 µm (No. 100) |   |         | 0-10    |
| 75 µm (No. 200)  | 0-3                                     | 0-3     | 0-3     |

**710-2.3 FILTER FABRIC.** The filter fabric material to be placed under the non-grouted rock riprap shall be a non-woven polypropylene fabric having the following properties:

- a. Weight 8 ounces/square yard (271 grams/square meter)
- b. Tensile strength, wet Warp direction – 200 pounds (90 kg)
- c. Fill direction 275 pounds (125 kg)
- d. Mullen Burst (ASTM D 751) 400 psi (3 MPa)
- e. Elongation-at-break 75 percent

**710-2.4 CEMENT GROUT.** Grout shall be composed of 560 pounds cement per cubic yard (332 kg/cubic meter) conforming to the requirements of ASTM C 150 Type I/II,

70 percent fine aggregate conforming to the requirements of ASTM C 33, and 30 percent No. 8 coarse aggregate conforming to the requirements of ASTM C 33, Class 4S.

The grout shall have an air content of 6 – 9% when tested in accordance with ASTM C 231, a slump of 5 – 9 inches (13-23 cm) when tested in accordance with ASTM C 143, and a minimum 28-day compressive strength of 2000 psi (13.7 MPa) when sampled in accordance with ASTM C 31 and tested in accordance with ASTM C 39.

**710-2.5 TESTING LABORATORY.** The laboratory used to develop the grout mix design shall meet the requirements of ASTM C 1077 including accreditation. Accreditation shall include all test procedures required to develop the mix design. A certification signed by the manager of the laboratory stating it meets these requirements shall be submitted to the DEN Project Manager. The certification shall contain as a minimum:

- a. Qualifications of personnel; including the laboratory manager, supervising technician, and testing technicians involved in developing the mix design.
- b. Evidence of accreditation by a nationally recognized laboratory accreditation organization for all test methods used in developing the mix design.

**710-2.6 SUBMITTALS.** Contractor shall submit certification that the product delivered to the project site will have values equal to or greater than those specified above.

- a. Stone – Certification of Compliance detailing gradation and specific gravity.
- b. Bedding Material – Certification of Compliance showing gradation.
- c. Filter Fabric – Certification of Compliance.
- d. Grout – The Contractor shall submit a mix design including all proposed materials to the DEN Project Manager for the Grout at least thirty (30) days prior to use. The mix design and materials will not be approved when the laboratory trial mix is older than two (2) years and the Certificates of Compliance for the materials are the results from tests performed more than one (1) year in the past.

## CONSTRUCTION METHODS

**710-3.1 EXCAVATION.** The slopes shall be finished to a reasonably smooth and compact surface within 2 inches (5 cm) of the lines, surfaces, and elevations shown on the plans.

**710-3.2 ROCK RIPRAP.** The filter fabric shall be spread on the prepared subgrade to provide a continuous, smooth, surface. After placing bedding material, the stone shall be spread on the filter fabric so as to produce a compact, well graded mass of minimum voids. Spreading shall be done so as to cause as little disturbance to the filter fabric as possible. Some rearranging of individual pieces may be required, either by hand or equipment, to obtain a reasonably uniform surface.

**710-3.3 GROUTED RIPRAP.** When grouted riprap is specified, the stone shall be laid as set forth above for rock riprap, except that filter fabric is not required. The spaces between the stones shall then be filled with grout. Sufficient grout shall be used to completely fill all voids, except that the face surface of the stone shall be left exposed. After grouting is completed, the surface shall be cured for a period of at least three days.

**710-3.4 BATCH TICKETS.** A sample copy of the proposed batch ticket shall be submitted to the DEN Project Manager for approval. Two copies of the batch ticket shall also be provided to the DEN Project Manager or his representative for each batch of concrete prior to unloading at the site. Grout delivered without a batch ticket containing complete information as specified shall be rejected. The Contractor shall collect and complete the batch ticket at the placement site and deliver all batch tickets to the DEN Project Manager's representative on a daily basis. The DEN Project Manager shall have access to the batch tickets at any time during the placement. The following information shall be provided on each batch ticket:

- a. Supplier's name and date
- b. Truck number
- c. Project number and location
- d. Cubic yards batched
- e. Time batched
- f. Mix design number
- g. Type, brand, and amount of each admixture
- h. Type, brand, and amount of cement
- i. Weights of fine and coarse aggregate
- j. Moisture of fine and coarse aggregate
- k. Gallons of batch water (including ice)
- l. Water cement ration
- m. Amount of water that can be added to the load prior to placement

The Contractor shall add the following information to the batch ticket at the placement site:

- n. Gallons of water added by truck operator plus quantity of concrete in each truck each time water is added.
- o. Number of revolutions of drum at mixing speed (for truck mixed concrete)

- p. Discharge time
- q. Location of batch in placement.

**710-3.5 MIXING CONDITIONS.** The grout shall be mixed only in quantities required for immediate use. Grout shall not be mixed while the air temperature is below 40°F (4°C) without permission of the DEN Project Manager. If permission is granted for mixing under such conditions, aggregates or water, or both, shall be heated and the grout shall be placed at a temperature not less than 50°F (10°C) nor more than 90°F (32°C). The Contractor shall be held responsible for any defective work, resulting from freezing or injury in any manner during placing and curing, and shall replace such work at his/her expense.

If the slump or air content of the load is below the specified amount at the time of arrival, the load can be adjusted prior to placement at the approval of the Contractor's Superintendent or authorized agent. Additional mixing shall be required as specified in ASTM C 94. Once placement has begun, no further adjustment shall be made. When additional water is added to the load the design water cement ratio shall not be exceeded. The amount of water that can be added to the load shall also be included on the batch ticket. Retempering of grout by adding water or any other material shall not be permitted.

The delivery of grout to the job shall be in such a manner that batches of grout will be deposited at uninterrupted intervals after placement has begun.

**710-3.6 ACCEPTANCE SAMPLING AND TESTING.** Grout will be accepted on the basis of the compressive strength specified in paragraph 2.4. The grout shall be sampled at the point of placement in accordance with ASTM C 172. Concrete cylindrical test specimens shall be made in accordance with ASTM C 31 and tested in accordance with ASTM C 39. Concrete strengths for acceptance shall be the average of at least two 6 by 12 in. (15 by 30 cm) or at least three 4 by 8 in. (10 by 20 cm) cylinders tested at 28 days. The grout shall be sampled every fifty cubic yards (38 cubic meters), or fraction thereof, per day. The contractor shall provide a suitable area or container at the project site for initial storage and curing (up to the first 48 hours after molding) of specimens cast for acceptance purposes. The container shall be capable of maintaining a temperature range of 60 to 80°F (16 to 27°C). The DEN Project Manager's Quality Assurance Laboratory will make the actual tests on the specimens at no expense to the Contractor.

## METHOD OF MEASUREMENT

**710-4.1** Type "M" rock riprap grouted shall be measured by the square yard, to the dimensions of the riprap as shown on the plans or as directed by the DEN Project Manager. Excavation, bedding, geotextile fabric, and grout are included in the contract unit price for Type "M" riprap and no separate measurement of payment will be made for them.

## BASIS OF PAYMENT

**710-5.1** The accepted quantity of Type “M” grouted rock riprap will be paid for at the contract unit price per square yard. The price shall be full compensation for furnishing and placing all material and for all labor, equipment, tools, and incidentals necessary to complete the work prescribed in this item.

Item D-710a Grouted Type M Riprap – Per Square Yard

#### **TESTING REQUIREMENTS**

|            |  |
|------------|--|
| ASTM C 31  | Making and Curing Test Specimens in the Field                |
| ASTM C 39  | Compressive Strength of Cylindrical Concrete Specimens       |
| ASTM C 138 | Unit Weight, Yield, and Air Content of Concrete              |
| ASTM C 143 | Slump of Hydraulic Cement Concrete                           |
| ASTM C 172 | Practice for Sampling Freshly Mixed Concrete.                |
| ASTM C 231 | Air Content of Freshly Mixed Concrete by the Pressure Method |

#### **MATERIAL REQUIREMENTS**

|            |  |
|------------|--|
| ASTM C 33  | Concrete Aggregates                    |
| ASTM C 94  | Ready Mixed Concrete                   |
| ASTM C 150 | Portland Cement                        |
| ASTM C 260 | Air Entraining Admixtures for Concrete |
| ASTM D 751 | Coated Fabric                          |

**END OF ITEM D-710**





## ITEM D-751 MANHOLES, CATCH BASINS, INLETS AND INSPECTION HOLES

### DESCRIPTION

**751-1.1** This item shall consist of construction of manholes, catch basins, inlets, and inspection holes, in accordance with these specifications, at the specified locations and conforming to the lines, grades, and dimensions shown on the plans or required by the DEN Project Manager.

### MATERIALS

**751-2.1 MORTAR.** Mortar shall consist of one part Portland cement and two parts sand. The Portland cement shall conform to the requirements of ASTM C150, Type I. The sand shall conform to the requirements of ASTM C144.

**751-2.2 CONCRETE.** Plain and reinforced concrete used in structures, connections of pipes with structures, and the support of structures or frames shall conform to the requirements of Item P-610.

**751-2.3 PRECAST CONCRETE PIPE MANHOLE RINGS.** Precast concrete pipe manhole rings shall conform to the requirements of ASTM C478. Unless otherwise specified, the risers and offset cone sections shall have an inside diameter of not less than 36 inches (90 cm) nor more than 48 inches (120 cm). There shall be a gasket between individual sections and sections cemented together with mortar on the inside of the manhole.

**751-2.4 FRAMES, COVERS, AND GRATES.** The castings shall conform to one of the following requirements:

- a. ASTM A48, Class 35B: Gray iron castings
- b. ASTM A47: Malleable iron castings
- c. ASTM A27: Steel castings
- d. ASTM A283, Grade D: Structural steel for grates and frames
- e. ASTM A536, Grade 65-45-12: Ductile iron castings
- f. ASTM A897: Austempered ductile iron castings

All castings or structural steel units shall conform to the dimensions shown on the plans and shall be designed to support the loadings, aircraft gear configuration and/or direct loading, specified.

Each frame and cover or grate unit shall be provided with fastening members to prevent it from being dislodged by traffic but which will allow easy removal for access to the structure.

All castings shall be thoroughly cleaned. After fabrication, structural steel units shall be galvanized to meet the requirements of ASTM A123.

**751-2.5 STEPS.** The steps or ladder bars shall be gray or malleable cast iron or galvanized steel. The steps shall be the size, length, and shape shown on the plans and those steps that are not galvanized shall be given a coat of bituminous paint, when directed.

**751-2.6 PRECAST INLET STRUCTURES.** Manufactured in accordance with and conforming to ASTM C1433.

**751-2.7 REINFORCING STEEL.** All reinforcing steel shall conform to ASTM A615, Grade 60.

**751-2.8 EPOXY LINING SYSTEM**

**a.** Characteristics:

- (1) 100 percent solids, plural component epoxy, capable of spray or roller application.
- (2) System capable of application to damp concrete surfaces in high relative humidity environment.
- (3) Resistant to attack from hydrogen sulfide and sulfuric acids generated from microbiological sources.
- (4) System shall meet requirements of ASTM C722 and ASTM D1763, and be 100 percent solids epoxy resin. A minimum finish thickness of 125 mils is required.

**b.** Properties:

- (1) Bond Strength, ASTM C478: Concrete failure.
- (2) Tensile Strength, ASTM C307: 2,500 psi, minimum.
- (3) Flexural Strength, ASTM C580: 4,800 psi.
- (4) Moisture Absorption, ASTM C413: 0.1 percent.
- (5) Shrinkage, ASTM C631: 0.11 percent, maximum.

**c.** Manufacturers and Products: No alternatives to the listed manufacturer's and products will be accepted.

| <b>Manufacturers</b>         | <b>Products</b>   |
|------------------------------|---|
| Environmental Coatings, Inc. | Sewer-Shield 100 (Trowel)<br>Sewer-Shield 101S (Spray)<br>Sewer-Shield 101A<br>Sewer-Shield 150 |
| Sauereisen, Inc.             | SewerGard 210X Epoxy  |
| Warren Environmental, Inc.   | S-301 Epoxy   |

## CONSTRUCTION METHODS

### 751-3.1 UNCLASSIFIED EXCAVATION.

**a.** The Contractor shall excavate for structures and footings to the lines and grades or elevations, shown on the plans, or as staked by the DEN Project Manager. The excavation shall be of sufficient size to permit the placing of the full width and length of the structure or structure footings shown. The elevations of the bottoms of footings, as shown on the plans, shall be considered as approximately only; and the DEN Project Manager may direct, in writing, changes in dimensions or elevations of footings necessary for a satisfactory foundation.

**b.** Boulders, logs, or any other objectionable material encountered in excavation shall be removed. All rock or other hard foundation material shall be cleaned of all loose material and cut to a firm surface either level, stepped, or serrated, as directed by the DEN Project Manager. All seams or crevices shall be cleaned out and grouted. All loose and disintegrated rock and thin strata shall be removed. Where concrete will rest on a surface other than rock, the bottom of the excavation shall not be disturb and excavation to final grade shall not be made until immediately before the concrete or reinforcing is placed.

**c.** The Contractor shall do all bracing, sheathing, or shoring necessary to implement and protect the excavation and the structure as required for safety or conformance to governing laws. The cost of bracing, sheathing, or shoring shall be included in the unit price bid for the structure.

**d.** All bracing, sheathing, or shoring involved in the construction of this item shall be removed by the Contractor after the completion of the structure. Removal shall not disturb or damage finished masonry. The cost of removal shall be included in the unit price bid for the structure.

**e.** After excavation is completed for each structure, the Contractor shall notify the DEN Project Manager. No concrete or reinforcing steel shall be placed until the DEN Project Manager has approved the depth of the excavation and the character of the foundation material.

**751-3.2 CONCRETE STRUCTURES.** Concrete structures shall be built on prepared foundations, conforming to the dimensions and shape indicated on the plans. When claystone

(undisturbed natural or fill) is encountered in the base of the excavation within paved areas as determined by the DEN Project Manager, the material shall be over-excavated to a depth of 3 feet below and 3 feet beyond the sides of the base of the structure. The over-excavation shall be replaced with Select Embankment material meeting the requirements for Item P-152. The Select Embankment material shall be placed in 8 inch thick loose lifts, moisture conditioned and compacted to the requirements of Item P-152. The construction shall conform to the requirements specified in Item P-610. Any reinforcement required shall be placed as indicated on the plans and shall be approved by the DEN Project Manager before the concrete is placed.

All invert channels shall be constructed and shaped accurately to be smooth, uniform, and cause minimum resistance to flowing water. The interior bottom shall be sloped to the outlet.

**751-3.3 PRECAST CONCRETE PIPE STRUCTURES.** Precast concrete structures shall conform to ASTM C478. Precast concrete structures shall be constructed on prepared or previously placed slab foundations conforming to the dimensions and locations shown on the plans. All precast concrete sections necessary to build a completed structure shall be furnished. The different sections shall fit together readily. Joints between precast concrete risers and tops shall be full-bedded in cement mortar and shall be smoothed to a uniform surface on both interior and exterior of the structure. The top of the upper precast concrete section shall be suitably formed and dimensioned to receive the metal frame and cover or grate, or other cap, as required. Provision shall be made for any connections for lateral pipe, including drops and leads that may be installed in the structure. The flow lines shall be smooth, uniform, and cause minimum resistance to flow. The metal steps that are embedded or built into the side walls shall be aligned and placed at vertical intervals of 12 inches (300 mm). When a metal ladder replaces the steps, it shall be securely fastened into position.

When required by the DEN Project Manager, the precast manufacturer shall provide detailed structural analysis of the structure being provided that considers the live and dead loads exposed to the structure. The analysis shall be signed and sealed by an engineer registered in the state of installation normally performing structural engineering.

**751-3.4 INLET AND OUTLET PIPES.** Inlet and outlet pipes shall extend through the walls of the structures a sufficient distance beyond the outside surface to allow for connections. They shall be cut off flush with the wall on the inside surface of the structure, unless otherwise directed. For concrete or brick structures, mortar shall be placed around these pipes to form a tight, neat connection.

**751-3.5 PLACEMENT AND TREATMENT OF CASTINGS, FRAMES, AND FITTINGS.** All castings, frames, and fittings shall be placed in the positions indicated on the plans or as directed by the DEN Project Manager, and shall be set true to line and elevation. If frames or fittings are to be set in concrete or cement mortar, all anchors or bolts shall be in place before the concrete or mortar is placed. The unit shall not be disturbed until the mortar or concrete has set.

When frames or fittings are placed on previously constructed masonry, the bearing surface of the masonry shall be brought true to line and grade and shall present an even bearing surface

so the entire face or back of the unit will come in contact with the masonry. The unit shall be set in mortar beds and anchored to the masonry as indicated on the plans or as directed by the DEN Project Manager. All units shall set firm and secure.

After the frames or fittings have been set in final position, the concrete or mortar shall be allowed to harden for seven (7) days before the grates or covers are placed and fastened down.

**751-3.6 INSTALLATION OF STEPS.** The steps shall be installed as indicated on the plans or as directed by the DEN Project Manager. When the steps are to be set in concrete, they shall be placed and secured in position before the concrete is placed. When the steps are installed in brick masonry, they shall be placed as the masonry is being built. The steps shall not be disturbed or used until the concrete or mortar has hardened for at least seven (7) days. After seven (7) days, the steps shall be cleaned and painted, unless they have been galvanized.

When steps are required with precast concrete structures, they shall be cast into the side of the sections at the time the sections are manufactured or set in place after the structure is erected by drilling holes in the concrete and cementing the steps in place.

When steps are required with corrugated metal structures, they shall be welded into aligned position at a vertical spacing of 12 inches (300 mm).

Instead of steps, prefabricated ladders may be installed. For concrete structures, the ladder shall be held in place by grouting the supports in drilled holes.

**751-3.7 BACKFILLING.**

**a.** After a structure has been completed, the area around it shall be backfilled with approved material, in horizontal layers not to exceed 8 inches (200 mm) in loose depth, and compacted to the density required in Item P-152. Each layer shall be deposited evenly around the structure to approximately the same elevation. The top of the fill shall meet the elevation shown on the plans or as directed by the DEN Project Manager.

**b.** Backfilling shall not be placed against any structure until approved by the DEN Project Manager. For concrete structures, approval shall not be given until the concrete has been in place seven (7) days, or until tests establish that the concrete has attained 75% of the design strength to withstand any pressure created by the backfill and placing methods.

**c.** Backfill shall not be measured for direct payment. Performance of this work shall be considered an obligation of the Contractor covered under the contract unit price for the structure involved.

**751-3.8 EPOXY LINING SYSTEM.** Where indicated in plans, apply epoxy liner to all walls, underside of top slab, and bottom of manhole. Do not apply epoxy to valves, fittings, and pipes located inside manholes.

**a. General.**

- (1) DEN Project Manager will inspect all cleaned manholes before application of lining system; provide 24-hour notification.
- (2) Apply or install system in accordance with the manufacturer's recommendations.
- (3) Upon completion of work, DEN Project Manager will inspect all lined manholes and be present for testing.
- (4) Apply Epoxy Lining System per the manufacturer's recommendations. A minimum finish thickness of 125 mils is required.

**b. Surface Preparation.** Prepare surface in accordance with manufacturer's recommendations using high pressure water blasting or other methods required to produce a clean surface that is acceptable to the epoxy liner material manufacturer and DEN Project Manager.

**c. Testing.**

- (1) Wet Film Thickness Gauge: During application, use wet film thickness gauge; meet ASTM D4414 to ensure monolithic coating and uniform thickness.
- (2) Holiday Detection:
  - (a) In accordance with NACE SPO 188.
  - (b) After 24 hours minimum and 72 hours maximum, spark test lining system to ensure pinhole-free lining.
  - (c) Mark defects and repaired per manufacturer's instructions.
  - (d) Voltage to be set at 100 volts per mil of epoxy thickness.
  - (e) After identification of pinholes, thin areas, and other imperfections, re-apply epoxy material and retest.
- (3) Adhesion Test:
  - (a) Test 10 percent minimum of manholes for adhesion/bond of coating to substrate. DEN Project Manager or designated representative will select manholes to be tested.
  - (b) Conduct in accordance with ASTM D4542 as modified herein.
    - i) Prepare coating and dollies to receive adhesive.

- ii) Complete within 24 hours minimum and 72 hours maximum of curing.
- iii) Attach three 20-millimeter dollies minimum. Adhesive used to attach dollies to coating shall be rapid setting with tensile strength in excess of coating product and permitted to cure in accordance with manufacturer's recommendations.
- iv) Failure of dolly adhesive shall be deemed a nontest and require retesting.
- v) Prior to performing pull test, score coating to within 30 mils of substrate by mechanical means without disturbing dolly or bond within test area.
- vi) Two (2) of the three (3) adhesion pulls shall exceed 200 psi or concrete failure with more than 80 percent of subsurface adhered to coating.
- vii) Should a structure fail to achieve two successful pulls as described above, perform additional testing at discretion of DEN Project Manager.
- viii) Areas detected to have inadequate bond strength shall be evaluated by DEN Project Manager or designated representative.
- ix) Further bond tests may be performed in area to determine extent of potentially deficient bonded area.
- x) Repair deficient areas.

**751-3.9 CLEANING AND RESTORATION OF SITE.** After the backfill is completed, the Contractor shall dispose of all surplus material, dirt, and rubbish from the site. Surplus dirt may be deposited in embankments, shoulders, or as approved by the DEN Project Manager. The Contractor shall restore all disturbed areas to their original condition. The Contractor shall remove all tools and equipment, leaving the entire site free, clear, and in good condition.

**751-3.10 QUALITY ASSURANCE/QUALITY CONTROL**

**a. Qualifications.** The Contractor shall meet the same qualifications for precast pipe structures as are identified in Item D-701 and shall impose all qualifications on its pipe manufacturer. Should the Contractor elect to cast-in-place junction structures, the Contractor shall be able to demonstrate experience with similar structures.



**b. Tests.** Tests for precast concrete pipe structures (including pipe joints) shall have imposed the same tests as for precast pipe in Item D-701. Refer to Item P-610 for cast-in-place concrete test requirements. All backfill material shall be tested for compaction in accordance with Items D-701 and P-152.

**c. Inspections.** Inspection for precast concrete pipe structures shall follow inspection procedures identified in Item D-701 for precast pipe and those of Item P-152 for excavation. Inspection for cast-in-place concrete structures shall follow Item P-610.

**d. Submittals.**

**(1) Materials.** Materials shall be submitted in accordance with Items P-610 and D-701.

**(2) Designs and Drawings.** If the Contractor elects to use an alternative pipe, then the Contractor shall design or cause the pipe manufacturer to design all precast pipe structures to the specified criteria. The Contractor shall submit support calculations, installation drawings, and detail drawings for review and approval by the Project Manager prior to proceeding with fabrication of structures. Calculations, drawings, and details shall be sealed and signed by a Professional Engineer currently registered in the State of Colorado.

Should the Contractor elect to substitute and construct precast and/or cast-in-place concrete structures, the Contractor shall submit full designs and details, as above, sealed and signed by a Professional Engineer currently registered in the State of Colorado.

### METHOD OF MEASUREMENT

**751-4.1** Manholes, catch basins, inlets, and inspection holes shall be measured by the unit.

### BASIS OF PAYMENT

**751-5.1** The accepted quantities of manholes, catch basins, inlets, and inspection holes will be paid for at the contract unit price per each in place when completed. This price shall be full compensation for furnishing all materials and for all preparation, excavation, backfilling and placing of the materials; furnishing and installation of such specials and connections to pipes and other structures as may be required to complete the item as shown on the plans; and for all labor equipment, tools and incidentals necessary to complete the structure.

Payment will be made under:

|             |  |
|-------------|--|
| Item D-751a | Modify Existing Diversion Structure – per lump sum                 |
| Item D-751b | Install DIW Manhole 6’ Diameter with 16” plug valve – per each     |
| Item D-751c | Install DIW Manhole 6’ Diameter with 2 - 8” plug valves – per each |

- Item D-751d Install DIW Manhole 5' Diameter – per each  
Item D-751e Install 108" Headwall & Wingwalls (108" Outfall) – per lump sum

### **MATERIAL REQUIREMENT**

- ASTM A27 Standard Specification for Steel Castings, Carbon, for General Application  
ASTM A47 Standard Specification for Ferritic Malleable Iron Castings  
ASTM A48 Standard Specification for Gray Iron Castings  
ASTM A123 Standard Specification for Zinc (Hot-Dip Galvanized) Coatings on Iron and Steel Products  
ASTM A283 Standard Specification for Low and Intermediate Tensile Strength Carbon Steel Plates  
ASTM A536 Standard Specification for Ductile Iron Castings  
ASTM A615 Standard Specification for Deformed and Plain Carbon-Steel Bars for Concrete Reinforcement  
ASTM A897 Standard Specification for Austempered Ductile Iron Castings  
ASTM C144 Standard Specification for Aggregate for Masonry Mortar  
ASTM C150 Standard Specification for Portland Cement  
ASTM C478 Standard Specification for Precast Reinforced Concrete Manhole Sections  
ASTM C1433 Standard Specification for Precast Reinforced Concrete Monolithic Box Sections for Culverts, Storm Drains, and Sewers

**END OF ITEM D-751**



## ITEM P-150 DEMOLITION DESCRIPTION

**150-1.1** This item shall consist of removal of existing gravel roadway, DIW pipes, DIW manholes, SDG pipes. The Contractor shall dispose of the material at a licensed disposal site or as directed by the DEN Project Manager. Material salvaged shall become the property of the Contractor.

The Contractor shall notify all utility, oil, and gas facility owners and the DEN Project Manager in writing 30 days in advance of requiring work in areas currently occupied by oil and gas wells and buried pipelines.

**150-1.2 WASTE DISPOSAL.** All removed asphalt and concrete pavements shall be delivered to the recycle yard in accordance with Section 01 74 19 Construction Waste Management. All other demolished materials shall be considered waste and disposed offsite at facilities approved for waste materials, unless specified otherwise.

## MATERIALS

**150-2.1 EQUIPMENT.** Excavation and Hauling Equipment: Provide equipment as necessary to remove underground pipelines and other demolished items.

## CONSTRUCTION METHODS

**150-3.1 GENERAL.** Blasting will not be allowed on this project.

**150-3.2 BURIED PIPELINE AND STORM SEWERS.**

**a. Trenching.** The removal of cover on top of and surrounding the abandoned pipelines shall be performed without damaging the pipeline. All trench sidewalls shall be properly sloped or benched and/or braced, shored or sheeted to afford safe working conditions, to protect adjacent pipelines, and to prevent caving.

**b. Testing.** The Contractor shall test the exposed trench excavation and the pipeline for dangerous or explosive gases and to positively determine that the line has been emptied, cleaned and/or purged prior to performing any further operations.

**c. Cutting of Pipeline and Storm Sewers.** Extreme care shall be exercised whenever the pipeline or storm sewer to be removed is cut into, especially the first cut on the abandoned pipeline. The Contractor shall use a method to cut the pipeline into

sections for removal which provides safety for workers and equipment. The initial cut shall not be made with a cutting torch.

(1) **BACKFILLING.** If required, select embankment (1" maximum size), per Technical Specification P-152 Excavation and Embankment, or P-153 Controlled Low-Strength Material, to 12 inches (305 mm) over the top of the pipe shall be completed before backfilling operations are started.

The Contractor shall take all necessary precautions to protect the pipe from any damage, movement or shifting. In general, backfilling shall be performed by pushing the material from the end of the trench into, along and directly over the pipe so that the material will be applied in the form of a rolling slope rather than by side filling which may damage the pipe. Backfilling from the sides of the trench will be permitted after sufficient material has first been carefully placed over the pipe to such a depth as to protect the pipe.

Compaction equipment used above the pipe zone shall be of a type that does not damage the pipe. Provide for the proper maintenance of traffic flow and accessibility as may be necessary. Make adequate provisions for the safety of property and persons. Temporary cribbing, sheeting, or other timbering shall be removed unless specifically authorized in writing. Dewatering shall be continued until the trench is completely backfilled. Brush, stumps, logs, planking, disconnected drains, boulders, etc., shall be removed from the material to be used for backfilling the trench.

(2) **GENERAL COMPACTION REQUIREMENTS.** Requirements of this section shall apply unless more stringent requirements are established by the local agency involved.

Trench backfill shall be compacted to the requirements of Item P-152.

(3) **MECHANICAL COMPACTION.** Method of compaction shall be at Contractor's option.

The Contractor shall be responsible to provide the proper size and type of compaction equipment and select the proper method of utilizing said equipment to attain the required compaction density. In-place compaction tests shall be made. Contractor shall remove and re-compact material that does not meet specified requirements.

**d. Removal of water and residual petroleum products from pipelines.** Any pipeline containing water or residual petroleum products after abandonment by the pipeline owner shall have the water or the residual products removed from the pipeline, by the Contractor, using a nitrogen purge, steam, or other approved means. The material removed from the pipeline shall be hauled away and disposed of properly. The Contractor shall assume that all pipelines to be removed contain significant amounts of residual products that must be disposed of offsite.

**150-3.3 BURIED UTILITY LINES.** The Contractor shall remove all abandoned electrical and telephone lines whether shown on the contract drawings or not. All

known lines are shown, but there may be other unknown abandoned lines in the area. It shall be the Contractor's responsibility to check the status of all abandoned lines. Care shall be taken to assure that all abandoned electric lines are not live and cannot be activated accidentally.

**150-3.4 GROUND SURFACE REPAIR.** The Contractor shall rough grade and compact areas affected by demolition to maintain site grades and contours. All holes remaining after demolition operations shall have sides broken down to flatten out the slopes, and shall be filled with acceptable material, moistened and properly compacted in layers to the density required in Item P-152, Excavation and Embankment. The ground surface area repaired shall properly drain and that water will not pond.

**150-3.5 INSPECTION POINTS.** Upon completion of demolition work and prior to backfilling operations, the DEN Project Manager shall inspect the Contractor's work. After backfilling and grading operations, the Contractor's Quality Control Inspector shall perform inspection and final acceptance, per Division 1 General Requirements Section 01 45 10 – Contractor Quality Control and Section 01 45 20 Contractor Quality Control Program - FAA.

**150-3.6 RECYCLED CRUSHED CONCRETE.** Recycled Crushed Concrete shall be placed in areas as detailed on the plans. Placement, shaping, and compaction shall follow the requirements for compaction and grade control outlined in this specification based upon the location the material is placed. Maximum particle size shall be 3 inches or less.

#### METHOD OF MEASUREMENT

**150-3.7 MEASUREMENT.** The yardage of gravel road removal to be measured for payment will be the actual square yardage as measured on the surface within the delineated areas. The linear feet of removal of pipe to be measured for payment will be the actual linear feet as measured within the delineated areas. The utility manhole removal to be measured for payment will be based on the actual number of manholes removed.

No direct payment will be made for other incidental demolition and removals required by this project except for those items paid for separately as noted in Basis of Payment section.

#### BASIS OF PAYMENT

**150-4.1 REMOVE RIPRAP.** Payment shall be made at the contract unit price per square yard of riprap material removed (rock and grout) and disposal of removed material off-site. This price shall be full compensation for furnishing all materials, and for all labor, equipment, tools, and incidentals necessary to complete the item.

**150-4.2 REMOVE 12" DIW (PVC).** Payment shall be made at the contract unit price per linear foot for pipe material removed and disposal of removed material off-site. This price shall be full compensation for furnishing all materials, and for all labor, equipment, tools, and incidentals necessary to complete the item.

**150-4.3 REMOVE 12” SDG (RCP).** Payment shall be made at the contract unit price per linear foot for pipe material removed and disposal of removed material off-site. This price shall be full compensation for furnishing all materials, and for all labor, equipment, tools, and incidentals necessary to complete the item.

**150-4.4 PLACE 6” RECYCLED CRUSHED CONCRETE.** Payment shall be made at the contract unit price per square yard of 6” recycled crushed concrete material place. This price shall be full compensation for furnishing all materials, and for all labor, equipment, tools, and incidentals necessary to complete the item.

|             |  |
|-------------|--|
| Item P-150a | Remove Riprap – Per Square Yard                      |
| Item P-150b | Remove 12” DIW (PVC) – Per Linear Foot               |
| Item P-150c | Remove 12” SDG (RCP) – Per Linear Foot               |
| Item P-150d | Remove DIW Manhole – Per Each                        |
| Item P-150e | Place 6” Recycled Crushed Concrete – Per Square Yard |

**END OF ITEM P-150**

## ITEM P-151 CLEARING AND GRUBBING

### DESCRIPTION

**151-1.1** This item shall consist of clearing or clearing and grubbing, including the disposal of materials, for all areas within the limits designated on the plans or as required by the DEN Project Manager. The designated areas shall be cleared and grubbed of six (6) inches of topsoil and vegetation prior to beginning any excavation or embankment operations. In addition, the Contractor shall clear, grub and strip an area 10 feet beyond the top of cut slopes and the toe of fill slopes.

**a.** Clearing shall consist of the cutting and removal of all trees, stumps, brush, logs, hedges, the removal of fences and other loose or projecting material from the designated areas. The grubbing of stumps and roots will not be required.

**b.** Clearing and grubbing shall consist of clearing the surface of the ground of the designated areas of all trees, stumps, down timber, logs, snags, brush, undergrowth, hedges, heavy growth of grass or weeds, fences, structures, debris, and rubbish of any nature, natural obstructions or such material which in the opinion of the DEN Project Manager is unsuitable for the foundation of strips, pavements, or other required structures, including the grubbing of stumps, roots, matted roots, foundations, and the disposal from the project of all spoil materials resulting from clearing and grubbing.

### CONSTRUCTION METHODS

**151-2.1 GENERAL.** The areas denoted on the plans to be cleared or cleared and grubbed shall be staked on the ground by the Contractor. The Contractor shall employ a Land Surveyor registered in the State of Colorado for the surveying work required. The clearing and grubbing shall be done at a satisfactory distance in advance of the grading operations.

All spoil materials removed by clearing or by clearing and grubbing shall be disposed of outside the Airport's limits at the Contractor's responsibility, except when otherwise directed by the DEN Project Manager

Blasting shall not be allowed.

The removal of existing structure and utilities required to permit orderly progress of work shall be accomplished by local agencies, unless otherwise shown on the plans. Whenever a telephone or telegraph pole, pipeline, conduit, sewer, roadway, or other utility is encountered and must be removed or relocated, the Contractor shall advise the DEN Project Manager who will notify the proper local authority or owner to secure prompt action.



**151-2.2 CLEARING.** The Contractor shall clear the staked or indicated area of all objectionable materials. Trees unavoidably falling outside the specified clearing limits must be cut up, removed, and disposed of in a satisfactory manner. To minimize damage to trees that are to be left standing, trees shall be felled toward the center of the area being cleared. The Contractor shall preserve and protect from injury all trees not to be removed. The trees, stumps, and brush shall be cut flush with flush with the original ground surface. The grubbing of stumps and roots will not be required.

Fences shall be removed and disposed of as directed by the DEN Project Manager. Fence wire shall be neatly rolled and the wire and posts stored on the airport if they are to be used again, or stored at a designated by the DEN Project Manager if the fence is to remain the property of a local owner or authority.

**151-2.3 CLEARING AND GRUBBING.** In areas designated to be cleared and grubbed, all stumps, roots, buried logs, brush, grass, and other unsatisfactory materials shall be removed, except where embankments exceeding 3-1/2 feet (105 cm) in depth will be constructed outside of paved areas. For embankments constructed outside of paved areas, all unsatisfactory materials shall be removed, but sound trees, stumps, and brush can be cut off flush with the original ground and allowed to remain. Tap roots and other projections over 1-1/2 inches (38 mm) in diameter shall be grubbed out to a depth of at least 18 inches (0.5 m) below the finished subgrade or slope elevation.

Any buildings and miscellaneous structures that are shown on the plans to be removed shall be demolished or removed, and all materials shall be disposed of by removal from the site. The cost of removal is incidental to this item. The remaining or existing foundations, wells, cesspools, and like structures shall be destroyed by breaking down the materials of which the foundations, wells, cesspools, etc., are built to a depth at least 2 feet (60 cm) below the existing surrounding ground. Any broken concrete, blocks, or other objectionable material that cannot be used in backfill shall be removed and disposed of at the Contractor's expense. The holes or openings shall be backfilled with acceptable material and properly compacted.

All holes under embankment areas remaining after the grubbing operation shall have the sides of the holes flattened to facilitate filling with acceptable material and compacting as required in Item P-152. The same procedure shall be applied to all holes remaining after grubbing in areas where the depth of holes exceeds the depth of the proposed excavation.

## METHOD OF MEASUREMENT

**151-3.1** The quantities of clearing or clearing and grubbing as shown by the limits on the plans or as ordered by the DEN Project Manager will not be paid for separately, but shall be considered incidental to other items of work.

### **BASIS OF PAYMENT**

**151-4.1** Payment of clearing or clearing and grubbing shall be considered incidental to other items of work.

**END OF ITEM P-151**



## ITEM P-152 EXCAVATION, SUBGRADE, AND EMBANKMENT

### DESCRIPTION

**152-1.1** This item covers excavation, disposal, placement, and compaction of all materials within the limits of the work required to construct safety areas, runways, taxiways, aprons, and intermediate areas as well as other areas for drainage, building construction, parking, or other purposes in accordance with these specifications and in conformity to the dimensions and typical sections shown on the plans.

**152-1.2 CLASSIFICATION.** All material excavated shall be classified as defined below:

**a. Unclassified Excavation.** Unclassified excavation shall consist of the excavation and disposal of all material, regardless of its nature.

**b. Borrow Excavation.** Borrow excavation shall consist of approved material required for the construction of embankments or for other portions of the work in excess of the quantity of usable material available from required excavations. Borrow material shall be obtained from areas designated by the DEN Project Manager within the limits of the airport property but outside the normal limits of necessary grading, or from areas outside the airport.

**152-1.3 UNSUITABLE EXCAVATION.** Any material containing vegetable or organic matter, such as muck, peat, organic silt, or sod shall be considered unsuitable for use in embankment construction. Material, suitable for topsoil may be used on the embankment slope when approved by the DEN Project Manager.

**152-1.4 MATERIAL CLASSIFICATION.** Non-cohesive soils, for the purposes of determining compaction control, are those with a plasticity index of less than 3 when tested in accordance with ASTM D 4318. Any other material shall be considered cohesive.

### CONSTRUCTION METHODS

**152-2.1 GENERAL.** Before beginning excavation, grading, and embankment operations in any area, the area shall be completely cleared and grubbed in accordance with Item P-151.

The suitability of material to be placed in embankments shall be subject to approval by the DEN Project Manager. All unsuitable material shall be disposed of in waste areas shown on the plans. All waste areas shall be graded to allow positive drainage of the area and of adjacent areas. The surface elevation of waste areas shall not extend above the surface

elevation of adjacent usable areas of the airport, unless specified on the plans or approved by the DEN Project Manager.

When the Contractor's excavating operations encounter artifacts of historical or archaeological significance, the operations shall be temporarily discontinued and the DEN Project Manager notified. At the direction of the DEN Project Manager, the Contractor shall excavate the site in such a manner as to preserve the artifacts encountered and allow for their removal. Such excavation will be paid for as extra work.

Those areas outside of the limits of the pavement areas where the top layer of soil material has become compacted by hauling or other Contractor activities shall be scarified and disked to a depth of 4 inches (100 mm), to loosen and pulverize the soil.

If it is necessary to interrupt existing surface drainage, sewers or under-drainage, conduits, utilities, or similar underground structures, the Contractor shall be responsible for and shall take all necessary precautions to preserve them or provide temporary services. When such facilities are encountered, the Contractor shall notify the DEN Project Manager, who shall arrange for their removal if necessary. The Contractor, at his or her expense, shall satisfactorily repair or pay the cost of all damage to such facilities or structures that may result from any of the Contractor's operations during the period of the contract.

**152-2.2 EXCAVATION.** No excavation shall be started until the work has been staked out by the Contractor and the DEN Project Manager has obtained from the Contractor, the survey notes of the elevations and measurements of the ground surface. All areas to be excavated shall be stripped of vegetation and topsoil. Topsoil shall be stockpiled for future use in areas designated on the plans or by the DEN Project Manager. All suitable excavated material shall be used in the formation of embankment, subgrade, or other purposes shown on the plans. All unsuitable material shall be disposed of as shown on the plans.

When the volume of the excavation exceeds that required to construct the embankments to the grades indicated, the excess shall be used to grade the areas of ultimate development or disposed as directed by the DEN Project Manager. When the volume of excavation is not sufficient for constructing the embankments to the grades indicated, the deficiency shall be obtained from borrow areas.

The grade shall be maintained so that the surface is well drained at all times. When necessary, temporary drains and drainage ditches shall be installed to intercept or divert surface water that may affect the work.

**a. Selective Grading.** When selective grading is indicated on the plans, the more suitable material designated by the DEN Project Manager shall be used in constructing the embankment or in capping the pavement subgrade. If, at the time of excavation, it is not possible to place this material in its final location, it shall be stockpiled in approved areas so that it can be measured for payment as specified in paragraph 152-3.3.

**b. Undercutting.** Rock, shale, hardpan, loose rock, boulders, or other material unsatisfactory for safety areas, subgrades, roads, shoulders, or any areas intended for turf shall be excavated to a minimum depth of 12 inches (300 mm) below the subgrade, or to the depth specified by the DEN Project Manager. Muck, peat, matted roots, or other yielding material, unsatisfactory for subgrade foundation, shall be removed to the depth specified. Unsuitable materials shall be disposed off the airport.

This excavated material shall be paid for at the contract unit price per cubic yard (per cubic meter) for Unclassified Excavation. The excavated area shall be backfilled with suitable material obtained from the grading operations or borrow areas and compacted to specified densities. The necessary backfill will constitute a part of the embankment. Where rock cuts are made, backfill with select material. Any pockets created in the rock surface shall be drained in accordance with the details shown on the plans.

**c. Overbreak.** Overbreak, including slides, is that portion of any material displaced or loosened beyond the finished work as planned or authorized by the DEN Project Manager. All overbreak shall be graded or removed by the Contractor and disposed of as directed by the DEN Project Manager. The DEN Project Manager shall determine if the displacement of such material was unavoidable and his or her decision shall be final. Payment will not be made for the removal and disposal of overbreak that the DEN Project Manager determines as avoidable. Unavoidable overbreak will be classified as “Unclassified Excavation.”

**d. Hazardous Materials.** Some material (equipment, debris, soil, wastes, etc.) may be affected by hazardous constituents, chemicals or compounds used during oil and gas production, residential development, public improvement construction or agricultural use. Material contaminated or potentially contaminated with hazardous constituents, chemicals or compounds shall be assessed by the contractor regarding the hazardous characteristic(s) of each material. The assessment will be made in accordance with requirements specified by the Colorado Department of Public Health and Environment (CDPHE) and the Colorado Department of Natural Resources - Oil and Gas Conservation Commission (OGCC). The Contractor shall notify the Engineer in writing immediately upon discovery or suspicion of the existence of such hazardous material.

**e. Removal of Utilities.** The removal of existing structures and utilities required to permit the orderly progress of work will be accomplished by someone other than the Contractor; for example, the utility unless otherwise shown on the plans. All existing foundations shall be excavated at least 2 feet (60 cm) below the top of subgrade or as indicated on the plans, and the material disposed of as directed by the DEN Project Manager. All foundations thus excavated shall be backfilled with suitable material and compacted as specified.

**f. Compaction Requirements.** The subgrade under areas to be paved shall be compacted to a depth of 8 inches and to a density of not less than 95 percent of the maximum density as determined by ASTM 698. The material to be compacted shall be within +/- 2% of

optimum moisture content before being rolled to obtain the prescribed compaction (except for expansive soils).

The in-place field density shall be determined in accordance with ASTM D 1556 or ASTM D6938 and shall be used to determine the moisture content of the material. The machine shall be calibrated in accordance with ASTM D 6938. Stones or rock fragments larger than 4 inches (100 mm) in their greatest dimension will not be permitted in the top 6 inches (150 mm) of the subgrade. The finished grading operations, conforming to the typical cross-section, shall be completed and maintained at least 1,000 feet (300 m) ahead of the paving operations or as directed by the DEN Project Manager.

All testing shall be done by a laboratory hired by the Contractor. The results shall be furnished daily to the Engineer for determination of acceptance.

In areas of excavation, a minimum of two density and moisture content tests shall be taken per day or a minimum of one test per 1000 square yards, whichever results in a greater number of tests. Density and moisture content tests are only required on the final surface. If field-tested density or moisture content of the final surface is found to be outside of a specified range, the area represented by the test shall be re-worked and re-tested. Pavement materials shall not be placed on the completed surface until testing results have been furnished to, and approved in writing by the Engineer.

All loose or protruding rocks on the back slopes of cuts shall be pried loose or otherwise removed to the slope finished grade line. All cut-and-fill slopes shall be uniformly dressed to the slope, cross-section, and alignment shown on the plans or as directed by the DEN Project Manager.

Blasting shall not be allowed.

**g. Proof Rolling.** After compaction is completed, the subgrade area shall be proof rolled with a 20 ton (18.1 metric ton) Tandem axle Dual Wheel Dump Truck loaded to the legal limit with tires inflated to 100 psi (0.689 MPa) in the presence of the DEN Project Manager. Apply a minimum of 50% coverage, or as specified by the DEN Project Manager, to all paved areas. A coverage is defined as the application of one tire print over the designated area. Soft areas of subgrade that deflect more than 1 inch (25 mm) or show permanent deformation greater than 1 inch (25 mm) shall be removed and replaced with suitable material or reworked to conform to the moisture content and compaction requirements in accordance with these specifications.

**152-2.3 BORROW EXCAVATION.** Borrow areas within the airport property are indicated on the plans. Borrow excavation shall be made only at these designated locations and within the horizontal and vertical limits as staked or as directed.

When borrow sources are outside the boundaries of the airport property, it shall be the Contractor's responsibility to locate and obtain the borrow source, subject to the approval of the DEN Project Manager. The Contractor shall notify the DEN Project Manager at least 15

days prior to beginning the excavation so necessary measurements and tests can be made. All borrow pits shall be opened up to expose the various strata of acceptable material to allow obtaining a uniform product. All unsuitable material shall be disposed of by the Contractor. Borrow pits shall be excavated to regular lines to permit accurate measurements, and they shall be drained and left in a neat, presentable condition with all slopes dressed uniformly.

**152-2.4 DRAINAGE EXCAVATION.** Drainage excavation shall consist of excavating for drainage ditches such as intercepting; inlet or outlet ditches; for temporary levee construction; or for any other type as designed or as shown on the plans. The work shall be performed in sequence with the other construction. Intercepting ditches shall be constructed prior to starting adjacent excavation operations. All satisfactory material shall be placed in embankment fills; unsuitable material shall be placed in designated waste areas or as directed by the DEN Project Manager. All necessary work shall be performed true to final line, elevation, and cross-section. The Contractor shall maintain ditches constructed on the project to the required cross-section and shall keep them free of debris or obstructions until the project is accepted.

**152-2.5 PREPARATION OF EMBANKMENT AREA.** Where an embankment is to be constructed to a height of 4 feet (1.2 m) or less, all sod and vegetative matter shall be removed from the surface upon which the embankment is to be placed. The cleared surface shall be broken up by plowing or scarifying to a minimum depth of 6 inches (150 mm) and shall then be compacted as indicated in paragraph 152-2.6. When the height of fill is greater than 4 feet (1.2 m), sod not required to be removed shall be thoroughly disked and recompacted to the density of the surrounding ground before construction of embankment.

Sloped surfaces steeper than one (1) vertical to four (4) horizontal shall be plowed, stepped, benched, or broken up so that the fill material will bond with the existing material. When the subgrade is part fill and part excavation or natural ground, the excavated or natural ground portion shall be scarified to a depth of 12 inches (300 mm) and compacted as specified for the adjacent fill.

No direct payment shall be made for the work performed under this section. The necessary clearing and grubbing and the quantity of excavation removed will be paid for under the respective items of work.

**152-2.6 FORMATION OF EMBANKMENTS.** Embankments shall be formed in successive horizontal layers of not more than 8 inches (200 mm) in loose depth for the full width of the cross-section, unless otherwise approved by the DEN Project Manager.

The layers shall be placed, to produce a soil structure as shown on the typical cross-section or as directed by the DEN Project Manager. Materials such as brush, hedge, roots, stumps, grass and other organic matter, shall not be incorporated or buried in the embankment.

Earthwork operations shall be suspended at any time when satisfactory results cannot be obtained because of rain, freezing, or other unsatisfactory weather conditions in the field.



Frozen material shall not be placed in the embankment nor shall embankment be placed upon frozen material. Material shall not be placed on surfaces that are muddy, frozen, or contain frost. The Contractor shall drag, blade, or slope the embankment to provide surface drainage at all times.

The material in each layer shall be within  $\pm 2\%$  of optimum moisture content before rolling to obtain the prescribed compaction. To achieve a uniform moisture content throughout the layer, the material shall be moistened or aerated as necessary. Samples of all embankment materials for testing, both before and after placement and compaction, will be taken for each 1000 square yards. Based on these tests, the Contractor shall make the necessary corrections and adjustments in methods, materials or moisture content to achieve the specified embankment density.

Rolling operations shall be continued until the embankment is compacted to not less than 95% of maximum density for noncohesive soils, and 90% of maximum density for cohesive soils as determined by ASTM 698. Under all areas to be paved, the embankments shall be compacted to a depth of 8 inches to a density of not less than 95 percent of the maximum density as determined by ASTM 698.

On all areas outside of the pavement and RPP liner areas, no compaction will be required on the top 4 in (100 mm).

The in-place field density shall be determined in accordance with ASTM D1556 or ASTM D6938 using Procedure A, the direct transmission method, and ASTM D6938 shall be used to determine the moisture content of the material. The machine shall be calibrated in accordance with ASTM D6938. The Contractor's laboratory shall perform all density tests in the DEN Project Manager's presence and provide the test results upon completion to the DEN Project Manager for acceptance.

In embankment areas, a minimum of two density and moisture content tests shall be taken per lift per day or a minimum of one test per 1,000 cubic yards of material placed, whichever results in a greater number of tests. If field-tested density or moisture content of a completed lift is found to be outside of a specified range, the area represented by the test shall be re-worked and re-tested. Additional embankment or pavement materials shall not be placed on the completed lift or area until testing results have been furnished to, and approved in writing by the DEN Project Manager.

Compaction areas shall be kept separate, and no layer shall be covered by another layer until the proper density is obtained.

During construction of the embankment, the Contractor shall route all construction equipment evenly over the entire width of the embankment as each layer is placed. Layer placement shall begin in the deepest portion of the embankment fill. As placement progresses, the layers shall be constructed approximately parallel to the finished pavement grade line.

When rock and other embankment material are excavated at approximately the same time, the rock shall be incorporated into the outer portion of the embankment and the other material shall be incorporated under the future paved areas. Stones or fragmentary rock larger than 4 inches (100 mm) in their greatest dimensions will not be allowed in the top 6 inches (150 mm) of the subgrade. Rockfill shall be brought up in layers as specified or as directed by the DEN Project Manager and the finer material shall be used to fill the voids with forming a dense, compact mass. Rock or boulders shall not be disposed of outside the excavation or embankment areas, except at places and in the manner designated on the plans or by the DEN Project Manager.

When the excavated material consists predominantly of rock fragments of such size that the material cannot be placed in layers of the prescribed thickness without crushing, pulverizing or further breaking down the pieces, such material may be placed in the embankment as directed in layers not exceeding 2 feet (60 cm) in thickness. Each layer shall be leveled and smoothed with suitable equipment by distribution of spalls and finer fragments of rock. The layer shall not be constructed above an elevation 4 feet (1.2 m) below the finished subgrade.

There will be no separate measurement of payment for compacted embankment. All costs incidental to placing in layers, compacting, discing, watering, mixing, sloping, and other operations necessary for construction of embankments will be included in the contract price for excavation, borrow, or other items.

**152-2.7 FINISHING AND PROTECTION OF SUBGRADE.** After the subgrade is substantially complete, the Contractor shall remove any soft or other unstable material over the full width of the subgrade that will not compact properly. All low areas, holes or depressions in the subgrade shall be brought to grade with suitable select material. Scarifying, blading, rolling and other methods shall be performed to provide a thoroughly compacted subgrade shaped to the lines and grades shown on the plans.

Grading of the subgrade shall be performed so that it will drain readily. The Contractor shall protect the subgrade from damage and limit hauling over the finished subgrade to only traffic essential for construction purposes. All ruts or rough places that develop in the completed subgrade shall be graded and recompact.

No subbase, base, or surface course shall be placed on the subgrade until the subgrade has been approved by the DEN Project Manager.

**152-2.8 HAUL.** All hauling will be considered a necessary and incidental part of the work. The Contractor shall include the cost in the contract unit price for the pay of items of work involved. No payment will be made separately or directly for hauling on any part of the work.

**152-2.9 TOLERANCES.** In those areas upon which a subbase or base course is to be placed, the top of the subgrade shall be of such smoothness that, when tested with a 12-foot (3.7-m) straightedge applied parallel and at right angles to the centerline, it shall not show any deviation in excess of 1/2 inch (12 mm), and shall not be more than 0.05 feet (15 mm)

from true grade as established by grade hubs. The smoothness measurements shall be made by the Contractor on a 50-foot grid parallel and perpendicular to the centerline in the presence of the DEN Project Manager. The grade shall be determined at spot elevations shown on the Plans for the surface course, on a grid not to exceed 50 feet. Any deviation in excess of these amounts shall be corrected by loosening, adding, or removing materials; reshaping; and recompacting.

On safety areas, intermediate and other designated areas, the surface shall be of such smoothness that it will not vary more than 0.10 feet (3 mm) from true grade as shown on the typical sections and/or contours shown on the plans and meeting FAA grading criteria. Any deviation in excess of this amount shall be corrected by loosening, adding or removing materials, and reshaping.

**152-2.10 TOPSOIL.** When topsoil is specified or required as shown on the plans or under Item T-905, it shall be salvaged from stripping or other grading operations. The topsoil shall meet the requirements of Item T-905. If, at the time of excavation or stripping, the topsoil cannot be placed in its final section of finished construction, the material shall be stockpiled at approved locations. Stockpiles shall not be placed within 300 feet of runway pavement or 100 feet of taxiway pavement and shall not be placed on areas that subsequently will require any excavation or embankment fill. If, in the judgment of the DEN Project Manager, it is practical to place the salvaged topsoil at the time of excavation or stripping, the material shall be placed in its final position without stockpiling or further rehandling.

Upon completion of grading operations, stockpiled topsoil shall be handled and placed as directed, or as required in Item T-905.

No direct payment will be made for topsoil under Item P-152. The quantity removed and placed directly or stockpiled shall be paid for at the contract unit price per cubic yard (cubic meter) for “Unclassified Excavation.”

When stockpiling of topsoil and later rehandling of such material is directed by the DEN Project Manager, cost associated with rehandling will not be measured or paid for separately, but will be considered incidental to “Unclassified Excavation”

**152-2.11 RESTORING BORROW AREAS.** The Contractor shall, upon completion of his borrow excavation activities, prepare the borrow sites for planting by performing the following work:

- a. Remove and bury all rock over 6" in dimension in accordance with rock disposal methods as noted under Section 3.02 Excavation P-152.
- b. Grade all sites to drain as indicated in these specifications and drawings.
- c. Remove all trash and other foreign objects so that the areas can be reused for farming purposes.

**d.** Rip the borrow area site in a manner as approved by the DEN Project Manager. After the area is ripped to the 18 inch ( 450 mm) depth, the area ripped shall be treated on the surface to reduce excessive surface roughness or cloddiness and produce an area suitable for future seeding. Treatment may include discing, harrowing, cultipacking or other means as approved by the Engineer. In areas where rock is the predominant surface remaining, the Contractor may spread 18 inches (450 mm) of acceptable material over the rock areas as approved by the Engineer at no additional cost to the City.

All work required to prepare the borrow area for planting as designated under this section shall be considered as incidental work.

**152-2.13** There shall be no direct measurement or payment for Borrow Material associated with the project. The work under this item shall be considered incidental to the project.

**152-2.14** There shall be no direct measurement or payment for Stockpiled Material associated with the project. The work under this item shall be considered incidental to the project.

### **METHOD OF MEASUREMENT**

**152-3.1** The quantity of excavation to be paid for shall be the number of cubic yards (cubic meters) measured in its original position.

Measurement shall not include the quantity of materials excavated without authorization beyond normal slope lines, or the quantity of material used for purposes other than those directed.

**152-3.2** For payment specified by the cubic yard (cubic meter), measurement for all excavation shall be computed by the average end area method. The end area is that bound by the original ground line established by field cross sections and the final theoretical pay line established by excavation cross sections shown on the plans, subject to verification by the Engineer. After completion of all excavation operations and prior to the placing of base or subbase material, the final excavation shall be verified by the Engineer by means of field cross sections taken randomly at intervals not exceeding 500 linear feet (150 meters).

### **BASIS OF PAYMENT**

**152-5.1** “Unclassified excavation” payment shall be made at the contract unit price per cubic yard (cubic meter). This price shall be full compensation for furnishing all materials, labor, equipment, tools, and incidentals necessary to complete the item.

Payment will be made under:

Item P-152a           Unclassified Excavation—per cubic yard (cubic meter)

**TESTING REQUIREMENTS**

ASTM D698           Test for Moisture-Density Relations of Soils and Soil-Aggregate Mixtures, Using 5.5-pound (2.49 kg) Rammer and 12 in (305 mm) Drop

ASTM D1556         Test for Density of Soil In Place by the Sand-Cone Method

ASTM D1557         Test for Laboratory Compaction Characteristics of Soil Using Modified Effort

ASTM D2167         Test for Density and Unit Weight of Soil In Place by the Rubber Balloon Method.

ASTM D6938         In-Place Density and Water Content of Soil and Soil-Aggregate by Nuclear Methods

**END OF ITEM P-152**

## ITEM P-153 CONTROLLED LOW-STRENGTH MATERIAL (CLSM)

### DESCRIPTION

**153-1.1** This item shall consist of furnishing, transporting, and placing a controlled low-strength material (CLSM) as flowable backfill in trenches or at other locations shown on the plans or as directed by the DEN Project Manager.

### MATERIALS

#### 153-2.1 MATERIALS

**a. Portland Cement.** Portland cement shall conform to the requirements of ASTM C 150 Type I or II. If for any reason, cement becomes partially set or contains lumps of caked cement, it shall be rejected. Cement salvaged from discarded or used bags shall not be used.

**b. Fly Ash.** Flyash shall conform to ASTM C618, Class C or F.

**c. Fine Aggregate (Sand).** Fine aggregate shall conform to the requirements of ASTM C33 except for aggregate gradation. Any aggregate gradation which produces performance characteristics of the CLSM specified here will be accepted, except as follows.

| Sieve Size         | Percent Passing by weight |
|--------------------|---------------------------|
| 3/4 inch (19 mm)   | 100                       |
| No. 200 (0.075 mm) | 0 – 12                    |

**d. Water.** Water used in mixing shall be potable and free of oil, salt, acid, alkali, sugar, vegetable matter, or other substances injurious to the finished product.

### MIX DESIGN

**153-3.1 PROPORTIONS.** The Contractor shall submit, to the DEN Project Manager, a mix design including the proportions and source of aggregate, fly ash, cement, water, and approved admixtures. No CLSM mixture shall be produced for payment until the DEN Project Manager has given written approval of the proportions. The proportions shall be prepared by a laboratory and shall remain in effect for the duration of the project. Laboratory costs are incidental to this item. The proportions shall establish a single percentage or weight for aggregate, fly ash, cement, water, and any admixtures proposed.

**a. Compressive Strength.** CLSM shall be designed to achieve a 28-day compressive strength of 100 to 300 psi (690 to 2,068 kPa) when tested in accordance with ASTM D4832. There should be no significant strength gain after 28 days.

**b. Consistency.** CLSM should be designed to achieve a consistency that will produce an approximate 8-inch (200 mm) diameter circular-type spread without segregation when tested by: (1) filling a 3-inch inside diameter by 6-inch length flow cylinder (non-absorbent pipe) (2) strike off of the flow cylinder and start of lift within five seconds of filling and (3) by steady upward pull, lift the cylinder in a time period of between two and four seconds. Adjustments of the material proportions should be made to achieve proper solid suspension and flowable characteristics, however the theoretical yield shall be maintained at one cubic yard (cubic meter) for the given batch weights.

## CONSTRUCTION METHODS

### 153-4.1 PLACEMENT.

**a. Placement.** CLSM may be placed by any reasonable means from a mixing unit into the space to be filled. Agitation is required during transportation and waiting time. Placement shall be performed so structures or pipes are not displaced from their final position and intrusion of CLSM into unwanted areas is avoided. The material shall be brought up uniformly to the fill line shown on the plans or as directed by the DEN Project Manager. Each placement of CLSM shall be as continuous an operation as possible. If CLSM is placed in more than one layer, the base layer shall be free of surface water and loose foreign material prior to placement of the next layer.

**b. Limitations of Placement.** CLSM shall not be placed on frozen ground. Mixing and placing may begin when the air or ground temperature is at least 35°F (2°C) and rising. At the time of placement, CLSM shall have a temperature of at least 40°F (4°C). Mixing and placement shall stop when the air temperature is 40°F (4°C) and falling or when the anticipated air or ground temperature will be 35°F (2°C) or less in the 24 hour period following proposed placement.

### 153-4.2 CURING AND PROTECTION

**a. Curing.** The air in contact with the CLSM shall be maintained at temperatures above freezing for a minimum of 72 hours. If the CLSM is subjected to temperatures below 32°F (0°C), the material may be rejected by the DEN Project Manager if damage to the material is observed.

**b. Protection.** The CLSM shall not be subject to loads and shall remain undisturbed by construction activities for a period of 48 hours or until a compressive strength of 15 psi (105 kPa) is obtained. The Contractor shall be responsible for providing evidence to the DEN Project Manager that the material has reached the desired strength. Acceptable evidence shall be based upon compressive tests made in accordance with paragraph 153-3.1a.

**153-4.3 Acceptance.** Acceptance of CLSM delivered and placed as shown on the plans or as directed by the DEN Project Manager shall be based upon mix design approval and batch tickets provided by the Contractor to confirm that the delivered material conforms to the mix design. The Contractor shall verify by additional testing, each 1,000 cubic yards (765 cubic meters) of material used. Verification shall include confirmation of material proportions and tests of compressive strength to confirm that the material meets the original mix design and the requirements of CLSM as defined in this specification. Adjustments shall be made as necessary to the proportions and materials prior to further production.

#### **METHOD OF MEASUREMENT**

**153-5.1** There shall be no direct measurement or payment for CLSM. The work under this item shall be considered subsidiary to other items of work.

#### **BASIS OF PAYMENT**

**153-6.1** CLSM shall be considered incidental to the project. No payment shall be made for CLSM.

#### **TESTING REQUIREMENTS**

ASTM D4832 Standard Test Method for Preparation and Testing of Controlled Low-Strength Material (CLSM) Test Cylinders

#### **MATERIAL REQUIREMENTS**

ASTM C33 Standard Specification for Concrete Aggregates  
ASTM C150 Standard Specification for Portland Cement  
ASTM C618 Standard Specification for Coal Fly Ash and Raw or Calcined Natural Pozzolan for Use in Concrete  
ASTM C595 Standard Specification for Blended Hydraulic Cements

**END OF ITEM P-153**





## ITEM P-610 STRUCTURAL PORTLAND CEMENT CONCRETE

### DESCRIPTION

**610-1.1** This item shall consist of reinforced structural portland cement concrete (PCC), prepared and constructed in accordance with these specifications, at the locations and of the form and dimensions shown on the plans. This specification shall be used for all structural and miscellaneous concrete including signage bases.

### MATERIALS

**610-2.1 GENERAL.** Only approved materials, conforming to the requirements of these specifications, shall be used in the work. Materials may be subject to inspection and tests at any time during their preparation or use. The source of all materials shall be approved by the DEN Project Manager before delivery or use in the work. Representative preliminary samples of the materials shall be submitted by the Contractor, when required, for examination and test. Materials shall be stored and handled to ensure preservation of their quality and fitness for use and shall be located to facilitate prompt inspection. All equipment for handling and transporting materials and concrete must be clean before any material or concrete is placed in them.

The use of pit-run aggregates shall not be permitted unless the pit-run aggregate has been screened and washed, and all fine and coarse aggregates stored separately and kept clean. The mixing of different aggregates from different sources in one storage stockpile or alternating batches of different aggregates shall not be permitted.

**a. Reactivity.** Fine and Coarse aggregates to be used in all concrete shall be evaluated and tested by the Contractor for alkali-aggregate reactivity in accordance with both ASTM C1260 and C1567. The laboratory performing the tests shall be accredited in accordance with ASTM C1077. The laboratory accreditation must be current and listed on the accrediting authority's website. Test method ASTM C1260 must be listed on the lab accreditation. A copy of the laboratory's current accreditation and accredited test methods shall be submitted to the DEN Project Manager prior to start of construction. Aggregate and mix proportion reactivity tests shall be performed for each project.

(1) Coarse and fine aggregate shall be tested separately in accordance with ASTM C1260. The aggregate shall be considered innocuous if the expansion of test specimens, tested in accordance with ASTM C1260, does not exceed 0.10% at 28 days (30 days from casting).

(2) Combined coarse and fine aggregate shall be tested in accordance with ASTM C1567, modified for combined aggregates, using the proposed mixture design proportions of aggregates, cementitious materials, and/or specific reactivity reducing

chemicals. If lithium nitrate is proposed for use with or without supplementary cementitious materials, the aggregates shall be tested in accordance with Corps of Engineers (COE) CRD C662. If lithium nitrate admixture is used, it shall be nominal 30% ±0.5% weight lithium nitrate in water.

(3) If the expansion of the proposed combined materials test specimens, tested in accordance with ASTM C1567, modified for combined aggregates, or COE CRD C662, does not exceed 0.10% at 28 days, the proposed combined materials will be accepted. If the expansion of the proposed combined materials test specimens is greater than 0.10% at 28 days, the aggregates will not be accepted unless adjustments to the combined materials mixture can reduce the expansion to less than 0.10% at 28 days, or new aggregates shall be evaluated and tested.

**610-2.2 COARSE AGGREGATE.** The coarse aggregate for concrete shall meet the requirements of ASTM C33. Crushed stone aggregate shall have a durability factor, as determined by ASTM C666, greater than or equal to 95. The DEN Project Manager may consider and reserve final approval of other State classification procedures addressing aggregate durability.

Coarse aggregate shall be well graded from coarse to fine and shall meet the following gradation shown in the table below when tested per ASTM C136.

**Gradation For Coarse Aggregate**

| Sieve Designation<br>(square openings) | Percentage by Weight<br>Passing Sieves |                      |                  |                    |                    |                   |       |       |
|--|--|----------------------|------------------|--------------------|--------------------|-------------------|-------|-------|
|  | 2"<br>(50<br>mm)                       | 1-1/2"<br>(38<br>mm) | 1"<br>(25<br>mm) | 3/4"<br>(19<br>mm) | 1/2"<br>(12<br>mm) | 3/8"<br>(9<br>mm) | No. 4 | No. 8 |
| No. 4 to 3/4 in. (4.75-19mm)           |  |                      | 100              | 90-100             |                    | 20-55             | 0-10  | 0-5   |
| No. 4 to 1 in. (4.75-25mm)             |  | 100                  | 90-100           |                    | 25-60              |                   | 0-10  | 0-5   |

a. Coarse aggregate may be accepted from sources that have a 20 year service history for the same gradation to be supplied with no durability issues.

(1) Material currently being produced shall have a durability factor ≥ 95 using ASTM C666. Coarse aggregates that are crushed granite, calcite cemented sandstone, quartzite, basalt, diabase, rhyolite or trap rock are considered to meet the D-cracking test but must meet all other quality tests. Aggregates meeting State Highway Department material specifications may be acceptable with concurrence of the FAA.

(2) The Contractor shall submit a current certification that the aggregate does not have a history of D-cracking and that the aggregate meets the state specifications for use in PCC pavement for use on interstate highways. Certifications, tests and any history

reports must be for the same gradation as being proposed for use on the project. Certifications which are not dated or which are over one (1) year old or which are for different gradations will not be accepted. Test results will only be accepted when tests were performed by a State Department of Transportation (DOT) materials laboratory or an accredited laboratory.

**610-2.3 Fine Aggregate.** The fine aggregate for concrete shall meet the requirements of ASTM C33.

The fine aggregate shall be well graded from fine to coarse and shall meet the requirements of the table below when tested in accordance with ASTM C136:

**Gradation For Fine Aggregate**

| <b>Sieve Designation<br/>(square openings)</b> | <b>Percentage by Weight<br/>Passing Sieves</b> |
|--|--|
| 3/8 inch (9 mm)                                | 100  |
| No. 4 (4.75 mm)                                | 95-100   |
| No. 8 (2.36 mm)                                | 80-100   |
| No. 16 (1.18 mm)                               | 50-85  |
| No. 30 (0.60 mm)                               | 25-60  |
| No. 50 (0.30 mm)                               | 10-30  |
| No. 100 (0.15 mm)                              | 2-10   |

Blending will be permitted, if necessary, to meet the gradation requirements for fine aggregate. Fine aggregate deficient in the percentage of material passing the No. 50 mesh sieve may be accepted, if the deficiency does not exceed 5% and is remedied by the addition of pozzolanic or cementitious materials other than Portland cement, as specified in paragraph 610-2.6, Admixtures, in sufficient quantity to produce the required workability as approved by the DEN Project Manager.

**610-2.4 CEMENT.** Cement shall conform to the requirements of ASTM C150 Type I/II.

If aggregates are deemed innocuous when tested in accordance with paragraph 610-2.1.a.1 and accepted in accordance with paragraph 610-2.1.a.3, higher equivalent alkali content in the cement may be allowed if approved by the DEN Project Manager and FAA. If cement becomes partially set or contains lumps of caked cement, it shall be rejected. Cement salvaged from discarded or used bags shall not be used.

The Contractor shall furnish vendors' certified test reports for each carload, or equivalent, of cement shipped to the project. The report shall be delivered to the DEN Project Manager

before use of the cement is granted. All test reports shall be subject to verification by testing sample materials received for use on the project.

**610-2.5 WATER.** The water used in concrete shall be fresh, clean and potable; free from injurious amounts of oils, acids, alkalies, salts, organic materials or other substances deleterious to concrete.

**610-2.6 ADMIXTURES.** The Contractor shall submit certificates indicating that the material to be furnished meets all of the requirements indicated below. In addition, the DEN Project Manager may require the Contractor to submit complete test data from an approved laboratory showing that the material to be furnished meets all of the requirements of the cited specifications. Subsequent tests may be made of samples taken by the DEN Project Manager from the supply of the material being furnished or proposed for use on the work to determine whether the admixture is uniform in quality with that approved.

**a. Air-Entraining Admixtures.** Air-entraining admixtures shall meet the requirements of ASTM C260 and shall consistently entrain the air content in the specified ranges under field conditions. The air-entrainment agent and any water reducer admixture shall be compatible.

**b. Water-Reducing Admixtures.** Water-reducing admixture shall meet the requirements of ASTM C494, Type A, B, or D. ASTM C494, Type F and G high range water reducing admixtures and ASTM C1017 flowable admixtures shall not be used.

**c. Other Chemical Admixtures.** The use of set retarding, and set-accelerating admixtures shall be approved by the DEN Project Manager. Retarding shall meet the requirements of ASTM C494, Type A, B, or D and set-accelerating shall meet the requirements of ASTM C494, Type C. Calcium chloride and admixtures containing calcium chloride shall not be used.

**d. Lithium Nitrate.** The lithium admixture shall be a nominal 30% aqueous solution of Lithium Nitrate, with a density of 10 pounds/gallon (1.2 kg/L), and shall have the approximate chemical form as shown below:

| <u>Constituent</u>                  | <u>Limit (Percent by Mass)</u> |
|-------------------------------------|--------------------------------|
| LiNO <sub>3</sub> (Lithium Nitrate) | 30 ±0.5                        |
| SO <sub>4</sub> (Sulfate Ion)       | 0.1 (max)                      |
| Cl (Chloride Ion)                   | 0.2 (max)                      |
| Na (Sodium Ion)                     | 0.1 (max)                      |
| K (Potassium Ion)                   | 0.1 (max)                      |

Provide a trained representative to supervise the lithium nitrate admixture dispensing and mixing operations.

**e. Fly ash.** Fly ash shall meet the requirements of ASTM C618, with the exception of loss of ignition, where the maximum shall be less than 6%. Fly ash for use in

mitigating alkali-silica reactivity shall have a Calcium Oxide (CaO) content of less than 13%.

**610-2.7 PREMOLDED JOINT MATERIAL.** Premolded joint material for expansion joints shall meet the requirements of ASTM D 1751.

**610-2.8 JOINT FILLER.** The filler for joints shall meet the requirements of Item P-605, unless otherwise specified.

**610-2.9 STEEL REINFORCEMENT.** Reinforcing shall conform to the following requirements.

**610-2.10 MATERIALS FOR CURING CONCRETE.** Curing materials shall conform to one of the following specifications:

ASTM C 171 Waterproof paper

ASTM C 171 Clear or White Polyethylene Sheeting

ASTM C 309 White-pigmented Liquid Membrane-Forming Compound, Type 2, Class B

**610-2.11 FIBROUS REINFORCEMENT**

a. 100% Virgin, Polypropylene fibrillated fibers containing no reprocessed olefin materials and having tensile strength of not less than 80 ksi with multi-grade fiber lengths per manufacturer’s recommendation of concrete type and application. Current ICBO approval required. Conform to ASTM C1116, Type III, 4.1.3., performance Level I. Fibers shall be between 3/8” and 3/4” in length. Multigraded fibers shall be manufactured in accordance with a gradation curve formula which will produce a blend of not less than 20 individual fiber designs.

b. Acceptable Products: Fibermesh 300” by Fibermesh, Inc. or approved equal.

**CONSTRUCTION METHODS**

**610-3.1 GENERAL.** The Contractor shall furnish all labor, materials, and services necessary for, and incidental to, the completion of all work as shown on the drawings and specified here. All machinery and equipment used by the Contractor on the work, shall be of sufficient size to meet the requirements of the work. All work shall be subject to the inspection and approval of the DEN Project Manager.

**610-3.2 CONCRETE COMPOSITION.** The concrete shall develop a compressive strength of 4,500 psi in 28 days as determined by test cylinders made in accordance with ASTM C31 and tested in accordance with ASTM C39. The concrete shall contain 615 to 660 pounds of cementitious material (cement plus fly ash) per cubic yard. The water/cementitious material ratio shall be 0.45 (maximum). The concrete shall contain 5% to 8% of entrained air,

as determined by ASTM C231 and shall have a slump of not more than 4 inches (100 mm) as determined by ASTM C143.

**610-3.3 ACCEPTANCE SAMPLING AND TESTING.** Concrete for each structure will be accepted on the basis of the compressive strength specified in paragraph 610-3.2. The concrete shall be sampled in accordance with ASTM C172. The first load of concrete, per mix, delivered each day will be sampled and tested.

Concrete placed for structures will be sampled and tested for each additional 50 cubic yards per day with a minimum one test per structure. When a single load of concrete is used for more than one structure, that load will be sampled and tested once.

Concrete placed for light cans will be sampled and tested for each additional 50 cubic yards per day.

Lean concrete will be sampled and tested for each additional 50 cubic yards per day.

Concrete cylindrical compressive strength specimens shall be made in accordance with ASTM C31 and tested in accordance with ASTM C39. Concrete strengths for acceptance shall be the average of at least two 6 by 12 inch or at least three 4 by 8 inch cylinders tested at 28 days. Contractor shall provide the initial on-site storage facilities for the specimens. The on-site storage facilities shall be capable of maintaining a temperature range of 60 to 80°F (16 to 27°C). The Contractor shall cure and store the test specimens under such conditions as directed by the Engineer. The DEN Project Manager/Engineer will make the actual tests on the specimens at no expense to the Contractor.

**610-3.4 QUALIFICATIONS FOR CONCRETE TESTING SERVICE.** Perform concrete testing by an approved laboratory and inspection service experienced in sampling and testing concrete. Testing agency must meet the requirements of ASTM C1077 or ASTM E329.

**610-3.5 PROPORTIONING AND MEASURING DEVICES.** When package cement is used, the quantity for each batch shall be equal to one or more whole sacks of cement. The aggregates shall be measured separately by weight. If aggregates are delivered to the mixer in batch trucks, the exact amount for each mixer charge shall be contained in each batch compartment. Weighing boxes or hoppers shall be approved by the DEN Project Manager and shall provide means of regulating the flow of aggregates into the batch box so the required, exact weight of aggregates is obtained.

**610-3.6 CONSISTENCY.** The consistency of the concrete shall be determined by the slump test specified in ASTM C143.

**610-3.7 MIXING.** Concrete may be mixed at the construction site, at a central point, or wholly or in part in truck mixers. The concrete shall be mixed and delivered in accordance with the requirements of ASTM C94.

**610-3.8 MIXING CONDITIONS.** The concrete shall be mixed only in quantities required for immediate use. Concrete shall not be mixed while the air temperature is below 40°F (4°C) without permission of the DEN Project Manager. If permission is granted for mixing under such conditions, aggregates or water, or both, shall be heated and the concrete shall be placed at a temperature not less than 50°F (10°C) nor more than 100°F (38°C). The Contractor shall be held responsible for any defective work, resulting from freezing or injury in any manner during placing and curing, and shall replace such work at his expense.

Retempering of concrete by adding water or any other material shall not be permitted.

The rate of delivery of concrete to the job shall be sufficient to allow uninterrupted placement of the concrete.

**610-3.9 FORMS.** Concrete shall not be placed until all the forms and reinforcements have been inspected and approved by the DEN Project Manager. Forms shall be of suitable material and shall be of the type, size, shape, quality, and strength to build the structure as shown on the plans. The forms shall be true to line and grade and shall be mortar-tight and sufficiently rigid to prevent displacement and sagging between supports. The surfaces of forms shall be smooth and free from irregularities, dents, sags, and holes. The Contractor shall be responsible for their adequacy.

The internal form ties shall be arranged so no metal will show in the concrete surface or discolor the surface when exposed to weathering when the forms are removed. All forms shall be wetted with water or with a non-staining mineral oil, which shall be applied immediately before the concrete is placed. Forms shall be constructed so they can be removed without injuring the concrete or concrete surface. The forms shall not be removed until at least 30 hours after concrete placement for vertical faces, walls, slender columns, and similar structures. Forms supported by falsework under slabs, beams, girders, arches, and similar construction shall not be removed until tests indicate the concrete has developed at least 60% of the design strength.

**610-3.10 PLACING REINFORCEMENT.** All reinforcement shall be accurately placed, as shown on the plans, and shall be firmly held in position during concrete placement. Bars shall be fastened together at intersections. The reinforcement shall be supported by approved metal chairs. Shop drawings, lists, and bending details shall be supplied by the Contractor when required.

**610-3.11 EMBEDDED ITEMS.** Before placing concrete, all embedded items shall be firmly and securely fastened in place as indicated. All embedded items shall be clean and free from coating, rust, scale, oil, or any foreign matter. The concrete shall be spaded and consolidated around and against embedded items. The embedding of wood shall not be allowed.

**610-3.12 PLACING CONCRETE.** All concrete shall be placed during daylight hours, unless otherwise approved. The concrete shall not be placed until the depth and condition of foundations, the adequacy of forms and falsework, and the placing of the steel reinforcing have been approved by the DEN Project Manager. Concrete shall be placed as soon as



practical after mixing, but in no case later than one (1) hour after water has been added to the mix. The method and manner of placing shall avoid segregation and displacement of the reinforcement. Troughs, pipes, and chutes shall be used as an aid in placing concrete when necessary. The concrete shall not be dropped from a height of more than 5 feet (1.5 m). Concrete shall be deposited as nearly as practical in its final position to avoid segregation due to rehandling or flowing. Do not subject concrete to procedures which cause segregation. Concrete shall be placed on clean, damp surfaces, free from running water, or on a properly consolidated soil foundation.

**610-3.13 VIBRATION.** Vibration shall follow the guidelines in American Concrete Institute (ACI) Committee 309, Guide for Consolidation of Concrete. Where bars meeting ASTM A775 or A934 are used, the vibrators shall be equipped with rubber or non-metallic vibrator heads. Furnish a spare, working, vibrator on the job site whenever concrete is placed. Consolidate concrete slabs greater than 4 inches (100 mm) in depth with high frequency mechanical vibrating equipment supplemented by hand spading and tamping. Consolidate concrete slabs 4 inches (100 mm) or less in depth by wood tampers, spading, and settling with a heavy leveling straightedge. Operate internal vibrators with vibratory element submerged in the concrete, with a minimum frequency of not less than 6000 cycles per minute when submerged. Do not use vibrators to transport the concrete in the forms. Penetrate the previously placed lift with the vibrator when more than one lift is required. Use external vibrators on the exterior surface of the forms when internal vibrators do not provide adequate consolidation of the concrete. Vibrators shall be manipulated to work the concrete thoroughly around the reinforcement and embedded fixtures and into corners and angles of the forms. The vibration at any point shall be of sufficient duration to accomplish compaction but shall not be prolonged to where segregation occurs. Concrete deposited under water shall be carefully placed in a compact mass in its final position by means of a tremie or other approved method and shall not be disturbed after placement.

**610-3.14 CONSTRUCTION JOINTS.** If the placement of concrete is suspended, necessary provisions shall be made for joining future work before the placed concrete takes its initial set. For the proper bonding of old and new concrete, provisions shall be made for grooves, steps, reinforcing bars or other devices as specified. The work shall be arranged so that a section begun on any day shall be finished during daylight of the same day. Before depositing new concrete on or against concrete that has hardened, the surface of the hardened concrete shall be cleaned by a heavy steel broom, roughened slightly, wetted, and covered with a neat coating of cement paste or grout.

**610-3.15 EXPANSION JOINTS.** Expansion joints shall be constructed at such points and dimensions as indicated on the drawings. The premolded filler shall be cut to the same shape as the surfaces being joined. The filler shall be fixed firmly against the surface of the concrete already in place so that it will not be displaced when concrete is deposited against it.

**610-3.16 DEFECTIVE WORK.** Any defective work discovered after the forms have been removed, which in the opinion of the DEN Project Manager cannot be repaired satisfactorily, shall be immediately removed and replaced at the expense of the Contractor.

Defective work shall include deficient dimensions, or bulged, uneven, or honeycomb on the surface of the concrete.

**610-3.17 SURFACE FINISH.** All exposed concrete surfaces shall be true, smooth, and free from open or rough areas, depressions, or projections. All concrete horizontal plane surfaces shall be brought flush to the proper elevation with the finished top surface struck-off with a straightedge and floated. Mortar finishing shall not be permitted, nor shall dry cement or sand-cement mortar be spread over the concrete during the finishing of horizontal plane surfaces.

The surface finish of exposed concrete shall be a rubbed finish. If forms can be removed while the concrete is still green, the surface shall be wetted and then rubbed with a wooden float until all irregularities are removed. If the concrete has hardened before being rubbed, a carborundum stone shall be used to finish the surface. When approved, the finishing can be done with a finishing machine.

**610-3.18 CURING AND PROTECTION.** All concrete shall be properly cured and protected by the Contractor. The concrete shall be protected from the weather, flowing water, and from defacement of any nature during the project. The concrete shall be cured by covering with an approved material as soon as it has sufficiently hardened. Water-absorptive coverings shall be thoroughly saturated when placed and kept saturated for at least three (3) days following concrete placement. All curing mats or blankets shall be sufficiently weighted or tied down to keep the concrete surface covered and to prevent the surface from being exposed to air currents. Wooden forms shall be kept wet at all times until removed to prevent opening of joints and drying out of the concrete. Traffic shall not be allowed on concrete surfaces for seven (7) days after the concrete has been placed.

**610-3.19 DRAINS OR DUCTS.** Drainage pipes, conduits, and ducts that are to be encased in concrete shall be installed by the Contractor before the concrete is placed. The pipe shall be held rigidly so that it will not be displaced or moved during the placing of the concrete.

**610-3.20 COLD WEATHER PROTECTION.** When concrete is placed at temperatures below 40°F (4°C), the Contractor shall provide satisfactory methods and means to protect the mix from injury by freezing. The aggregates, or water, or both, shall be heated to place the concrete at temperatures between 50°F and 100°F (10°C and 38°C).

Calcium chloride may be incorporated in the mixing water when directed by the DEN Project Manager. Not more than 2 pounds (908 grams) of Type 1 nor more than 1.6 pounds (726 grams) of Type 2 shall be added per bag of cement. After the concrete has been placed, the Contractor shall provide sufficient protection such as cover, canvas, framework, heating apparatus, etc., to enclose and protect the structure and maintain the temperature of the mix at not less than 50°F (10°C) until at least 60% of the designed strength has been attained.

**610-3.21 HOT WEATHER PLACING.** Concrete shall be properly placed and finished with procedures previously submitted. The concrete-placing temperature shall not exceed 100°F (38°C) when measured in accordance with ASTM C1064. Cooling of the

mixing water and aggregates, or both, may be required to obtain an adequate placing temperature. A retarder meeting the requirements of paragraph 610-2.6 may be used to facilitate placing and finishing. Steel forms and reinforcement shall be cooled prior to concrete placement when steel temperatures are greater than 120°F (50°C). Conveying and placing equipment shall be cooled if necessary to maintain proper concrete-placing temperature. Submit the proposed materials and methods for review and approval by the DEN Project Manager, if concrete is to be placed under hot weather conditions.

**610-3.22 FILLING JOINTS.** All joints that require filling shall be thoroughly cleaned, and any excess mortar or concrete shall be cut out with proper tools. Joint filling shall not start until after final curing and shall be done only when the concrete is completely dry. The cleaning and filling shall be done with proper equipment to obtain a neat looking joint free from excess filler.

### METHOD OF MEASUREMENT

**610-4.1** In general, and unless listed in the proposal as a separate payment item, structural concrete will not be measured for payment, but shall be incidental to those proposed items in which concrete is a component part.

**610-4.2** Concrete Pavement (Fiber-Reinforced, 6”) shall be measured per square yard in place and accepted. No measurement or other allowances shall be made for forms, falsework, pumping, bracing, expansion joints, finishing of the concrete, or other incidentals.

### BASIS OF PAYMENT

**610-5.1** Structural concrete shall be considered incidental to the project. No payment shall be made for structural concrete, unless listed in the proposal as a separate payment item.

**610-5.2** Concrete Pavement (Fiber-Reinforced, 6”) shall be made at the contract unit price per square yard. This price shall be full compensation for furnishing all labor, material, equipment, tools, and incidentals necessary to complete the item.

Payment will be made under:

Item P-610a Concrete Pavement (6” Fiber-Reinforced) – per square yard

### TESTING REQUIREMENTS

ASTM C31 Standard Practice for Making and Curing Concrete Test Specimens in the Field

ASTM C39 Standard Test Method for Compressive Strength of Cylindrical Concrete Specimens

ASTM C136 Standard Test Method for Sieve or Screen Analysis of Fine and Coarse Aggregates

|  |   |
|--|---|
| ASTM C138  | Standard Test Method for Density (Unit Weight), Yield, and Air Content (Gravimetric) of Concrete  |
| ASTM C143  | Standard Test Method for Slump of Hydraulic-Cement Concrete   |
| ASTM C231  | Standard Test Method for Air Content of Freshly Mixed Concrete by the Pressure Method   |
| ASTM C666  | Standard Test Method for Resistance of Concrete to Rapid Freezing and Thawing   |
| ASTM C1017   | Standard Specification for Chemical Admixtures for Use in Producing Flowing Concrete  |
| ASTM C1064   | Standard Test Method for Temperature of Freshly Mixed Hydraulic-Cement Concrete   |
| ASTM C1077   | Standard Practice for Agencies Testing Concrete and Concrete Aggregates for Use in Construction and Criteria for Testing Agency Evaluation                            |
| ASTM C1260   | Standard Test Method for Potential Alkali Reactivity of Aggregates (Mortar-Bar Method)  |
| ASTM C1567   | Standard Test Method for Determining the Potential Alkali-Silica Reactivity of Combinations of Cementitious Materials and Aggregates (Accelerated Mortar-Bar Method)  |
| ASTM E329  | Standard Specification for Agencies Engaged in Construction Inspection, Testing, or Special Inspection  |
| U.S. Army Corps of Engineers (USACE) Concrete Research Division (CRD) C662 | Determining the Potential Alkali-Silica Reactivity of Combinations of Cementitious Materials, Lithium Nitrate Admixture and Aggregate (Accelerated Mortar-Bar Method) |

### **MATERIAL REQUIREMENTS**

|           |   |
|-----------|---|
| ASTM A184 | Standard Specification for Welded Deformed Steel Bar Mats for Concrete Reinforcement          |
| ASTM A185 | Standard Specification for Steel Welded Wire Reinforcement, Plain, for Concrete               |
| ASTM A615 | Standard Specification for Deformed and Plain Carbon-Steel Bars for Concrete Reinforcement    |
| ASTM A704 | Standard Specification for Welded Steel Plain Bar or Rod Mats for Concrete Reinforcement      |
| ASTM A706 | Standard Specification for Low-Alloy Steel Deformed and Plain Bars for Concrete Reinforcement |
| ASTM A775 | Standard Specification for Epoxy-Coated Steel Reinforcing Bars                                |

|            |  |
|------------|--|
| ASTM A934  | Standard Specification for Epoxy-Coated Prefabricated Steel Reinforcing Bars   |
| ASTM A1064 | Standard Specification for Carbon-Steel Wire and Welded Wire Reinforcement, Plain and Deformed, for Concrete   |
| ASTM C33   | Standard Specification for Concrete Aggregates   |
| ASTM C94   | Standard Specification for Ready-Mixed Concrete  |
| ASTM C150  | Standard Specification for Portland Cement   |
| ASTM C171  | Standard Specification for Sheet Materials for Curing Concrete   |
| ASTM C172  | Standard Practice for Sampling Freshly Mixed Concrete  |
| ASTM C260  | Standard Specification for Air-Entraining Admixtures for Concrete  |
| ASTM C309  | Standard Specification for Liquid Membrane-Forming Compounds for Curing Concrete   |
| ASTM C494  | Standard Specification for Chemical Admixtures for Concrete  |
| ASTM C595  | Standard Specification for Blended Hydraulic Cements   |
| ASTM C618  | Standard Specification for Coal Fly Ash and Raw or Calcined Natural Pozzolan for Use in Concrete   |
| ASTM D1751 | Standard Specification for Preformed Expansion Joint Filler for Concrete Paving and Structural Construction (Nonextruding and Resilient Asphalt Types) |
| ASTM D1752 | Standard Specification for Preformed Sponge Rubber Cork and Recycled PVC Expansion Joint Fillers for Concrete Paving and Structural Construction       |
| ACI 305R   | Hot Weather Concreting   |
| ACI 306R   | Cold Weather Concreting  |
| ACI 309R   | Guide for Consolidation of Concrete  |

**END OF ITEM P-610**

**ITEM T-901 SEEDING**

**DESCRIPTION**

**901-1.1** This item shall consist of soil preparation, seeding, and fertilizing the areas shown on the plans or as directed by the DEN Project Manager in accordance with these specifications.

**MATERIALS**

**901-2.1 SEED** The species and application rates of grass, legume, and cover-crop seed furnished shall be those stipulated herein. Seed shall conform to the requirements of Federal Specification JJJ-S-181, Federal Specification, Seeds, Agricultural.

Seed shall be furnished separately or in mixtures in standard containers labeled in conformance with the Agricultural Marketing Service (AMS) Seed Act and applicable state seed laws with the seed name, lot number, net weight, percentages of purity and of germination and hard seed, and percentage of maximum weed seed content clearly marked for each kind of seed. The Contractor shall furnish the DEN Project Manager duplicate signed copies of a statement by the vendor certifying that each lot of seed has been tested by a recognized laboratory for seed testing within six (6) months of date of delivery. This statement shall include: name and address of laboratory, date of test, lot number for each kind of seed, and the results of tests as to name, percentages of purity and of germination, and percentage of weed content for each kind of seed furnished, and, in case of a mixture, the proportions of each kind of seed. Wet, moldy, or otherwise damaged seed will be rejected.

Seeds shall be applied as follows:

**Mix Design 2 - Non-saline Upland Seed Mix For Shoulder Areas**

| Scientific Name               | Common Name      | Variety      | lbs PLS /acre* | % of mix** |
|-------------------------------|------------------|--------------|----------------|------------|
| <b>GRASSES</b>                |                  |              |                |            |
| Bouteloua curtipendula        | Sideoats Grama   | Vaughn       | 0.8            | 10         |
| Bouteloua gracilis            | Blue Grama       | Bad River    | 0.05           | 2.5        |
| Bouteloua gracilis            | Blue Grama       | Hachita      | 0.05           | 2.5        |
| Buchloe dactyloides           | Buffalograss     | Cody         | 0.7            | 2.5        |
| Buchloe dactyloides           | Buffalograss     | Native -VNS† | 0.7            | 2.5        |
| Distichlis spicata v. stricta | Inland Saltgrass | Native -VNS† | 0.3            | 5          |

|                                    |                       |              |             |            |
|------------------------------------|-----------------------|--------------|-------------|------------|
| Elymus lanceolatus v. lanceolatus  | Thickspike Wheatgrass | Critana      | 1.1         | 11         |
| Elymus lanceolatus v. psammophilus | Streambank Wheatgrass | Sodar        | 1.0         | 10         |
| Elymus trachycaulus                | Slender Wheatgrass    | Primar0.5    | 0.5         | 5          |
| Nasella viridula                   | Green Needlegrass     | LoDorm       | 0.8         | 5          |
| Pascopyrum smithii                 | Western Wheatgrass    | Arriba       | 3.6         | 25         |
| Poa secunda                        | Sandberg Bluegrass    | Native -VNS† | 0.5         | 5          |
| Sporobolus cryptandrus             | Sand Dropseed         | Native -VNS† | 0.01        | 4          |
| Stipa comata                       | Needleandthread Grass | Native -VNS† | 0.7         | 5          |
| Grass species subtotal             |                       |              | 10.8        | 100        |
| <b>TOTAL PLS RATE</b>              |                       |              | <b>10.8</b> | <b>100</b> |

\* PLS means Pure Live Seed; rates shown are for drill seeding, if broadcast, rates should be doubled.

\*\* Percent by seed number

\*\*\* Wetland mixes to be used only where wetland hydrology exists. Check with DIA Environmental Services.

† VNS = Variety Not Stated

Seeding shall be performed during the period between spring thaw and July 1 or between October 15 and the freezing of the ground.

**901-2.2 FERTILIZER.** Fertilizer shall be standard commercial fertilizers supplied separately or in mixtures containing the percentages of total nitrogen, available phosphoric acid, and water-soluble potash. They shall be applied at the rate and to the depth specified, and shall meet the requirements of applicable state laws. They shall be furnished in standard containers with name, weight, and guaranteed analysis of contents clearly marked thereon. No cyanamide compounds or hydrated lime shall be permitted in mixed fertilizers.

The fertilizers may be supplied in one of the following forms:

- a. A dry, free-flowing fertilizer suitable for application by a common fertilizer spreader;
- b. A finely-ground fertilizer soluble in water, suitable for application by power sprayers; or
- c. A granular or pellet form suitable for application by blower equipment.

Fertilizers shall be a commercial fertilizer and shall be spread at the rate which is determined by the seeding contractor to allow for proper vegetative growth.

**901-2.3 SOIL FOR REPAIRS.** The soil for fill and topsoiling of areas to be repaired shall be at least of equal quality to that which exists in areas adjacent to the area to be repaired. The soil shall be relatively free from large stones, roots, stumps, or other materials that will interfere with subsequent sowing of seed, compacting, and establishing turf, and shall be approved by the DEN Project Manager before being placed.

### CONSTRUCTION METHODS

**901-3.1 ADVANCE PREPARATION AND CLEANUP.** After grading of areas has been completed and before applying fertilizer and ground limestone, areas to be seeded shall be raked or otherwise cleared of stones larger than 2 inches (50 mm) in any diameter, sticks, stumps, and other debris that might interfere with sowing of seed, growth of grasses, or subsequent maintenance of grass-covered areas. If any damage by erosion or other causes has occurred after the completion of grading and before beginning the application of fertilizer and ground limestone, the Contractor shall repair such damage include filling gullies, smoothing irregularities, and repairing other incidental damage.

An area to be seeded shall be considered a satisfactory seedbed without additional treatment if it has recently been thoroughly loosened and worked to a depth of not less than 5 inches (125 mm) as a result of grading operations and, if immediately prior to seeding, the top 3 inches (75 mm) of soil is loose, friable, reasonably free from large clods, rocks, large roots, or other undesirable matter, and if shaped to the required grade.

When the area to be seeded is sparsely sodded, weedy, barren and unworked, or packed and hard, any grass and weeds shall first be cut or otherwise satisfactorily disposed of, and the soil then scarified or otherwise loosened to a depth not less than 5 inches (125 mm). Clods shall be broken and the top 3 inches (75 mm) of soil shall be worked into a satisfactory seedbed by discing, or by use of cultipackers, rollers, drags, harrows, or other appropriate means.

**901-3.2 SEEDING.** Seeding shall be accomplished by drill seeding or by broadcast seeding.

If drill seeding is used, the seed drill will be equipped with three seed boxes including one for large smooth seed, one for fluffy seed (with picker wheels to prevent bridging), and one for small smooth seed. Furrow spacing may vary between 7 and 9 inches (175 to 225 mm). Drill will have double disc furrow openers and functioning depth bands set to plant at ½ inch (12 mm) depth. Drill will have either packer wheels or drag chains. Grain drills are NOT acceptable. Seeder-cultipackers are also not acceptable.

If broadcast seeding is used, soil surface will be roughened IMMEDIATELY prior to seeding using a toothed-type harrow. Seed will be spread by hand or by cyclonic spreader at a rate TWICE that specified for drill seeding in Tables 901-1 and 901-2. Immediately following seeding, the treated area will be harrowed with a tooth-type harrow to cover the seed. Sufficient passes will be made to assure that seed is covered to a depth of at least ¼ inch. Brush or chain-link drags are not acceptable for this purpose.



**901-3.3 MAINTENANCE OF SEEDED AREAS.** The Contractor shall protect seeded areas against traffic or other use by warning signs or barricades, as approved by the DEN Project Manager. Surfaces gullied or otherwise damaged following seeding shall be repaired by regrading and reseeding as directed. The Contractor shall mow, water as directed, and otherwise maintain seeded areas in a satisfactory condition until final inspection and acceptance of the work.

When either the dry or wet application method outlined above is used for work done out of season, it will be required that the Contractor establish a good stand of grass of uniform color and density to the satisfaction of the DEN Project Manager. A grass stand shall be considered adequate when bare spots are one square foot (0.01 sq m) or less, randomly dispersed, and do not exceed 3% of the area seeded.

Alternatively, a two-year warranty period may be established after which re-vegetation requirements associated with construction projects as regulated by the National Pollutant Discharge Elimination System (NPDES) stormwater program and managed by the Colorado Department of Public Health and Environment (CDPHE) would be implemented. Permanent stabilization is defined by CDPHE and in this specification as return of ground cover (cover of live plants including weeds plus that of litter (detached dead plant parts) and standing dead plant material) equal to or greater than 70% of that present previous to disturbance. Inasmuch as total ground cover in this area prior to disturbance is often in the range of 70 to 80%, meaning that 70% of these levels is about 50 to 55%, a single standard of 50% total ground cover will be used. That is, to be regarded as stabilized, project areas must demonstrate 50% ground cover (by visual estimate). In other words no more than 50% of the surface may be exposed soil. Areas with bare soil in excess of 50% may be no larger than 1000 sq.ft. as determined by the DEN Project Manager.

If, at the time when the contract has been otherwise completed it is not possible to make a determination of the adequacy of the re-vegetation, payment for the unaccepted portions of the areas will be withheld until such time as these requirements have been met.

#### **METHOD OF MEASUREMENT**

**901-4.1** The quantity of seeding to be paid for shall be the number of units acre (sq m) measured on the ground surface, completed and accepted.

#### **BASIS OF PAYMENT**

**901-5.1** **901-5.1** Payment shall be made at the contract unit price per acre (sq m) or fraction thereof, which price and payment shall be full compensation for furnishing and placing all material and for all labor, equipment, tools, and incidentals necessary to complete the work prescribed in this item.

Payment will be made under:

Item T-901a                      Seeding (Seed Mix Design 2) – per acre

## MATERIAL REQUIREMENTS

|           |  |
|-----------|--|
| ASTM C602 | Standard Specification for Agricultural Liming Materials |
| ASTM D977 | Standard Specification for Emulsified Asphalt            |
| FED SPEC  | JJJ-S-181, Federal Specification, Seeds, Agricultural    |

## ATTACHMENT 901-A NOXIOUS WEED SPECIES AS PER COLORADO WEED ACT

### LIST A NOXIOUS WEED SPECIES

African rue (*Peganum harmala*)  
Camelthorn (*Alhagi pseudalhagi*)  
Common crupina (*Crupina vulgaris*)  
Cypress spurge (*Euphorbia cyparissias*)  
Dyer's woad (*Isatis tinctoria*)  
Giant salvinia (*Salvinia molesta*)  
Hydrilla (*Hydrilla verticillata*)  
Meadow knapweed (*Centaurea pratensis*)  
Mediterranean sage (*Salvia aethiopis*)  
Medusahead (*Taeniatherum caput-medusae*)  
Myrtle spurge (*Euphorbia myrsinites*)  
Purple loosestrife (*Lythrum salicaria*)  
Rush skeletonweed (*Chondrilla juncea*)  
Sericea lespedeza (*Lespedeza cuneata*)  
Squarrose knapweed (*Centaurea virgata*)  
Tansy ragwort (*Senecio jacobaea*)  
Yellow starthistle (*Centaurea solstitialis*)

### LIST B NOXIOUS WEED SPECIES

Absinth wormwood (*Artemisia absinthium*)  
Black henbane (*Hyoscyamus niger*)  
Bouncingbet (*Saponaria officinalis*)  
Bull thistle (*Cirsium vulgare*)  
Canada thistle (*Cirsium arvense*)  
Chinese clematis (*Clematis orientalis*)

Common tansy (*Tanacetum vulgare*)  
Common teasel (*Dipsacus fullonum*)  
Corn chamomile (*Anthemis arvensis*)  
Cutleaf teasel (*Dipsacus laciniatus*)  
Dalmatian toadflax, broad-leaved (*Linaria dalmatica*)  
Dalmatian toadflax, narrow-leaved (*Linaria genistifolia*)  
Dame's rocket (*Hesperis matronalis*)  
Diffuse knapweed (*Centaurea diffusa*)  
Eurasian watermilfoil (*Myriophyllum spicatum*)  
Hoary cress (*Cardaria draba*)  
Houndstongue (*Cynoglossum officinale*)  
Leafy spurge (*Euphorbia esula*)  
Mayweed chamomile (*Anthemis cotula*)  
Moth mullein (*Verbascum blattaria*)  
Musk thistle (*Carduus nutans*)  
Orange hawkweed (*Hieracium aurantiacum*)  
Oxeye daisy (*Chrysanthemum leucanthemum*)  
Perennial pepperweed (*Lepidium latifolium*)  
Plumeless thistle (*Carduus acanthoides*)  
Quackgrass (*Elytrigia repens*)  
Redstem filaree (*Erodium cicutarium*)  
Russian knapweed (*Acroptilon repens*)  
Russian-olive (*Elaeagnus angustifolia*)  
Salt cedar (*Tamarix chinensis*, *T. parviflora*, and *T. ramosissima*)  
Scentless chamomile (*Matricaria perforata*)  
Scotch thistle (*Onopordum acanthium*)  
Scotch thistle (*Onopordum tauricum*)  
Spotted knapweed (*Centaurea maculosa*)  
Spurred anoda (*Anoda cristata*)  
Sulfur cinquefoil (*Potentilla recta*)  
Venice mallow (*Hibiscus trionum*)  
Wild caraway (*Carum carvi*)  
Yellow nutsedge (*Cyperus esculentus*)

Yellow toadflax (*Linaria vulgaris*)

**LIST C NOXIOUS WEED SPECIES**

Chicory (*Cichorium intybus*)

Common burdock (*Arctium minus*)

Common mullein (*Verbascum thapsus*)

Common St. Johnswort (*Hypericum perforatum*)

Downy brome (*Bromus tectorum*)

Field bindweed (*Convolvulus arvensis*)

Halogeton (*Halogeton glomeratus*)

Johnsongrass (*Sorghum halepense*)

Jointed goatgrass (*Aegilops cylindrica*)

Perennial sowthistle (*Sonchus arvensis*)

Poison hemlock (*Conium maculatum*)

Puncturevine (*Tribulus terrestris*)

Velvetleaf (*Abutilon theophrasti*)

Wild proso millet (*Panicum miliaceum*)

**END OF ITEM T-901**



## ITEM T-905 TOPSOILING

### DESCRIPTION

**905-1.1** This item shall consist of preparing the ground surface for topsoil application, removing topsoil from designated stockpiles or areas to be stripped on the site or from approved sources off the site, and placing and spreading the topsoil on prepared areas in accordance with this specification at the locations shown on the plans or as directed by the DEN Project Manager.

### MATERIALS

**905-2.1 TOPSOIL.** Topsoil shall be the surface layer of soil with no admixture of refuse or any material toxic to plant growth, and it shall be reasonably free from subsoil and stumps, roots, brush, stones (2 inches (50 mm) or more in diameter), and clay lumps or similar objects. Brush and other vegetation that will not be incorporated with the soil during handling operations shall be cut and removed. Ordinary sod and herbaceous growth such as grass and weeds are not to be removed, but shall be thoroughly broken up and intermixed with the soil during handling operations. Heavy sod or other cover, which cannot be incorporated into the topsoil by discing or other means, shall be removed. The topsoil or soil mixture, unless otherwise specified or approved, shall have a pH range of approximately 7.6 pH to 8.0 pH, when tested in accordance with the methods of testing of the Association of Official Agricultural Chemists in effect on the date of invitation of bids. The organic content shall be not less than 1% nor more than 10% as determined by the wet-combustion method (chromic acid reduction). Soil textures (USDA) suitable for re-vegetation include Sandy Loam, Loam, Silt Loam, Clay Loam, Sandy Clay Loam, Silty Clay Loam, and Loamy Sand.

When topsoil is imported to the site, it shall meet the following criteria:

| Parameter                    | Acceptable  | Unacceptable                                    |
|------------------------------|---|---|
| <b>Texture</b>               | <b>Sandy Loam, Loam, Silt Loam, Clay Loam, Sandy Clay Loam, Silty Clay Loam, Loamy Sand</b> | <b>Silty Clay, Clay, Sandy Clay, Sand, Silt</b> |
| Soil Reaction                | pH 5.0 to 8.0   | < 5.0 or > 8.0                                  |
| Salinity (mmhos/cm)          | < or = 4.0  | > 4.0   |
| Organic Matter (%)           | > or = 1.0  | < 1.0   |
| Coarse Fragment Content (%)* | < or = 20   | > 20  |

\* Percent by weight of particles > 2 mm diameter (ie. gravels; cobbles and boulders excluded by provisions of 901-3.2)

Natural topsoil may be amended by the Contractor with approved materials and methods to meet the above specifications.

**905-2.2 INSPECTION AND TESTS.** Within 10 days following acceptance of the bid, the DEN Project Manager shall be notified of the source of topsoil to be furnished by the Contractor. The topsoil shall be inspected to determine if the selected soil meets the requirements specified and to determine the depth to which stripping will be permitted. At this time, the Contractor may be required to take representative soil samples from several locations within the area under consideration and to the proposed stripping depths, for testing purposes as specified in paragraph 905-2.1.

### CONSTRUCTION METHODS

**905-3.1 GENERAL.** Areas to be topsoiled shall be shown on the plans. If topsoil is available on the site, the location of the stockpiles or areas to be stripped of topsoil and the stripping depths shall be shown on the plans.

Suitable equipment necessary for proper preparation and treatment of the ground surface, stripping of topsoil, and for the handling and placing of all required materials shall be on hand, in good condition, and approved by the DEN Project Manager before the various operations are started.

**905-3.2 PREPARING THE GROUND SURFACE.** Immediately prior to dumping and spreading the topsoil on any area, the surface shall be loosened by discs or spike-tooth harrows, or by other means approved by the DEN Project Manager, to a minimum depth of 18 inches (45 cm) minus the specified depth of the topsoil. *If, for example, the topsoil depth is six inches (as would be typical) the ripping need only go to 12 inches (30 cm).* In FAA determined safety areas on the shoulders of taxiways, runways or ramps where only 6 inches of ripping is allowed, the total depth of loosened material including topsoil will be 6 inches.

The surface of the area to be topsoiled shall be cleared of all stones larger than 2 inches (50 mm) in any diameter and all litter or other material which may be detrimental to proper bonding, the rise of capillary moisture, or the proper growth of the desired planting. Limited areas, as shown on the plans, which are too compact to respond to these operations shall receive special scarification.

Grades on the area to be topsoiled, which have been established by others as shown on the plans, shall be maintained in a true and even condition. Where grades have not been established, the areas shall be smooth-graded and the surface left at the prescribed grades in an even and compacted condition to prevent the formation of low places or pockets where water will stand.

**905-3.3 OBTAINING TOPSOIL.** Prior to the stripping of topsoil from designated areas, any vegetation, briars, stumps and large roots, rubbish or stones found on such areas,

which may interfere with subsequent operations, shall be removed using methods approved by the DEN Project Manager. Heavy sod or other cover, which cannot be incorporated into the topsoil by discing or other means shall be removed.

When suitable topsoil is available on the site, the Contractor shall remove this material from the designated areas and to the depth as directed by the DEN Project Manager. The topsoil shall be spread on areas already tilled and smooth-graded, or stockpiled in areas approved by the DEN Project Manager. Any topsoil stockpiled by the Contractor shall be rehandled and placed without additional compensation. Any topsoil that has been stockpiled on the site by others, and is required for topsoiling purposes, shall be removed and placed by the Contractor. The sites of all stockpiles and areas adjacent thereto which have been disturbed by the Contractor shall be graded if required and put into a condition acceptable for seeding.

When suitable topsoil is secured off the airport site, the Contractor shall locate and obtain the supply, subject to the approval of the DEN Project Manager. The Contractor shall notify the DEN Project Manager sufficiently in advance of operations in order that necessary measurements and tests can be made. The Contractor shall remove the topsoil from approved areas and to the depth as directed. The topsoil shall be hauled to the site of the work and placed for spreading, or spread as required. Any topsoil hauled to the site of the work and stockpiled shall be rehandled and placed without additional compensation.

**a. Topsoil Amendments.** If topsoil is unavailable or of such poor quality that available materials need supplementary organic matter, then soil amendments shall be used. The soil amendment shall consist of composted biosolids or composted manure, or other organic soil amendment product approved by the Project Manager.

Organic amendment comprised of composted biosolids shall comply with all requirements of U.S. EPA's biosolids regulations.

Organic amendment comprised of composted manure shall be produced as follows:

- (1) Compost organic amendment (cow or sheep manure) for 90 to 120 days. Certification must be provided to prove the product has gone through this process.
- (2) Eradicate harmful pathogens including coliform bacteria.
- (3) Create a carbon to nitrogen ratio of 15:1 to 25:1.
- (4) Contain no solid particle greater than ½ inch diameter.
- (5) Have a non-offensive smell similar to fresh turned soil.
- (6) Contain no significant level of dirt, soil, or chemical preservatives and contain a maximum of 30 percent composted plant residue.
- (7) Have a Ph after composting between 6 and 8 with an organic matter content of at least 20 percent.



- (8) Contain soluble salts not greater than 5mmhos/cm.
- (9) Produced by aerobic decomposition.
- (10) Processed at a consistent temperature of 140 degrees F or greater.

A Certificate of Compliance shall be provided to the Project Manager to verify the organic matter content, Ph, and carbon matter to nitrogen ratio, and salt levels (by electrical conductivity mmhos/cm).

If organic amendment is not available, a natural trace mineral, carbon, and humic acid based granular soil conditioner may be used (such as Menefee Humate, or approved equal).

The proposed soil amendment shall be submitted to the Project Manager for his work approval as a part of the Common Excavation Plan. The soil amendment plan shall be based on soil samples obtained from the topsoil removed and stockpiled and shall be formulated to develop a suitable seed bed at least as suitable as those areas where topsoil is placed.

**b. Topsoil Plan.** The Contractor shall prepare a Topsoil Plan which shall include but not be limited to the following items:

- (1) Location and quantity of topsoil stockpiles available for the project.
- (2) Location and quantity of topsoil available from borrow areas.
- (3) Location and quantity of topsoil required for all areas to be topsoiled within project limits.
- (4) Identification of and plan for removal of all undesirable materials such as weeds, trash, debris, etc., before actual stripping commences.
- (5) Haul routes, schedules, utility conflicts, and other Topsoil Plan features by the Project Manager.

**905-3.4 STOCKPILING.** Stockpiled side slopes shall not exceed 3:1. All stockpiles and adjacent areas that have been disturbed by the Contractor shall be graded, topsoiled if necessary, ripped and seeded in accordance with Sections T-901 and T-908. Whenever it is practical, topsoil shall be hauled directly from the salvage site to the placement site to avoid double handling.

A sufficient amount of topsoil for the entire project including shrinkage and waste shall be set aside before any quality topsoil material is used for purposes other than topsoiling.

**905-3.5 PLACING TOPSOIL.** The topsoil shall be evenly spread on the prepared areas that have been left roughened to prevent topsoil layer slippage. Topsoil shall be placed to an average depth of six (6) inches, where the subsoil is suitable according to the following.

Subsoil Suitability criteria are as follows:

| Parameter           | Acceptable    | Unacceptable  |
|---------------------|---------------|---------------|
| Soil Reaction       | pH 5.0 to 8.7 | < 5.0 or >8.7 |
| Salinity (mmhos/cm) | < or = 7.0    | > 7.0         |

Where the subsoil does not meet the above suitability criteria, then the topsoil depth shall be 15 inches, or the Contractor shall apply soil amendments in order to bring brine soils within acceptance criteria.

Spreading shall not be done when the ground or topsoil is frozen, excessively wet, or otherwise in a condition detrimental to the work. Spreading shall be carried on so that turving operations can proceed with a minimum of soil preparation or tilling.

After spreading, any large, stiff clods and hard lumps shall be broken with a pulverizer or by other effective means, and all stones or rocks (2 inches (50 mm) or more in diameter), roots, litter, or any foreign matter shall be raked up and disposed of by the Contractor. After spreading is completed, the topsoil shall be satisfactorily compacted by rolling with a cultipacker or by other means approved by the DEN Project Manager. The compacted topsoil surface shall conform to the required lines, grades, and cross-sections. Any topsoil or other dirt falling upon pavements as a result of hauling or handling of topsoil shall be promptly removed.

**905-3.6 VERIFICATION OF TOPSOIL THICKNESS.** The contractor shall be required to provide depth measurements for every 5,000 square yards of topsoil placed to minimum of 6 inch depth of topsoil. To test the depth of topsoil, the redressed areas will be divided into 10 acre plots. Within each plot, at least ten randomly selected locations will be sampled for topsoil depth before seedbed preparation. More than 90% of the samples must have a depth equal to or greater than the specified design depth. If this criterion is not met, the contractor will redress the plot. Topsoil shall be added as necessary to provide and maintain the minimum 6 inches of topsoil through the contract and maintenance period.

**905-3.7 TOLERANCES.** The surface of the finished topsoil surface shall be of such smoothness that it will not vary more than plus 0.10' to minus 0.10' from true grade as shown on the Contract Drawings. Any deviation in excess of this amount shall be corrected by loosening, adding and removing materials, and reshaping.

### METHOD OF MEASUREMENT

**905-4.1** Topsoil obtained on or off the site will not be measured or paid for separately, but will be considered incidental to “Unclassified Excavation”.

### BASIS OF PAYMENT

**905-5.1** Topsoil (obtained on or off the site) will not be paid for separately, but will be considered incidental to “Unclassified Excavation”. This price shall be full compensation for furnishing all materials and for all preparation, placing, and spreading of the materials, and for all labor, equipment, tools, and incidentals necessary to complete the item.

**TESTING MATERIALS**

ASTM C117            Materials Finer than 75  $\mu\text{m}$  (No. 200) Sieve in Mineral Aggregates by  
Washing

**END OF ITEM T-905**

## ITEM T-908 MULCHING

### DESCRIPTION

**908-1.1** This item shall consist of furnishing, hauling, placing, and securing mulch on surfaces indicated on the plans or designated by the DEN Project Manager.

### MATERIALS

**908-2.1 MULCH MATERIAL.** Acceptable mulch shall be the materials listed below or any approved locally available material that is similar to those specified. Mulch shall be free from noxious weeds, mold, and other deleterious materials. Mulch materials, which contain matured seed of species that would volunteer and be detrimental to the proposed overseeding, or to surrounding farm land, will not be acceptable. Straw or other mulch material which is fresh and/or excessively brittle, or which is in such an advanced stage of decomposition as to smother or retard the planted grass, will not be acceptable.

**a. Wood-fiber Mulch.** Wood fiber mulch must be virgin long-fiber material. Wood fiber shall be absent of materials toxic to plant growth. Wood chips are not acceptable.

**b. Matting.**

(1) **Covering.** Covering shall consist of blankets with close weave mesh and nettings with open weave mesh made of various materials as specified herein.

(2) Blankets and nettings shall be biodegradable, non-toxic to vegetation or germination of seed, and shall not be toxic or injurious to humans.

(a) **Excelsior.** Excelsior soil retention covering shall be biodegradable as follows:

The blanket shall consist of a machine produced mat of curled wood excelsior of 80 percent, 6 inch or longer fiber length with a consistent thickness of fibers evenly distributed over the entire area of the blanket. The top side of the blanket shall be covered with a biodegradable netting, manufactured from a jute or other biodegradable material and stitched on 2 inch centers the entire width of the blanket.

Dimensions: 48" by 180' or 96" by 90'

Roll Weight: 0.9 to 1.1 pounds per sq. yd.

(b) **Soil Retention Blanket (Coconut).** Soil Retention Blanket (Coconut) shall be a machine produced mat consisting of 100 percent coconut fiber. The

blanket shall be of consistent thickness with the coconut fiber evenly distributed over the entire area of the mat. The blanket shall be sewn together with biodegradable thread.

Material requirements:

Coconut Fiber Content: 100%, 0.50 to 0.60 lb. per sq. yd  
Netting: Both sides, biodegradable 9.3 lbs. per 1000 sq. ft.  
Thread: Biodegradable  
Roll Width: 6.5 to 7.5 feet  
Roll Length: 83.5 to 110 feet  
Area Covered by One Roll: 60 to 80 sq. yds.

**(c) Soil Retention Blanket (Straw).** Soil Retention Blanket (Straw) shall be a machine produced mat consisting of 100 percent agricultural straw. The blanket shall be of consistent thickness with the straw evenly distributed over the entire area of the mat. The blanket shall be covered on the top side with biodegradable netting having an approximate 5/8 inch x 5/8 inch to 1/2 inch x 1/2 inch mesh and on the bottom with biodegradable netting with an approximate 1/4 inch x 1/4 inch to 1/2 inch x 1/2 inch mesh. The blanket shall be sewn together with biodegradable thread.

Material requirements:

Straw Content: 100%, 0.50 lb. per sq. yd.  
Netting: Bottom side biodegradable, 9. lbs. per 1000 sq. ft.;  
Netting: Top side biodegradable, 9.3 lbs. per 1000 sq. ft.  
Thread: Biodegradable  
Roll Width: 6.5 to 7.5 feet  
Roll Length: 83.5 to 110 feet  
Area Covered by One Roll: 60 to 80 sq. yds

A sample of the soil retention blanket (straw) shall be submitted at least 2 weeks in advance of its use on the project for approval by the Project Manager.

**(d) Soil Retention Blanket (Straw and Coconut).** Soil Retention Blanket (Straw/Coconut) shall be a machine produced mat consisting of 70 percent agricultural straw and 30 percent coconut fiber. The blanket shall be of consistent thickness with the straw and coconut fiber evenly distributed over the entire area of the mat. The blanket shall be covered on the top side with polypropylene netting having an approximate 5/8 inch x 5/8 inch mesh and on the bottom with polypropylene netting with an approximate 1/4 inch x 1/4 inch to 1/2 inch x 1/2 inch mesh. The blanket shall be sewn together with cotton, biodegradable or photodegradable thread.

Material requirements:

Straw Content: 70% 0.35 lb. per sq. yd.

Coconut Fiber Content: 30% 0.15 lb. per sq. yd.

Netting: Bottom side biodegradable, 9.3 lbs. per 1000 sq. ft.;

Netting: Top side biodegradable, 9.3 lbs. per 1000 sq. ft.

Thread: Cotton, biodegradable

Roll Width: 6.5 to 7.5 feet

Roll Length: 83.5 to 110 feet

Area Covered by One Roll: 60 to 80 sq. yds

A sample of the soil retention blanket (straw and coconut) shall be submitted at least 2 weeks in advance of its use on the project for approval by the Project Manager.

(3) Pins and Staples. Pins and staples shall be made of wire 0.162 inch or larger in diameter. “U” shaped staples shall have legs 8 inches long and a 1 inch crown. “T” shaped pins shall not be used

c. **Tackifier.** Material for mulch tackifier shall consist of a free-flowing, organic, 100% all natural starch polymer, applied in a slurry with water and wood fiber

d. **Stubble Mulch.** Stubble mulch is the holdover debris of stems and leaves left from a small grain crop; these can function as mulch for a permanent seeding. One of the crop species below is used to establish a cover and mulch that functions as a standing mulch for subsequent seeding. NOTE: when using these species, the crop must be mowed to product stubble prior to producing seed.

**Cover Crops for Use in Revegetation**

| Crop                                 | Date of crop planting  | Date of permanent cover seeding | Rate (lb PLS /ac) |
|--------------------------------------|------------------------|---------------------------------|-------------------|
| Wheat/Wheatgrass Hybrid (“ReGreen”™) | April 1 to May 15      | Next fall*                      | 35                |
|                                      | August 15 to October 1 |                                 | 35                |
| Oats                                 | April 1 to May 15      | Next fall                       | 30                |
| Winter Wheat/Triticale               | August 1 to October 1  | Next fall                       | 25                |
| Spring Barley                        | April 1 to May 15      | Next fall                       | 30                |
| Long-season (southern) Grain Sorghum | May 15 to July 15      | Next fall                       | 30                |

\*Next fall after cover crop seeding

**908-2.2 INSPECTION.** The DEN Project Manager shall be notified of sources and quantities of mulch materials available and the Contractor shall furnish him with representative samples of the materials to be used 30 days before delivery to the project. These samples may be used as standards with the approval of the DEN Project Manager and any materials brought on the site that do not meet these standards shall be rejected.

**908-2.3 STORAGE.** The Contractor shall store mulch with protection from weather or other conditions that would damage or impact the effectiveness of the product.

### CONSTRUCTION METHODS

**908-3.1 MULCHING.** Before spreading mulch, all large clods, stumps, stones, brush, roots, and other foreign material shall be removed from the area to be mulched. Mulch shall be applied immediately after seeding..

**908-3.2 HYDRAULIC MULCHING.** Wood-fiber mulch and tackifier shall be added to water to form homogeneous slurry. The operator shall apply the slurry mixture uniformly over the designated seeded area via spraying.

Hydraulic mulching shall not be done in the presence of free surface water.

Mixing procedure for the hydraulic mulch and tackifier mixture shall be as follows:

- a. Fill tank with water approximately ¼ full.
- b. Continue filling while agitating with engine at full rpm.
- c. Pour tackifier, at a moderate rate, directly into area of greatest turbulence.
- d. With the recommended amount of tackifier in solution, add wood-fiber mulch.

Do not add fertilizer.

Apply the mulch and tackifier mixture at the following rate:

| <u>Wood-Fiber Mulch</u> | <u>Tackifier</u> | <u>Water</u>   |
|-------------------------|------------------|----------------|
| 2000 lbs./Acre          | 90 lbs./Acre     | 3000 gal./Acre |

After the hydraulic mulch is applied, foot traffic on the mulch surface should be minimized. Mulch once mixed with water and tackifier shall be used within 4 hours. Unused mulch mixture shall be promptly removed from the site.

**908-3.3 MATTING.** All erosion control matting installed will be keyed into the ground surface along all exposed (non-overlapping) edges. Keying will consist placing the edge across a six-inch deep trench and backfilling over the mat to the original ground surface level.

a. **Excelsior.** The area to be covered shall be prepared, fertilized, and seeded, before the blanket is placed. When the blanket is unrolled, the netting shall be on top and the fibers shall be in contact with the soil. In ditches, blankets shall be unrolled in the direction of the flow of water. The end of the upstream blanket shall overlap the buried end of the downstream blanket a maximum of 8 inches and a minimum of 4 inches, forming a junction slot. This junction slot shall be stapled across at 8 inch intervals. Adjoining blankets (side by side) shall be offset 8 inches from center of ditch and overlapped a minimum of 4 inches. Six staples shall be used across the start of each roll, at 4 foot intervals, alternating the center row

so that the staples form an “X” pattern. A common row of staples shall be used on adjoining blankets.

**b. Soil Retention Blanket (Coconut), (Straw), and (Straw and Coconut).** The area to be covered with Soil Retention Blanket (Coconut), (Straw), and (Straw and Coconut) shall be properly prepared, fertilized, and seeded before the blanket is placed. When the blanket is unrolled, the heavyweight polypropylene netting shall be on top and the lightweight polypropylene netting shall be in contact with the soil. In ditches and on slopes, blankets shall be unrolled in the direction of the flow of water. Installation shall be in accordance with manufacturer’s recommendations. A representative of the manufacturer shall be present to give instruction during the installation of the soil retention blanket.

The blanket shall be placed smoothly but loosely on the soil surface without stretching. The upslope end shall be buried in a trench 6 inches wide by 6 inches deep beyond the crest of the slope to avoid undercutting. For slope applications, there shall be a 6 inch overlap wherever one roll of blanket ends and another begins with the uphill blanket placed on top on the blanket on the downhill side. There shall be a 4 inch overlap wherever two widths of blanket are applied side by side. Insert staples in a pattern according to the manufacturer’s recommendation at approximately two staples per square yard.

At terminal ends, and every 35 feet, Soil Retention Blanket (Coconut), (Straw), and (Straw/Coconut) placed in ditches shall be buried in a trench approximately 6 inches deep by 6 inches wide. Before backfilling, staples shall be placed across the width of the trench spaced at 6 inches on center in a zigzag pattern. The trench shall then be backfilled to grade and compacted by foot tamping.

#### **908-3.4 CARE AND REPAIR.**

**a.** The Contractor shall care for the mulched areas until final acceptance of the project. Care shall consist of providing protection against traffic or other use by placing warning signs, as approved by the DEN Project Manager, and erecting any barricades that may be shown on the plans before or immediately after mulching has been completed on the designated areas.

**b.** The Contractor shall be required to repair or replace any mulch that is defective or becomes damaged until the project is finally accepted. When, in the judgment of the DEN Project Manager, such defects or damages are the result of poor workmanship or failure to meet the requirements of the specifications, the cost of the necessary repairs or replacement shall be borne by the Contractor.

### **METHOD OF MEASUREMENT**

**908-4.1** Mulching shall be measured in acres on the basis of the actual surface area acceptably mulched.

### **BASIS OF PAYMENT**



**908-5.1** Payment will be made at the contract unit price per acre for mulching. The price shall be full compensation for furnishing all materials and for placing and anchoring the materials, and for all labor, equipment, tools, and incidentals necessary to complete the item.

Payment will be made under:

Item T-908a Hydraulic Mulching – per acre

**MATERIAL REQUIREMENTS**

ASTM D977 Standard Specification for Emulsified Asphalt

**END OF ITEM T-908**

# DIVISION 26 – ELECTRICAL

Pond 001 Expansion

Construction Contract No.201737313

## Denver International Airport Denver, Colorado

Sponsored By:  
City & County of Denver Department of Aviation

Issued for Construction  
November 21, 2017



## SECTION 26\_05\_00

### COMMON WORK RESULTS FOR ELECTRICAL

#### PART 1 GENERAL

##### 1.01 SUMMARY

- A. Section includes:
  - 1. General requirements applicable to all Electrical Work.
  - 2. General requirements for electrical submittals.
  
- B. Related sections:
  - 1. Section 26\_05\_33 - Conduits.
  - 2. Section 26\_05\_53 - Identification for Electrical Systems.
  - 3. Section 26\_08\_50 - Field Electrical Acceptance Tests.
  - 4. Section 26\_29\_05 - Motor Starters.
  
- C. Interfaces to equipment, instruments, and other components:
  - 1. The Drawings, Specifications, and overall design are based on preliminary information furnished by various equipment manufacturers which identify a minimum scope of supply from the manufacturers. This information pertains to, but is not limited to, instruments, control devices, electrical equipment, packaged mechanical systems, and control equipment provided with mechanical systems.
  - 2. Provide all material and labor needed to install the actual equipment furnished, and include all costs to add any additional conduit, wiring, terminals, or other electrical hardware to the Work, which may be necessary to make a complete, functional installation based on the actual equipment furnished:
    - a. Make all changes necessary to meet the manufacturer's wiring requirements.
  - 3. Submit all such changes and additions to the Engineer for acceptance.
  - 4. Review the complete set of Drawings and Specifications in order to ensure that all items related to the electrical power and control systems are completely accounted for. Include any such items that appear on the Drawings or in the Specifications from another discipline in the scope of Work:
    - a. If a conflict between Drawings and Specifications is discovered, refer conflict to the Engineer as soon as possible for resolution.
  - 5. Loop drawings:
    - a. Provide all electrical information required in the preparation of loop drawings including, but not limited to:
      - 1) Conduit numbers and associated signal(s) contained within each conduit.
      - 2) Wire numbers.
      - 3) Equipment terminal numbers.

- 4) Junction boxes and signal(s) contained within each junction box.
  - 5) Equipment power sources, and associated circuit numbers.
  - 6) As-built drawings detailing wiring.
- D. All electrical equipment and systems for the entire Project must comply with the requirements of the Electrical Specifications, whether referenced in the individual Equipment Specifications or not:
1. The requirements of the Electrical Specifications apply to all Electrical Work specified in other sections.
  2. Inform all vendors supplying electrical equipment or systems of the requirements of the Electrical Specifications.
  3. Owner is not responsible for any additional costs due to the failure of Contractor to notify all subcontractors and suppliers of the Electrical Specifications requirements.
- E. Contract Documents:
1. General:
    - a. The Drawings and Specifications are complementary and are to be used together in order to fully describe the Work.
  2. Specifications:
    - a. The General and Supplementary Conditions of the Contract Documents govern the Work.
    - b. These requirements are in addition to all General Requirements.
  3. Contract Drawings:
    - a. The Electrical Drawings show desired locations, arrangements, and components of the Electrical Work in a diagrammatic manner.
    - b. Locations of equipment, control devices, instruments, boxes, panels, etc. are approximate only; exercise professional judgment in executing the Work to ensure the best possible installation:
      - 1) The equipment locations and dimensions indicated on the Drawings are approximate. Use the shop drawings to determine the proper layout, foundation, and pad requirements, etc. for final installation. Coordinate with all subcontractors to ensure that all electrical equipment is compatible with other equipment and space requirements. Make changes required to accommodate differences in equipment dimensions.
      - 2) The Contractor has the freedom to select any of the named manufacturers identified in the individual specification sections; however, the Engineer has designed the spatial equipment layout based upon a single manufacturer and has not confirmed that every named manufacturer's equipment fits in the allotted space. It is the Contractor's responsibility to ensure that the equipment being furnished fits within the defined space.

- c. Installation details:
  - 1) The Contract Drawings include typical installation details the Contractor is to use to complete the Electrical Work. For cases where a typical detail does not apply, develop installation details that may be necessary for completing the Work, and submit these details for review by the Engineer.
  - 2) Not all typical installation details are referenced within the Drawing set. Apply and use typical details where appropriate.
- d. Schematic diagrams:
  - 1) All controls are shown de-energized.
  - 2) Schematic diagrams show control function only. Incorporate other necessary functions for proper operation and protection of the system.
  - 3) Add slave relays, where required, to provide all necessary contacts for the control system or where needed to function as interposing relays for control voltage coordination, equipment coordination, or control system voltage drop considerations.
  - 4) Mount all devices shown on motor controller schematic diagrams in the controller compartment enclosure, unless otherwise noted or indicated.
  - 5) Schematic diagrams are to be used in conjunction with the descriptive operating sequences in the Contract Documents. Combine all information and furnish a coordinated and fully functional control system.

## 1.02 REFERENCES

- A. Code compliance:
  - 1. The publications are referred to in the text by the basic designation only. The latest edition accepted by the Authority Having Jurisdiction of referenced publications in effect at the time of the bid governs.
  - 2. The standards listed are hereby incorporated into this Section.
    - a. American National Standards Institute (ANSI).
    - b. American Society of Civil Engineers (ASCE):
      - 1) ASCE 7 - Minimum Design Loads for Buildings and Other Structures.
    - c. ASTM International (ASTM).
    - d. Illuminating Engineering Society (IES).
    - e. Institute of Electrical and Electronics Engineers (IEEE).
    - f. Insulated Cable Engineers Association (ICEA).
    - g. International Code Council (ICC).
      - 1) International Code Council Evaluation Service (ICC-ES).
        - a) AC 156 – Acceptance Criteria for Seismic Certification by Shake Table Testing of Non-Structural Components (ICC-ES AC 156).
    - h. International Society of Automation (ISA).
    - i. National Electrical Manufacturers Association (NEMA):
      - 1) 250 - Enclosures for Electrical Equipment (1000 V Maximum).

- j. National Fire Protection Association (NFPA):
  - 1) 70 - National Electrical Code (NEC).
- k. National Institute of Standards and Technology (NIST).
- l. Underwriters' Laboratories, Inc. (UL).

### 1.03 DEFINITIONS

- A. Definitions of terms and other electrical and instrumentation considerations as set forth by:
  - 1. IEEE.
  - 2. NETA.
  - 3. IES.
  - 4. ISA.
  - 5. NEC.
  - 6. NEMA.
  - 7. NFPA.
  - 8. NIST.
- B. Specific definitions:
  - 1. FAT: Factory acceptance test.
  - 2. ICSC: Instrumentation and controls subcontractor.
  - 3. LCP: Local control panel: Operator interface panel that may contain an HMI, pilot type control devices, operator interface devices, control relays, etc. and does not contain a PLC or RIO.
  - 4. PCM: Process control module: An enclosure containing any of the following devices: PLC, RTU, or RIO.
  - 5. PCIS: Process control and instrumentation system.
  - 6. RTU: Remote telemetry unit: A controller typically consisting of a PLC, and a means for remote communications. The remote communications devices typically are radios, modems, etc.
  - 7. Space: That portion of the switchgear, motor control center, panelboard, switchboard or control panel that does not physically contain a device but is capable of accepting a device with no modifications to the equipment, i.e., provide all standoffs, bus, and hardware, as part of the space.
  - 8. Spare: That portion of the switchgear, motor control center, panelboard, switchboard or control panel that physically contains a device with no load connections to be made.
  - 9. VCP: Vendor control panel: Control panels that are furnished with particular equipment by a vendor other than the ICSC. These panels may contain PLCs, RIO, OIT, HMI, etc.
  - 10. Unequipped space: That portion of the switchgear, motor control center, panelboard, switchboard or control panel that does not physically contain a device, standoff, bus, hardware, or other equipment.

## 1.04 SYSTEM DESCRIPTION

### A. General requirements:

1. The Work includes everything necessary for and incidental to executing and completing the Electrical Work indicated on the Drawings and specified in the Specifications and reasonably inferable there from:
  - a. The Electrical Drawings are schematic in nature; use the Structural, Architectural, Mechanical, and Civil Drawings for all dimensions and scaling purposes.
2. It is the intent of these Specifications that the entire electrical power, instrumentation, and control system be complete and operable. Provide all necessary material and labor for the complete system from source of power to final utilization equipment, including all connections, testing, calibration of equipment furnished by others as well as equipment furnished by the Contractor, whether or not specifically mentioned but which are necessary for successful operation.
3. Provide all Electrical Work, including conduit, field wiring, and connections by the electrical subcontractor under the provisions of the Electrical Specifications for all aspects of the Work.
4. Coordinate all aspects of the Work with the electrical subcontractor and other subcontractors before bidding in order to ensure that all costs associated with a complete installation are included. The Owner is not responsible for any change orders due to lack of coordination of the Work between the Contractor, the electrical subcontractor, the other subcontractors or suppliers.
5. Portions of this Project involve installation in existing facilities and interfaces to existing circuits, power systems, controls, and equipment:
  - a. Perform and document comprehensive and detailed field investigations of existing conditions (circuits, power systems, controls, equipment, etc.) before starting any Work. Determine all information necessary to document, interface with, modify, upgrade, or replace existing circuits, power systems, controls, and equipment.
  - b. Provide and document interface with, modifications to, upgrades, or replacement of existing circuits, power systems, controls, and equipment.
6. Provide all trenching, forming, rebar, concrete, back filling, hard surface removal and replacement, for all items associated with the Electrical Work and installation:
  - a. As specified in the Contract Documents.

### B. Existing system:

1. Pond 001 with cell (1) and cell (2). Ahead of the pond cells is a gate splitter structure. An existing vendor control panel controls the hydraulic gates that are selectable to control captured facility run off to designated pond cell.
2. Gate NO. (1) and NO. (2) Controlled by Rodney Hunt control panel communicates to facility SCADA via a (6) strand mutli-mode fiber optic line to the pump house PLC.



3. Each of Pond 001 cells have an existing bubbler system that measures level. This measurement is sent back to the pump house PLC that is also displayed on facility SCADA that calculates the volume.
  4. Electrical and communications line are installed in an existing duct bank system. Future and spare conduits are available to route from existing pump house to existing manholes.
- C. New system:
1. A new gate NO. (3) Will be added to the north end of the existing splitter structure.
  2. A new Rodney Hunt hydraulic control panel will need to be installed for the new Gate NO. (3).
  3. Duct bank and above ground conduit will need to be routed from the existing electrical manholes to the new equipment. New cable from the existing pump house to the new equipment will need to be pulled, terminated and tested.
  4. A new power feed for the new equipment will be fed from the existing MCC that will require a new MCC feeder breaker.
  5. To establish communication from the new equipment a new patch cable will be installed between the two Rodney Hunt hydraulic actuator control panels.
  6. A new level transmitter will be installed on the third new cell in a new valve vault that transmits level back to the PLC.
  7. Modifications to the existing SCADA programming and HMI will need to be performed to make operational control and monitoring of Gate NO. (3) and Cell NO. (3) function.
  8. The total connected load exceeds the capacity of the MCC main breaker. A new 200Amp main breaker will need to be installed to increase capacity.
  9. The feeder conductors from the existing utility transformer will need to be upsized to accommodate the load for the new MCC main breaker.
  10. Coordinate with XCEL energy and upsize the existing transformer if XCEL determine the new loading will be unacceptable. Only one pump is used at a time and only on hydraulic gate system should be used at a time.
- D. Operating facility:
1. The DIA is an operating facility. Portions of this facility must remain fully functional throughout the entire construction period. In consideration of this requirement, comply with the following guidelines:
    - a. All outages must be of minimal duration and fully coordinated and agreed to by the Owner. Adjust the construction schedule to meet the requirements of the Owner. All changes in schedule and any needs to reschedule are included in the Work.
    - b. As weather and water demand conditions dictate, re-adjust the construction schedule to meet the demands placed upon Owner by its users.
    - c. Coordinate the construction and power renovation, bear all costs, so that all existing facilities can continue operation throughout construction.
  2. According to individual circumstances and in compliance with the Drawings, extend or replace conduit and cable connections from existing locations.

3. The standards of documentation, instrument tagging, cable and conductor ferruling, terminal identification and labeling that apply to the new installation apply equally to the existing installation which forms part of the modified system.

## 1.05 SUBMITTALS

- A. Furnish submittals as specified in this Section.
- B. General:
  1. Instruct all equipment suppliers of submittals and operation and maintenance manuals of the requirements in this Section.
  2. Furnish the submittals required by each section in the Electrical Specifications.
  3. Adhere to the wiring numbering scheme specified in Section 26\_05\_53 throughout the Project:
    - a. Uniquely number each wire.
    - b. Wire numbers must appear on all Equipment Drawings.
  4. Use equipment and instrument tags, as indicated on the Drawings, for all submittals.
- C. Seismic requirements:
  1. Provide electrical equipment with construction and anchorage to supporting structures designed to resist site seismic loads based on the seismic design criteria.
  2. For equipment installed in structures designated as seismic design category C, D, E or F, prepare and submit the following:
    - a. Statement of seismic qualification, and special seismic certification:
      - 1) "Statement of seismic qualification:" Provide manufacturer's statement that the equipment satisfies the seismic design requirements of the building code, including the requirements of ASCE 7, Chapter 13.
      - 2) "Special seismic certification:" Provide manufacturer's certification that the equipment, when subjected to shake table testing in accordance with ICC-ES AC 156, meets the "Post-Test Functional Compliance Verification" requirements of ICC-ES AC 156 for "Components with  $I_p = 1.5$ ." Compliance shall include both operability and containment of hazardous materials as appropriate to the unit being tested.
    - b. Substantiating test data: With seismic qualification and special seismic certification statements, submit results of testing in accordance with ICC-ES AC 156.

- c. Anchoring design calculations and details:
  - 1) Submit project-specific drawings and supporting calculations, prepared and sealed by a professional engineer licensed in the state where the Project is being constructed, and showing details for anchoring electrical equipment to its supports and for anchoring supports provided with the equipment to the structure. Prepare calculations in accordance with the requirements.
- 3. Exemptions: A “statement of seismic qualification” and a “special seismic certification” are not required for the following equipment:
  - a. Temporary or moveable equipment.
  - b. Equipment anchored to the structure and having a total weight of 20 pounds or less.
  - c. Distribution equipment anchored to the structure and having a total unit weight of 3 pounds per linear foot, or less.
- D. Submittal organization:
  - 1. First page:
    - a. Specification section reference.
    - b. Name and telephone number of individual who reviewed submittal before delivery to Engineer.
    - c. Name and telephone number of individual who is primarily responsible for the development of the submittal.
    - d. Place for Contractor’s review stamp and comments.
  - 2. Next pages:
    - a. Provide confirmation of specification compliance:
      - 1) Specification section: Include with each submittal a copy of the relevant specification section.
        - a) Indicate in the left margin, next to each pertinent paragraph, either compliance with a check (√) or deviation with a consecutive number (1, 2, 3).
        - b) Provide a list of all numbered deviations with a clear explanation and reason for the deviation.
    - b. Include a response in writing to each of the Engineer’s comments or questions for submittal packages which are re-submitted:
      - 1) In the order that the comments or questions were presented throughout the submittal.
      - 2) Referenced by index section and page number on which the comment appeared.
      - 3) Acceptable responses to Engineer’s comments are either:
        - a) Engineer’s comment or change is accepted and appropriate changes are made.
        - b) Explain why comment is not accepted or requested change is not made.
        - c) Explain how requirement will be satisfied in lieu of comment or change requested by Engineer.
      - 4) Any re-submittal, which does not contain responses to the Engineer’s previous comments shall be returned for Revision and Re-submittal.

- 5) No further review by the Engineer will be performed until a response for previous comments has been received.
3. Remaining pages:
  - a. Actual submittal data:
    - 1) Organize submittals in exactly the same order as the items are referenced, listed, and/or organized in the specification section.
    - 2) For submittals that cover multiple devices used in different areas under the same specification section, the submittal for the individual devices must list the area where the device is intended to be used.
- E. Submittal requirements:
  1. Furnish submittals that are fully indexed with a tabbed divider for every component.
  2. Sequentially number pages within the tabbed sections. Submittals and operation and maintenance manuals that are not fully indexed and tabbed with sequentially numbered pages, or are otherwise unacceptable, will be returned without review.
  3. Edit all submittals and operation and maintenance manuals so that the submittal specifically applies to only the equipment furnished.
    - a. Neatly cross out all extraneous text, options, models, etc. that do not apply to the equipment being furnished, so that the information remaining is only applicable to the equipment being furnished.
  4. Submit copies of shop drawings, and product data:
    - a. Show dimensions, construction details, wiring diagrams, controls, manufacturers, catalog numbers, and all other pertinent details.
  5. Where submittals are required, provide a separate submittal for each specification section. In order to expedite construction, the Contractor may make more than 1 submittal per specification section, but a single submittal may not cover more than 1 specification section:
    - a. The only exception to this requirement is when 1 specification section covers the requirements for a component of equipment specified in another section. (For example, circuit breakers are a component of switchgear. The switchgear submittal must also contain data for the associated circuit breakers, even though they are covered in a different specification section.)
  6. Exceptions to Specifications and Drawings:
    - a. Include a list of proposed exceptions to the Specifications and Drawings along with a detailed explanation of each.
    - b. If there is insufficient explanation for the exception or deviation, the submittal will be returned requiring revision and re-submittal.
    - c. Acceptance of any exception is at the sole discretion of the Engineer.
      - 1) Provide all items (materials, features, functions, performance, etc.) required by the Contract Documents that are not accepted as exceptions.
    - d. Replace all items that do not meet the requirements of the Contract Documents, which were not previously accepted as exceptions, even if the submittals contained information indicating the failure to meet the requirements.

7. Specific submittal requirements:
  - a. Shop drawings:
    - 1) Required for materials and equipment listed in this and other sections.
    - 2) Furnish sufficient information to evaluate the suitability of the proposed material or equipment for the intended use, and for compliance with these Specifications.
    - 3) Shop drawings requirements:
      - a) Front, side, and, rear elevations, and top and bottom views, showing all dimensions.
      - b) Locations of conduit entrances and access plates.
      - c) Component layout and identification.
      - d) Schematic and wiring diagrams with wire numbers and terminal identification.
      - e) Connection diagrams, terminal diagrams, internal wiring diagrams, conductor size, etc.
      - f) Anchoring method and leveling criteria, including manufacturer's recommendations for the Project site seismic criteria.
      - g) Weight.
      - h) Finish.
      - i) Nameplates:
        - (1) As specified in Section 26\_05\_53.
      - j) Temperature limitations, as applicable.
  - b. Product data:
    - 1) Submitted for non-custom manufactured material listed in this and other sections and shown on shop drawings.
    - 2) Include:
      - a) Catalog cuts.
      - b) Bulletins.
      - c) Brochures.
      - d) Quality photocopies of applicable pages from these documents.
      - e) Identify on the data sheets the Project name, applicable specification section, and paragraph.
      - f) Identify model number and options for the actual equipment being furnished.
      - g) Neatly cross out options that do not apply or equipment not intended to be supplied.
  - c. Detailed sequence of operation for all equipment or systems.
- F. Operation and maintenance manuals:
  1. Furnish the Engineer with a complete set of written operation and maintenance manuals 8 weeks before Functional Acceptance Testing.
  2. Additional operation and maintenance manual requirements:
    - a. Completely index manuals with a tab for each section:
      - 1) Each section containing applicable data for each piece of equipment, system, or topic covered.

- 2) Assemble manuals using the approved shop drawings, and include, the following types of data:
  - a) Complete set of 11-inch by 17-inch drawings of all equipment.
  - b) Complete set of control schematics.
  - c) Complete parts list for all equipment being provided.
  - d) Catalog data for all products or equipment furnished.
  
- G. Material and equipment schedules:
  1. Furnish a complete schedule and/or matrix of all materials, equipment, apparatus, and luminaries that are proposed for use:
    - a. Include sizes, names of manufacturers, catalog numbers, and such other information required to identify the items.
  
- H. Schedule of values:
  1. In addition to completing all items referred to in the schedule of values, submit per unit material and labor costs used in developing the final bid for the electrical system, for the express purpose of pricing and cost justification for any proposed change orders. In addition to the items shown on the schedule of values, provide per unit material and labor costs for conduit and wire installation for specific types, sizes, and locations as indicated on the Drawings and Conduit Schedule. It is the responsibility of the electrical subcontractor to prove to the Engineer's satisfaction that said per unit costs were used in the development of the final Bid amount.
  
- I. Roof penetrations:
  1. Submit details of all portions of the electrical installation that penetrate the roof. Include details showing support of the penetrating component, and the sealing means to be utilized.
  
- J. Record Documents:
  1. Provide Record Documents of all Electrical Drawings.
  2. Record Drawing requirements:
    - a. Update Record Drawings weekly.
    - b. Record Drawings must be fully updated as a condition of the monthly progress payments.
    - c. Submit Record Drawings upon completion of the Work for final review.
    - d. Clearly and neatly show all changes including the following:
      - 1) All existing pipe, conduit, wire, instruments or other structures encountered or uncovered during construction.
  3. Shop drawings:
    - a. Upon completion of the Work, update all shop drawings to indicate the final as-built configuration of the systems:
      - 1) Provide as-built shop drawings for all electrical equipment on 11-inch by 17-inch paper.
        - a) Size all drawings to be readable and legible on 11-17 inch media.
      - 2) Provide electronic copies of these documents on CD-ROM or DVD disks in PDF format.

4. Review and corrections:
  - a. Correct any record documents or other documents found to be incomplete, not accurate, of poor quality, or containing errors.
  - b. Promptly correct and re-submit record documents returned for correction.
  
- K. Test reports:
  1. Include the following:
    - a. A description of the test.
    - b. List of equipment used.
    - c. Name of the person conducting the test.
    - d. Date and time the test was conducted.
    - e. All raw data collected.
    - f. Calculated results.
    - g. Each report signed by the person responsible for the test.
  2. Additional requirements for field acceptance test reports are specified in Sections 26\_08\_50.
  
- L. Calculations:
  1. Where required by specific Electrical Specifications:
    - a. Because these calculations are being provided by a registered professional engineer, they will be reviewed for form, format, and content but will not be reviewed for accuracy and calculation means.

## 1.06 QUALITY ASSURANCE

- A. Furnish all equipment listed by and bearing the label of UL or of an independent testing laboratory acceptable to the Engineer and the Authority Having Jurisdiction.
  
- B. System supplier responsibilities:
  1. Requirements as specified in the Instrumentation and Control Specifications.
  2. System supplier:
    - a. Due to the critical and complex technical requirements of this Project, all Work (materials, equipment, products, submittals, labor, services, etc.) specified in the Electrical, and Instrumentation and Control Specifications, and shown on the Electrical and Instrumentation Drawings is to be furnished by a single system supplier who has single source responsibility for both the process control and instrumentation systems and the electrical power system.
  3. Contractual relationship:
    - a. Form a contractual relationship between the electrical subcontractor and the ICSC.
    - b. Requirements for the first tier subcontractor:
      - 1) Contract directly with the Contractor.
      - 2) Be either the electrical subcontractor or the ICSC.
    - c. Requirements for the second tier subcontractor:
      - 1) A division of the first tier subcontractor, or
      - 2) A joint venture with the first tier subcontractor, or

- 3) A subcontractor to the first tier subcontractor.
- d. The system supplier manages, directs, and supervises all of the Work of its second tier subcontractor. The system supplier is solely responsible for the entire electrical and instrumentation system, including, but not limited to, all Electrical, Instrumentation, and Process Contract Drawings, Electrical Specifications, and Instrumentation and Control Specifications:
  - 1) Provide any additional conduit, wire, etc.
  - 2) Any additional I/O, programming, screens, interface devices needed by the system supplier are to be provided by the electrical subcontractor or the ICSC, under the above outlined working agreement.
  - 3) Ensure compatibility between the PCIS system and the electrical system being installed.

## 1.07 DELIVERY, STORAGE, AND HANDLING

- A. Shipping precautions:
  1. After completion of shop assembly and successful factory testing, pack all equipment in protective crates, and enclose in heavy duty polyethylene envelopes or secured sheeting to provide complete protection from damage, dust, and moisture.
  2. Place dehumidifiers, when required, inside the polyethylene coverings.
  3. Skid-mount the equipment for final transport.
  4. Provide lifting rings for moving without removing protective covering.
  5. Display boxed weight on shipping tags together with instructions for unloading, transporting, storing, and handling at the job site.
- B. Delivery and inspection:
  1. Deliver products in undamaged condition, in manufacturer's original container or packaging with identifying labels intact and legible. Include date of manufacture on label.
- C. Special instructions:
  1. Securely attach special instructions for proper field handling, storage, and installation to each piece of equipment before packaging and shipment.

## 1.08 PROJECT OR SITE CONDITIONS

- A. Site conditions:
  1. Provide an electrical, instrumentation and control system, including all equipment, raceways, and any other components required for a complete installation that meets the environmental conditions for the Site as specified in the General Requirements and below.
  2. Seismic load resistance:
    - a. Provide electrical equipment with construction and anchorage to supporting structures designed to resist site seismic loads.



3. Wind load resistance:
    - a. Provide electrical equipment with construction and anchorage to supporting structures designed to resist site wind loads.
  4. Altitude, temperature and humidity:
    - a. Provide all electrical components and equipment fully rated for continuous operation at this altitude, with no additional derating factors applied.
    - b. Provide additional temperature conditioning equipment to maintain all equipment in non-conditioned spaces subject to these ambient temperatures, with a band of 10 degrees Fahrenheit above the minimum operating temperature and 10 degrees Fahrenheit below maximum operating temperature, as determined by the equipment manufacturer's guidelines:
      - 1) Provide all power conduits wiring for these devices (e.g. heaters, fans, etc.) whether indicated on the Drawings or not.
  5. Site security:
    - a. Abide by all security and safety rules concerning the Work on the Site.
  6. Outdoor installations:
    - a. Provide electrical, instrumentation and control equipment suitable for operation in the ambient conditions where the equipment is located.
    - b. Provide heating, cooling, and dehumidifying devices incorporated into and included with electrical equipment, instrumentation and control panels to maintain the enclosures within the rated environmental operating ranges as specified in this Section for the equipment:
      - 1) Provide all wiring necessary to power these devices.
- B. Provide enclosures for electrical, instrumentation and control equipment, regardless of supplier or subcontractor furnishing the equipment, that meet the requirements outlined in NEMA Standard 250 for the following types of enclosures:
1. NEMA Type 1: Intended for indoor use, primarily to provide a degree of protection from accidental contact with energized parts or equipment.
  2. NEMA Type 4: Intended for indoor or outdoor use, primarily to protect equipment from exposure to windblown dust and rain, splashing or hose directed water, ice formation and freezing.
  3. NEMA Type 4X: Made from corrosion resistant materials (fiberglass reinforced plastic, 316 stainless steel or equal) and are intended for indoor or outdoor use, primarily to protect equipment from exposure to windblown dust and rain, splashing or hose directed water, ice formation and freezing, and corrosion.
  4. NEMA Type 12: Intended for indoor use, primarily to provide a degree of protection from dust, falling dirt and dripping non-corrosive liquids.
  5. NEMA Type 6: Rated for submergence.
  6. NEMA Type 6P: Rated for prolonged submergence.

- C. Plant area Electrical Work requirements:
1. Provide all Electrical Work in accordance with the following table, unless otherwise specifically indicated on the Drawings:

| PLANT AREA  | NEMA ENCLOSURE TYPE | EXPOSED CONDUIT TYPE | ENVIRONMENT<br>W = WET<br>D = DAMP<br>C = CLEAN/DRY<br>X = CORROSIVE<br>H = HAZARDOUS | SUPPORT MATERIALS |
|-------------|---------------------|----------------------|---|-------------------|
| Pump House  | 4                   | GRC                  | D   | GALV              |
| Outside     | 4X                  | GRC                  | W   | GALV              |
| Underground | Manhole             | PVC/PCS              | W   | PVC               |

2. Modify exposed conduit runs as specified in Section 26\_05\_33.

### 1.09 WARRANTY

- A. Warrant the Electrical Work as specified:
1. Provide additional warranty as specified in the individual Electrical Specifications.

### 1.10 SYSTEM START-UP

- A. Replace or modify equipment, software, and materials that do not achieve design requirements after installation in order to attain compliance with the design requirements:
1. Following replacement or modification, retest the system and perform additional testing to place the complete system in satisfactory operation and obtain compliance acceptance from the Engineer.

### 1.11 MAINTENANCE

- A. Before Substantial Completion, perform all maintenance activities required by any sections of the Specifications including any calibrations, final adjustments, component replacements or other routine service required before placing equipment or systems in service.
- B. Furnish all spare parts as required by other sections of the Specifications.

## **PART 2 PRODUCTS**

### **2.01 MANUFACTURERS**

- A. Provide similar items of same manufacturer throughout the electrical and instrumentation portion of the Project.
- B. Allowable manufacturers are specified in individual Electrical Specifications.

### **2.02 MATERIALS**

- A. Furnish all materials under this Contract that are new, free from defects, and standard products produced by manufacturers regularly engaged in the production of these products and that bear all approvals and labels as required by the Specifications.
- B. Provide materials complying with the applicable industrial standard.
- C. Stainless steel:
  - 1. Where stainless steel is indicated or used for any portion of the Electrical Work, provide a non-magnetic, corrosion-resistant alloy, ANSI Type 316, satin finish.
  - 2. Provide exposed screws of the same alloys.
  - 3. Provide finished material free of any burrs or sharp edges.
  - 4. Use only stainless steel hardware, when chemically compatible, in all areas that are or could be in contact with corrosive chemicals.
  - 5. Use stainless steel hardware, when chemically compatible, in all chemical areas or areas requiring NEMA Type 4X construction.
  - 6. Do not use stainless steel in any area containing chlorine, gas or solution, chlorine products or ferric chloride.

### **2.03 SOURCE QUALITY CONTROL**

- A. Provide all equipment that is new, free from defects, and standard products produced by manufacturers regularly engaged in the production of these products.

## **PART 3 EXECUTION**

### **3.01 EXAMINATION**

- A. The electrical subcontractor is encouraged to visit the site to examine the premises completely before bidding.
- B. It is the electrical subcontractor's responsibility to be fully familiar with the existing conditions and local requirements and regulations.
- C. Comply with pre-bid conference requirements.

- D. Review the site conditions and examine all shop drawings for the various items of equipment in order to determine exact routing and final terminations for all wiring and cables.

### 3.02 INSTALLATION

- A. Equipment locations shown on Electrical Drawings may change due to variations in equipment size or minor changes made by others during construction:
  - 1. Verify all dimensions indicated on the Drawings:
    - a. Actual field conditions govern all final installed locations, distances, and levels.
  - 2. Review all Contract Documents and approved equipment shop drawings and coordinate Work as necessary to adjust to all conditions that arise due to such changes.
  - 3. Make minor changes in location of equipment before rough in, as directed by the Owner or Engineer.
  - 4. Provide a complete electrical system:
    - a. Install all extra conduits, cables, and interfaces as may be necessary to provide a complete and operating electrical system.
- B. Install the equipment in accordance with the accepted installation instructions and anchorage details to meet the seismic and wind load requirements at the Project site.
- C. Cutting and patching:
  - 1. Perform all cutting, patching, channeling, core drilling, and fitting required for the Electrical Work, except as otherwise directed:
    - a. Secure the permission of the Engineer before performing any operation likely to affect the strength of a structural member such as drilling, cutting or piercing:
      - 1) Before cutting, channeling, or core drilling any surface, ensure that no penetration of any other systems will be made:
        - a) Verify that area is clear and free of conduits, cables, piping, ductwork, post-tensioning cables, etc.
        - b) Use tone-locate system or X-ray to ensure that area is clear of obstructions.
    - b. Review the complete Drawing set to ensure that there are no conflicts or coordination problems before cutting, channeling, or core drilling any surface.
  - 2. Perform all patching to the same quality and appearance as the original work. Employ the proper tradesmen to secure the desired results. Seal around all conduits, wires, and cables penetrating walls, ceilings, and floors in all locations with a fire stop material, typically:
    - a. 3M: CP 25WB+: Caulk.
    - b. 3M: Fire Barrier: Putty.
  - 3. Use the installation details indicated on the Drawings as a guide for acceptable sealing methods.

- D. Install all conduits and equipment in such a manner as to avoid all obstructions and to preserve headroom and keep openings and passageways clear:
1. Install all conduits and equipment in accordance with working space requirements in accordance with the NEC.
    - a. This includes any panel, disconnect switch or other equipment that can be energized while open exposing live parts regardless of whether it is likely to require examination or has serviceable parts.
  2. Where the Drawings do not show dimensions for locating equipment, install equipment in the approximate locations indicated on the Drawings.
    - a. Adjust equipment locations as necessary to avoid any obstruction or interferences.
  3. Where an obstruction interferes with equipment operation or safe access, relocate the equipment.
  4. Where the Drawings do not indicate the exact mounting and/or supporting method to be used, use materials and methods similar to the mounting details indicated on the Drawings.
- E. Earthwork and concrete:
1. Install all trenching, shoring, concrete, backfilling, grading and resurfacing associated with the Electrical Work:
    - a. Requirements as specified in the Contract Documents.
- F. Terminations:
1. Provide and terminate all conductors required to interconnect power, controls, instruments, panels, and all other equipment.
- G. Miscellaneous installation requirements:
1. In case of interference between electrical equipment indicated on the Drawings and the other equipment, notify the Engineer.
  2. Location of manholes and pullboxes indicated on the Drawings are approximate. Coordinate exact location of manholes and pullboxes with Mechanical and Civil Work.
  3. Provide additional manholes or pullboxes to those shown where they are required to make a workable installation.
  4. Circuits of different service voltage:
    - a. Voltage and service levels:
      - 1) Medium voltage: greater than 1.0 kV.
      - 2) Low voltage: 120 V to 480 V.
      - 3) Instrumentation: Less than 50 VDC.
    - b. Install different service voltage circuits in separate raceways and junction boxes.
    - c. In manholes, install all cables operating at less than 50 VDC in PVC coated flexible metallic conduit, with corrosion resistant fittings.
- H. Labeling:
1. Provide all nameplates and labels as specified in Sections 26\_05\_53 and 26\_05\_74.

- I. Equipment tie-downs:
  - 1. Anchor all instruments, control panels, and equipment by methods that comply with seismic and wind bracing criteria, which apply to the Site.
  - 2. All control panels, VCPs, LCPs, RTUs, PCMs, etc., must be permanently mounted and tied down to structures in accordance with the Project seismic criteria.

### 3.03 COMMISSIONING

- A. For Owner and Engineer witnessed FAT:
  - 1. Contractor is responsible for the Owner's and Engineer's costs associated with FAT.
- B. Owner training:
  - 1. As specified in this Section.

### 3.04 FIELD QUALITY CONTROL

- A. Inspection:
  - 1. Allow for inspection of electrical system installation as specified.
  - 2. Provide any assistance necessary to support inspection activities.
  - 3. Engineer inspections may include, but are not limited to, the following:
    - a. Inspect equipment and materials for physical damage.
    - b. Inspect installation for compliance with the Drawings and Specifications.
    - c. Inspect installation for obstructions and adequate clearances around equipment.
    - d. Inspect equipment installation for proper leveling, alignment, anchorage, and assembly.
    - e. Inspect equipment nameplate data to verify compliance with design requirements.
    - f. Inspect raceway installation for quality workmanship and adequate support.
    - g. Inspect cable terminations.
  - 4. Inspection activities conducted during construction do not satisfy inspection or testing requirements specified in Section 26\_08\_50.
- B. Field acceptance testing (Functional Testing):
  - 1. Notify the Engineer when the Electrical Work is ready for field acceptance testing.
  - 2. Perform the field acceptance tests as specified in Section 26\_08\_50.
  - 3. Record results of the required tests along with the date of test:
    - a. Use conduit identification numbers to indicate portion of circuit tested.
- C. Workmanship:
  - 1. Leave wiring in panels, manholes, boxes, and other locations neat, clean, and organized:
    - a. Neatly coil and label spare wiring lengths.

- b. Shorten, re-terminate, and re-label excessive used as well as spare wire and cable lengths, as determined by the Engineer.

### **3.05 CLEANING**

- A. Remove all foreign material and restore all damaged finishes to the satisfaction of the Engineer and Owner.
- B. Clean and vacuum all enclosures to remove all metal filings, surplus insulation and any visible dirt, dust or other matter before energization of the equipment or system start-up:
  - 1. Use of compressors or air blowers for cleaning is not acceptable.
- C. Clean and re-lamp all new and existing luminaries that were used in the areas affected by the construction, and return all used lamps to the Owner.
- D. As specified in other sections of the Contract Documents.

### **3.06 PROTECTION**

- A. Protect all Work from damage or degradation until Substantial Completion.
- B. Maintain all surfaces to be painted in a clean and smooth condition.

## **PART 4 MEASUREMENT**

### **4.01 METHOD OF MEASUREMENT**

- A. No separate measurement shall be made for work under this Section.

## **PART 5 PAYMENT**

### **5.01 METHOD OF PAYMENT**

- A. No separate payment will be made for work under this Section. The cost of the work described in this Section shall be included in the applicable lump sum bid item.

END OF SECTION

## SECTION 26\_05\_18

### 600-VOLT OR LESS WIRES AND CABLES

#### PART 1 GENERAL

##### 1.01 SUMMARY

- A. Section includes:
  - 1. 600 volt class or less wire and cable.
- B. Related sections:
  - 1. Section 26\_05\_00 - Common Work Results for Electrical.
  - 2. Section 26\_05\_26 - Grounding and Bonding.
  - 3. Section 26\_05\_53 - Identification for Electrical Systems.

##### 1.02 REFERENCES

- A. As specified in Section 26\_05\_00.
- B. ASTM International (ASTM):
  - 1. B3 - Standard Specification for Soft or Annealed Copper Wire.
  - 2. B8 - Standard Specification for Concentric-Lay-Stranded Copper Conductors, Hard, Medium-Hard, or Soft.
- C. CSA International (CSA).
- D. Insulated Cable Engineers Association (ICEA):
  - 1. NEMA WC 70/ICEA S-95-658-1999 - Standard for Nonshielded Power Cables Rated 2000 Volts or Less for the Distribution of Electrical Energy.
  - 2. NEMA WC 57/ICEA S-73-532 - Standard for Control, Thermocouple Extension, and Instrumentation Cables.
- E. National Fire Protection Association (NFPA):
  - 1. 70 - National Electrical Code (NEC).
  - 2. 72 - National Fire Alarm and Signaling Code.
  - 3. 101 - Life Safety Code.
- F. Telecommunications Industry Association/Electronics Industry Association (TIA/EIA):
  - 1. 568-C.2 - Balanced Twisted-Pair Telecommunication Cabling and Components Standard.
- G. Underwriter's Laboratories Inc., (UL):
  - 1. 44 - Thermoset-Insulated Wires and Cables.



2. 1277 - Standard for Electrical Power and Control Tray Cables with Optional Optical-Fiber Members.
3. 1424 - Standard for Cables for Power-Limited Fire-Alarm Circuits.
4. 1569 - Standard for Metal-Clad Cables.
5. 2196 - Standard for Tests for Fire Resistive Cables.
6. 2225 - Standard for Cables and Cable-Fittings for Use in Hazardous (Classified) Locations.

### 1.03 DEFINITIONS

- A. As specified in Section 26\_05\_00.
- B. Specific definitions and abbreviations:
  1. AWG: American wire gauge.
  2. BCCS: Bare copper-covered steel.
  3. CPE: Chlorinated polyethylene.
  4. FEP: Fluorinated ethylene propylene.
  5. FHDPE: Foam high-density polyethylene.
  6. FPE: Foam polyethylene.
  7. OD: Outside diameter.
  8. PVC: Polyvinyl chloride.
  9. XHHW: Cross-linked high heat water resistant insulated wire.
  10. 2CS: Two Conductor signal wire with shield.
- C. Definitions of terms and other electrical considerations as set forth in the:
  1. ASTM.
  2. ICEA.

### 1.04 SYSTEM DESCRIPTION

- A. Furnish and install the complete wire and cable system.

### 1.05 SUBMITTALS

- A. Furnish submittals as specified in Section 26\_05\_00.
- B. Product data:
  1. Manufacturer of wire and cable.
  2. Insulation:
    - a. Type.
    - b. Voltage class.
  3. AWG size.
  4. Conductor material.
  5. Pulling compounds.

- C. Shop drawings:
  - 1. Show splice locations.
    - a. For each proposed splice location provide written justification describing why the splice is necessary.
- D. Test reports:
  - 1. Submit test reports for meg-ohm tests.
- E. Calculations:
  - 1. Submit cable pulling calculations to the Engineer for review and comment for all cables that will be installed using mechanical pulling equipment. Show that the maximum cable tension and sidewall pressure will not exceed manufacturer recommended values:
    - a. Provide a table showing the manufacturer's recommended maximum cable tension and sidewall pressure for each cable type and size included in the calculations.
    - b. Submit the calculations to the Engineer a minimum of 2 weeks before conduit installation.

## **1.06 QUALITY ASSURANCE**

- A. As specified in Section 26\_05\_00.
- B. All wires and cables shall be UL listed and labeled.

## **1.07 DELIVERY, STORAGE, AND HANDLING**

- A. As specified in Section 26\_05\_00.

## **1.08 WARRANTY**

- A. As specified in Section 26\_05\_00.

## **1.09 SYSTEM START-UP**

- A. As specified in Section 26\_05\_00.

## **PART 2 PRODUCTS**

### **2.01 MANUFACTURERS**

- A. One of the following or equal:
  - 1. 600 volt class wire and cable:
    - a. General Cable.
    - b. Okonite Company.
    - c. Southwire Company.

2. Instrumentation class wire and cable:
  - a. Alpha Wire Company.
  - b. Belden CDT.
  - c. General Cable BICC Brand.
  - d. Okonite Company.
  - e. Rockbestos Surprenant Cable Corporation.
3. Network cables:
  - a. Belden CDT.
  - b. General Cable.
  - c. CommScope.

## 2.02 MATERIALS

- A. Conductors:
  1. Copper in accordance with ASTM B3.

## 2.03 MANUFACTURED UNITS

- A. General:
  1. Provide new wires and cables manufactured within 1 year of the date of delivery to the Site.
  2. Permanently mark each wire and cable with the following at 24-inch intervals:
    - a. AWG size.
    - b. Voltage rating.
    - c. Insulation type.
    - d. UL symbol.
    - e. Month and year of manufacture.
    - f. Manufacturer's name.
  3. Identify and mark wire and cable as specified in Section 26\_05\_53:
    - a.
- B. 600 volt class wire and cable:
  1. Provide AWG or kcmil sizes as indicated on the Drawings or in the Conduit Schedules:
    - a. When not indicated on the Drawings, size wire as follows:
      - 1) In accordance with the NEC:
        - a) Use 75 degree Celsius ampacity ratings.
        - b) Ampacity rating after all derating factors, equal to or greater than rating of the overcurrent device.
      - 2) Provide #12 AWG minimum for power conductors.
      - 3) Provide #14 AWG minimum for control conductors.
  2. Provide Class B stranding in accordance with ASTM B8:
    - a. Provide Class C stranding where extra flexibility is required.
  3. Insulation:
    - a. XHHW-2.
    - b. 90 degree Celsius rating.

4. Multiconductor cables:
  - a. Number and size of conductors as indicated on the Drawings or in the Conduit Schedules.
  - b. Individual conductors with XHHW-2 insulation.
  - c. Overall PVC jacket.
  - d. Tray cable rated.
  - e. Color-coding for control wire in accordance with ICEA Method 1, E-2 in accordance with NEMA WC 57/ICEA S-73-532.
  - f. Ground conductor: Insulated, green:
    - 1) Sized in accordance with NEC.
5. Instrumentation class cable (2CS).
6. Type TC.
7. Suitable for use in wet locations.
8. Voltage rating: 600 volts.
9. Temperature rating:
  - a. 90 degree Celsius rating in dry locations.
  - b. 75 degree Celsius rating in wet locations.
10. Conductors:
  - a. Insulation:
    - 1) Flame-retardant PVC, 15 mils nominal thickness, with nylon jacket 4 mils nominal thickness.
  - b. #16 AWG stranded and tinned.
  - c. Color code:
    - 1) Pair: Black and white.
    - 2) Triad: Black, white and red.
    - 3) Multiple pairs or triads:
      - a) Color-coded and numbered.
11. Drain wire:
  - a. #18 AWG.
  - b. Stranded, tinned.
12. Jacket:
  - a. Flame retardant, moisture and sunlight resistant PVC.
  - b. Ripcord laid longitudinally under jacket to facilitate removal.
13. Shielding:
  - a. Individual pair/triad:
    - 1) Minimum 1.35-mil double-faced aluminum foil-polyester tape overlapped to provide 100 percent coverage.
  - b. Multiple pair or triad shielding:
    - 1) Group shield: Minimum 1.35-mil double-faced aluminum foil-polyester tape overlapped to provide 100 percent coverage.
    - 2) Completely isolate group shields from each other.
    - 3) Cable shield: 2.35 mils double-faced aluminum and synthetic polymer backed tape overlapped to provide 100 percent coverage.
  - c. All shielding to be in contact with the drain wire.

- C. Network cables:
  - 1. Category 6:
    - a. General:
      - 1) Provide all Cat 6 cables meeting the standards set by TIA/EIA-568-C.2.
    - b. Conductors:
      - 1) #24 AWG solid bare copper conductors.
    - c. Insulation:
      - 1) Polyolefin.
      - 2) 4 non-bonded twisted pair cables formed into a cable core.
    - d. Color code:
      - 1) Pair 1: White/blue stripe and blue.
      - 2) Pair 2: White/orange stripe and orange.
      - 3) Pair 3: White/green stripe and green.
      - 4) Pair 4: White/brown stripe and brown.
    - e. Outer jacket:
      - 1) PVC with ripcord.
    - f. Electrical characteristics:
      - 1) Frequency range: 0.772-100 MHz.
      - 2) Attenuation: 32.1 dB/100 m.
      - 3) Near-end crosstalk (NEXT): 39.3 dB.
      - 4) Power sum NEXT: 37.3 dB.
      - 5) Attenuation to crosstalk ratio (ACR): 7.2 dB.
      - 6) Power sum attenuation to crosstalk ratio (PSACR): 5.3 dB/100 m.
      - 7) Equal level far-end crosstalk (ELFEXT): 22.8 dB.
      - 8) Power sum ELFEXT: 19.8 dB/100 m.
      - 9) Return loss: 17.3 dB.
      - 10) Propagation delay: 537 ns/100 m.
      - 11) Delay skew: 45 ns/100 m.
      - 12) Propagation delay (skew), max: 2.5 ns/100 m.

## 2.04 ACCESSORIES

- A. Wire ties:
  - 1. One of the following or equal:
    - a. T&B "Ty-Rap" cable ties.
    - b. Panduit cable ties.
- B. Wire markers:
  - 1. As specified in Section 26\_05\_53.

## 2.05 SOURCE QUALITY CONTROL

- A. Assembly and testing of cable shall comply with the applicable requirements of ICEA S-95-658-1999.
- B. Test Type XHHW-2 in accordance with the requirements of UL 44.

## PART 3 EXECUTION

### 3.01 INSTALLATION

- A. As specified in Section 26\_05\_00.
- B. Color-coding:
1. Color-coding shall be consistent throughout the facility.
  2. The following color code shall be followed for all 240/120 volt and 208/120 volt systems:
    - a. Phase A - Black.
    - b. Phase B - Red.
    - c. Phase C - Blue.
    - d. Single phase system - Black for one hot leg, red for the other.
    - e. Neutral - White.
    - f. High phase or wild leg - Orange.
    - g. Equipment ground - Green.
  3. The following color code shall be followed for all 480/277 volt systems:
    - a. Phase A - Brown.
    - b. Phase B - Orange.
    - c. Phase C - Yellow.
    - d. Neutral - Gray.
    - e. Equipment ground - Green.
  4. The following color code shall be followed for all 120 VAC control wiring:
    - a. Power - Red.
    - b. Neutral - White.
  5. The following color code shall be followed for all general purpose DC control circuits:
    - a. Grounded conductors - White with blue stripe.
    - b. Ungrounded conductors - Blue.
  6. Switch legs shall be violet. Three-way switch runners shall be pink.
  7. Wires in intrinsically safe circuits shall be light blue.
  8. Wire colors shall be implemented in the following methods:
    - a. Wires manufactured of the desired color.
    - b. Continuously spiral wrap the first 6 inches of the wire from the termination point with colored tape:
      - 1) Colored tape shall be wrapped to overlap 1/2 of the width of the tape.
- C. Install conductors only after the conduit installation is complete, and all enclosures have been vacuumed clean, and the affected conduits have been swabbed clean and dry:
1. Install wires only in approved raceways.
  2. Do not install wire:
    - a. In incomplete conduit runs.
    - b. Until after the concrete work and plastering is completed.

- D. Properly coat wires and cables with pulling compound before pulling into conduits:
1. For all #4 AWG and larger, use an approved wire-pulling lubricant while cable is being installed in conduit:
    - a. Ideal Products.
    - b. Polywater Products.
    - c. 3M Products.
    - d. Greenlee Products.
    - e. Or equal as recommended by cable manufacturer.
    - f. Do not use oil, grease, or similar substances.
- E. Cable pulling:
1. Prevent mechanical damage to conductors during installation.
  2. For cables #1 AWG and smaller, install cables by hand.
  3. For cables larger than #1 AWG, power pulling winches may be used if they have cable tension monitoring equipment.
  4. Provide documentation that maximum cable pulling tension was no more than 75 percent of the maximum recommended level as published by the cable manufacturer. If exceeded, the Engineer may, at his discretion, require replacement of the cable.
  5. Ensure cable pulling crews have all calculations and cable pulling limitations while pulling cable.
  6. Make splices or add a junction box or pullbox where required to prevent cable pulling tension or sidewall pressure from exceeding 75 percent of manufacturer's recommendation for the specified cable size:
    - a. Make splices in manholes or pull boxes only.
    - b. Leave sufficient slack to make proper connections.
- F. Use smooth-rolling sheaves and rollers when pulling cable into cable tray to keep pulling tension and bending radius within manufacturer's recommendations.
- G. Install and terminate all wire in accordance with manufacturer's recommendations.
- H. Neatly arrange and lace conductors in all switchboards, panelboards, pull boxes, and terminal cabinets by means of wire ties:
1. Do not lace wires in gutter or panel channel.
  2. Install all wire ties with a flush cutting wire tie installation tool:
    - a. Use a tool with an adjustable tension setting.
  3. Do not leave sharp edges on wire ties.
- I. Terminate stranded conductors on equipment box lugs such that all conductor strands are confined within the lug:
1. Use ring type lugs if box lugs are not available on the equipment.
- J. Lighting circuits:
1. Each circuit shall have a dedicated neutral.

- K. Splices:
1. Provide continuous circuits from origin to termination whenever possible:
    - a. Obtain Engineer's approval prior to making any splices.
  2. Lighting and receptacle circuit conductors may be spliced without prior approval from the Engineer.
  3. Where splices are necessary because of extremely long wire or cable lengths that exceed standard manufactured lengths:
    - a. Splice box NEMA rating requirements as specified in Section 26\_05\_00.
    - b. Make splices in labeled junction boxes for power conductors.
    - c. Make splices for control and instrument conductors in terminal boxes:
      - 1) Provide terminal boards with setscrew pressure connectors, with spade or ring lug connectors.
  4. Power and control conductors routed in common raceways may be spliced in common junction boxes.
  5. Clearly label junction and terminal boxes containing splices with the word "SPLICE LOCATED WITHIN".
  6. Leave sufficient slack at junction boxes and termination boxes to make proper splices and connections. Do not pull splices into conduits.
  7. Install splices with compression type butt splices and insulate using a heat-shrink sleeve:
    - a. In NEMA Type 4 or NEMA Type 4X areas, provide heat-shrink sleeves that are listed for submersible applications.
  8. Splices in below grade pull boxes, in any box subject to flooding, and in wet areas shall be made waterproof using:
    - a. A heat shrink insulating system listed for submersible applications.
    - b. Or an epoxy resin splicing kit.
- L. Apply wire markers to all wires at each end after being installed in the conduit and before meg-ohm testing and termination.
- M. Instrumentation class cable:
1. Install instrumentation class cables in separate raceway systems from power cables:
    - a. Install instrument cable in metallic conduit within non-dedicated manholes or pull boxes.
    - b. Install cable without splices between instruments or between field devices and instrument enclosures or panels.
  2. Do not make intermediate terminations, except in designated terminal boxes as indicated on the Drawings.
  3. Shield grounding requirements as specified in Section 26\_05\_26.
- N. Multi-conductor cable:
1. Where cable is not routed in conduit with a separate ground conductor, use one conductor in the cable as a ground conductor:
    - a) Use an internal ground conductor, if it is no smaller than as indicated on the Drawings and in accordance with NEC requirements for equipment ground conductor size.



- b) Where 2 parallel cables are used, and the internal ground conductor in each cable does not meet NEC requirements for the combined circuit, use 4-conductor cable, with one of the full-sized conductors serving as ground.
  
- O. Armored cable:
  - 1. Where 2 parallel cables are used, and the internal ground conductor in each cable does not meet NEC requirements for the combined circuit, use 4-conductor cable, with 1 of the full-sized conductors serving as ground.
  - 2. The cable armor is not acceptable as a ground conductor.
  - 3. Where armored cable terminates at a device, switchboard, panel, etc., use armored cable connector.
  - 4. Where armored cable run continues in conduit, strip jacket and armor for portions in conduit, and terminate cable and jacket with an armored cable connector threaded into a coupling or conduit box.
  
- P. Telephone cable:
  - 1. Install telephone cables in dedicated metallic raceways, including raceways in ductbanks, manholes, and pull boxes.
  
- Q. Fire alarm cable:
  - 1. Install fire alarm cable in dedicated metallic raceways as indicated on the Drawings.
  
- R. Signal cable:
  - 1. Separate and isolate electrical signal cables from sources of electrical noise and power cables by minimum 12 inches.
  
- S. Submersible cable in wet wells:
  - 1. Provide Kellem's grip or stainless steel wire mesh to support cable weight and avoid stress on insulation.
  
- T. Wiring allowances:
  - 1. Equipment locations may vary slightly from the drawings. Include an allowance for necessary conductors and terminations for motorized equipment, electrical outlets, fixtures, communication outlets, instruments, and devices within 10 linear feet of locations indicated on the Drawings.
  - 2. Locations for pull boxes, manholes, and duct banks may vary slightly from the drawings. Include an allowance for necessary conductors and related materials to provide conductors to all pull boxes, manholes and duct banks within 20 linear feet of locations indicated on the Drawings.

### 3.02 FIELD QUALITY CONTROL

- A. As specified in Section 26\_05\_00.
  
- B. Grounding:
  - 1. As specified in Section 26\_05\_26.

### **3.03 PROTECTION**

- A. As specified in Section 26\_05\_00.

## **PART 4 MEASUREMENT**

### **4.01 METHOD OF MEASUREMENT**

- A. No separate measurement shall be made for work under this Section.

## **PART 5 PAYMENT**

### **5.01 METHOD OF PAYMENT**

- A. No separate payment will be made for work under this Section. The cost of the work described in this Section shall be included in the applicable lump sum bid item.

END OF SECTION



## SECTION 26\_05\_21

### LOW VOLTAGE WIRE CONNECTIONS

#### PART 1 GENERAL

##### 1.01 SUMMARY

- A. Section includes:
  - 1. Wire connecting devices.
  - 2. Terminations.
  - 3. Splices.
- B. Related sections:
  - 1. Section 26\_05\_00 - Common Work Results for Electrical.
  - 2. Section 26\_05\_18 - 600-Volt or Less Wires and Cables.

##### 1.02 REFERENCES

- A. As specified in Section 26\_05\_00.
- B. ASTM International (ASTM):
  - 1. D3005 - Standard Specification for Low-Temperature Resistant Vinyl Chloride Plastic Pressure-Sensitive Electrical Insulating Tape.
- C. CSA International (CSA):
  - 1. C22.2 - No.197-M1983 (R2208) - PVC Insulating Tape.
- D. Underwriters Laboratories, Inc. (UL):
  - 1. 510 - Standard for Polyvinyl Chloride, Polyethylene, and Rubber Insulating Tape.

##### 1.03 DEFINITIONS

- A. As specified in Section 26\_05\_00.

##### 1.04 SYSTEM DESCRIPTION

- A. Provide a complete system of wiring connectors, terminators, fittings, etc. for a complete wiring system suitable for the cables and conductors used.

##### 1.05 SUBMITTALS

- A. Furnish submittals as specified in Section 26\_05\_00.
- B. Product data:
  - 1. Catalog cut sheets.

2. Installation instructions.

### **1.06 QUALITY ASSURANCE**

- A. As specified in Section 26\_05\_00.
- B. All materials shall be UL listed.

### **1.07 DELIVERY, STORAGE, AND HANDLING**

- A. As specified in Section 26\_05\_00.

### **1.08 PROJECT OR SITE CONDITIONS**

- A. As specified in Section 26\_05\_00.

### **1.09 WARRANTY**

- A. As specified in Section 26\_05\_00.

### **1.10 SYSTEM START-UP**

- A. As specified in Section 26\_05\_00.

## **PART 2 PRODUCTS**

### **2.01 MANUFACTURERS**

- A. Manufacturers for each type of technology are specified with the equipment in this Section.

### **2.02 EQUIPMENT**

- A. Control connections:
  1. Use insulated ring type wire terminators for connections to all screw terminals:
    - a. With chamfered/funneled terminal barrel entry.
    - b. Deep internal serrations.
    - c. Long barrel design to reduce electrical resistance and increased insulator-barrel surface area to ensure that the insulator remains in contact with the barrel.
    - d. Electroplated-tin copper conductor.
    - e. Manufacturer: The following or equal:
      - 1) Thomas and Betts, Stakon.
  2. For process equipment connections work from manufacturer's drawings.
- B. Joints, splices, taps, and connections:
  1. 600-volt conductors:
    - a. Use solderless connectors.

- b. Use only plated copper alloy connectors or lugs:
    - 1) Aluminum connectors or lugs are not acceptable for copper conductors.
  - c. Under those specific conditions where aluminum conductors have been allowed or are specified then the connectors for aluminum conductors shall be specifically designed for that purpose.
  - d. For wire Number 10 AWG and smaller use compression splice caps, with insulating caps:
    - 1) Manufacturer: The following or equal:
      - a) Buchanan 2006S or 2011S, with 2007 or 2014 insulating caps.
  - e. For wire Number 8 AWG and larger, use heavy duty copper compression connectors:
    - 1) Manufacturer: One of the following or equal:
      - a) Burndy.
      - b) Thomas and Betts.
  - f. Heat shrink tubing:
    - 1) Suitable for indoors, outdoors, overhead, direct burial or submerged applications.
    - 2) Minimum shrink ratio: 4 to 1.
    - 3) Continuous operating temperature: -55 degrees Celsius to 110 degrees Celsius.
    - 4) Internally applied adhesive sealant.
    - 5) Cross-linked polyolefin:
      - a) Manufacturers, one of the following or equal:
        - (1) 3M ITCSN.
        - (2) Thomas & Betts Shrink-Kon.
2. Instrumentation class cable splices:
- a. Suitable for indoor, outdoors, weather exposed, direct buried, or submersed applications.
  - b. Utilizing an epoxy, polyurethane, and re-enterable compounds.
  - c. For use with shielded or unshielded plastic- and rubber-jacketed, signal, control, and power cables rated up to 1 kilovolt.
  - d. Two-part mold body with tongue and groove seams and built in spacer webbing.
  - e. Manufacturer: The following or equal:
    - 1) 3M - Scotchcast 72-N.
- C. Insulating tape:
- 1. General purpose insulating tape:
    - a. Minimum 7 mil vinyl tape.
    - b. Suitable for application in an ambient of -18 degrees Celsius (0 degrees Fahrenheit).
    - c. Operating range up to 105 degrees Celsius (220 degrees Fahrenheit).
    - d. Flame retardant, hot- and cold- weather resistant, UV resistant.
    - e. For use as a primary insulation for wire cable splices up to 600 VAC.
    - f. Meeting and complying with:
      - 1) ASTM D3005 Type I.

- 2) UL 510.
- 3) CSA C22.2.
- g. Manufacturer: The following or equal:
  - 1) 3M - Scotch Number Super 33+.
2. General-purpose color-coding tape:
  - a. Minimum 7 mil vinyl tape.
  - b. Suitable for application on PVC and polyethylene jacketed cables.
  - c. For use indoors and outdoors in weather protected enclosures.
  - d. Available with the following colors:
    - 1) Red.
    - 2) Yellow.
    - 3) Blue.
    - 4) Brown.
    - 5) Gray.
    - 6) White.
    - 7) Green.
    - 8) Orange.
    - 9) Violet.
  - e. For use as phase identification, marking, insulating, and harnessing.
  - f. Meeting and complying with:
    - 1) UL 510.
    - 2) CSA C22.2.
  - g. Manufacturer the following or equal:
    - 1) 3M - Scotch Number 35.

## **PART 3 EXECUTION**

### **3.01 INSTALLATION**

- A. As specified in Section 26\_05\_00.
- B. Load connections:
  1. Connect loads to the circuits as indicated. Color-code all branch circuits as specified in Section 26\_05\_18.
- C. Zero to 600-volt systems:
  1. Make all connections with the proper tool and die as specified by the device manufacturer.
  2. Use only tooling and dies manufactured by the device manufacturer.
  3. Insulate all connections and splices with Scotch 33+ tape and Scotchfill, or pre-molded plastic covers, or heat shrink tubing and caps.
  4. Number all power and control wires before termination.
- D. Motor connections (600 volts and below):
  1. Terminate all leads and wires with compression type ring lugs.

2. Terminations on all motor leads, including leads that are connected together to accommodate the motor voltage, and the machine wires entering the motor terminal box from the power source, shall have ring type compression lugs.
3. Cover bolted connectors with a heat shrinkable, cross-linked polyolefin material formed as a single opening boot:
  - a. In damp and wet locations, use a complete kit containing mastic that shall seal out moisture and contamination.
  - b. Shrink cap with low heat as recommended by manufacturer.
4. Wire markers shall be readable after boot installation.
5. Manufacturer: The following or equal:
  - a. Raychem MCK.

### **3.02 FIELD QUALITY CONTROL**

- A. As specified in Section 26\_05\_00.

### **3.03 PROTECTION**

- A. As specified in Section 26\_05\_00.

## **PART 4 MEASUREMENT**

### **4.01 METHOD OF MEASUREMENT**

- A. No separate measurement shall be made for work under this Section.

## **PART 5 PAYMENT**

### **5.01 METHOD OF PAYMENT**

- A. No separate payment will be made for work under this Section. The cost of the work described in this Section shall be included in the applicable lump sum bid item.

END OF SECTION





## SECTION 26\_05\_26

### GROUNDING AND BONDING

#### PART 1 GENERAL

##### 1.01 SUMMARY

- A. Section includes:
  - 1. Grounding materials and requirements.
- B. Related sections:
  - 1. Section 26\_05\_00 - Common Work Results for Electrical.
  - 2. Section 26\_08\_50 - Field Electrical Acceptance Tests.

##### 1.02 REFERENCES

- A. As specified in Section 26\_05\_00.
- B. ASTM International (ASTM):
  - 1. B3 - Standard Specification for Soft or Annealed Copper Wire.
  - 2. B8 - Standard Specification for Concentric-Lay-Stranded Copper Conductors, Hard, Medium-Hard, or Soft.
- C. Institute of Electrical and Electronics Engineers (IEEE):
  - 1. 81 - IEEE Guide for Measuring Earth Resistivity, Ground Impedance, and Earth Surface Potentials of a Grounding System.
- D. Underwriters Laboratories, Inc. (UL):
  - 1. 467 - Ground and Bonding Equipment.

##### 1.03 DEFINITIONS

- A. As specified in Section 26\_05\_00.

##### 1.04 SYSTEM DESCRIPTION

- A. Ground equipment and raceway systems so that the completed installation conforms to all applicable code requirements.
- B. Provide a complete electrical grounding system as indicated on the Drawings and as specified including but not limited to:
  - 1. Grounding electrodes.
  - 2. Bonding jumpers.
  - 3. Ground connections.

- C. Provide bonding jumpers and wire, grounding bushings, clamps and appurtenances required for complete grounding system to bond equipment and raceways to equipment grounding conductors.
- D. The ground system resistance (electrode to ground) of the completed installation, as determined by tests specified in Section 26\_08\_50, shall be:
  - 1. 5 ohms or less for industrial systems.
  - 2. 1 ohm or less for electrical buildings.

### **1.05 SUBMITTALS**

- A. Furnish submittals as specified in Section 26\_05\_00.
- B. Product data:
  - 1. Catalog cut sheets.

### **1.06 QUALITY ASSURANCE**

- A. As specified in Section 26\_05\_00.
- B. All grounding components and materials shall be UL listed and labeled.

### **1.07 DELIVERY, STORAGE, AND HANDLING**

- A. As specified in Section 26\_05\_00.

### **1.08 WARRANTY**

- A. As specified in Section 26\_05\_00.

### **1.09 SYSTEM START-UP**

- A. As specified in Section 26\_05\_00.

## **PART 2 PRODUCTS**

### **2.01 MANUFACTURERS**

- A. Compression connectors: One of the following or equal:
  - 1. FCI Burndy.
  - 2. Thomas & Betts.
- B. Exothermic connectors: One of the following or equal:
  - 1. Erico.
  - 2. Harger.
  - 3. Burndy Weld.

- C. Ground rods: One of the following or equal:
  - 1. Erico.
  - 2. Harger.
  - 3. Conex.
  
- D. Ground cable: One of the following or equal:
  - 1. Nehring.
  - 2. Harger.
  - 3. Southwire.
  
- E. Precast ground well boxes: One of the following or equal:
  - 1. Brooks Products, 3-RT Valve Box.
  - 2. Christy Concrete Products, G12 Valve Box.

## 2.02 MATERIALS

- A. Ground rod:
  - 1. Minimum: 3/4-inch diameter, 10 feet long.
  - 2. Uniform 10 mil covering of electrolytic copper metallicity bonded to a rigid steel core:
    - a. The copper-to-steel bond shall be corrosion resistant.
  - 3. In accordance with UL 467.
  - 4. Sectional type joined by threaded copper alloy couplings.
  - 5. Fit the top of the rod with a threaded coupling and steel-driving stud.
  
- B. Ground cable:
  - 1. Requirements:
    - a. Soft drawn (annealed).
    - b. Concentric lay, coarse stranded in accordance with ASTM B8.
    - c. Bare copper in accordance with ASTM B3.
  - 2. Size is as indicated on the Drawings, but not less than required by the NEC.
  
- C. Compression connectors:
  - 1. Manufactured of high copper alloy specifically for the particular grounding application.
  - 2. Suitable for direct burial in earth and concrete.
  - 3. Identifying compression die number inscription to be impressed on compression fitting.
  
- D. Equipment grounding conductors:
  - 1. Conductors shall be the same type and insulation as the load circuit conductors:
    - a. Use 600-volt insulation for the equipment grounding conductors for medium voltage systems.
  - 2. Minimum size in accordance with the NEC.
  
- E. Grounding electrode conductors:
  - 1. Minimum size in accordance with the NEC.

- F. Main bonding jumpers and bonding jumpers:
  - 1. Minimum size in accordance with the NEC.

## 2.03 ACCESSORIES

- A. Precast ground well boxes:
  - 1. Minimum 10 inch interior diameter.
  - 2. Traffic-rated cast iron cover.
  - 3. Permanent "GROUND" marking on cover.

## PART 3 EXECUTION

### 3.01 INSTALLATION

- A. As specified in Section 26\_05\_00.
- B. Provide a separate, green insulated, grounding conductor in each raceway independent of raceway material:
  - 1. Multi-conductor power and control cables shall include an integral green insulated grounding conductor.
  - 2. Provide a separate grounding conductor in each individual raceway for parallel feeders.
- C. Provide a separate grounding conductor for each motor and connect at motor terminal box. Do not use bolts securing motor box to frame or cover for grounding connectors:
  - 1. When grounding motors driven by variable frequency drives (VFD) comply with the requirements of the VFD manufacturer.
- D. Provide a grounding type bushing with lug for connection of grounding conductor for conduits that originate from each motor control center section, switchboard, or panelboard:
  - 1. Individually bond these raceways to the ground bus in the equipment.
- E. Provide grounding type bushings with lugs for connection of grounding conductor at both ends of metallic conduit runs. Bond ground bushings to the grounding system.
- F. Provide a green insulated wire-grounding jumper from the ground screw to a box grounding screw and, for grounding type devices, to equipment grounding conductor.
- G. Interconnect the secondary switchgear, switchboard, or panelboard neutral bus to the ground bus in the secondary switchgear, switchboard, or panelboard compartment, only at service entrance point or after a transformer.

- H. Duct bank ground system:
1. Provide a bare copper grounding conductor the entire length of each duct bank, embedded in the concrete of the duct bank as indicated on the Drawings and specified in the Specifications.
  2. Bond duct bank ground conductors together where duct banks join, merge, intersect, or split.
- I. Grounding at service (600 V or Less):
1. Connect the neutral to ground only at one point within the enclosure of the first disconnecting means on the load side of the service transformer.
- J. Ground connections:
1. All connections to the ground grid system, the duct bank grounding system, equipment, ground rods, etc., shall be made using compression type grounding connectors as indicated on the Drawings, UL listed, and labeled for the application.
  2. Make ground connections in accordance with the manufacturer's instructions.
  3. Do not conceal or cover any ground connections until the Engineer or authorized representative has established and provided written confirmation that every grounding connection is as indicated on the Drawings and specified in the Specifications.
- K. Grounding electrode system:
1. Ground ring:
    - a. Provide all trenching and materials necessary to install the ground ring as indicated on the Drawings.
    - b. Ground ring conductor shall be in direct contact with the earth, or where embedded, concrete, of the size as indicated on the Drawings.
    - c. Minimum burial depth 36 inches or as indicated on the Drawings.
    - d. Re-compact disturbed soils to original density in 6-inch lifts.
  2. Ground rods:
    - a. Locations as indicated on the Drawings.
    - b. Length of rods forming an individual ground array shall be equal in length.
    - c. Drive ground rods and install grounding conductors before construction of concrete slabs and duct banks.
  3. Metal underground water pipe:
    - a. Bond metal underground domestic water pipe to grounding electrode system.
  4. Metal frame of building or structure:
    - a. Bond metal frame of building or structure to grounding electrode system.
  5. Extend grounding conductors through concrete to accessible points for grounding equipment and electrical enclosures.
  6. Where grounding conductors are not concrete-encased or direct buried, install in Schedule 40 PVC conduit for protection.
  7. Install grounding system at each structure where switchgear, motor control centers, switchboards, panelboards, panels, or other electrical equipment are installed.

- L. Shield grounding:
  - 1. Shielded instrumentation cable shall have its shield grounded at one end only unless shop drawings indicate otherwise:
    - a. The grounding point shall be at the control panel or at the power source end of the signal carried by the cable.
  - 2. Terminate the shield drain wire on a dedicated terminal block.
  - 3. Use manufacturer's terminal block jumpers to interconnect ground terminals.
  - 4. Connection to the panel main ground bus shall be via a green No. 12 conductor to the main ground bus for the panel.
  
- M. Where indicated on the Drawings, install ground rods in precast ground wells.

### **3.02 FIELD QUALITY CONTROL**

- A. As specified in Section 26\_05\_00.
  
- B. Measure grounding electrode system resistance to ground in accordance with IEEE 81.

### **3.03 ADJUSTING**

- A. Under the direction of the Engineer, add additional parallel connected ground rods and/or deeper driven rods until the ground resistance measurement meets the specified resistance requirements:
  - 1. Use of salts, water, or compounds to attain the specified ground resistance is not acceptable.

### **3.04 PROTECTION**

- A. As specified in Section 26\_05\_00.

## **PART 4 MEASUREMENT**

### **4.01 METHOD OF MEASUREMENT**

- A. No separate measurement shall be made for work under this Section.

## **PART 5 PAYMENT**

### **5.01 METHOD OF PAYMENT**

- A. No separate payment will be made for work under this Section. The cost of the work described in this Section shall be included in the applicable lump sum bid item.

END OF SECTION

## SECTION 26\_05\_29

### HANGERS AND SUPPORTS

#### PART 1 GENERAL

##### 1.01 SUMMARY

- A. Section includes:
  - 1. Mounting and supporting electrical equipment and components.
- B. Related sections:
  - 1. Section 05\_05\_24 - Mechanical Anchoring And Fastening To Concrete And Masonry.
  - 2. Section 09\_91\_00 - Painting.
  - 3. Section 26\_05\_00 - Common Work Results for Electrical.

##### 1.02 REFERENCES

- A. As specified in Section 26\_05\_00.
- B. ASTM International (ASTM):
  - 1. A123 - Standard Specification for Zinc (Hot-Dip Galvanized) Coatings on Iron and Steel Products.
  - 2. A153 - Standard Specification for Zinc Coating (Hot-Dip) on Iron and Steel Hardware.
  - 3. A240 - Standard Specification for Chromium and Chromium-Nickel Stainless Steel Plate, Sheet, and Strip for Pressure Vessels and for General Applications.

##### 1.03 DEFINITIONS

- A. As specified in Section 26\_05\_00.

##### 1.04 SYSTEM DESCRIPTION

- A. Design requirements:
  - 1. Conform to the requirements of the Building Code.
  - 2. Demonstrate the following using generally accepted engineering methods:
    - a. That the anchors to the structure are adequate to resist the loads generated in accordance with the Building Code and equipment requirements.
    - b. That the required load capacity of the anchors can be fully developed in the structural materials to which they are attached.
  - 3. Design loading and anchoring requirements:
    - a. As indicated in the Building Code unless otherwise specified.



- b. Seismic loading requirements:
    - 1) Freestanding, suspended or wall-hung equipment shall be anchored in place by methods that will satisfy the requirements for the seismic design specified in Section 26\_05\_00.
  - c. Wind loading requirements:
    - 1) All exterior equipment shall be anchored in place by methods that will satisfy the requirements for wind design specified in Section 26\_05\_00.
  - d. Minimum safety factor against overturning: 1.5.
  - e. The foundation and structures to which hangers and supports are attached shall be capable of withstanding all anchor loads.
- B. Performance requirements:
- 1. Hangers and supports individually and as a system shall resist all weights and code-required forces without deflections and deformations that would damage the supporting elements, the equipment supported, or the surrounding construction.

## 1.05 SUBMITTALS

- A. Furnish submittals as specified in Section 26\_05\_00.
- B. Product data:
- 1. Supports:
    - a. Materials.
    - b. Geometry.
    - c. Manufacturer.
  - 2. Hardware:
    - a. Materials.
    - b. Manufacturer.
- C. Shop drawings:
- 1. Complete dimensioned and scalable shop drawings of all supporting structures, trapezes, wall supports, etc.
  - 2. Complete anchoring details for equipment, lighting and raceway, supporting structures, trapezes, wall supports for all equipment in excess of 200 pounds, and all freestanding supports:
    - a. Stamped by a professional engineer licensed in the state where the Project is being constructed.
    - b. Said submittals, by virtue of the fact that they bear the stamp of a registered engineer, will be reviewed for general consistency with the requirements specified in the Contract Documents, but not for context, accuracy, or method of calculation.
  - 3. Include data on attachment hardware and construction methods that will satisfy the design loading and anchoring criteria.

- D. Installation instructions:
  - 1. Furnish anchorage instructions and requirements based on the seismic and wind conditions of the Site:
    - a. Stamped by a professional engineer licensed in the state where the Project is being constructed.

## **1.06 QUALITY ASSURANCE**

- A. As specified in Section 26\_05\_00.

## **1.07 DELIVERY, STORAGE, AND HANDLING**

- A. As specified in Section 26\_05\_00.

## **1.08 PROJECT OR SITE CONDITIONS**

- A. As specified in Section 26\_05\_00.

## **1.09 WARRANTY**

- A. As specified in Section 26\_05\_00.

## **1.10 SYSTEM STARTUP**

- A. As specified in Section 26\_05\_00.

## **PART 2 PRODUCTS**

### **2.01 MANUFACTURERS**

- A. One of the following or equal:
  - 1. Thomas & Betts.
  - 2. Power-Strut.
  - 3. Unistrut.
  - 4. Cooper B-Line.
  - 5. Robroy.
  - 6. Aickinstrut.

### **2.02 MATERIALS**

- A. Use materials appropriate for the area as specified in Section 26\_05\_00.
- B. Hot dip galvanized steel:
  - 1. Supports:
    - a. In accordance with ASTM A123 or A153.
    - b. Minimum zinc coating thickness of 2.5 mils.
  - 2. Hardware:
    - a. Electro-galvanized.

- b. In accordance with ASTM A153.
- C. Stainless steel:
  - 1. Supports:
    - a. In accordance with ASTM A240.
    - b. ANSI Type 316 material.
  - 2. Hardware:
    - a. ANSI Type 316 material.
- D. PVC coated galvanized steel:
  - 1. Supports:
    - a. Hot dip galvanized steel as specified in this Section.
    - b. PVC coating thickness of 10 to 20 mils.
  - 2. Hardware:
    - a. ANSI Type 316 material.
- E. Fiberglass:
  - 1. Supports:
    - a. Vinyl ester.
  - 2. Hardware:
    - a. Polypropylene.
    - b. Thermal plastic elastomer.
    - c. Fiberglass reinforced plastic.

## 2.03 ACCESSORIES

- A. Anchor bolts:
  - 1. As specified in Section 05\_05\_24.

## 2.04 FINISHES

- A. Paint and finish all supporting structures as specified in Section 09\_91\_00.

## PART 3 EXECUTION

### 3.01 INSTALLATION

- A. As specified in Section 26\_05\_00.
- B. Mount all raceways, cabinets, boxes, fixtures, instruments, and devices on Contractor-fabricated racks unless otherwise indicated on the Drawings.
  - 1. Provide the necessary sway bracing to keep trapeze type structures from swaying under seismic events or wind loading.

- C. Brace and anchor freestanding equipment supports using methods that provide structural support based on the seismic loads and wind loads:
  - 1. Lateral deflection at top of supports not to exceed support height divided by 240 unless otherwise approved by the Engineer.
  
- D. Provide fabricated steel support pedestals for wall mounted panels that weigh more than 200 pounds:
  - 1. Fabricate pedestals out of welded angle, tube sections, or preformed channel.
  - 2. If the supported equipment is a panel or cabinet, match the supported equipment in physical appearance and dimensions.
  - 3. Provide auxiliary floor supports for transformers hung from stud walls and weighing more than 200 pounds.
  - 4. Mount all equipment, cabinets, boxes, instruments, and devices in damp or wet locations on minimum of 7/8-inch preformed mounting channel.
    - a. Mount channel vertically along the length of the device so that water or moisture may run freely behind the device.
  
- E. Corrosion protection:
  - 1. Isolate dissimilar metals, except where required for electrical continuity.
    - a. Use neoprene washers, 9-mil polyethylene tape, or gaskets for isolation.
  
- F. Raceway:
  - 1. Furnish all racks and trapeze structures needed to support the raceway from the structure.
    - a. Group raceway and position on racks to minimize crossovers.
    - b. Provide the necessary bracing to keep trapeze type structures from swaying under loads from cable installation, seismic forces, or wind forces.
  
- G. Anchoring methods:
  - 1. Solid concrete: Anchor bolts, anchor rods or post-installed anchors as specified in Section 05\_05\_24.
  - 2. Metal surfaces: Machine screws or bolts.
  - 3. Hollow masonry units: Post-installed anchors as specified in Section 05\_05\_24.
  
- H. Recoat or seal all drilled holes, cut or scratched surfaces or with products recommended by the manufacturer.

### **3.02 FIELD QUALITY CONTROL**

- A. As specified in Section 26\_05\_00.

### **3.03 PROTECTION**

- A. As specified in Section 26\_05\_00.

## **PART 4 MEASUREMENT**

### **4.01 METHOD OF MEASUREMENT**

- A. No separate measurement shall be made for work under this Section.

## **PART 5 PAYMENT**

### **5.01 METHOD OF PAYMENT**

- A. No separate payment will be made for work under this Section. The cost of the work described in this Section shall be included in the applicable lump sum bid item.

END OF SECTION

## SECTION 26\_05\_33

### CONDUITS

#### PART 1 GENERAL

##### 1.01 SUMMARY

- A. Section includes:
  - 1. Metallic conduits.
  - 2. Nonmetallic conduits.
  - 3. Conduit bodies.
  - 4. Conduit fittings and accessories.
  - 5. Conduit installation.
  
- B. Related sections:
  - 1. Section 26\_05\_00 - Common Work Results for Electrical.
  - 2. Section 26\_05\_29 - Hangers and Supports.
  - 3. Section 26\_05\_53 - Identification for Electrical Systems.
  - 4. Section 26\_05\_44 - Duct Banks.

##### 1.02 REFERENCES

- A. As specified in Section 26\_05\_00.
  
- B. American National Standards Institute (ANSI):
  - 1. C80.1 - Electrical Rigid Steel Conduit.
  - 2. C80.3 - Steel Electrical Metallic Tubing.
  - 3. C80.5 - Electrical Rigid Aluminum Conduit.
  - 4. C80.6 - Electrical Intermediate Metal Conduit.
  
- C. National Electrical Manufacturer's Association (NEMA):
  - 1. RN-1 - Polyvinyl Chloride (PVC) Externally Coated Galvanized Rigid Steel Conduit and Intermediate Steel Conduit.
  - 2. TC2 - Electrical Polyvinyl Chloride (PVC) Conduit.
  - 3. TC3 - Polyvinyl Chloride (PVC) Fittings for Use with Rigid PVC Conduit and Tubing.
  - 4. TC7 - Smooth-Wall Coilable Electrical Polyethylene Conduit.
  - 5. TC13 - Electrical Nonmetallic Tubing.
  - 6. TC14 - Reinforced Thermosetting Resin Conduit (RTRC) and Fittings.
  
- D. Underwriters Laboratories (UL):
  - 1. 1 - Standard for Flexible Metal Conduit.
  - 2. 6 - Standard for Electrical Rigid Metal Conduit - Steel.
  - 3. 6A - Standard for Electrical Rigid Metal Conduit - Aluminum, Red Brass, and Stainless Steel.

4. 360 - Standard for Liquidtight Flexible Steel Conduit.
5. 651 - Standard for Schedule 40 and 80 Rigid PVC Conduit and Fittings.
6. 651B - Standard for Continuous Length HDPE Conduit.
7. 797 - Standard for Electrical Metallic Tubing - Steel.
8. 1242 - Standard for Electrical Intermediate Metal Conduit - Steel.
9. 1653 - Standard for Electrical Nonmetallic Tubing.
10. 1660 - Standard for Liquidtight Flexible Nonmetallic Conduit.
11. 1684 - Standard for Reinforced Thermosetting Resin Conduit (RTRC) and Fittings.

### 1.03 DEFINITIONS

- A. As specified in Section 26\_05\_00.
- B. Specific definitions and abbreviations:
  1. Conduit bodies: A separate portion of a conduit system that provides access through a removable cover to the interior of the system at a junction of 2 or more conduit sections. Includes, but not limited to, Shapes C, E, LB, T, X, etc.
  2. Conduit fitting: An accessory that primarily serves a mechanical purpose. Includes, but not limited to, bushings, locknuts, hubs, couplings, reducers, etc.
  3. GRC: Galvanized rigid steel conduit.
  4. PCS: Polyvinyl chloride (PVC) coated rigid steel conduit.
  5. PCA: Polyvinyl chloride (PVC) coated rigid aluminum conduit.
  6. IMC: Intermediate metallic conduit.
  7. EMT: Electrical metallic tubing.
  8. PVC: Polyvinyl chloride rigid nonmetallic conduit.
  9. HDPE: High-density polyethylene conduit.
  10. SLT: Sealtight-liquidtight flexible conduit.
  11. EFLX: Explosion proof flexible conduit.
  12. FLX: Flexible metallic conduit.
  13. NFC: Nonmetallic flexible conduit.
  14. ENT: Electrical nonmetallic tubing.
  15. RAC: Rigid aluminum conduit.
  16. FRD: Fiberglass-reinforced duct.
  17. NPT: National pipe thread.

### 1.04 SYSTEM DESCRIPTION

- A. Provide conduits, conduit bodies, fittings, junction boxes, and all necessary components, whether or not indicated on the Drawings, as required, to install a complete electrical raceway system.

### 1.05 SUBMITTALS

- A. Furnish submittals as specified in Section 26\_05\_00.

- B. Product data:
  - 1. Furnish complete manufacturer's catalog sheets for every type and size of conduit, fitting, conduit body, and accessories to be used on the Project.
  - 2. Furnish complete manufacturer's recommended special tools to be used for installation if required.
- C. Certifications:
  - 1. Furnish PVC-coated conduit manufacturer's certification for each installer.
- D. Record Documents:
  - 1. Incorporate all changes in conduit routing on electrical plan drawings.
  - 2. Dimension underground and concealed conduits from building lines.
  - 3. Furnish hard copy drawings and electronic files in AutoCAD format  
Version: 2004.

### **1.06 QUALITY ASSURANCE**

- A. As specified in Section 26\_05\_00.
- B. All conduits, conduit bodies, and fittings shall be UL listed and labeled.

### **1.07 DELIVERY, STORAGE, AND HANDLING**

- A. As specified in Section 26\_05\_00.
- B. Do not expose Type PVC, FRD, NFC, and ENT to direct sunlight.
- C. Do not store conduit in direct contact with the ground.

### **1.08 PROJECT OR SITE CONDITIONS**

- A. As specified in Section 26\_05\_00.

### **1.09 SEQUENCING**

- A. Before installing any conduit or locating any device box:
  - 1. Examine the complete set of Drawings and Specifications, and all applicable shop drawings.
  - 2. Verify all dimensions and space requirements and make any minor adjustments to the conduit system as required to avoid conflicts with the building structure, other equipment, or the work of other trades.

### **1.10 WARRANTY**

- A. As specified in Section 26\_05\_00.

### **1.11 SYSTEM START-UP**

- A. As specified in Section 26\_05\_00.



## PART 2 PRODUCTS

### 2.01 MANUFACTURERS

- A. Galvanized rigid steel conduit:
  - 1. One of the following or equal:
    - a. Western Tube and Conduit.
    - b. Allied Tube and Conduit.
    - c. Wheatland Tube Co.
  
- B. PVC-coated rigid steel conduit:
  - 1. One of the following or equal:
    - a. Robroy Industries.
    - b. Ocal, Inc.
    - c. Calbond.
  
- C. Sealtight-liquidtight flexible conduit:
  - 1. One of the following or equal:
    - a. Southwire.
    - b. AFC Cable Systems.
    - c. Electri-Flex Company.
    - d. Anaconda.
  
- D. Rigid nonmetallic PVC conduit:
  - 1. One of the following or equal:
    - a. Carlon.
    - b. Cantex.
    - c. Triangle Conduit and Cable.
  
- E. Conduit bodies:
  - 1. One of the following or equal:
    - a. Crouse-Hinds.
    - b. Appleton.
    - c. O-Z/Gedney.
    - d. Ocal, Inc.
    - e. Robroy Industries.
    - f. Calbond.
    - g. Carlon.
  
- F. Joint compound:
  - 1. Thomas and Betts.
  
- G. Galvanized rigid steel conduit expansion fittings:
  - 1. One of the following or equal:
    - a. Crouse-Hinds.
    - b. Appleton.
    - c. O-Z/Gedney.

- H. Conduit sleeve:
  - 1. One of the following or equal:
    - a. Crouse-Hinds.
    - b. Appleton.
    - c. O-Z/Gedney.
- I. Conduit hangers and supports:
  - 1. As specified in Section 26\_05\_29.
- J. Conduit through wall and floor seals:
  - 1. The following or equal:
    - a. O-Z/Gedney:
      - 1) Type "WSK."
      - 2) Type "CSM."

## 2.02 COMPONENTS

- A. GRC:
  - 1. All threads: NPT standard conduit threads with a 3/4-inch taper per foot:
    - a. Running conduit threads are not acceptable.
  - 2. Hot-dip galvanized inside and out:
    - a. Ensures complete coverage and heats the zinc and steel to a temperature that ensures the zinc alloys with the steel over the entire surface.
    - b. Electro-galvanizing is not acceptable.
  - 3. Manufactured in accordance with:
    - a. UL-6.
    - b. ANSI C80.1.
- B. PCS:
  - 1. The steel conduit, before PVC coating, shall be new, unused, hot-dip galvanized material, conforming to the requirements for Type GRC.
  - 2. Coated conduit NEMA Standard RN-1:
    - a. The galvanized coating may not be disturbed or reduced in thickness during the cleaning and preparatory process.
  - 3. Factory-bonded PVC jacket:
    - a. The exterior galvanized surfaces shall be coated with primer before PVC coating to ensure a bond between the zinc substrate and the PVC coating.
    - b. Nominal thickness of the exterior PVC coating shall be 0.040 inch except where part configuration or application of the piece dictates otherwise.
    - c. PVC coating on conduits and associated fittings shall have no sags, blisters, lumps, or other surface defects and shall be free of holes and holidays.
    - d. The PVC adhesive bond on conduits and fittings shall be greater than the tensile strength of the PVC plastic coating:
      - 1) Confirm bond with certified test results.

4. A urethane coating shall be uniformly and consistently applied to the interior of all conduits and fittings:
    - a. Nominal thickness of 0.002 inch.
    - b. Conduits having areas with thin or no coating are not acceptable.
    - c. All threads shall be coated with urethane.
  5. The PVC exterior and urethane interior coatings applied to the conduits shall afford sufficient flexibility to permit field bending without cracking or flaking at temperature above 30 degrees Fahrenheit (-1 degree Celsius).
  6. PCS conduit bodies and fittings:
    - a. Malleable iron.
    - b. The conduit body, before PVC coating, shall be new, unused material and shall conform to appropriate UL standards.
    - c. The PVC coating on the outside of conduit bodies shall be 0.040-inch thick and have a series of longitudinal ribs to protect the coating from tool damage during installation.
    - d. 0.002-inch interior urethane coating.
    - e. Utilize the PVC coating as an integral part of the gasket design.
    - f. Stainless steel cover screw heads shall be encapsulated with plastic to ensure corrosion protection.
    - g. A PVC sleeve extending 1 conduit diameter or 2 inches, whichever is less, shall be formed at each female conduit opening.
      - 1) The inside diameter of the sleeve shall be the same as the outside diameter of the conduit to be used.
      - 2) The sleeve shall provide a vapor- and moisture-tight seal at every connection.
- C. SLT:
1. Temperature rated for use in the ambient temperature at the installed location but not less than the following:
    - a. General purpose:
      - 1) Temperature range: -20 degrees Celsius to +80 degrees Celsius.
    - b. Oil-resistant:
      - 1) Temperature range: -20 degrees Celsius to +60 degrees Celsius.
  2. Sunlight-resistant, weatherproof, and watertight.
  3. Manufactured from single strip steel, hot-dip galvanized on all 4 sides before conduit fabrication.
  4. Strip steel spiral wound resulting in an interior that is smooth and clean for easy wire pulling.
  5. Overall PVC jacket.
  6. With integral copper ground wire, built in the core, in conduit trade sizes 1/2 inch through 1-1/4 inch.
- D. PVC:
1. Extruded from virgin PVC compound:
    - a. Schedule 40 unless otherwise specified.
    - b. Schedule 80 extra-heavy wall where specified.
  2. Rated for 90 degrees Celsius conductors or cable.

3. Rated for use in direct sunlight.
- E. Inner duct:
1. HDPE and fabric inner duct are considered interchangeable.
  2. HDPE inner duct:
    - a. High-density polyethylene.
    - b. Corrugated.
    - c. Resin properties:
      - 1) Density, g/cm<sup>3</sup>: 0.941 to 0.955.
      - 2) Melt index g/10 minute Condition E: 0.05 to 0.5.
      - 3) Flexural modulus, MPa (pounds per square inch): 80,000 minimum.
      - 4) Tensile strength at yield (pounds per square inch): 3,000 minimum.
      - 5) Environmental stress crack resistance condition B, F<sub>10</sub>: 96 hours minimum.
      - 6) Brittleness temperature: -75 degrees Celsius.
    - d. Size: 1.25 inch.
    - e. Colors: Orange.
- F. Conduit bodies:
1. Material consistent with conduit type:
    - a. Malleable iron bodies and covers when used with Type GRC.
    - b. Cast aluminum bodies and covers when used with Type RAC.
    - c. PVC bodies and covers when used with Type PVC.
    - d. PVC-coated malleable iron bodies and covers when used with Type PCS.
    - e. PVC-coated copper-free cast aluminum bodies and covers when used with Type PCA.
    - f. Malleable iron or aluminum bodies with pressed steel or aluminum covers when used with Type EMT.
  2. Conduit bodies to conform to Form 8, Mark 9, or Mogul design:
    - a. Mogul design conforming to NEC requirements for bending space for large conductors for conduit trade sizes of 1 inch and larger with conductors #4 AWG and larger, or where required for wire-bending space.
  3. Gasketed covers attached to bodies with stainless steel screws secured to threaded holes in conduit body.

## 2.03 ACCESSORIES

- A. Connectors and fittings:
1. Manufactured with compatible materials to the corresponding conduit.
- B. Insulated throat metallic bushings:
1. Construction:
    - a. Malleable iron or zinc-plated steel when used with steel conduit.
    - b. Aluminum when used with aluminum conduit.
    - c. Positive metallic conduit end stop.
    - d. Integrally molded non-combustible phenolic-insulated surfaces rated at 150 degrees Celsius.

- e. Use fully insulated bushings on nonmetallic conduit system made of high-impact 150 degrees Celsius rated non-combustible thermosetting phenolic.
- C. Insulated grounding bushings:
- 1. Construction:
    - a. Malleable iron or steel, zinc-plated, with a positive metallic end stop.
    - b. Integrally molded non-combustible phenolic-insulated surfaces rated at 150 degrees Celsius.
    - c. Tin-plated copper grounding saddle for use with copper or aluminum conductors.
- D. Electrical unions (Erickson Couplings):
- 1. Construction:
    - a. Malleable iron for use with steel conduit.
    - b. Aluminum for use with aluminum conduit.
    - c. Concrete tight, 3-piece construction.
    - d. Rated for Class I Division 1 Group D in hazardous areas.
- E. SLT fittings:
- 1. Construction:
    - a. Malleable iron.
    - b. Furnished with locknut and sealing ring.
    - c. Liquidtight, rain-tight, oil-tight.
    - d. Insulated throat.
    - e. Furnish as straight, 45-degree elbows, and 90-degree elbows.
    - f. Designed to prevent sleeving:
      - 1) Verify complete bonding of the raceway jacket to the plastic gasket seal.
    - g. Equipped with grounding device to provide ground continuity irrespective of raceway core construction. Grounding device, if inserted into raceway and directly in contact with conductors, shall have rolled-over edges for sizes under 5 inches.
    - h. Where terminated into a threadless opening using a threaded hub fitting, a suitable moisture-resistant/oil-resistant synthetic rubber gasket shall be provided between the outside of the box or enclosure and the fitting shoulder. Gasket shall be adequately protected by and permanently bonded to a metallic retainer.
  - 2. Corrosion-resistant and outdoor SLT fittings:
    - a. Construction:
      - 1) PVC-coated liquidtight fittings with a bonded 0.040-inch thick PVC coating on the metal connector to form a seal around the SLT conduit.
      - 2) Insulated throat and an integral sealing ring.
- F. Hubs for threaded attachment of steel conduit to sheet metal enclosures:
- 1. Construction:
    - a. Insulated throat.

- b. PVC-coated when used in corrosive areas.
  - c. Bonding locknut.
  - d. Recessed neoprene O-ring to ensure watertight and dust-tight connector.
  - e. One half (1/2)-inch through 1-1/4-inch steel zinc electroplated.
  - f. One and one half (1-1/2)-inch through 6-inch malleable iron zinc plated.
  - g. Aluminum with aluminum conduit.
2. Usage:
    - a. All conduits in damp, wet, outdoor, and corrosive areas shall use threaded hubs for connections to sheet metal enclosures.
- G. PVC fittings:
1. Shall include the following:
    - a. Couplings.
    - b. Terminal adapters.
    - c. Female adapters.
    - d. Caps.
    - e. Reducer bushings.
    - f. Duct couplings.
    - g. End bells.
    - h. Expansion couplings.
    - i. Duct couplings: 5 degree.
    - j. C-Type pull fittings.
    - k. E-Type pull fittings.
    - l. LB-Type pull fittings.
    - m. LL-Type pull fittings.
    - n. LR-Type pull fittings.
    - o. T-Type pull fittings.
    - p. X-Type pull fittings.
    - q. Service entrance caps.
  2. Materials:
    - a. All devices shall be made of PVC, using the same materials as used for Type PVC conduit.
    - b. All metal hardware shall be stainless steel.
- H. Through wall and floor seals:
1. Materials:
    - a. Body: Casting of malleable or ductile iron with a hot-dip galvanized finish.
    - b. Grommet: Neoprene.
    - c. Pressure rings: PVC-coated steel.
    - d. Disc material: PVC-coated steel.
    - e. Aluminum when used with Type RAC.
- I. Expansion/deflection couplings:
1. Use to compensate for movement in any directions between 2 conduit ends where they connect.
  2. Shall allow movement of 3/4 inch from the normal in all directions.

3. Shall allow angular movement for a deflection of 30 degrees from normal in any direction.
  4. Constructed to maintain electrical continuity of the conduit system.
  5. Materials:
    - a. End couplings: Bronze or galvanized ductile iron.
    - b. Sleeve: Neoprene.
    - c. Bands: Stainless steel.
    - d. Bonding jumper: Tinned copper braid.
- J. Expansion couplings:
1. Shall allow for expansion and contraction of conduit:
    - a. Permitting 8-inch movement, 4 inches in either direction.
  2. Constructed to maintain electrical continuity of the conduit system.
  3. Materials:
    - a. Head: Malleable or ductile iron.
    - b. Sleeve: Steel.
    - c. Insulating bushing: Phenolic.
    - d. Finish: Hot-dip galvanized.
    - e. Aluminum when used with Type RAC.
- K. Inner duct couplings and fittings:
1. HDPE inner duct:
    - a. Couplings:
      - 1) Self-threading.
      - 2) Nonmetallic.
    - b. Fittings:
      - 1) Multi-access fitting:
        - a) [3][4]-hole.
        - b) Sized for conduit containing inner duct.
      - 2) Duct plugs:
        - a) Sized for inner duct diameter.
        - b) Install in both ends of all unused ducts.
      - 3) Split plugs:
        - a) Sized for inner duct and cable diameters.
        - b) Install at both ends of all utilized ducts.
  2. Fabric inner duct:
    - a. Termination bags:
      - 1) Inflation-type bags for sealing and securing around one or more textile inner ducts and cables within 2-inch outside diameter or larger conduit.
- L. Conduit markers:
1. As specified in Section 26\_05\_53.

## 2.04 SOURCE QUALITY CONTROL

- A. As specified in Section 26\_05\_00.

## PART 3 EXECUTION

### 3.01 INSTALLATION

- A. As specified in Section 26\_05\_00.
- B. General:
  - 1. Conduit routing:
    - a. The electrical drawings are diagrammatic in nature:
      - 1) Install conduit runs as specified with schematic representation indicated on the Drawings and as specified.
      - 2) Modify conduit runs to suit field conditions, as accepted by the Engineer:
        - a) Make changes in conduit locations that are consistent with the design intent but are dimensionally different, or routing to bypass obstructions.
        - b) Make changes in conduit routing due to the relocation of equipment.
      - 3) The electrical drawings do not indicate all required junction boxes and pull boxes:
        - a) Provide junction boxes and pull boxes to facilitate wire pulling as required:
          - (1) To meet cable manufacturer's pulling tension requirements.
          - (2) To limit total conduit bends between pull locations.
        - b) Install junction boxes and pull boxes at locations acceptable to the Engineer.
    - b. The Contractor is responsible for any deviations in general location, conduit size, routing, or changes to the conduit schedule without the express written approval or direction by the Engineer:
      - 1) The Engineer is the sole source in determining whether the change is constituted as a deviation:
      - 2) Perform any changes resulting in additional conduits, or extra work from such deviations.
      - 3) Incorporate any deviations on the Record Documents.
  - 2. Use only tools recommended by the conduit manufacturer for assembling the conduit system.
  - 3. Provide adequate clearances from high-temperature surfaces for all conduit runs. Provide minimum clearances as follows:
    - a. Clearance of 6 inches from surfaces 113 degrees Fahrenheit to 149 degrees Fahrenheit.
    - b. Clearance of 12 inches from surfaces greater than 149 degrees Fahrenheit.
    - c. Keep conduits at least 6 inches from the coverings on hot water and steam pipes, 18 inches from the coverings on flues and breechings, and 12 inches from fuel lines and gas lines.
    - d. Where it is necessary to route conduits close to high-temperature surfaces, provide a high-reflectance thermal barrier between the conduit and the surface.



4. Support conduit runs on water-bearing walls a minimum of 7/8-inch away from wall on an accepted preformed channel:
  - a. Do not run conduits within water-bearing walls unless otherwise indicated on the Drawings.
5. Do not install 1-inch or larger conduits in or through structural members unless approved by the Engineer.
6. Run conduits exposed to view parallel with or at right angles to structural members, walls, or lines of the building:
  - a. Install straight and true conduit runs with uniform and symmetrical elbows, offsets, and bends.
  - b. Make changes in direction with long radius bends or with conduit bodies.
7. Install conduits with total conduit bends between pull locations less than or equal to 270 degrees.
8. Route all exposed conduits to preserve headroom, access space and work space, and to prevent tripping hazards and clearance problems:
  - a. Install conduit runs so that runs do not interfere with proper and safe operation of equipment and do not block or interfere with ingress or egress, including equipment-removal hatches.
  - b. Route conduits to avoid drains or other gravity lines. Where conflicts occur, relocate the conduit as required.
9. When installing conduits through existing slabs or walls, make provisions for locating any possible conflicting items where the conduit is to penetrate. Use tone signal or X-ray methods to make certain that no penetrations will be made into the existing conduits, piping, cables, post-tensioning cables, etc.
10. Plug conduits brought into pull boxes, manholes, handholes, and other openings until used to prevent entrance of moisture.
11. Install conduits through wall and floor seals where indicated on the Drawings.
12. For existing and new 2-inch and larger conduit runs, snake conduits with a conduit cleaner equipped with a cylindrical mandrel of a diameter not less than 85 percent of nominal diameter of the conduit:
  - a. Remove and replace conduits through which mandrel will not pass.
13. Provide all sleeves and openings required for the passage of electrical raceways or cables even when these openings or sleeves are not specifically indicated on the Drawings.
14. Install complete conduit systems before conductors are installed.
15. Provide metallic conduits terminating in transformer, switchgear, motor control center, or other equipment conduit windows with grounding bushings and ground with a minimum No. 6 AWG ground wire.
16. Underground conduits:
  - a. Install underground conduits, including conduit runs below slabs-on-grade in concrete-reinforced duct bank construction:
    - 1) As specified in Section 26\_05\_44.
  - b. Make underground conduit size transitions at handholes and manholes.
  - c. Install spare conduits in underground duct banks towards top center of runs to allow for ease of installation of future cables as conduits enter underground manholes and handholes.

- d. Seal around conduit penetrations of below grade walls with a mechanical seal.
- C. Lighting and receptacle conduits:
- 1. Provide conduit runs for lighting and receptacle circuits, whether or not indicated on the Drawings:
  - 2. Install conduits in accordance with the requirements of this Section unless otherwise indicated.
  - 3. Minimum conduit size:
    - a. 3/4-inch for exposed conduits.
    - b. 1-inch for underground or in-slab conduits.
  - 4. Provide conduit materials for the installed location as specified in Section 26\_05\_00.
- D. Conduit usage:
- 1. Exposed conduits:
    - a. Rigid conduit:
      - 1) Install the rigid conduit type for each location as specified in Section 26\_05\_00.
      - 2) Minimum size: 3/4-inch.
    - b. Flexible conduit:
      - 1) Use flexible conduit for final connections between rigid conduit and motors, vibrating equipment, instruments, control equipment, or where required for equipment servicing:
        - a) Use Type SLT with rigid metallic conduit.
        - b) Use Type NFC with PVC conduit.
        - c) Use Type EFLX in Class I Division 1 locations.
        - d) Use Type FLX in finished areas.
      - 2) Minimum size: 3/4-inch:
        - a) 1/2 when required for connection to instruments.
      - 3) Maximum length:
        - a) Fixed equipment:

| Conduit Trade Size | Flexible Conduit Length<br>(inch) |
|--------------------|-----------------------------------|
| 3/4                | 18                                |
| 1                  | 18                                |
| 1-1/4              | 18                                |
| 1-1/2              | 18                                |
| 2                  | 36                                |
| 2-1/2              | 36                                |
| 3                  | 36                                |

| Conduit Trade Size | Flexible Conduit Length (inch) |
|--------------------|--------------------------------|
| 3-1/2              | 38                             |
| 4                  | 40                             |

- b) Removable instruments or hinged equipment:
  - (1) As required to allow complete removal or full movement without disconnecting or stressing the conduit.
- 2. Concrete-encased and embedded conduits:
  - a. Type PVC Schedule 40 and PVC-coated rigid metallic conduit as specified below:
    - 1) Use Type PCS in underground and embedded installation as follows:
      - a) Stub-up and risers to grade floor or equipment from nonmetallic conduits.
      - b) Entering and exiting underground or embedded conduit runs a minimum 12 inches above and below grade of finished floor.
      - c) For any and all bends where the total deflection is greater than 45 degrees.
    - b. Minimum size:
      - 1) 2-inch in duct banks unless otherwise indicated on the Drawings.
      - 2) 1-inch for in-slab conduits unless otherwise indicated on the Drawings.
- 3. Direct-buried and sand-bedded duct bank conduits:
  - a. Type PCS.
  - b. Minimum size: 1-inch.
- 4. Concrete capped, pea gravel-bedded duct bank conduits:
  - a. Type PVC40.
  - b. Minimum size: 1-inch.
- 5. PVC-coated rigid metallic conduit:
  - a. Use specifically manufactured or machined threading dies to manufacturer's specifications to accommodate the PVC jacket.
- 6. GRC:
  - a. Conduit shall be cut square and reamed before threading.
- 7. PVC:
  - a. Conduit terminations shall be via threaded adapters into threaded hubs on the junction boxes or conduit bodies.
  - b. Conduit terminations into boxes without threaded hubs shall utilize a threaded adapter and a flat neoprene washer on the outside of the box.
    - 1) Use a locknut on the inside of the box to tighten the adapter to the box.
  - c. Route conduit to afford it the maximum physical protection.
    - 1) If necessary, cover conduit to afford additional protection when it cannot be shielded by the structure or machinery frames.
      - a) Use Schedule 80 where exposed runs may be subject to physical damage.

- E. Conduit joints and bends:
1. General:
    - a. Where conduit is underground, under slabs on grade, exposed to the weather, or in NEMA Type 4 or NEMA Type 4X locations, make joints liquidtight.
    - b. Keep bends and offsets in conduit runs to an absolute minimum.
    - c. All bends shall be symmetrical.
    - d. The following conduit systems shall use large-radius sweep elbows:
      - 1) Underground conduits.
      - 2) Conduits containing medium-voltage cables.
      - 3) Conduits containing shielded cables.
      - 4) Conduits containing fiber optic cables.
    - e. Provide large-radius factory-made bends for 1-1/4-inch trade size or larger.
    - f. Make field bends with a radius of not less than the requirements found in the NEC:
      - 1) The minimum bending radius of the cable must be less than the radius of the conduit bend.
      - 2) Make all field bends with power bending equipment or manual benders specifically intended for the purpose:
        - a) Make bends so that the conduit is not damaged and the internal diameter is not effectively reduced.
        - b) For the serving utilities, make bends to meet their requirements.
    - g. Replace all deformed, flattened, or kinked conduit.
  2. Threaded conduit:
    - a. Cut threads on rigid metallic conduit with a standard conduit-cutting die that provides a 3/4-inch per foot taper and to a length such that all bare metal exposed by the threading operation is completely covered by the couplings or fittings used. In addition, cut the lengths of the thread such that all joints become secure and wrench-tight just preceding the point where the conduit ends would butt together in couplings or where conduit ends would butt into the ends or shoulders of other fittings.
    - b. Thoroughly ream conduit after threads have been cut to remove burrs.
    - c. Use bushings or conduit fittings at conduit terminations.
    - d. On exposed conduits, repair scratches and other defects with galvanizing repair stick, Enterprise Galvanizing "Galvabar," or CRC "Zinc It."
    - e. Coat conduit threads with an approved electrically conductive sealant and corrosion inhibitor that is not harmful to the conductor insulation:
      - 1) Apply to the male threads and tighten joints securely.
      - 2) Clean excess sealant from exposed threads after assembly.
    - f. Securely tighten all threaded connections.
    - g. Any exposed threaded surfaces must be cleaned and coated with a galvanizing solution so that all exposed surfaces have a galvanized protective coating.
  3. PVC:
    - a. Use approved solvent-weld cement specifically manufactured for the purpose. Spray-type cement is not allowed.

- b. Apply heat for bends so that conduit does not distort or discolor. Use a spring mandrel as required to ensure full inside diameter at all bends:
    - 1) Utilize a heater specifically for PVC conduit as recommended by the conduit manufacturer.
- F. Conduit sealing and drainage:
1. Conduit drainage and sealing other than required for hazardous and classified areas:
    - a. Provide sealing and drainage in vertical drops of long (in excess of 20 feet), exterior, above-grade conduit runs at the points at which the conduit enters buildings, switchgear, control panels, lighting panelboards, and other similar enclosures.
    - b. Provide seal fittings with drains in vertical drops directly above grade for exterior and above-grade conduit runs that are extended below grade.
    - c. Provide conduit seals with drains in areas of high humidity and rapidly changing temperatures:
      - 1) Where portions of an interior raceway pass through walls, ceilings, or floors that separate adjacent areas having widely different temperatures.
    - d. Provide conduit seals similar to O-Z/Gedney (Type CSM) on all conduits between corrosive and non-corrosive areas.
    - e. Seal one end only of all underground conduits at highest point with O-Z/Gedney sealing (non-hazardous) filling, or equal.
  2. Install seals with drains at any location along conduit runs where moisture may condense or accumulate. This requirement includes, but is not limited to, the following locations: control panels, junction boxes, pullboxes, or low points of the conduit.
- G. Conduit supports:
1. General:
    - a. Provide appropriate hangers, supports, fasteners, and seismic restraints to suit applications:
      - 1) As specified in Section 26\_05\_29.
      - 2) Provide support materials consistent with the type of conduit being installed as specified in Section 26\_05\_00.
    - b. Support conduit at the intervals required by the NEC.
    - c. Perforated strap and plumbers tape are not acceptable for conduit supports.
  2. Conduit on concrete or masonry:
    - a. Use 1-hole malleable iron straps with metallic or plastic expansion anchors and screws or support from preset inserts.
    - b. Use preset inserts in concrete when possible.
    - c. Use pipe spacers (clamp backs) in wet locations.
    - d. On plaster or stucco, use 1-hole malleable iron straps with toggle bolts.
  3. Conduit on metal decking:
    - a. Use 1-hole malleable iron straps with 1-inch long cadmium-plated Type A panhead sheet-metal screws. Fully or partially hammer-driven screws are not acceptable.

4. Suspended conduit:
    - a. Use malleable-iron factory-made split-hinged pipe rings with threaded suspension rods sized for the weight to be carried (minimum 3/8-inch diameter), Kindorf, or equal.
    - b. For grouped conduits, construct racks with threaded rods and tiered angle iron or preformed channel cross members. Clamp each conduit individually to a cross member. Where rods are more than 2-feet long, provide rigid sway bracing.
  5. Supports at structural steel members:
    - a. Use beam clamps.
    - b. Drilling or welding may be used only as specified or with approval of the Engineer.
  6. PVC-coated rigid metal systems:
    - a. Provide right-angle beam clamps and "U" bolts specially formed and sized to snugly fit the outside diameter of the coated conduit. Provide "U" bolts with PVC-encapsulated nuts that cover the exposed portions of the threads.
    - b. Securely fasten exposed conduits with Type 316 stainless steel clamps or straps.
- H. Expansion or expansion/deflection fittings:
1. General:
    - a. Align expansion coupling with the conduit run to prevent binding.
    - b. Follow manufacturer's instructions to set the piston opening.
    - c. Install expansion fittings across concrete expansion joints and at other locations where necessary to compensate for thermal or mechanical expansion and contraction.
    - d. Furnish fittings of the same material as the conduit system.
  2. For metallic conduit, provide expansion or expansion/deflection couplings, as appropriate, where:
    - a. Install expansion fittings a minimum of every 200 feet in straight conduit runs.
  3. For PVC, provide expansion or expansion/deflection couplings, as appropriate, where length change due to temperature variation exceeds 2 inches:
    - a. Rigidly fix the outer barrel of the expansion coupling so it cannot move.
    - b. Mount the conduit connected to the piston loosely enough to allow the conduit to move as the temperature changes.
- I. Empty conduits:
1. Provide a polyethylene rope rated at 250 pounds tensile strength in each empty conduit more than 10 feet in length.
  2. Seal ends of all conduits with approved, manufactured conduit seals, caps, or plugs immediately after installation:
    - a. Keep ends sealed until immediately before pulling conductors.

- J. Miscellaneous:
1. Seal roof penetrations for raceways and other items that penetrate the roof in accordance with roofing manufacturer's instructions and as indicated on the Drawings.
  2. Provide electrical unions at all points of union between ends of rigid conduit systems that cannot otherwise be coupled:
    - a. Running threads and threadless couplings are not allowed.
  3. Replace any conduits installed that the Engineer determines do not meet the requirements of this Specification.
  4. Provide conduit housekeeping curb around all embedded or below-grade conduits exiting or entering the slab, per the Typical Details.

### **3.02 FIELD QUALITY CONTROL**

- A. As specified in Section 26\_05\_00.

### **3.03 PROTECTION**

- A. As specified in Section 26\_05\_00.

## **PART 4 MEASUREMENT**

### **4.01 METHOD OF MEASUREMENT**

- A. No separate measurement shall be made for work under this Section.

## **PART 5 PAYMENT**

### **5.01 METHOD OF PAYMENT**

- A. No separate payment will be made for work under this Section. The cost of the work described in this Section shall be included in the applicable lump sum bid item.

END OF SECTION

## SECTION 26\_05\_34

### BOXES

#### PART 1 GENERAL

##### 1.01 SUMMARY

- A. Section includes:
  - 1. Device boxes.
  - 2. Raceway system boxes.
- B. Related sections:
  - 1. Section 26\_05\_00 - Common Work Results for Electrical.

##### 1.02 REFERENCES

- A. As specified in Section 26\_05\_00.
- B. ASTM International (ASTM):
  - 1. A47 - Standard Specification for Ferritic Malleable Iron Castings.
  - 2. D149 - Standard Test Method for Dielectric Breakdown Voltage and Dielectric Strength of Solid Electrical Insulating Materials at Commercial Power Frequencies.
  - 3. D495 - Standard Test Method for High-Voltage, Low-Current, Dry Arc Resistance of Solid Electrical Insulation.
  - 4. D570 - Standard Test Method for Water Absorption of Plastics.
  - 5. D648 - Standard Test Method for Deflection Temperature of Plastics Under Flexural Load in the Edgewise Position.
  - 6. D790 - Standard Test Methods for Flexural Properties of Unreinforced and Reinforced Plastics and Electrical Insulating Materials.
  - 7. D792 - Standard Test Methods for Density and Specific Gravity (Relative Density) of Plastics by Displacement.
- C. Joint Industry Conference (JIC).
- D. Underwriters Laboratories, Inc. (UL):
  - 1. 94 - Standard for Tests for Flammability of Plastic Materials for Parts in Devices and Appliances.

##### 1.03 DEFINITIONS

- A. As specified in Section 26\_05\_00.



- B. Specific definitions:
  - 1. Arcing parts: Circuit breakers, motor controllers, switches, fuses, or any device intended to interrupt current during its operation.
  - 2. Raceway system boxes: Boxes that are used for wire and cable pullboxes, conduit junction boxes, or terminal boxes.

#### 1.04 SYSTEM DESCRIPTION

- A. Provide outlet boxes for devices such as switches, receptacles, telephone and computer jacks, security systems, junction, and pullboxes for use in the raceway systems, etc.
- B. Provide boxes as indicated on the Drawings or as needed to complete the raceway installation.

#### 1.05 SUBMITTALS

- A. Furnish submittals as specified in Section 26\_05\_00.
- B. Product data:
  - 1. Manufacturer.
  - 2. Materials.
  - 3. Dimensions:
    - a. Height.
    - b. Width.
    - c. Depth.
    - d. Weight.
    - e. NEMA rating.
  - 4. Conduit entry locations.
  - 5. Catalog cut sheets.
  - 6. Installation instructions.
- C. Shop drawings:
  - 1. Include identification and sizes of pull boxes.

#### 1.06 QUALITY ASSURANCE

- A. As specified in Section 26\_05\_00.
- B. Regulatory requirements:
  - 1. Outlet boxes shall comply with all applicable standards of:
    - a. JIC.
    - b. NEC.
    - c. NEMA.
    - d. UL.

## **1.07 DELIVERY, STORAGE, AND HANDLING**

A. As specified in Section 26\_05\_00.

## **1.08 PROJECT OR SITE CONDITIONS**

A. As specified in Section 26\_05\_00.

## **1.09 SEQUENCING**

A. As specified in Section 26\_05\_00.

## **1.10 WARRANTY**

A. As specified in Section 26\_05\_00.

## **1.11 SYSTEM START-UP**

A. As specified in Section 26\_05\_00.

## **PART 2 PRODUCTS**

### **2.01 MANUFACTURERS**

- A. One of the following or equal:
1. Pressed steel boxes:
    - a. Steel City.
    - b. Appleton.
    - c. Crouse - Hinds.
    - d. Thomas & Betts.
  2. Plastic and/or fiberglass boxes:
    - a. Hoffman.
    - b. Carlon.
    - c. Stahlin.
  3. Plastic coated boxes:
    - a. Rob Roy.
    - b. OCAL.
  4. Cast device boxes:
    - a. Appleton.
    - b. Crouse - Hinds.
    - c. OZ/Gedney.
  5. Floor outlet boxes with 1-inch conduit knockouts:
    - a. Steel City, 640 Series.
    - b. Hubbell type B25 with S2530 coverplate.
  6. Floor outlet boxes in open areas:
    - a. Hubbell.

7. Formed steel enclosures:
  - a. Hoffman.
  - b. Thomas and Betts.
  - c. Stahlin.
  - d. Rittal.
8. Stainless steel enclosures:
  - a. Hoffman.
  - b. Stahlin.
  - c. Rittal.
9. Pressed steel boxes and concrete boxes:
  - a. Appleton.
  - b. Steel City.
  - c. Cooper/Crouse Hinds.
  - d. OZ Gedney.

## 2.02 MANUFACTURED UNITS

- A. Pressed steel boxes:
  1. One-piece galvanized pressed steel.
  2. Knockout type boxes.
  3. Minimum size 4-inch square by 2-1/8-inch deep.
- B. Concrete boxes:
  1. For outlets and pull boxes in concrete construction.
  2. Pressed steel or cast construction, concrete tight.
  3. Knockout sizes range from 1/2 inch to 1 inch.
  4. Depth as needed.
  5. Types:
    - a. Four-inch octagon.
    - b. Four-inch octagon ceiling boxes with hanging bars.
    - c. Gangable masonry boxes:
      - 1) 3-1/2-inch deep, 3-3/4-inch high, length as required:
        - a) 2-1/2-inch deep boxes may be used where wall thickness precludes the use of the deeper boxes.
      - 2) With partitions as needed.
- C. Cast device boxes:
  1. Construction:
    - a. With internal green ground screw.
    - b. Furnished with a suitable gasketed cover.
    - c. With integral cast mounting lugs when surface mounted.
    - d. Conduit sizes range from 3/4 inch to 1 inch.
    - e. Tapered threaded hubs with integral bushing.
  2. Aluminum (copper free) boxes:
    - a. High strength copper free 4/10 of 1 percent maximum alloy for use with aluminum rigid conduit.

3. Malleable iron boxes:
  - a. Conforming to ASTM A47 Grade 32510.
  
- D. Formed steel enclosures:
  1. Steel:
    - a. NEMA Type 12.
    - b. Fabricated from 14-gauge steel, minimum.
    - c. All seams continuously welded ground smooth.
    - d. Door:
      - 1) Rolled lip around 3 sides.
      - 2) Attached to enclosure by means of a continuous stainless steel hinge and pin.
    - e. Neoprene door gasket to provide a watertight, dusttight, oiltight seal:
      - 1) Attached with an adhesive.
      - 2) Retained by a retaining strip.
    - f. Fabricate all external removable hardware for clamping the door to the enclosure body from zinc-plated heavy gauge steel:
      - 1) With a hasp and staple for padlocking.
    - g. Provide large enclosures with door and body stiffeners for extra rigidity.
    - h. No holes or knockouts.
    - i. Finish:
      - 1) ANSI-61 gray electrostatically applied polyester powder inside and out over cleaned and primed surfaces.
      - 2) White electrostatically applied polyester powder mounting plate.
    - j. Heavy gauge steel external mounting brackets when surface mounted.
  2. Stainless steel:
    - a. NEMA Type 4X:
      - 1) Boxes in locations subject to flooding or temporary submersion:
        - a) NEMA Type 6.
    - b. Fabricated from 14-gauge Type 316 stainless steel.
    - c. All seams continuously welded.
    - d. Door:
      - 1) Rolled lip around 3 sides.
      - 2) Attached to enclosure by means of a continuous stainless steel hinge and pin.
    - e. Neoprene door gasket to provide a watertight seal:
      - 1) Attached with an adhesive.
      - 2) Retained by a retaining strip.
    - f. Fabricate all external removable hardware for clamping the door to the enclosure body from heavy gauge stainless steel:
      - 1) With a hasp and staple for padlocking.
    - g. Provide large enclosures with door and body stiffeners for extra rigidity.
    - h. No holes or knockouts.
    - i. Finish:
      - 1) Brushed.
    - j. Stainless steel external mounting brackets when surface mounted.

- E. Cast iron junction boxes:
  - 1. NEMA Type 4.
  - 2. Recessed cover boxes.
  - 3. Suitable for use outdoors where subject to rain, dripping, or splashing water.
  - 4. Designed for flush mounting in walls or floors:
    - a. Can be surface mounted using mounting lugs.
  - 5. Construction:
    - a. Cast iron box.
    - b. Covers:
      - 1) Checkered plate covers suitable for foot traffic.
      - 2) When used in areas subject to vehicular traffic H-20 loading.
    - c. Hot dip galvanized.
    - d. Neoprene gasket.
    - e. Stainless steel screw covers.

## 2.03 ACCESSORIES

- A. Fasteners:
  - 1. Electroplated or stainless steel in boxes with wiring devices.
  - 2. Screws, nuts, bolts, and other threaded fasteners:
    - a. Stainless steel.
- B. Provide breather and drain fittings where appropriate.
- C. Internal panels:
  - 1. Provide internal panels where required for mounting of terminal strips or other equipment.
  - 2. With plated steel shoulder studs.
  - 3. Steel with white polyester powder finish.

## PART 3 EXECUTION

### 3.01 INSTALLATION

- A. As specified in Section 26\_05\_00.
- B. General:
  - 1. Provide materials and construction suitable for environmental conditions at the location of the box as specified in Section 26\_05\_00.
  - 2. Provide outlet box materials to match the conduit system:
    - a. EMT - Pressed metal boxes.
    - b. GRC - Cast ferrous boxes.
    - c. RAC - Aluminum (copper free) boxes.
    - d. PCS - PVC coated cast ferrous boxes.
    - e. PVC - PVC boxes.
    - f. PCA - PVC coated aluminum boxes.

3. Solid type gang boxes:
    - a. For more than 2 devices.
    - b. For barriered outlets.
  4. Support all wall mounted NEMA Type 4 or NEMA Type 4X boxes to maintain a minimum of 7/8-inch free air space between the back of the enclosure and the wall:
    - a. Use machined spacers to maintain air space; built-up washers are not acceptable.
    - b. Use stainless steel or nylon materials for spacers.
  5. Use cast malleable iron boxes when box must support other devices.
  6. Boxes serving luminaires or devices:
    - a. Use as pull boxes wherever possible.
  7. Fit all cast boxes and pressed steel boxes for flush mounting in concrete with cast, malleable box covers and gaskets.
  8. In terminal boxes, furnish terminals as indicated on the Drawings, with a minimum of 50 percent spare terminals:
    - a. Furnish wireways for discrete and analog/DC wiring.
    - b. Separate analog wiring from 120 V discrete or power wiring.
  9. Size boxes in accordance with NEC requirements and to provide sufficient room for the future components and cables indicated on the Drawings.
  10. For fire-rated construction, provide materials and installation for use in accordance with the listing requirements of the classified construction.
- C. Outlet boxes:
1. Locate outlet boxes as indicated on the Drawings:
    - a. Adjust locations so as not to conflict with structural requirements or other trades.
  2. Use deep threaded-hub malleable iron or aluminum boxes:
    - a. In hazardous areas.
    - b. Where exposed to the weather.
    - c. In unheated areas.
    - d. Where subject to mechanical damage:
      - 1) Defined as exposed boxes less than 10 feet above the floor.
    - e. To act as a pull box for conductors in a conduit system.
    - f. Accommodate wiring devices.
  3. Use deep threaded-hub plastic coated malleable iron boxes in corrosive and NEMA Type 4X area and when the conduit system is PVC coated steel.
  4. Outlet boxes may be used as junction boxes wherever possible.
- D. Pull boxes and junction boxes:
1. Size pull boxes in accordance with NEC requirements and to provide sufficient room for any future conduits and cables as indicated on the Drawings.
  2. Install pull boxes such that access to them is not restricted.

- E. For boxes not indicated:
  - 1. Provide types and mountings as required to suit the equipment and that will be consistent with the conduit system and environmental conditions as indicated in Section 26\_05\_00.
  - 2. Outlet, switch, and junction boxes for flush-mounting in general purpose locations:
    - a. One-piece, galvanized, pressed steel.
  - 3. Ceiling boxes for flush mounting in concrete:
    - a. Deep, galvanized, pressed steel.
  - 4. Outlet, switch, and junction boxes where surface mounted in exposed locations:
    - a. Cast ferrous boxes with mounting lugs, zinc or cadmium plating finish.
  - 5. Outlet, control station, and junction boxes for installation in corrosive locations:
    - a. Fiberglass reinforced polyester, stainless steel, or plastic coated steel to match the conduit system.
    - b. Furnished with mounting lugs.
  - 6. Fire rated construction: Use materials and methods to comply with the listing requirements for the classified construction.

### **3.02 FIELD QUALITY CONTROL**

- A. As specified in Section 26\_05\_00.

### **3.03 CLEANING**

- A. As specified in Section 26\_05\_00.

### **3.04 PROTECTION**

- A. As specified in Section 26\_05\_00.

## **PART 4 MEASUREMENT**

### **4.01 METHOD OF MEASUREMENT**

- A. No separate measurement shall be made for work under this Section.

## **PART 5 PAYMENT**

### **5.01 METHOD OF PAYMENT**

- A. No separate payment will be made for work under this Section. The cost of the work described in this Section shall be included in the applicable lump sum bid item.

END OF SECTION

## SECTION 26\_05\_44

### DUCT BANKS

#### PART 1 GENERAL

##### 1.01 SUMMARY

- A. Section includes:
  - 1. Electrical underground duct banks.
  - 2. Duct bank installation requirements.
- B. Related sections:
  - 1. Section 26\_05\_00 - Common Work Results for Electrical.
  - 2. Section 26\_05\_33 - Conduits.

##### 1.02 REFERENCES

- A. As specified in Section 26\_05\_00.

##### 1.03 DEFINITIONS

- A. As specified in Section 26\_05\_00.

##### 1.04 SYSTEM DESCRIPTION

- A. Provide trenching, forming, rebar, spacers, conduit, concrete, backfill, and compaction necessary for the complete installation of the duct banks.
- B. Provide reinforced concrete duct banks for all conduits installed below grade, on the site, below structures, or in contact with the earth, unless otherwise indicated on the Drawings.

##### 1.05 SUBMITTALS

- A. Furnish submittals as specified in Section 26\_05\_00.
- B. Product data:
  - 1. PVC conduit spacers.
  - 2. Detectable underground marking tape.
  - 3. Pull line.
- C. Shop drawings:
  - 1. Submit site plan drawings of duct banks including underground profiles indicating all underground utilities.



## **1.06 QUALITY ASSURANCE**

- A. As specified in Section 26\_05\_00.

## **1.07 DELIVERY, STORAGE, AND HANDLING**

- A. As specified in Section 26\_05\_00.

## **1.08 PROJECT OR SITE CONDITIONS**

- A. As specified in Section 26\_05\_00.
- B. Field conditions and related requirements:
  - 1. Underground water table may be near or above the location of new duct banks.
  - 2. Include cost for necessary dewatering, and cleaning equipment to perform work in underground duct banks, pull boxes and manholes, before installation.

## **1.09 WARRANTY**

- A. As specified in Section 26\_05\_00.

## **1.10 SYSTEM START-UP**

- A. As specified in Section 26\_05\_00.

# **PART 2 PRODUCTS**

## **2.01 MANUFACTURERS**

- A. Conduit spacers:
  - 1. One of the following or equal:
    - a. Carlon Snap-Loc.
    - b. Cantex.
    - c. Osburn Associates, Inc.
- B. Detectable underground marking tape:
  - 1. One of the following or equal:
    - a. Blackburn Manufacturing Company.
    - b. Pro-Line Safety Products.
    - c. Panduit.
- C. Pull line:
  - 1. One of the following or equal:
    - a. Arnco.
    - b. Greenlee.
    - c. Osburn Associates, Inc.

## 2.02 MATERIALS

- A. Provide conduit as specified in Section 26\_05\_33:
  - 1. Use duct suitable for use with 90-degree Celsius rated conductors.
- B. Provide reinforcing steel as specified in Section 03\_20\_00:
  - 1. Provide minimum Number 4 reinforcing steel.

## 2.03 MANUFACTURED UNITS

- A. Conduit spacers:
  - 1. Provide conduit spacers recommended by the conduit manufacturer or specified above.
  - 2. Saddle type.
  - 3. Non-metallic, non-corrosive, non-conductive.
  - 4. Interlocking type:
    - a. Vertical interlocking.
    - b. Horizontal interlocking.
  - 5. Suitable for concrete encasement.
  - 6. Molded-in rebar holder.
  - 7. Accommodates 2-inch through 6-inch conduit sizes.
  - 8. Relieves the conduit from both horizontal and vertical stresses.
- B. Pull line:
  - 1. Minimum 1/4-inch wide, flat design.
  - 2. Polyester.
  - 3. Minimum pulling strength 1,200 pounds.
  - 4. Sequential footage markings.
- C. Detectable marking tape:
  - 1. Provide a detectable tape, locatable by a cable or metal detector from above the undisturbed grade.
  - 2. Aluminum core laminated between polyethylene film.
  - 3. Six-inch wide red tape imprinted with black lettering "CAUTION - BURIED ELECTRIC UTILITIES."

## 2.04 MIXES

- A. Concrete mix requirements as specified.
- B. Provide a red-oxide conduit encasement coloring agent as specified.

## PART 3 EXECUTION

### 3.01 INSTALLATION

- A. As specified in Section 26\_05\_00.

- B. Duct banks:
1. Install duct banks encased in concrete at least 24 inches below finish grade, unless otherwise indicated on the Drawings.
  2. Damage minimization:
    - a. Conduit should not be left exposed in an open trench longer than is necessary.
    - b. Protect all underground duct banks against damage during pouring of concrete or backfilling.
  3. All plastic conduit fittings to be joined should be exposed to the same temperature conditions for a reasonable length of time before assembly.
  4. Provide No. 4/0 American Wire Gauge bare copper ground wire the entire length of duct bank and bond to the grounding system as indicated on the Drawings and every 20 feet to steel reinforcing bar.
  5. Install underground ducts to be self-draining:
    - a. Slope duct banks away from buildings to manholes.
    - b. Slope duct banks uniformly from manholes to manholes or both ways from high points between manholes.
    - c. Slope a minimum of 1/4 inch per 10 feet.
  6. Where new duct banks join to existing manholes make the proper fittings and fabricate the concrete envelopes to ensure smooth durable transitions, as indicated on the Drawings.
  7. Install pull line in spare conduits:
    - a. Provide adequate pull line at both ends of conduits to facilitate conductor pulling.
    - b. Cap above ground spare conduit risers at each end with screw-on conduit caps.
- C. Trenching:
1. Perform trenching as specified.
  2. Trench must be uniformly graded with the bottom, rock free and covered with select material.
  3. Whenever possible, use the walls of the trench as forms for concrete encasement:
    - a. Forms are required where the soil is not self-supporting.
  4. Avoid damaging existing ducts, conduits, cables, and other utilities.
- D. Duct spacing:
1. Separate conduits with manufactured plastic spacers using a minimum space between the outside surfaces of adjacent conduits of 2 inches, unless otherwise indicated on the Drawings:
    - a. Separate medium voltage ducts a minimum of 7.5 inches on center.

2. Install spacers to maintain uniform spacing of duct assembly a minimum of 4 inches above the bottom of the trench during concrete pour. Install spacers on 8-foot maximum intervals:
    - a. Due to some distortion of conduit from heat, and other means, it may be necessary to install extra spacers within the duct bank:
      - 1) Install the intermediate set of spacers within normal required spacing to maintain the proper horizontal clearance:
        - a) Clearance is required to allow the proper amount of concrete to infiltrate vertically among the duct to ensure proper protection.
  3. Spacers shall not be located at the center of a bend:
    - a. Locate spacer in the tangent, free of the coupling on fabricated bends.
    - b. Locate spacers midway between the tangent and the center bend on trench formed sweeps.
- E. Terminating:
1. Use bell ends in duct at entrances into cable vaults.
  2. Make conduit entrances into cable vaults tangential to walls of cable vault.
  3. Form trapezoidal transitions between duct bank and cable vaults as needed in order to ensure adequate cable bending radius for the duct bank-to-vault transition.
  4. New manhole or handhole applications, provide a single opening or “window” per duct bank, sized to accommodate the duct bank envelope.
- F. Concrete:
1. Install concrete as specified.
  2. Provide nonferrous tie wires to prevent displacement of the conduits during pouring of concrete:
    - a. Tie wire shall not act as a substitute for spacers.
  3. Install minimum 3-inch cover around conduit and rebar.
  4. Consolidation of encasement concrete around duct banks shall be by hand puddling, with no mechanical vibration.
  5. Conduit is subject to temperature rise. As concrete cures, allow the free end to expand by pouring the concrete from the center of the run or from one tie in point.
- G. Marking tape:
1. Install a detectable marking tape 12 inches above the duct bank the entire length of the duct bank.
- H. For conduit installations beneath building slabs:
1. Install steel reinforced concrete duct banks under all building slabs as indicated on the Drawings:
    - a. Concrete for encasement under building slabs need not be colored red.
    - b. For duct banks crossing under building footers or foundations, install the top of the duct bank a minimum of 6 inches below the footer.
    - c. Where duct banks enter through building walls, foundation walls, stem walls, etc. make connections as indicated on the Drawings.

- d. Where duct banks terminate with conduit risers entering building walls, install an expansion/deflection fitting or a flat-wise elbow (elbow parallel to building wall) in order to accommodate differential movement between the conduits and structure.

I. Restore all surfaces to their original condition, unless otherwise specified.

### **3.02 FIELD QUALITY CONTROL**

A. As specified in Section 26\_05\_00.

### **3.03 CLEANING**

A. Clean conduits of dirt and debris by use of an appropriately sized steel mandrel no less than 1/2 inch smaller than the inside diameter of the conduit.

### **3.04 PROTECTION**

A. As specified in Section 26\_05\_00.

B. Provide shoring and pumping to protect the excavation and safety of workers.

C. Protect excavations with barricades as required by applicable safety regulations.

## **PART 4 MEASUREMENT**

### **4.01 METHOD OF MEASUREMENT**

A. No separate measurement shall be made for work under this Section.

## **PART 5 PAYMENT**

### **5.01 METHOD OF PAYMENT**

A. No separate payment will be made for work under this Section. The cost of the work described in this Section shall be included in the applicable lump sum bid item.

END OF SECTION

## SECTION 26\_05\_53

### IDENTIFICATION FOR ELECTRICAL SYSTEMS

#### PART 1 GENERAL

##### 1.01 SUMMARY

- A. Section includes:
  - 1. Identification of electrical equipment, devices and components.
  - 2. Material, manufacturing and installation requirements for identification devices.
  
- B. Related sections:
  - 1. Section 26\_05\_00 - Common Work Results for Electrical.
  - 2. Section 26\_05\_33 - Conduits.
  - 3. Section 26\_06\_01 - Conduit Schedule.

##### 1.02 REFERENCES

- A. As specified in Section 26\_05\_00.
  
- B. Occupational Safety and Health Administration (OSHA).

##### 1.03 DEFINITIONS

- A. As specified in Section 26\_05\_00.

##### 1.04 SYSTEM DESCRIPTION

- A. Nameplates:
  - 1. Provide a nameplate for each piece of electrical equipment and devices, control panel and control panel components.
  - 2. Provide all nameplates of identical style, color, and material throughout the facility.
  - 3. Device nameplates information:
    - a. Designations as indicated on the Drawings and identified on the Process and Instrumentation Drawings.
  
- B. Wire numbers:
  - 1. Coordinate the wire numbering system with all vendors of equipment so that every field wire has a unique number associated with it for the entire system:
    - a. Wire numbers shall correspond to the wire numbers on the control drawings or the panel and circuit numbers for receptacles and lighting.
    - b. Wire numbers shall correspond to the terminal block number to which they are attached in the control panel.

- c. Internal panel wires on a common terminal shall have the same wire number.
- d. Multi-conductor cables shall be assigned a cable number that shall be attached to the cable at intermediate pull boxes and stub-up locations beneath freestanding equipment. All multi-conductor and instrumentation cables shall be identified at pull points as described above:
  - 1) Label armored multi-conductor cable using the conduit number as indicated on the Drawings, following the requirements for conduit markers in Section 26\_05\_33.
- 2. Provide the following wiring numbering schemes throughout the project for field wires between process control module, (PCM), vendor control panels, (VCP), motor control centers, (MCC), field starters, field instruments, etc.

(ORIGIN LOC.)-(ORIGIN TERM.)/(DEST. LOC.)-(DEST. TERM.)

OR

(ORIGIN LOC.)-(ORIGIN TERM.)  
(DEST. LOC.)-(DEST. TERM.)

Where:

- ORIGIN LOC. = Designation for originating panel or device
- ORIGIN TERM. = Terminal designation at originating panel or device
- DEST. LOC. = Designation for destination panel or device
- DEST. TERM. = Terminal designation at destination panel or device or PLC

I/O address at destination panel:

- a. Identify equipment and field instruments as the origin.
- b. PCMs are always identified as the destination.
- c. Location is the panel designation for VCP, LCP, or PCM. For connections to MCCs, location is the specific starter tag and loop number. Location is the tag and loop number for motor starters, field instruments and equipment. Any hyphen in the panel designation or tag and loop number shall be omitted.
- d. Terminal designation is the actual number on the terminal block where the conductor terminates at field devices and vendor control panels. For multi-conductor cables, all terminal numbers shall be shown, separated by commas.
- e. Terminal designations at motor leads shall be the motor manufacturer's standard terminal designation (e.g. T1, T2, T3, etc.).

- f. Terminal designations at PCMs where the field conductor connects to field terminal blocks for a PLC input or output shall be the PLC address (Note: the following PLC I/O numbering scheme is typical for Allen-Bradley, the numbering scheme should be modified to match that of the actual PLC manufacturer used for the project):
- 1) Discrete Point: W:X:Y/Z  
Analog Point: W:X:Y.Z  
Where:  
W = I for input, O for output  
X = PLC number (1, 2, 3...)  
Y = Slot number (01, 02, 03...)  
Z = Terminal number (00, 01, 02...) for a discrete point or a word number for an analog point (1, 2, 3...)
- g. Terminal designations at PCMs where the conductor does not connect to a PLC I/O point shall be the terminal number with a "C" prefix (e.g. C0010). For common power after a fuse or neutrals after a switch, the subsequent points shall have and capital letter suffix starting with "A" (e.g. C0010A).
3. **Case 1:** Vendor control panel (VCP) to process control module (PCM):  
Field wire number/label: A-B/C-D  
A = Vendor control panel number without hyphen (VCP#)  
B = Terminal number within VCP (manufacturer's or vendor's standard terminal number)  
C = Process control module number without hyphen (PCM#)  
D = Either the PLC address if the field terminal is connected directly to a PLC input or output point or the terminal number with a "C" prefix if not connected directly to a PLC I/O point (C0010)
- Examples: VCP#-10/PCM#-I:1:01/01  
VCP#-10/PCM#-O:1:10/07  
VCP#-10/PCM#-C0100
4. **Case 2:** Field instrument to process control module (PCM):  
Field wire number/label: E-F/C-D  
C = Process control module number without hyphen (PCM#)  
D = Either the PLC address if the field terminal is connected directly to a PLC input or output point or the terminal number with a "C" prefix if not connected directly to a PLC I/O point (C0010)  
E = Field mounted instrument tag and loop numbers without hyphen (EDV#)  
F = Manufacturer's standard terminal number within instrument. Use both terminal numbers for analog points separated by a comma
- Examples: TIT#-2,3/PCM#-I:1:01.1  
TSH#-1/PCM#-I:2:01/00



5. **Case 3:** Motor control center (MCC) to process control module (PCM):  
Field wire number/label: G-B/C-D  
B = Terminal number within Motor Control Center (manufacturer's or vendor's standard terminal number)  
C = Process control module without hyphen (PCM#)  
D = Either the PLC address if the field terminal is connected directly to a PLC input or output point or the terminal number with a "C" prefix if not connected directly to a PLC I/O point (C0010)  
G = Actual starter designation in the motor control center without hyphen (MMS#)

Examples:     MMS#-10/PCM#-I:1:01/01  
                  MMS#-10/PCM#-O:1:10/07  
                  MMS#-10/PCM#-C0100

6. **Case 4:** Motor control center (MCC) to vendor control panel (VCP):  
Field wire number/label: G-B/A-B  
A = Vendor control panel number without hyphen (VCP#)  
B = Terminal number within motor control center or vendor control panel (manufacturer's or vendors standard terminal number)  
G = Actual starter designation in the motor control center without hyphen (MMS#)

Example:             MMS#-X2/VCP#-10

7. **Case 5:** Motor leads to a motor control center (MCC):  
Field wire number/label: H-I/G-B  
B = Terminal number within motor control center (manufacturer's standard terminal number)  
G = Actual starter designation in the motor control center without hyphen (MMS#)  
H = Equipment tag and loop number without hyphen (PMP#)  
I = Motor manufacturer's standard motor lead identification (e.g. T1, T2, T3, etc.)

Example:             PMP-#-T3/MMS#-T3

8. **Case 6:** Remote or separately mounted starter or variable frequency drive (VFD) to process control module (PCM):  
Field wire number/label: J-B/C-D  
B = Terminal number within starter or variable frequency drive (manufacturer's standard terminal number)  
C = Process control module number without hyphen (VCP#)  
D = Either the PLC address if the field terminal is connected directly to a PLC input or output point or the terminal number with a "C" prefix if not connected directly to a PLC I/O point (C0010)

J = Starter or variable frequency drive tag and loop number without hyphen (MMS#)

Examples: MMS#-10/PCM#-I:1:01/01  
MMS#-10/PCM#-O:2:10/07  
MMS#-10/PCM#-C0010

9. **Case 7:** Field bus trunk segment:

Field cable number/label: C/K-L/M; C/K-L/H; C/K-L/J

C = Process control module without hyphen (PCM#).

K = Field bus cable type.

L = Field bus segment number.

M = Field Bus field network component without hyphen (PTB1) or

H = Equipment tag and loop number without hyphen (EMV#) or

J = Starter or variable frequency drive tag and loop number without hyphen (VFD60.0112)

Examples: PCM#/PA-1A/PTB1PTB1/PA-1B/PTB2  
PCM#/DN-1A/VFD#  
PCM#/DP-2A/ EMV#

10. **Case 8:** Field bus spur (drop):

Field cable number/label: E/K-L/M

E = Field mounted instrument tag and loop numbers without hyphen (FIT#)

K = Field bus cable type.

L = Field bus segment number

M = Field bus field network component without hyphen (PTB1), identify ports on the device.

Examples: FIT#/PA-1C/PTB1-1  
FIT#/PA-1D/PTB1-2

11. Identify all spare conductors as required for other field wires with an "S" prefix:

Example: S MMS#-10/PCM#-C011

## 1.05 SUBMITTALS

A. Furnish submittals as specified in Section 26\_05\_00.

B. Product data:

1. Nameplates:

a. Color.

b. Size:

1) Outside dimensions.

2) Lettering.

- c. Material.
    - d. Mounting means.
  - 2. Nameplate schedule:
    - a. Show exact wording for each nameplate.
    - b. Include nameplate and letter sizes.
  - 3. Wire numbers:
    - a. Manufacturer's catalog data for wire labels and label printer.
- C. Record documents:
  - 1. Update the conduit schedule to reflect the exact quantity of wire numbers including spares and destination points for all wires.

## **1.06 DELIVERY, STORAGE, AND HANDLING**

- A. As specified in Section 26\_05\_00.

## **1.07 WARRANTY**

- A. As specified in Section 26\_05\_00.

## **1.08 SYSTEM START-UP**

- A. As specified in Section 26\_05\_00.

## **PART 2 PRODUCTS**

### **2.01 MANUFACTURERS**

- A. Nameplates and signs:
  - 1. One of the following or equal:
    - a. Brady.
    - b. Seton.
- B. Conductor and cable markers:
  - 1. Heat-shrinkable tubing:
    - a. One of the following or equal:
      - 1) Raychem.
      - 2) Brady.
      - 3) Thomas & Betts.
      - 4) Kroy.
  - 2. Non heat-shrinkable tubing:
    - a. One of the following or equal:
      - 1) Brady.
      - 2) Seton.
  - 3. Marker printer:
    - a. The following or equal:
      - 1) Brady.

4. Pre-printed slip-on sleeve markers:
  - a. The following or equal:
    - 1) Grafoplast.
    - 2) Engineer knows of no equal.
- C. Conduit and raceway markers:
  1. One of the following or equal:
    - a. Almetek: Mini Tags.
    - b. Lapp Group: Maxi System.
- D. Medium voltage raceway voltage labels:
  1. One of the following or equal:
    - a. Brady.
    - b. Seton.

## 2.02 MATERIALS

- A. Nameplates:
  1. Fabricated from white-center and red face or black-center, white face laminated plastic engraving stock:
    - a. 3/32-inch thick material.
    - b. Two-ply.
    - c. With chamfered edges.
    - d. Block style engraved characters of adequate size to be read easily from a distance of 6 feet:
      - 1) No characters smaller than 1/8-inch in height.
- B. Signs:
  1. Automatic equipment and high voltage signs:
    - a. Suitable for exterior use.
    - b. In accordance with OSHA regulations.
- C. Conductor and cable markers:
  1. Machine printed black characters on white tubing.
  2. Ten point type or larger.
- D. Conduit and raceway markers:
  1. Non-metallic:
    - a. UV resistant holder and letters
    - b. Black letters on yellow background.
    - c. Minimum letter height: 1/2-inch.
    - d. Adhesive labels are not acceptable.

## 2.03 SOURCE QUALITY CONTROL

- A. Nameplates:
  - 1. Provide all nameplates for control panel operator devices (e.g. pushbuttons, selector switches, pilot lights, etc.):
    - a. Same material and same color and appearance as the device nameplates, in order to achieve an aesthetically consistent and coordinated system.

## PART 3 EXECUTION

### 3.01 INSTALLATION

- A. As specified in Section 26\_05\_00.
- B. Nameplates:
  - 1. Attach nameplates to equipment with rivets, bolts or sheet metal screws, approved waterproof epoxy-based cement or install in metal holders welded to the equipment.
  - 2. On NEMA Type 4, NEMA Type 4X, or NEMA Type 7 enclosures, use epoxy-based cement to attach nameplates.
  - 3. Nameplates shall be aligned and level or plumb to within 1/64 inch over the entire length:
    - a. Misaligned or crooked nameplates shall be remounted, or provide new enclosures at the discretion of the Engineer.
- C. Conductor and cable markers:
  - 1. Apply all conductor and cable markers before termination.
  - 2. Heat-shrinkable tubing:
    - a. Tubing shall be shrunk using a heat gun that produces low temperature heated air.
    - b. Tubing shall be tight on the wire after it has been heated.
    - c. Characters shall face the open panel and shall read from left to right or top to bottom.
    - d. Marker shall start within 1/32 inch of the end of the stripped insulation point.
- D. Conduit markers:
  - 1. Furnish and install conduit markers for every conduit in the electrical system that is identified in the conduit schedule or part of the process system:
    - a. Conduit markings shall match the conduit schedule.
  - 2. Mark conduits at the following locations:
    - a. Each end of conduits that are greater than 10 feet in length.
    - b. Where the conduit penetrates a wall or structure.
    - c. Where the conduit emerges from the ground, slab, etc.
    - d. The middle of conduits that are 10 feet or less in length.
  - 3. Mark conduits after the conduits have been fully painted.
  - 4. Position conduit markers so that they are easily read from the floor.

5. Attach non-metallic conduit markers with nylon cable ties:
    - a. Provide ultraviolet resistant cable ties for conduit markers exposed to direct sunlight.
  6. Mark conduits before construction review by Engineer for punch list purposes.
  7. Label intrinsically safe conduits in accordance with the requirements of the NEC.
- E. Signs and labeling:
1. Furnish and install permanent warning signs at mechanical equipment that may be started automatically or from remote locations:
    - a. Fasten warning signs with round head stainless steel screws or bolts.
    - b. Locate and mount in a manner to be clearly legible to operations personnel.
  2. Furnish and install permanent and conspicuous warning signs on equipment (front and back), doorways to equipment rooms, pull boxes, manholes, etc where the voltage exceeds 600 volts.
  3. Furnish and install warning signs on equipment that has more than one source of power.
    - a. Warning signs to identify every panel and circuit number of the disconnecting means of all external power sources.
  4. Place warning signs on equipment that has 120 VAC control voltage source used for interlocking.
    - a. Identify panel and circuit number or conductor tag for control voltage source disconnecting means.

### **3.02 FIELD QUALITY CONTROL**

- A. Replace any nameplates, signs, conductor markers, cable markers or raceway labels that in the sole opinion of the Engineer do not meet the Engineer's aesthetic requirements.

## **PART 4 MEASUREMENT**

### **4.01 METHOD OF MEASUREMENT**

- A. No separate measurement shall be made for work under this Section.

## **PART 5 PAYMENT**

### **5.01 METHOD OF PAYMENT**

- A. No separate payment will be made for work under this Section. The cost of the work described in this Section shall be included in the applicable lump sum bid item.

END OF SECTION



## SECTION 26\_08\_50

### FIELD ELECTRICAL ACCEPTANCE TESTS

#### PART 1 GENERAL

##### 1.01 SUMMARY

- A. Section includes:
  - 1. Responsibilities for testing the electrical installation.
  - 2. Adjusting and calibration.
  - 3. Acceptance tests.
- B. Related sections:
  - 1. Section 26\_05\_00 - Common Work Results for Electrical.
  - 2. Section 26\_05\_26 - Grounding and Bonding.
- C. Copyright information:
  - 1. Some portions of this Section are copyrighted by the InterNational Electrical Testing Association, Inc (NETA). See NETA publication ATS for details.

##### 1.02 REFERENCES

- A. As specified in Section 26\_05\_00.
- B. American National Standards Institute (ANSI).
- C. ASTM International (ASTM):
  - 1. D877 - Standard Test Method for Dielectric Breakdown Voltage of Insulating Liquids Using Disk Electrodes.
  - 2. D923 - Standard Practices for Sampling Electrical Insulating Liquids.
  - 3. D971 - Standard Test Method for Interfacial Tension of Oil Against Water by the Ring Method.
  - 4. D974 - Standard Test Method for Acid and Base Number by Color-Indicator Titration.
  - 5. D1298 - Standard Test Method for Density, Relative Density, or API Gravity of Crude Petroleum and Liquid Petroleum Products by Hydrometer Method.
  - 6. D1500 - Standard Test Method for ASTM Color of Petroleum Products (ASTM Color Scale).
  - 7. D1524 - Standard Test Method for Visual Examination of Used Electrical Insulating Oils of Petroleum Origin in the Field.
  - 8. D1816 - Standard Test Method for Dielectric Breakdown Voltage of Insulating Liquids Using VDE Electrodes.
  - 9. D2285 - Standard Test Method for Interfacial Tension of Electrical Insulating Oils of Petroleum Origin Against Water by the Drop Weight Method.



10. D3612 - Standard Test Method for Analysis of Gases Dissolved in Electrical Insulating Oil by Gas Chromatography.
- D. Institute of Electrical and Electronics Engineers (IEEE):
1. 43 - IEEE Recommended Practice for Testing Insulation Resistance of Rotating Machinery.
  2. 81 - IEEE Guide for Measuring Earth Resistivity, Ground Impedance, and Earth Surface Potentials of a Grounding System.
  3. 95 - IEEE Recommended Practice for Insulation Testing of AC Electric Machinery (2300 V and Above) With High Direct Voltage.
  4. 421.3 - IEEE Standard for High-Potential Test Requirement for Excitation Systems for Synchronous Machines.
  5. 450 - IEEE Recommended Practice for Maintenance, Testing, and Replacement of Vented Lead-Acid Batteries for Stationary Applications.
  6. 1106 - IEEE Recommended Practice for Installation, Maintenance, Testing, and Replacement of Vented Nickel-Cadmium Batteries for Stationary Applications.
  7. 1188 - IEEE Recommended Practice for Maintenance, Testing, and Replacement of Valve-Regulated Lead-Acid (VRLA) Batteries for Stationary Applications.
  8. C57.13 - IEEE Standard Requirements for Instrument Transformers.
  9. C57.13.1 – IEEE Guide for Field Testing of Relaying Current Transformers.
  10. C57.13.3 - IEEE Guide for Grounding of Instrument Transformer Secondary Circuits and Cases.
  11. C57.104 - IEEE Guide for the Interpretation of Gases Generated in Oil-Immersed Transformers.
- E. Insulated Cable Engineer's Association (ICEA).
- F. InterNational Electrical Testing Association (NETA).
1. ATS-2009 Standard for Standard for Acceptance Testing Specifications for Electrical Power Equipment and Systems.
- G. International Electrotechnical Commission (IEC).
- H. Manufacturer's testing recommendations and instruction manuals.
- I. National Fire Protection Association (NFPA):
1. 70 – National Electrical Code (NEC).
  2. 110 - Standard for Emergency and Standby Power Systems.
- J. National Institute of Standards and Technology (NIST).
- K. Specification sections for the electrical equipment being tested.
- L. Shop drawings.

### 1.03 DEFINITIONS

- A. As specified in Section 26\_05\_00.
- B. Specific definitions:
  - 1. Testing laboratory: The organization performing acceptance tests.

### 1.04 SYSTEM DESCRIPTION

- A. Testing of all electrical equipment installed under this Contract in accordance with the manufacturer's requirements and as specified in this Section.
- B. Conduct all tests in the presence of the Engineer or the Engineer's representative:
  - 1. Engineer will witness all visual, mechanical and electrical tests, and inspections.
- C. The testing and inspections shall verify that the equipment is operational within the tolerances required and expected by the manufacturer, and these Specifications.
- D. Responsibilities:
  - 1. Contractor responsibilities:
    - a. Ensure that all resources are made available for testing, and that all testing requirements are met.
  - 2. Electrical subcontractor responsibilities:
    - a. Perform routine tests during installation.
    - b. Demonstrate operation of electrical equipment.
    - c. Commission the electrical installation.
    - d. Provide the necessary services during testing, and provide these services to the testing laboratory, Contractor, and other subcontractors, including but not limited to:
      - 1) Providing electrical power as required.
      - 2) Operating of electrical equipment in conjunction with testing of other equipment.
      - 3) Activating and shutting down electrical circuits.
      - 4) Making and recording electrical measurements.
      - 5) Replacing blown fuses.
      - 6) Installing temporary jumpers.
  - 3. Testing laboratory responsibilities:
    - a. Perform all acceptance tests specified in this Section.
    - b. Provide all required equipment, materials, labor, and technical support during acceptance tests.
- E. Upon completion of testing or calibration, attach a label to all serviced devices:
  - 1. The label shall indicate the date serviced and the company that performed the service.

## 1.05 SUBMITTALS

- A. Furnish submittals as specified in Section 26\_05\_00.
- B. LAN cable test form:
  - 1. LAN cable test reports:
    - a. Submit 3 copies of test reports showing the results of all tests specified in this Section:
      - 1) Test type.
      - 2) Test location.
      - 3) Test date.
      - 4) Cable number.
      - 5) Cable length.
      - 6) Certification that the cable meets or exceeds the specified standard.
    - b. Furnish hard copy and electronic copy for all traces.
- C. Manufacturers' testing procedures:
  - 1. Submit manufacturers' recommended testing procedures and acceptable test results for review by the Engineer.
- D. Test report:
  - 1. Include the following:
    - a. Summary of Project.
    - b. Description of equipment tested.
    - c. Description of tests performed.
    - d. Test results.
    - e. Conclusions and recommendations.
    - f. Completed test forms.
    - g. List of test equipment used and calibration dates.
    - h. LAN cable test reports.
- E. Testing laboratory qualifications:
  - 1. Submit a complete resume and statement of qualifications from the proposed testing laboratory detailing their experiences in performing the tests specified:
    - a. This statement will be used to determine whether the laboratory is acceptable, and shall include:
      - 1) Corporate history and references.
      - 2) Resume of individual performing test.
      - 3) Equipment list and test calibration data.
- F. Division of responsibilities:
  - 1. Submit a list identifying who is responsible for performing each portion of the testing.

## 1.06 QUALITY ASSURANCE

- A. As specified in Section 26\_05\_00.

- B. Testing laboratory qualifications:
  - 1. The testing laboratory may be qualified testing personnel from the electrical subcontractor's staff or an independent testing company.
  - 2. Selection of the testing laboratory and testing personnel is subject to approval by the Engineer based on testing experience and certifications of the individuals and testing capabilities of the organization.

## 1.07 PROJECT OR SITE CONDITIONS

- A. As specified in Section 26\_05\_00.

## 1.08 SEQUENCING

- A. At least 30 days before commencement of the acceptance tests, submit the manufacturer's complete field testing procedures to the Engineer and to the testing laboratory, complete with expected test results and tolerances for all equipment to be tested.
- B. Perform testing in the following sequence:
  - 1. Perform routine tests as the equipment is installed including:
    - a. Insulation-resistance tests.
    - b. Continuity tests.
    - c. Rotational tests.
  - 2. Adjusting and preliminary calibration.
  - 3. Acceptance tests.
  - 4. Demonstration.
  - 5. Commissioning and plant start-up.

## 1.09 WARRANTY

- A. As specified in Section 26\_05\_00.

## PART 2 PRODUCTS

Not Used.

## PART 3 EXECUTION

### 3.01 PREPARATION

- A. Test instrument calibration:
  - 1. Utilize a testing laboratory with a calibration program which maintains all applicable test instrumentation within rated accuracy.
  - 2. The accuracy shall be traceable to the NIST in an unbroken chain.
  - 3. Calibrate instruments in accordance with the following frequency schedule:
    - a. Field instruments: 6 months maximum.

- b. Laboratory instruments: 12 months maximum.
  - c. Leased specialty equipment where the accuracy is guaranteed by the lessor (such as Doble): 12 months maximum.
  4. Dated calibration labels shall be visible on all test equipment.
  5. Maintain an up-to-date instrument calibration record for each test instrument:
    - a. The records shall show the date and results of each calibration or test.
  6. Maintain an up-to-date instrument calibration instruction and procedure for each test instrument.
- B. Do not begin testing until the following conditions have been met:
1. All instruments required are available and in proper operating condition.
  2. All required dispensable materials such as solvents, rags, and brushes are available.
  3. All equipment handling devices such as cranes, vehicles, chain falls and other lifting equipment are available or scheduled.
  4. All instruction books, calibration curves, or other printed material to cover the electrical devices are available.
  5. Data sheets to record all test results are available.

### 3.02 FIELD QUALITY CONTROL

- A. Dry type transformers:
1. Visual and mechanical inspection:
    - a. Compare equipment nameplate data with the Contract Documents.
    - b. Inspect physical and mechanical condition.
    - c. Inspect anchorage, alignment, and grounding.
    - d. Verify that resilient mounts are free and that any shipping brackets have been removed.
    - e. Inspect equipment for cleanliness.
    - f. Inspect bolted electrical connections for high resistance using one of the following methods:
      - 1) Use of low-resistance ohmmeter.
      - 2) Verify tightness of accessible bolted electrical connections by the calibrated torque wrench method:
        - a) Refer to manufacturer's instructions for proper foot-pound levels or NETA ATS tables.
    - g. Verify that as-left tap connections are as specified.
  2. Electrical tests:
    - a. Perform resistance measurements through bolted connections with a low-resistance ohmmeter.
    - b. Perform insulation-resistance tests winding-to-winding and each winding-to-ground:
      - 1) Apply voltage in accordance with manufacturer's published data.
        - a) Refer to NETA ATS tables in the absence of manufacturer's published data.
    - c. Calculate dielectric absorption ration or polarization index.

- d. Verify correct secondary voltage, phase-to-phase and phase-to-neutral after energization and before loading.
3. Test values:
  - a. Compare bolted connection resistance values to values of similar connections:
    - 1) Investigate values which deviate from those of similar bolted connections by more than 50 percent of the lowest value.
  - b. Bolt-torque levels shall be in accordance with manufacturer's published data:
    - 1) Refer to NETA ATS tables in the absence of manufacturer's published data.
  - c. Tap connections are left as found unless otherwise specified.
  - d. Minimum insulation-resistance values of transformer insulation shall be in accordance with manufacturer's published data:
    - 1) Refer to NETA ATS tables in the absence of manufacturer's published data.
    - 2) Investigate insulation values less than the allowable minimum.
  - e. The dielectric absorption ratio or polarization index shall not be less than 1.0.
  - f. Turns-ratio results should not deviate more than 1/2 percent from either the adjacent coils or calculated ratio.
  - g. Phase-to-phase and phase-to-neutral secondary voltages shall be in agreement with nameplate data.
- B. Low voltage cables, 600 volt maximum:
  1. Visual and mechanical inspection:
    - a. Compare cable data with the Drawings and Specifications.
    - b. Inspect exposed sections of cable for physical damage and correct connection as indicated on the Drawings.
    - c. Inspect bolted electrical connections for high resistance by 1 of the following methods:
      - 1) Use of low-resistance ohmmeter.
      - 2) Verify tightness of accessible bolted electrical connections by the calibrated torque wrench method:
        - a) Refer to manufacturer's instructions for proper foot-pound levels or NETA ATS tables.
    - d. Inspect compression applied connectors for correct cable match and indentation.
    - e. Inspect for correct identification and arrangement.
    - f. Inspect cable jacket insulation and condition.
  2. Electrical tests:
    - a. Perform resistance measurements through bolted connections with a low-resistance ohmmeter.
    - b. Perform insulation resistance test on each conductor with respect to ground and adjacent conductors:
      - 1) Applied potential shall be 500 volts dc for 300 volt rated cable and 1,000 volts dc for 600 volt rated cable.

- 2) Test duration shall be 1 minute.
- c. Perform continuity tests to insure correct cable connection.
- d. Verify uniform resistance of parallel conductors.
3. Test values:
  - a. Compare bolted connection resistance values to values of similar connections:
    - 1) Investigate values which deviate from those of similar bolted connections by more than 50 percent of the lowest value.
  - b. Insulation-resistance values shall be in accordance with manufacturer's published data:
    - 1) Refer to NETA ATS tables in the absence of manufacturer's published data.
    - 2) Investigate values of insulation-resistance less than the allowable minimum.
  - c. Cable shall exhibit continuity.
  - d. Investigate deviations in resistance between parallel conductors.
- C. Low voltage molded case and insulated case circuit breakers:
  1. Visual and mechanical inspection:
    - a. Compare equipment nameplate data with the Contract Documents.
    - b. Inspect physical and mechanical condition.
    - c. Inspect anchorage and alignment.
    - d. Verify that all maintenance devices are available for servicing and operating the breaker.
    - e. Verify the unit is clean.
    - f. Verify the arc chutes are intact.
    - g. Inspect moving and stationary contacts for condition and alignment.
    - h. Verify that primary and secondary contact wipe and other dimensions vital to satisfactory operation of the breaker are correct.
    - i. Perform all mechanical operator and contact alignment tests on both the breaker and its operating mechanism in accordance with manufacturers published data.
    - j. Operate circuit breaker to ensure smooth operation.
    - k. Inspect bolted electrical connections for high resistance by one of the following methods:
      - 1) Use of low-resistance ohmmeter.
      - 2) Verify tightness of accessible bolted electrical connections by the calibrated torque wrench method:
        - a) Refer to manufacturer's instructions for proper foot-pound levels or NETA ATS tables.
    - l. Inspect operating mechanism, contacts, and arc chutes in unsealed units.
    - m. Verify cell fit and element alignment.
    - n. Verify racking mechanism operation.
    - o. Verify appropriate lubrication on moving current-carrying parts and on moving and sliding surfaces.
    - p. Perform adjustments for final protective device settings in accordance with the coordination study.

- q. Record as-found and as-left operation counter readings.
2. Electrical tests:
  - a. Perform resistance measurements through bolted connections with a low-resistance ohmmeter.
  - b. Perform insulation-resistance tests for 1 minute on each pole, phase-to-phase and phase-to-ground with the circuit breaker closed and across each open pole:
    - 1) Apply voltage in accordance with manufacturer's published data.
    - 2) Refer to NETA ATS tables in the absence of manufacturer's published data.
  - c. Perform a contact/pole-resistance test.
  - d. Determine long-time pickup and delay by primary current injection.
  - e. Determine short-time pickup and delay by primary current injection.
  - f. Determine ground-fault pickup and delay by primary current injection.
  - g. Determine instantaneous pickup value by primary current injection.
  - h. Perform minimum pickup voltage tests on shunt trip and close coils in accordance with manufacturer's published data.
  - i. Verify correct operation of any auxiliary features such as trip and pickup indicators, zone interlocking, electrical close and trip operation, trip-free, anti-pump function and trip unit battery condition:
    - 1) Reset all trip logs and indicators.
  - j. Verify operation of charging mechanism.
3. Test values:
  - a. Compare bolted connection resistance values to values of similar connections:
    - 1) Investigate values which deviate from those of similar bolted connections by more than 50 percent of the lowest value.
  - b. Bolt-torque levels shall be in accordance with manufacturer's published data:
    - 1) Refer to NETA ATS tables in the absence of manufacturer's published data.
  - c. Insulation-resistance values shall be in accordance with manufacturer's published data:
    - 1) Refer to NETA ATS tables in the absence of manufacturer's published data.
    - 2) Investigate values of insulation-resistance less than the allowable minimum.
  - d. Microhm or dc millivolt drop values shall not exceed the high levels of the normal range as indicated in the manufacturer's published data:
    - 1) If manufacturer's data is not available, investigate any values which deviate from adjacent poles or similar breakers by more than 50 percent of the lowest value.



- e. Long-time pickup values shall be as specified, and the trip characteristic shall not exceed manufacturer's published time-current characteristic tolerance band including adjustment factors:
    - 1) If manufacturer's curves are not available, trip times shall not exceed the value shown in NETA ATS tables.
  - f. Short-time pickup values shall be as specified, and the trip characteristic shall not exceed manufacturer's published time-current tolerance band.
  - g. Ground fault pickup values shall be as specified, and the trip characteristic shall not exceed manufacturer's published time-current tolerance band.
  - h. Instantaneous pickup values shall be as specified and within manufacturer's published tolerances:
    - 1) Refer to NETA ATS tables in the absence of manufacturer's published data.
  - i. Pickup values and trip characteristics shall be within manufacturer's published tolerances.
  - j. Minimum pickup voltage of the shunt trip and close coils shall conform to the manufacturer's published data:
    - 1) Refer to NETA ATS tables in the absence of manufacturer's published data.
  - k. Breaker open, close, trip, trip-free, anti-pump, and auxiliary features shall function as designed.
  - l. The charging mechanism shall operate in accordance with manufacturer's published data.
- D. Instrument transformers:
- 1. Visual and mechanical inspection:
    - a. Compare equipment nameplate data with the Contract Documents.
    - b. Inspect physical and mechanical condition.
    - c. Verify correct connection of transformers with system requirements.
    - d. Verify that adequate clearances exist between primary and secondary circuit wiring.
    - e. Verify the unit is clean.
    - f. Inspect bolted electrical connections for high resistance using one of the following methods:
      - 1) Use of low-resistance ohmmeter.
      - 2) Verify tightness of accessible bolted electrical connections by calibrated torque wrench method:
        - a) Refer to manufacturer's instructions for proper foot-pound levels or NETA ATS tables.
    - g. Verify that all required grounding and shorting connections provide contact.
    - h. Verify correct operation of transformer withdrawal mechanism and grounding operation.
    - i. Verify correct primary and secondary fuse sizes for voltage transformers.
    - j. Verify appropriate lubrication on moving current-carrying parts and on moving and sliding surfaces.
    - k. Verify instrument transformer polarities match the 3-line diagrams.

2. Electrical tests - current transformers:
  - a. Perform resistance measurements through bolted connections with a low-resistance ohmmeter.
  - b. Perform insulation-resistance test of each current transformer and its secondary wiring with respect to ground at 1,000 VDC for 1 minute:
    - 1) For solid state devices that cannot tolerate the applied voltage, follow the manufacturer's recommendation.
  - c. Perform a polarity test of each current transformer in accordance with IEEE C57.13.1.
  - d. Perform a ratio verification test using the voltage or current method in accordance with IEEE C57.13.1.
  - e. Perform an excitation test on current transformers used for relaying applications in with accordance with IEEE C57.13.1.
  - f. Measure current circuit burdens at transformer terminals in accordance with IEEE C57.13.1.
  - g. Perform an excitation test on transformers used for relaying applications in accordance with IEEE C57.13.1.
  - h. When applicable perform insulation-resistance tests on the primary winding with the secondary grounded:
    - 1) Test voltages shall be in accordance with NETA ATS tables.
  - i. When applicable perform dielectric withstand tests on the primary winding with the secondary grounded:
    - 1) Test voltages shall be in accordance with NETA ATS tables.
  - j. Perform power-factor or dissipation-factor tests in accordance with test equipment manufacturer's published data.
  - k. Verify that current transformer secondary circuits are grounded and have only 1 grounding point in accordance with IEEE C57.13.3:
    - 1) That grounding point should be located as specified by the Engineer in the Contract Documents.
3. Electrical tests - voltage transformers:
  - a. Perform resistance measurements through bolted connections with a low-resistance ohmmeter.
  - b. Perform insulation-resistance tests winding-to-winding and winding-to-ground:
    - 1) Test voltage shall be applied for 1 minute in accordance with NETA ATS requirements.
    - 2) For solid state devices that cannot tolerate the applied voltage, follow the manufacturer's recommendation.
  - c. Perform a polarity test on each voltage transformer to verify the polarity marks on H<sub>1</sub>- X<sub>1</sub> relationship as applicable.
  - d. Perform a turns ratio test on all tap positions.
  - e. Measure voltage circuit burdens at transformer terminals.
  - f. Perform a dielectric withstand test on the primary windings with the secondary windings grounded:
    - 1) The dielectric voltage shall be in accordance with NETA ATS tables.
    - 2) Apply the test voltage for 1 minute.

- g. Perform power-factor or dissipation-factor tests in accordance with test equipment manufacturers published data.
  - h. Verify that voltage transformer secondary circuits are grounded and have only 1 grounding point in accordance with IEEE C57.13.3:
    - 1) That grounding point should be located as specified by the Engineer in the Contract Documents.
4. Test values:
- a. Compare bolted connection resistance values to values of similar connections:
    - 1) Investigate values which deviate from those of similar bolted connections by more than 50 percent of the lowest value.
  - b. Bolt-torque levels shall be in accordance with manufacturer's published data:
    - 1) Refer to NETA ATS tables in the absence of manufacturer's published data.
  - c. Insulation-resistance values of instrument transformers shall be in accordance with manufacturer's published data:
    - 1) Refer to NETA ATS tables in the absence of manufacturer's published data.
  - d. Polarity results shall agree with transformer markings.
  - e. Ratio errors shall be in accordance with IEEE C57.13.
  - f. Excitation results for current transformers shall match the curve supplied by the manufacturer or be in accordance with IEEE C57.13.1.
  - g. Measured burdens shall be compared to instrument transformer ratings.
  - h. If no evidence of distress or insulation failure is observed by the end of the total time of voltage application during the dielectric withstand test, the current transformer primary winding is considered to have passed the test.
  - i. Power-factor or dissipation-factor values shall be compared to manufacturer's published data:
    - 1) In the absence manufacturer's published data the comparison shall be made to similar breakers.
  - j. Test results shall indicate that the circuits have only 1 grounding point.
- E. Metering devices:
- 1. Visual and mechanical inspection:
    - a. Compare equipment nameplate data with the Contract Documents.
    - b. Inspect physical and mechanical condition.
    - c. Inspect bolted electrical connections for high resistance using one of the following methods:
      - 1) Use of low-resistance ohmmeter.
      - 2) Verify tightness of accessible bolted electrical connections by calibrated torque wrench method:
        - a) Refer to manufacturer's instructions for proper foot-pound levels or NETA ATS tables.
    - d. Record model number, serial number, firmware revision, software revision, and rated control voltage.
    - e. Verify operation of display and indicating devices.

- f. Record passwords.
  - g. Verify unit is grounded in accordance with manufacturer's instructions.
  - h. Set all required parameters including instrument transformer ratios, system type, frequency, power demand methods/intervals, and communications requirements.
  - i. Inspect cover gasket, cover glass, condition of spiral spring, disk clearance, contacts, and case shorting contacts as applicable.
  - j. Verify the unit is clean.
2. Electrical tests:
    - a. Apply voltage or current as appropriate to each analog input and verify correct measurement and indication.
    - b. Confirm correct operation and setting of each auxiliary input/output feature including mechanical relay, digital, and analog.
    - c. After initial system energization, confirm measurements and indications are consistent with loads present.
    - d. Perform resistance measurements through bolted connections with a low-resistance ohmmeter.
    - e. Verify accuracy of meter at all cardinal points.
    - f. Calibrate meters in accordance with manufacturer's published data.
    - g. Verify that current transformer, and voltage transformer secondary circuits are intact.
  3. Test values:
    - a. Compare bolted connection resistance values to values of similar connections:
      - 1) Investigate values which deviate from those of similar bolted connections by more than 50 percent of the lowest value.
    - b. Bolt-torque levels shall be in accordance with manufacturer's published data:
      - 1) Refer to NETA ATS tables in the absence of manufacturer's published data.
    - c. Meter accuracy shall be in accordance with manufacturer's published data.
    - d. Calibration results shall be within manufacturer's published tolerances.
    - e. Instrument multipliers shall be in accordance with system design specifications.
    - f. Test results shall confirm the integrity of the secondary circuits of current and voltage transformers.
- F. Grounding systems:
1. Visual and mechanical inspection:
    - a. Inspect ground system for compliance with that indicated on the Drawings, specified in Specifications, and in the NEC.
    - b. Inspect physical and mechanical condition.
    - c. Inspect bolted electrical connections for high resistance using one of the following methods:
      - 1) Use of low-resistance ohmmeter.

- 2) Verify tightness of accessible bolted electrical connections by calibrated torque wrench method:
  - a) Refer to manufacturer's instructions for proper foot-pound levels or NETA ATS tables.
  - d. Inspect anchorage.
2. Electrical tests:
  - a. Perform resistance measurements through bolted connections with a low-resistance ohmmeter.
  - b. Perform fall of potential test or alternative test in accordance with IEEE 81 on the main grounding electrode or system.
  - c. Perform point-to-point tests to determine the resistance between the main grounding system and all major electrical equipment frames, the system neutral and any derived neutral points.
3. Test values:
  - a. Grounding system electrical and mechanical connections shall be free of corrosion.
  - b. Compare bolted connection resistance values to values of similar connections:
    - 1) Investigate values which deviate from those of similar bolted connections by more than 50 percent of the lowest value.
  - c. Bolt-torque levels shall be in accordance with manufacturer's published data:
    - 1) Refer to NETA ATS tables in the absence of manufacturer's published data.
  - d. The resistance between the main grounding electrode and ground shall be as specified in Section 26\_05\_26. Investigate point-to-point resistance values that exceed 0.5 ohm.
- G. Surge arresters, low-voltage:
  1. Visual and mechanical inspection:
    - a. Compare equipment nameplate data with the Contract Documents.
    - b. Inspect physical and mechanical condition.
    - c. Inspect anchorage, alignment, grounding, and clearances.
    - d. Verify the arresters are clean.
    - e. Inspect bolted electrical connections for high resistance using one of the following methods:
      - 1) Use of low-resistance ohmmeter.
      - 2) Verify tightness of accessible bolted electrical connections by the calibrated torque wrench method:
        - a) Refer to manufacturer's instructions for proper foot-pound levels or NETA ATS tables.
    - f. Verify that the ground lead on each device is individually attached to a ground bus or ground electrode.
    - g. Verify that stroke counter is correctly mounted and electrically connected, if applicable.
    - h. Record stroke counter reading.

2. Electrical tests:
    - a. Perform resistance measurements through bolted connections with a low-resistance ohmmeter.
    - b. Perform an insulation-resistance test on each arrester, phase terminal- to- ground:
      - 1) Apply voltage in accordance with manufacturers published data.
      - 2) Refer to NETA ATS tables in the absence of manufacturer's published data.
    - c. Test grounding connection as specified in this Section.
  3. Test values:
    - a. Compare bolted connection resistance values to values of similar connections:
      - 1) Investigate values which deviate from those of similar bolted connections by more than 50 percent of the lowest value.
    - b. Bolt-torque levels shall be in accordance with manufacturer's published data:
      - 1) Refer to NETA ATS tables in the absence of manufacturer's published data.
    - c. Insulation-resistance values shall be in accordance with manufacturer's published data:
      - 1) Refer to NETA ATS tables in the absence of manufacturer's published data.
      - 2) Investigate insulation values less than the allowable minimum.
    - d. Resistance between the arrester ground terminal and the ground system shall be less than 0.5 ohm.
- H. Fiber-optic cables:
1. Visual and mechanical inspection:
    - a. Compare cable, connector, and splice data with the Contract Documents:
    - b. Inspect cable and connections for physical and mechanical damage.
    - c. Verify that all connectors and splices are correctly installed.
  2. Electrical tests:
    - a. Perform cable length measurement, fiber fracture inspection, and construction defect inspection using an optical time domain reflectometer (OTDR):
      - 1) OTDR test performed on fiber cables less than 100 meters shall be performed with the aid of a launch cable.
      - 2) Adjust OTDR pulse width settings to a maximum setting of 1/1,000th of the cable length or 10 nanoseconds.
    - b. Perform connector and splice integrity test using an optical time domain reflectometer.
    - c. Perform cable attenuation loss measurement with an optical power loss test set:
      - 1) Perform attenuation tests with an Optical Loss Test Set capable and calibrated to show anomalies of 0.1 dB as a minimum.
      - 2) Test multimode fibers at 850 nanometer and 1,300 nanometer.
      - 3) Test single mode fibers at 1,310 nanometer and 1,550 nanometer.

- d. Perform connector and splice attenuation loss measurement from both ends of the optical cable with an optical power loss test set:
    - 1) At the conclusion of all outdoor splices at 1 location, and before they are enclosed and sealed, all splices shall be tested with OTDR at the optimal wavelengths (850 and 1,300 for multimode, 1,310 and 1,550 for single mode), in both directions. The splices shall be tested for integrity as well as attenuation.
  - e. Perform fiber links integrity and attenuation tests using each link shall be an OTDR and an Optical Loss Test Set:
    - 1) OTDR traces shall be from both directions on each fiber at the 2 optimal wavelengths, 850 nanometer, and 1,300 nanometer for multimode fibers.
    - 2) Optical loss testing shall be done with handheld test sets in 1 direction at the 2 optimal wavelengths for the appropriate fiber type. Test equipment shall equal or exceed the accuracy and resolution of Agilent/HP 8147 high performance OTDR.
3. Test values:
- a. Cable and connections shall not have been subjected to physical or mechanical damage.
  - b. Connectors and splices shall be installed in accordance with industry standards.
  - c. The optical time domain reflectometer signal should be analyzed for excessive connection, splice, or cable backscatter by viewing the reflected power/distance graph.
  - d. Attenuation loss measurement shall be expressed in dB/km. Losses shall be within the manufacturer's recommendations when no local site specifications are available.
  - e. Individual fusion splice losses shall not exceed 0.1 dB. Measurement results shall be recorded, validated by trace, and filed with the records of the respective cable runs.
- I. LAN cable testing:
1. Visual and mechanical inspections:
    - a. Compare cable type and connections with that indicated on the Drawings and specified in the Specifications.
    - b. Inspect cable and connectors for physical and mechanical damage.
    - c. Verify that all connectors are correctly installed.
  2. Pre-testing:
    - a. Test individual cables before installation:
      - 1) Before physical placement of the cable, test each cable while on the spool with a LAN certification test device.
      - 2) Before the cable is installed, verify that the cable conforms to the manufacturer's attenuation specification and that no damage has been done to the cable during shipping or handling.
      - 3) The test shall be fully documented and the results submitted to the Engineer, including a hard copy of all traces, before placement of the cable.

- 4) The Engineer shall be notified if a cable fails to meet specification and the cable shall not be installed unless otherwise directed by the Engineer.
3. Electrical tests:
  - a. Perform cable end-to-end testing on all installed cables after installation of connectors from both ends of the cable.
  - b. Test shall include cable system performance tests and confirm the absence of wiring errors.
4. Test results:
  - a. Cables shall meet or exceed TIA standards for a Category 6 installation.
5. Test equipment:
  - a. LAN certification equipment used for the testing shall be capable of testing Category 6 cable installation to TIA proposed Level III accuracy. Tests performed shall include:
    - 1) Near end cross talk.
    - 2) Attenuation.
    - 3) Equal level far end cross talk.
    - 4) Return loss.
    - 5) Ambient noise.
    - 6) Effective cable length.
    - 7) Propagation delay.
    - 8) Continuity/loop resistance.
  - b. LAN certification test equipment shall be able to store and produce plots of the test results.
  - c. Acceptable manufacturers: The following or equal:
    - 1) Agilent Technologies, WireScope 350.

### **3.03 CLEANING**

- A. As specified in Section 26\_05\_00.
- B. After the acceptance tests have been completed, dispose of all testing expendables, vacuum all cabinets, and sweep clean all surrounding areas.

### **3.04 PROTECTION**

- A. As specified in Section 26\_05\_00.

## **PART 4 MEASUREMENT**

### **4.01 METHOD OF MEASUREMENT**

- A. No separate measurement shall be made for work under this Section.



## **PART 5 PAYMENT**

### **5.01 METHOD OF PAYMENT**

- A. No separate payment will be made for work under this Section. The cost of the work described in this Section shall be included in the applicable lump sum bid item.

END OF SECTION

## SECTION 26\_43\_14

### SURGE PROTECTIVE DEVICES

#### PART 1 GENERAL

##### 1.01 SUMMARY

- A. Section includes:
  - 1. High-energy surge protective devices.
- B. Related sections:
  - 1. Section 26\_05\_00 - Common Work Results for Electrical.
  - 2. Section 26\_08\_50 - Field Electrical Acceptance Tests.

##### 1.02 REFERENCES

- A. As specified in Section 26\_05\_00.
- B. Institute of Electrical and Electronics Engineers (IEEE):
  - 1. C62.41 – Recommended Practice on Surge Voltages in Low Voltage AC Power Circuits.
  - 2. C62.45 – Guide on Surge Testing for Equipment Connected to Low-Voltage (1000 V and Less) AC Power Circuits.
  - 3. C62.62- Standard Test Specifications for Surge Protective Devices for Low Voltage AC Power Circuits.
- C. Underwriters Laboratory:
  - 1. 1449, 4th Edition, Standard for Surge Protective Devices.

##### 1.03 DEFINITIONS

- A. As specified in Section 26\_05\_00.
- B. Specific definitions:
  - 1. SPD: Surge protective device.
  - 2. SAD: Silicon avalanche diode.
  - 3. MOV: Metal oxide varistor.
  - 4. MCOV: Maximum continuous operating voltage.
  - 5. I<sub>n</sub>: Nominal discharge current.
  - 6. VPR: Voltage protection rating.
  - 7. SCCR: Short circuit current rating.

##### 1.04 SYSTEM DESCRIPTION

- A. Surge protective devices as an integral component of the electrical equipment or externally mounted as indicated on the Drawings.

## 1.05 SUBMITTALS

- A. Furnish submittals as specified in Section 26\_05\_00.
- B. Product data:
  - 1. Furnish complete product data confirming detailed compliance or exception statements to all provisions of this Section.
  - 2. Manufacturer's catalog cut sheets indicating:
    - a. Manufacturer and model numbers.
    - b. Ratings of each SPD including but not limited to:
      - 1) Short circuit current rating.
      - 2) Nominal discharge current.
      - 3) Maximum continuous operating voltage.
      - 4) Voltage protection rating.
      - 5) System voltage.
      - 6) System frequency.
      - 7) Surge current capacity.
  - 3. Submit independent test data from a nationally recognized testing laboratory verifying the following:
    - a. Overcurrent protection.
    - b. UL 1449.
- C. Shop drawings:
  - 1. Provide electrical and mechanical drawings by the manufacturer that detail:
    - a. Unit dimensions.
    - b. Weights.
    - c. Components.
    - d. Field connection locations.
    - e. Mounting provisions.
    - f. Connection details.
    - g. Wiring diagram.
- D. Operation and maintenance manuals:
  - 1. Provide the manufacturer's manual with installation, start-up, spare parts lists, and operating instructions for the specified system.

## 1.06 QUALITY ASSURANCE

- A. As specified in Section 26\_05\_00.
- B. Provide SPD units that are designed, manufactured, tested and installed in compliance with the following codes and standards:
  - 1. Institute of Electrical and Electronics Engineers (IEEE C62.41, C62.45, C62.62).
  - 2. Federal Information Processing Standards Publication 94 (FIPS PUB 94).
  - 3. National Electrical Manufacturer Association.
  - 4. National Fire Protection Association (NFPA 20, 75 and 780).

5. National Electric Code (NFPA 70).
6. Underwriters Laboratories (UL 1449 4th Edition and UL 1283).
7. International Electrotechnical Commission (IEC 801).

### **1.07 DELIVERY, STORAGE, AND HANDLING**

- A. As specified in Section 26\_05\_00.

### **1.08 PROJECT OR SITE CONDITIONS**

- A. As specified in Section 26\_05\_00.

### **1.09 SEQUENCING**

- A. Coordinate with and provide SPD equipment to the electrical equipment manufacturer before final assembly and factory testing.

### **1.10 WARRANTY**

- A. As specified in Section 26\_05\_00.
- B. Extended warranty:
  1. Furnish a manufacturer's full 5-year parts and labor warranty from date of shipment against any part failure when installed in compliance with manufacturer's written instructions, UL listing requirements, and any applicable national, state, or local electrical codes.
  2. Warranty shall include:
    - a. Direct, factory trained employees must be available within 48 hours for assessment of the problem.
    - b. A 24-hour toll-free 800-number for warranty support.

### **1.11 SYSTEM START-UP**

- A. As specified in Section 26\_05\_00.

## **PART 2 PRODUCTS**

### **2.01 MANUFACTURERS**

- A. One of the following or equal:
  1. Liebert.
  2. Eaton/Cutler-Hammer.
  3. Schneider Electric/Square D.
  4. General Electric.

## 2.02 MANUFACTURED UNITS

- A. Provide Type 1 or Type 2 SPD units as required for the locations indicated on the Drawings.
- B. Electrical requirements:
1. SPD ratings are to be consistent with the nominal system operating voltage, phase, and configuration as indicated on the Drawings.
  2. MCOV:
    - a. For the SPD and all components in the suppression path (including all MOVs, SADs, and selenium cells): Greater than 115 percent of the nominal system operating voltage.
  3. Operating frequency:
    - a. 47 to 63 hertz.
  4. SCCR:
    - a. 65 kAIC minimum, but not less than the equipment it is connected to as indicated on the Drawings.
    - b. The SCCR shall be marked on the SPD in accordance with UL 1449 and the NEC.
  5. Nominal discharge current  $I_n$ :
    - a. 20 kA.
  6. Maximum VPR:

| Modes         | <u>240/120</u> | <u>208Y/120</u> | 480Y/277 |
|---------------|----------------|-----------------|----------|
| L-N, L-G, N-G | 900            | 900             | 1,500    |
| L-L           | 1,200          | 1,200           | 2000     |
  7. Peak surge current:
    - a. Service entrance locations:
      - 1) 240 kA per phase minimum.
      - 2) 120 kA per mode minimum.
    - b. Branch locations:
      - 1) 120 kA per phase, minimum.
      - 2) 60 kA per mode minimum.
- C. Protection modes:
1. Provide SPD protection modes as follows:
    - a. Line to Neutral (L-N) where applicable.
    - b. Line to Ground (L-G).
    - c. Neutral to Ground (N-G), where applicable.
- D. Environmental requirements:
1. Storage temperature:
    - a. -40 degrees to +50 degrees Celsius.
  2. Operating temperature:
    - a. -0 degrees to +60 Celsius.

3. Relative humidity:
    - a. 5 percent to 95 percent.
  4. Audible noise:
    - a. Less than 45 dBa at 5 feet (1.5 m).
  5. Operating altitude:
    - a. Zero to 12,000 feet above sea level.
- E. Provide surge protective devices that are suitable for application in IEEE C62.41 Category A, B and C3 environments, as tested to IEEE C62.45.

## 2.03 COMPONENTS

- A. Enclosure:
1. Located in electrical equipment as indicated on the Drawings.
  2. External mounting:
    - a. NEMA Type 4X enclosure:
      - 1) No ventilation openings.
    - b. Hinged cover requiring a tool for internal access.
    - c. Internal drawing pocket.
    - d. All monitoring indications must be visible without opening the door.
- B. Internal connections:
1. Provide low impedance copper plates for intra-unit connections:
    - a. Attach surge modules using bolted connections to the plates for low impedance connections.
  2. Size all connections, conductors, and terminals for the specified surge current capacity.
- C. Surge diversion modules:
1. MOV:
    - a. Where multiple MOVs are used in parallel, utilize computer matched MOVs to within 1 volt variance and tested for manufacturer's defects.
- D. Overcurrent protection:
1. Individually fuse all components, including suppression, filtering, and monitoring components:
    - a. Rated to allow maximum specified nominal discharge current capacity.
    - b. Overcurrent protection that limits specified surge currents is not acceptable.
- E. Connections:
1. Provide terminals to accommodate wire sizes up to #2 AWG.

## 2.04 ACCESSORIES

- A. Unit status indicators:
  - 1. Provide red and green solid-state indicators, with printed labels, on the front cover to redundantly indicate on-line unit status:
    - a. The absence of the green light and the presence of the red light indicate that surge protection is reduced and service is needed to restore full operation.
    - b. Indicates the status of protection on each mode or phase.
- B. Dry contacts for remote monitoring:
  - 1. Electrically isolated Form C dry contacts (1 A/125 VAC) for remote monitoring of system integrity, and indication of under voltage, phase and/or power loss.
- C. Provide an audible alarm which activates under any fault condition.
  - 1. Provide an alarm On/Off switch to silence the alarm.
  - 2. A visible LED will confirm whether alarm is On or Disabled.
  - 3. Locate both switches and the audible alarm on the unit's front cover.

## 2.05 SOURCE QUALITY CONTROL

- A. Permanently affix surge rating to the SPD.
- B. Perform manufacturer's standard factory test.
  - 1. Perform testing in accordance with UL 1449.

## PART 3 EXECUTION

### 3.01 INSTALLATION

- A. As specified in Section 26\_05\_00.
- B. Follow the manufacturer's recommended installation practices and comply with all applicable codes.
- C. Special techniques:
  - 1. Install the SPD with as short and straight conductors including ground conductor as practically possible:
    - a. Twist the input conductors together to reduce input conductor inductance.
  - 2. Do not subject SPD to insulation resistance testing.

### 3.02 FIELD QUALITY CONTROL

- A. As specified in Section 26\_08\_50.

### **3.03 PROTECTION**

- A. As specified in Section 26\_05\_00.

## **PART 4 MEASUREMENT**

### **4.01 METHOD OF MEASUREMENT**

- A. No separate measurement shall be made for work under this Section.

## **PART 5 PAYMENT**

### **5.01 METHOD OF PAYMENT**

- A. No separate payment will be made for work under this Section. The cost of the work described in this Section shall be included in the applicable lump sum bid item.

END OF SECTION





# DIVISION 31 – EARTHWORK

Pond 001 Expansion

Construction Contract No. 201737313

## Denver International Airport Denver, Colorado

Sponsored By:  
City & County of Denver Department of Aviation

Issued for Construction  
November 21, 2017



## SECTION 31\_05\_19.14

### GEOTEXTILES

#### PART 1 - GENERAL

##### 1.01 DESCRIPTION

- A. Furnish all labor, materials, equipment, and incidentals required to install geotextile(s) complete as shown on the Drawings and as specified herein.

##### 1.02 RELATED WORK

- A. Site Preparation is included in Section P-151.
- B. Excavation and Embankment are included in Section P-152.
- C. Trenching, Backfilling, and Compaction are included in Sections P-152 and D-701.
- D. Geocomposite Drainage Nets are included in Section 31\_05\_19.15.
- E. Fiber Reinforced Polypropylene (RPP) Liner is included in Section 31\_05\_19.17.

##### 1.03 SUBMITTALS

- A. Submit to the Engineer, within 10 calendar days following the Effective Date of the Agreement, the following information:
  - 1. Manufacturer's background information.
  - 2. List of material properties and samples of geotextile with attached certified test results.
  - 3. Shop drawing, including:
    - a. Proposed panel layout showing the installation layout identifying field seams as well as any variance or additional details that deviate from the Drawings.
    - b. Details of overlap and seaming of the geotextile, anchoring, connections, and other construction details.
  - 4. Installation schedule.
  - 5. Copy of quality control certificates in conformance with paragraph 2.02 below.

##### 1.04 REFERENCE STANDARDS

- A. American Society for Testing and Materials (ASTM).
  - 1. ASTM D5261 - Standard Test Method for Mass Per Unit Area (Weight) of Fabric.

2. ASTM D4491 - Standard Test Methods for Water Permeability of Geotextiles by Permittivity.
  3. ASTM D4533 - Standard Test Method for Trapezoid Tearing Strength of Geotextiles.
  4. Geotextiles.
  5. ASTM D4632 - Standard Test Method for Grab Breaking Load and Elongation of Geotextiles.
  6. ASTM D4751 - Standard Test Method for Determining Apparent Opening Size of a Geotextile.
  7. ASTM D6241 - Standard Method for Static Puncture Strength of Geotextiles and Geotextile-Related Products Using a 50-mm Probe.
  8. ASTM D5199 - Standard Test Method for Measuring Nominal Thickness of Geotextiles and Geomembranes.
- B. Where reference is made to one of the above standards, the revision in effect at the time of bid opening shall apply.

### **1.05 QUALITY ASSURANCE**

- A. The quality control and quality assurance consists of conformance testing of the material delivered to the site and field quality control during installation.
- B. Conformance testing requirements are discussed in paragraph 2.04 below. The purpose of conformance testing is to assure that the supplied material conforms to this Section and to the manufacturer's quality control certificates.
- C. Field quality control requirements are discussed in paragraph 3.03 below. The purpose of field quality control procedures is to assure that the geotextile material has been installed in accordance with this Section and manufacturer's recommendations.

### **1.06 DELIVERY, STORAGE, AND HANDLING**

- A. The geotextile shall be shipped, stored, and handled in accordance with manufacturer's recommendations and as specified herein.
- B. No mechanical equipment shall be driven directly on top of the geotextile.
- C. The geotextile shall be stored in such a way that it is protected from prolonged exposure to ultraviolet radiation and shall be elevated from the ground (a minimum of 3-in) to protect the geotextile from standing water.

### **1.07 PROJECT/SITE REQUIREMENTS**

- A. The subgrade shall be inspected and approved by the manufacturer and Engineer prior to installation of the geotextile. The subgrade shall be maintained in a smooth, uniform, and compacted condition during the installation of the geotextile.

## 1.08 MATERIAL WARRANTY

- A. The geotextile manufacturer shall warrant the material against manufacturing defects and material degradation for a period of 20 years from the date of installation. The manufacturer shall replace any material that fails from the above causes within the warranty period. The manufacturer shall furnish a written warranty covering the requirements of this paragraph.

## 1.09 GUARANTEE

- A. The Contractor shall guarantee the geotextile against defects in installation and workmanship for the period of 1 year commencing with the date of Final Acceptance. The guarantee shall include the services of qualified service technicians and all materials required for the repairs at no expense to the Owner.

## PART 2 - PRODUCTS

### 2.01 GENERAL

- A. The use of a manufacturer's name and model or catalog number is for the purpose of establishing the standard of quality and general configuration.

### 2.02 MATERIALS

- A. Nonwoven Geotextile(s)
- The geotextile(s) shall be a nonwoven needle-punched material consisting of continuous filaments or multifilament yarns formed into a stable network. The material shall be nonbiodegradable, nonreactive within a pH range of 3 to 11, resistant to ultraviolet light exposure, and shall meet the following minimum average roll values:

| <b>MINIMUM AVERAGE ROLL VALUES</b> |                                   |                        |              |
|------------------------------------|-----------------------------------|------------------------|--------------|
| <b>Properties</b>                  | <b>Test Method</b>                | <b>Unit</b>            | <b>Value</b> |
| Fabric Weight                      | ASTM D5261                        | oz/sq yd               | 16.0         |
| Grab Strength                      | ASTM D4632                        | lb                     | 380          |
| Grab Elongation                    | ASTM D4632                        | percent                | 50           |
| Puncture Resistance                | ASTM D6241                        | lb                     | 1,080        |
| Mullen Burst Strength              | ASTM D3786                        | psi                    | 750          |
| Water Flow Rate                    | ASTM D4491                        | gpm/ft <sup>2</sup> 50 |              |
| Permittivity                       | ASTM D4491 SEC <sup>-1</sup> 0.70 |                        |              |
| Coef. of Permeability              | ASTM D4491                        | cm/sec                 | 0.27         |
| Equivalent                         | ASTM D4751                        |                        |              |
| Opening Size                       | Sieve                             | 60                     | 100          |

- The values listed above are for the weaker principal direction.

3. Nonwoven geotextile(s) shall be manufactured by Mirafi; Serrot; Spartan Technology; Propex Geosynthetics; or by an approved manufacturer meeting the above physical properties.

## 2.03 QUALITY CONTROL DOCUMENTATION

- A. Prior to installation commencement of any geotextile material, provide to the Owner the following information certified by the manufacturer for the delivered geotextile.
  1. Each roll delivered to the site shall have the following identification information:
    - a. Manufacturer's name.
    - b. Product identification.
    - c. Thickness.
    - d. Roll number.
    - e. Roll dimensions.
    - f. Grab Tensile.

## 2.04 CONFORMANCE TESTING

- A. At the discretion of the Owner, conformance testing may be performed by an independent Quality Assurance Laboratory (QAL) approved by the Owner. Engineer shall obtain samples from the delivered material, mark the machine direction, lot number, and roll identification number. Two samples shall be taken per 100,000-ft<sup>2</sup>, or two samples per lot, whichever results in the greater number of conformance tests. This sampling frequency may be increased as deemed necessary by the Engineer. The samples shall be taken across the entire roll width and shall not include the first 3-ft. The following conformance tests shall be conducted at the laboratory.
  1. Mass per unit area (ASTM D3776).
  2. Mullen burst strength (ASTM D3786).
  3. Puncture resistance (ASTM D4833).
  4. Grab tensile (ASTM D4632).
  5. Permittivity (ASTM D4491).
  6. Apparent opening size (ASTM D4751).
- B. These conformance tests shall be performed in accordance with test requirements paragraph 2.02 above and conducted in accordance with ASTM D4759.
- C. All conformance test results shall be reviewed by the Engineer and accepted or rejected, prior to the deployment of the geotextile. All test results shall meet, or exceed, the property values listed in paragraph 2.02 above.

- D. The manufacturer reserves the right to obtain additional samples from rolls immediately before and after the failing roll or as directed by the Engineer and have them tested by the QAL at the Contractor's own expense. If these rolls pass, then only the failing roll will be rejected. If they fail, then the entire lot will be rejected.

## **PART 3 - EXECUTION**

### **3.01 PREPARATION**

- A. General
1. Preparation of the subgrade shall be in accordance with Technical Specifications Section 31\_05\_19.17.

### **3.02 INSTALLATION**

- A. Panel Placement
1. The geotextile shall be installed as shown on the Drawings and in accordance with the manufacturer's recommendations and approved shop drawings. The number of rolls and installed surface area should be documented on a panel layout sheet.
  2. No mechanical equipment shall be driven directly on top of the geotextile.
  3. The subgrade shall be maintained in a smooth, uniform, and compacted condition during installation of the geotextile.
  4. Concrete pavement shall be installed in accordance with Technical Specification Section P-610.
  5. Concrete pavement shall be placed with mechanical equipment; however, no mechanical equipment shall be allowed directly on top of the geotextile material. Equipment may be driven fully-cured pavement sections as directed by the Engineer.
  6. Concrete pavement for the side slopes of the geotextile shall be poured in sections beginning at the bottom and ending at the top.
  7. Damage to the geotextile occurring during the placement of concrete pavement shall be repaired immediately at no additional expense to the Owner.
  8. All geotextile installation shall be completely covered at the end of each work day unless otherwise approved by the Engineer.
  9. The geotextile shall be properly weighted to avoid uplift due to wind.
- B. Field Seaming
1. The seams shall be overlapped a minimum of 8-in.



### **3.03 FIELD QUALITY CONTROL**

- A. Prior to placement of the pond liner or concrete slab(s), the geotextile installation and related work shall be inspected by the Engineer. All work in the system therein being inspected shall be complete, clean, and ready for use. All work shall meet the requirements as to line, grade, cleanliness, and workmanship, as determined by the Engineer.
- B. All discrepancies shall be noted and repaired at no additional expense. Final acceptance of the system shall be contingent upon the approval of the Engineer.

### **3.04 DISPOSAL OF WASTE MATERIAL**

- A. Upon completion of installation, dispose of all trash, waste material, and equipment used in connection with the performed work and shall leave the premises in a neat and acceptable condition.

## **PART 4 - MEASUREMENT**

### **4.01 METHOD OF MEASUREMENT**

- A. The area of geotextile shall be measured in square yards (SY) of geotextile installed in place, completed, and approved. No separate measurement for any other work shall be made for Work under this Section.

## **PART 5 - PAYMENT**

### **5.01 METHOD OF PAYMENT**

- A. Payment will be made at the contract unit price per SY; inclusive of all placement, seaming, and material necessary for seam overlap. These prices shall fully compensate the Contractor for furnishing all materials and for all preparation installation, labor, equipment, tools, and incidentals necessary to compete the item.

END OF SECTION

## SECTION 31\_05\_19.15

### GEOCOMPOSITE DRAINAGE NETS

#### PART 1 - GENERAL

##### 1.01 SCOPE OF WORK

- A. Furnish all labor, materials, equipment, and incidentals required and install geocomposite drainage net as shown on the Drawings and as specified herein.

##### 1.02 RELATED WORK

- A. Site Preparation is included in Section P-151.
- B. Excavation and Embankment are included in Section P-152.
- C. Trenching, Backfilling, and Compaction are included in Sections P-152 and D-701.
- D. Geotextile Fabric is included in section 31\_05\_19.14.
- E. Fiber Reinforced Polypropylene (RPP) Liner is included in Section 31\_05\_19.17.

##### 1.03 SUBMITTALS

- A. Submit to the Engineer the following information:
  - 1. Manufacturer's background information.
  - 2. Information on factory size, equipment, personnel, number of shifts per day, and production capacity per shift.
  - 3. List of material properties and samples of geocomposite drainage net with attached certified test results.
  - 4. Manufacturer's quality control program and manual including description of laboratory facilities.
  - 5. A list of 10 completed facilities where the geocomposite drainage net is used including:
    - a. Name and purpose of facility, its location, and date of installation.
    - b. Name of Owner, project manager, design engineer, and installer.
    - c. Geomembrane thickness and surface area.
    - d. Information on performance of the facility.
  - 6. Shop drawing, including:
    - a. Proposed panel layout showing the installation layout identifying field seams as well as any variance or additional details that deviate from the Drawings.
    - b. Details of overlap and seaming of the geocomposite drainage net, anchoring, connections, and other reconstruction details.
  - 7. Installation schedule.

8. A manual that specifically defines the quality control and quality assurance program during installation including manufacturer's installation instructions.
9. Copy of quality control certificates in conformance with paragraph 2.02 below.

#### **1.04 REFERENCE STANDARDS**

- A. American Society for Testing and Materials (ASTM).
  1. ASTM D1238 - Standard Test Method for Flow Rates of Thermoplastics by Extrusion Plastometer.
  2. ASTM D1505 - Standard Test Method for Density of Plastics by the Density Gradient Technique.
  3. ASTM D1603 - Standard Test Method for Carbon Black in Olefin Plastics.
  4. ASTM D1777 - Standard Test Method for Thickness of Textile Materials.
  5. ASTM D5034 - Test Method for Breaking Force and Elongation of Textile Fabrics.
  6. ASTM D3776 - Standard Test Method for Mass Per Unit Area (Weight) of Fabric.
  7. ASTM D4716 - Standard Test Method for Constant Head Hydraulic Transmissivity (in-Plane Flow) of Geotextiles and Geotextile Related Products.
- B. Where reference is made to one of the above standards, the revision in effect at the time of bid opening shall apply.

#### **1.05 QUALITY ASSURANCE**

- A. The quality control and quality assurance consists of conformance testing of the material delivered to the site and field quality control during installation.
- B. Conformance testing requirements are specified in paragraph 2.03 below. The purpose of conformance testing is to assure that the supplied material conforms to this Section and to the manufacturer's quality control certificates.
- C. Field quality control requirements are specified in paragraph 3.03 below. The purpose of field quality control procedures is to assure that the geocomposite drainage net material has been installed in accordance with this Section and the manufacturer's recommendations.

#### **1.06 DELIVERY, STORAGE, AND HANDLING**

- A. The geocomposite drainage net shall be shipped, stored, and handled in accordance with manufacturer's recommendations as specified herein.
- B. No mechanical equipment shall be driven directly on top of the geocomposite drainage net.

- C. The geocomposite drainage net shall be stored in such a way that it is protected from prolonged exposure to ultraviolet (UV) radiation and shall be elevated from the ground (a minimum of 3-in) to protect the geotextile from standing water and from intrusion of soil particles.

### 1.07 PROJECT/SITE REQUIREMENTS

- A. The underlying base grading shall be inspected and approved by the Engineer prior to installation of the geocomposite drainage nets.

### 1.08 MATERIAL WARRANTY

- A. The geocomposite drainage net manufacturer shall warrant the material, on a prorated basis, against manufacturing defect and material degradation for a period of 20 years from the date of installation. The manufacturer shall replace any material that fails from the above causes within the warranty period. The manufacturer shall furnish a written warranty covering the requirements of this paragraph.

### 1.09 GUARANTEE

- A. The Contractor shall guarantee the geocomposite drainage net against defects in installation and workmanship for the period of 2 years commencing with the date of Final Acceptance. The guarantee shall include the services of qualified service technicians and all materials required for the repairs at no expense to the Owner.

## PART 2 - PRODUCTS

### 2.01 GENERAL

- A. The use of a manufacturer's name and model or catalog number is for the purpose of establishing the standard of quality and general configuration.

### 2.02 MATERIALS

- A. Geocomposite drainage net shall be manufactured by heat bonding geotextiles to two sides of a drainage net core and shall conform to the following minimum properties:

| Properties                                    | Value  | Test Method            |
|---|--|------------------------|
| Transmissivity (gradient = 1.0 at 10,000 psf) | $0.10 \times 10^{-3} \text{ m}^2/\text{sec}$ | ASTM D4716             |
| Ply adhesion                                  | 1.0 lb/in                                    | ASTM D413 or ASTM F904 |

- B. Geocomposite drainage net shall contain UV inhibitors to prevent UV light degradation.

- C. Geocomposite drainage net core component shall be manufactured by extruding two sets of high-density polyethylene strands to form a three-dimensional structure to provide planar water flow and shall be manufactured from high density polyethylene containing not less than 97 percent base polymer and not less than 2 percent carbon black and shall conform to the following minimum properties:

| Properties                      | Value        | Test Method |
|---------------------------------|--------------|-------------|
| Density                         | 0.940 g/cc   | ASTM D1505  |
| Melt Index (max.) (condition E) | 1.0 g/10 min | ASTM D1238  |
| Carbon Black Content            | 2 percent    | ASTM D4218  |
| Thickness                       | 0.200-in     | ASTM D5199  |
| Mass Per Unit Area              | 0.162 psf    | ASTM D5261  |
| Tensile Strength                | 45 lb/in     | ASTM D5035  |

- D. Geotextile component shall be a nonwoven, needle-punched, staple fiber, polypropylene material consisting of continuous filaments or multifilament yarns formed into a stable network. The material shall be nonbiodegradable, nonreactive within a pH range of 3 to 11, resistant to UV light, and shall meet the following minimum average roll values:

| Properties          | Value                   | Test Method |
|---------------------|-------------------------|-------------|
| Fabric weight       | 10.0 oz/yd <sup>2</sup> | ASTM D5261  |
| Grab strength       | 260 lb                  | ASTM D4632  |
| Puncture resistance | 180 lb                  | ASTM D4833  |
| Water flow rate     | 85 gpm/ft <sup>2</sup>  | ASTM D4491  |
| AOS sieve size      | 100                     | ASTM D4751  |
| Max opening size    | 0.150 mm                |             |

- E. Geocomposite drainage net shall be manufactured by Serrot; Poly-Net; Gundle; Tensar; or an approved manufacturer meeting the above physical properties.

## 2.03 QUALITY CONTROL DOCUMENTATION

- A. Prior to installation commencement of any geocomposite drainage net material, provide to the Owner the following information certified by the manufacturer for the delivered geocomposite drainage net.
- Each roll delivered to the site shall have the following identification information:
    - Manufacturer's name.
    - Product identification.
    - Thickness.
    - Roll number.
    - Roll dimensions.

2. Quality control certificates, signed by the manufacturer's quality assurance manager. Each certificate shall have roll identification number, sampling procedures, frequency, and test results. At a minimum the following test results shall be provided every 50,000-ft<sup>2</sup> of manufactured geocomposite drainage net, and at least once for each lot, in accordance with test requirements specified in paragraph 2.04 below.
  - a. Density.
  - b. Resin Melt Index.
  - c. Thickness.
  - d. Carbon Black Content.
  - e. Mass per Unit Area.
  - f. Transmissivity.
  - g. Tensile Strength.

## 2.04 CONFORMANCE TESTING

- A. Conformance testing shall be performed by an independent Quality Assurance Laboratory (QAL) approved by the Owner. Engineer will obtain samples from the delivered material, mark the machine direction and identification number. Two samples shall be taken per 100,000-ft<sup>2</sup>, or two samples per lot, whichever results in the greater number of conformance tests. This sampling frequency may be increased as deemed necessary by the Engineer. The samples shall be taken across the entire roll width and shall not include the first 3-ft. The following conformance tests shall be conducted at the laboratory:
  1. Density (ASTM D1505).
  2. Carbon Black Content (ASTM D4318).
  3. Mass per Unit Area (ASTM D5261).
  4. Melt Index (ASTM D1238).
  5. Thickness (ASTM D5199).
  6. Transmissivity (ASTM D4716).
  7. Tensile Strength (ASTM D5035).
  8. Fabric Weight (ASTM D5261).
  9. Grab Strength (ASTM D4632).
  10. Puncture Resistance (ASTM D4833).
  11. Water Flow Rate (ASTM D4491).
  12. AOS Sieve Size (ASTM D4751).
- B. These conformance tests shall be performed in accordance with test requirements specified in paragraph 2.02 above.

- C. All conformance test results shall be reviewed by the Engineer and accepted or rejected, prior to the deployment of the geocomposite drainage net. All test results shall meet, or exceed, the property values listed in paragraph 2.02 above. In case of failing test results, the Contractor may request that another sample be retested by the QAL with manufacturer's technical representative present during the testing procedures. This retesting shall be paid for by the Contractor. The Contractor may also have the sample retested at two different laboratories approved by the Owner. If both laboratories report passing results, the material shall be accepted. If both laboratories do not report passing results, all material from the lot representing the failing sample will be considered out of specification and rejected. The manufacturer reserves the right to obtain additional samples from rolls immediately before and after the failing roll or as directed by the Engineer and have them tested by the QAL at his/her own expense. If these rolls pass, then only the failing roll will be rejected. If they fail, then the entire lot will be rejected.

## **PART 3 - EXECUTION**

### **3.01 PREPARATION**

- A. General:
1. Preparation of the underlying liner material shall be in accordance with Technical Specifications Section 31\_05\_19.17.
  2. The subgrade shall be inspected by the Engineer prior to installation of the geocomposite drainage net.

### **3.02 INSTALLATION**

- A. Panel Placement
1. Care shall be taken to keep the geocomposite drainage net clean and free from debris prior to installation. If the geocomposite drainage net is not clean, it should be washed prior to installation.
  2. The geocomposite drainage net shall be installed in such a manner as to ensure that it is not damaged in any way, and the following shall be complied with during installation:
    - a. Geocomposite drainage net shall be anchored into a trench as shown on the Drawings.
    - b. On slopes, the geocomposite drainage net shall be secured and rolled down the slope in such a manner as to continually keep the geocomposite drainage net sheet in tension. If necessary, the geocomposite drainage net shall be positioned by hand after being unrolled to minimize wrinkles.
    - c. In the presence of wind, all geocomposite drainage net shall be weighted with sandbags or by other means. Such sandbags shall be installed during placement and shall remain until replaced with cover material.

- d. Geocomposite drainage net shall not be welded to geomembrane.
  - e. Geocomposite drainage net shall only be cut using scissors or other cutting tools approved by the manufacturer. Care shall be taken not to leave tools on the geocomposite drainage net.
  - f. Necessary precautions shall be taken to prevent subgrade disturbance during placement of the geocomposite drainage net.
  - g. During placement of geocomposite drainage net care shall be taken not to entrap in the geocomposite drainage net dirt or excessive dust that could cause clogging of the drainage system and/or stones that could damage the adjacent geomembrane. If dirt or excessive dust is entrapped in the geocomposite drainage net, it should be hosed clean prior to placement of the next material on top of it. In this regard, care shall be taken in handling the sandbags, to prevent rupture or damage of the sandbag.
- B. Field Seams and Overlaps:
- 1. The following requirements shall be met during installation of the geocomposite drainage net:
    - a. Adjacent rolls shall be overlapped by at least 4-in.
    - b. Overlaps shall be secured by tying. Tying can be achieved by plastic fasteners or polymer braid approved by the Engineer. Tying devices shall be white or yellow for easy inspection. Metallic devices are not allowed.
    - c. Tying shall be every 5-ft along the slope, every 6-in in the anchor trench, and every 6-in along end-to-end seams on the base of the pond.
    - d. No horizontal seams shall be allowed on side slopes.
    - e. In the corners of the side slopes where overlaps between perpendicular geocomposite drainage net strips are required, an extra layer of geocomposite drainage net shall be unrolled along the slope, on top of the previously installed geocomposite drainage net from top to bottom of the slope.
    - f. When more than one layer of geocomposite drainage net is installed, joints shall be staggered.

### 3.03 FIELD QUALITY CONTROL

- A. Two duplicate project documentation files shall be maintained. One shall be maintained by the Contractor and the other by the Engineer. At the end of each workweek the files shall be updated and checked to assure that all copies of pertinent project information are included in each file. Submit daily copies of the documentation to the Engineer.



- B. Any holes or tears in the geocomposite drainage net shall be repaired by placing a patch extending 1-ft beyond the edges of the hole or tear. The patch shall be secured to the original geocomposite drainage net by placing ties every 6-in. Tying devices shall be as specified in paragraph 3.02B above. All repairs and patches shall be approved by the Engineer.
- C. Damage to the geocomposite drainage net occurring during the placement of the material overlying the geocomposite drainage net shall be repaired immediately at no additional expense to the Owner.

### **3.04 DISPOSAL OF WASTE MATERIAL**

- A. Upon completion of installation, dispose of all trash, waste material, and equipment used in connection with the performed work and shall leave the premises in a neat and acceptable condition.

## **PART 4 - MEASUREMENT**

### **4.01 METHOD OF MEASUREMENT**

- A. The area of geocomposite drainage net shall be measured in square yards (SY) of geocomposite drainage net installed in place, completed, and approved. No separate measurement for any other work shall be made for work under this Section.

## **PART 5 - PAYMENT**

### **5.01 METHOD OF PAYMENT**

- A. Payment will be made at the contract unit price per SY; inclusive of all placement, seaming, and any additional materials necessary to place in the anchor trench. These prices shall fully compensate the Contractor for furnishing all materials and for all preparation, installation, labor, equipment, tools, and incidentals necessary to complete the item.

END OF SECTION

## SECTION 31\_05\_19.17

### FIBER REINFORCED POLYPROPYLENE (RPP) LINERS

#### PART 1 - GENERAL

##### 1.01 DESCRIPTION

- A. Furnish all labor, materials, equipment, and incidentals required and install pond liner geomembrane as shown on the Drawings and as specified herein.

##### 1.02 DEFINITIONS

- A. Refer to ASTM D1600 for definition of abbreviated terms for plastics not otherwise defined in this Section.
  - 1. RPP: Fiber Reinforced Polypropylene.

##### 1.03 RELATED WORK

- A. Site Preparation is included in Section P-151.
- B. Trenching, Backfilling, and Compaction are included in Sections P-152 and D-701.
- C. Fill Materials are included in Section P-152.

##### 1.04 SUBMITTALS

- A. In addition to Product Data for geomembrane, and any seaming adhesive materials and penetration assembly, submit the following:
  - 1. Shop Drawings: Show fabrication and installation details for geomembrane liner. Show panel layout, seams, penetrations, perimeter anchorage, and methods of sealing to other construction. Differentiate between factory and field seams and joints.
  - 2. Samples for Verification: For each geomembrane, not less than one 12-in (300 mm) seam length of factory-bonded sheets and one 12-in (300-mm) seam length of field-bonded sheets.
  - 3. Installer Certificates: Signed by manufacturer certifying that installers comply with requirements.
  - 4. Manufacturer Certificates: Signed by manufacturers certifying that they comply with requirements.
  - 5. Qualification Data: For firms and persons specified in "Quality Assurance" Article to demonstrate their capabilities and experience. Include lists of completed projects with project names and addresses, names and addresses of architects and owners, and other information specified.

6. Material and Product Test Reports: Indicating materials, geomembrane, and seams comply with requirements, based on comprehensive testing of current product formulations and products.
7. Field Test Reports: Indicate and interpret test results for compliance with performance requirements.
8. Maintenance Data: For geomembrane system, provide maintenance manuals.
9. Warranties: Special warranties specified in this Section.

### 1.05 REFERENCE STANDARDS

- A. American Society for Testing Materials (ASTM):
  1. ASTM D413 - Standard Test Methods for Rubber Property - Adhesion to Flexible Substrate.
  2. ASTM D471 - Standard Test Method for Rubber Property - Effects of Liquids.
  3. ASTM D751 - Standard Test Methods for Coated Fabrics.
  4. ASTM D1204 - Standard Test Method for Linear Dimensional Changes of Nonrigid Thermoplastic Sheeting or Film at Elevated Temperature.
  5. ASTM D1600 - Standard Terminology for Abbreviated Terms Relating to Plastics.
  6. ASTM D2136 - Standard Test Methods for Coated Fabrics - Low Temperature Bend.
  7. ASTM D3083 - Standard Specification for Flexible Poly(Vinyl Chloride) Plastic Sheeting for Pond, Canal, and Reservoir Lining.
  8. ASTM D4437 - Standard Practice for Determining the Integrity of Field Seams Used in Joining Flexible Polymeric Sheet Geomembranes.
  9. ASTM D4833 - Standard Test Method for Index Puncture Resistance of Geotextiles, Geomembranes, and Related Products.
- B. National Sanitation Foundation (NSF):
  1. NSF Standard 54 - Flexible Membrane Liners.
- C. The latest version of all referenced standards, in effect at time of bid opening, shall apply.

### 1.06 INSTALLER QUALIFICATIONS

- A. Fabricator of products.
  1. Installer Qualifications: An experienced installer who employs workers trained and approved by geomembrane panel manufacturer to install manufacturer's products.
  2. Installer Qualifications: An experienced installer who has specialized in installing work similar in material, design, and extent to that indicated for this Project and who is acceptable to geomembrane panel manufacturer.

## **1.07 MANUFACTURER QUALIFICATIONS**

- A. A firm experienced in manufacturing geomembrane liner panels similar to those indicated for this Project and with a record of successful in-service performance.

## **1.08 SOURCE LIMITATIONS**

- A. Obtain geomembrane liner panels, accessories, and required seaming materials through one source from a single manufacturer.

## **1.09 PREINSTALLATION CONFERENCE**

- A. Conduct conference at Project site. Review methods and procedures related to product including, but not limited to, the following:
  - 1. Inspect and discuss condition of substrate and other preparatory work performed by other trades.
  - 2. Review structural load limitations.
  - 3. Review limitations on equipment and Installer's personnel.
  - 4. Review and finalize construction schedule and verify availability of materials, Installer's personnel, equipment, and facilities needed to make progress and avoid delays.
  - 5. Review required testing, inspecting, and certifying procedures.
  - 6. Review weather and forecasted weather conditions and procedures for unfavorable conditions.

## **1.10 WEATHER LIMITATIONS**

- A. Proceed with installation only when existing and forecasted weather conditions permit placement and seaming of geomembrane to be performed according to manufacturers' written instructions and warranty requirements. Do not place or seam geomembrane during conditions of precipitation, excessive atmospheric moisture, blowing dust, strong wind, or at temperatures outside manufacturers' recommended range.

## **1.11 WARRANTY**

- A. General Warranty: Special warranty specified in this Article shall not deprive Owner of other rights Owner may have under other provisions of the Contract Documents and shall be in addition to, and run concurrent with, other warranties made by Contractor under requirements of the Contract Documents.

- B. Special Warranty: Written warranty, signed by geomembrane manufacturer, liner manufacturer, and liner Installer agreeing to repair or replace geomembrane liner that fails in materials and workmanship or that deteriorates under conditions of normal weather within 1 year from date of Substantial Completion. Warranty does not include deterioration or failure of geomembrane liner due to exposure to harmful chemicals, gases or vapors, abnormal and severe weather phenomena, fire, earthquakes, floods, vandalism, or abuse by persons, animals, or equipment. Failures include, but are not limited to, leaks.
1. The Geomembrane Manufacturer shall confirm in writing, that the material to be furnished will be free of defects in materials and workmanship at the time of sale, and against deterioration due to the effects of ozone, ultraviolet or other normal weathering on a pro-rata basis for up to 10 years from the date of completed installation. The RPP Geomembrane Manufacturer shall furnish a sample warranty for review and approval prior to shipment.

## PART 2 - PRODUCTS

### 2.01 MANUFACTURERS

- A. Manufacturers: Subject to compliance with requirements, provide products by one of the following:
1. Colorado Lining International.
  2. Watersaver Company, Inc.

### 2.02 MATERIALS

- A. RPP Sheet
1. Virgin RPP, compounded for use in hydraulic structures; formed into uniform, flexible sheets; totally encapsulating 9 x 9x 1000D, polyester-fabric reinforcing scrim; and as follows:
    - a. Nominal Thickness: 60-mil (1.5-mm)-thick sheet per ASTM D751.
    - b. Hydrostatic Resistance: Not less than 350-psi (2,413-kPa) resistance per ASTM D751, Method A, Procedure 1.
    - c. Dimensional Stability, Reinforced Sheet: Not more than plus or minus 1percent per ASTM D1204.
    - d. Breaking Strength: Not less than 250 lbf (1.09 kN) per ASTM D751, Method A.
    - e. Tearing Resistance: Not less than 55 lbf (0.44 kN) per ASTM D751, Tongue Tear.
    - f. Puncture Resistance: Not less than 250 lbf (1.1 kN) per FTM 191AB, Method 5120.
    - g. Low-Temperature Flexibility: Pass, 1/8-in (3-mm) mandrel, 4 hours at minus 40 deg F, and per ASTM D2136.

- h. Ply Adhesion: Not less than 20 lbf (4.4 kN/m) of seam width, or film tearing bond, according to ASTM D413, Machine Method, as modified by NSF 54, Annex A.
  - B. Adhesives:
    - 1. Provide adhesive tape for bonding liner to structures as shown and specified as follows:
      - a. Non-hardening, general purpose butyl rubber extruded sealant that forms an immediate and permanent bond between applicable surfaces in above and below ground applications.
      - b. Permanently flexible, non-shrinking and water-resistant.
      - c. High surface adhesion and good ductility.
      - d. Ready to use cold-applied without field mixing or fabrication required.
      - e. 100 percent solid material with no asbestos, oil or solvents used in the manufacture of the product.
      - f. Operating Temperature Range: minus 35 deg F to 250 deg F (-37 deg C to 121 deg C).
- C. Penetration Assemblies:
  - 1. Provide manufacturer's standard factory-fabricated assemblies for sealing penetrations. Include joint sealant, recommended in writing by liner manufacturer, compatible with geomembrane and containment conditions and materials.
- D. Battens:
  - 1. Long-length strips of material indicated, size as shown on Drawings, predrilled or punched for anchors, and with anchors.
- E. Fabricate geomembrane liner panels from sheets in sizes as large as possible with factory-sealed seams, consistent with limitations of weight and installation procedures. Minimize field seaming.
- F. Source Quality Control:
  - 1. Test for bonded seam strength and peel adhesion every 3,000-ft (915 m) or once per panel, whichever is more frequent, per NSF 54, Table 14.
    - a. RPP Liner: Test and inspect factory seams for peel adhesion not less than 20 lbf/in. (3.5 kN/m) of seam width, according to ASTM D413, as modified by NSF 54, Annex A, and for bonded seam strength not less than 200 lbf/in. (35 kN/m) of seam width according to ASTM D751, as modified by NSF 54, Annex A.

## PART 3 - EXECUTION

### 3.01 FACTORY FABRICATION

- A. The Fabricator shall be experienced in the fabrication of large panels of scrim-reinforced geomembranes. Project experience shall include a minimum of 5,000,000-ft<sup>2</sup> of large fabricated geomembrane panels.
- B. Panel Fabrication:
1. All geomembrane stock shall be inspected for defects, damage during shipping, etc. prior to panel fabrication. Damaged material shall either be repaired or discarded, depending on the extent of the damage. Large panels shall be fabricated to minimize field seaming.
  2. Factory seams shall have a minimum scrim to scrim overlap of 1-1/4-in. The thermal fusion bond shall extend to the top edge of the sheet so that no loose edges are present on the top side of the panel.
- C. Inspection of Factory Seams:
1. All panels and seams shall be visually inspected for damage and/or defects. Damaged or defective seams, exposed edge scrim, etc. will not be accepted. All exposed scrim edges shall be sealed with an approved RPP extrusion weld or capped with a strip of RPP. Appropriate repairs shall be made prior to shipment to the field.
- D. Testing of Factory Seams:
1. Samples shall be obtained during fabrication from each factory seam welding unit at the beginning of each work shift and every four hours of fabrication thereafter for testing of seam strength and peel adhesion in accordance with ASTM D751 as modified in Annex A of ANSI/NSF 54 and ASTM D413 as modified in Annex A of ANSI/NSF 54, respectively. Samples shall not interfere with or require patching of panels to be installed. A Sample Log shall be maintained indicating date, time, panel number, and test results and the Fabricator shall furnish the log to the Owner or Engineer upon request.
- E. Certification and Test Reports:
1. Prior to installation of factory fabricated panel in the field, the Fabricator shall provide the Engineer with written certification that the material meets all requirements of paragraph 2.02 and that the factory seams were inspected and tested in accordance with paragraph 3.01.

- F. Panel Packaging and Storage:
  - 1. Each fabricated panel shall be packaged in a manner to prevent damage during shipping. Each panel, and its packaging container, shall be prominently marked, identifying proper field placement and direction of unrolling and/or unfolding. Panels shipped to the construction site shall remain packaged and shall be stored in a dry area, protected from direct sunlight, where possible. Pallets containing packaging shall not be stacked.

### 3.02 SUBGRADE PREPARATION

- A. Subgrade shall be firm, clean, dry, and smooth graded. All surfaces must be free from sharp projections, angular rocks, rubble, roots, vegetation, debris, voids, protrusions, and groundwater; must comply with requirements for soil compaction and smooth grading; and must be free from other conditions affecting geomembrane performance. Examine anchor trench excavation for proper substrate conditions and for correct location and configuration.
- B. Immediately prior to the installation of the geomembrane, a complete and detailed inspection of the embankments shall be performed by the DIA Project Manager, Contractor, and the Geomembrane Installer to determine acceptance of the finished subgrade and elevations. Any erosion or other damage to the base material that has occurred since smooth grading was completed shall be corrected by the Contractor. Proceed with geomembrane installation only after unsatisfactory conditions have been corrected.
- C. Provide temporary ballast that does not damage geomembrane liner or substrate, to prevent uplift of liner in areas with prevailing winds, until edges are permanently secured.
- D. Prepare surfaces of construction penetrating through liner according to liner manufacturer's written instructions.

### 3.03 GEOMEMBRANE INSTALLATION

- A. Place geomembrane liner over prepared surfaces to ensure minimum handling. Install according to Shop Drawings and to comply with liner manufacturer's written instructions. In areas with prevailing winds, begin placing liner at Project's upwind direction and proceed downwind. Install liner in a relaxed condition, free from stress and tension. Fit closely and seal around inlets, outlets, and other projections through geomembrane liner. Only panels that can be anchored and seamed together in the same day shall be unpackaged and placed into position. Permanently secure edges in anchor trenches and use temporary ballasts to secure unanchored liner edges before termination of work for the day.



- B. Protect installed geomembrane liner according to liner manufacturer's written instructions. Materials, equipment, or other items shall not be dragged across the surface of the RPP liner or be allowed to slide down on the liner. All parties walking or working on the RPP lining material shall wear soft-sole shoes. Repair or replace areas of liner damaged by scuffing, punctures, traffic, rough subgrade, or other unacceptable conditions.
- C. Field Seams: Comply with liner manufacturer's written instructions for manufacturer's standard seaming method and procedures. Form lapped seams by lapping edges of panels 2- to 4-in (50- to 100-mm), unless instructions require a larger overlap. Wipe contact surfaces clean and free of dirt, dust, moisture, and other foreign materials. Proceed with seaming at required temperatures for materials and ambient conditions. Single seam welds of a specified width shall be used to continuously bond RPP sheets together as instructed by the liner manufacturer. Patch wrinkles and fishmouths. Fishmouths shall be split out from the seam an adequate distance to dissipate them, lapped, seamed, and patched. Seal or fuse free seam edges as instructed.
- D. Gas vents. Provide gas vents at upper edges of membrane liner. Construct gas vent flaps to prevent water from entering vent due to wave action. Space vents 25-ft on center around perimeter of lagoons.
- E. Liner Repairs: Repair tears, punctures, and other imperfections in liner and field seams using patches of liner material, and bonding methods according to liner manufacturer's written instructions. Roll to remove wrinkles. If reinforced patches are used, apply by extrusion welding.
- F. Field Quality Control:
1. Nondestructive Testing: Visually inspect all seams and patches. Comply with ASTM D4437 for Air Lance Test, Vacuum Box Testing, or with GRI Test Method GM6, as applicable to geomembrane and seam construction. Maintain log of testing location, date, time, item tested (patch, seam, etc.), and test results. Individually number and date occurrences and details of leak and remedial action. Repair leaking seams and patches.
  2. Destructive Testing: Destructive test seams shall be made by each seaming crew at the beginning of the seaming process and every 4 hours thereafter, or every time equipment is changed. Test seams are to be made of the same material as the liner, provided separately for the purpose of testing and not cut from the installed panels. The completed field seam for testing shall measure not less than 14-in in width by 24-in in length. A Test Log shall be maintained indicating seaming crew personnel, date, time, panel number, seam location, and test results. Seam samples shall be tested for seam strength and peel adhesion in accordance with ASTM D751 as modified in Annex A of ANSI/NSF 54 and ASTM D413 as modified in Annex A of ANSI/NSF 54, respectively.

- G. Before initial filling of pond, inspect seams and patched areas to ensure tight, continuously bonded installation. All field seams shall be checked using an air lance nozzle test method (per ASTM D4437) directed on the upper edge and surface to detect any loose edges or ripples indicating poorly bonded seams. Repair damaged membrane and seams and reinspect repaired work. All exposed reinforcing scrim edges shall be sealed with an approved extrusion weld or capped with a strip of polypropylene.

### **3.04 REPAIR MATERIALS AND INSTRUCTION**

- A. Provide Engineer with at least 100-ft<sup>2</sup> of reinforced liner material for making repairs after the project is complete. Provide an extrusion welder or other appropriate equipment, or both, required to effectively make repairs to the liner material after the project is complete.
- B. Instruct Engineer and Owner's staff on the recommended techniques for repairing holes or rips in the liner. Provide written directions on how to make a repair.
- C. Instruct Engineer and Owner's staff on the recommended techniques for cleaning and maintaining the liner. Provide written directions for cleaning and maintenance.

## **PART 4 - MEASUREMENT**

### **4.01 METHOD OF MEASUREMENT**

- A. The area of liner shall be measured in square yards (SY) of liner installed in place, completed, and approved. No separate measurement for any other work shall be made for Work under this Section.

## **PART 5 - PAYMENT**

### **5.01 METHOD OF PAYMENT**

- A. Payment will be made at the contract unit price per SY; inclusive of all placement, seaming, and material necessary for seam overlap. These prices shall fully compensate the Contractor for furnishing all materials and for all preparation installation, labor, equipment, tools, and incidentals necessary to compete the item.

END OF SECTION



# DIVISION 35 – WATERWAY AND MARINE CONSTRUCTION

Pond 001 Expansion

Construction Contract No. 201737313

## Denver International Airport

Denver, Colorado

Sponsored By:

City & County of Denver Department of Aviation

Issued for Construction  
November 21, 2017



## SECTION 35\_20\_16.02

### SLIDE GATES

#### PART 1 GENERAL

##### 1.01 SUMMARY

- A. Section includes: Slide gates and accessories.
- B. Related sections:
  - 1. The Contract Documents are complementary; what is called for by one is as binding as if called for by all.
  - 2. It is the CONTRACTOR's responsibility for scheduling and coordinating the Work of subcontractors, suppliers, and other individuals or entities performing or furnishing any of CONTRACTOR's Work.
  - 3. The following Sections are related to the Work described in this Section. This list of Related Sections is provided for convenience only and is not intended to excuse or otherwise diminish the duty of the CONTRACTOR to see that the completed Work complies accurately with the Contract Documents.
    - a. Section 40\_05\_57.99 - Electrohydraulic Operator.
    - b. Section 40\_80\_01 - Testing, Calibration, and Commissioning.

##### 1.02 REFERENCES

- A. American Water Works Association (AWWA):
  - 1. C561 - Fabricated Stainless Steel Slide Gates.
- B. ASTM International (ASTM):
  - 1. A276 - Standard Specification for Stainless Steel Bars and Shapes.
  - 2. B584 - Standard Specifications for Copper Alloy Sand Castings for General Application.
  - 3. D1248 - Standard Specification for Polyurethane Plastics Extrusion Materials for Wire and Cable.
  - 4. D2000 - Standard Classification for Rubber Products in Automotive Applications.
  - 5. D4020 - Standard Specification for Ultra-High Molecular-Weight Polyethylene Molding and Extrusion Materials.
  - 6. F 593 - Standard Specification for Stainless Steel Bolts, Hex Cap Screws, and Studs.
  - 7. F 594 - Standard Specification for Stainless Steel Nuts.

##### 1.03 DEFINITIONS

- A. Slenderness ratio ( $l/r$ ): The largest ratio obtained by dividing the unsupported length of the stem by the radius of gyration of the stem cross section.

- B. Design head: Depth from surface of water to centerline of gate. Use value specified in the gate schedule.
- C. Seating head: Pressure applied to gate slide from weight of water column above gate centerline that forces gate slide into seat.
- D. Unseating head: Pressure applied to gate slide from weight of water column above gate centerline that forces gate slide away from seat.
- E. Substantially similar:
  - 1. Similar in size, design head, and service.
  - 2. Utilizes the proposed design for critical components including guides and seals.

#### 1.04 DESIGN REQUIREMENTS

- A. Except as modified or supplemented as specified in this Section, all gates and operators shall conform to the requirements of AWWA C561, latest edition.
- B. Gate components:
  - 1. Frames:
    - a. Design for the design head scheduled with a minimum safety factor of 5 with regard to ultimate tensile, compressive, and shear strength.
    - b. Self-contained gates: Where frames extend above the operating floor, design to be self-supporting so that no further reinforcing or support is required.
    - c. Anchors for frames shall be located at 5-inches from edge of concrete opening. Coordinate anchor sizes and embedment depths with rebar placement at opening.
  - 2. Stem: Select stem diameter, stem guide quantity and stem guide spacing based on following criteria:
    - a. Slenderness ratio ( $l/r$ ): Shall not exceed 200.
    - b. Maximum diameter: Provide stem guides at a spacing to maintain stem diameter of 2 inches or less.
    - c. Tensile strength: Suitable to withstand the force generated by the operator with the application of a 200 pound force applied to the crank or handwheel or a 250 foot-pound torque applied to the wrench nut.
    - d. Compressive strength:
      - 1) Suitable to withstand buckling due to the force generated by the operator with the application of an 80 pound force applied to the crank or handwheel or a 100 foot-pound torque applied to the wrench nut.
      - 2) Determine buckling load using Euler Column formula in accordance with AWWA C 561, where  $C = 2$ .
    - e. Design force for power actuators:
      - 1) Hydraulic cylinder operators: 1.25 times the output thrust at maximum hydraulic fluid operating pressure.

- 2) Electric motor operators: 1.25 times the output thrust in the stalled-motor condition.
- f. Gates having widths greater than 2 times the height: Provide with 2 lifting mechanisms connected by a tandem shaft.
3. Thrust nut: Suitable to withstand thrust developed by operator with the application of a 40 pound force on the crank or handwheel with safety factor of 5. Base design on ultimate strength of material used.
4. Yokes for self-contained gates:
  - a. Design yoke using design loading criteria for stem with safety factor of 5 based on the ultimate strength of the material used.
  - b. Maximum deflection at design load: Not to exceed 1/360th of the span.
5. Slide:
  - a. Deflection shall be less than or equal to 1/1000 of the span of the gate or 1/16 inch, whichever is less, when under the design head.
  - b. Design for the maximum design head specified with a minimum safety factor of 5 with regard to ultimate tensile, compressive, and shear strength.

### 1.05 PERFORMANCE REQUIREMENTS

- A. Leakage shall comply with allowable limits set forth in AWWA C561.

### 1.06 SUBMITTALS

- A. Product data:
  1. For each item of equipment:
  2. Design features.
  3. Load capacities.
  4. Efficiency ratings.
  5. Material designations by UNS alloy number or ASTM Specification and Grade.
  6. Data needed to verify compliance with the Specifications.
  7. Catalog data.
  8. Nameplate data.
  9. Clearly mark submittal information to show specific items, materials, and accessories or options being furnished.
- B. Calculations:
  1. Gate opening and closing thrust forces that will be transmitted to the support structure with operator at extreme positions and load.
  2. Torque required to open and close the gate, including maximum torque at any point along gate travel. Indicate thrust valve and stem factor.
  3. Breakaway torque from seat. Indicate thrust valve and stem factor.
  4. Perform calculations and determine number, size, type, strength, and location of anchor bolts or other connections for anchorage to concrete.
  5. Calculations shall be signed and stamped by a licensed engineer.
- C. Vendor operation and maintenance manuals.



- D. Commissioning submittals:
  - 1. Provide Manufacturer's Certificate of Installation and Functionality Compliance per form included at the end of this specification.
  
- E. Shop drawings:
  - 1. Layout and installation drawings for each gate size and type.
  - 2. For coordination purposes, gate manufacturer shall supply calculations verifying the suitability of the selected motorized operator for the application. For each gate include:
    - a. Open/close speed as specified in Section 40\_05\_57.99.
    - b. The maximum torque required for operation of the gate (including breakaway from seat) with a safety factor of 1.4.
    - c. The torque supplied by the motorized operator scheduled in Section 40\_05\_57.99 for the operating speed specified in Section 40\_05\_57.99.
    - d. The thrust output capacity of the motorized operator with the furnished motor.
  - 3. Submit calculations and design data substantiating conformance with the Drawings and Specifications.
  - 4. Gate opening and closing thrust forces that will be transmitted to the support structure with operator at extreme positions and load.
  - 5. Torque required to open and close the gate, including maximum torque at any point along gate travel. Indicate thrust valve and stem factor.
  - 6. Breakaway torque from seat. Indicate thrust valve and stem factor.

## 1.07 QUALITY ASSURANCE

- A. Manufacturer qualifications:
  - 1. Experience in production of substantially similar equipment during the 5 years prior to issuance of this contract, and able to submit evidence of satisfactory operation in at least 5 different installations.
  - 2. Manufacturer's shop welds, welding procedures, and welders: Qualified and certified in accordance with the requirements of AWS A5.10 and AWS D1.2.
  - 3. Assembled gates: Shop inspected and adjusted before shipping.

## 1.08 WARRANTY

- A. Written warranty issued by item's manufacturer.
  
- B. Project-specific information, properly executed by product manufacturer, and expressly states that its provisions are for the benefit of the Owner.
  
- C. Covers all costs associated with the correction of the defect, including but not limited to removal of defective parts, new parts, labor, and shipping.
  - 1. When correcting warranted Work that has failed, remove and replace other Work that had been damaged as a result of such failure or that must be removed and replaced to provide access for correction of warranted Work.

- D. Provides a timely response to correct the defect.
  - 1. Manufacturer shall provide, in a timely fashion, temporary equipment as necessary to replace warranted items requiring repair or replacement, when warranted items are in use and are critical to the treatment process, as defined by Owner.
  - 2. In the case that Owner has to provide temporary equipment to replace function of warranted item requiring repair or replacement, manufacturer shall reimburse Owner for such costs associated with the temporary equipment.
- E. Warranty commence running on the date of substantial completion.
  - 1. For items of Work for which acceptance is delayed beyond Date of Substantial Completion, submit warranty within 10 calendar days after acceptance, listing date of acceptance as beginning of warranty period.
- F. Duration of Warranty: 1 year.

## **PART 2 PRODUCTS**

### **2.01 MANUFACTURERS**

- A. One of the following or equal:
- B. Manufacturers: One of the following or equal.
  - 1. Golden Harvest, Series GH-100.
  - 2. H. Fontaine, Series 20.
  - 3. Waterman Industries, Sentinel, III.
  - 4. Rodney Hunt Company, Series 600.
  - 5. Whipps, Series 900.
- C. Operators and anchor bolts: Provided by slide gate manufacturer.

### **2.02 MATERIALS**

- A. All materials shall be compatible with the following maximum chemical concentrations:
  - 1. Propylene glycon: maximum 50 percent solution by weight.
  - 2. Potassium acetate: maximum 10 percent solution by weight.
  - 3. Sodium formate: maximum 10 percent solution by weight.
  - 4. Potassium formate: maximum 10 percent solution by weight.
  - 5. Jet "A" (aviation fuel): maximum 1 percent solution by weight.
  - 6. Unleaded gasoline: maximum 1 percent solution by weight.
  - 7. Diesel fuel: maximum 1 percent solution by weight.
- B. Stainless steel: ASTM A276, Type 316:
  - 1. Components or structural shapes which are welded: ASTM A276, Type 316L.
  - 2. All wetted and unwetted parts including all fasteners and hardware, except as specified in this Section, shall be stainless steel.

- C. Ultra-high molecular weight polyethylene: ASTM D1248 and D4020.
- D. Manganese bronze: ASTM B584, UNS Number C86500 or Alloy 432.
- E. Silicon bronze: ASTM B584 UNS Number C87300.
- F. Neoprene: Not allowed. Provide Buna-N, ASTM D 2000.
- G. Ultra-high molecular weight polyethylene, ASTM D 1248.

## 2.03 COMPONENTS

- A. Slide:
  - 1. Type 316L stainless steel.
  - 2. Rectangular or square.
  - 3. Fabricated with a flat plate reinforced with formed plates or structural members.
- B. Frame:
  - 1. Construct gate frame of Type 316L stainless steel structural members or formed plate welded to form a rigid 1-piece frame.
  - 2. Mounting: As scheduled on the Drawings.
  - 3. Adjustable ultra-high molecular weight polyethylene pressure pads.
  - 4. Flush bottom type unless otherwise scheduled on the Drawings.
  - 5. Allow replacement of top, side, and bottom seals without removing the gate frame from concrete or wall thimble.
  - 6. Machine surfaces matching with thimble. Provide seal between gate frame and thimble that will meet leakage performance requirements.
  - 7. Embedded gates: Extend frame to provide access to pressure pad adjusting screws (For seal design alternatives A and B only).
- C. Yoke for self-contained gates:
  - 1. Type 316L stainless steel.
  - 2. Extend guides and frame so that bottom of yoke is at least 12 inches above top of slide at full open position.
  - 3. Bolt or weld to frame.
  - 4. Provide mounting plate on top of yoke to mount operator.
  - 5. Design yoke to allow removal of gate slide.
- D. Guides:
  - 1. Type 316L stainless steel with ultra-high molecular weight polyethylene insert in contact with gate.
  - 2. Minimum face width of 1 inch.
  - 3. Length: To support the slide fully in the open position.
  - 4. Anchor bolts shall not pass through the guides and seals.
- E. Seals:
  - 1. Designed to achieve the specified leakage requirements.

2. Sealing and sliding surfaces shall provide a low coefficient of friction with the surface of the slide.
  3. Field replaceable without removing gate from concrete or wall thimble.
  4. Anchor bolts shall not pass through the guides and seals.
  5. J-bulb seals are not acceptable.
  6. Minimum seating surface width: 3/4 inch in contact with slide.
  7. Bottom seal:
    - a. Resilient Buna-N, minimum durometer of 45.
    - b. Attached to the bottom of the slide or embedded in gate frame invert.
  8. Side and top seals:
    - a. Provide one of the seal design alternatives listed below.
    - b. Seal design alternative A:
      - 1) UHMWPE fixed sealing surfaces that surround the clear opening.
      - 2) Held in place in the guide with Type 316 stainless steel fasteners.
      - 3) Seal compression shall be maintained by UHMWPE field adjustable pressure pads mounted to the slide with Type 316 stainless steel fasteners.
    - c. Seal design alternative B:
      - 1) Buna-N crown seal with UHMWPE bearing bars.
      - 2) Attached to the slide with Type 316 stainless steel fasteners.
      - 3) Crown seal shall be actuated by water pressure in either the seating or unseating direction.
      - 4) Primary contact with the slide shall be through the UHMWPE bearing bar. The neoprene shall not be solely relied upon for the contact seal.
      - 5) Seal compression may be maintained by UHMWPE field adjustable pressure pads mounted to the guide with Type 316 stainless steel fasteners.
    - d. Seal design alternative C:
      - 1) UHMWPE self-adjusting type seals: Utilize a continuous compression cord to ensure contact between the seals and the slide.
      - 2) Side seals:
        - a) Attach to frame using one of the following approaches.
          - (1) Held in place between the front and back angles of the guide with Type 316 stainless steel bolts passing through the guide and seal along the length of the guide.
          - (2) Held in place between front and back of a formed, one piece, rigid channel guide. Attach seals to frame using Type 316 stainless steel bolts.
        - b) Design and installation shall provide access to and removal of the bolt to allow removal of the side seal without removing the gate from the concrete.
      - 3) Top Seal: UHMWPE self-adjusting type seal with double compression cord.
- F. Stem:
1. Type 316 stainless steel.
  2. Machine cut or rolled threads.

3. Stem couplings:
    - a. Silicon bronze or Type 316 stainless steel.
    - b. Threaded and keyed to stem or threaded and bolted to stem.
  4. Stem guides:
    - a. Type 316 stainless steel.
    - b. Split collar.
    - c. Adjustable in 2 directions.
    - d. Ultra-high molecular weight polyethylene bushing.
  5. Provide manganese bronze stop collar on stem above actuator.
  6. Drill and connect stem to slide structural sections with Type 316 stainless steel bolts.
  7. Minimum Stem Diameter: 1-1/2 inch.
  8. Coordinate the selection of the gate stem configuration with the gate operator and operating speed.
    - a. The selected gate stem configuration shall provide the most efficient combination of stem diameter/pitch/lead and keep the operating temperature at the stem nut to a minimum during operation.
    - b. If the proposed gate stem configuration would result in any deviation from the operating rise rate specified in Section 40\_05\_57.99, submit proposed deviation for approval by the Engineer.
- G. Operating nut:
1. Locate at operator level.
  2. Material: Manganese bronze.
- H. Gate operators: As specified in Section 40\_05\_57.99.
- I. Bolts, nuts, and fittings: Type 316 stainless steel.
- J. Anchor bolts:
1. Type 316 stainless steel.

## 2.04 FINISHES

- A. Stainless steel:
1. Shot blast gates after fabrication to remove weld splatter and to polish scratches.
  2. Clean the entire surface to produce an even color and sheen.

## 2.05 FABRICATION

- A. Shop assembly:
1. Gates shall be factory assembled, adjusted, and tested.
  2. Mount all accessories and appurtenances including, but not limited to, motor operators and limit switches so that the complete system may be tested at the factory.

## **PART 3 EXECUTION**

### **3.01 INSTALLATION**

- A. Mount thimbles and gates plumb in both vertical planes and level in horizontal plane.
- B. Coat seating surfaces between frame and wall thimble with a waterproof plastic compound or provide Buna-N gasket prior to tightening frame studs.
- C. Adjust wedges or other parts of the gate to the point where it will not be possible to insert a 0.004 inch feeler gauge between the gate slide and the gate frame at any point.
  - 1. Securely lock wedges into position after adjustment.
- D. Adjust limit switches in electrohydraulic operators in accordance with manufacturer's instructions.
- E. Face mounted gates:
  - 1. Where wall thimbles are not provided, mount gate to wall with anchor bolts and provide a 1-inch grout pad in accordance with manufacturer's recommendations.
- F. Embedded gates:
  - 1. Provide blockouts in sidewalls and channel bottom for installation of gates.
  - 2. After gate placement, adjustment, and alignment in accordance with manufacturer's recommendations, grout frame with non-shrink grout.

### **3.02 COMMISSIONING**

- A. Manufacturer services:
  - 1. Provide certificates:
    - a. Manufacturer's Certificate of Installation and Functionality Compliance.
  - 2. Manufacturer's Representative onsite requirements:
    - a. Installation: 1 trip, 1 day minimum.
    - b. Functional Testing: 1 trip, 1 day minimum.
  - 3. Training:
    - a. Maintenance: 2 hours per session, 1 session.
    - b. Operation: 2 hours per session, 1 sessions.
  - 4. Process Operational Period:
- B. Functional testing:
  - 1. Equipment:
    - a. Test witnessing: Non-Witnessed.
    - b. Leakage tests:
      - 1) Conduct in accordance with AWWA C 561. Comply with specified allowable leakage limits

- 2) After gate installation and checking, run gates through at least 2 full cycles from the closed position to full open position and back to the closed position.

### **3.03 SCHEDULE**

- A. The Slide Gate Schedule is indicated on the Drawings. The Slide Gate Schedule is not a take-off list. Contractor shall provide additional gates per specifications and as indicated on the Drawings.

## **PART 4 MEASUREMENT**

### **4.01 METHOD OF MEASUREMENT**

- A. No separate measurement shall be made for work under this Section.

## **PART 5 PAYMENT**

### **5.01 METHOD OF PAYMENT**

- A. No separate payment will be made for work under this Section. The cost of the work described in this Section shall be included in the applicable lump sum bid item.

END OF SECTION

**MANUFACTURER'S CERTIFICATE OF  
INSTALLATION AND FUNCTIONALITY COMPLIANCE**

OWNER \_\_\_\_\_ EQPT/SYSTEM \_\_\_\_\_  
PROJECT NAME \_\_\_\_\_ EQPT TAG NO. \_\_\_\_\_  
PROJECT NO. \_\_\_\_\_ EQPT SERIAL NO. \_\_\_\_\_  
SPECIFICATION NO. \_\_\_\_\_  
SPECIFICATION TITLE \_\_\_\_\_

I hereby certify that the above-referenced equipment/system has been: (Check Applicable)

- Installed in accordance with manufacturer's recommendations.
- Inspected, checked, and adjusted.
- Serviced with proper initial lubricants.
- Electrical/instrumentation and mechanical connections meet quality and safety standards.
- All applicable safety equipment has been properly installed.
- Functionally tested.
- System has been performance tested, and meets or exceeds specified performance requirements.

**NOTES:**

Attach test results with collected data and test report.

Attach written certification report prepared by and signed by the electrical and/or instrumentation subcontractor.

Comments: \_\_\_\_\_  
\_\_\_\_\_

I, the undersigned manufacturer's representative, hereby certify that I am (i) a duly authorized representative of the manufacturer, (ii) empowered by the manufacturer to inspect, approve, and operate this equipment/system, and (iii) authorized to make recommendations required to ensure that the equipment/system furnished by the manufacturer is complete and operational, except as may be otherwise indicated herein. I further certify that all information contained herein is true and accurate.

Date: \_\_\_\_\_, 20 \_\_\_\_\_

Manufacturer: \_\_\_\_\_

Manufacturer's Authorized Representative Name (*print*): \_\_\_\_\_

By Manufacturer's Authorized Representative: \_\_\_\_\_

(Authorized Signature)





# DIVISION 40 – PROCESS INTEGRATION

Pond 001 Expansion

Construction Contract No. 201737313

## Denver International Airport Denver, Colorado

Sponsored By:

City & County of Denver Department of Aviation

Issued for Construction  
November 21, 2017



## SECTION 40\_05\_57.99

### ELECTROHYDRAULIC ACTUATOR

#### PART 1 GENERAL

##### 1.01 SUMMARY

- A. Section includes:
1. Complete electrohydraulic actuator system to operate the equipment specified.
- B. Actuator requirements
1. As specified in Appendix A. System Description for the existing Pond 001 SUBA-II Actuator.
  2. Single self-contained unit, requiring only electrical connections.
  3. Completely factory wired, assembled and tested.
  4. Size operating rod and any required operating stem to safely withstand 1.25 times the actuator output at maximum system pressure.
  5. Size operating rod and any required operating stem so that  $L/r$  is less than 200; where "L" is the unsupported length and "r" is the radius of gyration.
  6. Material:
    - a. Hard chrome plated.
    - b. Any additional stem required: Stainless steel.
    - c. Hydraulic tubing: 300 series stainless steel with O-ring face seal,
    - d. Sil-brazed fittings: In accordance with SAE J1453.
  7. Electrical connections:
    - a. Make within conduit enclosures or junction boxes.
    - b. Properly labeled.
    - c. No live connections shall be exposed when the unit cover is removed.
    - d. If analog signal wiring is required, it should be shielded and separated from the control and power wiring.
  8. Actuator Cover
    - a. Weather-Tight Cover:
      - 1) Design to protect the actuator from windblown rain, splashing water, or hose-directed water.
    - b. Material: Steel.
  9. Nominal Speed:
    - a. 12"/min.: The actuator shall extend and retract at a nominal speed of 12 inches per minute.
  10. No power failure operation is required.
  11. Actuator environment:
    - a. Non-Hazardous.
    - b. Electrical components rated at NEMA 12 or better.
  12. Electrical Control Enclosure:
    - a. NEMA 4X rated.

- b. Separate electrical enclosure.
  - c. Material: Corrosion resistant.
  - d. Components:
    - 1) Mount on exterior of enclosure.
    - 2) NEMA 4X rated.
13. Local/ Remote Extend/Retract Controls:
- 1) Provide manually activated pushbuttons on the control enclosure to do the following:
    - a) Extend.
    - b) Retract.
    - c) Position the actuator.
  - 2) Provide remote activated system to do the following:
    - a) Extend.
    - b) Retract.
    - c) Position the actuator.
14. Position Indication:
- a. Provide end of travel indicating lights mounted on the control enclosure using proximity switches integrally mounted in the actuator.
15. Main electrical power source:
- a. 480 V, 3 Phase.
  - b. Provide disconnecting means within the control panel
  - c. Provide surge protection on the 480V, 3 phase line
16. Communication fiber optic multi-mode patch panel.
17. Testing:
- a. Shop test actuator in all modes of operation.
  - b. Verify motor operating amps and voltage.
  - c. Verify actuator operating speed and stroke.
  - d. Verify extension and retraction thrust adjustments.
18. Painting:
- a. First coat:
    - 1) Coat actuator with one coat of medium gray high-solids epoxy.
    - 2) Thickness: 5 mils.
  - b. Final coat:
    - 1) Coat actuator with one coat of medium gray aliphatic polyurethane.
    - 2) Thickness: 2 mils.
19. Controls:
- a. PLC: CompactLogix with Ethernet/IP communications:
  - b. Media Converter/Switch: Provide a media conversion device to convert from Ethernet/IP copper to 50 micron, Multimode Fiber Optic.
  - c. Provide Data tables of all PLC registers for coordination with owners existing PLC located in the pump station.

## **PART 2 PRODUCTS**

### **2.01 MANUFACTURER**

- A. The following or equal:
  - 1. Rodney Hunt Company, SCUBA unit.

## **PART 3 EXECUTION**

Not Used.

## **PART 4 MEASUREMENT**

### **4.01 METHOD OF MEASUREMENT**

- A. No separate measurement shall be made for work under this Section.

## **PART 5 PAYMENT**

### **5.01 METHOD OF PAYMENT**

- A. No separate payment will be made for work under this Section. The cost of the work described in this Section shall be included in the applicable lump sum bid item.

END OF SECTION



**SECTION 40\_05\_57.99**

**ELECTROHYDRAULIC ACTUATOR**

**ATTACHMENT A**





## *SYSTEM DESCRIPTION*

### **SCUBA-II Actuator for Two Existing Pond 1 Sluice Gates**

**Denver International Airport, Pond System Upgrades  
Runway 17R-35L  
Denver, CO**

**Rodney Hunt Shop Order #5122190-5  
Orange, Massachusetts**

## **OVERVIEW**

This system description is for the SCUBA-II electro-hydraulic actuator, cylinders, controls, and a portable gas-engine powered pumping unit for the above referenced project. The electro-hydraulic actuator is furnished for slab-mounting to operate the two existing 96" x 96" cast iron sluice gates. Two cylinders are provided with wall brackets and thrust nuts for installation in the gate chamber.

Opened and closed limit switches are mounted integrally to the cap and head end of each cylinder for position feedback. Limit switches are furnished with submersion protection of integral cables 120 feet long. Also furnished with the SCUBA-II actuator is an actuator electrical Local Control Panel (LCP) for mounting by the contractor in the immediate vicinity of the actuator.

The gates will hold their positions upon a loss of electric power at the LCP. The SCUBA-II actuator is provided with quick-disconnect fittings for connection of hoses from the portable, 2-wheel handcart-mounted pumping unit. Hoses are provided for pump suction and return, and for cap and rod line connections for the cylinder.

The actuator will provide manually controlled opening and closing of either gate from the LCP. It also provides opening and closing operation in response to commands from a remote location (remote controls not included in the scope of Rodney Hunt's supply).

A SCUBA design specification sheet is provided by Rodney Hunt Company for the actuator furnished on this order. Please refer to the specification sheet for design details and drawing information. Presented below is a brief description of the actuator and its electrical controls, and instructions for its operation.

**ACTUATOR FEATURES:**

The actuator will be housed in an enclosure providing protection against the environment as shown on the actuator specification sheet. Installation of the actuator in the field will be as detailed on the installation drawing.

A hydraulic reservoir is provided in the actuator, sized to handle the full oil return volume displaced by the cylinder rods. An electric motor is coupled to a hydraulic gear pump, designed to provide the necessary hydraulic pressure and flow rate to operate the gates. The pump and motor will be vertically mounted with the pump located below the motor and reservoir. Control valve stacks are mounted inside the actuator with a directional valve, load holding valves, pressure control valves, and independently adjustable, opening and closing speed control valves for each gate.

The LCP electrical enclosure is designed for installation in an environment as shown on the specification sheet. Operator controls are provided on a swing-out interior panel behind the lockable enclosure door to prevent unauthorized access. The customer will provide connections for the electrical power feed and any remote control devices as required. Factory-installed cables exit the SCUBA actuator enclosure at conduit hubs suitable for connection of field conduit for pulling the cables to the LCP control enclosure. Refer to the Electrical Schematic drawing for information on interconnecting wiring requirements.

Control logic is provided by a programmable logic controller (PLC) pre-programmed to provide the specified control functions. LOCAL or REMOTE gate operation is chosen using a common selector switch on the LCP. Remote control and status reporting will be accomplished through a fiber-optic Ethernet connection. A small UPS will provide power to the PLC and communication devices for approximately ten minutes following a loss of primary power. The UPS provides the ability to remotely monitor the system status for a brief period; no gate operation is supported without primary power available to operate the pump.

**GATE OPERATION:**

A LAMP TEST pushbutton is provided on the interior operator panel. Pressing this button will illuminate all indicating lights (provided control power is available) for a brief period. Control functions will not be affected.

A *SUMMARY ALARM* relay is provided with a Form-C dry contact, wired to the terminal strip for field connection to remote control equipment. This relay will be held energized during all normal operation and the contacts will change state when the relay is de-energized. The relay will de-energize for any of the following conditions:

- A loss of primary or control power.
- PLC failure or the PLC *NOT* being in RUN mode.
- Low oil level in the hydraulic reservoir.

- Excessive period of operation for gate movement.

*If the Summary Alarm relay is de-energized and there is not an indication at a light as described below, then the operator should investigate a possible power or PLC problem.*

A Control Power On indicating light is lit whenever UPS-supported control power is available. Separate indicating light is lit whenever control power is ON, the PLC is functioning normally, and the controls have detected any of these alarm conditions:

- **LOW OIL LEVEL** - A float switch in the actuator hydraulic oil reservoir will detect an abnormally low oil level. This alarm will be cleared when the oil is restored to the proper level. Normal system operation is prevented by this alarm.
  - *Do not overfill the reservoir.* The usable reservoir capacity above the low level switch is sufficient to accept the volume of fluid displaced by the cylinder rods. Fluid level adjustment should be done with both cylinder rods either fully retracted or fully extended.
- **EXCESSIVE RUN TIME** – The pump operates on a command to move a gate. If a gate has been required to run for an abnormally long time period without detecting full travel at a limit switch, this alarm will be detected and latched in the logic. This alarm may be cleared by pressing the *RESET* pushbutton on the interior operator panel. Normal system operation is prevented by this alarm.

### **NORMAL OPERATION:**

When primary 480 Volt power is connected, 120 Volt AC control power is available from the control power transformer (CPT) and CB1 should be turned ON. With control power ON at CB1, the thermostatically controlled electrical control enclosure heater is energized (fuse F6), power is available to the motor winding heater (F7) and to the thermostatically controlled ventilating fan (FF), and the GFCI duplex receptacle is energized. If CB2 is also ON, power is available to the UPS. At the secondary side of the UPS, if CB3 is ON, power is available to all 120 Volt AC sub-circuits. Power to the PLC processor can be disconnected as a service convenience at CB6. Power to the DC power supply and remote communication devices can be disconnected as a service convenience at CB7. PLC input circuits may be disconnected at CB4, and output circuits may be disconnected at CB 5.

Whenever control power is available and there are no critical alarms, the pump is available to deliver pressurized fluid to the cylinders. In either LOCAL or REMOTE mode, a command to move a gate will start the hydraulic pump, supplying pressurized oil to the normal directional control valve stack. The directional solenoid valve for the intended gate will direct the pressurized oil to either the Opening end of the cylinder (energize solenoid coil B) or to the Closing end of the cylinder (energize solenoid coil A).

**Position Sensing and Indication:**

Limit switches are mounted integrally to the cap and head ends of each cylinder. Each gate is provided with Opened and Closed indicating lights, one of which is lit when limit travel has been detected. When the gate is traveling to a fully opened or closed position, a time delay is provided after the limit switch contact is energized to ensure that the gate has reached its mechanical limit of travel before shutting off the actuator.

**LOCAL and REMOTE modes:**

A three-position *LOCAL-OFF-REMOTE* selector switch is provided on the LCP interior operator panel. This switch determines the location of control for all gates. An isolated REMOTE MODE selector switch contact is wired to terminals for remote notification (at equipment not provided by Rodney Hunt).

When this switch is in the *LOCAL* position, gates are controlled at the LCP using the manual *OPEN, CLOSE, AND STOP* pushbuttons for a given gate. Pressing an Open or Close button will latch the command in the PLC logic until the gate reaches limit travel or the Stop button is pressed. The pump will run for the duration that the gate is required to move.

When the switch is in the *REMOTE* position, the controls will monitor two logical contacts for each gate, controlled by remote equipment. One contact must be On to command the given gate to Open, and the other contact must be On to command the gate to Close. The intended contact must be held On for the duration that the gate is to move. If both contacts are Off, the gate ceases movement. Limit travel will also prevent further gate operation.

In either Local or Remote modes, the logic will latch the status of a given gate being in the fully raised position, and will automatically restore the gate to the fully raised position if the gate drifts downward off of the limit switch. The latch clears when the gate is operated downward or the control mode selector switch is set to OFF.

**OPERATION OF THE GATE WITHOUT ELECTRIC POWER:**

If a directional valve solenoid coil has burned out on the SCUBA-II power module, the directional valve can be overridden by inserting a pointed tool into one end of the directional valve coil and pressing against the centering spring. The pump must be operated by using the LOCAL pushbutton to move the gate in the intended direction, and the directional valve held shifted for the duration of gate movement. When movement is completed, press the Stop button to stop pump operation.

**Portable Pumping Unit:**

The gate can be opened or closed during a loss of power by utilizing the portable pumping assembly provided. Four hoses must be connected to the SCUBA-II actuator. Pump suction and tank return, and cylinder cap and rod line hoses are sized and gendered for connection guidance. The cylinder lines should be connected to the two fittings on the actuator designated for the desired gate. With the hoses connected to the

SCUBA-II actuator, the gas engine should be started and the lever-operated directional valve shifted for opening or closing operation. It is important to stop the engine before disconnecting any hoses. The engine should never be run disconnected from the actuator. Running the engine without moving a gate can lead to overheating of the fluid within a few minutes.



## SECTION 40\_61\_00

### COMMON WORK RESULTS FOR PROCESS CONTROL AND INSTRUMENTATION SYSTEMS

#### PART 1 GENERAL

##### 1.01 SUMMARY

- A. Section includes:
  - 1. General requirements applicable to all Process Control and Instrumentation Work.
  - 2. General requirements for process control and instrumentation submittals.
- B. Related sections:
  - 1. Section 26\_05\_00 - Common Work Results for Electrical.
  - 2. Section 26\_05\_53 - Identification for Electrical Systems.
  - 3. Section 40\_80\_01 - Testing, Calibration, and Commissioning.
- C. Interfaces to equipment, instruments, and other components:
  - 1. Drawings, Specifications, and overall design are based on preliminary information furnished by various equipment manufacturers, which identify a minimum scope of supply from the manufacturers. This information pertains to, but is not limited to, instruments, control devices, electrical equipment, packaged mechanical systems, and control equipment provided with mechanical systems.
  - 2. Provide all material and labor needed to install the actual equipment furnished, include all costs to add any additional instruments, wiring, control system inputs/outputs, controls, interlocks, electrical hardware etc., which may be necessary to make a complete, functional installation based on the actual equipment furnished:
    - a. Make all changes necessary to meet the manufacturer's wiring requirements.
  - 3. Submit all such changes and additions to the Engineer for acceptance.
  - 4. Review the complete set of Drawings and Specifications in order to ensure that all items related to the instrumentation and control systems are completely accounted for. Include any items indicated on the Drawings or in Specifications from another discipline in the scope of Work:
    - a. If a conflict between Drawings and Specifications is discovered, refer conflict to the Engineer as soon as possible for resolution.
  - 5. Loop drawings:
    - a. Provide complete loop drawings for all systems, including packaged equipment furnished as part of a vendor furnished package, and for all pre-purchased equipment.



- b. The form, minimum level of detail, and format for the loop drawings must match that of the sample loop drawings included in the Contract Documents.
  - c. The Owner and Engineer are not responsible for providing detailed loop diagrams for Contractor furnished equipment.
- D. All instrumentation, and control equipment and systems for the entire project to comply with the requirements specified in the Instrumentation and Control Specifications, whether referenced in the individual Equipment Specifications or not:
- 1. The requirements of the Instrumentation and Control Specifications apply to all Instrumentation and Control Work specified in other Specifications, including HVAC controls, packaged mechanical systems, LCPs, VCPs, etc.
  - 2. Inform all vendors supplying instrumentation, control systems, panels, and/or equipment of the requirements of the Instrumentation and Control Specifications.
  - 3. The Owner is not responsible for any additional costs due to the failure of the Contractor to notify all subcontractors and suppliers of the Instrumentation and Control Specifications' requirements.
- E. Contract Documents:
- 1. General:
    - a. The drawings and specifications are complementary and are to be used together in order to fully describe the Work.
  - 2. Specifications:
    - a. These requirements are in addition to all General Requirements.
  - 3. Contract drawings:
    - a. The Instrumentation and Control Drawings show in a diagrammatic manner, the desired locations, and arrangements of the components of the Instrumentation Work. Follow the drawings as closely as possible, use professional judgment and coordinate with the other trades to secure the best possible installation, use the entire drawing set for construction purposes.
    - b. Locations of equipment, control devices, instruments, boxes, panels, etc. are approximate only, exercise professional judgment in executing the Work to ensure the best possible installation:
      - 1) The equipment locations and dimensions indicated on the Drawings and elevations are approximate. Use the shop drawings to determine the proper layout, foundation, and pad requirements, etc. for final installation. Coordinate with all subcontractors to ensure that all instrumentation and control equipment is compatible with other equipment and space requirements. Make changes required to accommodate differences in equipment dimensions.

- 2) The Contractor has the freedom to select any of the named manufacturers as identified in the individual Specifications; however, the Engineer has designed the spatial equipment layout based upon a single manufacturer and has not confirmed that every named manufacturer's equipment fits in the allotted space. It is the Contractor's responsibility to ensure that the equipment being furnished fits within the defined space.
- c. Installation details:
  - 1) The Contract Drawings include installation details showing means and methods for installing instrumentation and control equipment. For cases where typical details are not provided or compatible with an installed location, develop installation details that are necessary for completing the Work, and submit these details for review by the Engineer.
- d. Schematic diagrams:
  - 1) All controls are shown de-energized.
  - 2) Schematic diagrams show control function only. Incorporate other necessary functions for proper operation and protection of the system.
  - 3) Add slave relays, where required, to provide all necessary contacts for the control system or where needed to function as interposing relays for control voltage coordination, equipment coordination, or control system voltage drop considerations.
  - 4) Mount all devices shown on motor controller schematic diagrams in the controller compartment enclosure, unless otherwise noted or indicated.
  - 5) Control schematics are to be used as a guide in conjunction with the descriptive operating sequences indicated on the Drawings or in the Specifications. Combine all information and furnish a coordinated and fully functional control system.

## 1.02 REFERENCES

- A. Code compliance:
  1. The publications are referred to in the text by basic designation only. The latest edition accepted by the Authority Having Jurisdiction of referenced publications in effect at the time of Bid governs.
  2. The following codes and standards are hereby incorporated into this Section:
    - a. American National Standards Institute (ANSI).
    - b. American Petroleum Institute (API):
      - 1) RP 550 - Manual on Installation of Refinery Instruments and Control Systems; Part II-Process Stream Analyzers; Section 5-Oxygen Analyzers.
      - 2) RP 551 - Process Measurement Instrumentation.
    - c. International Organization for Standardization (ISO):
      - 1) 9001 - Quality Management Systems - Requirements.
    - d. International Society of Automation (ISA):
      - 1) 5.1 - Instrumentation Symbols and Identification.

- 2) 5.4 - Instrument Loop Diagrams.
- 3) 20 - Specification Forms for Process Measurement and Control Instruments, Primary Elements, and Control Valves.
- e. National Electrical Manufacturers Association (NEMA):
  - 1) 250 - Enclosures for Electrical Equipment (1000 V Maximum).
- f. National Fire Protection Association (NFPA).
- g. National Institute of Standards and Technology (NIST).
- h. Underwriters Laboratories, Inc. (UL):
  - 1) 508 - Standard of Safety for Industrial Control Equipment.
  - 2) 508A - Standard of Safety for Industrial Control Panels.

### 1.03 DEFINITIONS

- A. Definitions of terms and other electrical and instrumentation considerations in accordance with:
  1. Factory Mutual (FM).
  2. International Electrotechnical Commission (IEC).
  3. Institute of Electrical and Electronics Engineers (IEEE).
  4. International Society of Automation (ISA).
  5. International Organization for Standardization (ISO).
  6. National Electrical Code (NEC).
  7. National Electrical Manufacturers Association (NEMA).
  8. InterNational Electrical Testing Association (NETA).
  9. National Fire Protection Association (NFPA).
  10. National Institute of Standards and Technology (NIST).
  11. Underwriters Laboratories (UL).
- B. Specific definitions:
  1. Control circuit: Any circuit operating at 120 volts alternating current (VAC) or direct current (VDC) or less, whose principal purpose is the conveyance of information (including performing logic) and not the conveyance of energy for the operation of an electrically powered device.
  2. Panel: An instrument support system that may be a flat surface, a partial enclosure, or a complete enclosure for instruments and other devices used in process control systems.
  3. Power circuit: Any circuit operating at 90 volts (AC or DC) or more, whose principal purpose is the conveyance of energy for the operation of an electrically powered device.
  4. Signal circuit: Any circuit operating at less than 50 VAC or VDC, which conveys analog information or digital communications information.
  5. Digital bus: A communication network, such as PROFIBUS, Foundation Fieldbus, or DeviceNet, allowing instruments and devices to transmit data, control functions, and diagnostic information.

6. 2-Wire transmitter (loop powered): A transmitter that derives its operating power supply from the signal transmission circuit and requires no separate power supply connections. As used in this Section, 2-wire transmitter refers to a transmitter that provides a signal such as 4 to 20 mA 24VDC regulation of a signal in a series circuit with an external 24 VDC driving potential:
    - a. Fieldbus communications signal or both.
  7. Powered transmitters: A transmitter that requires a separate power source (120 VAC, 240 VAC, etc.) in order for the transmitter to develop its signal. As used in this Section, the produced signal may be a 4 to 20 mA 24VDC signal, a digital bus communications signal, or both.
  8. System supplier - As specified in ICSC Qualifications in the Quality Assurance article of this Section.
  9. Modifications: Changing, extending, interfacing to, removing, or altering an existing circuit.
- C. NEMA:
1. Type 1 enclosure in accordance with NEMA 250.
  2. Type 2 enclosure in accordance with NEMA 250.
  3. Type 3 enclosure in accordance with NEMA 250.
  4. Type 3R enclosure in accordance with NEMA 250.
  5. Type 3S enclosure in accordance with NEMA 250.
  6. Type 3X enclosure in accordance with NEMA 250.
  7. Type 3RX enclosure in accordance with NEMA 250.
  8. Type 3SX enclosure in accordance with NEMA 250.
  9. Type 4 enclosure in accordance with NEMA 250.
  10. Type 4X enclosure in accordance with NEMA 250.
  11. Type 5 enclosure in accordance with NEMA 250.
  12. Type 6 enclosure in accordance with NEMA 250.
  13. Type 6P enclosure in accordance with NEMA 250.
  14. Type 12 enclosure in accordance with NEMA 250.
  15. Type 12K enclosure in accordance with NEMA 250.
  16. Type 13 enclosure in accordance with NEMA 250.
- D. Acronym definitions:
1. CCS: The PCS central computer system (CCS) consisting of computers and software. The personal computer-based hardware and software system that includes the operator interface, data storage, data retrieval, archiving, alarming, historian, reports, trending, and other higher level control system software and functions.
  2. DPDT: Double-pole, double-throw.
  3. ES: Enterprise system: Computer based communications or data sharing system utilized for non-process control functions such as E-mail, sharing files, creating documents, etc.
  4. FAT: Factory acceptance test also known as Source Test.
  5. HART: Highway addressable remote transducer.

6. HOA: Hand-Off-Auto control function that is totally PLC based. In the Hand mode, equipment is started or stopped, valves are opened or closed through operator direction under the control of the PLC software. In the Auto mode, equipment is started or stopped and valves are opened or closed through a control algorithm within the PLC software. In the Off mode, the equipment is prohibited from responding from the PLC control.
7. HMI: Human machine interface is a software application that presents information to an operator or user about the state of a process, and to accept and implement the operators control instructions. Typically information is displayed in a graphical format.
8. ICSC: Instrumentation and control system contractor: Subcontractor who specializes in the design, construction, fabrication, software development, installation, testing, and commissioning of industrial instrumentation and control systems.
9. IJB: Instrument junction boxes: A panel designed with cord sets to easily remove, replace, or relocate instrument signals.
10. I/O: Input/Output.
11. IP: Internet protocol or ingress protection.
12. LCP: Local control panel: Operator interface panel that may contain an HMI, pilot type control devices, operator interface devices, control relays, etc. and does not contain a PLC or RIO.
13. LAN: Local area network: A control or communications network that is limited to the physical boundaries of the facility.
14. LOI: Local Operator Interface is an operator interface device consisting of an alphanumeric or graphic display with operator input functionality. The LOI is typically a flat panel type of display mounted on the front of an enclosure with either a touch screen or tactile button interface.
15. LOR: Local-Off-Remote control function. In the Remote mode, equipment is started or stopped, and valves are opened or closed through the PLC based upon the selection of the HOA. In the Local mode, equipment is started or stopped, valves are opened or closed based upon hardwired control circuits completely independent of the PLC with minimum interlocks and permissive conditions. In the Off mode, the equipment is prohibited from responding to any control commands.
16. NJB: Network junction box. An enclosure that contains multiple access points to various networks within the facility. Networks could be Ethernet, Ethernet/IP, Fieldbus, RIO, etc.
17. P&ID: Process and instrumentation diagram.
18. PC: Personal computer.
19. PCIS: Process control and instrumentation system: Includes the entire instrumentation system, the entire control system, and all of the Work specified in the Instrumentation and Control Specifications and depicted on the Instrumentation Drawings. This includes all the PCS and instruments and networking components as well as the various servers, workstations, thin clients, etc.

20. PCM: Process control module: An enclosure containing any of the following devices: PLC, RTU, or RIO.
21. PCS: Process Control System: A general name for the computerized system that gathers and processes data from equipment and sensors and applies operational controls to the process equipment. It includes the PLCs and/or RIOs, LOIs, HMIs, both LCPs, VCPs and all data management systems accessible to staff.
22. PJB: Power junction box: An enclosure with terminal blocks that distribute power to multiple instruments.
23. PLC: Programmable logic controller.
24. RIO: Remote I/O device for the PLC consisting of remote I/O racks, or remote I/O blocks.
25. RTU: Remote telemetry unit: A controller typically consisting of a PLC, and a means for remote communications. The remote communications devices typically are radios, modems, etc.
26. SCADA: Supervisory control and data acquisition system: A general name for the computerized system that gathers and processes data from sensors and equipment located outside of the facility, such as wells, lift stations, metering stations, etc.
27. SPDT: Single-pole, double-throw.
28. SPST: Single-pole, single-throw.
29. UPS: Uninterruptible power supply.
30. VCP: Vendor control panel: Control panels that are furnished with particular equipment by a vendor other than the ICSC. These panels may contain PLCs, RIO, LOI, HMI, etc.
31. WAN: Wide area network: A control or communications network that extends beyond the physical boundaries of the facility.

#### 1.04 SYSTEM DESCRIPTION

##### A. General requirements:

1. The Work includes everything necessary for and incidental to executing and completing the instrumentation and control system work indicated on the Drawings and specified in the Specifications and reasonably inferable there from including but not limited to:
  - a. Preparing hardware submittals for field instrumentation.
  - b. Design, develop, and draft loop drawings, control panel designs, and all other drawing submittals specified in the Instrumentation and Control Specifications.
  - c. Prepare the test plan, the training plan, and the spare parts submittals.
  - d. Procure all hardware.
  - e. Provide all PCS system hardware.
  - f. Provide all PCS system software.
  - g. Fabricate panels.
  - h. Perform factory tests on panels.
  - i. Perform bench calibration and verify calibration after installation.
  - j. Oversee and certify installation of the PCS system.

- k. Oversee, document, and certify loop testing.
  - l. Oversee, document, and certify system.
  - m. Installation Testing.
  - n. Oversee and document Functional Testing.
  - o. Conduct the Process Operational Period and the Instrumentation and Controls Process Performance Testing.
  - p. Prepare operation and maintenance manuals.
  - q. Conduct training classes.
  - r. Integrate the PCS with instrumentation and control devices provided under other sections.
  - s. Provide Record Drawings and Loop Drawings associated with Instruments and equipment:
    - 1) As specified in the Contract Documents.
    - 2) For Owner furnished items.
    - 3) For interfaces with existing equipment.
  - t. Resolve signal, power, or functional incompatibilities between the PCS and interfacing devices.
  - u. Perform all required corrective and preventative maintenance.
2. It is the intent of these Specifications that the entire electrical power, instrumentation, and control system be complete and operable. Provide all necessary material and labor for the complete system from source of power to final utilization equipment, including all connections, testing, calibration of all equipment furnished by others, as well as equipment furnished by the Contractor, whether or not specifically mentioned but which are necessary for successful operation.
  3. Provide the complete operating PCS to perform the specified monitoring, communications, alarm, control, display, and reporting functions in accordance with the PCS requirements.
  4. Coordinate all aspects of the Work between Contractor and all subcontractors before bidding to ensure that all costs associated with a complete installation are included. The Owner is not responsible for any change orders due to lack of coordination of the Work between the Contractor, the ICSC, the other subcontractors, or suppliers.
  5. Furnish detailed, complete, and thorough operations and maintenance documentation, including but not limited to operations manuals, maintenance manuals, as-built wiring drawings, training manuals, as-built software documentation, and all other documentation required to operate, modify, and maintain all parts of the PCS.
  6. Where demolition is indicated on the Drawings, the electrical subcontractor is responsible for disconnecting equipment electrical connections and rendering the equipment safe. The ICSC is responsible for physically removing all instrumentation to be demolished and return it either to the Owner or dispose of it as directed by the Owner's representative. The ICSC shall be responsible for any program modifications needed based on the demolition of the equipment, both for the loops directly and indirectly affected.

7. Portions of this Project involve installation in existing facilities and interfaces to existing circuits, power systems, controls, and equipment.
    - a. Perform and document comprehensive and detailed field investigations of existing conditions (circuits, power systems, controls, equipment, etc.) before performing any Work.
    - b. Provide and document interface with, modifications to, upgrade, or replacement of existing circuits, power systems, controls, and equipment.
  8. Revise in a manner as directed by the Engineer all I/O and addressing that the Engineer determines to be unacceptable as a result of a lack of Contractor coordination between Contract Documents and all suppliers.
- B. Existing system:
1. Pond 001 cell one and two that are feed by way of an existing gate structure. These existing ponds capture drainage from controlled hard surfaces. The gates are controlled by way of a Rodney Hunt hydraulic system. The gates can be operated in a hand or automatic mode. Each pond cell level is monitored by a bubbler panel. The ponds are tied to a pump station wet well that is able to pump to the facilities treatment or discharge system. Flow is monitored by an existing flow meter.
  2. This project is a control system upgrade that encompasses many automation upgrades. The project will require implementation in several phases as specified. Each phase will need to be planned and fully executed as if they were individual projects. This includes submittals, programming development meetings, testing, and training.
- C. New system:
1. Addition of a new Pond 001 cell three.
  2. The new instrumentation, control, and network installation shall match the existing system as much as possible to have standardization throughout the facility.
  3. New Rodney Hunt hydraulic control panel.
  4. New pond 001 cell level transmitter and associated equipment to transmit cell level. Provide surge protection at the instrument and in the PLC panel.
  5. Provide new 24VDC power supply to power new level transmitter (and 24VDC heater on level transmitter) and the new surge suppressor located in the PLC cabinet.
  6. Additional pilot devices will be added to the front of the PLC cabinet - rearrange device labels (to match existing colors and font heights and style) and wire pilot devices as indicated in the drawings.
  7. Program the PLC to add the new components being furnished in this project, and match functionality of the existing systems.
  8. Update Owners existing Intellution/iFix system to add the new Cell, levels, gates, volumes, status, alarms and trends and.



D. Operating facility:

1. Portions of this existing facility must remain fully functional throughout the entire construction period. In consideration of this requirement, comply with the following guidelines:
  - a. All outages must be of minimal duration and fully coordinated and agreed to by the Owner. Adjust the construction to meet the requirements of the Owner.
  - b. As weather and facility demand conditions dictate, re-adjust the construction schedule to meet the demands placed upon Owner by its users.
  - c. Where portions of the Work are in existing facilities and require interface to existing circuits, power systems, controls and equipment, perform comprehensive and detailed field investigations of existing conditions. Determine all information necessary to document, interface with, modify, upgrade, or replace existing circuits, power systems, controls, and equipment.
  - d. Temporary control systems:
    - 1) Provide temporary controls at the following locations in order to keep the facility fully operational during Work on the electrical and control systems:
      - a) Existing pond 001 cells one and two.
      - b) Existing pump station.
2. According to individual circumstances and in compliance with the Drawings, extend or replace conduit and cable connections from existing locations.
3. Where shown or specified, replace existing field instruments with new.
4. The Contractor is responsible for the integrity and measurement accuracy of all loops. However, any defect found in existing equipment is the responsibility of the Owner.
5. The standards of documentation, instrument tagging, cable and conductor termination, terminal identification and labeling that apply to the new installation apply equally to the existing installation.

## 1.05 SUBMITTALS

A. Furnish submittals as specified in this Section.

B. General:

1. Instruct all equipment suppliers of submittals and operation and maintenance manuals of the requirements in this Section.
2. Furnish the submittals required by each section in the Instrumentation Specifications.
3. Adhere to the wiring numbering scheme specified in Section 26\_05\_53 throughout the Project:
  - a. Uniquely number each wire.
  - b. Wire numbers must appear on all Equipment Drawings.
4. Use equipment and instrument tags, as indicated on the Drawings, for all submittals.

- C. Submittal organization:
1. First page:
    - a. Specification section reference.
    - b. Name and telephone number of individual who reviewed submittal before delivery to Engineer.
    - c. Name and telephone number of individual who is primarily responsible for the development of the submittal.
    - d. Comments.
    - e. Contractor's review certification statement and signature.
  2. Next pages:
    - a. Provide confirmation of specification compliance:
      - 1) Specification section: Include with each submittal a copy of the relevant specification section.
        - a) Indicate in the left margin, next to each pertinent paragraph, either compliance with a check (√) or deviation with a consecutive number (1, 2, 3).
        - b) Provide a list of all numbered deviations with a clear explanation and reason for the deviation.
      - b. Include a response in writing to each of the Engineer's comments or questions for submittal packages which are re-submitted:
        - 1) In the order that the comments or questions were presented throughout the submittal.
        - 2) Referenced by index section and page number on which the comment appeared.
        - 3) Acceptable responses to Engineer's comments are either:
          - a) Engineer's comment or change is accepted and appropriate changes are made.
          - b) Explain why comment is not accepted or requested change is not made.
          - c) Explain how requirement will be satisfied in lieu of comment or change requested by Engineer.
        - 4) Any re-submittal, which does not contain responses to the Engineer's previous comments shall be returned for Revision and Re-submittal.
        - 5) No further review by the Engineer will be performed until a response for previous comments has been received.
    3. Remaining pages:
      - a. Actual submittal data:
        - 1) Organize submittals in exactly the same order as the items are referenced, listed, and/or organized in the specification section.
        - 2) For submittals that cover multiple devices used in different areas under the same specification section, the submittal for the individual devices must list the area where the device is intended to be used.

D. Submittal requirements:

    1. Furnish submittals that are fully indexed with a tabbed divider for every component.

2. Sequentially number pages within the tabbed sections. Submittals and operation and maintenance manuals that are not fully indexed and tabbed with sequentially numbered pages, or are otherwise unacceptable, will be returned without review.
3. Furnish submittals in the following general order, each in a separate bound set:
  - a. Schedule of Values.
  - b. Product Data.
  - c. After Engineer acceptance of the Product Data, submit the Project Shop Drawing submittals.
  - d. Loop Description Submittal.
  - e. The Process Control Hardware and Software Submittal including, control system software, programming, and screens.
  - f. Testing, Calibration and Process Start-Up procedures.
  - g. Operation and Maintenance Data.
  - h. Training Submittals.
  - i. Record Documents.
4. Edit all submittals and operation and maintenance manuals so that the submittal specifically applies to only the equipment furnished.
  - a. Neatly cross out all extraneous text, options, models, etc. that do not apply to the equipment being furnished, so that the information remaining is only applicable to the equipment being furnished.
5. Submit copies of shop drawings, and product data:
  - a. Show dimensions, construction details, wiring diagrams, controls, manufacturers, catalog numbers, and all other pertinent details.
6. Where submittals are required, provide a separate submittal for each specification section. In order to expedite construction, the Contractor may make more than 1 submittal per specification section, but a single submittal may not cover more than 1 specification section:
  - a. The only exception to this requirement is when 1 specification section covers the requirements for a component of equipment specified in another section. (For example, circuit breakers are a component of switchgear. The switchgear submittal must also contain data for the associated circuit breakers, even though they are covered in a different specification section.)
7. Exceptions to Specifications and Drawings:
  - a. Include a list of proposed exceptions to the Specifications and Drawings along with a detailed explanation of each.
  - b. If there is insufficient explanation for the exception or deviation, the submittal will be returned requiring revision and re-submittal.
  - c. Acceptance of any exception is at the sole discretion of the Engineer.
    - 1) Provide all items (materials, features, functions, performance, etc.) required by the Contract Documents that are not accepted as exceptions.
  - d. Replace all items that do not meet the requirements of the Contract Documents, which were not previously accepted as exceptions, even if the submittals contained information indicating the failure to meet the requirements.

- E. Submittal preparation:
1. During the period of preparation of submittals, the Contractor shall authorize direct, informal liaison between the ICSC and the Engineer for exchange of technical information. As a result of this liaison, certain minor refinements and revisions may be authorized informally by the Engineer, which do not alter the scope of Work or cause increase or decrease in the Contract price or times. During this informal exchange, no oral statement by the Engineer shall be construed to give formal approval of any component or method, nor shall any statement be construed to grant exception to, or variation from, these Contract Documents.
  2. In these Contract Documents, some items of Work are represented schematically, and are designated for the most part by numbers, as derived from criteria in ISA-5.1:
    - a. Employ the nomenclature and numbers designated in this Section and indicated on the Drawings exclusively throughout shop drawings, data sheets, and similar submittals.
    - b. Replace any other symbols, designations, and nomenclature unique to a manufacturer's, suppliers, or subcontractor's standard methods with those identified in this Section and indicated on the Drawings.
- F. Specific submittal requirements:
1. Shop drawings:
    - a. Required for materials and equipment listed in this and other sections.
    - b. Furnish sufficient information to evaluate the suitability of the proposed material or equipment for the intended use, and for compliance with these Specifications.
    - c. Shop drawings requirements:
      - 1) Front, side, and, rear elevations, and top and bottom views, showing all dimensions.
      - 2) Locations of conduit entrances and access plates.
      - 3) Component layout and identification.
      - 4) Schematic and wiring diagrams with wire numbers and terminal identification.
      - 5) Connection diagrams, terminal diagrams, internal wiring diagrams, conductor size, etc.
      - 6) Anchoring method and leveling criteria, including manufacturer's recommendations for the Project site seismic criteria.
      - 7) Weight.
      - 8) Finish.
      - 9) Nameplates:
        - a) As specified in Section 26\_05\_53 or as indicated on the Drawings.
      - 10) Temperature limitations, as applicable.
    - d. Use equipment and instrument tags as depicted on the P&IDs for all submittals.

- e. Adhere to wiring numbering scheme outlined in Section 26\_05\_53 throughout the Project:
    - 1) Uniquely number each wire per the Specifications.
  - f. Wire numbers must appear on all equipment drawings.
  - g. Organize the shop drawing submittals for inclusion in the Operation and Maintenance Manuals:
    - 1) Furnish the initial shop drawing submittal bound in one or more standard size, 3-ring, D-ring, loose leaf, vinyl plastic, hard cover binders suitable for bookshelf storage.
    - 2) Binder ring size: 2 inches.
  - h. Include the letterhead and/or title block of the firm responsible for the preparation of all shop drawings. Include the following information in the title block, as a minimum:
    - 1) The firm's registered business name.
    - 2) Firm's physical address, email address, and phone number.
    - 3) Owner's name.
    - 4) Project name and location.
    - 5) Drawing name.
    - 6) Revision level.
    - 7) Personnel responsible for the content of the drawing.
    - 8) Date.
  - i. The work includes modifications to existing circuits:
    - 1) Clearly show all modifications to existing circuits.
    - 2) In addition, show all existing unmodified wiring to clearly depict the functionality and electrical characteristics of the complete modified circuits.
2. Product data:
- a. Submitted for non-custom manufactured material listed in this and other sections and shown on shop drawings.
  - b. Include:
    - 1) Catalog cuts.
    - 2) Bulletins.
    - 3) Brochures.
    - 4) Quality photocopies of applicable pages from these documents.
    - 5) Identify on the data sheets the Project name, applicable specification section, and paragraph.
    - 6) Identify model number and options for the actual equipment being furnished.
    - 7) Neatly cross out options that do not apply or equipment not intended to be supplied.
  - c. Use equipment and instrument tags as depicted on the P&IDs for all submittals.
  - d. Adhere to wiring numbering scheme outlined in Section 26\_05\_53 throughout the Project:
    - 1) Uniquely number each wire per the Specifications.
  - e. Wire numbers must appear on all equipment drawings.

3. Detailed sequence of operation for all equipment or systems.
4. Operation and maintenance manuals:
  - a. Submit preliminary sets of these manuals to the Engineer for review of format and content:
    - 1) Engineer will return 1 set with comments.
    - 2) Revise and/or amend as required and submit the requisite number of copies to the Engineer 15 days before Functional Testing of the systems.
  - b. Incorporate changes that occur during process start-up and submit as part of the final manuals.
  - c. Provide comprehensive information on all systems and components to enable operation, service, maintenance, and repair.
  - d. Include Record Documents and the accepted shop drawing submittals, modified for conditions encountered in the field during the work.
  - e. Include signed results from Functional Testing and Process Operational Period.
  - f. Provide installation, connection, operating, calibration, setpoints (e.g., pressure, pump control, time delays, etc.), adjustment, test, troubleshooting, maintenance, and overhaul instructions in complete detail.
  - g. Provide exploded or other detailed views of all instruments, assemblies, and accessory components together with complete parts lists and ordering instructions.
  - h. Spare parts list:
    - 1) Include a priced list of recommended spare parts for all the equipment furnished under this Contract:
      - a) Include recommended quantities sufficient to maintain the furnished system for a period of 5 years.
    - 2) Annotate the list to indicate which items, if any and quantity are furnished as part of this Contract.
  - i. Provide the name, address, and phone number of manufacturer and manufacturer's local service representative of these parts.
  - j. Additional operation and maintenance manual requirements:
    - 1) Completely index manuals with a tab for each section:
      - a) Each section containing applicable data for each piece of equipment, system, or topic covered.
      - b) Assemble manuals using the accepted shop drawings, and include, the following types of data:
        - (1) Complete set of 11-inch by 17-inch drawings of equipment.
        - (2) Complete set of 11-inch by 17-inch drawings of the control system.
        - (3) Complete set of control schematics.
        - (4) Complete parts list for all equipment being provided.
        - (5) Catalog data for all products or equipment furnished.

- k. Operational Manual:
  - 1) Prepare and provide a simplified version of the standard manufacturer's HMI software and system operations manual that includes basic instructions in the application of the system as required for operators in day-to-day operations.
- l. Control System Software Record Documents:
  - 1) Include complete documentation of all the software programs provided for the entire control and PCS system, including:
    - a) Listings of all application software on both hard copy and DVD, DVD-ROM, and CD-ROM.
    - b) Database, both hard copy and DVD, DVD-ROM, and CD-ROM.
    - c) Communication protocols.
    - d) All documentation necessary to maintain, troubleshoot, modify, or update the software system.
- m. Organize the operation and maintenance manuals for each process in the following manner:
  - 1) Section A - Process and Instrumentation Diagrams.
  - 2) Section C - Loop Drawings.
  - 3) Section E - Instrument Data Sheets and Brochures.
  - 4) Section H - Test Results.
  - 5) Section I - Operational Manual.
  - 6) Section J - Spare Parts List.
- 5. Material and equipment schedules:
  - a. Furnish a complete schedule and/or matrix of all materials, equipment, apparatus, and luminaries that are proposed for use:
    - 1) Include sizes, names of manufacturers, catalog numbers, and such other information required to identify the items.
- 6. Itemized instrument summary:
  - a. Submit a hard copy of the instrument summary.
  - b. List all of the key attributes of each instrument including:
    - 1) Tag number.
    - 2) Manufacturer.
    - 3) Model number.
    - 4) Service.
    - 5) Area location.
    - 6) Calibrated range.
    - 7) Loop drawing number.
  - c. Associated LCP, VCP, PCM, or PLC.

7. Instrument data sheets and cut sheets:
  - a. Furnish fully completed data sheets, both electronically in Microsoft Word or Excel and in hard copy, for each instrument and component according to ISA-20 Specification Forms for Process Measurement and Control Instruments, Primary Elements and Control Valves. The data sheets provided with the instrument specifications are preliminary and are not complete. They are provided to assist with the completion of final instrument data sheets. Additional data sheets may be required. Include the following information on the data sheet:
    - 1) Component functional description specified in this Section and indicated on the Drawings.
    - 2) Manufacturers model number or other product designation.
    - 3) Tag number specified in this Section and indicated on the Drawings.
    - 4) System or loop of which the component is a part.
    - 5) Location or assembly at which the component is to be installed.
    - 6) Input and output characteristics.
    - 7) Scale range with units and multiplier.
    - 8) Requirements for electric supply.
    - 9) Requirements for air supply.
    - 10) Power consumption.
    - 11) Response timing.
    - 12) Materials of construction and of component parts that are in contact with, or otherwise exposed to, process media, and or corrosive ambient air.
    - 13) Special requirements or features, such as specifications for ambient operating conditions.
    - 14) Features and options that are furnished.
  - b. Provide a technical brochure or bulletin (“cut sheet”) for each instrument on the project. Submit with the corresponding data sheets:
    - 1) Where the same make and model of instrument is used in 2 or more applications on the project, and the process applications are nearly identical, and the materials, features and options are identical submit one brochure or bulletin for the set of identical instruments.
    - 2) Include a list of tag numbers for which it applies with each brochure or bulletin.
    - 3) Furnish technical product brochures that are complete enough to verify conformance with all Contract Document requirements, and to reflect only those features supplied with the device.
    - 4) Cross out models, features, options, or accessories that are not being provided.
    - 5) Clearly mark and identify special options and features.
  - c. Organization: Index the data sheets and brochures in the submittal by systems or loops.
8. Control panel hardware submittal:
  - a. Submit the following in 1 submittal package.



- b. Complete and detailed bills of materials:
    - 1) Including quantity, description, manufacturer, and part number for each assembly or component for each control panel.
    - 2) Include all items within an enclosure.
  - c. Complete grounding requirements for each system component including any requirements for PLCs, process LANs, and Control System equipment.
  - d. Requirements for physical separation between control system components and 120 VAC, 480 VAC, and medium voltage power cables.
  - e. UPS and battery load calculations to show that the backup capacity and time meet the specified requirements.
  - f. Provide a data sheet for each control system component together with a technical product brochure or bulletin, which include:
    - 1) The manufacturer's model number or other identifying product designation.
    - 2) Input and output characteristics.
    - 3) Requirements for electric power.
    - 4) Device ambient operating requirements.
    - 5) Materials of construction.
9. Installation recommendations:
- a. Submit the manufacturer's printed recommendations for installation of instrumentation equipment.
10. Training submittals:
- a. Develop and submit for review a general training plan for approval by Owner within 14 calendar days from Notice to Proceed. Include complete descriptions of all planned training classes, a preliminary training schedule, a list of all proposed instructors along with resumes, examples of proposed training manuals, and a description of any special training tools to be used (simulators, self-paced modules, personal computer-based training, etc.).
  - b. The Engineer will review the general training plan. Special emphasis will be placed on review of the qualifications of the proposed instructors and the timing of the individual courses to maximize their effectiveness. If, in the opinion of the Engineer, the proposed instructors are not sufficiently qualified to conduct the specified training courses, or lack experience, where required, on the specific configuration of the system, provide more qualified instructors.
  - c. The general training plan and schedule shall be updated by the Contractor at the beginning of each Phase and approved by the Owner a minimum of 30 days prior to commencement of training.
  - d. Training course plan submittals:
    - 1) For each training course or other training activity, submit a detailed, complete outline and agenda for each lesson.
    - 2) Describe any student pre-requisites for the course or training activity.
    - 3) Provide an updated schedule for all sessions of the course, including dates, times, durations, and locations.

- 4) Submit training materials.
  - e. Incorporate all submittal review comments into the course.
  - f. Do not conduct training courses before review and acceptance of the Course Plan submittal for the course.
11. Project Record documents:
- a. Record Drawing requirements:
    - 1) Provide Project Record Drawing of all Instrumentation Drawings.
    - 2) Update Record Drawings weekly.
    - 3) Record Drawings must be fully updated as a condition of the monthly progress payments.
    - 4) Clearly and neatly show all changes including the following:
      - a) All existing pipe, conduit, wire, instruments or other structures encountered or uncovered during construction.
  - b. Shop drawings:
    - 1) General:
      - a) Coordinate all aspects of the Work so that a complete, instrumentation, computer, and control system for the facility is supported by accurate shop and record drawings:
        - (1) Clearly show every wire, circuit, and terminal provided under this contract on one or more submitted wiring diagrams.
      - b) Show all interfaces between any of the following: instruments, vendor control panels, motor control centers, motor starters, variable speed drives, control valves, flow meters, chemical feeders, and other equipment related to the PCS.
      - c) Generate all drawings developed for this project utilizing AutoCAD by Auto Desk Version 2012 or later:
        - (1) Furnish on CD-ROM disks containing the following for each drawing:
          - (a) Original CAD files in DWG format.
          - (b) PDF version.
        - (2) Provide hard copies on 11 inch by 17 inch plain bond paper.
      - d) Upon completion of the Work, update all shop drawings to indicate the final as-built configuration of the systems:
        - (1) Should an error be found in a shop drawing during installation or process start-up of equipment, note the correction, including any field changes found necessary, on the drawing and submit the corrections in the Record Documents.
        - (2) Update, check, and revise all wiring drawings and other submitted drawings and documents to show final installed conditions.
        - (3) Provide as-built shop drawings for all instrumentation equipment on 11 inch by 17-inch using plain bond paper.

- (4) Provide electronic copies of these documents on CD-ROM disks in AutoCAD DWG 2010 format or later and PDF format. Size all drawings to be readable and legible on 11 inch by 17-inch media.
      - e) Submittal Documents:
        - (1) Provide an interim submittal of Record Documents after the PCS system Functional Testing.
        - (2) Submit final Record Documents before Substantial Completion or earlier if so specified in the General Requirements.
      - f) Review and Corrections:
        - (1) Correct any Record Documents or other documents found to be incomplete, not accurate, of poor quality, or containing errors.
        - (2) Promptly correct and re-submit Record Documents returned for correction.
    - 2) Furnish written information prepared specifically for this Project using Microsoft Word and PDF formats and printed on 8.5-inch by 11-inch plain bond paper:
      - a) Provide electronic copies of these documents on CD-ROM disks.
  - c. Review and corrections:
    - 1) Correct any record documents or other documents found to be incomplete, not accurate, of poor quality, or containing errors.
    - 2) Promptly correct and re-submit record documents returned for correction.
12. Loop Drawings:
  - a. Submit loop drawings for every analog, discrete, and fieldbus signal and control circuit:
    - 1) Provide a loop drawing submittal that completely defines and documents the contents of each monitoring, alarming, interlock, and control loop on this Project.
    - 2) This requirement applies to all signal and control circuits associated with equipment on this Project including vendor supplied equipment packages and control panels.
    - 3) Provide loop drawings in the format indicated in the contract drawings. Provide all tagging in accordance with the Owner's standard.
  - b. Show every instrument and I/O point on at least one loop diagram.
  - c. Provide a complete index in the front of each bound volume:
    - 1) Index the loop drawings by systems or process areas.
  - d. Provide drawings showing definitive diagrams for every instrumentation loop system:
    - 1) Show and identify each component of each loop or system using requirements and symbols from ISA-5.4.
    - 2) Furnish a separate drawing sheet for each system or loop diagram.

- e. In addition to the ISA-5.4 requirements, show the following details:
    - 1) Functional name of each loop.
    - 2) Reference name, drawing, and loop diagram numbers for any signal continuing off the loop diagram sheet.
    - 3) Show all terminal numbers, regardless of the entity providing the equipment.
    - 4) MCC panel, circuit, and breaker numbers for all power feeds to the loops and instrumentation.
    - 5) Designation of and, if appropriate, terminal assignments associated with, every manhole, pull-box, junction box, conduit, and panel through which the loop circuits pass.
    - 6) Show vendor control panel, instrument panel, conduit, junction box, equipment and PCS terminations, termination identification, wire numbers and colors, power circuits, and ground identifications.
    - 7) If a circuit is continued on another drawing, show the name and number of the continuation drawing on the loop drawing. Provide complete references to all continuation drawings whether vendor control panels, other loop drawings, existing drawings provided by the Owner, or other drawings.
  - f. In addition to the above requirements, provide loop diagrams in accordance with the example loop diagram as indicated on the Drawings.
13. Instrument Installation Drawings:
- a. Submit, instrument installation, mounting, and anchoring details for all components and assemblies, including access requirements and conduit connection or entry details.
  - b. Furnish for each instrument a dedicated 8 1/2-inch by 11-inch installation detail that pertains to the specific instrument by tag number.
  - c. For each detail, provide certification and the hard copies, by the instrument manufacturer, that the proposed installation is in accordance with the instrument manufacturer's recommendations and is fully warrantable.
  - d. For each detail, provide, as a minimum, the following contents:
    - 1) Necessary sections and elevation views required to define instrument location by referencing tank, building or equipment names and numbers, and geographical qualities such as north, south, east, west, basement, first floor, etc.
    - 2) Ambient temperature and humidity where the instrument is to be installed.
    - 3) Corrosive qualities of the environment where the instrument is to be installed.
    - 4) Hazardous rating of the environment where the instrument is to be installed.
    - 5) Process line pipe or tank size, service and material.
    - 6) Process tap elevation and location.
    - 7) Upstream and downstream straight pipe lengths between instrument installation and pipe fittings and valves.
    - 8) Routing of tubing and identification of supports.

- 9) Mounting brackets, stands, anchoring devices, and sun shades.
  - 10) Conduit entry size, number, location, and delineation between power and signal.
  - 11) NEMA ratings of enclosures and all components.
  - 12) Clearances required for instrument servicing.
  - 13) List itemizing all manufacturer makes, model numbers, quantities, lengths required, and materials of each item required to support the implementation of the detail.
14. Control Panel Drawings:
- a. Layout Drawings:
    - 1) Submit panel, enclosure, console, furniture, and cabinet layout drawings for all items provided.
    - 2) As a minimum, include the following information:
      - a) To scale front, side, and plan views.
      - b) Dimensions.
      - c) Interior and exterior arrangements.
      - d) Mounting information, including conduit entrance location.
      - e) Finish data.
      - f) Tag number and functional name of items mounted in and on each panel, console, and cabinet.
      - g) Nameplate legend including text, letter size, materials, and colors.
  - b. Wiring and piping diagrams:
    - 1) Submit panel wiring and piping diagrams for every panel that contains wiring and/or piping.
    - 2) Include the following information:
      - a) Name of panel.
      - b) Wiring and piping sizes and types.
      - c) Terminal strip numbers.
      - d) Wire tags and labels.
      - e) Functional name and manufacturer's designation for items to which wiring and piping are connected.
      - f) Electrical control schematics in accordance with ANSI standards.
15. Control System Diagram:
- a. Submit a complete set of control system diagrams including the following information:
    - 1) All PLCs, workstations, printers, communication devices, and communication links:
      - a) Show all PLCs with their current I/O allocation, and future I/O allocation, current plus spares provided, and maximum potential I/O based on available slots.
    - 2) All cables required for communication requirements.
    - 3) Show each component fully annotated with conduit size and number associated with the power source.

16. Test reports:
  - a. Include the following:
    - 1) A description of the test.
    - 2) List of equipment used.
    - 3) Name of the person conducting the test.
    - 4) Date and time the test was conducted.
    - 5) All raw data collected.
    - 6) Calculated results.
    - 7) Each report signed by the person responsible for the test.]
17. Calculations:
  - a. Where required by specific Instrumentation Specifications:
    - 1) Because these calculations are being provided by a registered professional engineer, they will be reviewed for form, format, and content but will not be reviewed for accuracy and calculation means.

## **1.06 QUALITY ASSURANCE**

- A. Manufacture instruments at facilities certified to the quality standards of ISO 9001.
- B. Furnish all equipment listed by and bearing the label of UL or of an independent testing laboratory acceptable to the Engineer and the Authority Having Jurisdiction.
- C. The ICSC must have their own operating UL listed panel fabrication facility. All panels must be fabricated at this facility and meet all UL 508/508A requirements.
- D. ICSC:
  1. The Contractor, through the use of a qualified ICSC, is responsible for the implementation of the PCIS and the integration of the system with other required instrumentation, control devices, and software.
  2. The ICSC assumes full responsibility, through the Contractor, to perform all work to select, furnish, install, program, test, calibrate, and place into operation all instrumentation, controls, telemetry equipment, control panels, and control system including application software, for a complete, integrated and functional PCIS system.
  3. Due to the complexities associated with the interfacing of numerous control system devices, it is the intent of these Specifications that the ICSC be responsible for the integration of the PCIS with existing devices and devices provided under the Contract Documents with the objective of providing a completely integrated control system.

## **1.07 DELIVERY, STORAGE, AND HANDLING**

- A. Store all equipment and materials delivered to the job site in a location that will not interfere with the construction or the Owner's operations.

- B. Shipping precautions:
  - 1. After completion of shop assembly, successful Source Test, pack all equipment, cabinets, panels, and consoles in protective crates and enclose in heavy-duty polyethylene envelopes or secured sheeting to provide complete protection from damage, dust, and moisture.
  - 2. Place dehumidifiers when required, inside the polyethylene coverings.
  - 3. Skid-mount the equipment for final transport.
  - 4. Provide lifting rings for moving without removing protective covering.
  - 5. Display boxed weight on shipping tags together with instructions for unloading, transporting, storing, and handling at the job site.
- C. Special instructions:
  - 1. Securely attach special instructions for proper field handling, storage, and installation to each piece of equipment before packaging and shipment.
- D. Tagging:
  - 1. Tag each component and/or instrument to identify its location, instrument tag number, and function in the system.
  - 2. Firmly attach a permanent tag indelibly machine marked with the instrument tag number, as given in the tabulation, on each piece of equipment constituting the PCS.
  - 3. Tag instruments immediately upon receipt in the field.
  - 4. Prominently display identification on the outside of the package.
  - 5. Utilize the Tag and Loop Number identifications shown on the P&IDs.
- E. Delivery and inspection:
  - 1. Deliver products in undamaged condition, in manufacturer's original container or packaging with identifying labels intact and legible. Include date of manufacture on label.

## 1.08 PROJECT OR SITE CONDITIONS

- A. Site conditions:
  - 1. Provide a PCS, including all equipment, raceways, and any other components required for a complete installation that meets the environmental conditions for the Site as specified in the General Requirements and below.
  - 2. Seismic classification:
    - a. Provide all equipment and construction techniques suitable for the seismic requirements for the site.
  - 3. Wind:
    - a. Provide all equipment and construction techniques suitable for the site wind loading criteria.
  - 4. Altitude, temperature and humidity:
    - a. Provide all equipment and instrumentation fully rated for continuous operation at this altitude, temperature and humidity conditions with no additional derating factors applied.

- b. Provide additional temperature conditioning equipment to maintain all equipment and instrumentation in non-conditioned spaces or outdoors subject to these ambient temperatures 10 degrees Fahrenheit above the minimum operating temperature and 10 degrees Fahrenheit below maximum operating temperature as determined by the equipment manufacturer's guidelines:
  - 1) Provide all power wiring for these devices (e.g., heaters, fans, etc.), whether or not indicated on the Drawings.
- 5. Area classifications:
  - a. Furnish enclosures that match the area classifications as specified in Section 26\_05\_00.
- 6. Site security:
  - a. Abide by all security and safety rules concerning the Work on the Site.

## 1.09 SEQUENCING

### A. General:

- 1. Testing requirements are specified in Section 40\_80\_01 and other sections.

### B. Pre-submittal conferences:

- 1. Before producing any submittals, schedule a pre-submittal conference for the purposes of reviewing the entire project, equipment, control philosophy, schedules, and submittal requirements.
- 2. The Contractor, instrumentation and control subcontractor, electrical subcontractor, and all manufacturers furnishing major pieces of equipment must attend, including but not limited to:
  - a. Vendor control panels.
  - b. Chemical feed systems.
  - c. Motor control centers.
  - d. Switchgear.
  - e. Variable frequency drives.
  - f. Lighting.
  - g. Engine generators.
- 3. The Programmer shall be invited to attend the pre-submittal conference.

### C. System configuration meetings:

- 1. Review the system configuration, the system database, control schemes, displays, report formats, etc. with the Engineer and Owner on at least 3 occasions during development.
- 2. Preliminary meeting: Before configuration work is begun. The ICSC must bring to this meeting example of displays, display symbols, reports, etc. to show the capabilities of the system software.
- 3. Intermediate review meeting: Held after the initial database is entered and typical screens and reports have been entered.
- 4. Final review meeting: Held after initial completion of all configuration work. This final meeting may not be held in conjunction with the Source Test. Make final format revisions after this review.



5. Additional requirements as specified in Sections 40\_61\_15, 40\_64\_02 and 40\_68\_16.
  6. Vendor Equipment Meetings: Facilitate a meeting with each equipment supplier (including HVAC) who is providing equipment with a PLC and/or LOI. Meeting discussion point will include the following at a minimum:
    - a. Tag Naming Conventions.
    - b. PLC to PLC global data mapping.
    - c. All PLCs to HMI tags mapping.
    - d. LOI screen colors and navigation.
    - e. Interlock and Permissive definitions.
    - f. Communication Methods.
    - g. Standard code blocks for common control functionality.
    - h. Alarms: Clearing, formats, colors, and status.
  7. Final review meeting: Held after all HMI/LOI interface submittals have been submitted. Meet to discuss HMI/LOI interface submittals and requirements.
  8. Additional requirements as specified in Sections 40\_61\_15, 40\_64\_01, and 40\_68\_16. Individuals responsible for programming PLCs and other programmable devices supplied by Contractor shall attend this meeting by telephone conference call.
  9. Commence after acceptance of all training, wire test, calibration tests, and loop validation tests, and all inspections have demonstrated that the PCIS complies with all Contract requirements.
  10. Acceptance of the PCIS Installation testing must be provided in writing by the Owner before the performance testing may begin.
- D. Functional testing:
1. Representatives from each of the following groups shall be in attendance during the functional Testing: Programmer, System Supplier Commence after acceptance of all training, wire test, calibration tests, and loop validation tests, and all inspections have demonstrated that the PCIS complies with all Contract requirements.
  2. Loop validation test.
  3. As specified in Section 40\_80\_01.
    - a. Notify the Owner of scheduled tests a minimum of 21 days before the estimated completion date of installation and wiring of the PCIS.
    - b. Complete loop validation testing a minimum of 5 days before the pre-commissioning phase of the project.
    - c. Loop validation certifications:
      - 1) After the field device loop tests have been successfully completed as specified in Section 40\_80\_01 for all individual instruments, all separate analog control networks, all valves, all VCPs, all motors, all local operator interface panels, all motor control centers, etc., submit a certified copy of all test forms signed by the Contractor, Vendor, and the Owner's representative with test data entered, together with a clear and unequivocal statement that all instrumentation, including all control and signal wiring, has been successfully calibrated, inspected, and tested.

- a) Acceptance of the PCIS Installation Testing must be provided in writing by the Engineer before the Process Operational Period may begin.
  - d. The Programmer will assist with Functional Testing for PLCs programmed by the Programmer, as specified in Section 40\_80\_01.
  - e. The Programmer shall not be required to be on site, nor shall the Programmer be required to supply application software, until the loop validation tests are complete for a PLC and all prerequisites for the Process Operational Period are completed.
- E. Provide all special tools and spare parts, as specified in the Maintenance paragraph of this Section, before Process Operational Period commences, suitably wrapped, and identified.
- F. Process Operational Period:
- 1. Upon completion of the Process Operational Period, conduct an Instrumentation and Controls Process Performance Test as a condition for Project final completion.

#### **1.10 WARRANTY**

- A. Provide additional warranty as specified in the individual Instrumentation and Control Specifications that extends beyond the Correction Period.

#### **1.11 SYSTEM PROCESS START-UP**

- A. Replace or modify equipment, software, and materials that do not achieve design requirements after installation in order to attain compliance with the design requirements:
  - 1. Following replacement or modification, retest the system and perform additional testing to place the complete system in satisfactory operation and obtain compliance acceptance from the Engineer.

#### **1.12 MAINTENANCE**

- A. Before Substantial Completion, perform all maintenance activities required by the Contract Documents including any calibrations, final adjustments, component replacements or other routine service required before placing equipment or systems in service.
- B. Furnish all spare parts as required by the Contract Documents.
- C. Provide additional spare parts specified in other sections of the Instrumentation and Control Specifications.
- D. Submit all special tools and spare parts, suitably wrapped and identified, before Process Operational Period commences.

---

## **PART 2 PRODUCTS**

### **2.01 MANUFACTURERS**

- A. Provide similar items from a single manufacturer throughout the PCIS portion of the Project.
- B. Allowable manufacturers are specified in individual instrument and equipment specifications.

### **2.02 MATERIALS**

- A. Furnish all materials under this Contract that are new, free from defects, and standard products produced by manufacturers regularly engaged in the production of these devices and that bear all approvals and labels as required by the Specifications.
- B. Provide materials complying with the applicable industrial standard as specified in the Contract Documents.

### **2.03 COMPONENTS**

- A. Furnish all meters, instruments, and other components that are the most recent field proven models marketed by their manufacturers at the time of submittal of the shop drawings unless otherwise specified to match existing equipment.
- B. Unless otherwise specified, furnish individual instruments that have a minimum accuracy of within 0.5 percent of full scale and a minimum repeatability of within 0.25 percent of full scale.
- C. Signal transmission:
  - 1. Analog signals:
    - a. Furnish analog measurements and control signals that vary in direct linear proportion to the measured variable, unless otherwise indicated.
    - b. Furnish electrical analog signals outside control panels that are 4 to 20 milliamperes 24 VDC, except as indicated.
    - c. Analog signals within enclosures may be 1 to 5 VDC.
    - d. Electrically or optically isolate all analog signals from other signals.
    - e. Furnish regulated analog signals that are not affected by changes in supply voltage or load resistance within the unit's rating.
    - f. Maintain the total 4 to 20 milliamperes loop impedance to 10 percent below the published value at the loop operating voltage.
    - g. Where necessary, reduce loop impedance by providing current-to-current (I/I) isolation amplifiers for signal re-transmission.
  - 2. Pneumatic signals:
    - a. All pneumatic signals: 3 to 15 pounds per square inch gauge.
  - 3. Discrete input signals:
    - a. As indicated in the controller hardware specification.

4. Discrete output signals:
  - a. Dry contacts or TRIAC outputs (with express written approval by the Engineer) as needed to coordinate with the field device.
  - b. Provide external terminal block mounted fuse with blown fuse indication for all discrete outputs.
  - c. Provide interposing relays for all discrete outputs for voltage and/or current compatibilities.
  - d. Provide interposing relays as required for functionality of the control circuit.
5. Signal performance and design criteria:
  - a. Stability:
    - 1) After Controls have taken corrective action, oscillation of the final control element shall not exceed 2 cycles per minute or a magnitude of motion of 0.5 percent of full travel.
  - b. Response:
    - 1) Any change in setpoint or controlled variable shall produce a corrective change in position of the final control element and stabilized within 30 seconds.
  - c. Agreement:
    - 1) Setpoint indication of controlled variable and measured indication of controlled variable shall agree within 3 percent of full scale over a 6:1 operating range.
  - d. Repeatability:
    - 1) For any repeated magnitude of control signal, from either an increasing or decreasing direction, the final control element shall take a repeated position within 0.5 percent of full travel regardless of force required to position the final element.
  - e. Sensitivity:
    - 1) Controls shall respond to a setpoint deviations and measured variable deviations within 1.0 percent of full scale.
  - f. Performance:
    - 1) All instruments and control devices shall perform in accordance with the manufacturers' specifications.
- D. Discrete circuit configuration:
  1. Configure discrete control circuits to fail safe, on loss of continuity or loss of power.
  2. Alarm contacts: Fail to the alarm condition.
  3. Control contacts fail to the inoperative condition unless otherwise indicated on the Drawings.
- E. Grounding:
  1. Provide control panels with a signal ground bus, isolated from the power ground bus:
    - a. Provide multiple panels in one location with a common point for signal ground bus connection to ground.

2. Ground single point ground shields and measurement loops at the source panel external terminals, unless otherwise noted, by bonding to the control panel signal ground bus.
  3. Provide isolating amplifiers within control panels for field equipment possessing a grounded input or output, except when the panel circuit is galvanically isolated.
- F. Instrument air:
1. Where indicated on the Drawings, provide dry, filtered control air at 30 pounds per square inch gauge nominal pressure piped to all field instruments and instrument panels requiring air:
    - a. Provide each field instrument with an integral, non-adjustable filter/regulator assembly to provide regulated air.
    - b. Provide each instrument panel requiring air with an adjustable filter/regulator assembly with gauge and an air manifold to provide air to pneumatic instruments.
    - c. Filter all air to 5 micron maximum particle size.
    - d. Provide low pressure switch to alarm on insufficient air supply.

## 2.04 ACCESSORIES

- A. Provide flow conditioning devices or other required accessories if necessary to meet the accuracy requirements in the Contract Documents.
- B. Nameplates:
1. Provide a nameplate for each controller, instrument transducer, instrument power supply, solenoid, or any other control device located either in the field or within panels.
  2. All nameplates shall be of identical style, color, and material throughout the facility.
  3. Device nameplates shall include:
    - a. Designations as indicated on the Drawings and identified on the Process and Instrumentation Drawings.
      - 1) Device tag and loop number ID (e.g., FIT-60.011).
      - 2) PLC ID (e.g., PLC-11).
      - 3) Power information (e.g., PCM-11, 120VAC).
    - b. White lettering on a black background, laminated plastic.
  4. All instruments shall be equipped with Type 316 stainless steel nameplate with the instrument tag stamped in 3/8-inch letters and connected to the instrument using Type 316 stainless steel wire.

## 2.05 SOURCE QUALITY CONTROL

- A. Provide all equipment that is new, free from defects, and standard products produced by manufacturers regularly engaged in the production of these products that bear all approvals and labels as required by the Specifications.

- B. Arrange with all manufacturers of the equipment and fabricators of panels and cabinets, to allow the Owner and Engineer to inspect and witness the testing of the equipment at the site of fabrication:
  - 1. Equipment includes the cabinets, special control systems, flow measuring devices, and other pertinent systems and devices.
- C. Source Test is specified in Section 40\_80\_01.

## **PART 3 EXECUTION**

### **3.01 EXAMINATION**

- A. The ICSC is encouraged to visit the site and examine the premises completely before bidding. It is the ICSC's responsibility to be fully familiar with the existing conditions and local requirements and regulations.
- B. Review the existing Site conditions and examine all shop drawings for the various items of equipment in order to determine exact routing and final terminations for all wiring and cables.
- C. Provide a complete instrumentation and control system:
  - 1. Install all extra conduits, cables, and interfaces as may be necessary to provide a complete and operating electrical, and process control and instrumentation system.

### **3.02 INSTALLATION**

- A. Equipment locations indicated on the Drawings may change due to variations in equipment size or minor changes made by others during construction:
  - 1. Verify all dimensions as indicated on the Drawings:
    - a. Actual field conditions govern all final installed locations, distances, and levels.
  - 2. Review all information indicated on the Drawings, including architectural, structural, mechanical, instrumentation, and the accepted electrical, instrumentation, and mechanical shop drawings, and coordinate Work as necessary to adjust to all conditions that arise due to such changes.
  - 3. Make minor changes in location of equipment before rough in, as directed by the Owner or Engineer.
- B. Perform all related Electrical Work in accordance with the applicable sections of the Electrical Specifications.
- C. The PCIS configurations are diagrammatic:
  - 1. The locations of equipment are approximate unless dimensioned.
  - 2. Where Project conditions require, make reasonable changes in locations and arrangements.

- D. Field instruments installation:
1. Install field instruments as specified in the Contract Documents, API RP 550 and RP 551, and the manufacturer's instructions.
  2. Mount field instruments so that they can be easily read, readily approached, and easily serviced, and so they do not restrict access to mechanical equipment:
    - a. Mount field instruments on a pipe stand or local panel, if they are not directly mounted, unless otherwise indicated on the Drawings.
    - b. Provide sun shields for all field electronic instruments exposed to direct sunlight.
  3. Make connections from rigid conduit systems to field instruments with PVC coated flexible conduit:
    - a. Type of flexible conduit required for the area classification:
      - 1) Area classification as specified in Section 26\_05\_00.
    - b. Maximum length of 18 inches.
  4. Connect field instruments with cable as specified in the Electrical Specifications, except when the manufacturer requires the use of special cable, or otherwise specified in this Section:
    - a. Special cable applications shall be in accordance with the NEC.
  5. Verify the correctness of each installation:
    - a. Polarity of electric power and signal connections.
  6. Ensure all process connections are free of leaks.
- E. Process sensing lines and air tubing:
1. Install individual tubes parallel and/or perpendicular to and near the surfaces from which they are supported.
  2. Provide supports for rigid tubing at intervals of not more than 3 feet.
  3. Slope horizontal runs of instrument tubing at a minimum of 1/16th inch per foot to allow for draining of any condensate.
  4. Bends:
    - a. Use proper tool.
    - b. Make bends for parallel lines symmetrical.
    - c. Make bends without deforming or thinning the walls of the tubing.
  5. Square-cut and clean all ends of tubing before being inserted in the fittings.
  6. Provide bulkhead fittings at all panels requiring pipe and/or tubing entries.
  7. Use stainless steel tubing for all piping hard piped from the air header, unless otherwise indicated on the Drawings or not compatible with the fluids or atmosphere in the area:
    - a. Use flexible connections only on moving equipment and under the constraint that the length shall be less than 1.5 times maximum travel of the equipment.
- F. Conduit, cables, and field wiring:
1. Provide all PCS equipment cables, and process LAN communication networks under the Instrumentation and Control Specifications.
  2. Provide terminations and wire identification as specified in the Electrical Specifications.
  3. Protect all wiring from sharp edges and corners.

4. Provide all conduits, fittings, boxes, etc. in accordance with all the requirements of the Electrical Specifications.
- G. Equipment tie-downs:
1. Anchor all instruments, control panels, and equipment by methods that comply with seismic and wind bracing requirements, which apply to the Site.
  2. All control panels, VCPs, LCPs, RTUs, PCMs, etc., shall be permanently mounted and tied down to structures.
- H. Existing instrumentation:
1. Clean, recondition and re-calibrate each existing instrument to be reused, removed, or reinstalled using an authorized service facility of the instrument manufacturer.
  2. Provide certification of this Work before reinstallation of each instrument.
- I. Instrument tagging:
1. As specified in Section 26\_05\_53.
  2. Provide all field-mounted instruments with nameplates:
    - a. Nameplates engraved with the instrument's full tag number as indicated on the Drawings:
      - 1) Affix tags with stainless steel wire fasteners.
  3. Provide all back of panel instruments with nameplates:
    - a. Engraved with the instrument's full tag number as indicated on the Drawings:
  4. Provide all front of panel instruments with a nameplate:
    - a. Engraving to include the following:
      - 1) Instrument's full tag number.
      - 2) Service description.
    - b. Nameplates:
      - 1) Secure nameplates to the panel with stainless steel screws.
      - 2) Use an accepted adhesive if screws would violate the NEMA or other ratings of the enclosure.
- J. Cable and conductor termination:
1. Terminate all cables and conductors on terminal blocks.
  2. Terminal block enclosures:
    - a. Suitable for the area classification as specified in Section 26\_05\_00.
- K. Surge protection:
1. Provide outdoor field instrument loops with voltage surge protection units installed on the instruments and the panel.
  2. Individually fuse each 4 to 20 milliamperes direct current loop with a 1/16 ampere fuse between power supplies and receiver surge protectors.
  3. Provide voltage surge protection for 4 wire transmitters and analyzers:
    - a. Protect both power source and signal loop.



### 3.03 COMMISSIONING

- A. Owner Training:
1. Demonstration requirements are specified in Section 40\_80\_01.
  2. General:
    - a. Provide system maintenance and operator training courses for all the instrumentation and control systems furnished.
    - b. Provide system maintenance and operator training courses for all the instrumentation and control equipment and systems furnished, as described below.
      - 1) All training described below shall be provided by the Contractor.
      - 2) The Programmer is not responsible for the training described in this Section.
      - 3) The Programmer will provide training on software provided by the Programmer.
    - c. Conduct all training at the Project Site unless another location is accepted by the Engineer and Owner:
      - 1) Include instruction on the use of all maintenance equipment and special tools provided under the Contract.
    - d. Tailor training classes to the specific needs of the class participants:
      - 1) Develop separate courses for operators, maintenance staff, and supervisors:
        - a) The specific categories and number of personnel in each category are identified below.
      - 2) Furnish training courses that are a combination of classroom and hands-on training:
        - a) To the greatest extent possible, utilize components from the Owner's PCS system.
        - b) Limit classes that include extensive hands-on activities to a maximum of 5 students per class.
      - 3) Present the minimum number of sessions, specified in Table 40\_61\_00-3.10-T1, for each course in order to satisfy class size restrictions and limitations scheduling Owner staff.
      - 4) Furnish additional sessions if required to accommodate the total number of personnel identified for each course.
    - e. Schedule individual training classes:
      - 1) Coordinate with the Owner at least 3 weeks before the start of the class:
      - 2) Schedule training classes Monday - Friday between 7:30 a.m. and 3:30 p.m.
      - 3) Each individual daily training session, travel time excluded:
        - a) Minimum duration of hours.
        - b) Maximum duration of 7 hours.
        - c) Breaks scheduled at least every 90 minutes and 1 hour for lunch.
      - 4) Complete training for maintenance personnel 90 days before Process Operational Period.

- 5) Complete operator training classes before process start-up of the control system software, or any part of it:
  - a) As specified in the Sequencing article of this Section.
- 6) Schedule follow-up training classes after the PCS start-up on a schedule determined by the Owner.
- f. Instructor qualifications:
  - 1) Highly qualified training instructors for technical training with demonstrated expertise in not only control system functionality but also professional training techniques:
    - a) Instructor qualifications are subject to the approval of the Engineer.
  - 2) Furnish training instructors thoroughly familiar with the PCIS system, who are members of the implementation team.
  - 3) One of the individuals conducting the PCIS training course must be the same individual responsible for the majority of the programming that was performed for the instrumentation and control system.
3. Training manuals and materials:
  - a. Furnish training manuals and other materials for training courses.
  - b. Manuals are to be professionally written to present the course material in a format that is easy to comprehend.
  - c. The manuals are to serve as teaching aids during presentation of the training classes.
  - d. Manuals are to serve as reference material after the training has been completed.

| <b>Table 1</b>            |  |   |                                   |
|---------------------------|--|---|-----------------------------------|
| <b>Course Title</b>       | <b>Minimum Course Length (hours per session)</b> | <b>Personnel (Estimated Number of Students)</b> | <b>Minimum Number of Sessions</b> |
| System Overview           | 2  | 10  | 1                                 |
| Operator Training - Basic | 2  | 10  | 2                                 |
| Instrument Training       | 2  | 3   | 1                                 |

4. Training course requirements:
  - a. System overview training:
    - 1) Furnish training courses that give the Owner's supervisory level personnel an overview of all elements of the PCIS system that focus on the overall functional aspect of elements of the control system and provide an understanding of the interaction of the various components.

- b. Operator training:
  - 1) Furnish training courses that instruct system operators in the efficient operation of all aspects of the PCIS that include not only the general operation of the control system but also the operation of specific system features.
  - 2) Operator's training shall include the following for each vendor package and programmable device:
    - a) Control system overview: Architecture, equipment functions, software components, etc.
    - b) Display navigation, overview, and types of displays.
    - c) Process and equipment monitoring and control: Basic principles and operation.
    - d) Logging ON and OFF the system and description of the security and access system.
    - e) Alarm subsystem.
    - f) Trending: Provide a thorough session on how to use all trending functions.
    - g) Reports: How to access, print, and review content.
    - h) Control strategies: Present an average 15-minute review of each control strategy, including a hands-on demonstration of screens and operator functions for each.
- c. Instrumentation training:
  - 1) Furnish training covering all instruments and control panels.
  - 2) Furnish the specified quantity of training, allocated to cover new instruments and hardwired controls as specified in this Section and specifically determined in the accepted training plan.
  - 3) Train maintenance staff in the use, cleaning, calibration, maintenance, and troubleshooting of all the instruments furnished within this Project.
  - 4) Furnish training on the operation of new hardwired controls.

### 3.04 FIELD QUALITY CONTROL

- A. Inspection:
  - 1. Allow for inspection of PCIS installation.
  - 2. Provide any assistance necessary to support inspection activities.
  - 3. Engineer inspections may include, but are not limited to, the following:
    - a. Inspect equipment and materials for physical damage.
    - b. Inspect installation for compliance with Drawings and Specifications.
    - c. Inspect installation for obstructions and adequate clearances around equipment.
    - d. Inspect equipment installation for proper leveling, alignment, anchorage, and assembly.
    - e. Inspect equipment nameplate data to verify compliance with design requirements.
    - f. Inspect cable terminations.
    - g. Inspect/witness instrument calibrations/verifications.

4. Inspection activities conducted during construction do not satisfy inspection requirements specified in Section 40\_80\_01.
- B. Instrument Installation Inspection:
1. Provide any assistance necessary to support inspection activities.
  2. Inspections may include, but are not limited to, the following:
    - a. Inspect equipment and materials for physical damage.
    - b. Inspect the installed arrangement, lay lengths, orientation, piping obstructions, etc., that could affect the instruments accuracy or repeatability.
    - c. Inspect installation for compliance with Drawings and Specifications.
    - d. Inspect installation for obstructions and adequate clearances around equipment.
    - e. Inspect equipment installation for proper leveling, alignment, anchorage, and assembly.
    - f. Inspect equipment nameplate data to verify compliance with design requirements.
    - g. Inspect cable terminations.
    - h. Inspect/witness instrument calibrations/verifications.
  3. Inspection activities conducted during construction do not satisfy inspection requirements specified in Section 40\_80\_01.
  4. Field acceptance testing: (Functional Testing) is specified in Section 40\_80\_01.
- C. Installation supervision:
1. Ensure that the entire PCIS is installed in a proper and satisfactory manner. At a minimum, the ICSC shall provide the following services:
    - a. Installation resources:
      - 1) Coordinate with the Contractor regarding installation requirements of the Contract Documents.
    - b. Provide technical assistance to installation personnel by telephone:
      - 1) Furnish installation personnel with at least one copy of the accepted submittals, including all installation details.
    - c. Periodic inspections during the construction period.
    - d. A complete check of the completed installation to ensure that it is in conformance with the requirements of the equipment manufacturer and the Contract Documents.
    - e. Field verify accuracy and calibration of all instruments.

### 3.05 ADJUSTING

- A. Control valves:
1. Stroke all control valves, cylinders, drives and connecting linkages from the control system as well as local control devices and adjust to verify proper control action, hand switch action, limit switch settings, torque settings, remote control actions, and remote feedback of valve status and position.
  2. Check control valve actions and positioner settings with the valves in place to ensure that no changes have occurred since the bench calibration.

- B. Make all revisions necessary to the control system software, as directed by the Engineer.
  - 1. It is understood that the Contractor knows and agrees that changes will be required in the control system software during the Source Testing, Functional Testing, Process Operational Period, Process Start-Up, and during the Project Correction Period.

### **3.06 CLEANING**

- A. Vacuum clean all control panels and enclosures before process start-up and again after final completion of the project.
- B. Clean all panel surfaces.
- C. Return to new condition any scratches and/or defects.
- D. Wipe all instrument faces and enclosures clean.
- E. Leave wiring in panels, manholes, boxes, and other locations in a neat, clean, and organized manner:
  - 1. Neatly coil and label all spare wiring lengths.
  - 2. Shorten, re-terminate, and re-label excessive spare wire and cable lengths, as determined by the Engineer.
- F. As specified in other sections of the Contract Documents.

### **3.07 PROTECTION**

- A. Protect all Work from damage or degradation until date of Substantial Completion.

## **PART 4 MEASUREMENT**

### **4.01 METHOD OF MEASUREMENT**

- A. No separate measurement shall be made for work under this Section.

## **PART 5 PAYMENT**

### **5.01 METHOD OF PAYMENT**

- A. No separate payment will be made for work under this Section. The cost of the work described in this Section shall be included in the applicable lump sum bid item.

END OF SECTION

## SECTION 40\_61\_15

### CONTROL STRATEGIES

#### PART 1 GENERAL

##### 1.01 SUMMARY

- A. Section includes:
  - 1. Contractor-developed loop description submittal requirements.
  - 2. General programming requirements.
  - 3. Common control functions:
    - a. General control and monitoring functions to be provided throughout the PCIS system.
      - 1) These requirements apply to all systems, and supplement the specific loop descriptions in Section 40\_61\_16 and information indicated on the Drawings.
- A. Related sections:
  - 1. Section 40\_61\_00 - Common Work Results for Process Control and Instrumentation Systems.
  - 2. Section 40\_61\_16 - Specific Control Strategies.

##### 1.02 REFERENCES

- A. As specified in Section 40\_61\_00.

##### 1.03 DEFINITIONS

- A. As specified in Section 40\_61\_00.
- B. Hardwired control: Control circuitry that does not utilize software to initiate functionality.
- C. Hardwired interlocks: A safety or protective feature that will interrupt operation of the equipment in all operating modes with no required operator intervention.
- D. Software interlocks: A safety or protective feature that will interrupt operation of the equipment when the PLC has control.
- E. Slew rate: Rate of change in respect to time.
- F. Clamp: Imposed upper and lower limits on setpoints to eliminate entries outside the allowable control parameters.
- G. Watchdog timer: Timers imposed to test components such as discrete I/O to verify the health of the card.

## 1.04 SUBMITTALS

- A. As specified in Section 40\_61\_00.

## 1.05 WARRANTY

- A. As specified in Section 40\_61\_00.

## PART 2 PRODUCTS

Not Used.

## PART 3 EXECUTION

### 3.01 ERECTION, INSTALLATION, APPLICATION, CONSTRUCTION

- A. As specified in Section 40\_61\_00.
- B. General programming requirements:
  - 1. Use variable names or aliases derived from tag and loop identification on the P&IDs for all process values.
    - a. Unless otherwise noted, utilize floating-point format for all PLC algorithms and calculations.
    - b. Provide PLC logic to convert raw input values into engineering units in a floating-point format.
  - 2. Documentation:
    - a. All control logic shall be completely annotated including all rungs, instructions, and tags.
    - b. Each routine shall have a title and a detailed description of the control strategy represented by the control logic. Where parameters are passed to the routine, all parameters shall be defined in the routine description.
    - c. Analog tag descriptions representing process variables shall include the engineering unit range of the analog variable.
    - d. Digital tag descriptions shall include the On and Off state labels.
    - e. Complete, grammatically correct sentences and terminology, consistent with water treatment processes, shall be utilized in the development of rung and routine descriptions.
    - f. All equations developed in the process logic shall be fully documented in the rung or routine description. A description of each constant and variable utilized in the equation shall be defined including engineering units.
  - 3. Calculated values:
    - a. Program calculations such that division by zero errors cannot occur.
    - b. Prevent calculations from generating values that exceed the limits of the equipment or data type structures (integers) internal to the PLC.

- c. Configure counting functions (start counts and operation counts) to allow a minimum of 10,000 counts, and to roll-over to zero at an even decimal interval (1 followed by 4 or more zeros).
  - d. Configure integrating functions to accurately accumulate the maximum rate from the instrument/equipment (totalizers, run time meters) for 30 years.
4. Timers:
- a. Provide programmable settling and proving timers in all control sequences for starting and stopping of equipment to allow the process to settle down before proceeding with any additional control functions.
    - 1) The settling timers may be overridden by setting the timer to 0 seconds.
  - b. Embed the timers in the PLC logic, tune in the field, and list separately as part of the software submittal and O&M manual.
5. Control Panel status:
- a. Design the PLC system to function as a stand-alone unit that performs all of the control functions described herein completely independent from the functions of the PCS system PC-based operator interfaces:
    - 1) Failure of the PCS system shall not impact data acquisition, control, scaling, alarm checking, or communication functions of the PLC.
  - b. Furnish a minimum of 1 screen that depicts the status of all enclosures containing PLCs, communication equipment, UPSs or I/O in the control system, including but not limited to the following:
    - 1) PLC cabinet over-temperatures from high temperature switch.
    - 2) Intrusion status on all enclosures equipped with intrusion switches.
    - 3) AC power failure:
      - a) Monitor ahead of UPS.
    - 4) DC power supply failure:
      - a) For redundant power supplies, alarm when either power supply or the diode bridge fails.
    - 5) UPS failure signal.
    - 6) UPS Low Battery signal.
    - 7) Digital bus network combrick failure signal.
    - 8) Ethernet Switch failure signal.
6. PLC system communication status:
- a. Furnish a minimum of 1 screen to display all communication errors and status within the PCIS:
    - 1) Communication between PCS and PLCs, PLC to PLC, PLC to RIO and PLC and or PCS to VCP.
  - b. Generate a communications alarm if any communication fault is detected or there is no response from a node for more than a user specified time.
  - c. In the event of communications loss:
    - 1) Continue normal operation at each PLC.



- 2) Where control parameters are received over a communications link:
    - a) If a link fails where process elements use the remote value for closed-loop control, hold operating status, speed and position, of the process elements at their last state before the communication alarm, unless other I/O local to that PLC indicates shutdown or over-ride conditions:
      - (1) Ensure that the operator can control the process using PCIS HAND mode at the local LOI.
    - b) If a link fails where process elements use the remote value to determine setpoints, settings or control levels, continue to operate using the last value received:
      - (1) Provide a manual over-ride entry at the local LOI to allow an operator to enter a different value for any such remote signal.
      - (2) Generate an alarm whenever an over-ride value is in use.
- C. Common control functions:
1. Incorporate common control functions into all control loops and devices and into the control programming, whether or not specifically shown in the specific control descriptions or elsewhere in the Contract Documents.
  2. Alarms:
    - a. Generate alarms within the PLC logic.
    - b. Indicate alarms at the LOI and HMI. Enable acknowledgement from either the HMI or the LOI.
    - c. Generate high, high-high, low, and low-low level alarms where indicated:
      - 1) Provide an alarm reset deadband for each analog value to prevent excessive repeated alarms.
      - 2) Provide logic and timers to inhibit analog alarms based on process events. For example, inhibit low flow alarms when a pump is stopped, or has not been running long enough to establish flow.
    - d. Flash all alarm and fail conditions and their respective indicators on the PCIS graphic screens and local indicating lights until the condition is acknowledged by the operator, even if the alarm condition is no longer present.
    - e. Once the alarm is acknowledged by an operator, display alarm conditions in a steady state (not flashing) while the alarm condition is still present:
      - 1) Flash with a cycle rate of 1/2 second on and 1/2 second off.
    - f. Once the alarm has been cleared and the operator has acknowledged the alarm or fail condition, turn the graphic alarm indicator off.
    - g. For all alarms that do not have inherent timers, provide an operator-adjustable proving timer to limit nuisance alarms, continuously adjustable from zero seconds to 100 minutes. The initial setting of proving timers shall be zero seconds:
      - 1) The PLC shall start the timer when it first detects an alarm condition, and shall only activate the alarm after the timer has expired.
      - 2) If the alarm condition clears while the timer is running, the timer shall reset, and the alarm shall not be activated.

- h. Use interlocks and proving timers to prevent alarms from operating due to power loss, except for loss of power alarms.
        - i. Furnish an alarm silence pushbutton at each PCM, LOI, or LCP with an audible alarm to signal the PLC to turn off the audible alarm until the next alarm occurs.
        - j. Any alarm that is not acknowledged after a setpoint period of time shall activate the auto dialer.
3. For all monitored analog values:
  - a. Convert all values to engineering units in floating-point format within the PLC.
  - b. Maintain trends in PCS.
  - c. Totalize flows in the PLC logic:
    - 1) Where totalized flows are input to a discrete input, count input pulses and multiply by the volume per pulse.
    - 2) Where no totalizer input is shown, integrate the analog input over time.
    - 3) Display totals on the HMI and LOI.
    - 4) Archive totals to the historical database through PCS.
  - d. Calculate hourly, daily, and monthly averages:
    - 1) Calculations may be performed by the PLC or PCS.
    - 2) Display averages on the HMI, and archive through PCS.
  - e. Calculate minimum and maximum values for each hour, day, and month:
    - 1) Calculations may be performed by the PLC or PCS.
    - 2) Display minima and maxima on the HMI, and archive through PCS.
  - f. Generate an alarm whenever an over-ride value is in use.
4. Analog data processing:
  - a. Engineering units conversion:
    - 1) Use engineering units for all analog point values. Convert analog inputs to engineering units.
  - b. Analog magnitude checking:
    - 1) Provide upper and lower limits to prevent operator-entered values (setpoints, etc.) from falling outside acceptable limits.
  - c. Analog value quality:
    - 1) Monitor analog values received at each PLC from analog inputs or communications from another PLC or RIO, and generate alarms for the following conditions:
      - a) Rate of change in excess of acceptable limit:
        - (1) Provide a separate rate limit for each value.
      - b) Stale value:
        - (1) For analog signals that come from analog inputs or calculations using analog inputs, which are expected to have some variation each time the input is read, alarm when there is no change in the value for 10 times the normal expected scan or communication update.

5. Tank and vessel levels:
  - a. Display all tank and vessel levels as both a level (typically in feet) and a volume (typically in gallons):
    - 1) Some individual displays may be only level or volume, when agreed to by the Owner and Engineer during screen meetings.
  - b. Monitor rate of change of volume on all tanks and vessels:
    - 1) Establish the maximum withdraw rate at which the volume should decrease (all pumps or feeders operating at maximum output). Generate an alarm whenever the volume decreases faster than this rate.
    - 2) Establish the minimum fill rate at which the volume should increase when filling. Generate an alarm whenever the volume increases faster than this rate. Verify tank and vessel level is fluctuating to verify the validity of the IO register. If it is determined the register is not active or failed in a manner that leaves a stagnant value generate an alarm.
6. PCIS HAND-OFF-AUTO:
  - a. Where indicated, provide HAND-OFF-AUTO and START-STOP selections in the PCIS, accessed from an LOI or HMI for operators with sufficient security, to provide the following operating modes:
    - 1) PCIS AUTO: The normal, automatic control mode of the strategy which allows full PLC control in response to process conditions and programmed sequences.
    - 2) PCIS HAND: Enables PCIS Manual control where control decisions are made by an operator through the PCIS START-STOP, OPEN/CLOSE, or other selections as indicated.
    - 3) PCIS OFF: Automated PCIS control is disabled and PLC calls for all associated equipment to stop and valves to close or go to their identified safe state.
    - 4) Program the PLC so that switching a strategy between AUTO and HAND (either direction) occurs with a smooth transition. Keep running or position status unchanged when control is switched to HAND until a change is requested using the operator selections (START, STOP, OPEN, CLOSE). Keep running and position status unchanged when control is switched to AUTO until the control logic determines a change is required.
7. Display the current status of all operator selections (PCIS HAND/AUTO, PCIS START/STOP, etc.) on LOI and HMI.
8. Permissives:
  - a. Implement software permissives where indicated to place equipment in a safe condition in response to impending hazardous process conditions. Apply software permissives when equipment is operating in PCIS AUTO or PCIS HAND:
  - b. Use hard-wired permissives for equipment protection where indicated.

9. Process control algorithms:
  - a. Jog and hold: Unless otherwise indicated, use jog and hold control algorithms where possible:
    - 1) When the error between process variable and setpoint is beyond a setpoint deadband:
      - a) Jog valve or ramp speed in the required direction for a preset “Jog Time” or until the process variable reaches or passes the setpoint.
      - b) Then hold speed or position through a setpoint “Hold Time.”
      - c) Continue alternating jog and hold until the error is less than the deadband.
    - 2) Provide operator access to Jog Time and Hold Time setpoints from the HMI.
10. Gate and valve control:
  - a. Monitor the device’s LOCAL-STOP-REMOTE (LSR) switch(es) (the integral switch in the actuator or hard-wired switch at the local control station):
    - 1) Display current REMOTE status on PCIS screens.
  - b. Start an “Open Activation” timer whenever the device is expected to be open (PLC has issued an OPEN command in PCIS AUTO, or OPEN was selected in PCIS HAND):
    - 1) Initially set “Open Activation” time to twice the normal opening time.
    - 2) If the LSR position and open command do not change, and the PLC does not receive fully open status feedback within the “Open Activation” time period:
      - a) De-activate the open output.
      - b) Place the device in a “Failed” state.
      - c) Generate a “Failed to Open” alarm.
  - c. Start a “Close Activation” timer whenever the device is expected to be closed (PLC has issued a CLOSE command in PCIS AUTO, or CLOSE was selected in PCIS HAND):
    - 1) Initially set “Close Activation” time to twice the normal closing time.
    - 2) If the LSR position and close command do not change, and the PLC does not receive fully closed status feedback within the “Close Activation” time period:
      - a) De-activate the close output.
      - b) Place the device in a “Failed” state.
      - c) Generate a “Failed to Close” alarm.
  - d. For modulating valves (valves controlled from either a 4-20 mA signal or digital communications command) with position feedback, start a “Position Error” timer whenever the position feedback differs from the required position command by more than a setpoint error when the LSR is in REMOTE:
    - 1) For analog modulating devices, error is determined by position feedback differing from position command by more than the setpoint error.

- 2) For discrete modulating devices, error is determined by feedback not changing in the correct direction, or changing at less than a setpoint rate, when the OPEN or CLOSE PLC output is active.
- 3) Initially set the "Position Error" time to 60 seconds.
- 4) If the LSR position does not change, and position error stays outside of the setpoint error through the "Position Error" time period:
  - a) Hold position output.
  - b) Place the device in a "Failed" state.
  - c) Generate a "Position Fail" alarm.
- e. Provide separate time delay settings for each function and for each device.
- f. If the valve position inputs indicate an impossible state (i.e., valve open and closed at the same time), place the device in a "Failed" state and generate an "Illegal State" alarm.
- g. Re-establish PLC control of a device in a "Failed" state only after one of the following:
  - 1) An operator acknowledges the fault from PCS.
- h. For all alarm conditions, control other devices (as stopping pumps, etc.) as stated in the individual loop descriptions to make the system safe.
- i. For discrete modulating valves (valves positioned to intermediate positions to control process values through discrete OPEN and CLOSE outputs), count the number of actuations (OPEN or CLOSE commands) in the PLC:
  - 1) Display count on the HMI.
  - 2) Provide a reset function for the count.

### 3.02 SPECIFIC CONTROL STRATEGIES

- A. Cell 3 Gate monitoring and control:
  1. Monitor Hydraulic Actuator Control Panel Status.
    - a. Monitor and alarm for all communication faults.
    - b. Monitor status of Cell 3 Gate.
    - c. Report Open/Close status of Cell 3 Gate.
    - d. Generate an alarm if Gate has been initiated to open or close and positive.
    - e. Monitor running status of Hydraulic Pump.
  2. Create an Interlock between Existing Hydraulic Pump and New Hydraulic Pump to prevent both from running at the same time.
  3. Match all other existing controls and monitoring points of the Cell 1 and 2 hydraulic unit.
- B. Cell No. 3 Level Transmitter:
  1. Provide Level reading of Cell No. 3.
  2. Provide Volume reading of Cell No. 3.
  3. Provide Alarm set point for both High level and Low level.
  4. Provide Pump shut down signal on Low Level for both pumps.
- C. As specified in Section 40\_61\_00.

### **3.03 DEMONSTRATION AND TRAINING**

- A. As specified in Section 40\_61\_00.

## **PART 4 MEASUREMENT**

### **4.01 METHOD OF MEASUREMENT**

- A. No separate measurement shall be made for work under this Section.

## **PART 5 PAYMENT**

### **5.01 METHOD OF PAYMENT**

- A. No separate payment will be made for work under this Section. The cost of the work described in this Section shall be included in the applicable lump sum bid item.

END OF SECTION



## SECTION 40\_67\_01

### CONTROL SYSTEMS: PANELS, ENCLOSURES, AND PANEL COMPONENTS

#### PART 1 GENERAL

##### 1.01 SUMMARY

- A. Section includes:
  - 1. Design, fabrication and assembly of all instrumentation enclosures, control panels and components provided under this contract, including but not limited to:
    - a. Custom built instrumentation and control panels, including all enclosures for hand stations controllers, low voltage power distribution and marshalling panels.
    - b. Control panels furnished as part of equipment systems specified in other Divisions, such as vendor control panels (VCPs) and chemical feed panels.
    - c. Control components.
    - d. Control panel installation.
- B. Related sections:
  - 1. Section 26\_05\_00 - Common Work Results for Electrical.
  - 2. Section 26\_05\_53 - Identification for Electrical Systems.
  - 3. Section 26\_28\_01 - Low Voltage Molded Case Circuit Breakers.
  - 4. Section 40\_61\_00 - Common Work Results for Process Control and Instrumentation Systems.
- C. Provide all control panels identified in Contract Documents.

##### 1.02 REFERENCES

- A. As specified in Section 40\_61\_00.
- B. Institute of Electrical and Electronics Engineers (IEEE):
  - 1. C62.41.1 - Guide on the Surge Environment in Low-Voltage (1000 V and less) AC Power Circuits.
- C. Underwriters Laboratories Inc. (UL):
  - 1. 508 - Standard for Industrial Control Equipment.
  - 2. 508A - Standard for Industrial Control Panel.
  - 3. 1283 - Standard for Electromagnetic Interference Filters.
  - 4. 1449 - Standard for Surge Protective Devices.

##### 1.03 DEFINITIONS

- A. As specified in Section 40\_61\_00.



- B. Specific definitions:
  - 1. The term “panel” in this Section is interchangeable with the term “enclosure.”

#### 1.04 SYSTEM DESCRIPTION

- A. Panel dimensions:
  - 1. Minimum dimensions are scalable from or as indicated on the Drawings and are based upon manufacturer’s non-certified information. It is the responsibility of the Contractor or manufacturer to design and size all panels:
    - a. Size panels to provide space for all equipment, wiring, terminations, and other items in the panel, including space for future build out.
    - b. Panel sizes that substantially deviate (within 3 inches in any dimension) from the sizes indicated on the Drawings must be approved by the Engineer.
    - c. Maximum panel depth: 30 inches, unless otherwise indicated.
- B. Structural design:
  - 1. Completed and installed panel work shall safely withstand seismic requirements at the project site as specified in Section 26\_05\_00. Enclosures and internal equipment shall be braced to prevent damage from specified forces.

#### 1.05 SUBMITTALS

- A. Provide submittals as specified in Section 40\_61\_00.
- B. Provide a control panel hardware submittal for each control panel and enclosure being provided on this project, including but not limited to:
  - 1. Product data:
    - a. Enclosure construction details and NEMA type.
    - b. Manufacturer's literature and specification data sheets for each type of equipment to be installed within or on the panel or enclosure.
  - 2. Shop drawings:
    - a. Scaled, detailed exterior panel (front and side views) and interior panel layout showing equipment arrangement and dimensional information:
      - 1) Provide draft for review and approval by Engineer. The Engineer has the authority to substantially alter initial panel layouts.
    - b. Complete nameplate engraving schedule.
    - c. Structural details of fabricated panels.
  - 3. Calculations:
    - a. Provide installation details based on calculated shear and tension forces:
      - 1) Calculations shall be signed and sealed by a Professional Engineer licensed in the state where the cabinets and panels will be installed.
    - b. For assembled enclosures and other equipment with a weight of 200 pounds or more, provide calculations for:
      - 1) Weight including panel internal components.
      - 2) Seismic forces and overturning moments.

- 3) Shear and tension forces in connections.
- c. Cooling calculations, including but not limited to:
  - 1) Highest expected ambient temperature for the enclosure's location.
  - 2) Internal heat load.
  - 3) Exposure to direct sunlight.
  - 4) Dimensions of the enclosure in inches.
  - 5) Maximum allowable temperature inside the enclosure, based on the lowest operating temperature limit of the installed components.
- C. Seismic design:
  1. Seismic panel construction:
    - a. Seismic anchorage: Provide seismic design calculations and installation details for anchorage of all panels, enclosures, consoles, etc. to meet seismic requirements:
      - 1) Stamped by a Professional Engineer registered in the state where the project is being constructed.
    - b. For floor-mounted freestanding panels weighing 200 pounds or more (assembled, including contents), submit calculations, data sheets, and other information to substantiate that panel, base, and framing meet minimum design strength requirements and seismic requirements. Calculations shall be signed and sealed by a Professional Engineer licensed in the state where the cabinets and panels will be installed.

## 1.06 QUALITY ASSURANCE

- A. As specified in Section 40\_61\_00.
- B. Assemble panels, enclosures, and rack systems along with all internal and external devices, wiring, equipment, and materials in a facility that is recognized by UL to assemble and certify UL-labeled control panels:
  1. Provide all components and equipment with UL 508 listing.
  2. All control panels shall be UL 508A labeled, unless the equipment in the panel and the design in the contract documents cannot be reasonably modified to meet the requirements for UL 508A labeling:
  3. Provide fuses for all equipment that is not UL or UR listed.

## 1.07 DELIVERY, STORAGE, AND HANDLING

- A. Project environmental conditions as specified in Section 40\_61\_00.
  1. Provide instruments suitable for the installed site conditions including, but not limited to, material compatibility, site altitude, site seismic conditions, humidity, and process and ambient temperatures.

## 1.08 PROJECT OR SITE CONDITIONS

- A. As specified in Section 40\_61\_00.

## 1.09 WARRANTY

- A. As specified in Section 40\_61\_00.

## PART 2 PRODUCTS

### 2.01 MANUFACTURERS

- A. As listed below in the individual component paragraphs.
- B. Provide instruments and other components performing similar functions of the same type, model, or class, and from 1 manufacturer.

### 2.02 EXISTING PRODUCTS

- A. Provide labor and materials for complete modifications to existing panels as required.
- B. Field cut and refinish existing panel faces to original condition to accommodate installation of new instruments, removal of existing instruments, and fitting of blanks to suit new layouts. New instrument supports shall be provided as required for complete installation.

### 2.03 MATERIALS

- A. Construct and finish enclosures using materials capable of withstanding the mechanical, electrical, and thermal stresses, as well as the effects of humidity and corrosion that are likely to be encountered in normal service:
  - 1. Enclosures shall have the following properties:
    - a. NEMA Type 1: Steel.
    - b. NEMA Type 4: Steel with gasketed door, raintight.
    - c. NEMA Type 4X: Type 316 stainless steel (unless Type 304 is indicated on the Drawings).
    - d. NEMA Type 4X: Polycarbonate or fiberglass reinforced polyester (FRP) in corrosive areas where stainless steel is incompatible.
    - e. NEMA Type 12: Steel with gasketed door, dusttight.
    - f. NEMA Type 7: Cast aluminum.
- B. Bolting material:
  - 1. Commercial quality 1/2-inch diameter, stainless steel hex-head Grade 5 bolts, nuts, and washers, with unified coarse (UNC) threads.
  - 2. Carriage bolts for attaching end plates.
  - 3. All other bolted joints shall have S.A.E. standard lock washers.

## 2.04 MANUFACTURED UNITS

### A. Panels/enclosures:

1. Manufacturer: One of the following or equal:
  - a. Rittal.
  - b. Pentair (formerly Hoffman Engineering).
  - c. Saginaw Control & Engineering.
2. Panel assembly:
  - a. General guidelines for panel fabrication include:
    - 1) Continuous welds ground smooth.
    - 2) Exposed surfaces free of burrs and sharp edges.
    - 3) Base formed of heavy channel iron, either galvanized or powder coated, minimum 1/2-inch holes at 12-inch spacing to accommodate anchoring of freestanding enclosures to floor.
  - b. Construct enclosure and mounting panel using stretcher-level quality sheet metal having minimum thickness not less than the following sizes (U.S. Standard Gauge):

| <b>Enclosure Height<br/>(inches)</b> | <b>Minimum Enclosure<br/>Steel Thickness<br/>(gauge)</b> | <b>Minimum Back<br/>Mounting Panel<br/>Thickness (gauge)</b> |
|--------------------------------------|--|--|
| Wall-mounted up to 48                | 14   | 14   |
| Up to 57                             | 12   | 12   |
| 57 - 69                              | 12   | 10   |
| 69 - 82                              | 12, except 10 on back                                    | 10   |
| 82 or more                           | 10   | 10   |

- 1) Use heavier sheet metal to meet seismic requirements at the project site or when required due to equipment requirements.
- c. Construct supporting frame structure with angled, channeled, or folded rigid section of sheet metal, rigidly attached to and having essentially the same outer dimensions as the enclosure surface and having sufficient torsional rigidity to resist the bending moments applied via the enclosure surface when it is deflected.
- d. Provide stiffeners for back mounting panels in enclosures larger than 4 feet. In addition, secure the panels in place by collar studs welded to the enclosure.
- e. Door construction:
  - 1) Turned-back edges suitably braced and supported to maintain alignment and rigidity without sagging.
  - 2) Sufficient width to permit door opening without interference with rear projection of flush-mounted instruments.
  - 3) Heavy-gauge piano-type continuous stainless steel hinges.
  - 4) For NEMA Type 12, Type 4, and Type 4X, provide oil-resistant neoprene sealing gasket and adhesive to seal cover to enclosure.
  - 5) Gasket installed to seal against roll lip on the enclosure opening.

- f. Latches:
    - 1) For panels, provide each door with a 3-point latching mechanism and locking handle with rollers on the ends of the latch rods. Latch rods shall be connected to a common door handle, hold doors securely, and form a compressed seal between door and gasket, at the top, side, and bottom.
      - a) Provide padlock for each enclosure with padlock provisions.
    - 2) Include an oiltight key-locking, 3-point latching mechanism on each door:
      - a) Provide 2 keys per panel.
      - b) All locks keyed alike.
    - 3) For large NEMA Type 4 and NEMA Type 4X cabinets not available with 3-point latching hardware, provide multiple clips and padlock hasps.
  - g. Panel cut-outs:
    - 1) Cut, punch, or drill cutouts for instruments, devices, and windows. Smoothly finish with rounded edges.
    - 2) Allow a minimum of 3-inch envelope around all displays, controllers, and monitors.
    - 3) Reinforce around cut-outs with steel angles or flat bars for the following:
      - a) Large panel cutouts; for example, openings for local operator interfaces.
      - b) Pilot device groupings, where the removed metal exceeds 50 percent of the available metal.
  - 3. In addition to the requirements specified above, the following requirements for NEMA Type 4X powder coated stainless steel enclosures apply:
    - a. Minimum 14-gauge, Type 304 stainless steel.
    - b. Captive stainless steel cover screws threaded into sealed wells.
    - c. Inside finish: White polyester powder coating.
    - d. Specifically designed for use with flange-mounted disconnect handles where required or as indicated on the Drawings.
    - e. NEMA Type 4X powder-coated stainless steel enclosures are not an acceptable substitute for stainless steel unless indicated on the Drawings.
  - 4. Outdoor panels. Supplementary requirements for panels located outdoors are as follows:
    - a. All enclosures located outdoors shall be explicitly designed and rated for outdoor service by the manufacturer.
    - b. Door hardware: Stainless steel.
    - c. Provide factory installed rain canopy and sun shield for all enclosures with operator interface panels.
    - d. Bases: Heavy channel, gasketed stainless steel bases, flanges up, for anchoring to pad.
- B. Arrangement of components:
- 1. Arrange panel internal components for external conduit and piping to enter into panel either from above or below.

2. Arrange panel instruments and control devices in a logical configuration, associating pushbutton and selector switches with related readout devices, or as indicated on the Drawings.
  3. Mount internal control components on an internal back panel. Devices may be mounted on the side panel only by special permission from the Engineer.
  4. All control-panel-mounted operator interface devices shall be mounted between 3 feet and 5 feet above finished floor.
- C. Overcurrent protection:
1. Main overcurrent device:
    - a. Where the electrical power supply voltage to the control panel is more than 120 VAC, provide the panel with a flange-mounted disconnect handle operating a molded-case circuit breaker and provide a control power transformer for 120-VAC circuits:
      - 1) Door-mounted disconnect handles are not acceptable.
      - 2) Mechanically interlock the disconnect switch with the control enclosure doors so that no door can be opened unless the power is disconnected, and the disconnect switch cannot be closed until all doors are closed.
      - 3) Provide means to defeat the interlock.
      - 4) Lockable in the off position.
    - b. Control panels supplied with 120 VAC:
      - 1) Provide an internal breaker with the line side terminals covered by a barrier.
      - 2) Provide a nameplate prominently positioned on the control panel identifying the location of the power source and a warning statement requiring the source to be disconnected before opening the door to the enclosure.
  2. Provide circuit breakers as specified in Section 26\_28\_01.
  3. Selection and ratings of protective devices:
    - a. Interrupting ratings: Not less than the system maximum available fault current at the point of application.
    - b. Voltage rating: Not less than the voltage of the application.
    - c. Select current rating and trip characteristics to be suitable for:
      - 1) Maximum normal operating current.
      - 2) Inrush characteristics.
      - 3) Coordination of the protective devices to each other and to the source breaker feeding the panel.
  4. Provide a separate protective device for each powered electrical device:
    - a. An individual circuit breaker for each 120-VAC instrument installed within its respective control panel and clearly identified for function.
    - b. An individual fuse for each PLC discrete output. Provide with individual blown fuse indication external of the I/O card:
      - 1) Size external fuse to open before any I/O-card-mounted fuses.
      - 2) Individual discrete inputs shall use a 0.5-ampere fuse.
    - c. Control loops can use individual 5-ampere fuse for the loop.

- d. Install protective devices on the back mounting panel and identify by a service nameplate in accordance with the wiring diagrams.
  5. Fuses for 4 to 20 milliamperes signals:
    - a. Provide durable, readily visible label for each fuse, clearly indicating the correct type, size, and ratings of replacement fuse:
      - 1) Label shall not cover or interfere with equipment manufacturer's instructions.
    - b. An individual 1/2-ampere fuse for each 4 to 20 milliamperes analog loop powered from the control panel.
    - c. Provide fuses rated for the voltage and available short-circuit current at which they are applied.
    - d. Manufacturer: One of the following or equal:
      - 1) Ferraz Shawmut.
      - 2) Littelfuse.
      - 3) Bussmann.
  6. Fuse holders:
    - a. Modular type:
      - 1) DIN rail mounting on 35-millimeter rail.
      - 2) Touch-safe design: All connection terminals to be protected against accidental touch.
      - 3) Incorporates blown-fuse indicator.
      - 4) Plug-in style fuse terminals and fuse plugs are not acceptable.
    - b. Provide nameplate identifying each fuse:
      - 1) As specified in Section 26\_05\_53.
    - c. Manufacturer: One of the following or equal:
      - 1) Phoenix Contact.
      - 2) Allen-Bradley 1492-FB Series B.
  7. Control circuit breakers:
    - a. DIN rail mounting on 35-millimeter rail.
    - b. Manual OPEN-CLOSE toggle switch.
    - c. Rated for 250 VAC.
    - d. Interrupting rating: 10 kiloampere (kA) or available fault current at the line terminal, whichever is higher.
    - e. Current ratings: As indicated on the Drawings or as required for the application.
    - f. Provide nameplate identifying each circuit breaker:
      - 1) As specified in Section 26\_05\_53.
    - g. Manufacturer: One of the following or equal:
      - 1) Phoenix Contact.
      - 2) ABB.
      - 3) Allen-Bradley.
      - 4) Square D.
- D. Conductors and cables:
1. Power and control wiring:
    - a. Materials: Stranded, soft annealed copper.
    - b. Insulation: 600 volts type MTW.

- c. Minimum sizes:
  - 1) Primary power distribution: 12 AWG.
  - 2) Secondary power distribution: 14 AWG.
  - 3) Control: 16 AWG.
- d. Color:
  - 1) AC power (line and load): Black.
  - 2) AC power (neutral): White.
  - 3) AC control: Red.
  - 4) AC control: Orange for foreign voltages.
  - 5) DC power and control (ungrounded): Blue.
  - 6) DC power and control (grounded): White with Blue stripe.
  - 7) Ground: Green.
- 2. Signal cables:
  - a. Materials: Stranded, soft annealed copper.
  - b. Insulation: 600 volts, PVC outer jacket.
  - c. Minimum size: 18 AWG paired triad.
  - d. Overall aluminum shield (tape).
  - e. Copper drain wire.
  - f. Color:
    - 1) 2-Conductor:
      - a) Positive (+): Black.
      - b) Negative (-): White and red.
    - 2) 3-Conductor:
      - a) Positive (+): Black.
      - b) Negative (-): Red.
      - c) Signal: White.
  - g. Insulate the foil shielding and exposed drain wire for each signal cable with heat-shrink tubing.
- E. Conductor identification:
  - 1. Identify each conductor and cable with unique wire numbers as specified in Section 26\_05\_53.
  - 2. Readily identified without twisting the conductor.
- F. General wiring requirements:
  - 1. Wiring methods: Wiring methods and materials for panels shall be in accordance with the NEC requirements for General Purpose (no open wiring) unless otherwise specified.
  - 2. Install all components in accordance with the manufacturer's instructions included in the listing and labeling.
  - 3. Provide a nameplate on the cover of the control panel identifying all sources of power supply and foreign voltages within the control panel.
  - 4. Provide transformers, protective devices, and power supplies required to convert the supply voltage to the needed utilization voltage.
  - 5. Provide power surge protection for all control panels.



6. Provide signal surge protection within control panels for each analog I/O, discrete I/O, and data line (Copper Ethernet, Coax, Fieldbus signals) that originates from outdoor devices.
  7. Provide non-metallic ducts for routing and organization of conductors and cables:
    - a. Provide wiring separation plan.
    - b. Size ducts for ultimate build-out of the panel, or for 20-percent spare, whichever is greater.
    - c. Provide separate ducts for signal and low-voltage wiring from power and 120-VAC control wiring:
      - 1) 120 VAC: Grey colored ducts.
      - 2) 24 VDC: White colored ducts.
  8. Cables shall be fastened with cable-mounting clamps or with cable ties supported by any of the following methods:
    - a. Screw-on cable tie mounts.
    - b. Hammer-on cable-tie mounting clips.
    - c. Fingers of the nonmetallic duct.
  9. Wire Ties:
    - a. No wire ties inside wire duct.
    - b. Use Panduit Cable tie installation tool, with tension control/cutoff.
    - c. Verify cut ends are cut flush filed smooth after installed.
  10. Provide supports at the ends of cables to prevent mechanical stresses at the termination of conductors.
  11. Support panel conductors where necessary to keep them in place.
  12. Wiring to rear terminals on panel-mount instruments shall be run in nonmetallic duct secured to horizontal brackets run adjacent to the instruments.
  13. Conductors and cables shall be run from terminal to terminal without splice or joints. Exceptions:
    - a. Factory-applied connectors molded onto cables shall be permitted. Such connectors shall not be considered as splices or joints.
  14. The control panel shall be the source of power for all 120-VAC devices interconnected with the control panel including, but not limited to:
    - a. Solenoid valves.
    - b. Instruments both mounted in the control panel and remotely connected to the control panel.
- G. Provide power circuits for all Contractor and Vendor-furnished PLC cabinets in accordance with the PLC and Instrument Power wiring diagrams Indicated on the Drawings or as specified.

## 2.05 COMPONENTS

- A. Thermal management:
1. Provide heating, cooling, and dehumidifying devices in order to maintain all instrumentation and control devices to within a range as specified in Section 40\_61\_00.

2. Air conditioner:
  - a. Provide solid-state cabinet coolers or air conditioning units on all outdoor panels containing electronic components such as local operator interface (LOI) units, panel instruments, programmable logic controllers, or remote I/O.
  - b. Provide filters on intake and exhaust openings.
  - c. Increase panel sizes as needed to accommodate cooling units.
  - d. Enclosure rating: NEMA Type 4X.
  - e. Manufacturer: The following or equal:
    - 1) Kooltronic Integrity Series 21.
3. Heating:
  - a. Provide all panels located in areas that are not climate controlled with thermostatically controlled strip heaters, except where all of the following conditions apply:
    - 1) The panel is not supplied with 120 VAC power.
    - 2) There are no electronics or moisture-sensitive devices in the enclosure.
    - 3) The panel is smaller than 38 inches high.
4. Heat exchanger:
  - a. Closed-loop design ensuring separation of ambient air and clean air inside the cabinet.
  - b. Filterless design to facilitate easy cleaning of the core.
  - c. Mounting: As indicated on the Drawings.
  - d. Manufacturer: The following or equal:
    - 1) Noren CC Series.
5. Enclosure temperature sensor as indicated on the Drawings:
  - a. Provide wall-mounted RTD transmitter (to measure internal cabinet temperature) in all enclosures containing electrical components such as PLCs, RTUs, RIO, and VFDs.
  - b. Platinum RTD.
  - c. 4-20 mA DC output.
  - d. Sensor and electronic enclosure.
  - e. Accuracy: Within 2 degrees Fahrenheit.
  - f. Manufacturer: One of the following or equal:
    - 1) Omega EWS Series.
    - 2) TCS Basys Controls TS Series as indicated on the Drawings.
6. Enclosure temperature switch:
  - a. Provide wall-mounted bimetallic switch transmitter (to measure internal cabinet temperature in all enclosures) containing electrical components such as PLCs, RTUs, RIO, and VFDs.
  - b. Sensor and electronic enclosure.
  - c. Accuracy: Within 2 degrees Fahrenheit.
  - d. Manufacturer: The following or equal:
    - 1) Hoffman ATEMNC.
    - 2) Pfannenbergl FLZ.

7. Status relays and discrete inputs for switches, power supplies, and fieldbus devices (if applicable):
    - a. Provide as indicated on the Drawings or as specified.
  8. Fan ventilation:
- B. Panel meters:
1. Pointer type:
    - a. Suitable for panel mounting.
    - b. Minimum scale length: 3 inches.
    - c. Calibrated in engineering units.
    - d. Accuracy: Within 2 percent of span.
    - e. NEMA Type 4/IP65 sealed front metal bezel.
    - f. Manufacturer: The following or equal:
      - 1) Yokogawa.
      - 2) Red Lion.
  2. Digital process indicators:
    - a. General:
      - 1) Integral provisions for scaling.
      - 2) Scale to process engineering units.
      - 3) Switch-programmable decimal points.
      - 4) NEMA Type 4/IP65 sealed front bezel.
    - b. Current and voltage indicators:
      - 1) 3-1/2-digit minimum.
      - 2) Minimum character height: 0.5 inches.
      - 3) Accuracy:
        - a) AC/DC volts: Within 0.1 percent of reading plus 2 digits.
        - b) DC current: 4 to 20 milliamperes; within 0.1 percent of reading plus 1 digit.
        - c) DC voltage: 0 to 10 volts; within 0.1 percent of reading plus 1 digit.
    - c. Operating voltage: 120 VAC.
    - d. Operating temperature: 0 to 60 degrees Celsius.
      - 1) Manufacturer: One of the following or equal:
        - a) Red Lion.
        - b) Action Instruments Visipak.
  3. Digital bar graph meter:
    - a. Self-contained instruments that display process signals directly in engineering units, both in decimal format and as a bar graph display.
    - b. Suitable for panel mounting.
    - c. LED display:
      - 1) Not less than 3 decimal digits.
      - 2) Not less than a 101-segment LED bar graph.
    - d. Input signal:
      - 1) All conventional current loops and voltage control signals.
    - e. Minimum sample rate of once per second.
    - f. Provisions for field-adjustable scaling and/or offset.
    - g. Accuracy shall be within 1 least-significant digit.

- h. Manufacturer: One of the following or equal:
            - 1) Ametek Dixon.
            - 2) Yokogawa.
            - 3) Weschler Instruments.
    - 4. Counters:
      - a. 6 digits.
      - b. Switch-selectable inputs:
        - 1) Switch contacts.
        - 2) CMOS.
        - 3) TTL.
        - 4) Magnetic pickup.
        - 5) RLC sensors.
      - c. Selectable up/down control via external signal.
      - d. Remote reset.
      - e. Remote inhibit to prevent accumulating counts.
      - f. Programmable to enable or disable front panel reset.
      - g. Non-volatile memory to retain all data upon loss of supply power.
      - h. Sunlight readable.
      - i. Operating temperature: 0 to 50 degrees Celsius.
      - j. Manufacturer: The following or equal:
        - 1) Red Lion PAX Series.
- C. Pilot devices:
  - 1. General:
    - a. Provide operator pushbuttons, switches, and pilot lights, from a single manufacturer.
    - b. Size:
      - 1) 30.5 millimeters.
    - c. Heavy duty.
    - d. Pushbuttons:
      - 1) Contacts rated:
        - a) NEMA Type A600.
      - 2) Furnish 1 spare normally open contact and normally closed contact with each switch.
    - e. Selector switches:
      - 1) Contacts rated:
        - a) NEMA Type A600.
        - b) Knob type.
      - 2) Furnish 1 spare normally open contact and normally closed contact with each switch.
      - 3) Provisions for locking in the OFF position where lockout provisions are indicated on the Drawings.
    - f. Pilot lights:
      - 1) Type:
        - a) LED for interior installations.
      - 2) Push to test.

- 3) Lamp color:
  - a) On/Running/Start: Red.
  - b) Off/Stop: Green.
  - c) Power: White.
  - d) Alarm: Amber.
  - e) Status or normal condition: White.
  - f) Opened: Red.
  - g) Closed: Green.
  - h) Failure: Red.
2. Indoor and outdoor areas:
  - a. NEMA Type 4/13.
  - b. Manufacturer: One of the following or equal:
    - 1) Allen-Bradley Type 800T.
    - 2) Square D Class 9001, Type K.
    - 3) General Electric Type CR104P.
    - 4) IDEC TWTD Series.
  3. Corrosive areas:
    - a. NEMA Type 4X.
    - b. Corrosion resistant.
    - c. Exterior parts of high-impact strength fiberglass-reinforced polyester or multiple-layer epoxy-coated zinc.
    - d. Manufacturer: One of the following or equal:
      - 1) Cutler Hammer Type E34.
      - 2) Square D Class 9001, Type SK.
      - 3) Allen-Bradley Type 800H.
      - 4) IDEC TWTD Series.
  4. Hazardous (Classified) Areas/Class I Division 2:
    - a. NEMA Type 4X.
    - b. Corrosion resistant.
    - c. Exterior parts of high-impact strength fiberglass-reinforced polyester or multiple-layer epoxy-coated zinc:
      - 1) All contacts contained within a hermetically sealed chamber:
        - a) Pushbuttons.
        - b) Selector switches.
        - c) Push-to-test contacts on pilot lights.
      - 2) UL listed and labeled for Class I Division 2 areas.
    - d. Manufacturer: One of the following or equal:
      - 1) Cutler Hammer Type E34.
      - 2) Allen-Bradley Type 800H.

D. Potentiometer and slidewire transmitters:

  1. Provide a DC output in proportion to a potentiometer input.
  2. Potentiometer input:
    - a. 100 ohms to 100 K ohms.
    - b. Impedance Greater or equal to 1 M ohms.
    - c. Zero turn-up: 80 percent of full-scale input.
    - d. Span turn-down: 80 percent of full-scale input.

3. Field-configurable output:
    - a. Voltage and current: All conventional current loops and voltage control signals.
  4. Accuracy including linearity and hysteresis within 0.1 percent maximum at 25 degrees Celsius.
  5. Operating temperature: 0 to 55 degrees Celsius.
  6. Supply power: 9 to 30 VDC.
  7. Manufacturer: The following or equal:
    - a. Phoenix Contact.
- E. Signal isolators and converters:
1. Furnish signal isolators that provide complete isolation of input, output, and power input:
    - a. Minimum isolation level: 1.5 kilovolts AC/50 Hertz for at least 1 minute.
    - b. Adjustable span and zero.
    - c. Accuracy: Within 1.0 percent of span.
    - d. Ambient temperature range: -20 to +65 degrees Celsius.
  2. Manufacturer: One of the following or equal:
    - a. Phoenix Contact MCR Series.
    - b. Acromag 1500, 600T, 800T, Flat Pack, or ACR Series.
    - c. Action Instruments Q500 Series or Ultra SlimPakII.
    - d. AGM Electronics Model TA-4000.
- F. Relays:
1. General:
    - a. For all types of 120-VAC relays, provide surge protection across the coil of each relay.
    - b. For all types of 24-VDC relays, provide a free-wheeling diode across the coil of each relay.
  2. General purpose:
    - a. Magnetic control relays.
    - b. NEMA Type A300 rated:
      - 1) 300 volts.
      - 2) 8 Amps continuous (minimum).
      - 3) 7,200 volt-amperes make.
      - 4) 720 volt-amperes break.
    - c. Plug-in type.
    - d. LED indication for energization status.
    - e. Coil voltages: As required for the application.
    - f. Minimum poles: DPDT.
    - g. Touch-safe design: All connection terminals to be protected against accidental touch.
    - h. Enclose each relay in a clear plastic heat and shock-resistant dust cover.
    - i. Quantity and type of contact shall be as indicated on the Drawings or as needed for system compatibility.
    - j. Relays with screw-type socket terminals.

- k. Provide additional (slave/interposing) relays when the following occurs:
  - 1) The number or type of contacts shown exceeds the contact capacity of the specified relays.
  - 2) Higher contact rating is required in order to interface with starter circuits or other equipment.
- l. DIN rail mounting on 35-millimeter rail.
- m. Ice-cube-type relays with retainer clips to secure relay in socket.
- n. Integrated label holder for device labeling.
- o. Manufacturer: One of the following or equal:
  - 1) Phoenix Contact PLC Series.
  - 2) Potter and Brumfield Type KRP or KUP.
  - 3) IDEC R\* Series (\* = H, J, R, S, U).
  - 4) Allen-Bradley Type 700 HC.
  - 5) Square D Type K.
- 3. Latching:
  - a. Magnetic-latching control relays.
  - b. NEMA Type B300 rated:
    - 1) 300 volts.
    - 2) 10 Amps continuous.
    - 3) 3,600 volt-amperes make.
    - 4) 320 volt-amperes break.
  - c. Plug-in type.
  - d. DIN rail mounting on 35-millimeter rail.
  - e. Coil voltage: As required for the application.
  - f. Minimum poles: 2 PDT; as required for the application. Plus 1 spare pole.
  - g. Touch-safe design: All connection terminals to be protected against accidental touch.
  - h. Clear cover for visual inspection.
  - i. Provide retainer clip to secure relay in socket.
  - j. Manufacturer: One of the following or equal:
    - 1) Square D 8501, Type K.
    - 2) IDEC TWTD Series.
- 4. Time delay:
  - a. Provide time-delay relays to control contact transition time.
  - b. Contact rating:
    - 1) 240 volts.
    - 2) 10 Amps continuous.
    - 3) 3,600 volt-amperes make.
    - 4) 360 volt-amperes break.
  - c. Coil voltage: As required for the application.
  - d. Provide pneumatic or electronic type with on-delay, off-delay, and on/off-delay:
    - 1) For off-delay, use true power-off time-delay relays. Where the required timing range exceeds capability of the off-delay relay use, signal off-delay where power loss will not cause undesirable operation or pneumatic time-delay relays.

- e. Minimum poles: 2 PDT.
  - f. Units include adjustable dial with graduated scale covering the time range in each case.
  - g. Minimum timing range: 0.1 seconds to 10 minutes, or as required for the application.
  - h. Manufacturer: One of the following or equal:
    - 1) IDEC RTE Series.
    - 2) Agastat Series 7000 (pneumatic).
    - 3) Allen-Bradley Type 700-HR.
- G. Terminal blocks:
- 1. DIN rail mounting on 35-millimeter rail.
  - 2. Suitable for specified AWG wire.
  - 3. Rated for 15 amperes at 600 volts.
  - 4. Screw terminal type.
  - 5. Provide mechanism to prevent wire connection from loosening in environments where vibration is present. This mechanism shall not cause permanent deformation to the metal body.
  - 6. Finger-safe protection for all terminals for conductors.
  - 7. Construction: Polyamide insulation material capable of withstanding temperature extremes from - 40 to 105 degrees Celsius.
  - 8. Terminals: Plainly identified to correspond with markings on the diagrams:
    - a. Permanent machine-printed terminal identification.
  - 9. Disconnect-type field signal conductor terminals with socket/screw for testing.
  - 10. Identify terminals suitable for use with more than 1 conductor.
  - 11. Position:
    - a. So that the internal and external wiring does not cross.
    - b. To provide unobstructed access to the terminals and their conductors.
  - 12. Provide minimum 25-percent spare terminals.
  - 13. Manufacturer: One of the following or equal:
    - a. Phoenix Contact UT4 Series.
    - b. Allen-Bradley 1492 Series.
- H. Wire duct:
- 1. Provide flame retardant plastic wiring duct, slotted with dust cover.
  - 2. Type:
    - a. Wide slot.
    - b. Narrow slot.
    - c. Round hole.
  - 3. Manufacturer: The following or equal:
    - a. Panduit.
- I. Din Rail:
- 1. Perforated Steel.
  - 2. 35mm width.
  - 3. 15mm deep.



4. Provide 2 inch offset using one of the following:
  - a. Offset brackets.
  - b. Preformed standoff Din Rail Channel.
  
- J. Surge protection devices:
  1. Control panel power:
    - a. 120-volt control power source: Non-UPS powered:
      - 1) Provide surge protection device (SPD) for panel power entrances:
        - a) Nominal 120-VAC with a nominal clamping voltage of 200 volts.
        - b) Non-faulting and non-interrupting design.
        - c) A response time of not more than 5 nanoseconds.
      - 2) Control panel power system level protection, non-UPS powered:
        - a) Designed to withstand a maximum 10-kA test current of a 8/20  $\mu$ s waveform according to IEEE C62.41.1 Category C Area.
        - b) For panels receiving power at 120 VAC, provide surge protection at secondary of main circuit breaker.
        - c) Provide both normal mode noise protection (line to neutral) and common mode (neutral to ground) surge protection.
        - d) DIN rail mounting.
        - e) Attach wiring to the SPD by means of a screw-type cable-clamping terminal block:
          - (1) Gastight connections.
          - (2) The terminal block: Fabricated of non-ferrous, non-corrosive materials.
        - f) Visual status indication of MOV status on the input and output circuits.
        - g) Dry contact rated for at least 250 VAC, 1 Amp for remote status indication.
        - h) Meeting the following requirements:
          - (1) Response time: Less than or equal to 100 ns.
          - (2) Attenuation: Greater than or equal to -40 dB at 100 kilovolt-Hertz as determined by a standard 50-ohm insertion test.
          - (3) Safety approvals:
            - (a) UL 1283 (EMI/RFI Filter).
            - (b) UL 1449 2nd Edition.
        - i) Manufacturer: One of the following or equal:
          - (1) Phoenix Contact Type SFP Filter.
          - (2) Liebert Accuvar Series.
          - (3) Islatrol.
      - b. 120-volt control power source: UPS powered.
        - 1) Provide surge protection on the control power source at each panel containing power supplies, or electronic components including PLCs, I/O, HMI, and digital meters.

- 2) Location:
    - a) For panels with a UPS, install surge protection ahead of UPS and maintenance bypass switch.
      - (1) Surge protection is not required for 120-VAC circuits that are only used for panel lights and receptacles.
    - b) For panels receiving power at 480 VAC, provide surge protection on the 120-VAC control power transformer secondary.
  - 3) MCOV: 150 VAC.
  - 4) Surge capability (8/20  $\mu$ s wave): 10 kA.
  - 5) Peak let-through: 620V L-N, 850V L-G.
  - 6) Manufacturer: One of the following or equal:
    - a) Phoenix Contact Plugtrab PT Series.
    - b) MTL Surge Technologies MA15 Series.
2. Instrument, data, and signal line protectors (traditional I/O) – panel mounted:
    - a. Surge protection minimum requirements: Withstand a 10-kA test current of a 8/20  $\mu$ s waveform in accordance with IEEE C62.41.1 Category C Area.
    - b. DIN rail mounting on 35-millimeter rail (except field-mounted SPDs).
    - c. SPDs consisting of 2 parts:
      - 1) A base terminal block.
      - 2) A plug protection module:
        - a) Replacing a plug shall not require the removal of any wires nor interrupt the signal.
        - b) Base and plug coded to accept only the correct voltage plug.
    - d. SPD manufacturer: One of the following or equal:
      - 1) Phoenix Contact Plugtrab Series.
      - 2) Bournes Series 1800.
  3. Instrument, data, and signal line protectors (traditional I/O) – field mounted:
    - a. Surge protection minimum requirements: Withstand a minimum 10-kA test current of a 8/20  $\mu$ s waveform in accordance with IEEE C62.41.1 Category C Area.
    - b. Manufacturer: One of the following or equal:
      - 1) Plugtrab PT Series.
      - 2) MTL TP48 Series.
  4. Fieldbus network protectors: Panel mounted:
    - a. DeviceNet network surge protectors:
      - 1) Manufacturer: One of the following or equal:
        - a) Phoenix Contact Trabtech MCR-Plugtrab PT PE/S+1x2-BE header with PT PE/S+1x2-24-ST plug.
        - b) Transtector Systems Inc. DN-24 Series.
      - 2) Nominal operating voltage: 24 VDC.
      - 3) Maximum continuous operating voltage: 35 VDC.
      - 4) Shall withstand a surge current (8/20  $\mu$ s combination wave) of 700 amperes.
      - 5) Operating temperature range: -40 to 85 degrees Celsius.

- b. PROFIBUS surge protectors:
    - 1) PROFIBUS DP:
      - a) Manufacturer: The following or equal:
        - (1) Phoenix Contact PT 1x2+F-BE series base module with PT 3-PB Series protection module.
      - b) Nominal voltage: 5 VDC.
      - c) Maximum continuous operating voltage: 5.2 VDC.
      - d) Nominal current: 450 milliamperes.
      - e) Nominal discharge surge current: 10 kA.
      - f) Voltage protection level at 1 kilovolt per micro-second: 55 volts.
      - g) Shall withstand a maximum discharge surge current (8/20 micro second combination wave) of 10 kA.
      - h) Operating temperature range: -40 to 85 degrees Celsius.
    - 2) PROFIBUS PA:
      - a) Manufacturer: One of the following or equal:
        - (1) Pepperl-Fuchs DP-LBF Series base and protection modules.
        - (2) ABB NGV210 Series base module with NGV211 Series protection module.
      - b) Line-line voltage protection level at 1 kilovolt per micro-second: 50 volts.
      - c) Nominal discharge surge current: 10 kA.
      - d) Shall withstand a maximum surge current (8/20 micro second combination wave) of 20 kA.
      - e) Operating temperature range: -40 to 80 degrees Celsius.
  - c. Foundation Fieldbus H1 surge protectors:
    - 1) Manufacturer: One of the following or equal:
      - a) Pepperl-Fuchs DP-LBF Series base and protection modules.
      - b) ABB NGV210 Series base module with NGV211 Series protection module.
    - 2) Line-line voltage protection level at 1 kilovolt per micro-second: 50 volts.
    - 3) Nominal discharge surge current: 10 kA.
    - 4) Shall withstand a maximum surge current (8/20 micro second combination wave) of 20 kA.
    - 5) Operating temperature range: -40 to 80 degrees Celsius.
5. Fieldbus instrument protectors - field mounted.
- a. PROFIBUS PA instruments:
    - 1) Manufacturer: One of the following or equal:
      - a) Pepperl-Fuchs F\*-LBF Series.
      - b) ABB NGV220 Series.
    - 2) Nominal discharge surge current: 10 kA.
    - 3) Line-line voltage protection level at 1 kilovolt per micro-second: 50 volts.
    - 4) Operating temperature range: -40 to 80 degrees Celsius.

- b. Foundation Fieldbus H1 instruments:
  - 1) Manufacturer: One of the following or equal:
    - a) Pepperl-Fuchs F\*-LBF Series.
    - b) ABB NGV220 Series.
  - 2) Nominal discharge surge current: 10 kA.
  - 3) Line-line voltage protection level at 1 kilovolt per micro-second: 50 volts.
  - 4) Operating temperature range: -40 to 80 degrees Celsius.
  
- K. Horns and beacons:
  - 1. Beacons/horn combination units:
    - a. Manufacturer: One of the following or equal:
      - 1) Federal Signal Multi-Status LED 108i with tone module.
      - 2) LED Colors: Red, Green, Amber.
      - 3) Power: 120VAC.
      - 4) Provide accessories such as pipe mount flange, pipe extensions, corner mount brackets, or wall mount brackets as needed.
    - b. Horn rated 80 dB minimum at 10 feet.
  - 2. Dedicated beacon unit:
    - a. Manufacturer: One of the following or equal:
      - 1) Federal Signal Corp Starfire Series.
      - 2) Allen-Bradley 855 B \*-\* 10 Series.
      - 3) Edwards 102 Series.
  - 3. Dedicated horn unit:
    - a. Electromechanical:
      - 1) Manufacturer: One of the following or equal:
        - a) Federal Signal 350 or 31X Series.
        - b) Edwards 878EX or 879EX Series.
    - b. Electronic:
      - 1) Manufacturer: One of the following or equal:
        - a) Federal Signal 300GCX or 300X Series.
        - b) Allen-Bradley 855H or 855XH Series.
        - c) Edwards 5530M or 5533MD Series.
    - c. Rated for 80 dB minimum at 10 feet.
  
- L. Power supplies:
  - 1. Design power supply systems so that either the primary or backup supply can be removed, repaired, and returned to service without disrupting the system operation.
  - 2. Convert 120 VAC to 24 volt DC or other DC voltages required or as required for the application.
  - 3. Provide backup 24 VDC power supply units to automatically supply the load upon failure of the primary supply.
  - 4. Provide power supply arrangement that is configured with several modules to supply adequate power in the event of a single module failure:
    - a. Provide automatic switchover upon module failure.
    - b. Alarm contacts monitored by the PLC.

5. Sized to provide 40-percent excess rated capacity.
  6. UL 508C listed to allow full rated output without de-rating.
  7. Provide fuse or short-circuit protection.
  8. Provide a minimum of 1 set of dry contacts configured to change state on failure for monitoring and signaling purposes.
  9. Output regulation: Within 0.05 percent for a 10-percent line change or a 50-percent load change:
    - a. With remote voltage sensing.
  10. Operating temperature range: 0 to 50 degrees Celsius.
  11. Touch-safe design: All connection terminals to be protected against accidental touch.
  12. DIN rail mounting on 35-millimeter rail.
  13. Provide self-protecting power supplies with a means of limiting DC current in case of short circuit.
  14. Manufacturer: One of the following or equal:
    - a. Fully redundant:
      - 1) Phoenix Contact Quint Power Supply with SFB technology.
        - a) Phoenix Contact Quint - O-ring redundancy module.
      - 2) IDEC PS5R Series:
        - a) Wit redundancy Diode.
    - b. Sola.
    - c. Acopian.
    - d. PULS.
- M. Limit switches:
1. NEMA Type 4X.
  2. AC contact rating 120 volts, 10 A.
  3. DC contact rating 125 volts, 0.4 A.
  4. Provide robust actuation mechanism not prone to degradation.
  5. Provide complete actuator mechanism with all required hardware.
  6. Allows for contact opening even during contact weld condition.
  7. UL approved.
  8. Operating temperature range: -18 to +110 degrees Celsius (0 to 230 degrees Fahrenheit).
  9. Manufacturer: One of the following or equal:
    - a. Allen-Bradley 802 Series.
    - b. Honeywell HDLS Series.
    - c. Omron D4 Series.
    - d. Eaton E47, E49, E50.
    - e. ABB.
- N. Current switches:
1. Operate from 120-VAC supply voltage.
  2. 1 normally open and normally closed contacts.
  3. Adjustable current setting.
  4. Manufacturer:
    - a. Zelio<sup>®</sup> RM35.

## 2.06 ACCESSORIES

- A. As specified in Section 40\_61\_00.
- B. Provide panels with an inside protective pocket to hold the panel drawings. Ship panels with 1 copy of accepted Shop Drawings including, but not limited to, schematic diagram, connection diagram, and layout drawing of control wiring and components in a sealed plastic bag stored in the panel drawing pocket.
- C. Provide 15-inch floor stands or legs where needed or as indicated on the Drawings.
- D. Provide a folding shelf for enclosures that contain programmable controllers. The shelf shall be mounted on the inside surface of the door, capable of supporting a laptop computer.
- E. Provide nameplate to each panel as indicated on the Drawings:
  - 1. Provide as specified in Section 26\_05\_53 on all internal and external instruments and devices.
  - 2. Provide a nameplate with the following markings that is plainly visible after installation:
    - a. Manufacturer's name, trademark, or other descriptive marking by which the organization responsible for the panel can be identified.
    - b. Supply voltage, phase, frequency, and full-load current.
    - c. Power source or circuit ID.
    - d. Short-circuit current rating of the panel based on one of the following:
      - 1) Short-circuit current rating of a listed and labeled assembly.
      - 2) Short-circuit current rating established utilizing an approved method.
- F. Provide a window kit where indicated on the Drawings or where a transmitter with display is mounted inside a control panel. The window shall meet the following requirements:
  - 1. Safety plate glass.
  - 2. Secured by rubber locking seal.
  - 3. Allow full viewing of devices issuing visual process data or diagnostics.
- G. Lighting:
  - 1. Provide 1 luminaire for each section, on the interior of the panel, spaced evenly along the top-front of the enclosure door opening(s):
    - a. Covered or guarded.
    - b. Provide On-Off door-activated switches where indicated on the Drawings.
    - c. 120-volt, single-phase, 15-amp style plug.
    - d. Provide 4,000 K, 900 Lumens – LED fixture.
      - 1) Provide additional fixtures for every 36 inches of width.
- H. Receptacles:
  - 1. Provide 1 duplex receptacle located every 4 feet of enclosure width, spaced evenly along the back mounting panels.
  - 2. GFCI, 120-volt, single-phase, 15-amp style plug.

3. Provide circuit breaker or fuse to limit receptacle draw to 5 amperes.
- I. Grounding:
1. Provide the following:
    - a. Grounding strap between enclosure doors and the enclosure.
    - b. Equipment grounding conductor terminals.
    - c. Provide equipment ground bus with lugs for connection of all equipment grounding wires.
    - d. Bond multi-section panels together with an equipment grounding conductor or an equivalent grounding bus.
  2. Identify equipment grounding conductor terminals with the word "GROUND," the letters "GND," the letter "G," or the color green.
  3. Signal (24 VDC) grounding: Terminate each drain wire of a signal (shielded) cable to a unique grounding terminal block, or common ground bus at the end of the cable as shown on the Loop Drawings.
  4. Ensure the continuity of the equipment grounding system by effective connections through conductors or structural members.
  5. Design so that removing a device does not interrupt the continuity of the equipment-grounding circuit.
  6. Provide an equipment-grounding terminal for each incoming power circuit, near the phase conductor terminal.
  7. Size ground wires in accordance with NEC and UL Standards, unless noted otherwise.
  8. Connect all exposed, noncurrent-carrying conductive parts, devices, and equipment to the equipment-grounding circuit.
  9. Connect the door stud on the enclosures to an equipment-grounding terminal within the enclosure using an equipment-bonding jumper.
  10. Bond together all remote and local control panels, processor racks, and conductive enclosures of power supplies and connect to the equipment-grounding circuit to provide a common ground reference.
- J. Provide sunshades and insulation for all outdoor installations.

## 2.07 FINISHES

- A. Finishes:
1. Metallic (non-stainless):
    - a. Metal surfaces of panels shall be prepared by chemical cleaning and mechanical abrasion in accordance with the finish manufacturer's recommendations to achieve a smooth, well-finished surface.
    - b. Scratches or blemishes shall be filled before finishing. One coat of zinc phosphate shall be applied per the manufacturer's recommended dry-film thickness and allowed to dry before applying the finish coat.
    - c. Finish coat shall be a baked polyester-urethane powder, aliphatic air-dry polyurethane, or epoxy enamel to meet NEMA rating specified application.

- d. Exterior of enclosures located outdoors shall be UV-resistant polyester powder coating. Total dry film thickness shall be 3 mils, minimum.
2. Stainless steel:
  - a. Stainless enclosures shall be provided with a Number 4 brushed finish - not painted.
- B. Colors:
  1. Exterior color of panels mounted indoors shall be manufacturer's standard light gray.
  2. Exterior of panels mounted outdoors shall be manufacturer's standard white.
  3. Panel interiors shall be manufacturer's standard white.

## 2.08 SOURCE QUALITY CONTROL

- A. As specified in Section 40\_61\_00.

## PART 3 EXECUTION

### 3.01 EXAMINATION

- A. Examine the installation location for the instrument and verify that the instrument will work properly when installed.
  1. Notify the Engineer promptly if any installation condition does not meet the instrument manufacturer's recommendations or specifications.

### 3.02 INSTALLATION

- A. Install enclosures so that their surfaces are plumb and level within 1/8 inch over the entire surface of the panel; anchor securely to wall and structural supports at each corner, minimum. Direct attachment to drywall is not permitted.
- B. Install the enclosure per guidelines and submitted installation instructions to meet the seismic requirements at the project site.
- C. Provide floor stand kits for wall-mounted enclosures larger than 48 inches high.
- D. Provide 3-1/2-inch high concrete housekeeping pads for freestanding enclosures.
- E. Install gasket and sealing material under panels with floor slab cutouts for conduit:
  1. Undercoat floor-mounted panels.
- F. Provide a full-size equipment-grounding conductor in accordance with NEC included with the power feeder. Terminate to the incoming power circuit-grounding terminal.



- G. All holes for field conduits, etc. shall be cut in the field. There shall be no additional holes, factory cut holes, or hole closers allowed. Incorrect holes, additional holes, or mis-cut holes shall require that the entire enclosure be replaced.
- H. Control panels that are adjacent to motor control centers shall be fully wired to the motor control centers using wireways integral to the motor control center or additional conduits as needed. These interconnections are not shown or reflected on the Conduit Schedule, but shall be shown on the Loop Drawings prepared by the Contractor.
- I. Provide individually fused analog input module points with blown-fuse indicator lights, mounted external of the module on the output terminal strip.
- J. Side Panels:
  - 1. Side panels shall be kept free off all control equipment and devices. Any deviation must be sent to the engineer in writing asking for a deviation.

### **3.03 FIELD QUALITY CONTROL**

- A. As specified in Section 40\_61\_00.

### **3.04 CLEANING**

- A. As specified in Section 40\_61\_00.

### **3.05 PROTECTION**

- A. As specified in Section 40\_61\_00.

## **PART 4 MEASUREMENT**

### **4.01 METHOD OF MEASUREMENT**

- A. No separate measurement shall be made for work under this Section.

## **PART 5 PAYMENT**

### **5.01 METHOD OF PAYMENT**

- A. No separate payment will be made for work under this Section. The cost of the work described in this Section shall be included in the applicable lump sum bid item.

END OF SECTION

## SECTION 40\_80\_01

### TESTING, CALIBRATION, AND COMMISSIONING

#### PART 1 GENERAL

##### 1.01 SUMMARY

- A. Section includes:
  - 1. Testing requirements that apply to process control and instrumentation systems for the entire Project.
- B. Related sections:
  - 1. Section 40\_61\_00 - Common Work Results for Process Control and Instrumentation Systems.
  - 2. Section 40\_61\_05 - Packaged Control System.
  - 3. Section 40\_61\_15 - Control Strategies.
  - 4. Section 40\_61\_16 - Specific Control Strategies.
  - 5. Section 40\_67\_01 - Control Systems - Panels, Enclosures, and Panel Components.

##### 1.02 REFERENCES

- A. As specified in Section 40\_61\_00.
- B. Electronics Industries Alliance (EIA).
- C. Telecommunications Industry Association (TIA).

##### 1.03 DEFINITIONS

- A. As specified in Section 40\_61\_00.
- B. Specific definitions:
  - 1. PTO: Profibus Trade Organization.

##### 1.04 SUBMITTALS

- A. General:
  - 1. Reference additional detailed test submittal scheduling and prerequisite requirements as specified in the Sequencing article of Section 40\_61\_00.
- B. Overall test plan:
  - 1. Develop the PCIS system test submittals in consultation and cooperation with all applicable subcontractors.

2. Develop and submit an overall testing plan for the PCIS. The overall test plan to be reviewed and approved by the Engineer before detailed test plans, procedures, and forms will be reviewed.
  3. Describe the test phases as they apply specifically to this Project and each process system.
  4. Provide a preliminary testing schedule to show the sequence of tests and commissioning as they apply to each process system and each PLC.
  5. Provide a description of factory tests. Describe what equipment will be included, what testing equipment will be used, and the simulator that will be used.
  6. Provide examples of proposed forms and checklists.
- C. Test forms:
1. Provide test and calibration forms and checklists for each of the following:
    - a. Calibration.
    - b. Factory acceptance tests (FAT).
    - c. Loop validation tests.
    - d. Installation tests.
    - e. Functional tests.
    - f. Instrumentation Fine-Tuning.
    - g. Communication Testing including all digital bus and all forms of Ethernet.
  2. Test forms shall include the detailed test procedures, or shall include clear references to separate pages containing the complete test procedure applicable to each form. If references to procedures are used, the complete procedure shall be included with each test binder.
  3. Every page of each test form shall include project name, date, time, name of person conducting the test, signature of person conducting the test, and for witnessed tests, place for signature of person (Engineer and Owner) witnessing the test.
  4. Some sample test forms are included at the end of this Section. These test forms show the minimum required test form content. They are not complete, and have not been customized for this Project. The Contractor is to develop and submit test forms customized for the Project and meeting all of the specified test and submittal requirements.
- D. Test reports:
1. At the conclusion of each test, submit a complete test report, including all test results and certifications.
  2. Include all completed test binders, forms, and checklists.
  3. Submission, review, and acceptance of each test report is required before the start of the sub-system.

## 1.05 QUALITY ASSURANCE

- A. Test personnel:
  - 1. Furnish qualified technical personnel to perform all calibration, testing, and verification. The test personnel are required to be familiar with this Project and the equipment, software, and systems before being assigned to the test program.

## 1.06 SCHEDULING

- A. As specified in Section 40\_61\_00.

## PART 2 PRODUCTS

## PART 3 EXECUTION

### 3.01 INSTALLATION

- A. As specified in Section 40\_61\_00.
- B. Installation supervision:
  - 1. Provide as specified in Section 40\_61\_00.

### 3.02 COMMISSIONING

- A. Source Testing:
  - 1. Provide manufacturer services as specified in the table below.

| Section Number | Section Title  | Source Testing (Witnessed or Non-Witnessed) |
|----------------|--|---|
| 40_61_05       | Packaged Control System                                    | Non-Witnessed                               |
| 40_61_15       | Control Strategies   | Non-Witnessed                               |
| 40_61_16       | Specific Control Strategies                                | Non-Witnessed                               |
| 40_67_01       | Control Systems - Panels, Enclosures, and Panel Components | Witnessed                                   |
| 40_80_01       | Testing, Calibration, and Commissioning                    | Witnessed                                   |

- 2. FAT - general:
  - a. Performed during the Commissioning Phase, source testing activity.

- b. Before shipment to the Project Site, the complete PCIS system including all operator stations, servers, network equipment, printers, PCMs, PLCs, RTUs, LCPs, CCS, peripherals, communications equipment, and other SCADA equipment, shall be assembled, connected, and all software loaded for a fully functional FAT of the integrated system.
  - c. Perform tests to show that the integrated system hardware and software is fully operational and in compliance with the requirements specified in the Contract Documents.
  - d. Additional factory tests are specified in other sections of the Instrumentation and Control Specifications.
  - e. The FAT will be witnessed.
  - f. Right of observation: The Owner retains the right to observe all factory test activities including any and all subsystem preparation, pretests, troubleshooting, retests, warm-up, and software modification and/or update.
  - g. The Owner reserves the right to test any specified function, whether or not explicitly stated in the test submittal.
  - h. Correction of deficiencies: Any deficiencies observed during the test shall be corrected and retested before completion of the test.
  - i. Any changes and/or corrections shall be noted on the test forms. Engineer shall witness the revisions and/or corrections prior to leaving the test site.
  - j. If the corrections and/or revisions are too extensive to be made while the Engineer is scheduled to be at the FAT test site, the FAT shall be, at the Engineer's sole discretion, considered failed, and the test shall be restarted at a later date. All costs for the re-test shall be borne by the Contractor.
3. Testing simulation:
    - a. The FAT shall make use of hardware simulators that contain switches, pilot lights, variable analog signal generators, and analog signal level displays, which shall be connected to the I/O points within the SCADA system. All inputs and outputs shall be simulated and proper control and system operation shall be validated.
    - b. The use of jumper wires, terminal block mounted pilot lights, and loose meters to act as or supply the functionality of a simulator shall not be allowed.
    - c. The hardware simulator may consist of a PLC, operating under a SCADA software package, or other approved software that has its I/O points wired to PLC's I/O points. Software operating on a PC may then act as the switches, pilot lights, variable analog signal generators, and analog signal level displays.
  4. Preliminary FAT:
    - a. A complete preliminary FAT (pre-FAT) shall be conducted utilizing test procedures approved by the Engineer. The pre-FAT test procedure shall be a subset of the full FAT.

- b. The purpose of the pre-FAT is to provide assurance to the Engineer that the SCADA system is ready for the full, witnessed FAT, in terms of both stability and functionality. Debugging of software and troubleshooting of hardware shall occur during and before the pre-FAT, not during the FAT. The Contractor shall fully test the SCADA system and fix all deficiencies found before the full FAT.
  - c. The Owner shall have the right to witness any or all of the pre-FAT testing and shall be notified in writing 20 days before the start of the pre-FAT.
  - d. The pre-FAT test results submittal shall include a letter, signed by the Contractor's project manager or company officer, certifying that the system is complete, has been tested successfully, and is fully ready for the full, witnessed FAT. The submittal shall include completed pre-FAT test forms, signed by the Contractor's staff, and shall be submitted for review before the start of the FAT.
5. Panel inspections:
- a. The Engineer will inspect each control panel for completeness, workmanship, fit and finish, and compliance with the Contract Documents and the accepted shop drawings.
  - b. Provide panel inspection forms as part of the FAT procedures submittal.
  - c. Inspection to include, as a minimum: Layout, mounting, wire and data cable routing, wire tags, power supply, components and wiring, I/O components layout (including terminals, wiring and relays), device layout on doors and front panels, and proper ventilation operation.
  - d. A sample FAT control panel form has been provided at the end of this Section.
6. I/O test:
- a. Verify that I/O is properly wired to field terminals and is properly mapped into the PLC and the rest of the SCADA system, including all operator interface devices.
  - b. Test methodology:
    - 1) Discrete inputs: Apply appropriate input at panel terminal, observe input card indicator, observe data value at each indicated data address, observe data received on all operator interface displays (SCADA workstations and local operator interface (LOI) displays).
    - 2) Discrete outputs: Issue commands from operator interface screen, verify output card indicator light and measure response at field wiring terminals.
    - 3) Analog inputs: Apply appropriate analog input signal at panel terminals, observe data value at each indicated data address, and observe data properly received at each operator screen. Check each point at 0 percent, 50 percent, and 100 percent of scale.
    - 4) Analog outputs: Enter scaled values in the output buffer file, observe the output data file value, and measure appropriate response at panel wiring terminals.
  - c. Test forms to include, but not be limited to:
    - 1) PLC and panel number.

- 2) I/O type.
  - 3) I/O tag name.
  - 4) Panel terminal block numbers.
  - 5) Rack/slot/number of I/O point.
  - 6) Check-off for correct response for each I/O point.
  - 7) Space for comments.
  - 8) Initials of individual performing test.
  - 9) Date test was performed.
  - 10) Witness' signature lines.
7. System configuration test:
- a. Demonstrate and test the setup and configuration of all operator stations, servers, development stations, and peripherals.
  - b. Demonstrate all utility software and functions, such as virus protection, backup, optical drive burning, network monitoring, etc.
  - c. Demonstrate the proper operation of all peripheral hardware.
  - d. Demonstrate all general SCADA functions.
  - e. Demonstrate proper operation of log-on and other access security functions.
  - f. Demonstrate the proper operation of all historical data storage, trend, display, backup, and report functions.
  - g. Test automatic fail over of redundant equipment.
  - h. Demonstrate the proper operation of the alarm display and acknowledgement functions.
  - i. Test forms:
    - 1) For each test, list the specification page and paragraph of the function demonstrated, and provide a description of the function.
    - 2) List the specific tests and steps to be conducted.
    - 3) For each function, list all of the different sub-functions or ways the function can be used, and provide a test check-off for each:
      - a) Include signature and date lines.
8. Control logic test:
- a. The purpose of this test is to verify that all software functions and logic work as specified, along with any hardwired logic or functions in the tested control panels.
  - b. Testing requirements:
    - 1) Demonstrate each function described in Section 40\_61\_15. Demonstrate in detail how each function operates under a variety of operating scenarios. Test to verify the application of each general control strategy function to each specific control strategy or loop description.
    - 2) Demonstrate the proper operation of the programming and configuration for each control strategy or loop description. Test each strategy or loop description on a sentence by sentence and function by function basis. Loops with similar or identical logic must each be tested individually.

- 3) Demonstrate the proper operation of all digital communication links and networks. Verify each digital communication I/O point.
  - 4) Failure testing: In addition to demonstrating correct operation of all specified features, special effort shall be made to demonstrate how the system responds to and recovers from abnormal conditions including, but not limited to: equipment failure, operator error, communications subsystem error, communications failures, simulated/forced software lockups, power failure (both utility power and power to SCADA hardware), process equipment failure, and high system loading conditions.
- c. Test forms:
- 1) Include the fully revised and approved control strategy for the loop being tested.
  - 2) Identify the cause and effect as each I/O point is toggled through the simulator. Check boxes shall be provided to track proper and/or improper operation of the loop.
  - 3) Any deficiencies or operational changes shall be noted on the forms for correction and documentation:
    - a) Include signature and date lines.
- B. Owner Training:
1. Complete Owner training as specified in Section 40\_61\_00.
- C. Installation Testing:
1. General:
    - a. The Owner reserves the right to test any specified function, whether or not explicitly stated in the test submittals.
    - b. Failure testing:
      - 1) In addition to demonstrating correct operation of all specified features, demonstrate how the system reacts and recovers from abnormal conditions including, but not limited to:
        - a) Equipment failure.
        - b) Operator error.
        - c) Communications sub-system error.
        - d) Power failure.
        - e) Process equipment failure.
        - f) High system loading conditions.
    - c. Conduct testing Monday through Friday during normal working hours for no more than 8 hours per day.
      - 1) Testing at other times requires approval of the Engineer.
  2. Sequencing:
    - a. See additional requirements specified in the Sequencing article of Section 40\_61\_00.



3. Calibration:
  - a. After installation but before starting other tests, calibrate and adjust all instruments, devices, valves, and systems, in conformance with the component manufacturer's instructions and as specified in these Contract Documents.
  - b. Components having adjustable features are to be set carefully for the specific conditions and applications of this installation. Test and verify that components and/or systems are within the specified limits of accuracy.
  - c. Replace either individually or within a system, defective elements that cannot achieve proper calibration or accuracy.
  - d. Calibration points:
    - 1) Calibrate each analog instrument at 0 percent, 25 percent, 50 percent, 75 percent, and 100 percent of span, using test instruments with accuracies traceable to NIST.
  - e. Field verify calibration of instruments that have been factory-calibrated to determine whether any of the calibrations are in need of adjustment.
  - f. Analyzer calibration:
    - 1) Calibrate and test each analyzer system as a workable system after installation. Follow the testing procedures directed by the manufacturers' technical representatives.
  - g. Complete instrument calibration sheets for every field instrument and analyzer.
  - h. Calibration tags:
    - 1) Attach a calibration and testing tag to each instrument, piece of equipment, or system.
    - 2) Sign the tag when calibration is complete.
4. LAN cable post-testing:
  - a. After installing the cable and connectors, test all cables using the LAN certification to confirm the installation meets the requirements of the specification.
  - b. Provide test documentation that includes the cable number, total length of cable, a permanent hard copy, as well as a-USB or CD copy of all traces.
    - 1) After installing connectors:
    - 2) Perform cable end-to-end testing on all installed cables from both ends of the cable. Test shall include cable system performance tests and confirm the absence of wiring errors.
    - 3) Submit a signed test report presenting the results of the cable testing.
    - 4) Repair or replace any portions of the system not meeting ANSI/TIA/EIA standards for a Category 6 installation. Repaired sections shall be retested.
  - c. Submit 3 copies of all final documentation (including traces), using the approved test form, to the Engineer upon successful completion of the testing.
5. Ultrasonic and radar check out:
  - a. Check response under all operating conditions.
  - b. Track all responses through trend charts in the SCADA system.

- c. Provide Echo Transmission and signal quality on all level transmitters including guided and unguided units.
  - 1) Provide printout of the actual transmission and all parameters.
- 6. Loop check/validation:
  - a. Check all control loops under simulated operating conditions by causing a range of input signals at the primary control elements and observing appropriate responses of the respective control and monitoring elements, final control elements, and the graphic displays associated with the SCADA system. Issue commands from the SCADA system and verify proper responses of field devices. Use actual process inputs wherever available.
  - b. Provide “end-to-end” tests:
    - 1) Test SCADA system inputs from field device to SCADA system operator workstations.
    - 2) Test SCADA system outputs from SCADA operator workstations to field devices and equipment.
    - 3) Observe and record responses at all intermediate devices.
    - 4) Test and record operator commands and signal readouts to each operator device where there is more than one operator interface point.
    - 5) For each signal, perform separate tests for SCADA computer screens, local operator interface (LOI) screens, and local control panels.
  - c. Retest any loop following any necessary corrections.
  - d. Apply simulated sensor inputs corresponding to 0 percent, 25 percent, 50 percent, 75 percent, and 100 percent of span for networks that incorporate analog elements, and monitor the resulting outputs to verify compliance to accuracy tolerance requirements.
  - e. Apply continuously variable up and down analog inputs to verify the proper operation and setting of discrete devices (signal trips, etc.).
  - f. Apply provisional settings on controllers and alarm setpoints.
  - g. Record all analog loop test data on test forms.
  - h. Exercise each field device requiring an analog command signal, through the SCADA system. Vary, during the validation process, the output from the PLC SCADA system and measure the end device position, speed, etc. to confirm the proper operation of the device for the supplied analog signal. Manually set the output from the SCADA screen at 0 percent, 25 percent, 50 percent, 75 percent, and 100 percent and measure the response at the final device and at any intermediate devices.
  - i. Exercise each field device providing a discrete input to the SCADA system in the field and observe the proper operation shall be observed at the operator workstation:
    - 1) Test limit switches, set limits mechanically, and observe proper operation at the operator workstation.
    - 2) Exercise starters, relay contacts, switch contacts, and observe proper operation.
    - 3) Calibrate and test instruments supplying discrete inputs, and observe proper operation.

- j. Test each device accepting a discrete output signal from the SCADA. Perform the appropriate operator action at the SCADA operator stations (including LOIs, if present) and confirm the proper operation of the field device:
  - 1) Stroke valves through outputs from the SCADA system, and confirm proper directional operation. Confirm travel limits and any feedback signals to the SCADA system.
  - 2) Exercise motors starters from the SCADA system and verify proper operation through direct field observation.
  - 3) Exercise solenoids and other field devices from the SCADA system and verify proper operation through direct field observation.
- k. Include in the test forms:
  - 1) Analog input devices:
    - a) Calibration range.
    - b) Calibration data: Input, output, and error at each test value.
    - c) Analog input associated PLC register address.
    - d) Value in PLC register at each test point.
    - e) Value displayed at each operator interface station (local operator interface displays and SCADA workstations).
  - 2) Analog output devices:
    - a) Calibration range.
    - b) Test value at each test point.
    - c) Analog output associated PLC register address.
    - d) Control variable value at field device at each test point.
    - e) Physical device response at each test point:
      - (1) Response to be actual valve position, or motor speed, etc.
  - 3) Discrete instrument input devices:
    - a) Switch setting, contact action, and dead band.
    - b) Valve position switches:
      - (1) Response in the PLC as the valve is stroked from the PLC.
      - (2) Field observed actual valve position, and valve indicator position as the valve is stroked from the PLC.
    - c) Operator interface switches (control stations and other pilot devices) and associated response.
    - d) Starter and drive auxiliary device contact response.
    - e) Response of all other discrete inputs to the PLC.
  - 4) Discrete output devices:
    - a) Observed response of field device to the discrete output from the PLC.
    - b) Observe the proper operation of Open, Close, Start, Stop, On, Off, etc.
  - 5) Test equipment used and associated serial numbers.

- D. Functional Testing:
1. General:
    - a. Commence Functional tests after completion of all loop check/validation tests:
      - 1) As specified in Section 40\_61\_00, Sequencing and Scheduling article.
    - b. Functional to demonstrate proper operation of all systems with process equipment operating over full operating ranges under conditions as closely resembling actual operating conditions as possible.
    - c. Additional tests are specified in other Instrumentation and Control Sections.
    - d. Follow approved detailed test procedures and check lists for Functional Test activities.
  2. Control logic operational validation:
    - a. The purpose of control logic validation is to field test the operation of the complete control system, including all parts of the SCADA system, all control panels (including vendor control panels), all control circuits, all control stations, all monitored/controlled equipment, and final control elements.
    - b. Demonstrate all control functionality shown on the P&IDs, control schematics, and other drawings, and specified in the loop descriptions, control strategies, Electrical Specifications, and Mechanical Equipment Specifications.
    - c. Test in detail on a function-by-function and sentence-by-sentence basis.
    - d. Thoroughly test all hardware and software functions:
      - 1) Including all hardwired and software control circuit interlocks and alarms.
    - e. Test final control elements, controlled equipment, control panels, and ancillary equipment under startup, shut down, and steady-state operating conditions to verify all logic and control is achieved.
    - f. Control logic validation tests to include, but not limited to: a repeat of all control logic tests from the FAT, modified and expanded to include all field instruments, control panels, circuits, and equipment.
  3. Loop tuning:
    - a. Optimally tune all electronic control stations and software control logic incorporating proportional, integral, or derivative control. Apply control signal disturbances at various process variable levels and adjusting the gain, reset, or rate settings as required to achieve proper response.
    - b. Verify the transient stability of final control elements operating over the full range of operating conditions, by applying control signal disturbances, monitoring the amplitude and decay rate of control parameter oscillations and making necessary controller adjustments as required to eliminate excessive oscillatory amplitudes and decay rates. As a minimum, achieve 1/4 wave amplitude decay ratio damping (subsidence ratio of 4) under the full range of operating conditions.

- c. If excessive oscillations or system instability occur, as determined by the Engineer, continue tuning and parameter adjustments, or develop and implement any additional control algorithms needed to achieve satisfactory control loop operation.
  4. Functional validation sheets:
    - a. Document each Functional test on an approved test form.
    - b. Document loop tuning with a report for each loop, including two-pen chart recordings showing the responses to step disturbance at a minimum of 3 setpoints or process rates approved by the Engineer. Show tuning parameters on the charts, along with time, date, and sign-off by Contractor and Engineer.
    - c. Include on the form, functions which can be demonstrated on a loop-by-loop basis:
      - 1) Loop number and P&ID number.
      - 2) Control strategy, or reference to specification tested.
      - 3) Test procedures: Where applicable, use the FAT function-by-function, sentence-by-sentence loop test checklist forms modified to meet the requirements of the Functional test. Otherwise, create new forms.
    - d. For functions that cannot be demonstrated on a loop-by-loop basis (such as overall plant power failure), include on the test form a listing of the specific steps and tests to be conducted. Include with each test description the following information:
      - 1) Specification page and paragraph of function demonstrated.
      - 2) Description of function and/or text from specification.
      - 3) Test procedures: use the FAT loop test checklist forms modified to meet the specific testing conditions of the Functional test.
  5. Functional certification:
    - a. Provide Manufacturer's Certificate of Installation and Functionality Compliance.
      - 1) Including all test forms with test data entered, submitted to the Engineer with a clear and unequivocal statement that all Functional test requirements have been satisfied.

### 3.03 SCHEDULES

- A. Example test forms:
  1. Example test forms are attached at the end of this Section. They may be used as a starting point for the development of Project-specific test forms for this Project.
  2. The example test forms are not intended to be complete or comprehensive. Edit and supplement the forms to meet the requirements for testing and test forms specified in this Section and other Contract Documents.

## **PART 4 MEASUREMENT**

### **4.01 METHOD OF MEASUREMENT**

- A. No separate measurement shall be made for work under this Section.

## **PART 5 PAYMENT**

### **5.01 METHOD OF PAYMENT**

- A. No separate payment will be made for work under this Section. The cost of the work described in this Section shall be included in the applicable lump sum bid item.

END OF SECTION



|   |  |  |
|---|--|--|
| <b>INSTALLATION AND CERTIFICATION CHECKLIST<br/>DOCUMENTATION</b> |  |  |
|---|--|--|

INSTRUMENT LOOP NO. \_\_\_\_\_

SERVICE DESCRIPTION \_\_\_\_\_

A COPY OF LATEST ISSUE OF THE FOLLOWING DOCUMENTS ARE INCLUDED IN THIS INSTRUMENT INSTALLATION CERTIFICATION FILE:

- INSTRUMENT SPECIFICATION SHEETS (FOR ALL INSTRUMENTS IN THE LOOP)
- INSTRUMENT INSTALLATION DETAILS (FOR ALL INSTRUMENTS IN THE LOOP)
- INSTRUMENT LOOP WIRING DIAGRAMS
- INSTRUMENT INSTALLATION CERTIFICATION CHECKLIST
- SIZING CALCULATIONS
- INSTRUMENT INSTALLATION SCHEDULE (APPLICABLE PART)
- NAMEPLATE SCHEDULE (APPLICABLE PART)
- VENDOR LITERATURE CALIBRATION INFORMATION

INSTRUMENT LOOP IS PART OF EQUIPMENT START-UP/SHUTDOWN INTERLOCKS?  No  Yes

REMARKS: \_\_\_\_\_  
\_\_\_\_\_  
\_\_\_\_\_  
\_\_\_\_\_  
\_\_\_\_\_  
\_\_\_\_\_  
\_\_\_\_\_  
\_\_\_\_\_  
\_\_\_\_\_

CHECKED BY (COMPANY) \_\_\_\_\_ ACCEPTED BY (COMPANY) \_\_\_\_\_

SIGNATURE \_\_\_\_\_ SIGNATURE \_\_\_\_\_

DATE \_\_\_\_\_ DATE \_\_\_\_\_



|  |  |  |
|--|--|--|
|  | <b>SWITCHES<br/>INSTALLATION AND CALIBRATION CHECKLIST</b> |  |
|--|--|--|

INSTRUMENT LOOP NO. \_\_\_\_\_

SERVICE DESCRIPTION \_\_\_\_\_

CHECK BELOW, WHEN COMPLETED:

- BENCH CALIBRATED PER SPECIFICATION SHEET NO. \_\_\_\_\_
- VERIFIED PER P&ID NO. \_\_\_\_\_
- CORRESPONDS TO SPECIFICATION SHEET NO. \_\_\_\_\_
- WIRING CORRECT PER INSTRUMENT LOOP DRAWING NO. \_\_\_\_\_
- INSTALLATION CORRECT PER DETAIL NO. \_\_\_\_\_
- ACCESSORIES ARE PRESENT AND PROPERLY INSTALLED
- INSTRUMENT IS ACCESSIBLE FOR MAINTENANCE OR REMOVAL
- ENGRAVED LAMINATED NAMEPLATE (NO SPELLING ERRORS) PERMANENTLY INSTALLED

INSTRUMENT LOOP IS PART OF EQUIPMENT START-UP/SHUTDOWN INTERLOCKS? No    Yes

| <u>FIELD CALIBRATION CHECK</u> |                                   |                               |                                |                        |                       |       |
|--------------------------------|-----------------------------------|-------------------------------|--------------------------------|------------------------|-----------------------|-------|
| CONTACT NO.                    | FUNCTION                          | FOR SIGNAL                    | CONTACT IS TO                  | AT SPECIFIED VALUE FOR | ACTUAL TRIP POINT WAS |       |
| 1                              | <input type="checkbox"/> ALARM    | <input type="checkbox"/> INCR | <input type="checkbox"/> OPEN  | SET PT = _____         | SET PT = _____        | _____ |
|                                | <input type="checkbox"/> S/D PERM | <input type="checkbox"/> DECR | <input type="checkbox"/> CLOSE | RESET = _____          | RESET = _____         | _____ |
| 2                              | <input type="checkbox"/> ALARM    | <input type="checkbox"/> INCR | <input type="checkbox"/> OPEN  | SET PT = _____         | SET PT = _____        | _____ |
|                                | <input type="checkbox"/> S/D PERM | <input type="checkbox"/> DECR | <input type="checkbox"/> CLOSE | RESET = _____          | RESET = _____         | _____ |
| 3                              | <input type="checkbox"/> ALARM    | <input type="checkbox"/> INCR | <input type="checkbox"/> OPEN  | SET PT = _____         | SET PT = _____        | _____ |
|                                | <input type="checkbox"/> S/D PERM | <input type="checkbox"/> DECR | <input type="checkbox"/> CLOSE | RESET = _____          | RESET = _____         | _____ |
| 4                              | <input type="checkbox"/> ALARM    | <input type="checkbox"/> INCR | <input type="checkbox"/> OPEN  | SET PT = _____         | SET PT = _____        | _____ |
|                                | <input type="checkbox"/> S/D PERM | <input type="checkbox"/> DECR | <input type="checkbox"/> CLOSE | RESET = _____          | RESET = _____         | _____ |

NOTE: PERM IS ABBREVIATION FOR PERMISSIVE



|  |  |  |
|--|--|--|
|  | <b>TRANSMITTER/CONTROLLER/INDICATOR<br/>INSTALLATION AND CALIBRATION CHECKLIST</b> |  |
|--|--|--|

INSTRUMENT LOOP IS PART OF EQUIPMENT START-UP/SHUTDOWN INTERLOCKS?      No      Yes

INSTRUMENT TYPE       TRANSMITTER       CONTROLLER        
 INDICATOR  
                                   OTHER                      DESCRIPTION \_\_\_\_\_

INSTRUMENT TAG NO. \_\_\_\_\_ SERIAL NO. \_\_\_\_\_

SERVICE DESCRIPTION \_\_\_\_\_

| <b><u>BENCH CALIBRATION CHECK</u></b> |               |   |                |              |
|---------------------------------------|---------------|---|----------------|--------------|
| INPUT RANGE = _____                   |               | OUTPUT RANGE = _____  |                |              |
| HEAD CORRECTION = _____               |               | <input type="checkbox"/> LINEAR<br><input type="checkbox"/> SQUARE ROOT |                |              |
| CALIBRATED SPAN = _____               |               |   |                |              |
| % CALIB SPAN                          | DESIRED VALUE | ACTUAL VALUE  | EXPECTED VALUE | ACTUAL VALUE |
| 0                                     |               |   |                |              |
| 50                                    |               |   |                |              |
| 100                                   |               |   |                |              |

CHECK BELOW, WHEN COMPLETED:

- BENCH CALIBRATED PER SPECIFICATION SHEET NO. \_\_\_\_\_
- VERIFIED PER P&ID NO. \_\_\_\_\_
- CORRESPONDS TO SPECIFICATION SHEET NO. \_\_\_\_\_
- WIRING CORRECT PER INSTRUMENT LOOP DRAWING NO. \_\_\_\_\_
- INSTALLATION CORRECT PER DETAIL NO. \_\_\_\_\_
- ACCESSORIES ARE PRESENT AND PROPERLY INSTALLED
- INSTRUMENT IS ACCESSIBLE FOR MAINTENANCE OR REMOVAL
- ENGRAVED LAMINATED NAMEPLATE (NO SPELLING ERRORS) PERMANENTLY INSTALLED

| <b><u>FIELD CALIBRATION CHECK</u></b> |               |                      |                |              |
|---------------------------------------|---------------|----------------------|----------------|--------------|
| INPUT RANGE = _____                   |               | OUTPUT RANGE = _____ |                |              |
| % CALIB SPAN                          | DESIRED VALUE | ACTUAL VALUE         | EXPECTED VALUE | ACTUAL VALUE |
| 0                                     |               |                      |                |              |
| 50                                    |               |                      |                |              |
| 100                                   |               |                      |                |              |

|  |  |  |
|--|--|--|
|  | <b>TRANSMITTER/CONTROLLER/INDICATOR<br/>INSTALLATION AND CALIBRATION CHECKLIST</b> |  |
|--|--|--|

- DIRECT                       REVERSE  
 ACTION VERIFIED AT 50% SPAN  
 ACTION VERIFIED AT \_\_\_\_\_ SPAN

| CONTROLLER SETTINGS |      |    |                     |                  |               |              |               |              |
|---------------------|------|----|---------------------|------------------|---------------|--------------|---------------|--------------|
| SETTING             | GAIN | PB | RESET<br>(INTEGRAL) | DERIV.<br>(RATE) | HIGH<br>LIMIT | LOW<br>LIMIT | ELEV.<br>ZERO | ZERO<br>SUPP |
| PRE-TUNE            |      |    |                     |                  |               |              |               |              |
| POST-TUNE           |      |    |                     |                  |               |              |               |              |

| PRE-TUNE SETTINGS |      |     |                    |                    |                         |
|-------------------|------|-----|--------------------|--------------------|-------------------------|
|                   | GAIN | PB  | RESET (REPEAT/MIN) | RESET (MIN/REPEAT) | DERIVATION<br>(MINUTES) |
| FLOW              | 1.0  | 100 | 10                 | 0.1                | N/A                     |
| LEVEL             | 1.0  | 100 | MIN.               | MAX.               | N/A                     |
| PRESSURE          | 2.0  | 50  | 2.0                | 0.5                | N/A                     |
| TEMP.             | 4.0  | 25  | 0.1                | 10                 | OFF                     |

REMARKS \_\_\_\_\_

\_\_\_\_\_

\_\_\_\_\_

\_\_\_\_\_

\_\_\_\_\_

\_\_\_\_\_

\_\_\_\_\_

\_\_\_\_\_

CHECKED BY (COMPANY) \_\_\_\_\_ ACCEPTED BY (COMPANY) \_\_\_\_\_

SIGNATURE \_\_\_\_\_ SIGNATURE \_\_\_\_\_

DATE \_\_\_\_\_ DATE \_\_\_\_\_

# POND 001 EXPANSION

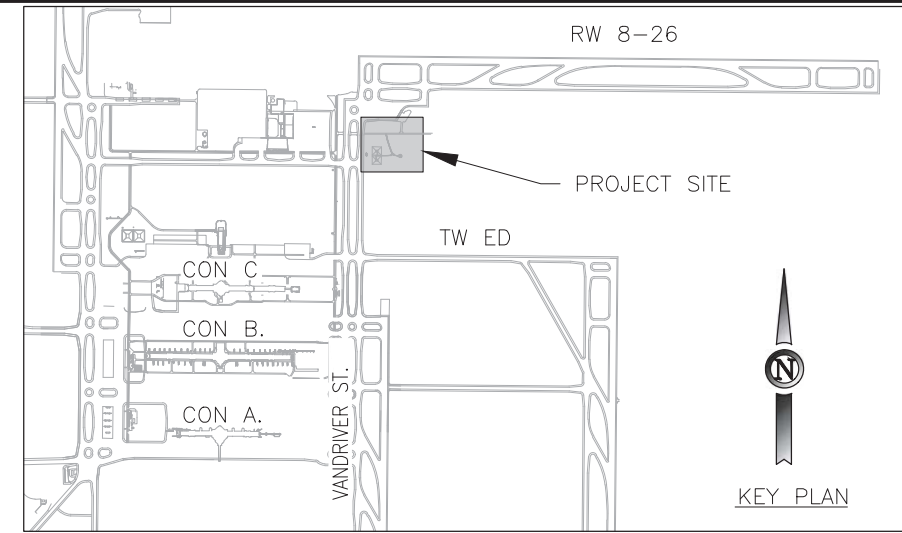

CITY & COUNTY  
of DENVER

DENVER  
INTERNATIONAL  
AIRPORT



**JVIATION**

POND 001 EXPANSION

DEN CONTRACT NO. 201737313

## Issued for Construction

ISSUE DATE NOVEMBER 21, 2017

ISSUE RECORD

| NO. | BY  | PURPOSE | DATE   | CKD |
|-----|-----|---------|--------|-----|
| 1   | JBW | IFC     | 21NO17 |     |
|     |     |         |        |     |
|     |     |         |        |     |
|     |     |         |        |     |
|     |     |         |        |     |
|     |     |         |        |     |
|     |     |         |        |     |
|     |     |         |        |     |
|     |     |         |        |     |

SCALE

DATE APRIL 3, 2017

DRAWN BY: APA

CHECKED BY: JBW

FAA AIP NO. \_\_\_\_\_

WORK BREAKDOWN NO. \_\_\_\_\_

DESIGN CONTRACT NO. 201418360

CONST. CONTRACT NO. 201418360 TASK 5

VOLUME NO. 1

SHEET TITLE

**COVER**

**SHEET**

SHEET NO. C0001

1 OF 61

CADD FILE NO. \_201418360-T5-E1GCOV-POND-001

L:\\_01A\201418360 DWG Pond 001 Expansion Design\CAD\PLANS\201418360-T5-E1GCOV-POND-001.dwg Nov 21, 2017 - 12:12pm james.morehead



**105WEST**  
INCORPORATED  
Jesse Klabunde, PLS  
4201 E. Yale Ave., STE 230  
Denver, CO 80222  
tel: 720.626.3779



**KDG Engineering LLC**  
3500 S. Wadsworth  
Lakewood, Co. 80235  
O: (720) 420-9069  
C: (303) 720-9178  
F: (303) 957-5477



900 S. BROADWAY  
SUITE 350  
DENVER, COLORADO 80209  
PHONE: 303.524.3030  
FAX: 303.524.3031

L:\014\201418360 DIW Pond 001 Expansion Design\CAD\PLANS\201418360-T5-E1GIND-002-POND.dwg Nov 21, 2017 - 12:12pm james.morehead

| INDEX TO DRAWINGS |            |  |      |      |
|-------------------|------------|--|------|------|
| SHEET NO.         | SHEET I.D. | SHEET TITLE                                    | REV. | DATE |
| 1                 | C0001      | COVER SHEET                                    | ---  | ---  |
| 2                 | C0002      | INDEX OF DRAWINGS AND MASTER LEGEND            | ---  | ---  |
| 3                 | C0003      | GENERAL NOTES AND ABBREVIATIONS                | ---  | ---  |
| 4                 | C0004      | ACCESS ROUTE                                   | ---  | ---  |
| 5                 | C0005      | MILESTONE PLAN                                 | ---  | ---  |
| 6                 | C0006      | BARRICADE DETAILS                              | ---  | ---  |
| 7                 | C0007      | SURVEY CONTROL PLAN                            | ---  | ---  |
| 8                 | C0008      | OVERALL SITE PLAN                              | ---  | ---  |
| 9                 | C0009      | BORING MAP AND BORING LOGS                     | ---  | ---  |
| 10                | C0100      | DEMOLITION PLAN                                | ---  | ---  |
| 11                | C0200      | GRADING PLAN                                   | ---  | ---  |
| 12                | C0300      | JOINT PLAN                                     | ---  | ---  |
| 13                | C0400      | TYPICAL SECTIONS                               | ---  | ---  |
| 14                | C0401      | TYPICAL SECTIONS                               | ---  | ---  |
| 15                | C0500      | UTILITY PLAN                                   | ---  | ---  |
| 16                | C0550      | CIVIL DETAILS                                  | ---  | ---  |
| 17                | C0551      | CIVIL DETAILS                                  | ---  | ---  |
| 18                | C0552      | CIVIL DETAILS                                  | ---  | ---  |
| 19                | C0553      | CIVIL DETAILS                                  | ---  | ---  |
| 20                | C0554      | CIVIL DETAILS                                  | ---  | ---  |
| 21                | C0555      | CIVIL DETAILS                                  | ---  | ---  |
| 22                | C0600      | DIW PLAN AND PROFILES                          | ---  | ---  |
| 23                | C0601      | DIW PLAN AND PROFILES                          | ---  | ---  |
| 24                | C0602      | DIW PLAN AND PROFILES                          | ---  | ---  |
| 25                | C0650      | STANDARD MANHOLE DETAILS                       | ---  | ---  |
| 26                | C0651      | STANDARD DETAILS FOR MANHOLES                  | ---  | ---  |
| 27                | C0652      | STANDARD DETAILS FOR MANHOLES                  | ---  | ---  |
| 28                | C0653      | STANDARD DETAILS FOR MANHOLES                  | ---  | ---  |
| 29                | C0656      | STANDARD DETAILS FOR MANHOLES                  | ---  | ---  |
| 30                | C0657      | STANDARD DETAILS FOR MANHOLES                  | ---  | ---  |
| 31                | C0658      | STANDARD DETAILS FOR MANHOLES                  | ---  | ---  |
| 32                | C0700      | INITIAL EROSION CONTROL PLAN                   | ---  | ---  |
| 33                | C0701      | FINAL EROSION CONTROL PLAN                     | ---  | ---  |
| 34                | S1000      | DIVERSION STRUC. MODIFICATION GENERAL NOTES    | ---  | ---  |
| 35                | S1010      | DIVERSION STRUC MODIFICATION-PLAN 1            | ---  | ---  |
| 36                | S1020      | DIVERSION STRUC MODIFICATION-PLAN 2            | ---  | ---  |
| 37                | S1030      | DIVERSION STRUC MODIFICATION-SECTION 1         | ---  | ---  |
| 38                | S1040      | DIVERSION STRUC MODIFICATION-SECTION 2         | ---  | ---  |
| 39                | S1050      | DIVERSION STRUCTURE MODIFICATION-DETAILS       | ---  | ---  |
| 40                | S1060      | MANHOLE BASE DETAIL                            | ---  | ---  |
| 40A               | S1070      | DIW CONC. HEADER & WINGWALL - LAYOUT & DETAILS | ---  | ---  |
| 40B               | S1080      | DIW CONC. HEADER & WINGWALL - DETAILS          | ---  | ---  |
| 41                | M1000      | MECHANICAL LEGEND & ABBREVIATIONS              | ---  | ---  |
| 42                | M1010      | DIVERSION STRUCTURE PLAN                       | ---  | ---  |
| 43                | M1020      | DIVERSION STRUCTURE SECTIONS                   | ---  | ---  |
| 44                | M1030      | MECHANICAL TYPICAL DETAILS                     | ---  | ---  |
| 45                | E1001      | ELECTRICAL LEGEND                              | ---  | ---  |
| 46                | E1010      | ELECTRICAL ABBREVIATIONS                       | ---  | ---  |
| 47                | E1016      | ELECTRICAL TYPICAL DETAILS - I                 | ---  | ---  |
| 48                | E1017      | ELECTRICAL TYPICAL DETAILS - II                | ---  | ---  |
| 49                | E1020      | CONDUIT DEVELOPMENT PLAN                       | ---  | ---  |

| INDEX TO DRAWINGS |            |  |      |      |
|-------------------|------------|--|------|------|
| SHEET NO.         | SHEET I.D. | SHEET TITLE                                | REV. | DATE |
| 50                | E1040      | ELECTRICAL EXISTING FIELD PANEL REFERENCE  | ---  | ---  |
| 51                | E1050      | ELECTRICAL GATE VCP CONTROL DIAGRAM        | ---  | ---  |
| 52                | E1060      | ELECTRICAL MCC ELEVATION                   | ---  | ---  |
| 53                | E2000      | ELECTRICAL SITE PLAN                       | ---  | ---  |
| 54                | E2010      | ELECTRICAL SITE DETAILS                    | ---  | ---  |
| 55                | E3000      | INSTRUMENTATION SYMBOLS & ABBREVIATIONS    | ---  | ---  |
| 56                | E3015      | INSTRUMENTATION TYPICAL DETAILS            | ---  | ---  |
| 57                | E3020      | PROCESS AND INSTRUMENTATION DIAGRAM (P&ID) | ---  | ---  |
| 58                | E3030      | NETWORK BLOCK DIAGRAM                      | ---  | ---  |
| 59                | E3040      | LOOP DIAGRAM STANDARD DETAIL               | ---  | ---  |
| 60                | E3050      | POND 001 PANEL ELEVATION                   | ---  | ---  |
| 61                | E3060      | SCADA SCREENS                              | ---  | ---  |

| SUMMARY OF APPROXIMATE QUANTITIES |   |       |            |          |
|-----------------------------------|---|-------|------------|----------|
| ITEM NO.                          | ITEM DESCRIPTION  | UNITS | SCHEDULE 1 |          |
|                                   |   |       | ESTIMATE   | AS-BUILT |
| 013223a                           | SURVEY  | LS    | 1          |          |
| 015050a                           | MOBILIZATION  | LS    | 1          |          |
| 015525a                           | TRAFFIC CONTROL   | LS    | 1          |          |
| 015525b                           | FLAGGER   | HR    | 2,000      |          |
| 015525c                           | GATE GAURD  | HR    | 2,000      |          |
| 015525d                           | GATE GAURD SHACK  | LS    | 1          |          |
| 015719a                           | SEDIMENT CONTROL LOGS                                   | LF    | 3,270      |          |
| 015719b                           | CULVERT PROTECTION                                      | EA    | 3          |          |
| 015719c                           | VEHICLE TRACKING CONTROL                                | EA    | 1          |          |
| 015719d                           | CONCRETE WASHOUT  | EA    | 1          |          |
| 260500a                           | ELECTRICAL, INSTRUMENTATION, AND CONTROLS               | LS    | 1          |          |
| 310519.14a                        | NONWOVEN GEOTEXTILE FABRIC                              | SY    | 4,365      |          |
| 310519.15a                        | GEOCOMPOSITE DRAINAGE NET WITH 10 OZ FABRIC             | SY    | 14,740     |          |
| 310519.17a                        | 60 MIL RPP GEOMEMBRANE LINER                            | SY    | 14,740     |          |
| 352016.02a                        | 8' X 8' SLIDE GATE WITH HYDRAULIC OPERATOR              | LS    | 1          |          |
| P-150a                            | REMOVE RIPRAP   | SY    | 106        |          |
| P-150b                            | REMOVE 12" DIW (PVC)                                    | LF    | 371        |          |
| P-150c                            | REMOVE 12" SDG (RCP)                                    | LF    | 44         |          |
| P-150d                            | REMOVE DIW MANHOLE                                      | EA    | 2          |          |
| P-150e                            | PLACE 6" RECYCLED CRUSHED CONCRETE                      | SY    | 1,100      |          |
| P-152a                            | UNCLASSIFIED EXCAVATION                                 | CY    | 64,611     |          |
| P-610a                            | CONCRETE PAVEMENT (6" FIBER-REINFORCED)                 | SY    | 4,365      |          |
| D-701a                            | INSTALL 8" DIWF (C900 PVC)                              | LF    | 148        |          |
| D-701b                            | INSTALL 12" DIW (C900 PVC)                              | LF    | 528        |          |
| D-701c                            | INSTALL 12" SDG (CLASS III RCP)                         | LF    | 44         |          |
| D-701d                            | INSTALL 12" FES (RCP)                                   | EA    | 2          |          |
| D-701e                            | INSTALL 16" DIW (C905 PVC)                              | LF    | 165        |          |
| D-701f                            | INSTALL 16" INTAKE PIPE & SCREEN (STAINLESS STEEL)      | LS    | 1          |          |
| D-701g                            | INSTALL 108" DIW (CLASS III RCP)                        | LF    | 590        |          |
| D-701h                            | INSTALL 108" DIW 45' BEND                               | EA    | 2          |          |
| D-705a                            | INSTALL 6" UNDERDRAIN (PERFORATED PVC)                  | LF    | 173        |          |
| D-705b                            | INSTALL 12" UNDERDRAIN (NON-PERFORATED PVC)             | LF    | 132        |          |
| D-710a                            | GROUTED TYPE M RIPRAP                                   | SY    | 110        |          |
| D-751a                            | MODIFY EXISTING DIVERSION STRUCTURE                     | LS    | 1          |          |
| D-751b                            | INSTALL DIW MANHOLE 6' DIAMETER WITH 16" PLUG VALVE     | EA    | 2          |          |
| D-751c                            | INSTALL DIW MANHOLE 6' DIAMETER WITH 2 - 8" PLUG VALVES | EA    | 2          |          |
| D-751d                            | INSTALL DIW MANHOLE 5' DIAMETER                         | EA    | 3          |          |
| D-751e                            | INSTALL HEAD WALL & WINGWALLS (108" OUTFALL)            | LS    | 1          |          |
| T-901a                            | SEEDING (SEED MIX DESIGN 2)                             | AC    | 7          |          |
| T-908a                            | HYDRAULIC MULCHING                                      | AC    | 7          |          |

**NOTES:**  
 1. THE CONTRACTOR IS RESPONSIBLE FOR IDENTIFICATION AND PROCUREMENT OF ALL LONG LEAD ITEMS NECESSARY TO COMPLETE THE PROJECT IN THE ALLOTTED SCHEDULE.

**LEGEND**

|  |   |  |                                      |  |  |
|--|---|--|--------------------------------------|--|--|
|  | PROJECT LIMIT                                   |  | EXISTING (DIW) MANHOLE               |  | SURVEY BENCHMARK   |
|  | EDGE OF PAVEMENT                                |  | PROPOSED (DIW) MANHOLE               |  | CURVE IDENTIFIER   |
|  | EDGE OF SHOULDER                                |  | EXISTING (DIW) MANHOLE TO BE REMOVED |  | COORDINATE DATA IDENTIFIER   |
|  | CENTER LINE WITH STATIONING                     |  | EXISTING STORM UNDERDRAIN CLEANOUT   |  | BORE HOLE  |
|  | PROPOSED VEHICLE SERVICE ROAD                   |  | EXISTING FLARED END SECTION (F.E.S.) |  | UTILITY STRUCTURE AND IDENTIFIERS                                  |
|  | PROPOSED MAJOR CONTOUR                          |  | EXISTING VALVE (DIW)                 |  | PAVEMENT ELEVATIONS AT JOINT INTERSECTIONS AND AT EDGE OF PAVEMENT |
|  | PROPOSED MINOR CONTOUR                          |  | EXISTING HEADWALL                    |  | COORDINATES  |
|  | EXISTING MAJOR CONTOUR                          |  | EXISTING ELECTRICAL MANHOLE          |  |  |
|  | EXISTING MINOR CONTOUR                          |  | EXISTING ELECTRICAL TRANSFORMER      |  |  |
|  | EXISTING DE-ICING WASTE PIPE (DIW)              |  | EXISTING ELECTRICAL SWITCH           |  |  |
|  | PROPOSED DE-ICING WASTE PIPE (DIW)              |  | EXISTING ELECTRICAL JUNCTION BOX     |  |  |
|  | EXISTING DE-ICING WASTE WATER FORCE MAIN (DIWF) |  | EXISTING TAXIWAY AIRFIELD SIGN       |  |  |
|  | EXISTING DIW PIPE TO BE REMOVED                 |  | PROPOSED ELECTRICAL POWER FRAME      |  |  |
|  | EXISTING CULVERT TO BE REMOVED                  |  |                                      |  |  |
|  | EXISTING ELECTRICAL LINE                        |  |                                      |  |  |
|  | PROPOSED ELECTRICAL LINE                        |  |                                      |  |  |



**POND 001 EXPANSION**

| ISSUE RECORD |     |         |          |
|--------------|-----|---------|----------|
| NO.          | BY  | PURPOSE | DATE CKD |
| 1            | JBW | IFC     | 21NO17   |

|  |  |
|--|--|
| SCALE  |  |
| DATE   |  |
| DRAWN BY: <u>APA</u>                               |  |
| CHECKED BY: <u>JBW</u>                             |  |
| FAA AIP NO.  |  |
| WORK BREAKDOWN NO.                                 |  |
| DESIGN CONTRACT NO. <u>201418360</u>               |  |
| CONST. CONTRACT NO. <u>201418360 TASK 5</u>        |  |
| VOLUME NO. <u>1</u>                                |  |
| SHEET TITLE  |  |
| <b>INDEX OF DRAWINGS AND MASTER LEGEND</b>         |  |
| SHEET NO. <u>C0002</u>                             |  |
| 2 OF 61  |  |
| CADD FILE NO. <u>_201418360-T5-E1GIND-002-POND</u> |  |

GENERAL NOTES

- 1. COORDINATES ARE BASED ON THE DIA LDP COORDINATE SYSTEM UNLESS OTHERWISE NOTED.
2. THE USE OF CONTROL MONUMENTS FOR DESIGN OR CONSTRUCTION SURVEYING, OTHER THAN THOSE SHOWN ON THE CONTRACT DRAWINGS IS PROHIBITED. USE OF ANY OTHER MONUMENT IS AT THE CONTRACTOR'S SOLE RISK.
3. ELEVATIONS ARE BASED ON NAVD 88 DATUM FROM NOAA - NGS BENCHMARK "R392" NAVD88 = 5274.65 FEET.
4. THE INFORMATION SHOWN ON THESE DRAWINGS CONCERNING TYPE AND LOCATION OF EXISTING UTILITIES (UNDER AND ABOVE GROUND) IS NOT GUARANTEED TO BE ACCURATE OR ALL INCLUSIVE. THE CONTRACTOR IS RESPONSIBLE FOR MAKING HIS OWN DETERMINATION AS TO TYPE AND LOCATION OF UTILITIES AS MAY BE NECESSARY TO AVOID DAMAGE THERETO. THE CONTRACTOR SHALL VERIFY LOCATIONS OF ALL UTILITIES BY CONTACTING OWNER OF UTILITIES. CONTRACTOR TO CONTACT UTILITY NOTIFICATION CENTER OF COLORADO AT 1-800-922-1987 A MINIMUM OF 48 HOURS PRIOR TO ANY EXCAVATION, IN ACCORDANCE WITH STATE REGULATIONS. THE CONTRACTOR SHALL POPTHOLE ALL EXISTING UTILITIES USING HIGH PRESSURE WATER AT 100' INTERVALS WITHIN 30 DAYS OF NTP TO DETERMINE DEPTHS OF EXISTING UTILITIES AND TO PROVIDE ADEQUATE PROTECTION OF THE UTILITIES DURING CONSTRUCTION. THE CONTRACTOR SHALL RECORD THE EXISTING UTILITY INFORMATION ON THE AS-BUILT DRAWINGS WHICH ARE PROVIDED TO DEN PROJECT MANAGER. ADDITIONAL NONDESTRUCTIVE POT HOLING DURING THE PROJECT, IF NECESSARY, IS THE RESPONSIBILITY OF THE CONTRACTOR.
5. THE CONTRACTOR SHALL NOT AT ANYTIME BE WITHIN A DISTANCE FROM THE CENTERLINE OF AN ACTIVE TAXIWAY TO THE EDGE OF THE OBJECT FREE AREA (OFA) PER THE TABLE BELOW, UNLESS APPROVED BY DEN AIRPORT OPERATIONS.

Table with 4 columns: AIRPORT DESIGN GROUP, DISTANCE FROM CENTERLINE TO OFA, DISTANCE FROM CENTERLINE TO SAFETY AREA. Rows for TW L, TW M.

- 6. THE CONTRACTOR SHALL NOT AT ANYTIME BE WITHIN A DISTANCE FROM CENTERLINE OF ANY ACTIVE RUNWAY TO THE EDGE OF THE OBJECT FREE AREA (OFA) PER THE TABLE BELOW, UNLESS APPROVED BY DEN OPERATIONS.

Table with 4 columns: AIRPORT DESIGN GROUP, DISTANCE FROM CENTERLINE TO OFA, DISTANCE FROM CENTERLINE TO SAFETY AREA. Row for RW 8/26.

- 7. THE CONTRACTOR SHALL PROVIDE A MINIMUM OF ONE VACUUM TRUCK OR ANY OTHER EQUIPMENT NECESSARY TO CONTINUOUSLY CLEAN THE SURFACE OF TAXIWAYS, PAVED VSR'S, AND ANY OTHER PAVED SURFACE OF ANY FOREIGN OBJECT DEBRIS (FOD) THAT MAY RESULT FROM HAULING ACTIVITIES OR ANY OTHER CONSTRUCTION ACTIVITIES. THE CONTRACTOR MUST USE A VACUUM TRUCK THAT DOES NOT CREATE AIRBORNE DUST. ADDITIONAL VACUUM TRUCKS MAY BE REQUIRED TO EXPEDITE THE CLEANING PROCESS. OPENING THE TAXIWAYS OR RUNWAY TO AIRCRAFT OPERATIONS SHALL ONLY BE PROVIDED AFTER A VISUAL INSPECTION OF THE TAXIWAY BY THE ON-DUTY DEN AIRPORT OPERATION MANAGER. NO FOD WILL BE ALLOWED ON THE ACTIVE APRON OR TAXIWAYS.

- 8. THE CONTRACTOR SHALL PROVIDE A MINIMUM OF ONE 4,000 GALLON WATER TRUCK ON-SITE TO CONTROL DUST FROM CONSTRUCTION ACTIVITIES FROM IMPACTING ADJACENT AIRFIELD OPERATIONS.

- 9. ALL CONSTRUCTION EQUIPMENT AND VEHICLES SHALL BE FLAGGED FOR DAYTIME VISIBILITY AND IF APPROPRIATE, LIGHTED FOR NIGHTIME OPERATIONS. VEHICLES WHICH ARE NOT MARKED AND LIGHTED SHALL BE ESCORTED BY A VEHICLE THAT IS EQUIPPED WITH APPROPRIATE MARKING AND LIGHTING DEVICES. MARKING AND LIGHTING SHALL BE IN CONFORMANCE WITH FAA ADVISORY CIRCULAR 150/5210-5, CURRENT EDITION.

- 10. ALL CONTRACTORS AND SUBCONTRACTORS MUST BE MADE AWARE OF ALL SAFETY REQUIREMENTS AND HAZARDS ASSOCIATED WITH AIRCRAFT OPERATIONS AND CONSTRUCTION ACTIVITIES. REFER TO SECTION 013520 - CONSTRUCTION SAFETY - AIRSIDE IN THE GENERAL PROVISIONS PORTION OF THE CONTRACT DOCUMENTS.

- 11. ALL CONSTRUCTION TRAFFIC SHALL BE RESTRICTED TO THE ACCESS AND HAUL ROUTES WITHIN THE AIRPORT OPERATIONS AREA (AOA) EXCEPT WHEN WITHIN THE DESIGNATED CONSTRUCTION AREA. HAUL TRUCKS MUST BE COVERED AT ALL TIMES. END DUMP TRUCKS SHALL BE EQUIPPED WITH TAIL GATES. DEN AIRFIELD OPERATIONS MUST APPROVE THE USE OF THE HAUL ROUTE DAILY THROUGH THE DEN PM OR INSPECTOR ON THE DAILY TELECOM AND OPERATIONS 1 RADIO. HAUL ROUTE AND DEN TRAINING PROGRAM FOR THE CONTRACTOR IS TO BE APPROVED BY OPERATIONS PRIOR TO BEGINNING WORK ON THE SITE, INCLUDING SETTING BARRICADES.

- 12. NO WORK SHALL BEGIN UNTIL DEN OPERATIONS PERSONNEL HAVE COORDINATED THE CLOSURE AND THE CONTRACTOR HAS VERIFIED THE AREA IS CLOSED WITH THE DEN INSPECTOR OR PROJECT MANAGER.

- 13. ALL CONSTRUCTION EQUIPMENT, VEHICLES, PERSONNEL, AND MATERIALS MUST BE CLEARED FROM THE RUNWAY OR TAXIWAY SAFETY AREAS IMMEDIATELY WHEN SO DIRECTED BY THE DEN PROJECT MANAGER OR DEN OPERATIONS PERSONNEL AT NO COST TO THE CITY.

- 14. ALL CONSTRUCTION TRAFFIC SHALL BE RESTRICTED TO THE ACCESS AND HAUL ROUTES WITHIN THE AOA EXCEPT WHEN WITHIN THE DESIGNATED CONSTRUCTION AREA. THE HAUL TRUCKS MUST BE COVERED AT ALL TIMES.

- 15. THE CONTRACTOR SHALL BE RESPONSIBLE FOR THE REPAIR OF ANY PAVEMENT, PAVEMENT MARKINGS, LIGHTING, UTILITIES, MANHOLES, SIGNAGE, AND OTHER APPURTENANCES DAMAGED DUE TO CONSTRUCTION ACTIVITIES.

- 16. ONLY RUBBER TIRED VEHICLES SHALL BE PERMITTED ON PAVED SURFACES. CONTRACTOR IS RESPONSIBLE FOR PROTECTING ALL EXISTING PAVED SURFACES. SEE NOTE 15 CONCERNING CONSTRUCTION ACTIVITY DAMAGE.

- 17. CRAWLER TRACKED VEHICLES SHALL NOT BE ALLOWED ON PAVED SURFACES. TRACKED VEHICLES MUST BE MOVED ACROSS PAVED SURFACES ON WHEELED VEHICLES. THE USE OF MATS BETWEEN CRAWLER TRACKS AND PAVEMENT MAY BE USED TO MOVE CRAWLER TRACKED VEHICLES ACROSS PAVEMENT, PROVIDED NO DAMAGE TO PAVEMENT OCCURS.

- 18. THE CONTRACTOR SHALL BE RESPONSIBLE FOR MAINTAINING ALL HAUL ROADS AND ACCESS ROADS. HAUL ROADS CONSTRUCTED BY THE CONTRACTOR SHALL BE REMOVED AND RECLAIMED TO PRE-CONSTRUCTION CONDITIONS AT THE COMPLETION OF THE CONTRACT OR LEFT IN PLACE AT THE DISCRETION OF THE DEN PROJECT MANAGER.

- 19. MINIMUM OF TWO (2) GATE GUARDS WILL BE SUPPLIED BY THE CITY AND PAID FOR BY THE CONTRACTOR WHENEVER THE CONTRACTOR USES THE CONSTRUCTION ACCESS GATE TO THE AOA. THE CONTRACTOR SHALL REQUEST GATE GUARDS FROM HSS A MINIMUM OF FIVE (5) DAYS PRIOR TO REQUIRING GATE GUARDS. CANCELLATION OF GATE GUARDS MUST BE MADE BY THE CONTRACTOR TO HSS THE DATE REQUESTED OR THE CONTRACTOR WILL PAY FOR THE SCHEDULED SHIFT. GATE GUARDS ARE PAID ACCORDING TO THE HSS AND CONTRACTOR SERVICE AGREEMENT/CONTRACT. CONTRACTOR SHALL PROVIDE A 10' X 12' PORTABLE BUILDING AT THE ACCESS GATE FOR GATE GUARDS USE WITH A PORTABLE GENERATOR AND LIGHT PLANT FOR NIGHT USE, AND A POLE MOUNTED CONVEX MIRROR 24" IN DIAMETER FOR VIEWING INTO TRUCK BEDS. A PORTABLE TYPE TOILET FACILITY SHALL BE PROVIDED FOR GATE GUARDS AND MAINTAINED BY THE CONTRACTOR IN ACCORDANCE WITH SECTION 01 52 10 OF THE GENERAL REQUIREMENTS. MULTIPLE ACTIVE PROJECTS MAY UTILIZE THE CONSTRUCTION ACCESS GATE DEPENDING UPON CURRENT LEVEL OF ACTIVITY. CONTRACTOR MUST OBTAIN AIRPORT SECURITY'S APPROVAL AND SHALL COORDINATE THIS ACCESS WITH AIRPORT SECURITY, HSS, DEN PROJECT MANAGER AND OTHER ACTIVE PROJECTS TO STAFF ACCESS.

- 20. ALL CONTRACTOR EMPLOYEES SHALL BE REQUIRED TO PARK IN THE CONTRACTORS DESIGNATED STAGING AREA ONLY AND SHALL BE DRIVEN TO THE PROJECT SITE IN DESIGNATED CONSTRUCTION VEHICLES ONLY.

- 21. ALL WATER REQUIRED BY THE CONTRACTOR THAT IS OBTAINED FROM DEN SOURCE SHALL BE METERED AND PAID FOR BY THE CONTRACTOR.

THE CONTRACTOR WILL BE REQUIRED TO OBTAIN A HYDRANT METER PERMIT FROM DENVER WATER LISTING EACH HYDRANT USED AND A WATER TANK WAGON PERMIT FOR EACH TANK WAGON USED. THE PERMIT(S) SHALL BE IN POSSESSION OF THE CONTRACTOR AT THE HYDRANT DURING THE TIME THE HYDRANT IS BEING USED. HYDRANT METER PERMITS WILL BE VALID FOR A PERIOD OF ONE (1) YEAR FROM THE TIME OF ISSUANCE OR UNTIL CONTRACT COMPLETION, WHICHEVER OCCURS FIRST. ANY DAMAGE DONE TO THE HYDRANT BY THE CONTRACTOR WILL BE REPAIRED BY DENVER WATER, WITH THE ACTUAL COST OF SUCH REPAIRS BILLED TO THE CONTRACTOR.

IN ACCORDANCE WITH DENVER WATER'S ENGINEERING STANDARDS AND OPERATING RULES, CONTRACTOR SHALL PROVIDE AND USE THE REQUIRED, APPROVED AND PROPERLY SUPPORTED FIRE HYDRANT METER, BACKFLOW PREVENTION ASSEMBLY AND GATE VALVE. CONTRACTOR IS SUBJECT TO DENVER WATER'S HYDRANT USE RULES, REGULATIONS AND FINES FOR VIOLATION. THE CONTRACTOR SHALL ARRANGE BILLING FOR WATER USE THROUGH DENVER WATER.

- 22. ALL UNPAVED AREAS OUTSIDE THE CONTRACT WORK LIMITS INCLUDING STAGING AREAS WHICH WERE DISTURBED BY THE CONTRACTOR SHALL BE RESTORED PER SPECIFICATION T-901 SEEDING, AT THE CONTRACTORS EXPENSE.

- 23. ALL DISTURBED AREAS WITHIN THE PROJECT LIMITS INCLUDING BORROW AREAS SHALL BE TOPSOILED, SEEDED AND AMENDED IN ACCORDANCE WITH SPECIFICATIONS T-901 AND T-905.

- 24. DURING THE WINTER SEASON, SNOW REMOVAL WILL OCCUR AS NEEDED FOR AIRPORT OPERATIONS. THESE OPERATIONS WILL NOT BE DELAYED FOR CONSTRUCTION ACTIVITY. THE CITY WILL NOT BE RESPONSIBLE FOR DAMAGE ASSOCIATED WITH SNOW REMOVAL.

- 25. THE CONTRACTOR IS RESPONSIBLE FOR ALL EROSION, STORM WATER, SEDIMENTATION CONTROL, AND ENVIRONMENTAL PROTECTION MEASURES IN ACCORDANCE WITH THE APPROVED CONTRACTOR'S EROSION AND SEDIMENTATION CONTROL PLAN FOR THE PROJECT SITE, STAGING AREAS, STOCKPILE AREAS, WASTE AREAS, AND HAUL ROUTES. THE CONTRACTOR SHALL BE RESPONSIBLE FOR OBTAINING ALL PERMITS, INCLUDING DEWATERING AND STORM WATER MANAGEMENT PLAN (SWMP) AT NO ADDITIONAL COST TO THE CITY. REFER TO DIVISION 1 OF THE SPECIFICATIONS. CONTRACTOR SHALL BE RESPONSIBLE FOR PROVIDING COLORADO PE STAMPED APPLICATION FOR SWMP REQUIRED BY CITY OF DENVER. REFER TO SECTION 01 57 19 TEMPORARY ENVIRONMENTAL CONTROLS IN THE GENERAL PROVISIONS.

- 26. ALL ENVIRONMENTAL PROTECTION MEASURES SHALL BE INSTALLED AND FUNCTIONAL AT THE SITE PRIOR TO PERFORMING ANY WORK, UNLESS OTHERWISE NOTED. THE CONTRACTOR SHALL MAINTAIN ALL ENVIRONMENTAL PROTECTION MEASURES UNTIL FINAL COMPLETION.

- 27. ALL DEMOLITION AND REMOVAL WORK SHALL BE IN ACCORDANCE WITH SPECIFICATIONS. SPECIAL ATTENTION IS DIRECTED TO THE NEED TO COORDINATE WITH EXISTING FACILITIES AND MAINTAIN ACCESS AND FACILITY OPERATIONS.

- 28. ALL AIRSIDE HAUL ROUTE DRIVERS SHALL BE SUBJECT TO THE CRIMINAL HISTORY RECORDS CHECK (CHRC) OF TEN (10) YEARS AND A SECURITY THREAT ASSESSMENT (STA). REFER TO SECTION 01 14 20 - SECURITY REQUIREMENTS AND SENSITIVE SECURITY INFORMATION (SSI) IN THE GENERAL PROVISIONS. ALL EMPLOYEES MUST BE BADGED PER DEN REQUIREMENTS.

- 29. LOCATION OF ALL EXISTING UTILITIES, STRUCTURES, PROPERTY LINES, SUBSURFACE SOIL OR ROCK CONDITIONS ARE BASED ON THE BEST AVAILABLE INFORMATION AND ARE NOT WARRANTED TO BE EXACT, NOR IS IT WARRANTED THAT ALL ARE SHOWN. ITEMS SHOWN IN PROFILE ARE APPROXIMATE ELEVATIONS ONLY. IN PARTICULAR ALL UNDERGROUND GAS LINES, ELECTRICAL AND TELEPHONE CABLES, ARE NOT WARRANTED TO BE SHOWN.

- 30. THE CONTRACTOR IS RESPONSIBLE FOR LOCATING AND PROTECTING ALL EXISTING ITEMS, UTILITIES, OR STRUCTURES. PRIOR TO THE SUBMISSION OF SHOP DRAWINGS THE CONTRACTOR SHALL CONTACT OWNER AND EXCAVATE TEST PITS TO DETERMINE THE EXACT LOCATION, METHOD OF SUPPORTS AND STATUS OF OPERATIONS OF UNDERGROUND UTILITIES AND STRUCTURES.

- 31. CONTRACTOR SHALL MAINTAIN EMERGENCY ACCESS THROUGH PROJECT SITE AT ALL TIMES. ALL ROADWAYS (TEMPORARY OR PERMANENT) SHALL BE MAINTAINED BY CONTRACTOR.

- 32. THE CONTRACTOR SHALL PROVIDE TEMPORARY SHORING OR LAY BACK SIDE SLOPES OF ALL TRENCHES PER OSHA AND DEN REQUIREMENTS. THE CONTRACTOR SHALL PROVIDE AN EXCAVATION PLAN TO THE DEN PROJECT MANAGER WHICH OUTLINES THE LIMITS OF EXCAVATION, MAXIMUM ALLOWABLE SIDE SLOPES OF ALL EXCAVATIONS, AND SHOWING METHODS TO BE USED. THE CONTRACTOR SHALL CONSIDER SOIL TYPES WHEN DETERMINING THE MAXIMUM ALLOWABLE EXCAVATION SLOPE PER OSHA REQUIREMENTS.

- 33. THE CONTRACTOR SHALL TAKE STEPS TO MINIMIZE SURFACE WATER FROM PRECIPITATION EVENTS FROM FLOWING INTO OPEN EXCAVATIONS. THE CONTRACTOR SHALL BE RESPONSIBLE FOR ALL DEWATERING NECESSARY DUE TO SURFACE WATER FLOWING INTO OPEN EXCAVATIONS. NO ADDITIONAL PAYMENT WILL BE MADE FOR DEWATERING.

- 34. THE CONTRACTOR IS REQUIRED BY THE CITY TO ENROLL IN THE ROLLING OWNER CONTROLLED INSURANCE PROGRAM (ROCIPI). THE CONTRACTOR SHALL FOLLOW THE PROCEDURES AND USE THE FORMS PROVIDED IN THE ROCIPI MANUAL TO ENROLL IN THE ROCIPI. WHEN THE CONTRACTOR AND SUBCONTRACTORS ARE PROPERLY ENROLLED IN THE ROCIPI, THE ROCIPI ADMINISTRATOR WILL ISSUE A CERTIFICATE OF INSURANCE EVIDENCING THE COVERAGE ARRANGED BY THE CITY.

- 35. ANY EXCAVATION FOR UTILITIES GREATER THAN 25 FEET WILL REQUIRE AN APPROVED ENGINEER DESIGNED PRIOR TO CONSTRUCTION. IT IS THE CONTRACTORS RESPONSIBILITY TO PROCURE A COLORADO REGISTERED ENGINEER TO COMPLETE THIS DESIGN. THE DESIGN WILL REQUIRE REVIEW AND APPROVAL BY THE CITY AND COUNTY OF DENVER. ALL COSTS ASSOCIATED WITH THIS DESIGN AND REVIEW OF THE DESIGN ARE INCIDENTAL TO OTHER PAY ITEMS.

- 36. ALL EQUIPMENT AND MATERIALS SUPPLIED BY THE CONTRACTOR WHICH WILL BE IN CONTACT WITH CONTAMINATED STORM WATER (DIW) FLUID SHALL BE COMPATIBLE WITH THE CONTAMINATES LISTED BELOW. WHERE REQUESTED, THE CONTRACTOR SHALL PROVIDE WRITTEN CERTIFICATION OF AN ITEM'S CHEMICAL RESISTANCE TO THE LISTED CONTAMINATES.
36.1. PROPYLENE GLYCOL MAXIMUM 50 PERCENT SOLUTION BY WEIGHT
36.2. POTASSIUM ACETATE MAXIMUM 10 PERCENT SOLUTION BY WEIGHT
36.3. SODIUM FORMATE MAXIMUM 10 PERCENT SOLUTION BY WEIGHT
36.4. JET "A" (AVIATION FUEL) MAXIMUM 1 PERCENT SOLUTION BY WEIGHT
36.5. UNLEADED GASOLINE MAXIMUM 1 PERCENT SOLUTION BY WEIGHT
36.6. DIESEL FUEL MAXIMUM 1 PERCENT SOLUTION BY WEIGHT

- 37. CONTRACTOR TO COORDINATE WITH DEN PROJECT MANAGER FOR ALL CONNECTIONS TO EXISTING SYSTEMS. UNDER NO CIRCUMSTANCES WILL THE CONTRACTOR OPERATE ANY VALVES, GATES, PUMPS, OR OTHER SYSTEMS. DEN ENVIRONMENTAL STAFF WILL OPERATE VALVES, GATES, PUMPS, AND OTHER SYSTEMS WHEN NEEDED BY THE CONTRACTOR. THE CONTRACTOR SHALL GIVE A MINIMUM OF 48 HOURS NOTICE TO DEN WHEN THE OPERATION OF THESE ITEMS IS REQUIRED.

ABBREVIATIONS

Table of abbreviations and their meanings, including AC (ASPHALT CONCRETE), MAX (MAXIMUM), PC (PRECISION APPROACH PATH INDICATOR), etc.



POND 001 EXPANSION

ISSUE RECORD

Table with columns: NO., BY, PURPOSE, DATE CKD. Row 1: 1, JBW, IFC, 21NO17

SCALE

DATE: APRIL 3, 2017

DRAWN BY: APA

CHECKED BY: JBW

FAA AIP NO.

WORK BREAKDOWN NO.

DESIGN CONTRACT NO.

201418360

CONST. CONTRACT NO.

201418360 TASK 5

VOLUME NO.

1

SHEET TITLE

GENERAL

NOTES AND

ABBREVIATIONS

SHEET NO.

C0003

3 OF 61

CADD FILE NO.

\_201418360-T5-11GGNN-003-POND-C0003

U:\DIA\201418360 DWM Pond 001 Expansion Design\CAD\PLANS\201418360-TS-110VMS-004-POND-C0004.dwg  
 Nov 21, 2017 12:13pm james.morehead

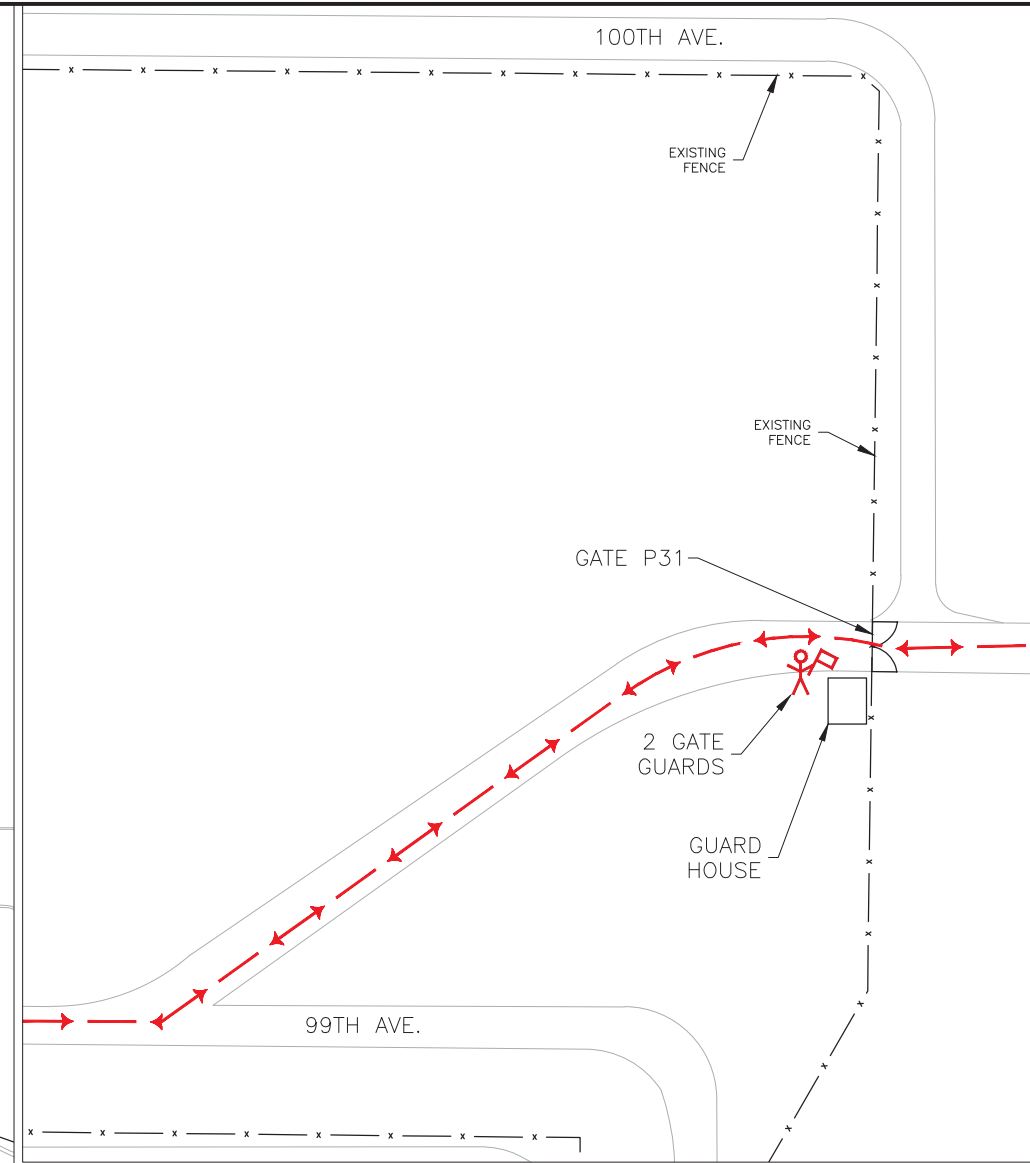
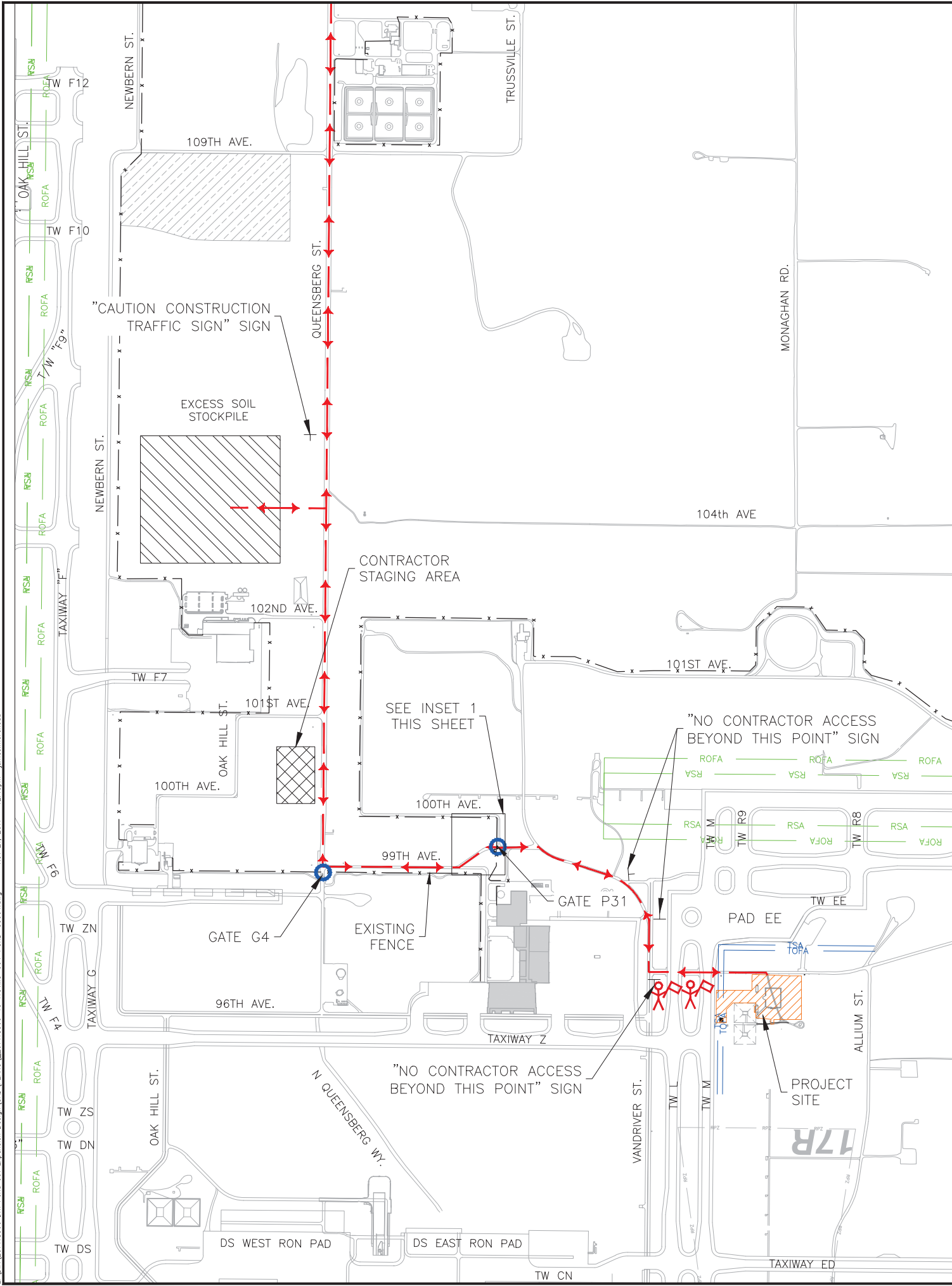

**NOTE:**  
 MINIMUM OF TWO (2) GATE GUARDS WILL BE SUPPLIED BY THE CITY AND PAID FOR BY THE CONTRACTOR WHENEVER THE CONTRACTOR USES THE CONSTRUCTION ACCESS GATE TO THE AOA. THE CONTRACTOR SHALL REQUEST GATE GUARDS FROM HSS A MINIMUM OF FIVE (5) DAYS PRIOR TO REQUIRING GATE GUARDS. CANCELLATION OF GATE GUARDS MUST BE MADE BY THE CONTRACTOR TO HSS THE DATE REQUESTED OR THE CONTRACTOR WILL PAY FOR THE SCHEDULED SHIFT. GATE GUARDS ARE PAID ACCORDING TO THE HSS AND CONTRACTOR SERVICE AGREEMENT/CONTRACT. CONTRACTOR SHALL PROVIDE A 10' X 12' PORTABLE BUILDING AT THE ACCESS GATE FOR GATE GUARDS USE WITH A PORTABLE GENERATOR AND LIGHT PLANT FOR NIGHT USE, AND A POLE MOUNTED CONVEX MIRROR 24" IN DIAMETER FOR VIEWING INTO TRUCK BEDS. A PORTABLE TYPE TOILET FACILITY SHALL BE PROVIDED FOR GATE GUARDS AND MAINTAINED BY THE CONTRACTOR IN ACCORDANCE WITH SECTION 01 52 10 OF THE GENERAL REQUIREMENTS. MULTIPLE ACTIVE PROJECTS MAY UTILIZE THE CONSTRUCTION ACCESS GATE DEPENDING UPON CURRENT LEVEL OF ACTIVITY. CONTRACTOR MUST OBTAIN AIRPORT SECURITY'S APPROVAL AND SHALL COORDINATE THIS ACCESS WITH AIRPORT SECURITY, HSS, DEN PROJECT MANAGER AND OTHER ACTIVE PROJECTS TO STAFF ACCESS.

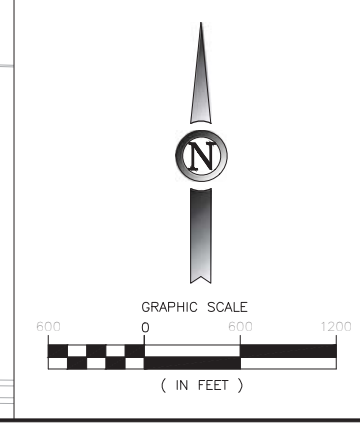

- HAUL ROUTE NOTES**
- ALL CONSTRUCTION ACCESS MUST BE THROUGH GATE P31, UNLESS OTHERWISE APPROVED BY THE DEN PROJECT MANAGER.
  - NO PERSONAL VEHICLES WILL BE ALLOWED ON THE CONSTRUCTION SITE. OFF ROAD VEHICLES ARE NOT ALLOWED IN THE CONSTRUCTION SITE.
  - THE EXACT DIMENSIONS OF THE CONTRACTOR STAGING AREA WILL BE DETERMINED BY THE DEN PROJECT MANAGER AND WILL BE COORDINATED WITH ALL OTHER ACTIVE CONSTRUCTION PROJECTS.
  - ALL AREAS DISTURBED AS A RESULT OF THE CONTRACTOR'S STAGING AND CONSTRUCTION OPERATIONS SHALL BE RESTORED EQUAL TO, OR BETTER THAN, ORIGINAL CONDITION AT THE CONTRACTOR'S SOLE EXPENSE, AND SHALL BE COMPLETED IN A TIMELY MANNER.
  - THE CONTRACTOR IS RESPONSIBLE FOR SECURING THE PROJECT STAGING AREA.
  - ALL AIRSIDE HAUL ROUTE DRIVERS SHALL BE SUBJECT TO A CRIMINAL HISTORY RECORDS CHECK (CHRC) OF TEN (10) YEARS AND A SECURITY THREAT ASSESSMENT (STA). REFER TO SECTION 01 14 20 - SECURITY REQUIREMENTS AND SENSITIVE SECURITY INFORMATION (SSI) IN THE GENERAL PROVISIONS. ALL EMPLOYEES MUST BE BADGED PER DEN REQUIREMENTS.
  - AIRSIDE STAGING AND STOCKPILE AREA SHALL BE APPROVED BY THE DEN PROJECT MANAGER PRIOR TO MOBILIZATION. EQUIPMENT AND STOCKPILES SHALL REMAIN OUTSIDE OF ALL AIRFIELD CRITICAL AREA LIMITS. CONTRACTOR SHALL SUBMIT AN EQUIPMENT PLAN FOR VERIFICATION OF EQUIPMENT HEIGHTS TO THE DEN PROJECT MANAGER. OBSTRUCTION ANALYSIS OF PART 77 AIRFIELD SURFACES SHALL BE COMPLETED AND APPROVED PRIOR TO MOBILIZATION.
  - CONTRACTOR HAUL TRUCKS AND EQUIPMENT SHALL BE LIMITED TO STREET LEGAL VEHICLES (AXLES, LOAD WEIGHT), AS DEFINED BY THE CITY OF DENVER.
  - THE CONTRACTOR SHALL PROVIDE HAUL ROUTE MONITORS AT DESIGNATED LOCATIONS SHOWN ON THIS PLAN TO CONTROL CONTRACTOR VEHICLES FOR THE DURATION OF THIS PROJECT. ALL HAUL ROUTE MONITORS SHALL BE CONSTRUCTION ROUTE TRAINED AND BADGED PER DEN REQUIREMENTS AT THE CONTRACTOR'S EXPENSE.
  - HAUL VEHICLES SHALL NOT BE PERMITTED TO CROSS ANY ACTIVE TAXIWAYS OR OTHER AIRCRAFT PAVEMENT. TAXIWAYS M AND L WILL BE CLOSED NORTH OF TAXIWAY ED FOR THE DURATION OF THE PROJECT.

**LEGEND:**

|  |                                    |
|--|------------------------------------|
|  | PROJECT SITE                       |
|  | CONTRACTOR STAGING AREA            |
|  | EXCESS STOCKPILE AREA              |
|  | HAUL ROUTE/CONTRACTOR ACCESS ROUTE |
|  | RSA RUNWAY SAFETY AREA             |
|  | ROFA RUNWAY OBJECT FREE AREA       |
|  | TSA TAXIWAY SAFETY AREA            |
|  | TOFA TAXIWAY OBJECT FREE AREA      |
|  | AOA FENCE                          |
|  | FLAGMAN / GATE GUARD               |
|  | AOA GATE ACCESS                    |
|  | CONTRACTOR TRAFFIC GUIDANCE SIGN   |

**CITY & COUNTY of DENVER**  
**DENVER INTERNATIONAL AIRPORT**  
  
**AVIATION**  
**POND 001 EXPANSION**

---

**ISSUE RECORD**  
 NO. BY PURPOSE DATE CKD  
 1 JBW IFC 21NO17

---

SCALE \_\_\_\_\_  
 DATE **APRIL 3, 2017**  
 DRAWN BY: **APA**  
 CHECKED BY: **JBW**  
 FAA AIP NO. \_\_\_\_\_  
 WORK BREAKDOWN NO. \_\_\_\_\_  
 DESIGN CONTRACT NO. **201418360**  
 CONST. CONTRACT NO. **201418360 TASK 5**  
 VOLUME NO. **1**

---

SHEET TITLE  
**ACCESS ROUTE**

---

SHEET NO.  
**C0004**  
 4 OF 61  
 CADD FILE NO.  
 \_201418360-TS-110VMS-004-POND-C0004



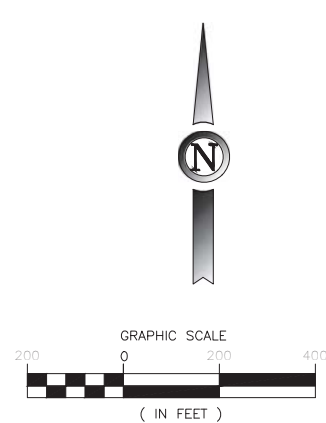
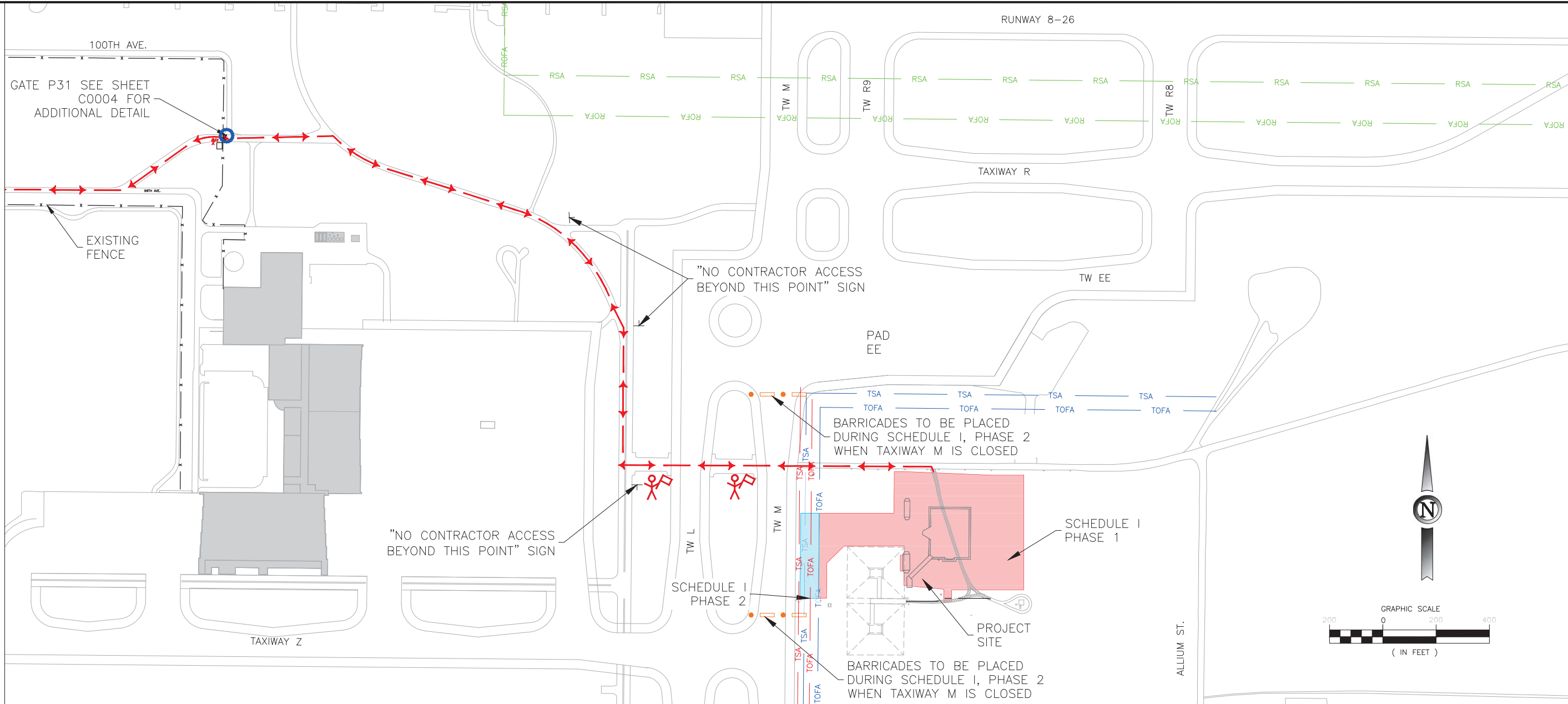

LEGEND:

|  |                                    |  |      |                                   |
|--|------------------------------------|--|------|-----------------------------------|
|  | SCHEDULE 1, PHASE 1                |  | TSA  | TAXIWAY SAFETY AREA (ADG V)       |
|  | SCHEDULE 1, PHASE 2                |  | TOFA | TAXIWAY OBJECT FREE AREA (ADG V)  |
|  | CONTRACTOR STAGING AREA            |  | TSA  | TAXIWAY SAFETY AREA (ADG IV)      |
|  | EXCESS STOCKPILE AREA              |  | TOFA | TAXIWAY OBJECT FREE AREA (ADG IV) |
|  | HAUL ROUTE/CONTRACTOR ACCESS ROUTE |  | x    | AOA FENCE                         |
|  | FLASHER BARRICADES                 |  |      | FLAGMAN / GATE GUARD              |
|  | RSA                                |  |      | AOA GATE ACCESS                   |
|  | ROFA                               |  |      | CONTRACTOR TRAFFIC GUIDANCE SIGN  |

| LEGEND:                         | DURATION                                |
|---------------------------------|---|
| NTP/ADMINISTRATIVE/MOBILIZATION | 30 CALENDAR DAYS                        |
|                                 | SCHEDULE 1 PHASE 1<br>100 CALENDAR DAYS |
|                                 | SCHEDULE 1 PHASE 2<br>40 CALENDAR DAYS  |

- SCHEDULE 1, PHASE 1 AND PHASE 2 CONSTRUCTION NOTES:**
- WORK SHALL BEGIN WHEN ALL SUBMITTALS HAVE BEEN APPROVED AND ALL CONSTRUCTION MATERIALS HAVE BEEN PROCURED THAT ARE RELEVANT TO ALL SCHEDULES. IF ANY WORK IS BEGUN WITHOUT THIS STEP BEING COMPLETED, CONTRACTOR WILL INCUR ALL COST IMPACTS ASSOCIATED WITH ANY RELATED DELAYS.
  - THE CONTRACTOR SHALL PREPARE A DETAILED SAFETY PLAN COMPLIANCE DOCUMENT (SPCD) AS STATED IN THE ADVISORY CIRCULAR 150-5370-2G PRIOR TO CONSTRUCTION. CONTRACTOR TO REFER TO CONSTRUCTION SAFETY AND PHASING PLAN DOCUMENT FOR REQUIREMENTS FOR THE SAFETY PLAN COMPLIANCE DOCUMENTS.
  - CONTRACTOR IS REQUIRED TO SUBMIT A TRAFFIC CONTROL PLAN 10 DAYS PRIOR TO CONSTRUCTION FOR REVIEW AND APPROVAL BY THE DEN PROJECT MANAGER.
  - WORK SHALL BEGIN IMMEDIATELY AFTER ADMINISTRATIVE DURATION IS COMPLETE. ALL SUBMITTALS ARE REQUIRED TO BE APPROVED AND ALL CONSTRUCTION MATERIALS HAVE BEEN PROCURED THAT ARE RELEVANT TO SCHEDULE 1 PHASE 1 AND PHASE 2.

- SCHEDULE 1, PHASE 2 CONSTRUCTION NOTES:**
- DURING SCHEDULE 1, PHASE 2 A NOTAM WILL BE IN PLACE RESTRICTING TAXIWAY M TO AN ADG IV TAXIWAY. WHEN TAXIWAY M IS RESTRICTED TO ADG IV, THE ADG IV TAXIWAY SAFETY AREA IS LOCATED 85.5 FEET FROM TAXIWAY M CENTERLINE, AND THE ADG IV OBJECT FREE AREA IS LOCATED 129.5' FROM TAXIWAY M CENTERLINE.
  - TAXIWAY M IS TO REMAIN OPEN WHEN CONTRACTOR EQUIPMENT AND PERSONNEL ARE NOT SCHEDULED TO BE WITHIN THE ADG IV OBJECT FREE AREA. THE CONTRACTOR WILL BE REQUIRED TO COORDINATE WITH THE DEN PROJECT MANAGER FOR CLOSURE OF TAXIWAY M DURING TIMES WHEN IT IS REQUIRED TO HAVE CONTRACTOR EQUIPMENT AND PERSONNEL WITHIN THE RESTRICTED ADG IV OBJECT FREE AREA.
  - THE CONTRACTOR WILL COORDINATE ANY CLOSURE OF TAXIWAY M WITH THE DEN PROJECT MANAGER. WHEN THE DEN PROJECT MANAGER APPROVES THE CLOSURE OF TAXIWAY M AND THE APPROPRIATE NOTAM IS IN PLACE, THE CONTRACTOR WILL PLACE BARRICADES AS SHOWN ON THIS SHEET.
  - THE CONTRACTOR WILL NOT HAVE ANY PERSONNEL, MATERIALS, OR EQUIPMENT WITHIN THE TAXIWAY OBJECT FREE AREA WHILE TAXIWAY M IS OPEN TO AIRCRAFT TRAFFIC.
  - THE CONTRACTOR WILL NOT STORE MATERIALS OR EQUIPMENT WITHIN THE ADG V TAXIWAY OBJECT FREE AREA AT ANY TIME.

ISSUE RECORD

| NO. | BY  | PURPOSE | DATE   | CKD |
|-----|-----|---------|--------|-----|
| 1   | JBW | IFC     | 21NO17 |     |

SCALE

DATE: APRIL 3, 2017

DRAWN BY: APA

CHECKED BY: JBW

FAA AIP NO:

WORK BREAKDOWN NO.

DESIGN CONTRACT NO. 201418360

CONST. CONTRACT NO. 201418360 TASK 5

VOLUME NO. 1

SHEET TITLE  
**MILESTONE PLAN**

SHEET NO. C0005

5 OF 61

CADD FILE NO. \_201418360-T5-11GVMS-005-POND-C0005

U:\DIA\201418360 DWM Pond 001 Expansion Design\CADD\PLANS\201418360-T5-11GVMS-005-POND-C0005.dwg  
 Nov 21, 2017 12:14pm james.morehead



ISSUE RECORD

| NO. | BY  | PURPOSE | DATE   | CHKD |
|-----|-----|---------|--------|------|
| 1   | JBW | IFC     | 21NO17 |      |

SCALE

DATE APRIL 3, 2017

DRAWN BY: APA

CHECKED BY: JBW

FAA AIP NO. \_\_\_\_\_

WORK BREAKDOWN NO. \_\_\_\_\_

DESIGN CONTRACT NO. 201418360

CONST. CONTRACT NO. 201418360 TASK 5

VOLUME NO. 1

SHEET TITLE

**BARRICADE  
DETAILS**

SHEET NO.

**C0006**

6 OF 61

CADD FILE NO.

201418360-T5-11GVMS-006-POND-C0006

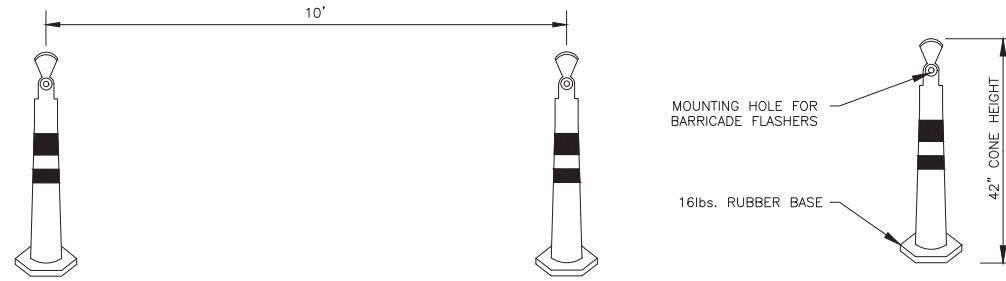

TUBULAR FLASHER  
BARRICADE  
N.T.S.

BARRICADE NOTES:

1. BARRICADES WILL BE PROVIDED BY DEN. THE CONTRACTOR WILL BE RESPONSIBLE FOR THE INSTALLATION AND MAINTENANCE OF ALL BARRICADES.
2. FLASHERS TO BE SOLAR POWERED. LENS TO BE RED AND BE ABLE TO ROTATE 90°.
3. FACING OF LOW-PROFILE FLASHER AND TUBULAR FLASHER BARRICADE(S) TO BE COVERED WITH REFLECTIVE MATERIAL.
4. LOW-PROFILE BARRICADES TO BE INTERLOCKED ALONG OPERATIONAL PAVEMENT, ADJACENT TO CONSTRUCTION, AS DIRECTED BY THE DEN PROJECT MANAGER.
5. TUBULAR FLASHER BARRICADES TO BE PLACED AT CORNERS OF EXCAVATED AREA.
6. FLASHERS SHALL BE SECURED TO THE BARRICADES, AS APPROVED BY AIRPORT OPERATIONS. ALTERNATE FLASHER LENSES SO THAT EVERY OTHER LENS IS ROTATED 90°.
7. LOW-PROFILE BARRICADES SHALL BE OF LOW MASS, EASILY COLLAPSIBLE UPON CONTACT WITH AN AIRCRAFT OR ANY OF ITS COMPONENTS, AND WEIGHTED.
8. TUBULAR FLASHER BARRICADES SHALL BE 42" GRABBER TUBE WITH 16 LB RUBBER BASE, OR APPROVED EQUAL.
9. THE CONTRACTOR SHALL MAINTAIN ALL BARRICADES DURING DAYLIGHT HOURS. CONTRACTORS SHALL ALSO PROVIDE THE AIRPORT SPARE BATTERIES AND LIGHTBULBS (IF NECESSARY) FOR MAINTENANCE DURING NIGHTTIME HOURS.
10. ALL BARRICADES SHALL HAVE FUNCTIONAL FLASHERS AT ALL TIMES DURING CONSTRUCTION.

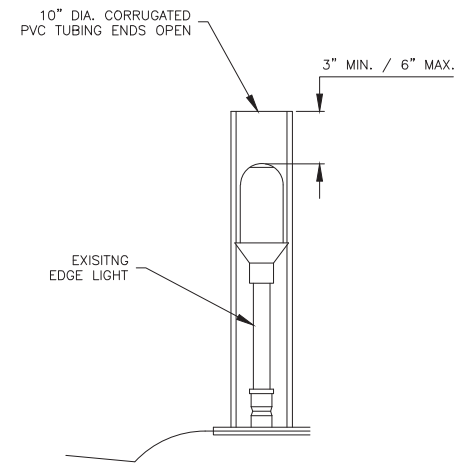

NOTES:

1. CONTRACTOR TO ENSURE NO DAMAGE WHEN PLACING AND REMOVING 10" DIAMETER CORRUGATED PVC TUBING.
2. ANY DAMAGE TO TAXIWAY EDGE LIGHTS WILL REQUIRE REPLACEMENT OF TAXIWAY EDGE LIGHTS AT CONTRACTOR'S EXPENSE.

TEMPORARY COVERED  
TAXIWAY EDGE LIGHT DETAIL

N.T.S.



PLAN

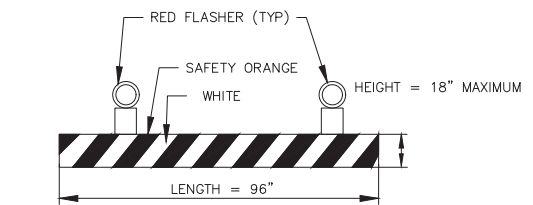

ELEVATION

LOW PROFILE FLASHER BARRICADE DETAIL

NO SCALE



TYPICAL BARRICADE PLACEMENT DETAIL

N.T.S.

NOTE:

1. FLASHER BARRICADES WILL BE REQUIRED ALONG THE EDGE OF ANY VERTICAL DROP OFF GREATER THAN 3". DIA OPERATIONS WILL ISSUE NOTAM TO ADVISE AIRCRAFT OF THIS CONDITION.

**NOTES:**

1. PRIOR TO BEGINNING ANY SURVEY WORK, THE CONTRACTOR AND THEIR SURVEYORS MUST MEET WITH THE DEN SURVEY SECTION TO REVIEW REQUIREMENTS AND TECHNICAL SPECIFICATIONS FOR SURVEYING ON DEN PROPERTY.
2. A MINIMUM OF TWO "DEEP ROD" VERTICAL CONTROL MONUMENTS SHALL BE USED FOR ESTABLISHING A PROJECT VERTICAL DATUM. A "DEEP ROD" MONUMENT SHALL BE DEFINED AS A MONUMENT SET USING NATIONAL GEODETIC SURVEY APPENDIX H - SPECIFICATIONS AND SETTING PROCEDURES FOR THREE-DIMENSIONAL MONUMENTATION, MAY 11, 1988.
3. THE HORIZONTAL COORDINATES SHOWN HEREON ARE BASED ON THE DENVER INTERNATIONAL AIRPORT LOW DISTORTION PROJECTION (LDP) UTILIZING THE FOLLOWING PARAMETERS:  
 GEODETIC DATUM: NAD83 (07)  
 PROJECTION: TRANSVERSE MERCATOR  
 UNITS: US SURVEY FEET  
 LATITUDE: 39°52'30" (N)  
 LONGITUDE: 104°39'45" (W)  
 FALSE NORTHING: 200,000 USFT  
 FALSE EASTING: 600,000 US FT  
 COMBINED SCALE FACTOR: 1.000253 (EXACT)  
 GEOID: GEOID09  
 PROJECT HEIGHT: 5,340 USFT
4. ELEVATIONS SHOWN HEREON ARE BASED ON NGS PACS STATION 788 (DVX P), ELEVATION = 5,403.42' AND NGS VERTICAL CONTROL STATION DR PP, ELEVATION = 5,357.25'. 105 WEST, INC. COMPLETED A CLOSED DIFFERENTIAL LEVEL LOOP THROUGH ALL SET PROJECT CONTROL UTILIZING THE ELEVATION AT DR PP.  
 VERTICAL DATUM: NORTH AMERICAN VERTICAL DATUM OF 1988 (NAVD88)
5. PER THE REQUEST OF THE DEN SURVEY UNIT, ALL CONTROL SHOWN HEREON WAS PERPETUATED FROM ONGOING DEN/105 WEST RUNWAY 8-26 COMPLEX PROJECT.

**LEGEND**

○ XXX = 105 WEST, INC. SET PROJECT CONTROL POINT

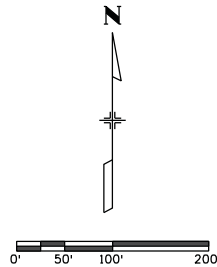

**NOTES CONT.:**

6. SURVEYING ACCURACY AND TOLERANCE: HAVE HORIZONTAL ACCURACY OF AT LEAST 1:40,000; HAVE VERTICAL LOOP CLOSURE OF AT LEAST 0.03 FEET PER MILE; UTILIZE DIGITAL LEVELS; UTILIZE NAVD 88 VERTICAL DATUM; UTILIZE TWO NGS STYLE 3D DEEP ROD MONUMENT WITH KNOWN ELEVATION.
7. REFER TO TECHNICAL SPECIFICATION DIVISION 1: GENERAL REQUIREMENTS, SECTION 1050 PART 3.03 FOR FURTHER INFORMATION ON SURVEYING ACCURACY AND TOLERANCES.
8. DEN LOW DISTORTION PROJECTION (LDP) COORDINATES AND ELEVATIONS OF THE DEEP ROD MONUMENTS WERE PROVIDED BY MR. DENNIS HAMLIN, PLS OF THE DEN AIRPORT INFRASTRUCTURE MANAGEMENT (AIM) DIVISION. MR. HAMLIN CAN BE REACHED AT (303) 342-4428.
9. THE FIELD SURVEY WAS PERFORMED BY 105 WEST, INC. IN ACCORDANCE WITH APPLICABLE STANDARDS OF PRACTICE IN THE STATE OF COLORADO. FURTHERMORE, THE FIELD SURVEY MET OR EXCEEDED SURVEY ACCURACY REQUIREMENTS OF THE DENVER INTERNATIONAL AIRPORT. THE PURPOSE OF THIS SURVEY IS FOR THE PROPOSED POND 001 PROJECT.
10. THIS SURVEY DOES NOT CONSTITUTE A TITLE SEARCH BY 105 WEST, INC., NOR IS IT INTENDED TO BE CONSTRUED AS A BOUNDARY SURVEY.
11. DATE OF FIELD SURVEY: MARCH, 2017.
12. ACCORDING TO COLORADO LAW YOU MUST COMMENCE ANY LEGAL ACTION BASED UPON ANY DEFECT IN THIS SURVEY WITHIN THREE YEARS AFTER YOU FIRST DISCOVER SUCH DEFECT. IN NO EVENT MAY ANY ACTION BASED UPON ANY DEFECT IN THIS SURVEY BE COMMENCED MORE THAN TEN YEARS FROM THE DATE OF CERTIFICATION.
13. ANY PERSON WHO KNOWINGLY REMOVES, ALTERS OR DEFACES ANY PUBLIC LAND SURVEY MONUMENT OR LAND BOUNDARY MONUMENT OR ACCESSORY, COMMITS A CLASS TWO (2) MISDEMEANOR PURSUANT TO C.R.S.

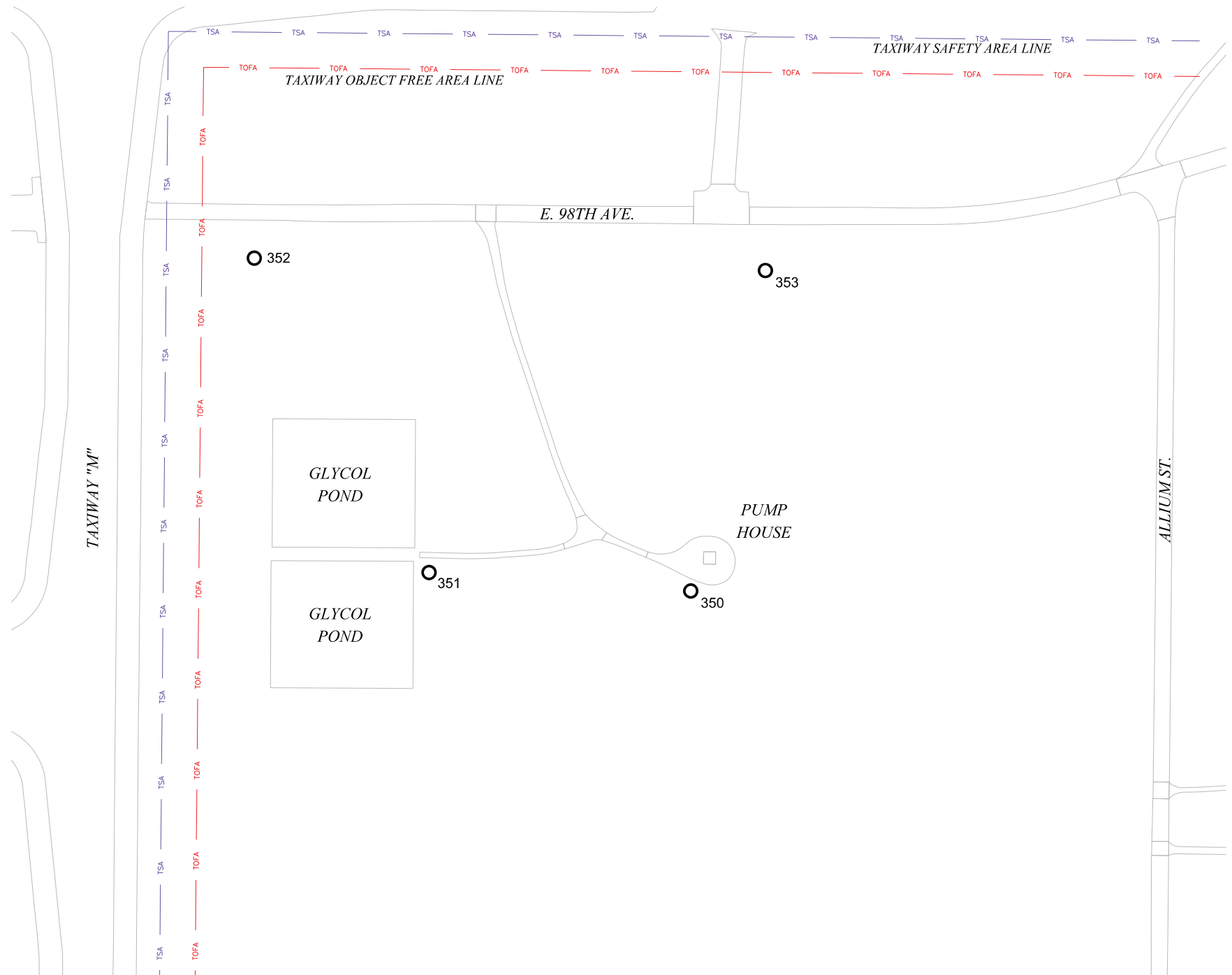

I, RICHARD D. MUNTEAN, A LICENSED PROFESSIONAL SURVEYOR IN THE STATE OF COLORADO, DO HEREBY STATE THAT THE SURVEY CONTROL REPRESENTED BY THIS MAP WAS PERFORMED UNDER MY SUPERVISION, AND THAT THIS MAP AND THE NOTES SHOWN HEREON ACCURATELY REPRESENT SAID SURVEY TO THE BEST OF MY KNOWLEDGE, INFORMATION AND BELIEF.



RICHARD D. MUNTEAN, PLS NO. 38189  
 FOR AND ON BEHALF OF 105 WEST, INC.

| PROJECT CONTROL COORDINATE TABLE |                     |             |                      |  |
|----------------------------------|---------------------|-------------|----------------------|--|
| Point No.                        | Project Coordinates |             | Elev(ft)<br>(NAVD88) | Description  |
|                                  | Northing(ft)        | Easting(ft) |                      |  |
| 350                              | 198,663.271         | 600,986.622 | 5,358.99             | SET 2" ALUM CAP on 36" x 5/8" REBAR "105 WEST INC CONTRÖL POINT" |
| 351                              | 198,690.916         | 600,596.165 | 5,353.12             | SET 2" ALUM CAP on 36" x 5/8" REBAR "105 WEST INC CONTRÖL POINT" |
| 352                              | 199,159.894         | 600,335.420 | 5,345.96             | SET 2" ALUM CAP on 36" x 5/8" REBAR "105 WEST INC CONTRÖL POINT" |
| 353                              | 199,141.393         | 601,097.951 | 5,347.82             | SET 2" ALUM CAP on 36" x 5/8" REBAR "105 WEST INC CONTRÖL POINT" |
| DR PP                            | NA                  | NA          | 5,357.25             | NGS VERTICAL CONTROL STATION "DR PP", NOT SHOWN                  |
| 788                              | 192,823.846         | 601,278.631 | 5,403.42             | NGS PACS STATION "DVX P", NOT SHOWN                              |
| 792                              | 193,097.279         | 584,621.758 | 5,350.37             | NGS SACS STATION "DVX N", NOT SHOWN                              |



POND 001  
 EXPANSION

ISSUE RECORD

| NO. | BY  | PURPOSE | DATE    | CKD |
|-----|-----|---------|---------|-----|
| 1   | JJK | IFC     | 19JUN17 |     |

SCALE AS SHOWN

DATE 5/1/2017

DRAWN BY: JJK

CHECKED BY: RDM

FAA AIP NO:

WORK BREAKDOWN NO.

DESIGN CONTRACT NO.

CONST. CONTRACT NO.

VOLUME NO.

SHEET TITLE

SURVEY  
 CONTROL  
 PLAN

SHEET NO.

C0005

CADD FILE NO.

L:\014\201418360 DIW Pond 001 Expansion Design\CAD\PLANS\201418360-TS-110GSP-008-POND-C0008.dwg Nov. 21, 2017 12:15pm james.morehead

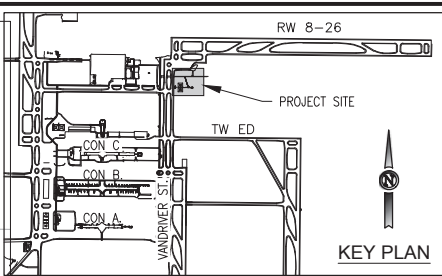
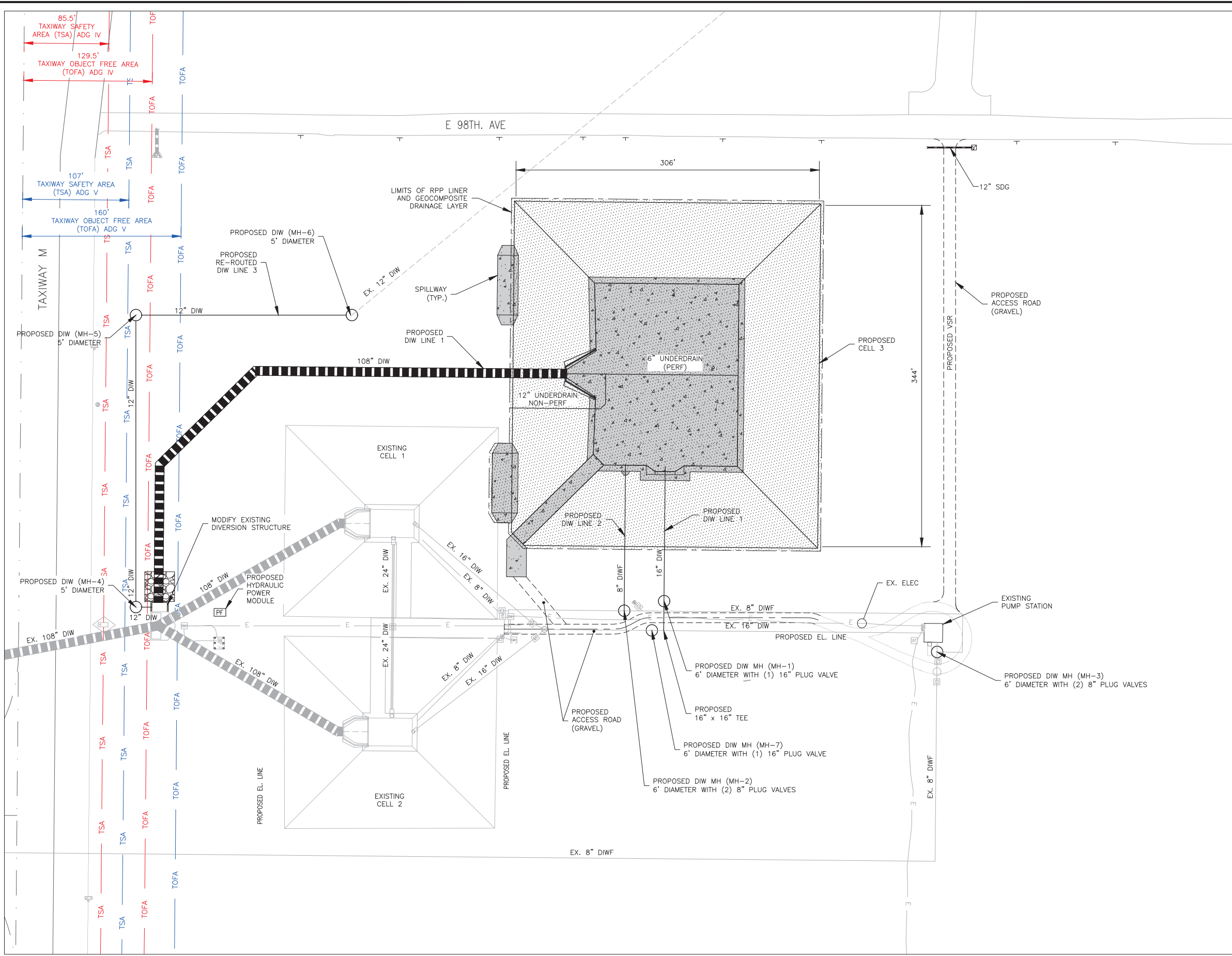

- LEGEND**
- PROPOSED CONCRETE PAVEMENT (6" FIBER REINFORCED)
  - PROPOSED RPP LINER AND GEOCOMPOSITE DRAINAGE LAYER
  - 5690 EXISTING INDEX CONTOUR
  - 5689 EXISTING INTERMEDIATE CONTOUR
  - 5690 PROPOSED INDEX CONTOUR
  - 5689 PROPOSED INTERMEDIATE CONTOUR
  - EXISTING (DIW) PIPE LARGE
  - EXISTING (DIW) PIPE SMALL
  - EXISTING ELECTRICAL LINE
  - PROPOSED (DIW) PIPE LARGE
  - PROPOSED (SDG) PIPE
  - PROPOSED (DIW) PIPE SMALL
  - PROPOSED 12" UNDERDRAIN NON-PERFORATED PIPE
  - PROPOSED 6" UNDERDRAIN PERFORATED PIPE
  - PROPOSED ELECTRICAL LINE
  - PROPOSED DIW MANHOLE
  - PROPOSED ELECTRICAL POWER FRAME

EXISTING UTILITY INFORMATION SHOWN IN THE PLANS ARE BASED ON SURVEY DATA AND AVAILABLE AS-BUILT DRAWINGS AND DO NOT NECESSARILY REPRESENT ALL EXISTING UTILITIES ON THE SITE. CONTRACTOR TO FIELD VERIFY LOCATION AND DEPTH OF EXISTING UTILITIES PRIOR TO COMMENCING CONSTRUCTION AND NOTIFY THE OWNER'S PROJECT MANAGER OF ANY DISCREPANCIES WHICH MAY CAUSE CONFLICTS.

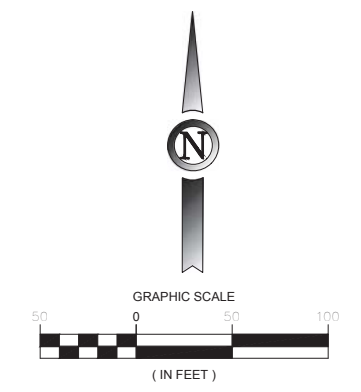

**POND 001 EXPANSION**

ISSUE RECORD

| NO. | BY  | PURPOSE | DATE   | CHKD |
|-----|-----|---------|--------|------|
| 1   | JBW | IFC     | 21NO17 |      |

SCALE

DATE APRIL 3, 2017

DRAWN BY: APA

CHECKED BY: JBW

FAA AIP NO. \_\_\_\_\_

WORK BREAKDOWN NO. \_\_\_\_\_

DESIGN CONTRACT NO. 201418360

CONST. CONTRACT NO. 201418360 TASK 5

VOLUME NO. 1

SHEET TITLE OVERALL SITE PLAN

SHEET NO. C0008

8 OF 61

CADD FILE NO. 201418360-TS-110GSP-008-POND-C0008



| ISSUE RECORD | NO. | BY  | PURPOSE | DATE   | CKD |
|--------------|-----|-----|---------|--------|-----|
| 1            | JBW | IFC |         | 21NO17 |     |

SCALE

DATE APRIL 3, 2017

DRAWN BY: APA

CHECKED BY: JBW

FAA AIP NO. \_\_\_\_\_

WORK BREAKDOWN NO. \_\_\_\_\_

DESIGN CONTRACT NO. 201418360

CONST. CONTRACT NO. 201418360 TASK 5

VOLUME NO. 1

SHEET TITLE

**BORING MAP  
AND  
BORING LOGS**

SHEET NO.

**C0009**  
9 OF 61

CADD FILE NO.  
\_201418360-T5-11GBLM-009-POND

LEGEND:

BORE LOCATION

| BORING LOG LOCATIONS |           |           |
|----------------------|-----------|-----------|
| BORE #               | NORTHING  | EASTING   |
| B-1                  | 198793.01 | 600293.41 |
| B-2                  | 198956.40 | 600310.82 |
| B-3                  | 198974.21 | 600616.19 |
| B-4                  | 199126.23 | 600735.26 |
| B-5                  | 198962.64 | 600885.76 |
| B-6                  | 198780.87 | 600740.23 |

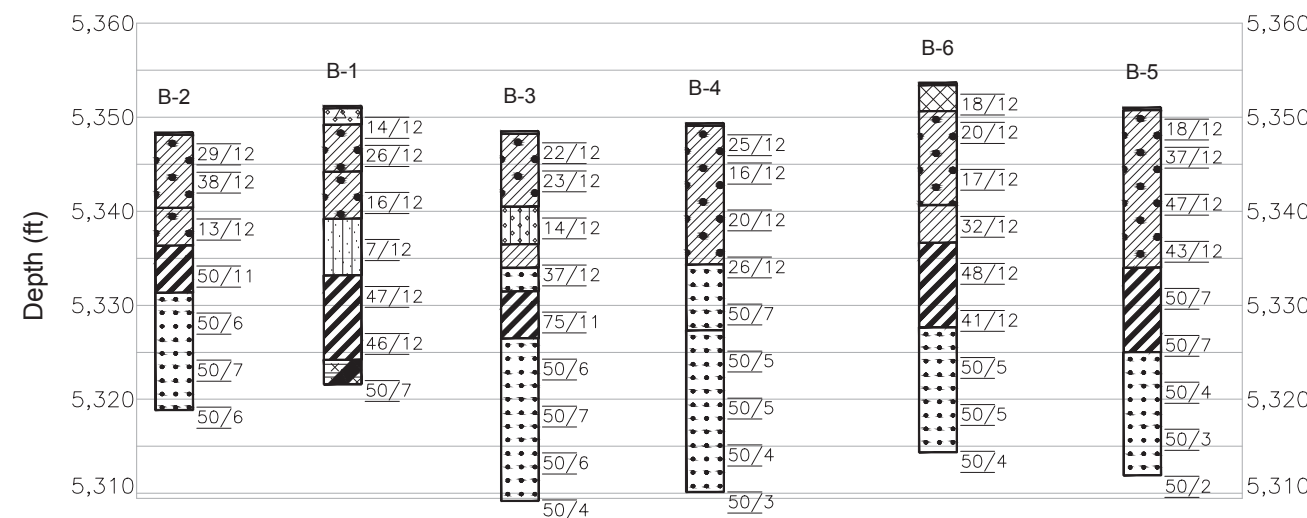
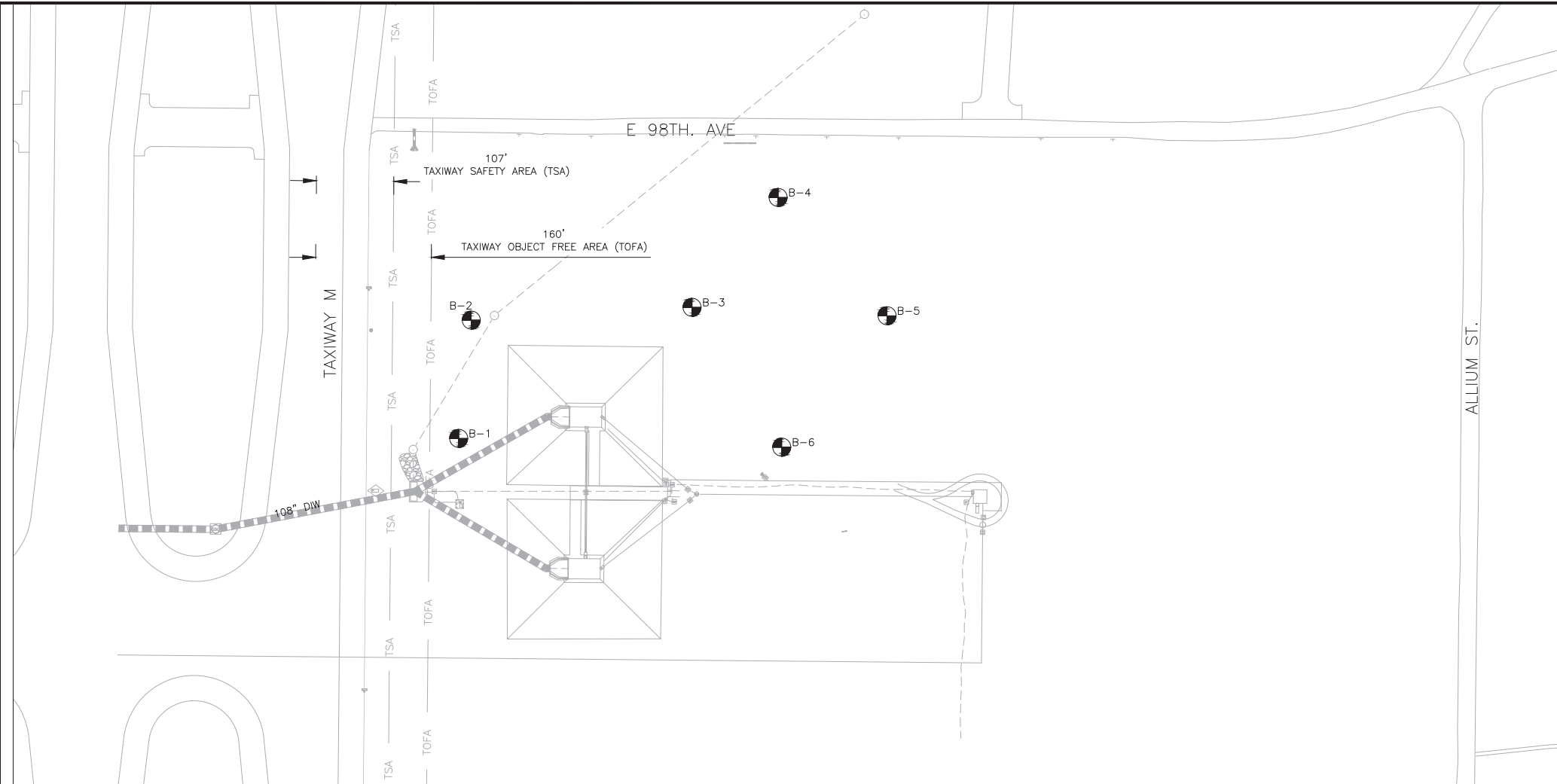
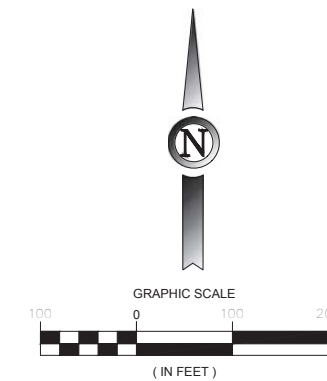

LEGEND

**LITHOLOGY**

|  |   |  |                      |
|--|---|--|----------------------|
|  | FILL - CLAY                               |  | FILL - SAND          |
|  | TOPSOIL                                   |  | NATIVE - SAND, SILTY |
|  | NATIVE - CLAY                             |  | NATIVE - CLAY, SANDY |
|  | NATIVE - SILT, SANDY                      |  | BEDROCK - CLAYSTONE  |
|  | BEDROCK - INTERBEDDED CLAYSTONE/SANDSTONE |  | BEDROCK - SANDSTONE  |

**SAMPLE TYPE**

|  |                |  |  |
|--|----------------|--|--|
|  | AUGER CUTTINGS |  | MODIFIED CALIFORNIA SAMPLER<br>2.5" O.D. AND 2" I.D. WITH<br>BRASS LINERS INCLUDED |
|--|----------------|--|--|

15/12 INDICATES 15 BLOWS OF A 140 POUND HAMMER FALLING 30 INCHES WAS REQUIRED TO DRIVE THE SAMPLER 12 INCHES.  
 30/11 INDICATES 30 BLOWS OF A 140 POUND HAMMER FALLING 30 INCHES WAS REQUIRED TO DRIVE THE SAMPLER 11 INCHES.  
 5,5,5 INDICATES 5 BLOWS, 5 BLOWS, 5 BLOWS OF A 140 POUND HAMMER FALLING 30 INCHES WAS REQUIRED TO DRIVE THE SAMPLER 18 INCHES.  
 SR INDICATES SAMPLER REBOUND  
 GROUND WATER LEVEL NOTED AT THE TIME OF DRILLING

L:\014\201418360 DWI Pond 001 Expansion Design\CAD\PLANS\201418360-T5-11GBLM-009-POND.dwg Nov 21, 2017 - 12:16pm jmas.morehead





POND 001 EXPANSION

| NO. | BY  | PURPOSE | DATE   | CHKD |
|-----|-----|---------|--------|------|
| 1   | JBW | IFC     | 21NO17 |      |

SCALE

DATE APRIL 3, 2017

DRAWN BY: APA

CHECKED BY: JBW

FAA AIP NO:

WORK BREAKDOWN NO:

DESIGN CONTRACT NO.

201418360

CONST. CONTRACT NO.

201418360 TASK 5

VOLUME NO.

1

SHEET TITLE

GRADING PLAN

SHEET NO.

C0200

11 OF 61

CADD FILE NO.

\_201418360-T5-1CGRA-101-POND

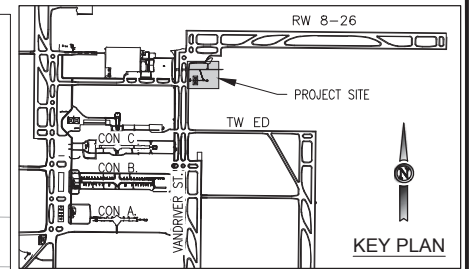

**GRADING LEGEND**

- PROPOSED CONCRETE PAVEMENT (6" FIBER REINFORCED)
- PROPOSED RPP LINER AND GEOCOMPOSITE DRAINAGE LAYER
- 5690 EXISTING INDEX CONTOUR
- 5690 PROPOSED INDEX CONTOUR
- 5689 PROPOSED INTERMEDIATE CONTOUR
- EXISTING (DIW) PIPE LARGE
- EXISTING (DIW) PIPE SMALL
- EXISTING ELECTRICAL LINE
- PROPOSED (DIW) PIPE LARGE
- SDG PROPOSED (SDG) PIPE
- DIW PROPOSED (DIW) PIPE SMALL
- NON-PERF PROPOSED 12" UNDERDRAIN NON-PERFORATED PIPE
- PERF PROPOSED 6" UNDERDRAIN PERFORATED PIPE
- E PROPOSED ELECTRICAL LINE
- PROPOSED DIW MANHOLE
- PROPOSED ELECTRICAL POWER FRAME

- NOTES:**
- CONTRACTOR TO COORDINATE WITH DEN PROJECT MANAGER FOR ALL CONNECTIONS TO EXISTING SYSTEMS. UNDER NO CIRCUMSTANCES WILL THE CONTRACTOR OPERATE ANY VALVES OR GATES.
  - PROPOSED CONTOURS REPRESENT FINAL DESIGN ELEVATIONS. PROPOSED CONTOURS IN CONCRETE PAVEMENT AREAS REPRESENT THE TOP OF RPP LINER. TOP OF CONCRETE IS 6" ABOVE ELEVATIONS SHOWN ON THIS SHEET.
  - EXISTING UTILITIES SHALL BE PROTECTED FROM INFILTRATION OF DEBRIS FROM CONSTRUCTION ACTIVITIES RELATED TO GRADING ACTIVITIES.
  - SEE SHEETS C0400 - C0401 FOR TYPICAL SECTIONS.
  - SEE SHEETS C0550 TO C0554 FOR DETAILS.

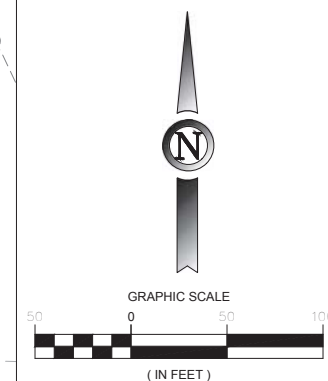
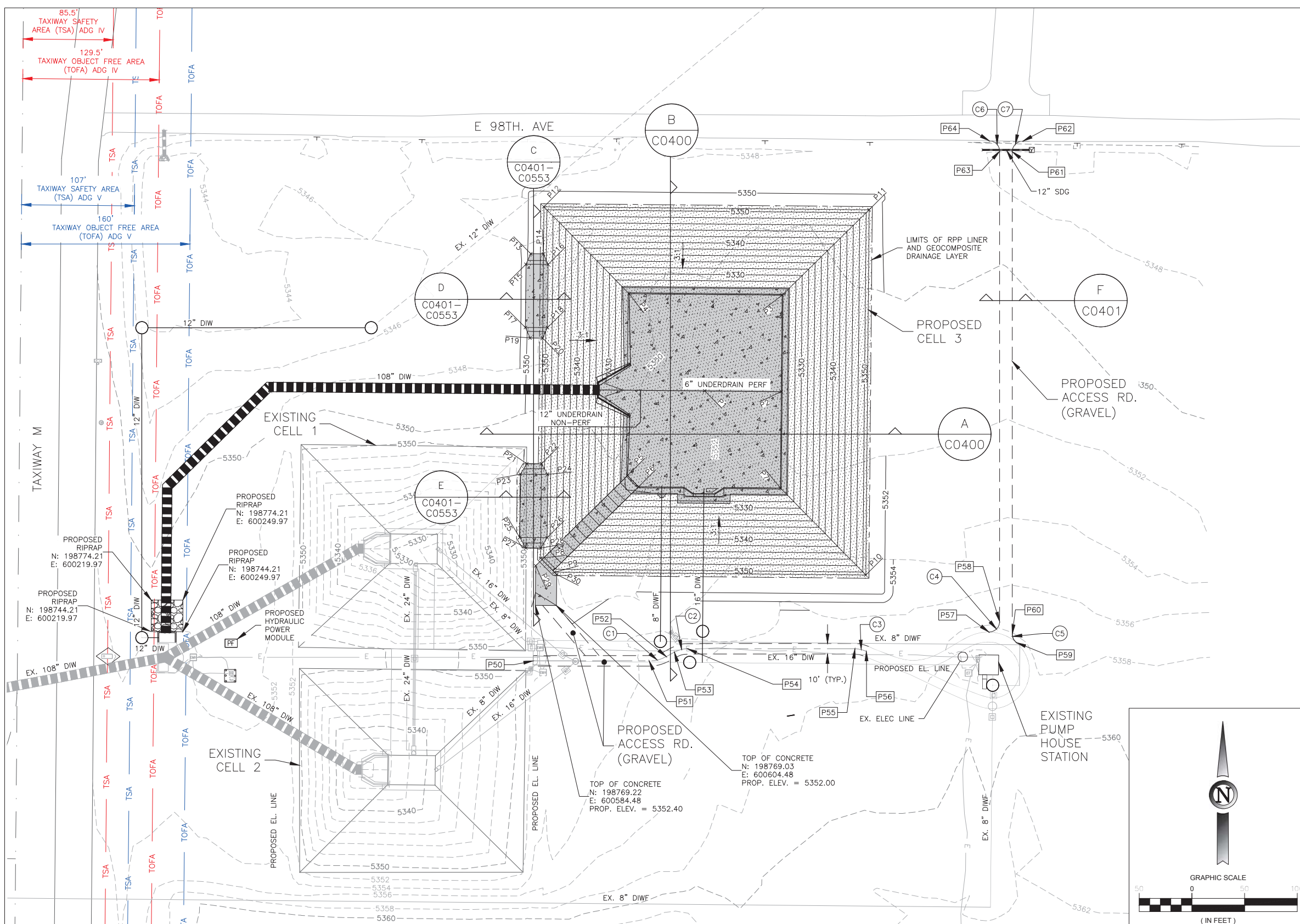

| SPOT ELEVATION TABLE |            |            |                    | SPOT ELEVATION TABLE |            |            |                    | SPOT ELEVATION TABLE |            |            |                    | SPOT ELEVATION TABLE |            |            |                    | SPOT ELEVATION TABLE |            |            |                    | SPOT ELEVATION TABLE |            |            |                    |
|----------------------|------------|------------|--------------------|----------------------|------------|------------|--------------------|----------------------|------------|------------|--------------------|----------------------|------------|------------|--------------------|----------------------|------------|------------|--------------------|----------------------|------------|------------|--------------------|
| POINT                | NORTHING   | EASTING    | PROPOSED ELEVATION | POINT                | NORTHING   | EASTING    | PROPOSED ELEVATION | POINT                | NORTHING   | EASTING    | PROPOSED ELEVATION | POINT                | NORTHING   | EASTING    | PROPOSED ELEVATION | POINT                | NORTHING   | EASTING    | PROPOSED ELEVATION | POINT                | NORTHING   | EASTING    | PROPOSED ELEVATION |
| P1                   | 198,972.67 | 600,745.31 | 5323.10            | P6                   | 198,881.65 | 600,682.53 | 5323.70            | P11                  | 199,144.59 | 600,901.31 | 5350.95            | P16                  | 199,092.69 | 600,596.62 | 5349.45            | P21                  | 198,903.59 | 600,576.37 | 5350.95            | P26                  | 198,833.41 | 600,595.72 | 5348.95            |
| P2                   | 198,972.00 | 600,817.96 | 5323.70            | P7                   | 198,880.40 | 600,817.11 | 5323.70            | P12                  | 199,147.44 | 600,592.62 | 5350.95            | P17                  | 199,032.88 | 600,575.06 | 5349.45            | P22                  | 198,903.46 | 600,590.37 | 5350.95            | P27                  | 198,823.59 | 600,575.63 | 5350.95            |
| P3                   | 199,063.59 | 600,818.81 | 5323.70            | P8                   | 198,813.91 | 600,589.54 | 5350.95            | P13                  | 199,102.84 | 600,580.21 | 5350.95            | P18                  | 199,032.69 | 600,596.06 | 5349.45            | P23                  | 198,893.65 | 600,570.28 | 5348.95            | P28                  | 198,823.46 | 600,589.63 | 5350.95            |
| P4                   | 199,064.94 | 600,673.41 | 5323.70            | P9                   | 198,800.63 | 600,602.57 | 5350.95            | P14                  | 199,102.73 | 600,592.21 | 5350.95            | P19                  | 199,022.84 | 600,579.47 | 5350.95            | P24                  | 198,893.41 | 600,596.27 | 5348.95            | P29                  | 198,806.75 | 600,584.82 | 5351.15            |
| P5                   | 198,892.35 | 600,672.02 | 5323.70            | P10                  | 198,797.90 | 600,898.11 | 5350.95            | P15                  | 199,092.88 | 600,575.62 | 5349.45            | P20                  | 199,022.73 | 600,591.47 | 5350.95            | P25                  | 198,833.65 | 600,569.72 | 5348.95            | P30                  | 198,798.41 | 600,604.75 | 5351.02            |

**NOTE:**  
 1. ELEVATIONS SHOWN IN THIS TABLE REPRESENT TOP OF RPP LINER. TOP OF CONCRETE IS 6" ABOVE ELEVATIONS SHOWN ON THIS SHEET.

L:\DIA\201418360 Dwg Pond 001 Expansion Design\CADD\PLANS\201418360-T5-1CGRA-101-POND.dwg Nov 21, 2017 - 12:16pm jmes.morehead

L:\DIA\201418360 DWG Pond 001 Expansion Design\CAD\PLANS\201418360-T5-1CJTP-101-POND.dwg Nov 21, 2017 - 12:17pm jmesmorehead

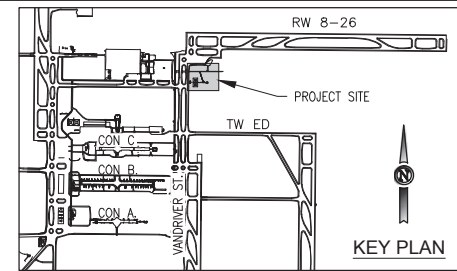
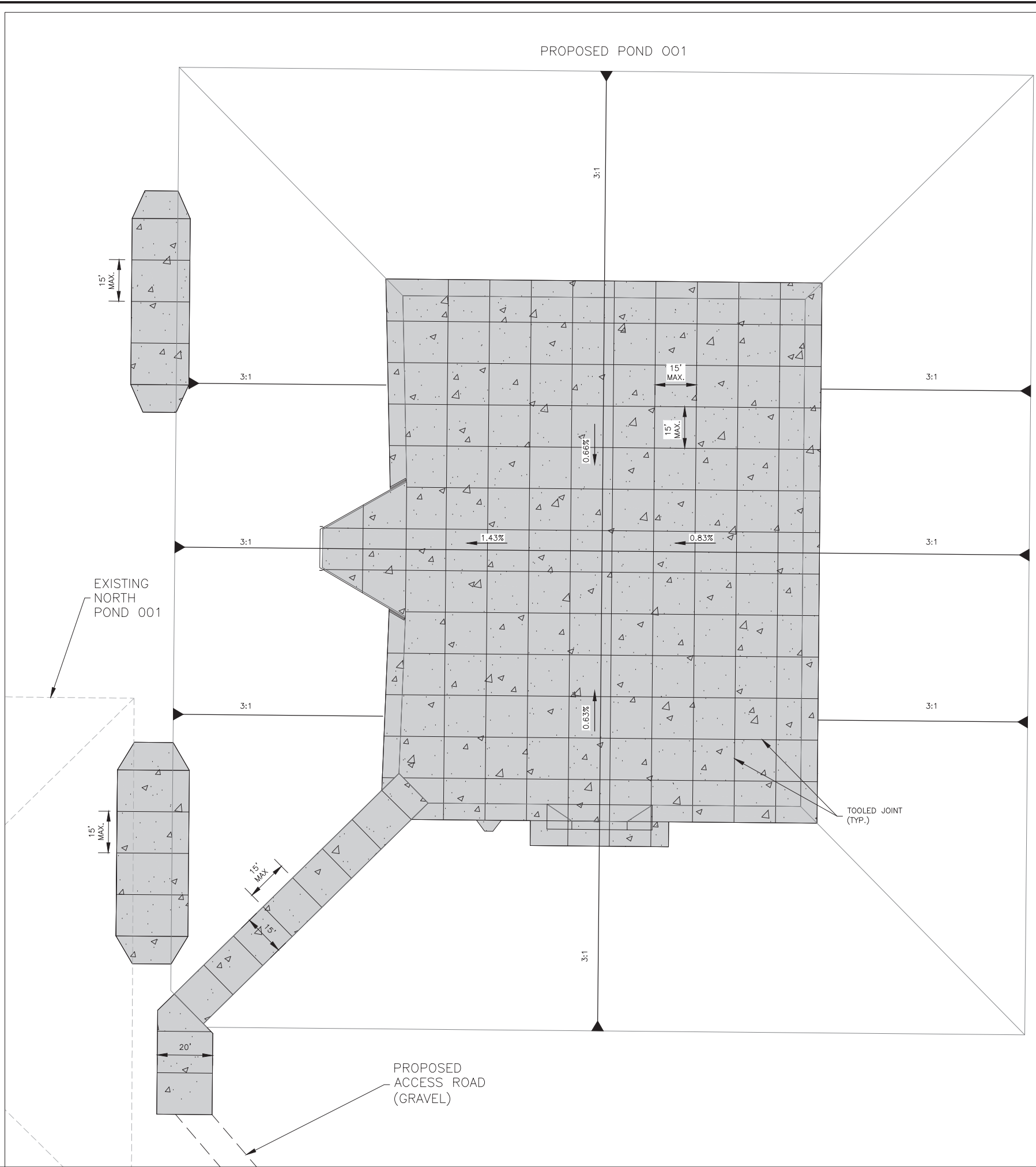

**LEGEND:**

PROPOSED CONCRETE PAVEMENT  
(6" FIBER REINFORCED), (P-610)

**JOINT NOTES:**

- SEE SHEETS C0553 FOR TOOLED JOINT DETAIL..

CITY & COUNTY  
of DENVER

DENVER  
INTERNATIONAL  
AIRPORT



**AVIATION**

**POND 001 EXPANSION**

| NO. | BY  | PURPOSE | DATE   | CKD |
|-----|-----|---------|--------|-----|
| 1   | JBW | IFC     | 21NO17 |     |

**SCALE**

DATE: APRIL 3, 2017

DRAWN BY: APA

CHECKED BY: JBW

FAA AIP NO:

WORK BREAKDOWN NO:

DESIGN CONTRACT NO: 201418360

CONST. CONTRACT NO: 201418360 TASK 5

VOLUME NO: 1

SHEET TITLE

**JOINT  
PLAN**

SHEET NO:

**C0300**

12 OF 61

CADD FILE NO:

\_201418360-T5-1CJTP-101-POND

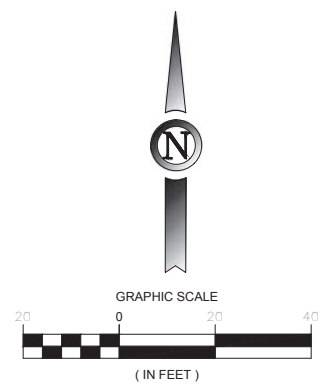





POND 001 EXPANSION

ISSUE RECORD

NO. BY PURPOSE DATE CKD

1 JBW IFC 21NO17

SCALE

DATE

APRIL 3, 2017

DRAWN BY:

APA

CHECKED BY:

JBW

FAA AIP NO:

WORK BREAKDOWN NO.

DESIGN CONTRACT NO.

201418360

CONST. CONTRACT NO.

201418360 TASK 5

VOLUME NO.

1

SHEET TITLE

TYPICAL

SECTIONS

SHEET NO.

C0400

13 OF 61

CADD FILE NO.

\_201418360-T5-11CTYP-101-POND

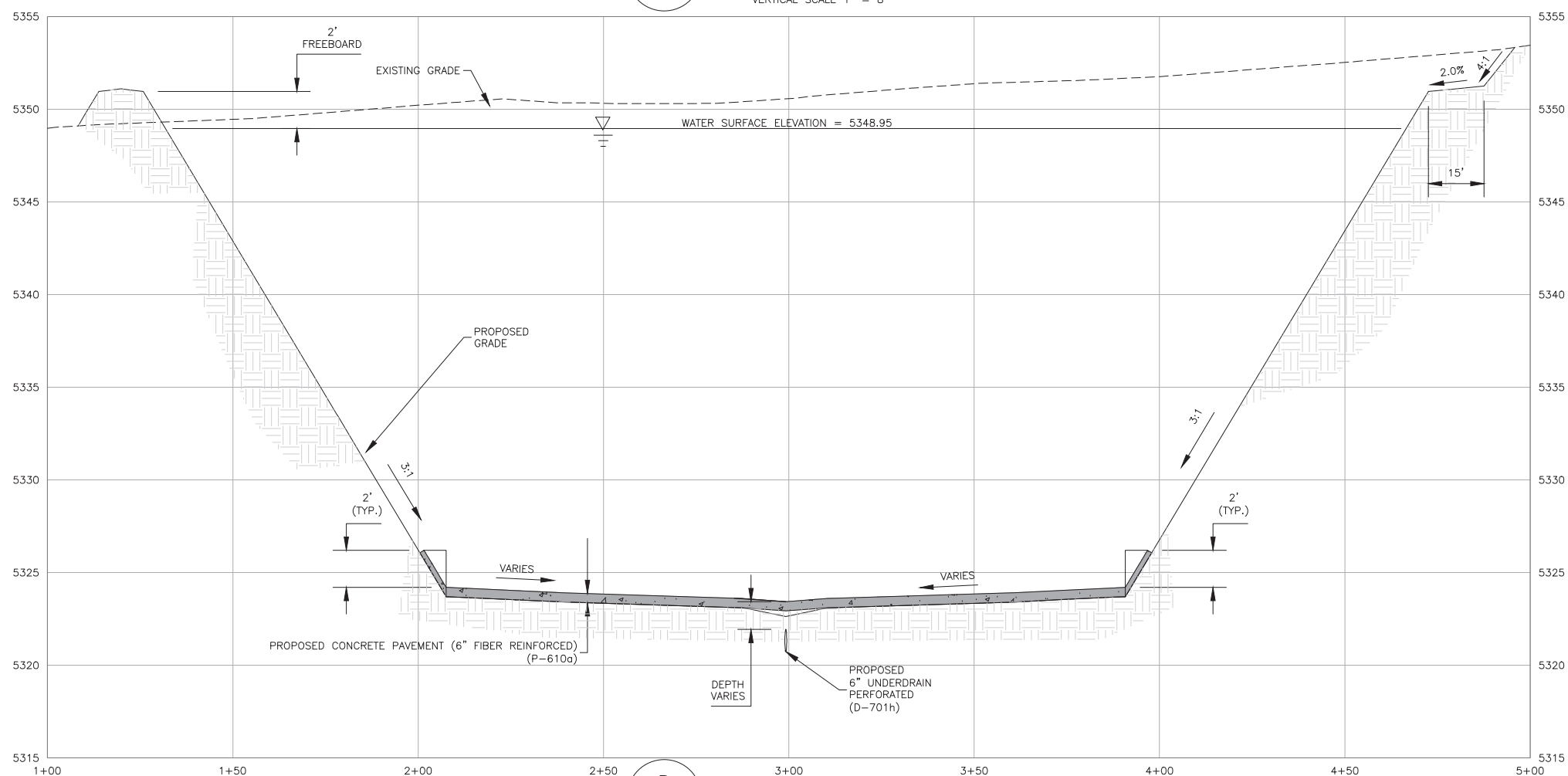
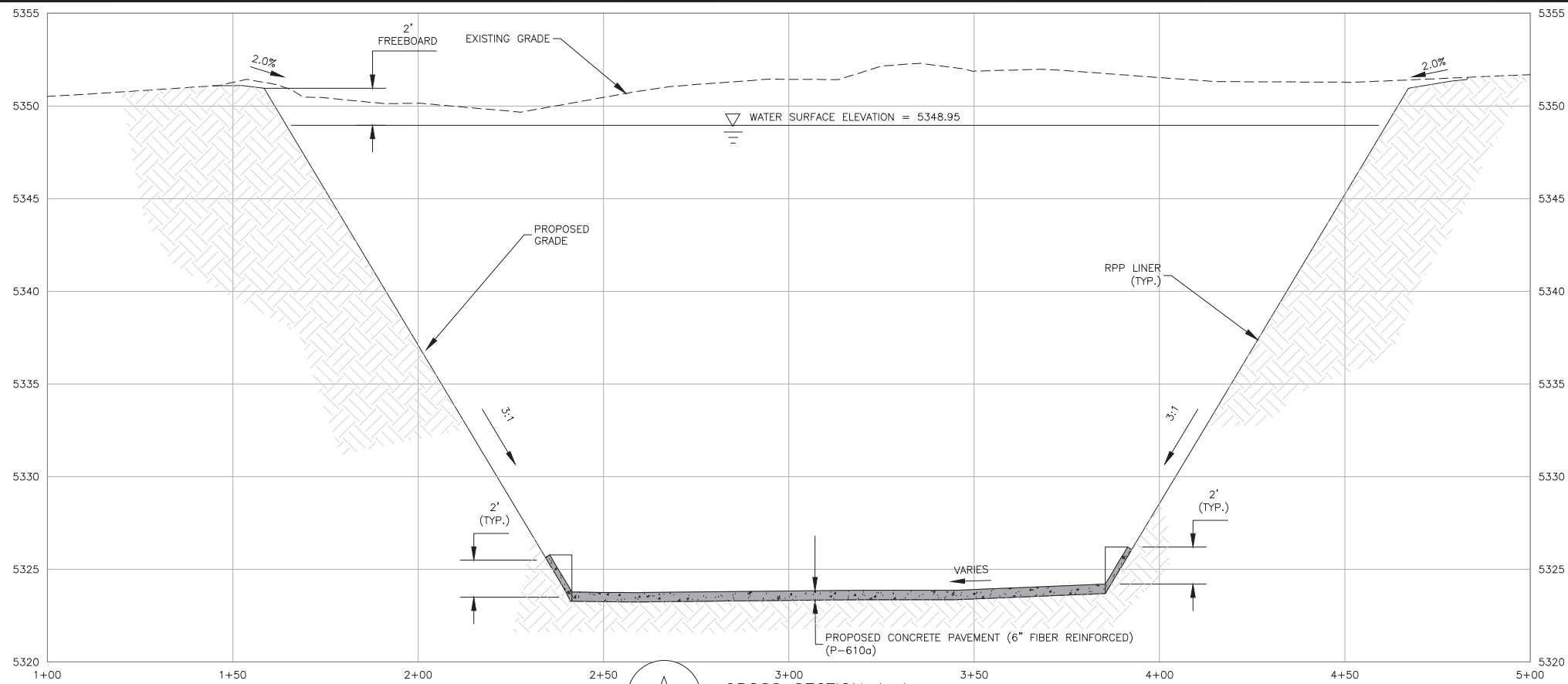

L:\014\201418360 DWI Pond 001 Expansion Design\CAD\PLANS\201418360-T5-11CTYP-101-POND.dwg Nov 21, 2017 - 12:17pm jmesmorehead



POND 001 EXPANSION

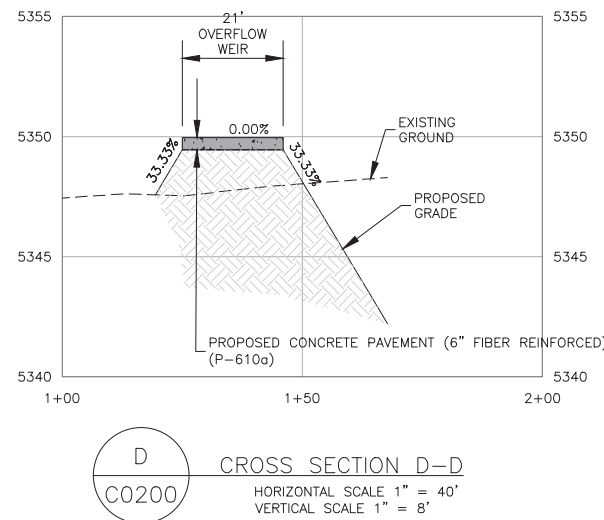
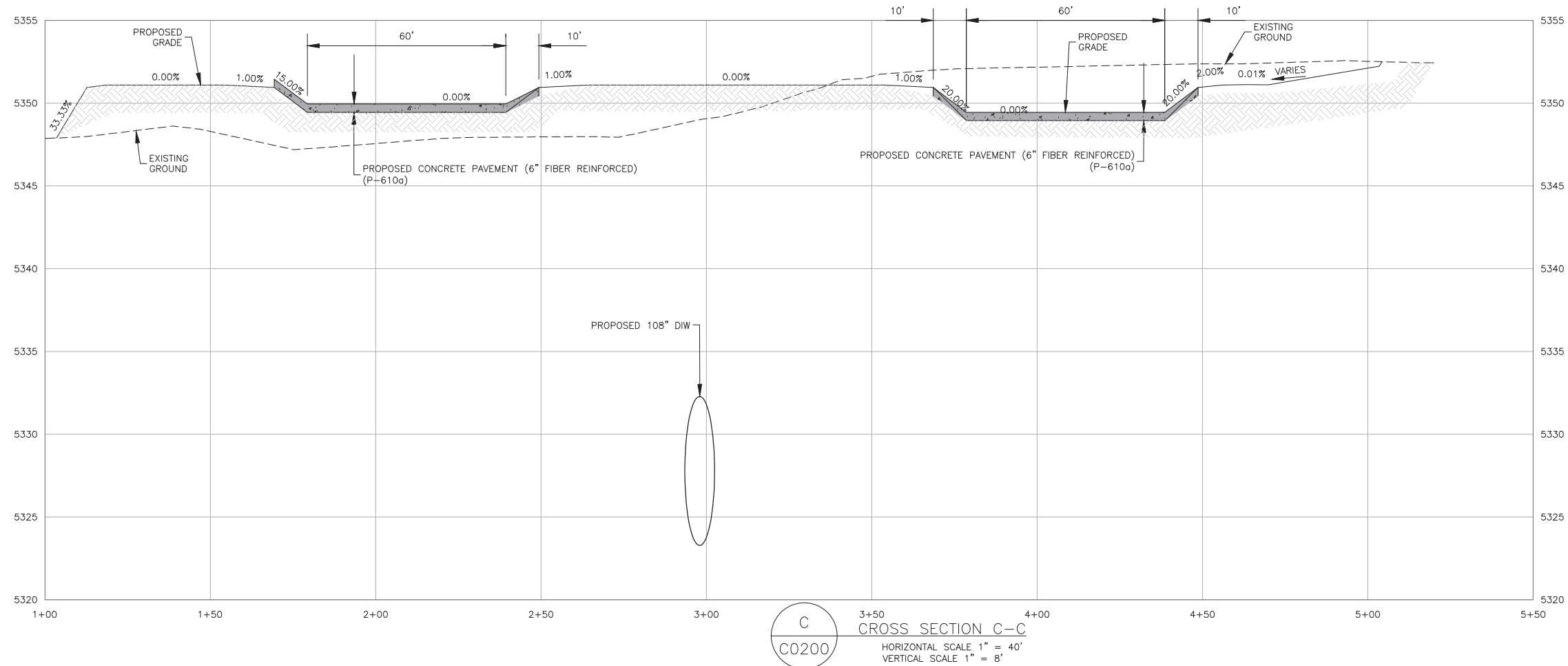

NOTE  
SEE DETAILS D AND F, SHEET C0553 FOR ADDITIONAL  
INFORMATION.

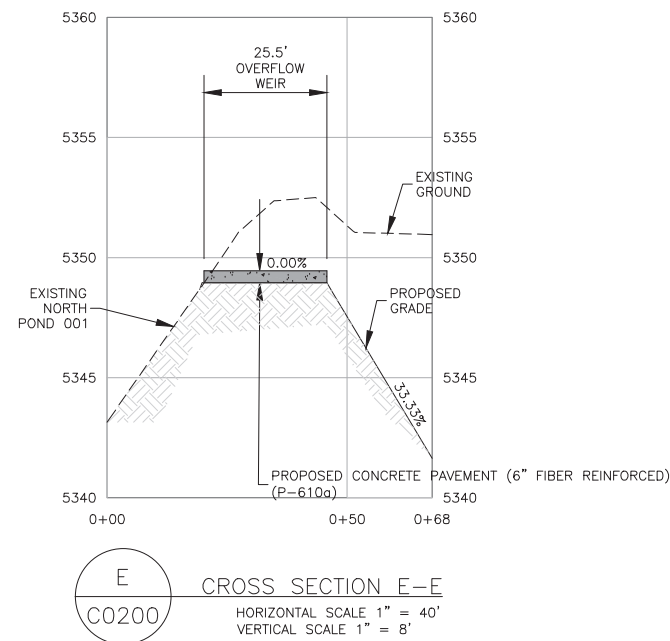

NOTE  
SEE DETAILS D AND F, SHEET C0553 FOR ADDITIONAL  
INFORMATION.

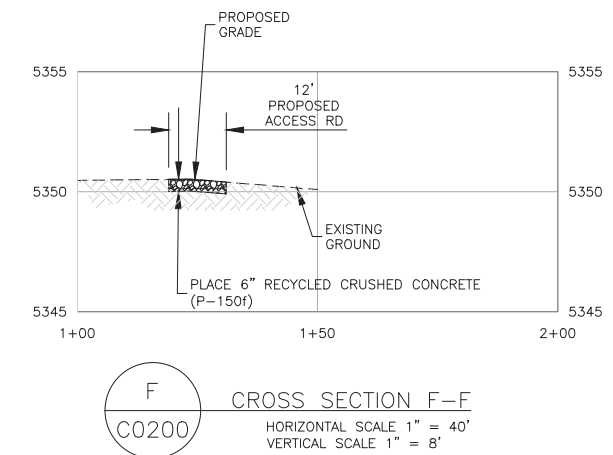

ISSUE RECORD

| NO. | BY  | PURPOSE | DATE   | CKD |
|-----|-----|---------|--------|-----|
| 1   | JBW | IFC     | 21NO17 |     |

SCALE

DATE: APRIL 3, 2017

DRAWN BY: APA

CHECKED BY: JBW

FAA AIP NO.

WORK BREAKDOWN NO.

DESIGN CONTRACT NO. 201418360

CONST. CONTRACT NO. 201418360 TASK 5

VOLUME NO. 1

TYPICAL  
SECTIONS

SHEET NO. C0401  
14 OF 61  
CADD FILE NO. \_201418360-T5-11CTYP-102-POND - 040



| NO. | BY  | PURPOSE | DATE   | CHKD |
|-----|-----|---------|--------|------|
| 1   | JBW | IFC     | 21NO17 |      |

SCALE

DATE

APRIL 3, 2017

DRAWN BY: APA

CHECKED BY: JBW

FAA AIP NO:

WORK BREAKDOWN NO.

DESIGN CONTRACT NO.

201418360

CONST. CONTRACT NO.

201418360 TASK 5

VOLUME NO.

1

SHEET TITLE

UTILITY

PLAN

SHEET NO.

C0500

15 OF 61

CADD FILE NO.

\_201418360-T5-11CUTP-101-POND-C0500

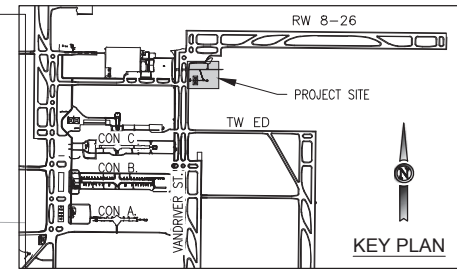

UTILITY LEGEND

- PROPOSED CONCRETE PAVEMENT (6" FIBER REINFORCED), (P-610)
- PROPOSED RPP LINER AND GEOCOMPOSITE DRAINAGE LAYER
- EXISTING (DIW) PIPE LARGE
- EXISTING (DIW) PIPE SMALL
- EXISTING ELECTRICAL LINE
- PROPOSED (DIW) PIPE LARGE
- PROPOSED (SDG) PIPE
- PROPOSED (DIW) PIPE SMALL
- PROPOSED 12" UNDERDRAIN NON-PERFORATED PIPE
- PROPOSED 6" UNDERDRAIN PERFORATED PIPE
- PROPOSED ELECTRICAL LINE
- PROPOSED DIW MANHOLE
- PROPOSED ELECTRICAL POWER FRAME

NOTES:

1. THE CONTRACTOR SHALL FIELD LOCATE AND POTHOLE DIW FORCE MAIN AT LOCATION OF MANHOLES MH-2 AND MH-3 PRIOR TO ORDERING MATERIALS. THE CONTRACTOR SHALL NOTIFY THE DEN PROJECT MANAGER OF ANY DISCREPANCIES, BETWEEN DESIGN AND FIELD CONDITIONS.
2. THE CONTRACTOR SHALL OVER-EXCAVATE A MINIMUM OF 3 FEET OF MATERIAL UNDERNEATH MANHOLES MH-2, MH-3, MH-4, MH-5 AND MH-6. THE EXCAVATED MATERIAL SHALL BE REPLACED WITH A MINIMUM OF 3 FEET OF FLOWABLE BACKFILL PER P-153.
3. THE CONTRACTOR SHALL EPOXY COAT THE INTERIOR OF MANHOLES MH-1, MH-2, MH-3, AND MH-7. EPOXY COATING SHALL BE PER THE REQUIREMENTS OF SPECIFICATION D-751.
4. ALL PIPING INSIDE NEW VALVE MANHOLES SHALL BE DUCTILE IRON. DUCTILE IRON PIPE SHALL EXTEND A MINIMUM OF 5 FEET BEYOND EXTERIOR WALL OF VALVE MANHOLES BEFORE TRANSITIONING TO NEW OR EXISTING PVC PIPE.
5. ALL PIPE JOINTS SHALL BE FULLY RESTRAINED TYPE.
6. ALL BURIED DUCTILE IRON PIPE SHALL BE POLYETHYLENE WRAPPED. REFER TO SPECIFICATION D-701 FOR MORE INFORMATION.

EXISTING UTILITY INFORMATION SHOWN IN THE PLANS ARE BASED ON SURVEY DATA AND AVAILABLE AS-BUILT DRAWINGS AND DO NOT NECESSARILY REPRESENT ALL EXISTING UTILITIES ON THE SITE. CONTRACTOR TO FIELD VERIFY LOCATION AND DEPTH OF EXISTING UTILITIES PRIOR TO COMMENCING CONSTRUCTION AND NOTIFY THE OWNER'S PROJECT MANAGER OF ANY DISCREPANCIES WHICH MAY CAUSE CONFLICTS.

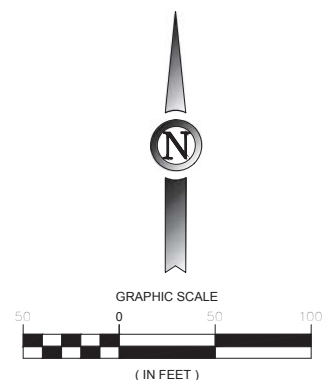

2" SDG POINT TABLE - UNDERDRAIN

| POINT | NORTHING   | EASTING    | PROPOSED INVERT ELEVATION | TYPE          |
|-------|------------|------------|---------------------------|---------------|
| P1    | 198,939.15 | 600,587.70 | *SEE BELOW                | 12" END       |
| P2    | 198,938.33 | 600,673.90 | 5318.68                   | 12" LOW POINT |
| P3    | 198,938.28 | 600,679.24 | 5318.79                   | 12" BEND      |
| P4    | 198,943.23 | 600,684.29 | 5318.75                   | 12" BEND      |
| P5    | 198,973.23 | 600,684.57 | 5318.90                   | 6" x 12" TEE  |
| P6    | 198,973.60 | 600,644.97 | 5319.14                   | 6" END        |
| P7    | 198,972.00 | 600,817.96 | 5321.70                   | 6" END        |

\*UNDERDRAIN SHALL EXTEND THROUGH RPP LINER AND TERMINATE ABOVE GRADE AT LOCATION INDICATED, SEE DETAIL 6, SHEET C0550.

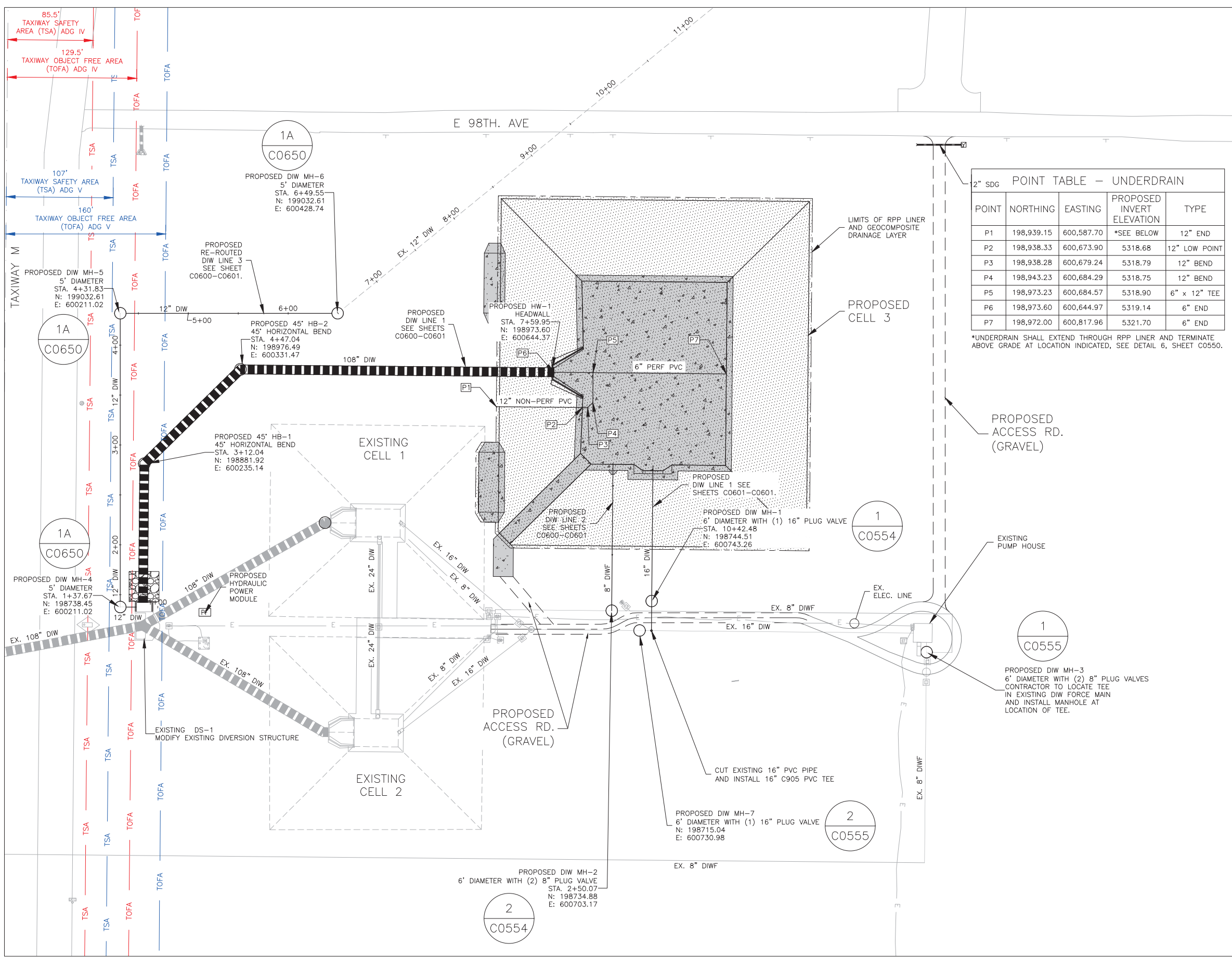

L:\DIA\201418360 DIW Pond 001 Expansion Design\CADD\PLANS\201418360-T5-11CUTP-101-POND-C500.dwg Nov 21, 2017 - 12:18pm james.morehead



| ISSUE NO. | BY  | PURPOSE | DATE   | CHKD |
|-----------|-----|---------|--------|------|
| 1         | JBW | IFC     | 21NO17 |      |

SCALE

DATE: APRIL 3, 2017

DRAWN BY: APA

CHECKED BY: JBW

FAA AIP NO.

WORK BREAKDOWN NO.

DESIGN CONTRACT NO. 201418360

CONST. CONTRACT NO. 201418360 TASK 5

VOLUME NO. 1

SHEET TITLE

CIVIL DETAILS

SHEET NO. C0550

16 OF 61

CADD FILE NO. \_201418360-T5-11CDET-501-POND-C0550

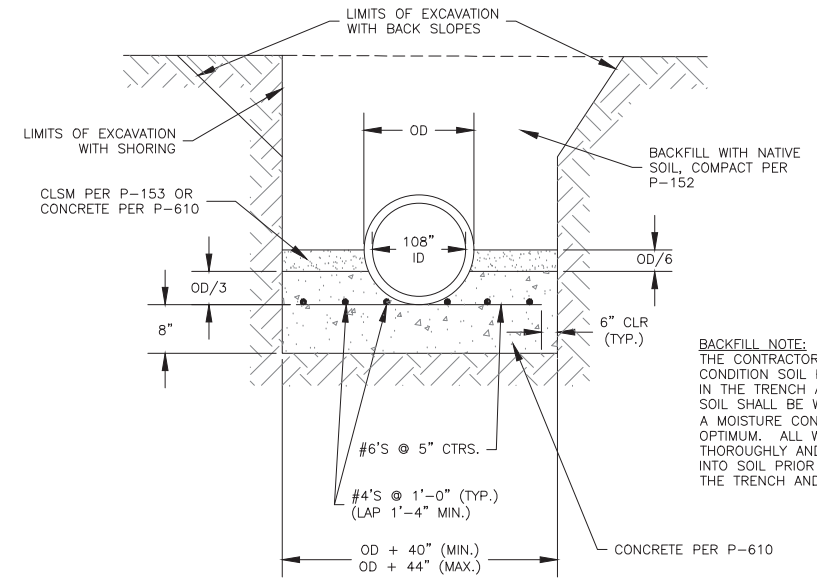
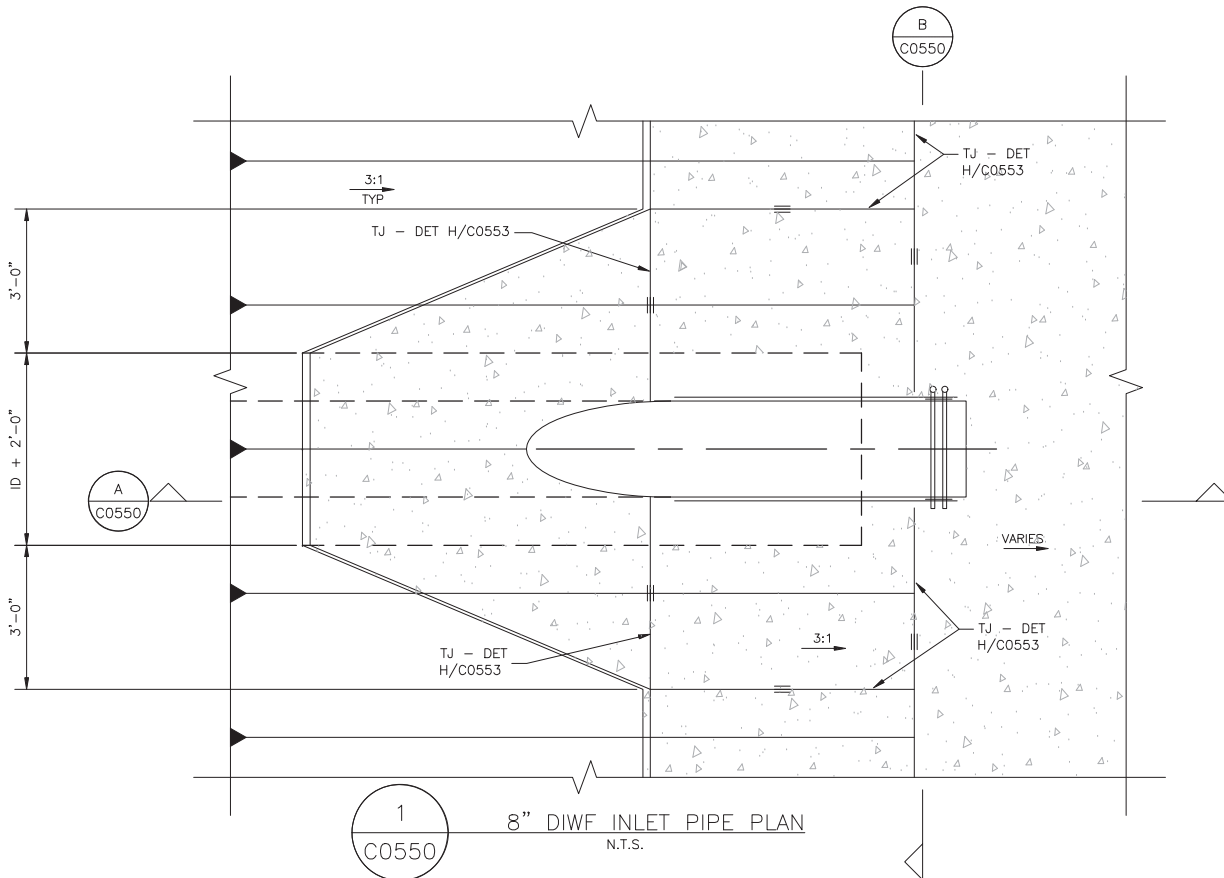
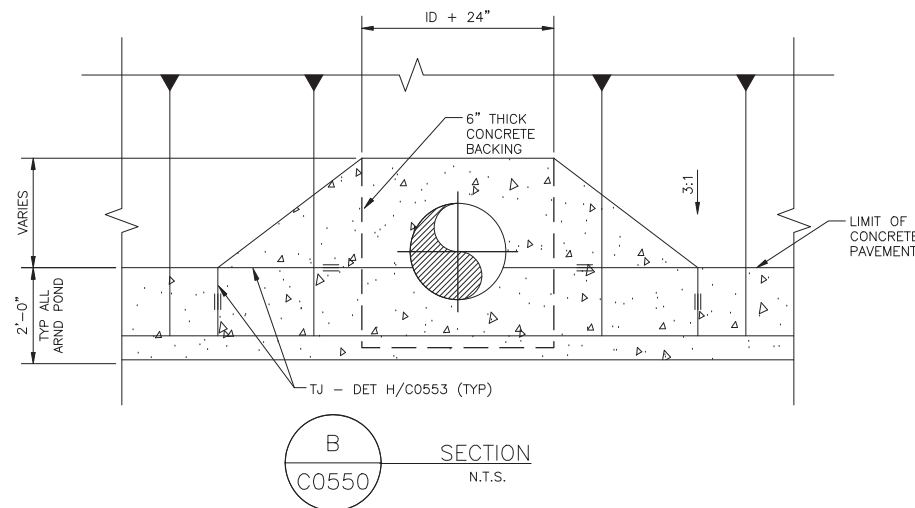
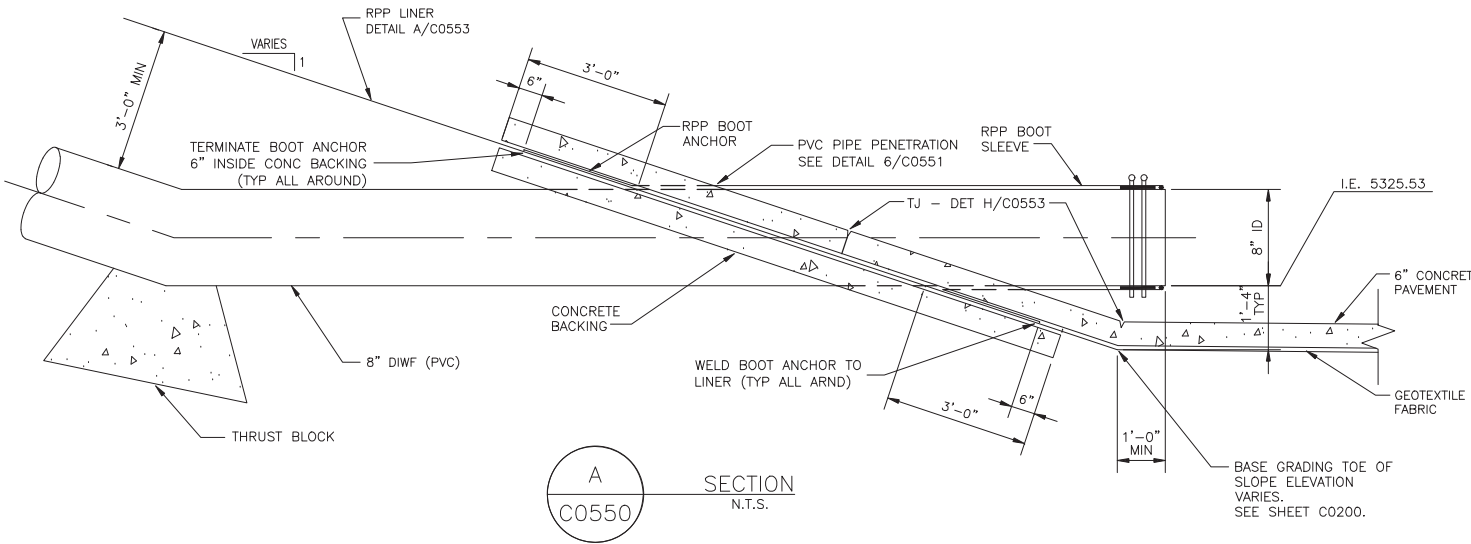

NOTE: THIS DETAIL SHALL BE USED FOR INSTALLATION OF 108" DIW CLASS IV RCP.

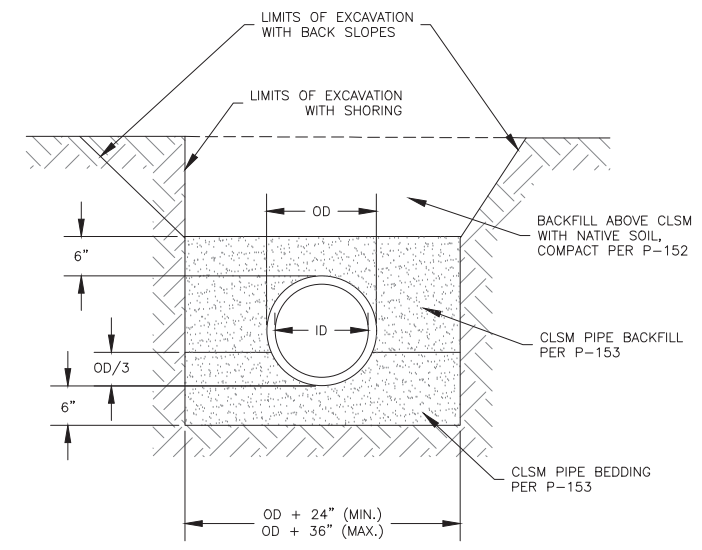

NOTE: THIS DETAIL SHALL BE USED FOR INSTALLATION OF 8", 12", & 16" PVC PIPE AND 12" RCP.

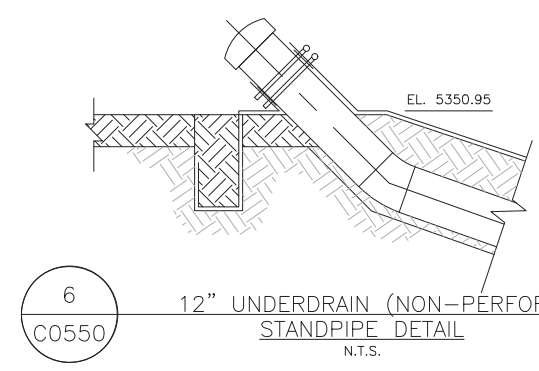
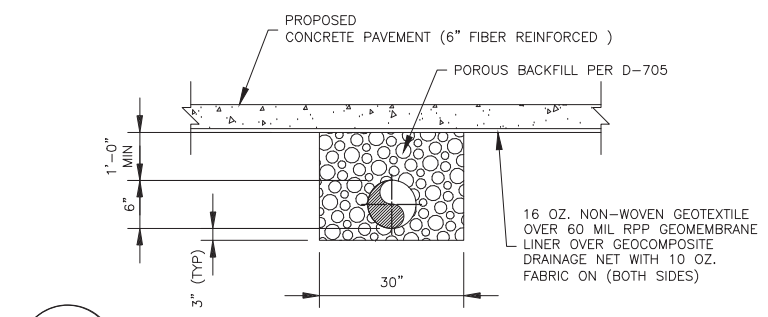
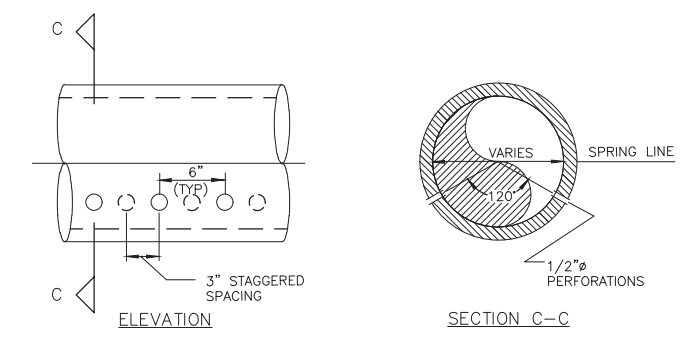

L:\014\201418360 DIWF Pond 001 Expansion Design\CAD\PLANS\201418360-T5-11CDET-501-POND-C0550.dwg Nov 21, 2017 12:18pm James.mcrehead



ISSUE RECORD

| NO. | BY  | PURPOSE | DATE   | CKD |
|-----|-----|---------|--------|-----|
| 1   | JBW | IFC     | 21NO17 |     |

SCALE

DATE: APRIL 3, 2017

DRAWN BY: APA

CHECKED BY: JBW

FAA AIP NO:

WORK BREAKDOWN NO:

DESIGN CONTRACT NO: 201418360

CONST. CONTRACT NO: 201418360 TASK 5

VOLUME NO: 1

SHEET TITLE

CIVIL  
DETAILS

SHEET NO: C0551

17 OF 61

CADD FILE NO: \_201418360-T5-11CDET-502-POND-C0551

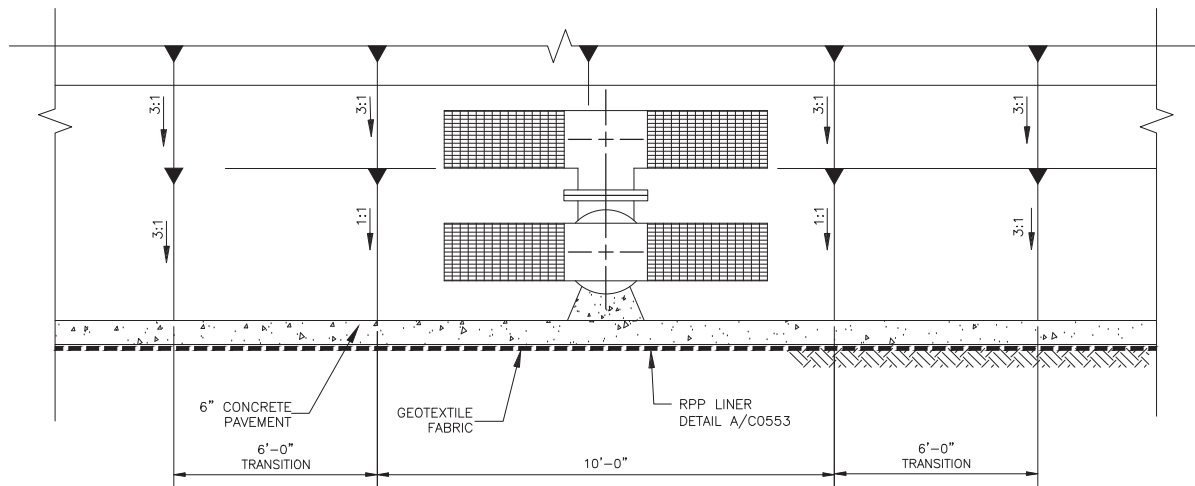

A SECTION  
C0551 N.T.S.

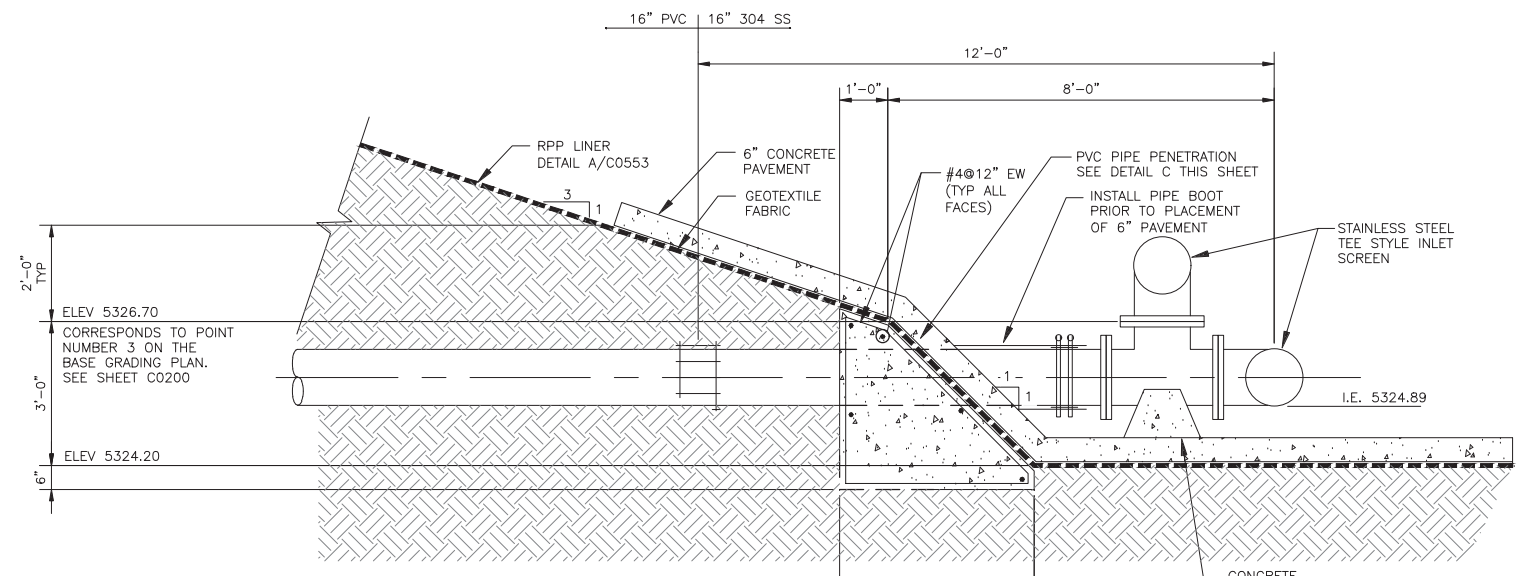

B SECTION  
C0551 N.T.S.

NOTE:  
1. RPP SURFACE CORRESPONDS TO SURFACE REPRESENTED BY THE BASE GRADING PLAN ON SHEET C0200.

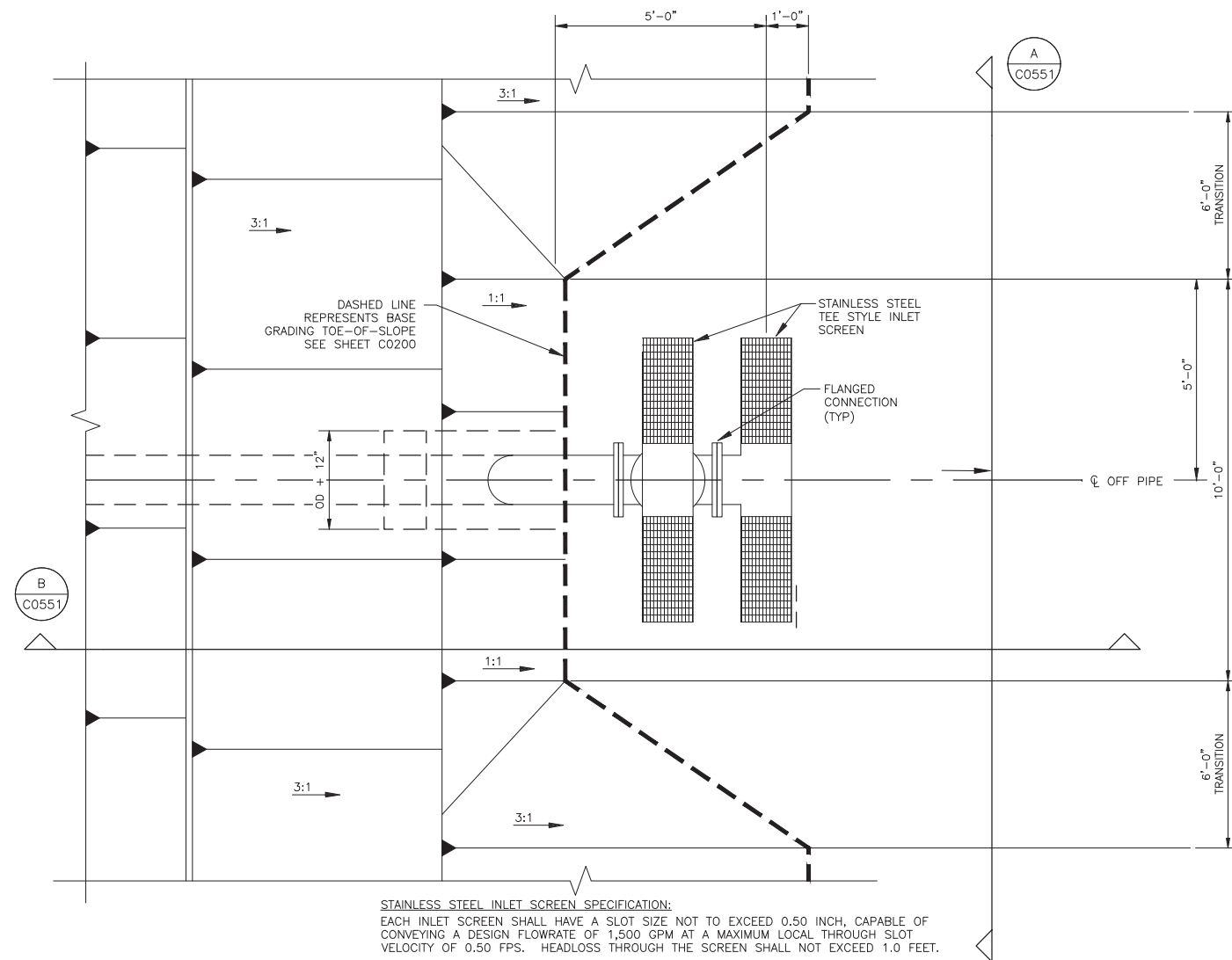

B SECTION  
C0551

STAINLESS STEEL INLET SCREEN SPECIFICATION:  
EACH INLET SCREEN SHALL HAVE A SLOT SIZE NOT TO EXCEED 0.50 INCH, CAPABLE OF CONVEYING A DESIGN FLOWRATE OF 1,500 GPM AT A MAXIMUM LOCAL THROUGH SLOT VELOCITY OF 0.50 FPS. HEADLOSS THROUGH THE SCREEN SHALL NOT EXCEED 1.0 FEET.

1 SECTION  
C0551 16" DIW OUTLET PIPE  
N.T.S.

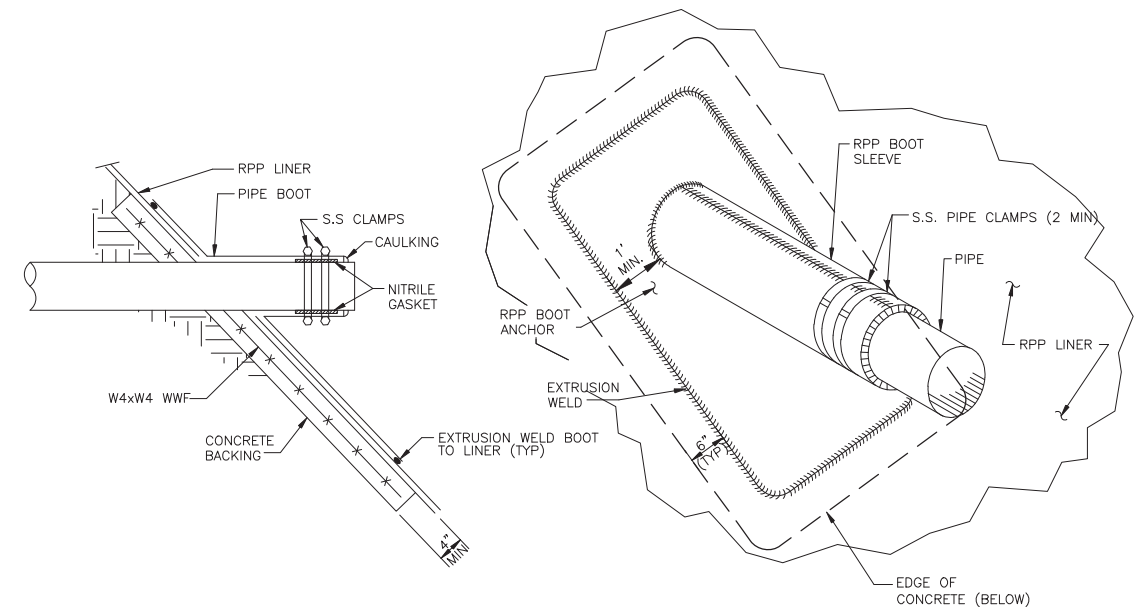

C SECTION  
C0551 PVC AND STAINLESS STEEL PIPE PENETRATION DETAIL  
N.T.S.

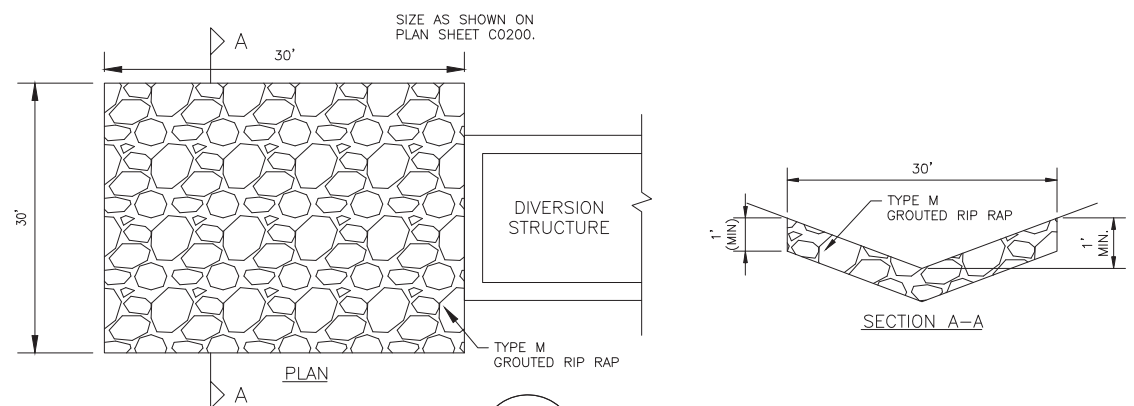

G SECTION  
C0551 RIP RAP DETAIL  
N.T.S.



| ISSUE RECORD | NO. | BY  | PURPOSE | DATE   | CKD |
|--------------|-----|-----|---------|--------|-----|
|              | 1   | JBW | IFC     | 21NO17 |     |

SCALE

DATE

APRIL 3, 2017

DRAWN BY:

APA

CHECKED BY:

JBW

FAA AIP NO.

WORK BREAKDOWN NO.

DESIGN CONTRACT NO.

201418360

CONST. CONTRACT NO.

201418360 TASK 5

VOLUME NO.

1

SHEET TITLE

CIVIL

DETAILS

SHEET NO.

C0552

18 OF 61

CADD FILE NO.

\_201418360-T5-11CDET-503-POND - 0055

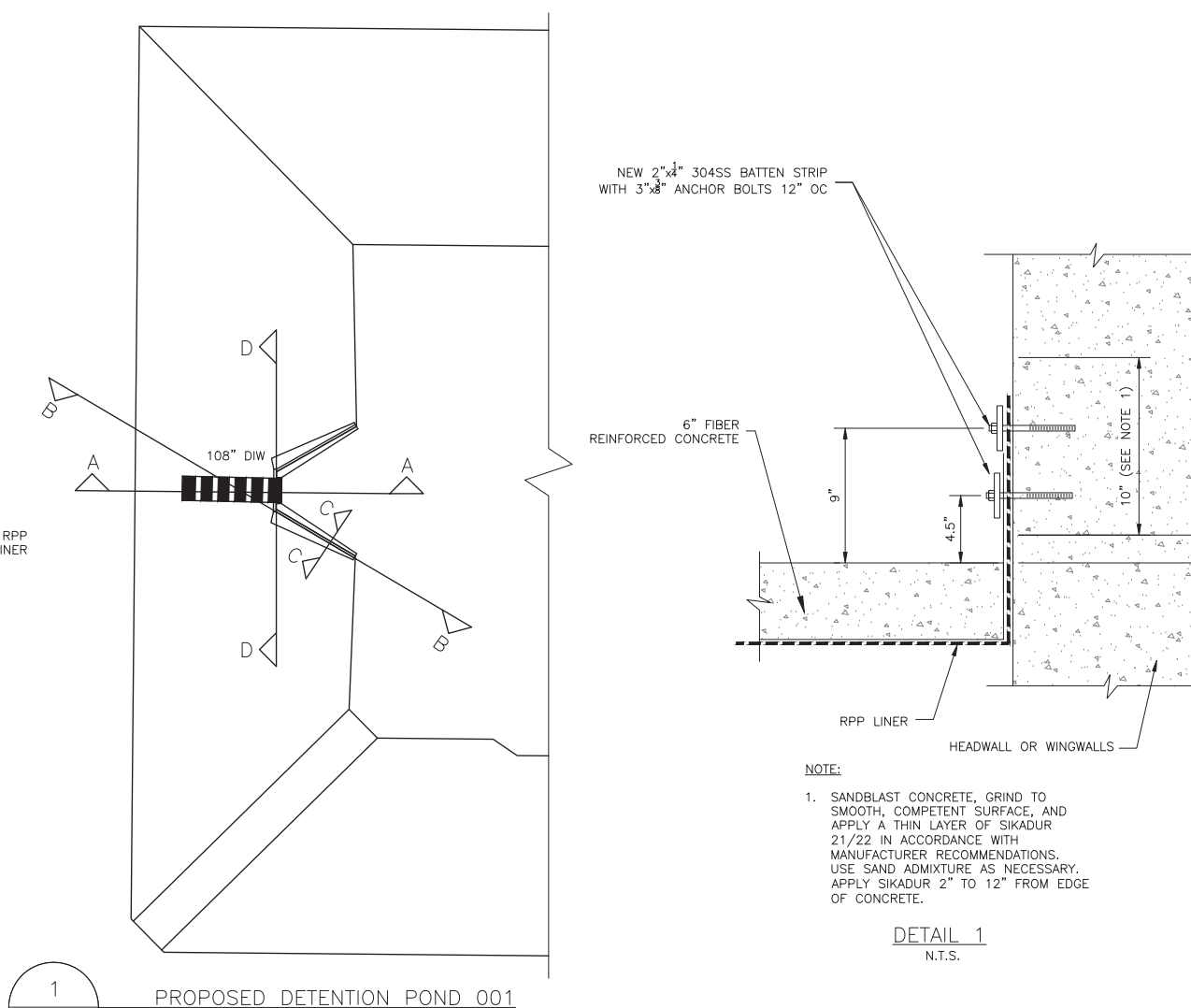
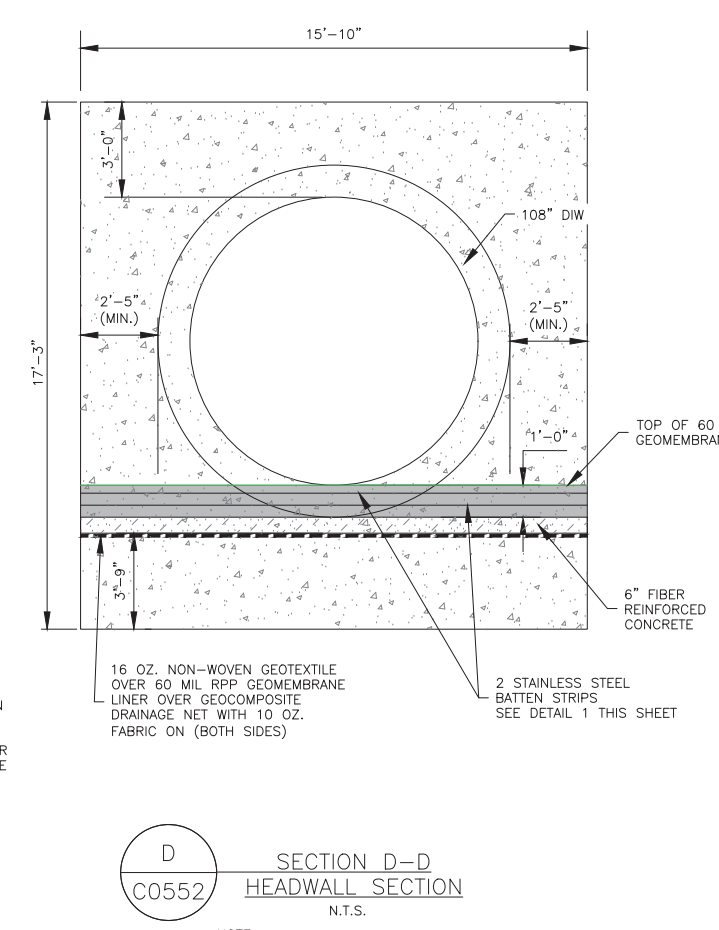
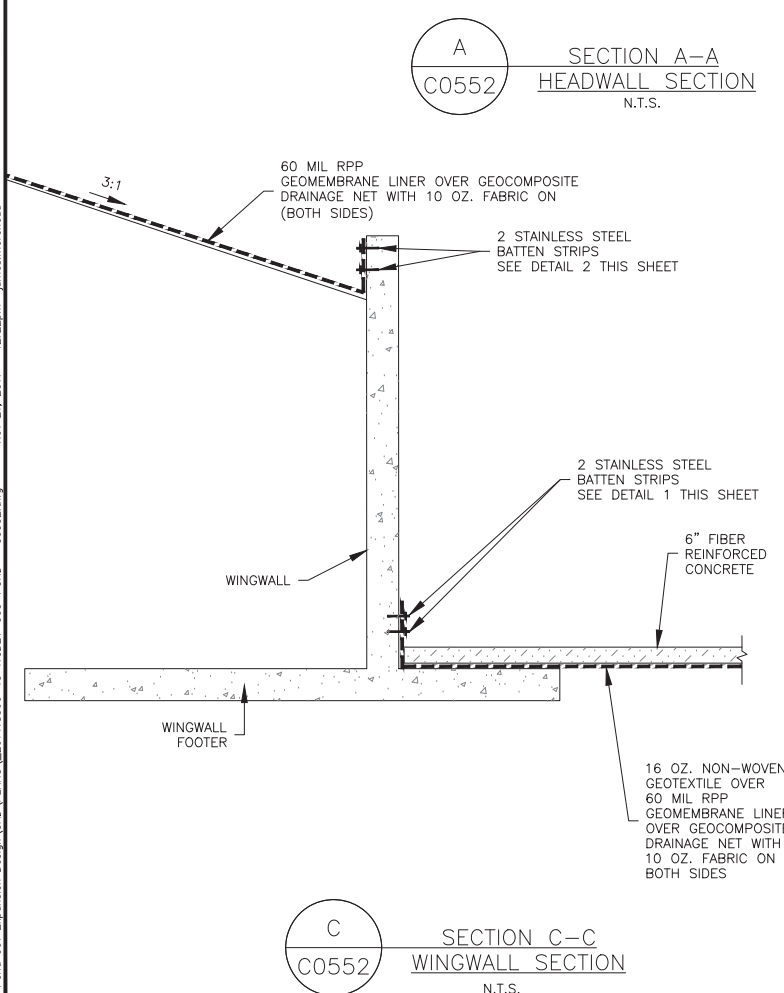
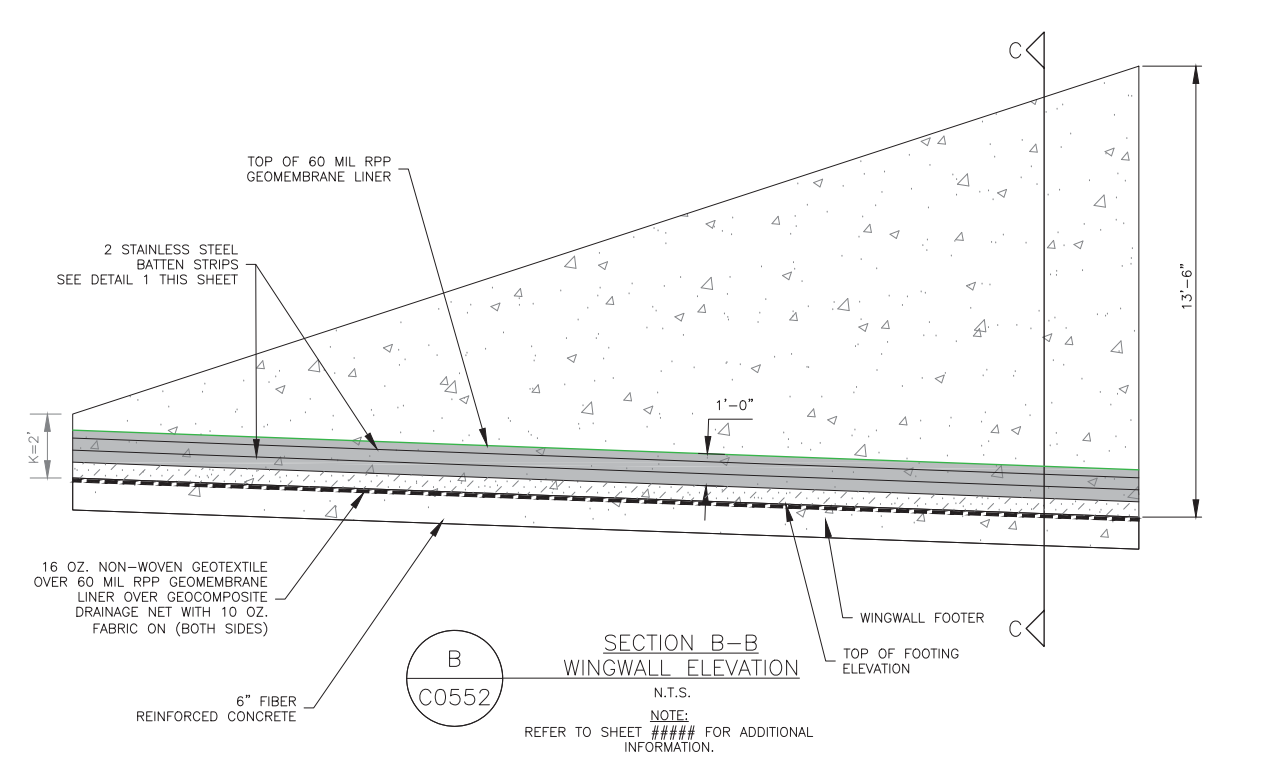
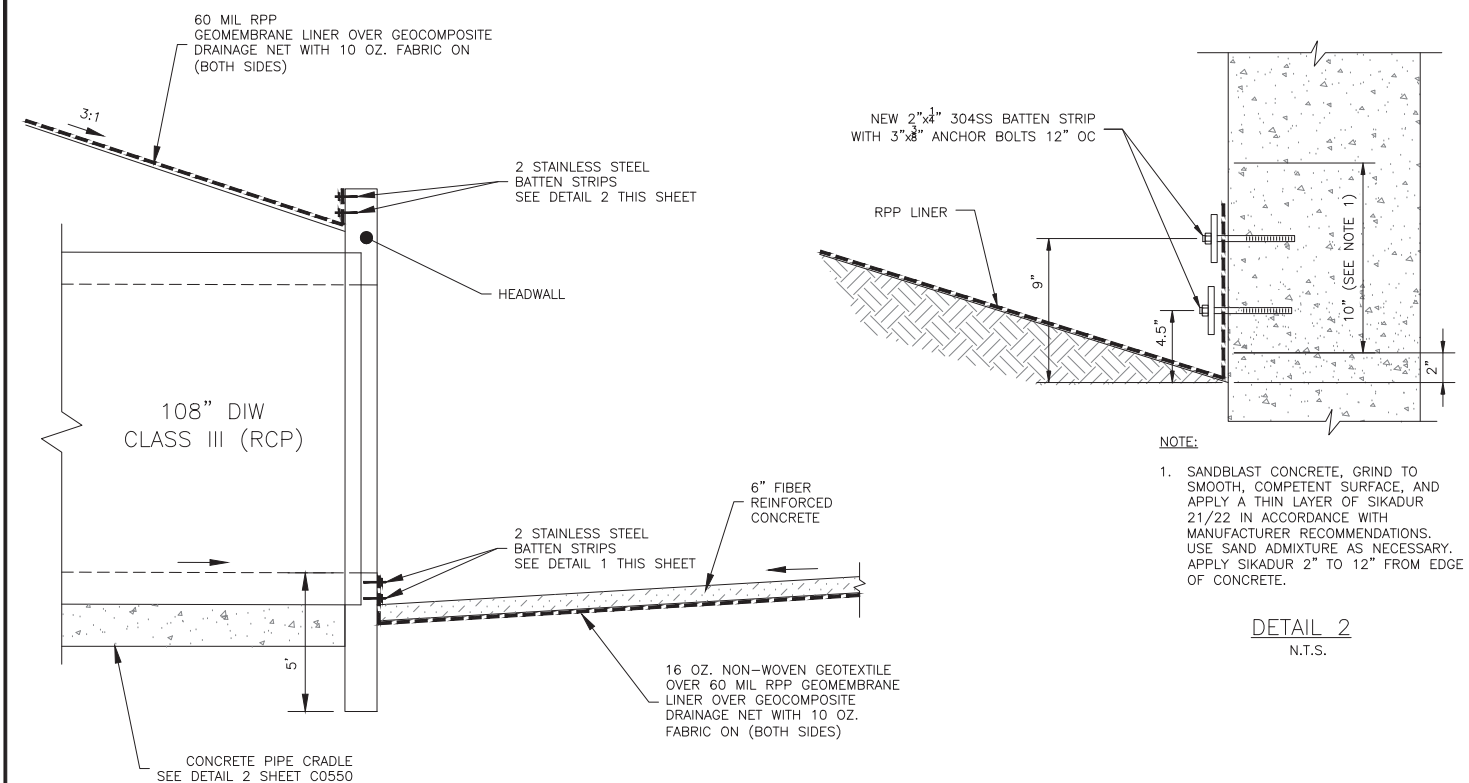

L:\014\201418360 DIW Pond 001 Expansion Design\CAD\PLANS\201418360-T5-11CDET-503-POND - C0552.dwg Nov 21, 2017 - 12:22pm james.morehead



| ISSUE RECORD | NO. | BY  | PURPOSE | DATE   | CKD |
|--------------|-----|-----|---------|--------|-----|
|              | 1   | JBW | IFC     | 21NO17 |     |

SCALE

DATE

APRIL 3, 2017

DRAWN BY: APA

CHECKED BY: JBW

FAA AIP NO:

WORK BREAKDOWN NO:

DESIGN CONTRACT NO.

201418360

CONST. CONTRACT NO.

201418360 TASK 5

VOLUME NO.

1

SHEET TITLE

CIVIL

DETAILS

SHEET NO.

C0553

19 OF 61

CADD FILE NO.

\_201418360-T5-11CDET-504-POND-C0553

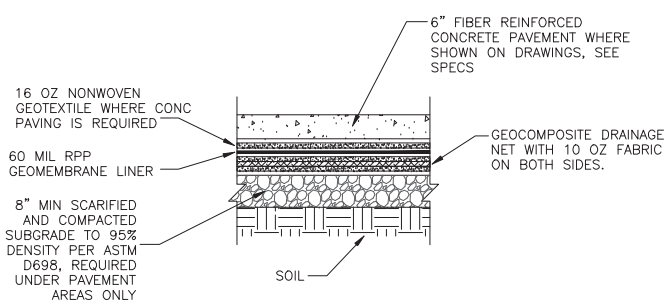

NOTE:  
SOIL UNDER RPP LINER AND GEOCOMPOSITE DRAINAGE NET SHALL BE GRADED SMOOTH AND SHALL BE FREE FROM ROCKS, VEGETATION, AND ALL DELTERIOUS MATERIAL. ALL LOOSE SOIL SHALL BE WATERED AND COMPACTED TO PROVIDE A SMOOTH, TIGHT SURFACE.

A REINFORCED POLYPROPYLENE LINER WITH GEOCOMPOSITE DRAINAGE NET DETAIL  
C0200 N.T.S.

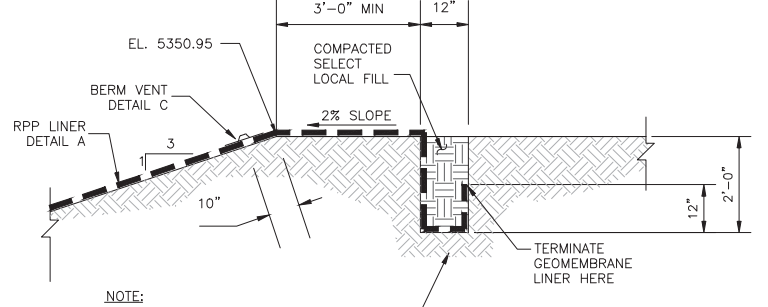

NOTE:  
ELEVATIONS SHOWN ON SHEET C0200 REPRESENT THE TOP OF RPP LINER.

B ANCHOR TRENCH DETAIL  
C0200 N.T.S.

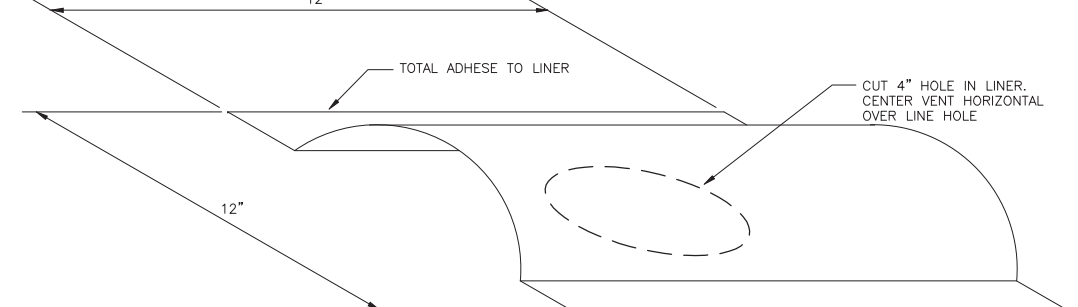

NOTE:  
INSTALL LINER VENTS AT A SPACING EQUAL TO 50 FEET ON CENTER.

C LINER VENTS DETAIL  
C0553 N.T.S.

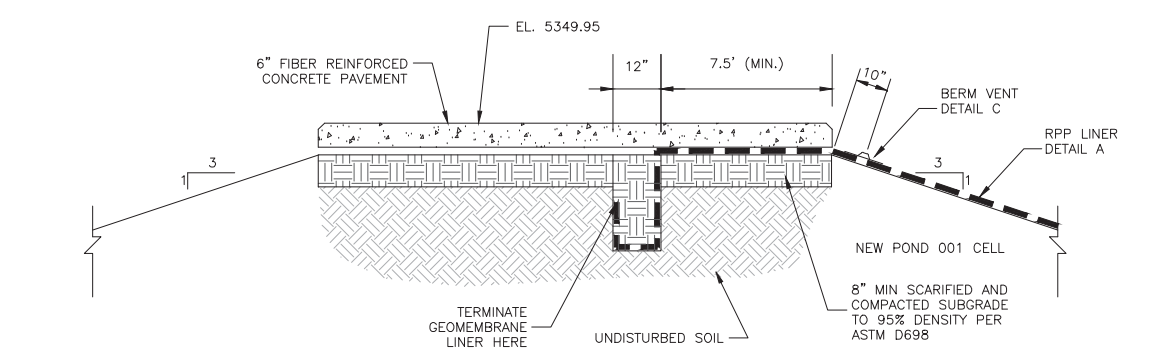

D CONCRETE OVERFLOW WEIR DETAIL  
C0200 N.T.S.

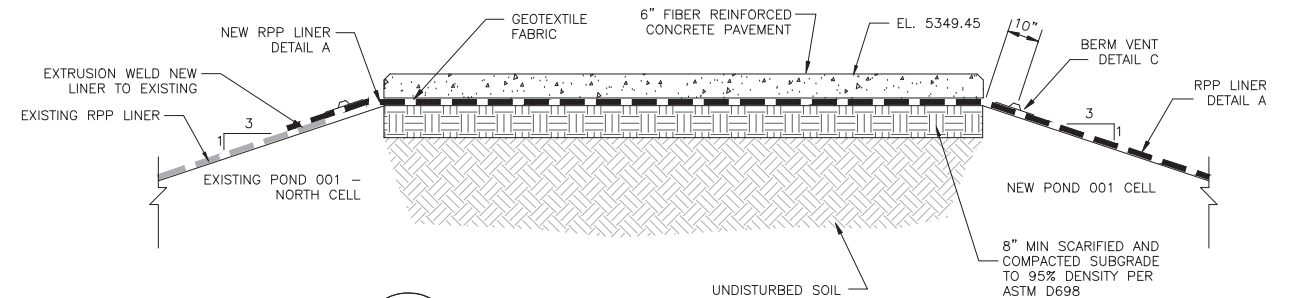

E CONCRETE OVERFLOW WEIR DETAIL  
C0200 N.T.S.

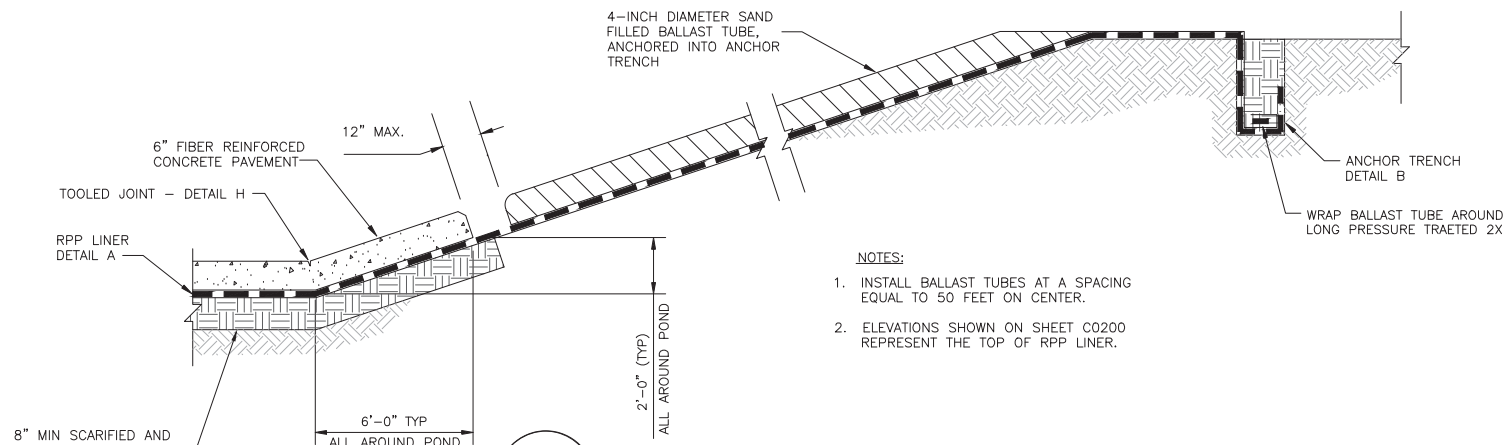

NOTES:  
1. INSTALL BALLAST TUBES AT A SPACING EQUAL TO 50 FEET ON CENTER.  
2. ELEVATIONS SHOWN ON SHEET C0200 REPRESENT THE TOP OF RPP LINER.

G BALLAST TUBE AND BASE PAVEMENT DETAIL  
C0200-C0300 N.T.S.

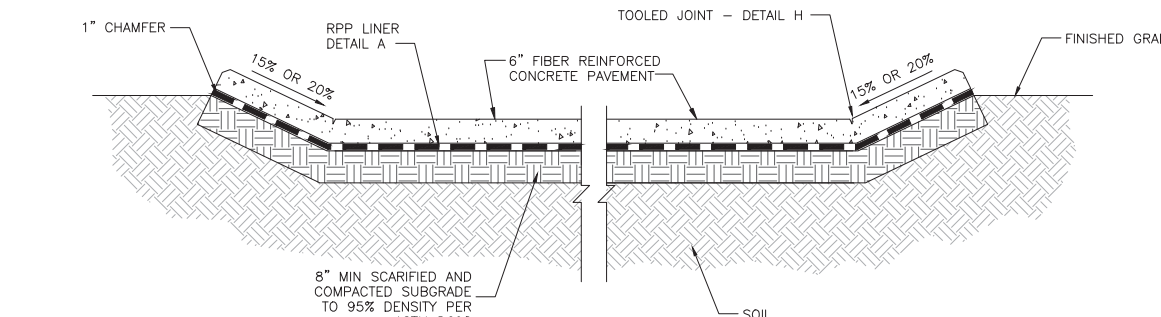

F CONCRETE OVERFLOW WEIR DETAIL  
C0200 N.T.S.

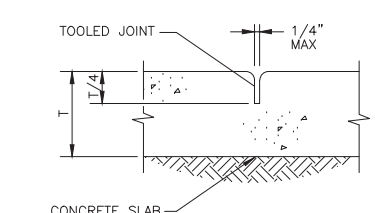

NOTE:  
REFER TO CONCRETE SPECIFICATIONS FOR CONCRETE PAVEMENT MIX DESIGN.

H TOOLED CONTROL JOINT DETAIL  
C0300 N.T.S.

L:\014\201418360 DWG Pond 001 Expansion Design\CAD\PLANS\201418360-T5-11CDET-504-POND-C0553.dwg Nov 21, 2017 12:25pm james.morehead







**NOTES:**

- CONNECT DUCTILE IRON PIPE TO VALVES AND TEES USING FLANGE ADAPTER, VICTAULIC STYLE 341, OR APPROVED EQUAL.
- ALL PIPE JOINTS SHALL BE FULLY RESTRAINED TYPE.
- ALL BURIED DUCTILE IRON PIPE SHALL BE POLYETHYLENE WRAPPED. REFER TO SPECIFICATION D-701 FOR MORE INFORMATION.
- ALL PIPING INSIDE NEW VALVE MANHOLES SHALL BE DUCTILE IRON. DUCTILE IRON PIPE SHALL EXTEND A MINIMUM OF 5 FEET BEYOND EXTERIOR WALL OF VALVE MANHOLES BEFORE TRANSITIONING TO NEW OR EXISTING PVC PIPE.
- PROVIDE LADDER IN MANHOLES MH-2 & MH-3 PER CDOT STANDARDS, SEE SHEET C0657. DO NOT INSTALL A LADDER IN MANHOLES MH-1 & MH-7.

**PLUG VALVE REQUIREMENTS:**

PLUG VALVES SHALL BE OF THE OFFSET DISC TYPE, QUARTER-TURN, NON-LUBRICATED, SERVICEABLE (ABLE TO BE REPACKED) UNDER FULL LINE PRESSURE AND CAPABLE OF SEALING IN BOTH DIRECTIONS AT THE RATED PRESSURE. THE DISC SHALL BE COMPLETELY OUT OF THE FLOW PAT WHEN OPEN. PLUG VALVES SHALL BE BY DEZURIK OF SARTELL, MINNESOTA, OR APPROVED EQUAL.

- VALVES SHALL BE RATED AT MINIMUM 150 PSI WORKING PRESSURE.
  - ALL PLUG VALVES SHALL BE PERFORMANCE, LEAKAGE, AND HYDROSTATICALLY TESTED IN ACCORDANCE WITH AWWA C504.
  - THE PLUG VALVES SHALL MEET OR EXCEED ALL TESTING REQUIREMENT OF MSS-SP-108.
  - THE VALVES SHALL BE CERTIFIED BY THE MANUFACTURER AS PERMITTING ZERO LEAKAGE FOR A PERIOD OF AT LEAST 2 HOURS WITH MAXIMUM RATED WORKING PRESSURE APPLIED IN EITHER DIRECTION.
- VALVE BODIES SHALL BE OF DUCTILE IRON, ASTM A536 AND OF THE TOP ENTRY, BOLTED BONNET DESIGN, CAST WITH INTEGRAL FLANGES CONFORMING TO THE CONNECTING PIPING. ALL EXPOSED BOLTS, NUTS, AND WASHERS SHALL TYPE 316 STAINLESS STEEL.
- THE VALVE PLUG SHALL:
  - BE DUCTILE IRON, ASTM A536, GRADE 65-45-12.
  - BE REMOVABLE WITHOUT REMOVING THE VALVE FROM THE LINE.
  - HAVE AN INTEGRAL UPPER AND LOWER SHAFT WHICH SHALL HAVE SEALS ON THE UPPER AND LOWER JOURNALS TO PREVENT ENTRANCE OF SOLIDS INTO THE JOURNALS.
- SHAFT BEARINGS SHALL BE PERMANENTLY LUBRICATED, RIGIDLY BACKED PTFE, TYPE 316 STAINLESS STEEL OR BRONZE AT BOTH UPPER AND LOWER STEM JOURNALS. THE OPERATOR SHAFT SHALL HAVE EASILY REPLACEABLE SEALS, WHICH SHALL BE EXTERNALLY ADJUSTABLE AND REPACKABLE WITHOUT REMOVING THE BONNET FROM THE VALVE OR SHALL HAVE SELF-ADJUSTING PACKING.
- PLUG VALVES SHALL BE INSTALLED SO THAT THE DIRECTION OF FLOW THROUGH THE VALVE AND THE SHAFT ORIENTATION IS IN ACCORDANCE WITH THE MANUFACTURER'S RECOMMENDATIONS. UNLESS OTHERWISE NOTED, SHAFT SHALL BE HORIZONTAL, WITH PLUG OPENING UP.
- THE VALVE SEATING SURFACE SHALL PROVIDE FULL 360-DEGREE SEATING BY CONTACT OF A RESILIENT SEATING MATERIAL ON THE DISC MATING WITH WELDED-IN HIGH NICKEL CONTENT OVERLAY SEATING SURFACE IN THE BODY. PLUGS SHALL HAVE A FULL RESILIENT FACING OF A SEALING MATERIAL COVERING THE ENTIRE DISC.
- THE VALVE MANUFACTURER SHALL PROVIDE CERTIFICATION THAT ALL MATERIALS USED IN THE MANUFACTURE OF THE VALVES, INCLUDING GASKETS, O-RINGS, AND OTHER SEALING MATERIALS, ARE COMPATIBLE WITH THE CONTAMINATES LISTED IN NOTE 36, SHEET C0003.

**ISSUE RECORD**

| NO. | BY  | PURPOSE | DATE   | CKD |
|-----|-----|---------|--------|-----|
| 1   | JBW | IFC     | 21NO17 |     |
|     |     |         |        |     |
|     |     |         |        |     |
|     |     |         |        |     |
|     |     |         |        |     |
|     |     |         |        |     |
|     |     |         |        |     |
|     |     |         |        |     |
|     |     |         |        |     |

**SCALE**

DATE: APRIL 3, 2017

DRAWN BY: APA

CHECKED BY: JBW

FAA AIP NO:

WORK BREAKDOWN NO:

DESIGN CONTRACT NO: 201418360

CONST. CONTRACT NO: 201418360 TASK 5

VOLUME NO: 1

SHEET TITLE: CIVIL DETAILS

SHEET NO: C0555

21 OF 61

CADD FILE NO: \_201418360-T5-11CDET-506-POND - 0055

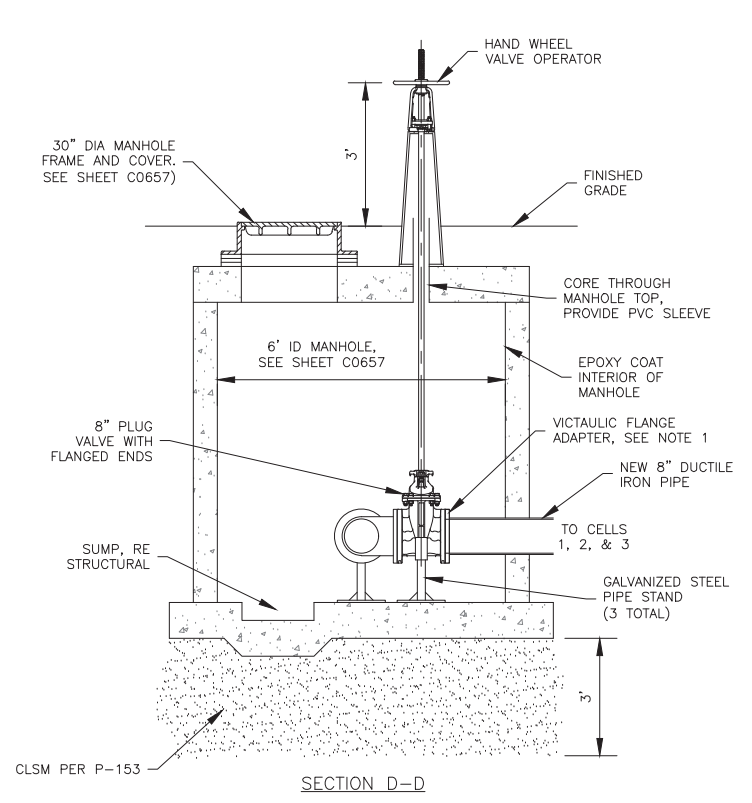

SECTION D-D

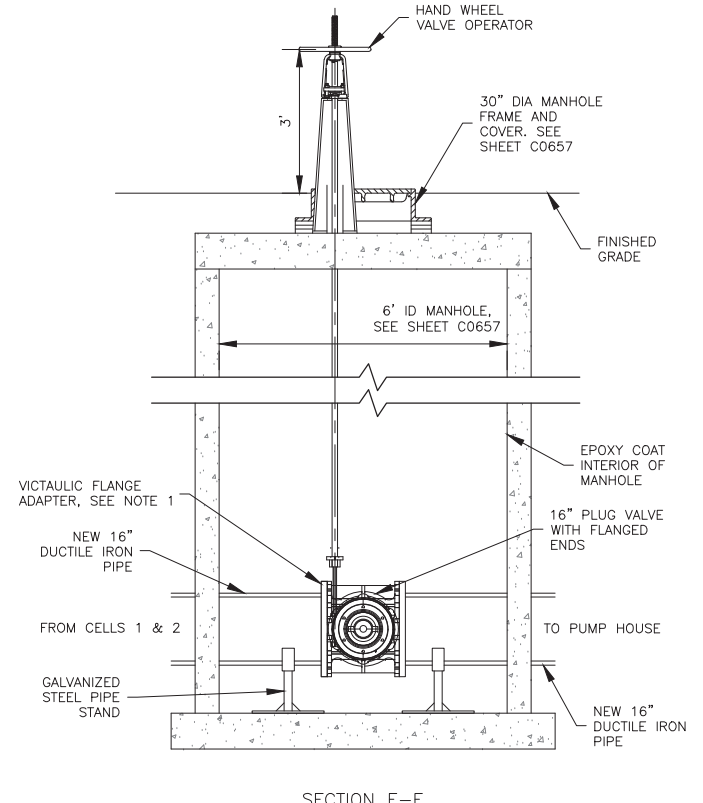

SECTION E-E

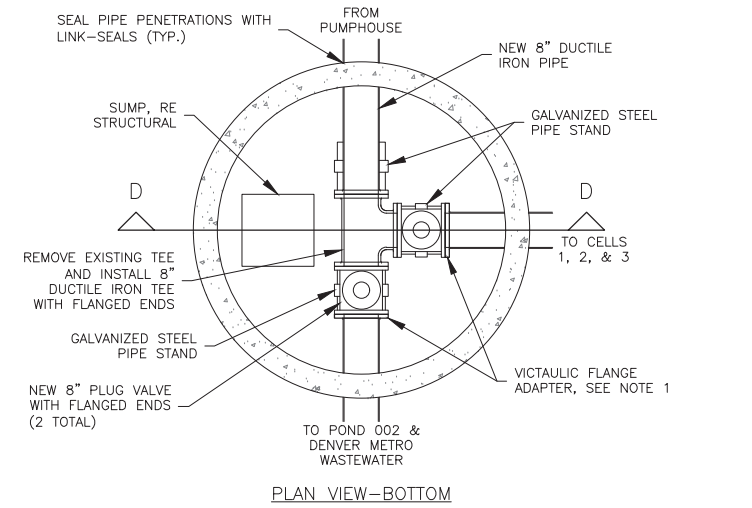

PLAN VIEW-BOTTOM

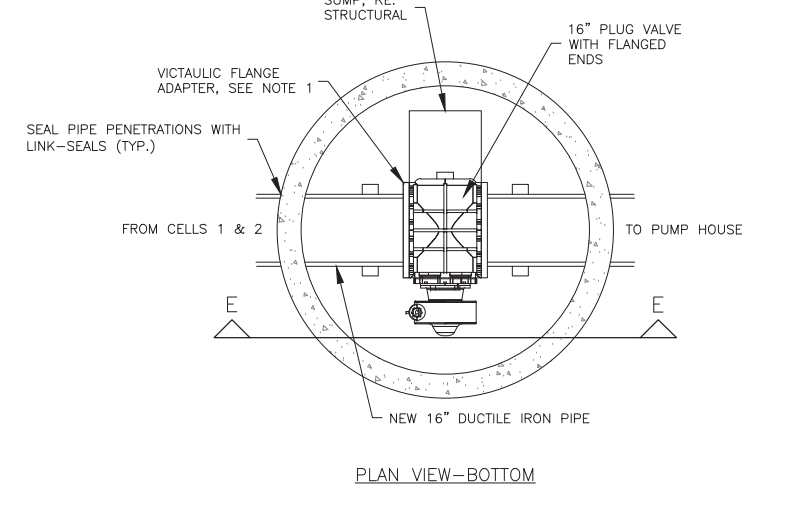

PLAN VIEW-BOTTOM

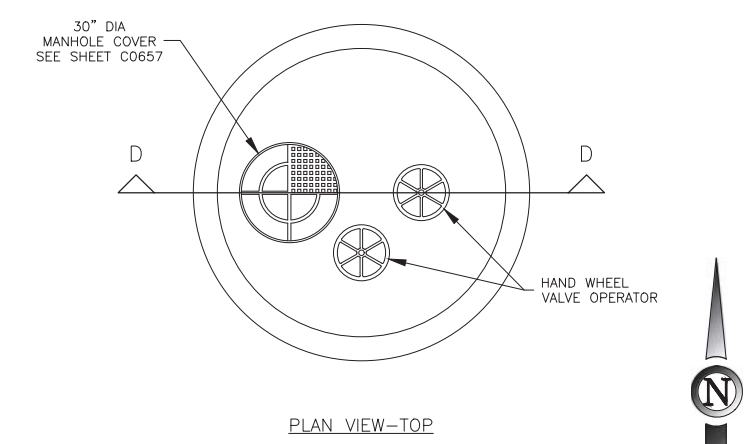

PLAN VIEW-TOP

1  
C0500  
MANHOLE MH-3  
N.T.S.

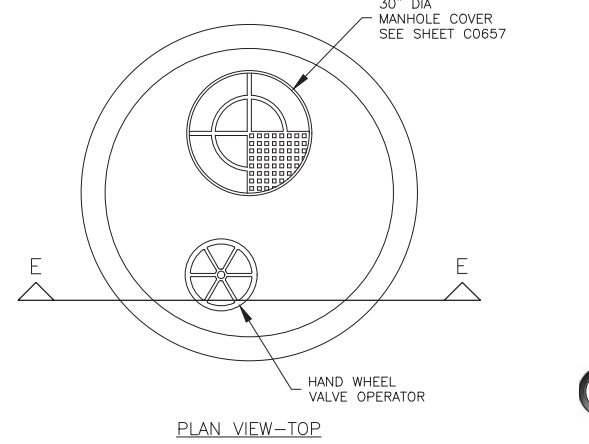

PLAN VIEW-TOP

2  
C0500  
MANHOLE MH-7  
N.T.S.

L:\DIA\201418360 DWG Pond 001 Expansion Design\CAD\PLANS\201418360-T5-11CDET-506-POND - 00555.dwg Nov 21, 2017 - 12:23pm James.morehead



**POND 001 EXPANSION**

ISSUE RECORD

| NO. | BY  | PURPOSE | DATE   | CKD |
|-----|-----|---------|--------|-----|
| 1   | JBW | IFC     | 21NO17 |     |
|     |     |         |        |     |
|     |     |         |        |     |
|     |     |         |        |     |
|     |     |         |        |     |
|     |     |         |        |     |
|     |     |         |        |     |
|     |     |         |        |     |
|     |     |         |        |     |

SCALE

DATE APRIL 3, 2017

DRAWN BY: APA

CHECKED BY: JBW

FAA AIP NO. \_\_\_\_\_

WORK BREAKDOWN NO. \_\_\_\_\_

DESIGN CONTRACT NO. 201418360

CONST. CONTRACT NO. 201418360 TASK 5

VOLUME NO. 1

SHEET TITLE

**DIW  
PLAN AND  
PROFILES**

SHEET NO. **C0600**

22 OF 61

CADD FILE NO. 201418360-T5-11CJPP-101-POND

PROFILE SCALE:  
VERTICAL 1" = 5'  
HORIZONTAL 1" = 50'

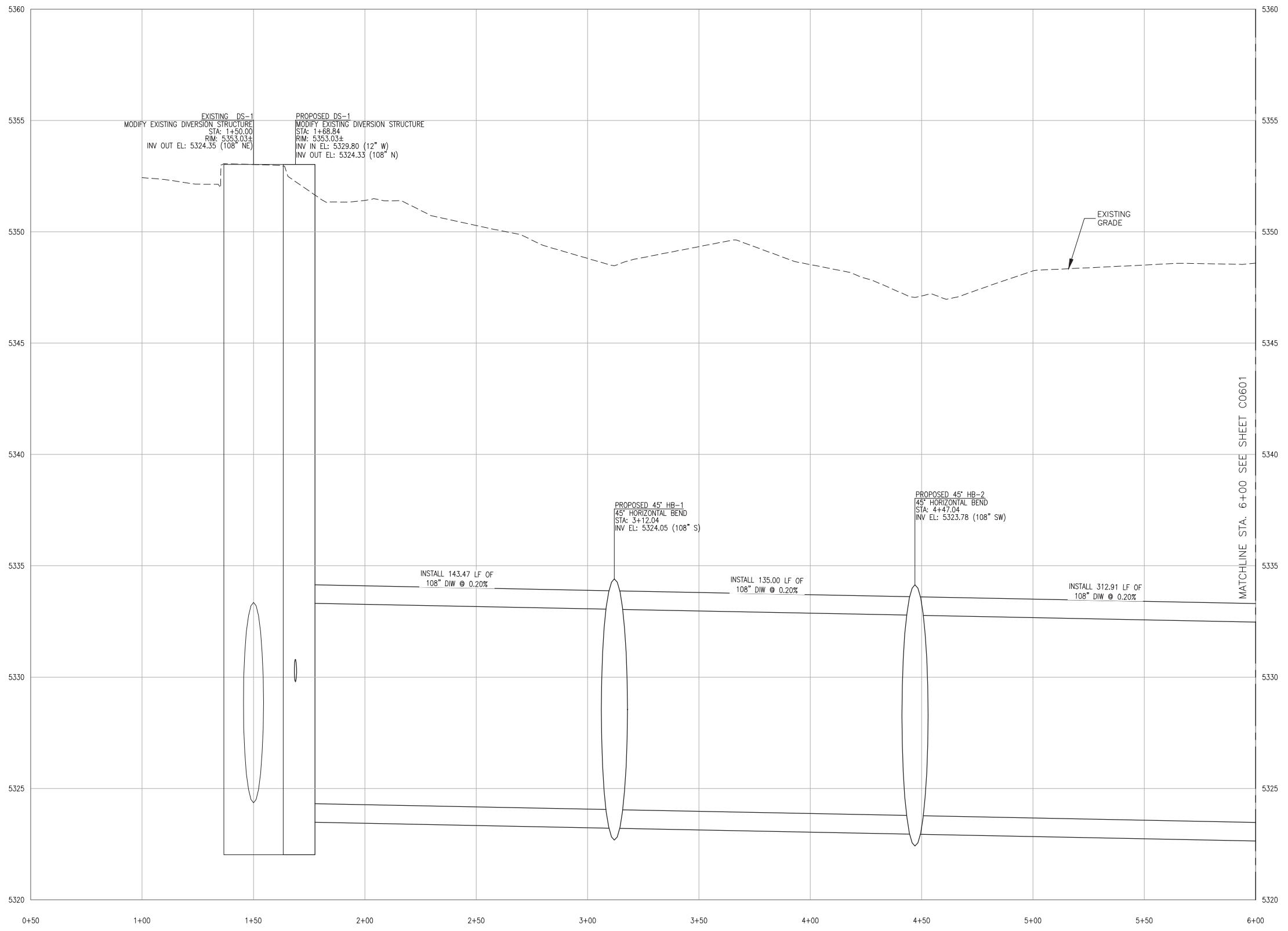

L:\DIA\201418360 DIW Pond 001 Expansion Design\CAD\PLANS\201418360-T5-11CJPP-101-POND.dwg Nov 21, 2017 - 12:25pm james.morehead



**POND 001 EXPANSION**

ISSUE RECORD

| NO. | BY  | PURPOSE | DATE   | CHKD |
|-----|-----|---------|--------|------|
| 1   | JBW | IFC     | 21NO17 |      |

SCALE

DATE APRIL 3, 2017

DRAWN BY: APA

CHECKED BY: JBW

FAA AIP NO. \_\_\_\_\_

WORK BREAKDOWN NO. \_\_\_\_\_

DESIGN CONTRACT NO. \_\_\_\_\_

CONST. CONTRACT NO. 201418360

201418360 TASK 5

VOLUME NO. \_\_\_\_\_

SHEET TITLE 1

**DIW**

**PLAN AND**

**PROFILES**

SHEET NO. \_\_\_\_\_

**C0601**

23 OF 61

CADD FILE NO. \_\_\_\_\_

\_\_\_\_\_  
\_201418360-T5-11CJPP-102-POND

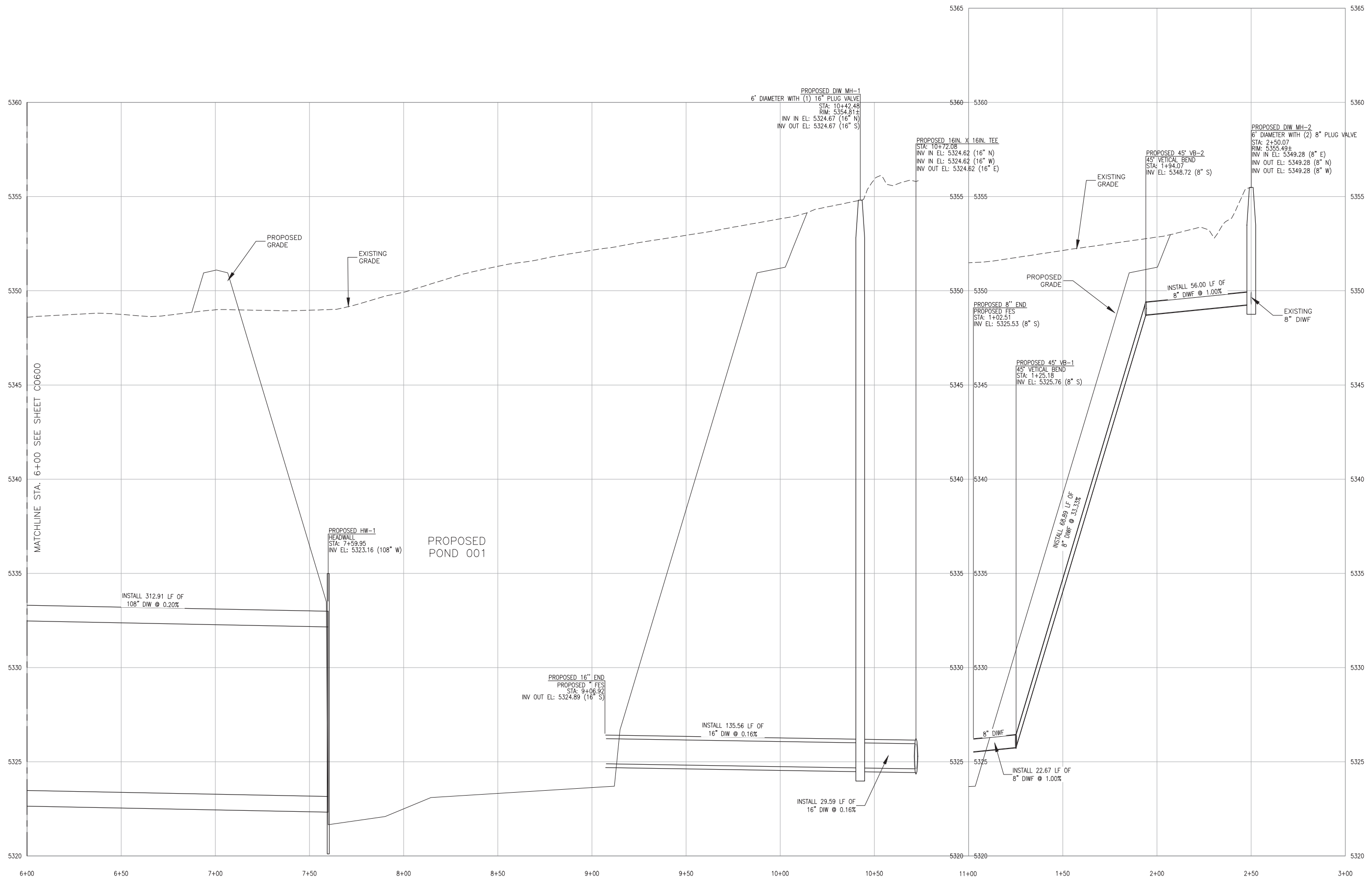

PROFILE SCALE:  
VERTICAL 1" = 5'  
HORIZONTAL 1" = 50'

L:\DIA\201418360 DIW Pond 001 Expansion Design\CAD\PLANS\201418360-T5-11CJPP-102-POND.dwg Nov 21, 2017 - 12:26pm james.morinhead



POND 001 EXPANSION

ISSUE RECORD

| NO. | BY  | PURPOSE | DATE   | CKD |
|-----|-----|---------|--------|-----|
| 1   | JBW | IFC     | 21NO17 |     |
|     |     |         |        |     |
|     |     |         |        |     |
|     |     |         |        |     |
|     |     |         |        |     |
|     |     |         |        |     |
|     |     |         |        |     |
|     |     |         |        |     |
|     |     |         |        |     |

SCALE

DATE

APRIL 3, 2017

DRAWN BY:

APA

CHECKED BY:

JBW

FAA AIP NO:

WORK BREAKDOWN NO:

DESIGN CONTRACT NO:

201418360

CONST. CONTRACT NO:

201418360 TASK 5

VOLUME NO:

1

SHEET TITLE

DIW

PLAN AND  
PROFILE

SHEET NO.

C0602

24 OF 61

CADD FILE NO.

\_201418360-T5-11CJPP-103-POND

PROFILE SCALE:  
VERTICAL 1" = 5'  
HORIZONTAL 1" = 50'

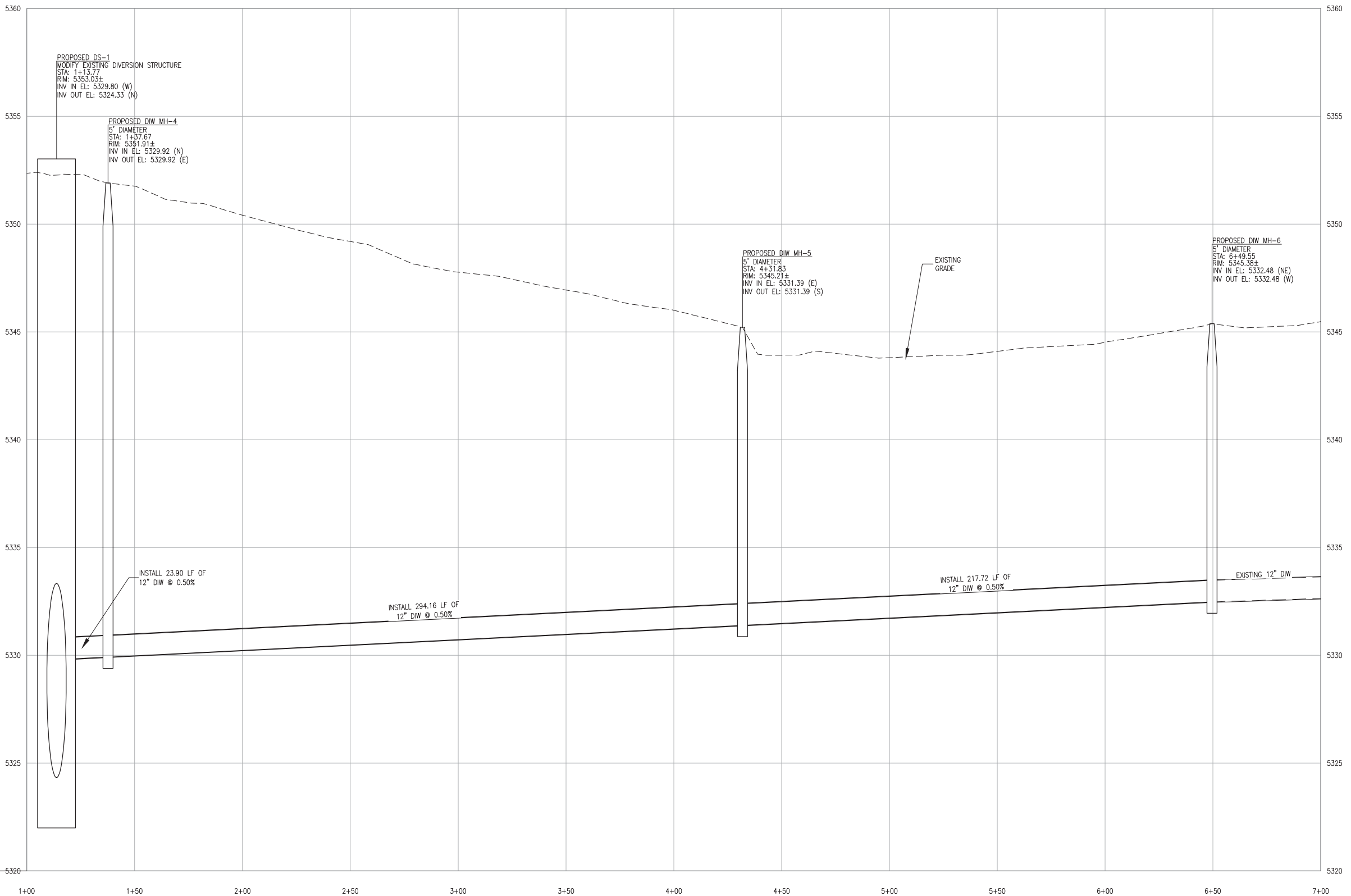

L:\DIA\201418360 DIW Pond 001 Expansion Design\CAD\PLANS\201418360-T5-11CJPP-103-POND.dwg Nov 21, 2017 - 12:26pm james.morinhead





| NO. | BY  | DATE | DESCRIPTION OF REVISIONS |
|-----|-----|------|--------------------------|
| 1   | JBW | IFC  | 21NO17                   |

SCALE

DATE APRIL 3, 2017

DRAWN BY: APA

CHECKED BY: JBW

FAA AIP NO.

WORK BREAKDOWN NO.

DESIGN CONTRACT NO. 201418360

CONST. CONTRACT NO. 201418360 TASK 5

VOLUME NO. 1

SHEET TITLE STANDARD DETAILS FOR MANHOLES

SHEET NO. C0651

26 OF 61

CADD FILE NO. \_201418360-T5-1CUTP-502-POND

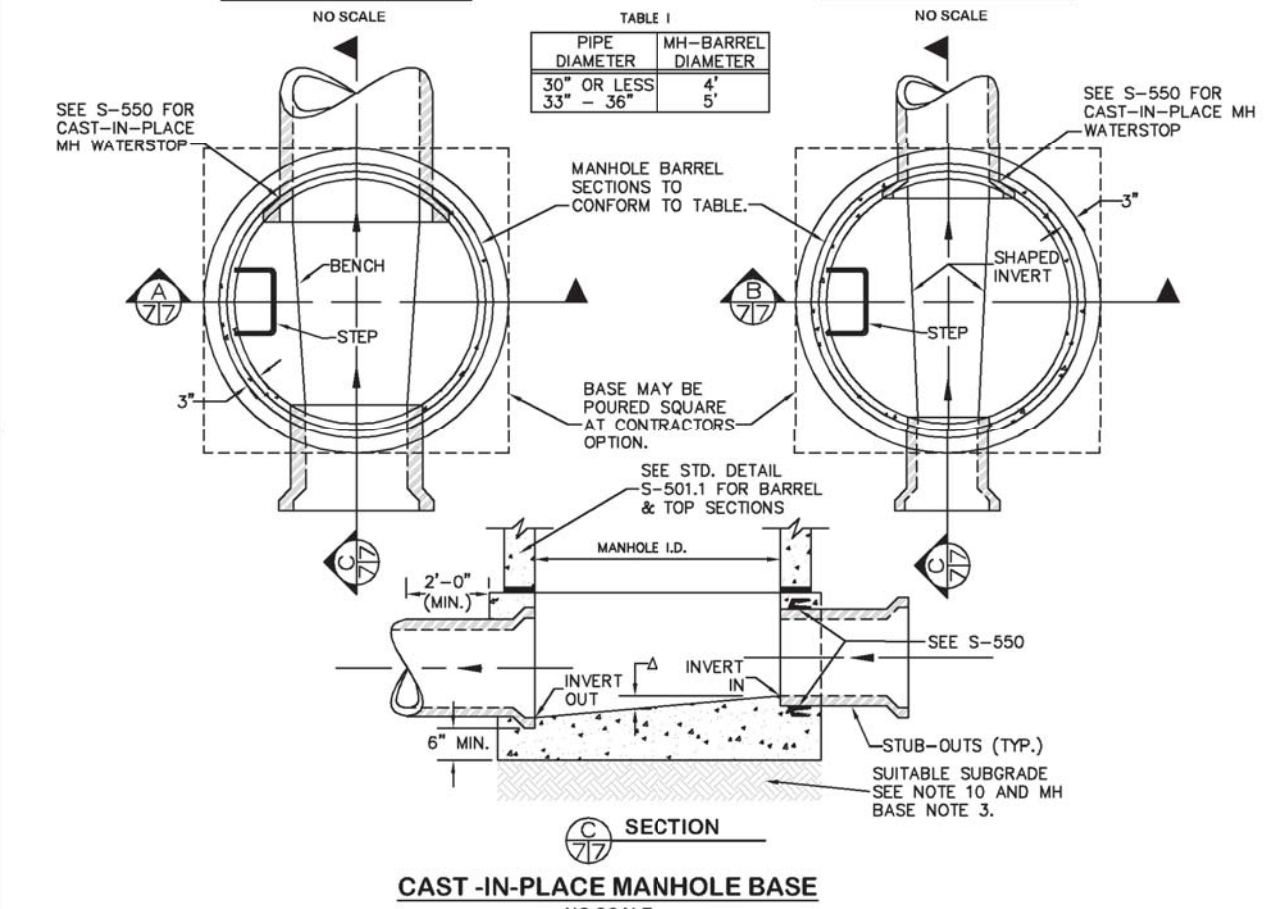
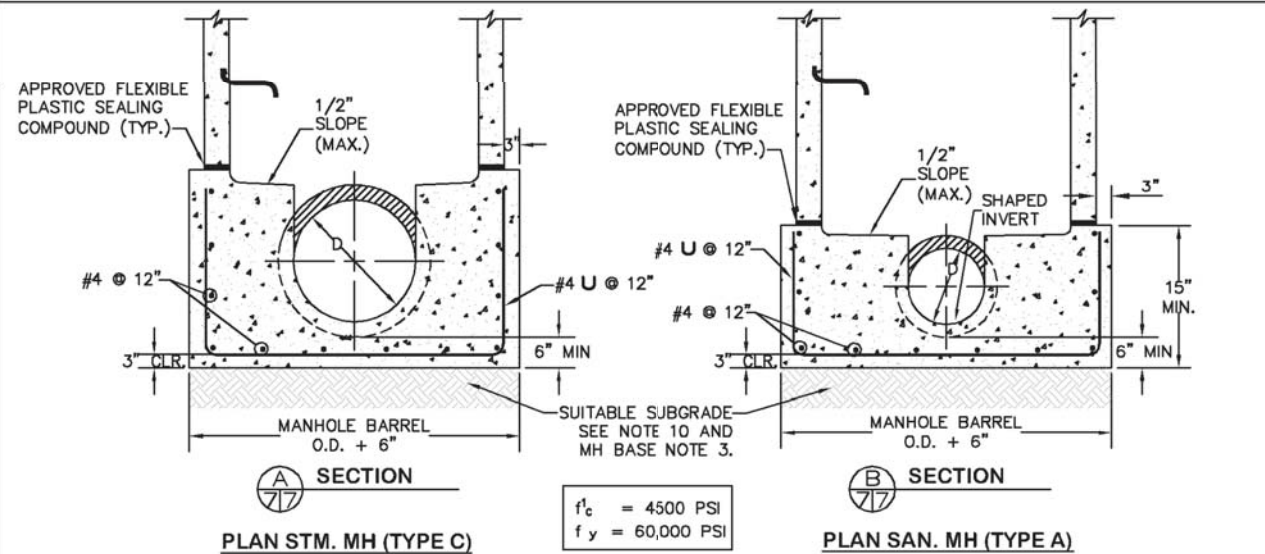

- NOTES:
- MANHOLE BARREL MINIMUM DIAMETER SHALL CONFORM TO TABLE I.
  - GROUTED FLOW CHANNELS AND INVERTS MAY BE FORMED BY SHAPING WITH LEAN CONCRETE ( $f'_c=2000$  PSI MIN.).
  - MANHOLE STEPS SHALL CONFORM TO DIVISION SPECIFICATIONS AND WMD STANDARD DETAILS S-750.
  - ALL DEAD END MANHOLES SHALL BE STUBBED THRU AT 0.40% MINIMUM SLOPE.
  - STUB-OUTS SHALL EXTEND 2'-0" MIN. PAST MANHOLE O.D. AND BE FACTORY PLUGGED.
  - REINFORCING IS REQUIRED FOR ALL MANHOLE BASES.
  - SLOPE MANHOLE BENCH 1/2" MAXIMUM TOWARD FLOW CHANNEL.
  - INVERT DROP THRU MANHOLE. FOR SANITARY SEWERS, IF  $\geq 18"$ , AN OUTSIDE DROP MANHOLE IS REQUIRED (S-530).
  - SHIPLAP JOINTS ON MANHOLE BARREL RISER SHALL CONFORM TO DIVISION STANDARDS AND SPECIFICATIONS (S-401).
  - CAST IN PLACE MANHOLE BASES SHALL BE PLACED ON SUITABLE SUBGRADE MATERIAL. AT THE DIRECTION OF THE ENGINEER THE SUBGRADE SHALL BE OVEREXCAVATED AND STABILIZED WITH AN ACCEPTABLE GRANULAR MATERIAL, COMPACTED TO 95% OF MAXIMUM DRY DENSITY IN ACCORDANCE WITH AASHTO T-180.
  - ALL PIPE OPENINGS SHALL BE CONSTRUCTED WITH AN APPROVED FLEXIBLE WEDGE-TYPE GASKET CONFORMING TO ASTM C-443 WHICH SHALL BE CAPABLE OF PROVIDING A WATER TIGHT JOINT WITH ZERO LEAKAGE AROUND THE INSTALLED PIPE. CONCRETE TO CONCRETE DONE WITHOUT WATER STOP GASKET FOR STORM SEWER WILL BE AT THE DISCRETION OF THE CITY ENGINEER (SEE S-550). AN APPROVED FLEXIBLE BOOT TYPE SLEEVE MAY ALSO BE USED FOR PRECAST INSTALLATIONS.
  - PRECAST BARREL SECTIONS, CONES, RISERS, ETC. SHALL CONFORM TO ASTM C-478, LATEST REVISION.

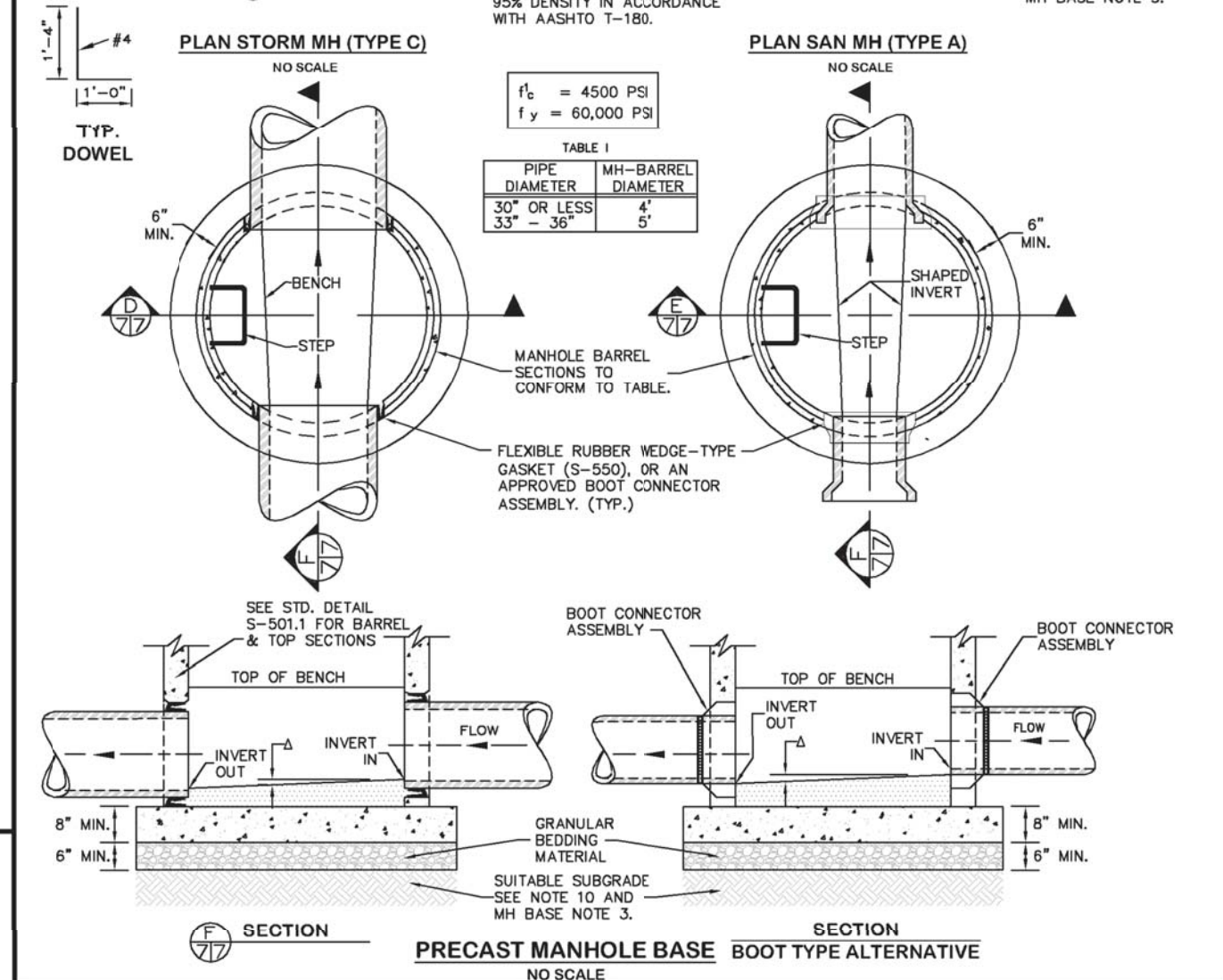
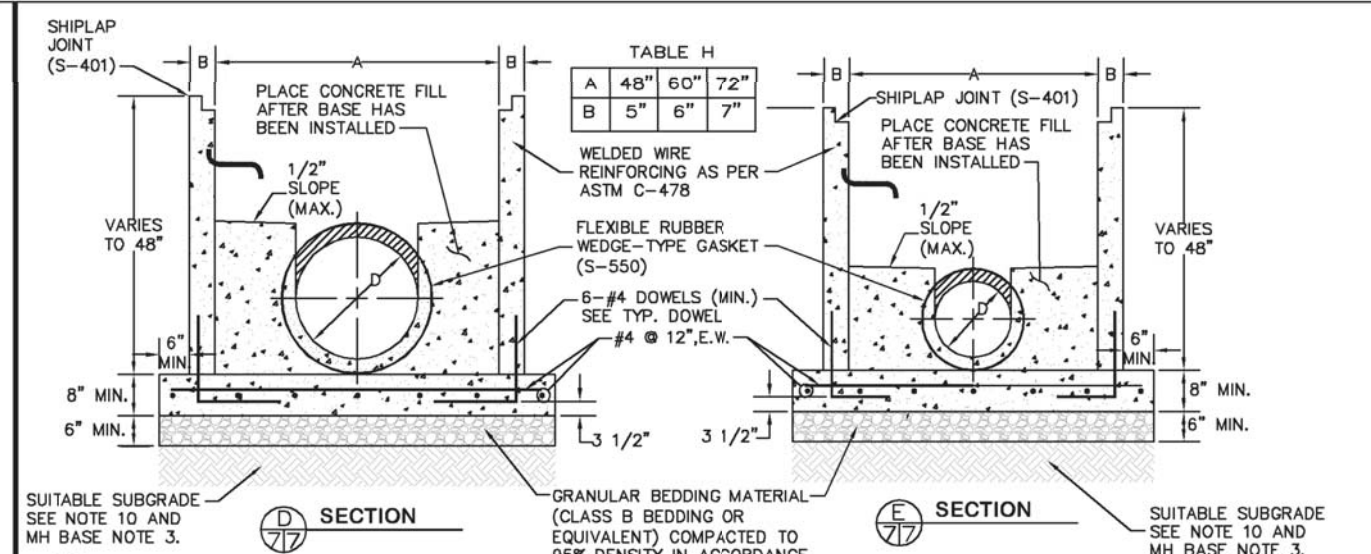

- PRECAST MANHOLE BASE NOTES:
- THE BASE SLAB SHALL BE POURED MONOLITHICALLY WITH BOTTOM RISER SECTION.
  - PRECAST MANHOLE BASES SHALL FIT THE CONDITIONS AND LOCATIONS FOR WHICH THEY ARE INTENDED WITHOUT ANY FIELD MODIFICATIONS. ANY MANHOLE BASE WHICH REQUIRES FIELD CUTTING OR MODIFICATION IN ORDER TO FIT THE LOCATIONS INTENDED SHALL BE REJECTED BY THE CITY AND REMOVED AND REPLACED BY THE CONTRACTOR AT NO COST TO THE CITY.
  - PRECAST MANHOLE BASES ARE TO BE BEDDED ON AN APPROVED GRANULAR BEDDING MATERIAL AS DETAILED ABOVE.

| NO. | BY  | DATE | DESCRIPTION OF REVISIONS |
|-----|-----|------|--------------------------|
| 1   | JBW | IFC  | 21NO17                   |

CITY AND COUNTY OF DENVER  
DEPARTMENT OF PUBLIC WORKS  
ENGINEERING DIVISION  
CAPITAL PROJECTS MANAGEMENT  
2000 W. 3RD AVE. DENVER, CO 80223  
TEL.: (303) 446-3617 FAX: (303) 446-3647

STANDARD DETAILS  
MANHOLE BASE CONSTRUCTION - TYPE A-C  
PAGE 1  
S-502

L:\014\201418360 DWG Pond 001 Expansion Design\CADD\PLANS\201418360-T5-1CUTP-502-POND.dwg Nov 21, 2017 - 12:26pm jmas.morehead











| ISSUE RECORD | NO. | BY  | PURPOSE | DATE   | CKD |
|--------------|-----|-----|---------|--------|-----|
| 1            | JBW | IFC |         | 21NO17 |     |

|                     |                  |
|---------------------|------------------|
| SCALE               |                  |
| DATE                | APRIL 3, 2017    |
| DRAWN BY:           | APA              |
| CHECKED BY:         | JBW              |
| FAA AIP NO.         |                  |
| WORK BREAKDOWN NO.  |                  |
| DESIGN CONTRACT NO. | 201418360        |
| CONST. CONTRACT NO. | 201418360 TASK 5 |
| VOLUME NO.          | 1                |

|             |                                     |
|-------------|-------------------------------------|
| SHEET TITLE | STANDARD<br>DETAILS FOR<br>MANHOLES |
|-------------|-------------------------------------|

|               |                              |
|---------------|------------------------------|
| SHEET NO.     | C0657<br>30 OF 61            |
| CADD FILE NO. | _201418360-T5-1CUTP-508-POND |

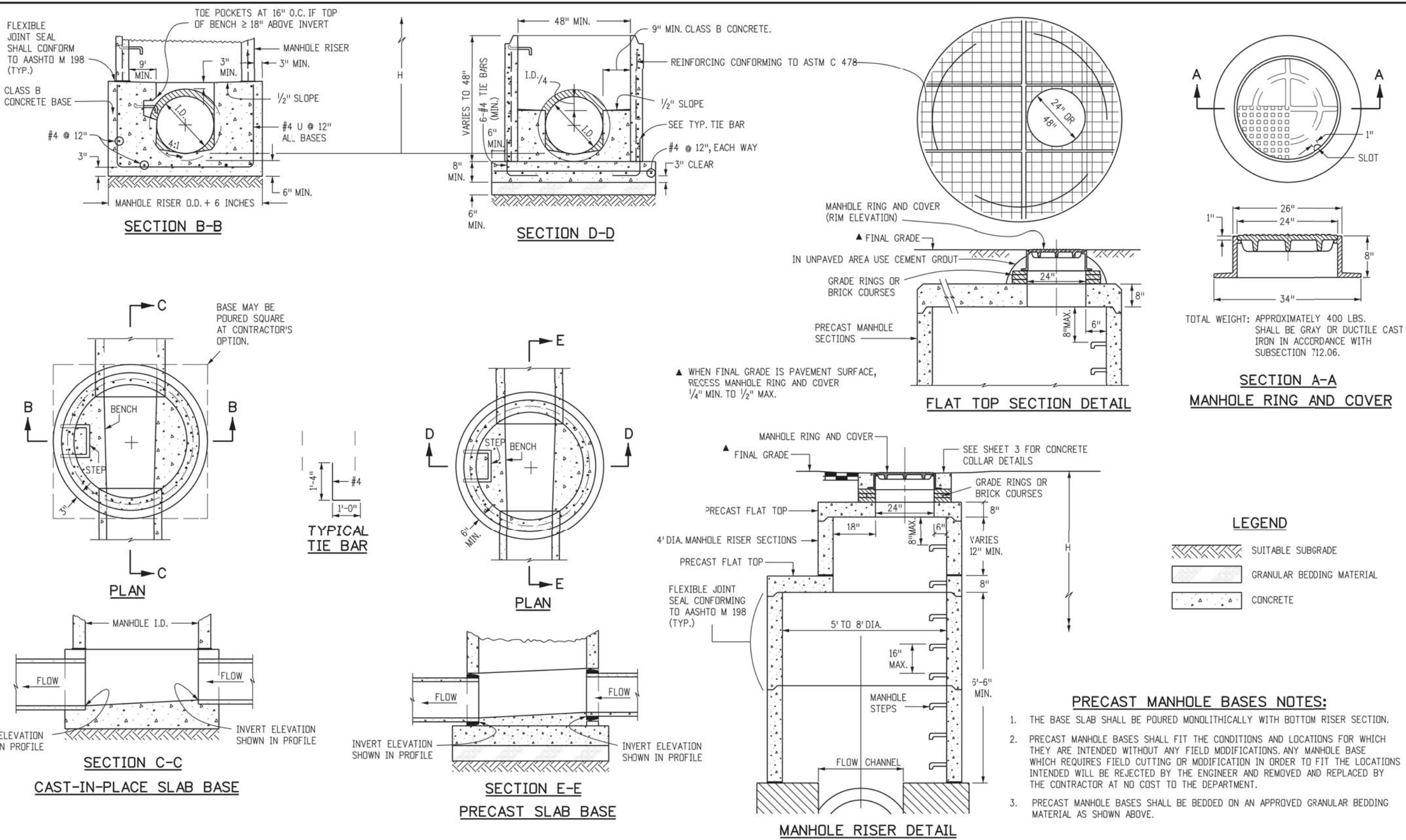

**Computer File Information**

|  |                                    |
|--|------------------------------------|
| Creation Date: 07/04/12                                | Initials: DD                       |
| Last Modification Date: 07/04/12                       | Initials: LTA                      |
| Full Path: www.coloradodot.info/business/designsupport |                                    |
| Drawing File Name: M06040200203.dgn                    |                                    |
| CAD Ver.: MicroStation V8                              | Scale: Not to Scale Units: English |

**Sheet Revisions**

| Date: | Comments |
|-------|----------|
| (R-X) |          |
| (R-X) |          |
| (R-X) |          |
| (R-X) |          |

**Colorado Department of Transportation**

4201 East Arkansas Avenue  
Denver, Colorado 80222  
Phone: (303) 757-9083  
Fax: (303) 757-9820

**Project Development Branch DD/LTA**

**STANDARD PLAN NO.**

**MANHOLES**

Issued By: Project Development Branch July 4, 2012

**STANDARD PLAN NO.**

**M-604-20**

Sheet No. 2 of 3

L:\DIA\201418360 DWP Pond 001 Expansion Design\CAD\PLANS\201418360-T5-1CUTP-508-POND.dwg Nov 21, 2017 - 12:27pm jmas.morehead



| ISSUE RECORD | NO. | BY  | PURPOSE | DATE   | CHKD |
|--------------|-----|-----|---------|--------|------|
| 1            | JBW | IFC |         | 21NO17 |      |

SCALE

DATE APRIL 3, 2017

DRAWN BY: APA

CHECKED BY: JBW

FAA AIP NO.

WORK BREAKDOWN NO.

DESIGN CONTRACT NO. 201418360

CONST. CONTRACT NO. 201418360 TASK 5

VOLUME NO. 1

SHEET TITLE  
STANDARD  
DETAILS FOR  
MANHOLES

SHEET NO. C0658

31 OF 61

CADD FILE NO. 201418360-T5-1CUTP-509-POND

**T-BASE MANHOLES NOTES**

1. THE T-BASE SECTION SHALL BE SHOP-FABRICATED FOR DELIVERY TO THE CONSTRUCTION SITE AS A COMPLETE UNIT.
2. THESE DETAILS SHOW ONLY THE CONCEPTUAL AND STANDARD DIMENSIONAL REQUIREMENTS FOR TYPE T-BASE MANHOLES. THE CONTRACTOR SHALL FURNISH DETAILED SHOP DRAWINGS FOR APPROVAL PRIOR TO FABRICATION. THE DETAILS SHOWN HEREIN APPLY ONLY TO 48 IN. AND GREATER DIAMETER PIPES.
3. EXCEPT FOR CLASS OF PIPE, SPECIFICATIONS FOR THE MANHOLE SHALL BE THE SAME AS THOSE REQUIRED FOR THE ADJOINING PIPE.
4. THE T-BASE SECTION SHALL MAINTAIN ITS INTERNAL SHAPE AND FLOW AREA. GROUTING OR FILLING SHALL BE APPLIED SO AS TO NOT DISTURB THE NORMAL FLOW OR REDUCE THE AREA.

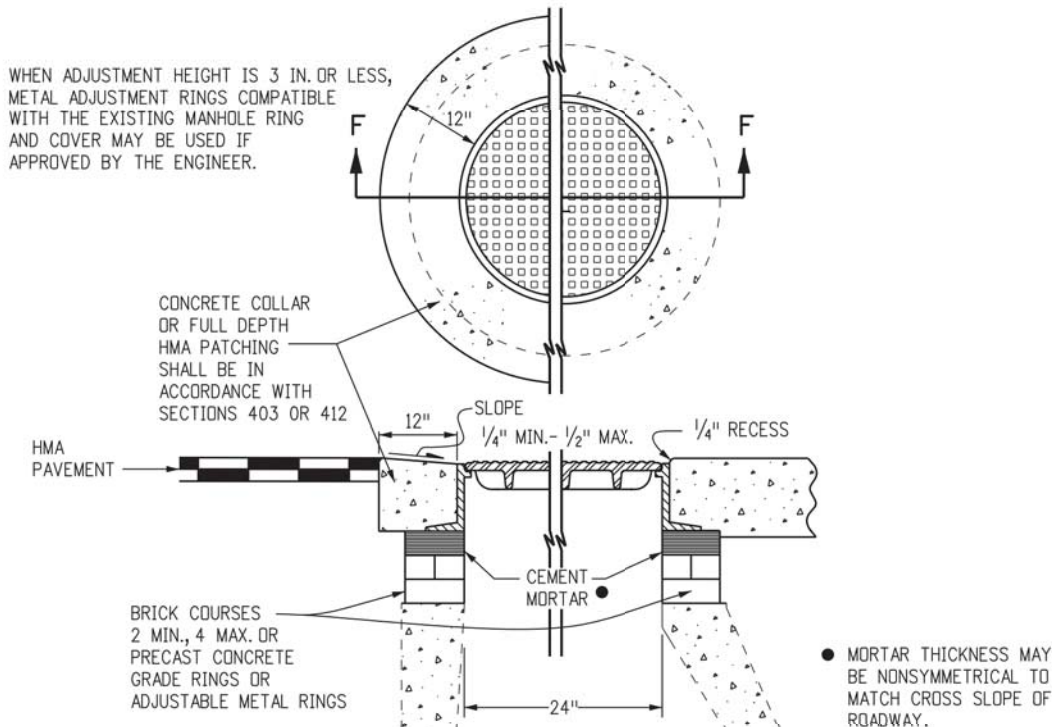

**SECTION F-F  
ADJUST MANHOLE 20 IN. OR LESS**

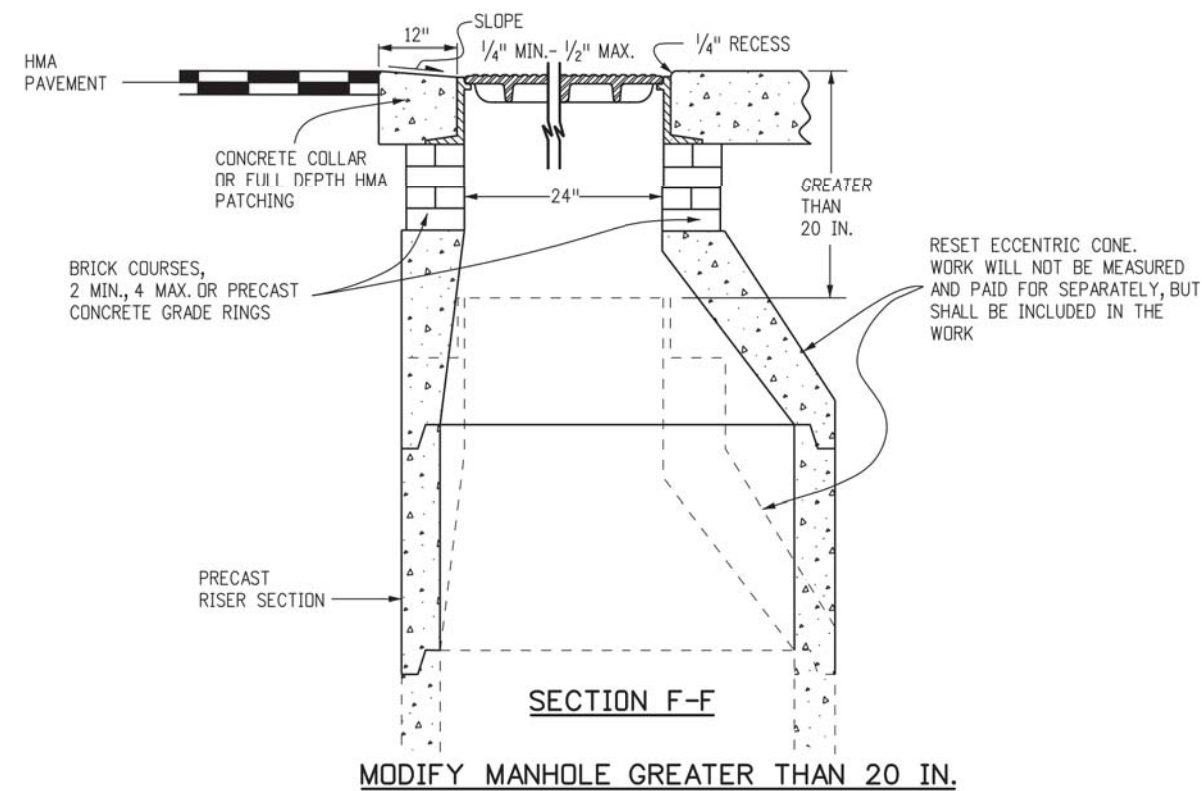

**SECTION F-F  
MODIFY MANHOLE GREATER THAN 20 IN.**

▲ WHEN FINAL GRADE IS PAVEMENT SURFACE, RECESS MANHOLE RING AND COVER 1/4" MIN. TO 1/2" MAX.

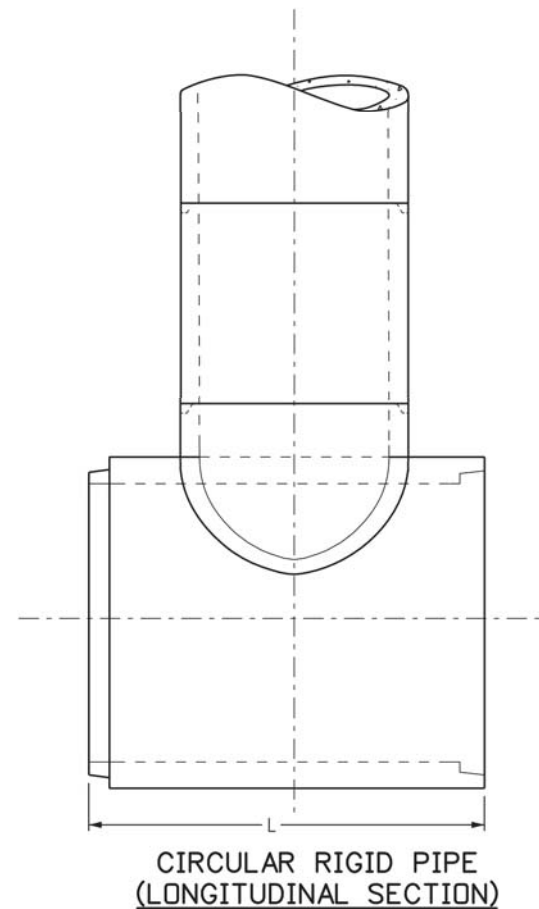

**CIRCULAR RIGID PIPE  
(LONGITUDINAL SECTION)**

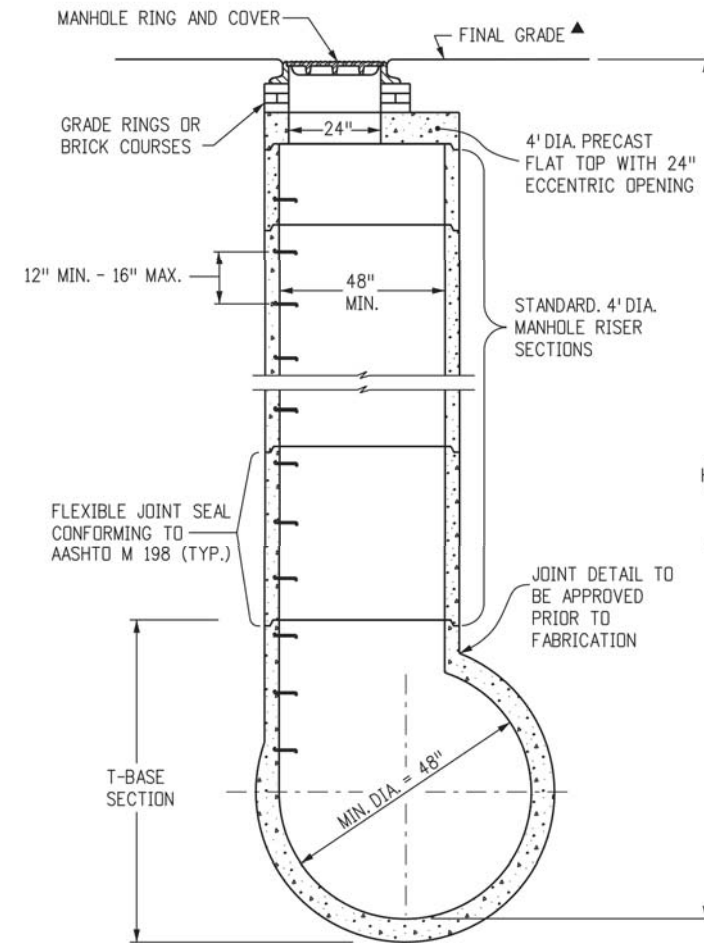

**CIRCULAR RIGID PIPE  
(TRANSVERSE SECTION)**

**MANHOLE T-BASE**

**Computer File Information**

Creation Date: 07/04/12 Initials: DD  
Last Modification Date: 07/04/12 Initials: LTA  
Full Path: www.coloradodot.info/business/designsupport  
Drawing File Name: 6040200303.dgn  
CAD Ver.: MicroStation V8 Scale: Not to Scale Units: English

**Sheet Revisions**

| Date: | Comments |
|-------|----------|
| (R-X) |          |
| (R-X) |          |
| (R-X) |          |
| (R-X) |          |

**Colorado Department of Transportation**

4201 East Arkansas Avenue  
Denver, Colorado 80222  
Phone: (303) 757-9083  
Fax: (303) 757-9820

Project Development Branch DD/LTA

**MANHOLES**

Issued By: Project Development Branch July 4, 2012

**STANDARD PLAN NO.**

M-604-20

Sheet No. 3 of 3







POND 001 EXPANSION

| NO. | BY  | PURPOSE | DATE    | CHKD |
|-----|-----|---------|---------|------|
| 1   | JBW | IFC     | 19JUN17 |      |
| 2   | JBW | IFC     | 21NOV17 |      |

SCALE

DATE  
JUNE 19, 217

DRAWN BY:  
SMY

CHECKED BY:  
SHK

FAA AIP NO:

WORK BREAKDOWN NO.

DESIGN CONTRACT NO.  
201418360

CONST. CONTRACT NO.  
201418360 TASK 5

VOLUME NO.  
1

SHEET TITLE  
DIVERSION STRUC.  
MODIFICATION  
GENERAL NOTES

SHEET NO.  
S1000

34 OF 61  
CADD FILE NO.  
GENNOTES

GENERAL NOTES:

- ALL DESIGN AND CONSTRUCTION WORK SHALL BE GOVERNED BY THE BUILDING CODE FOR THE CITY AND COUNTY OF DENVER, LATEST EDITION. THIS IS BASED ON THE INTERNATIONAL BUILDING CODE (IBC) OF THE INTERNATIONAL CODE COUNCIL WITH DENVER AMENDMENTS TO THIS CODE.
  - THIS CONTRACT SHALL BE BASED ON IBC 2015 AS AMENDED BY DENVER DATED 2016.
  - DEN DESIGN STANDARDS
  - FEDERAL AVIATION ADVISORY CIRCULARS
  - AASHTO LRFD BRIDGE DESIGN SPECIFICATIONS, 7TH EDITION WITH INTERIMS 2015 AND 2016
- ALL MATERIALS AND WORKMANSHIP SHALL CONFORM TO THE PROJECT SPECIFICATIONS, SPECIAL PROVISIONS, AND DESIGN REQUIREMENTS INCLUDED IN THE PLANS.
- THE STRUCTURES SHOWN ON THE DRAWINGS HAVE BEEN DESIGNED FOR STABILITY UNDER FINAL CONDITIONS ONLY. THESE PLANS DO NOT INCLUDE THE NECESSARY COMPONENTS OR EQUIPMENT FOR THE STRUCTURE'S STABILITY DURING CONSTRUCTION. THE CONTRACTOR IS RESPONSIBLE FOR ALL WORK RELATING TO CONSTRUCTION ERECTION METHODS, BRACING, SHORING, RIGGING, GUYS, SCAFFOLDING, FORMWORK, AND OTHER WORK AIDS REQUIRED TO SAFELY PERFORM THE WORK SHOWN.

DESIGN DATA:

- AASHTO LRFD BRIDGE DESIGN SPECIFICATIONS 7TH EDITION, 2014 WITH 2015 AND 2016 INTERIMS.
- APPENDIX B OF AC 150/5320-6F.
- DESIGN METHOD: ALLOWABLE STRESS DESIGN FOR FOUNDATION BEARING PRESSURES AND LOAD AND RESISTANCE FACTOR DESIGN FOR ALL OTHER ASPECTS.
- LIVE LOADS: NONE

SOIL DATA:

- SOILS PARAMETERS ARE BASED ON THE SOIL INVESTIGATION REPORT BY ROCKSOL PROJECT NO. 436.01 DATED 6/8/2017.
- THE GEOTECHNICAL INFORMATION INDICATES LEAN CLAY FILL OVER CLAYSTONE BEDROCK WITH MEDIUM TO HIGH SWELL POTENTIAL. BEDROCK WAS LOCATED AT AN APPROXIMATE ELEVATION OF 5336.00.
- SOIL PARAMETERS:

ALLOWABLE BEARING CAPACITY:

CLAYSTONE BEDROCK = 4,000 PSF  
ONE-THIRD INCREASE IS ALLOWED FOR TRANSIENT LOADING ONLY

BACKFILL LOADS:

BACKFILL SHALL BE SELECT STRUCTURAL BACKFILL  
UNIT WEIGHT OF SELECT STRUCTURAL BACKFILL = 125 PCF  
AT-REST LATERAL EARTH PRESSURE = 50 PCF  
WALLS FOR THE VAULTS DESIGNED FOR AT-REST LATERAL EARTH PRESSURES

- CONTACT THE DEN PROJECT MANAGER IMMEDIATELY IF SOIL OR BACKFILL CONDITIONS DO NOT SUPPORT THE ABOVE ASSUMPTIONS.

FOUNDATIONS:

- THE CONTRACTOR SHALL BE RESPONSIBLE FOR THE STABILITY OF THE STRUCTURE DURING CONSTRUCTION.
- SHORING OF EXCAVATION FOR WALLS SHALL BE IN ACCORDANCE WITH OSHA GUIDELINES.
- DESIGN, CONSTRUCTION AND INSTALLATION OF SHORING FOR EXCAVATIONS ARE THE CONTRACTOR'S RESPONSIBILITY.
- EXCAVATIONS FOR MAT FOUNDATIONS SHALL BE CLEANED OF ALL LOOSE MATERIAL. SOFT SPOTS SHALL BE CUT OUT AND FILLED WITH APPROVED FILL MATERIAL.
- A MOISTURE BARRIER (CONCRETE LEVELING PAD) SHALL BE PLACED BELOW THE FOOTINGS. SEE DRAWINGS.
- SUBGRADE EXCAVATIONS FOR VALVE PITS SHALL BE INSPECTED BY AN INDEPENDENT TESTING LABORATORY OBTAINED BY THE CONTRACTOR.

BACKFILL:

- BACKFILL SHALL BE SELECT STRUCTURAL BACKFILL CONFORMING TO ROCKSOL RECOMMENDATION AS FOLLOWS: SELECT STRUCTURAL BACKFILL SHALL BE A "CRUSHED" MATERIAL (NOT "ROUNDED" MATERIAL) CONFORMING TO THE GRADATION AND SPECIFICATION FOR CDOT CLASS 4 AGGREGATE BASE COURSE, OR EQUIVALENT.
- BACKFILL SHALL BE DISTRIBUTED IN LAYERS BROUGHT UP EQUALLY ON ALL SIDES OF THE STRUCTURE. EACH LAYER SHALL NOT EXCEED THE DEPTH NOTED IN THE SPECIFICATIONS, BEFORE SUCCESSIVE LAYERS ARE PLACES.

CONCRETE:

- CONCRETE SHALL HAVE A MINIMUM COMPRESSIVE STRENGTH OF 4,500 PSI AT 28 DAYS UNLESS OTHERWISE NOTED.
- CONCRETE SHALL CONFORM TO SPECIFICATION P-610.
- ALL CONCRETE JOINTS SUCH AS EXPANSION JOINTS, ISOLATION JOINTS, CONTROL JOINTS SHALL CONFORM TO THE DRAWINGS AND THE SPECIFICATIONS.
- ANY CONSTRUCTION JOINTS NOT SHOWN ON THE PLANS SHALL BE SUBMITTED TO THE DEN PROJECT MANAGER FOR APPROVAL PRIOR TO CONSTRUCTION.
- ROUGHEN AND CLEAN ALL CONSTRUCTION JOINTS IN WALLS AND SLABS AS SPECIFIED PRIOR TO PLACING ADJACENT CONCRETE.
- NO PRODUCTS CONTAINING ALUMINUM OR ANY OTHER MATERIAL INJURIOUS TO THE CONCRETE SHALL BE EMBEDDED IN THE CONCRETE.
- THE CONTRACTOR SHALL COORDINATE PLACEMENT OF ALL OPENINGS, DOWELS, SLEEVES, BOLTS, AND INSERTS PRIOR TO PLACEMENT OF CONCRETE.

REINFORCEMENT:

- REINFORCING STEEL SHALL CONFORM TO AMERICAN SOCIETY FOR TESTING AND MATERIALS (ASTM) A615, GRADE 60. FABRICATION AND PLACEMENT OF REINFORCING STEEL UNLESS OTHERWISE NOTED, SHALL SATISFY THE REQUIREMENTS OF AASHTO LRFD BRIDGE DESIGN SPECIFICATIONS, DATED 2014 WITH 2015 INTERIMS.
- ALL REINFORCING STEEL SHALL BE EPOXY COATED.
- REINFORCING STEEL SHALL CONFORM TO SPECIFICATION P-610.
- REINFORCING STEEL SHALL BE LAPPED AS SHOWN ON THE DRAWINGS.
- VERTICAL WALL BARS SHALL BE LAPPED WITH DOWELS FROM BASE SLABS AND EXTENDED INTO THE TOP FACE OF ROOF SLABS.
- ALL WALL CORNER AND WALL INTERSECTION REINFORCEMENT BARS SHALL BE CONTINUOUS AROUND CORNERS AND THROUGH COLUMNS OR PILASTERS. REINFORCEMENT SHALL BE EXTENDED INTO CONNECTING WALLS AND LAPPED ON THE OPPOSITE FACE OF THE CONNECTING WALLS.
- ALL BENDS, UNLESS OTHERWISE SHOWN, SHALL BE A 90 DEGREE STANDARD HOOK AS DEFINED IN AASHTO LRFD BRIDGE DESIGN SPECIFICATIONS, DATED 2014 WITH 2015 INTERIMS.
- UNLESS OTHERWISE SHOWN THE CLEAR COVER FOR REINFORCING BARS SHALL BE:
  - WHEN PLACE AGAINST SOIL = 3"
  - ALL OTHER LOCATIONS = 2"
  - CUT OR STOP ALL REINFORCING 2" FROM THE FACE OF CONCRETE.

STRUCTURAL STEEL:

- STRUCTURAL STEEL SHALL BE ASTM A-36, GALVANIZED.
- NO STRUCTURAL MEMBERS SHALL BE CUT FOR PIPES, DUCTS, ETC UNLESS SPECIFICALLY DETAILED OR APPROVED IN WRITING BY THE ENGINEER.
- CONNECTIONS - UNLESS OTHERWISE DETAILED SHALL BE STANDARD CONNECTIONS USING 3/4" DIAM. FASTENERS MADE IN ACCORDANCE WITH THE LATEST EDITION OF THE STEEL CONSTRUCTION MANUAL OF THE AMERICAN INSTITUTE OF STEEL CONSTRUCTION (AISC).
  - SHOP CONNECTIONS - MAY BE WELDED OR HIGH TENSILE BOLTED, ASTM A-325N.
  - FIELD CONNECTIONS - MAY BE BOLTED WITH HIGH TENSILE BOLTS, ASTM A-325N.
  - DESIGN AND CONSTRUCTION SHALL CONFORM TO THE "SPECIFICATION FOR DESIGN, FABRICATION AND ERECTION OF STRUCTURAL STEEL FOR BUILDINGS" OF AISC.

WELDING:

- ALL WELDING SHALL CONFORM TO THE "STRUCTURAL WELDING CODE AWS D1.1" BY THE AMERICAN WELDING SOCIETY, LATEST EDITION.

GRATING:

- FABRICATE GRATING IN APPROXIMATELY 2'-0" SECTIONS, LENGTH (SPAN) AS DETAILED.
- GALVANIZE AFTER FABRICATIONS.
- GRATING SHALL BE GALVANIZED STEEL WITH CAPACITY TO SPAN 5'-6" CARRYING AT LEAST A 1,563 LB CONCENTRATED LOAD OR UNIFORM LOAD OF AT LEAST 560 PSF, SIMILAR TO THE MCNICHOLS GHB GRATING 1 1/2" x 1/2" 19W4 OR EQUAL.

SPECIAL NOTES:

- REFER TO MECHANICAL AND ELECTRICAL DRAWINGS FOR EXACT LOCATION AND SIZE OF ALL PIPES, ANCHOR BOLTS, AND OPENINGS FOR EQUIPMENT FOR SLUICE GATE.
- SLUICE GATE ANCHORAGE AND SUPPORT REQUIREMENTS SHALL BE COORDINATED WITH SLUICE GATE MANUFACTURER.
- VISITS TO THE JOB SITE BY THE ENGINEER TO OBSERVE THE CONSTRUCTION DO NOT IN ANY WAY MEAN THAT THEY ARE GUARANTORS OF THE CONSTRUCTOR'S WORK, NOR RESPONSIBLE FOR COMPREHENSIVE OR SPECIAL INSPECTIONS, COORDINATION, SUPERVISION, NOR SAFETY AT THE JOB SITE.



POND 001 EXPANSION

| NO. | BY  | PURPOSE | DATE    | CHKD |
|-----|-----|---------|---------|------|
| 1   | JBW | IFC     | 19JUN17 |      |
| 2   | JBW | IFC     | 21NOV17 |      |

SCALE

DATE  
JUNE 19, 2017

DRAWN BY:  
SMY

CHECKED BY:  
SHK

FAA AIP NO.

WORK BREAKDOWN NO.

DESIGN CONTRACT NO.  
201418360

CONST. CONTRACT NO.  
201418360 TASK 5

VOLUME NO.  
1

SHEET TITLE  
DIVERSION STRUC.  
MODIFICATION -  
PLAN 1

SHEET NO.  
S1010

35 OF 61

CADD FILE NO.  
DIW PLAN

GENERAL NOTES:

- FOR STRUCTURAL GENERAL NOTES, SEE SHEET S1000.
- STOP OR CUT REINFORCEMENT 2" CLEAR FROM ALL EDGES OF CONCRETE OR PENETRATIONS.
- COORDINATE SLUICE GATE ANCHORAGE AND SUPPORT REQUIREMENTS WITH SLUICE GATE MANUFACTURER.
- PIPE PENETRATIONS ARE APPROXIMATE. SEE MECHANICAL DRAWINGS FOR HORIZONTAL AND VERTICAL LOCATION OF PIPE PENETRATIONS. CONTACT THE OWNER IMMEDIATELY IF THE EXISTING PIPE LOCATIONS DIFFER FROM WHAT IS SHOWN.

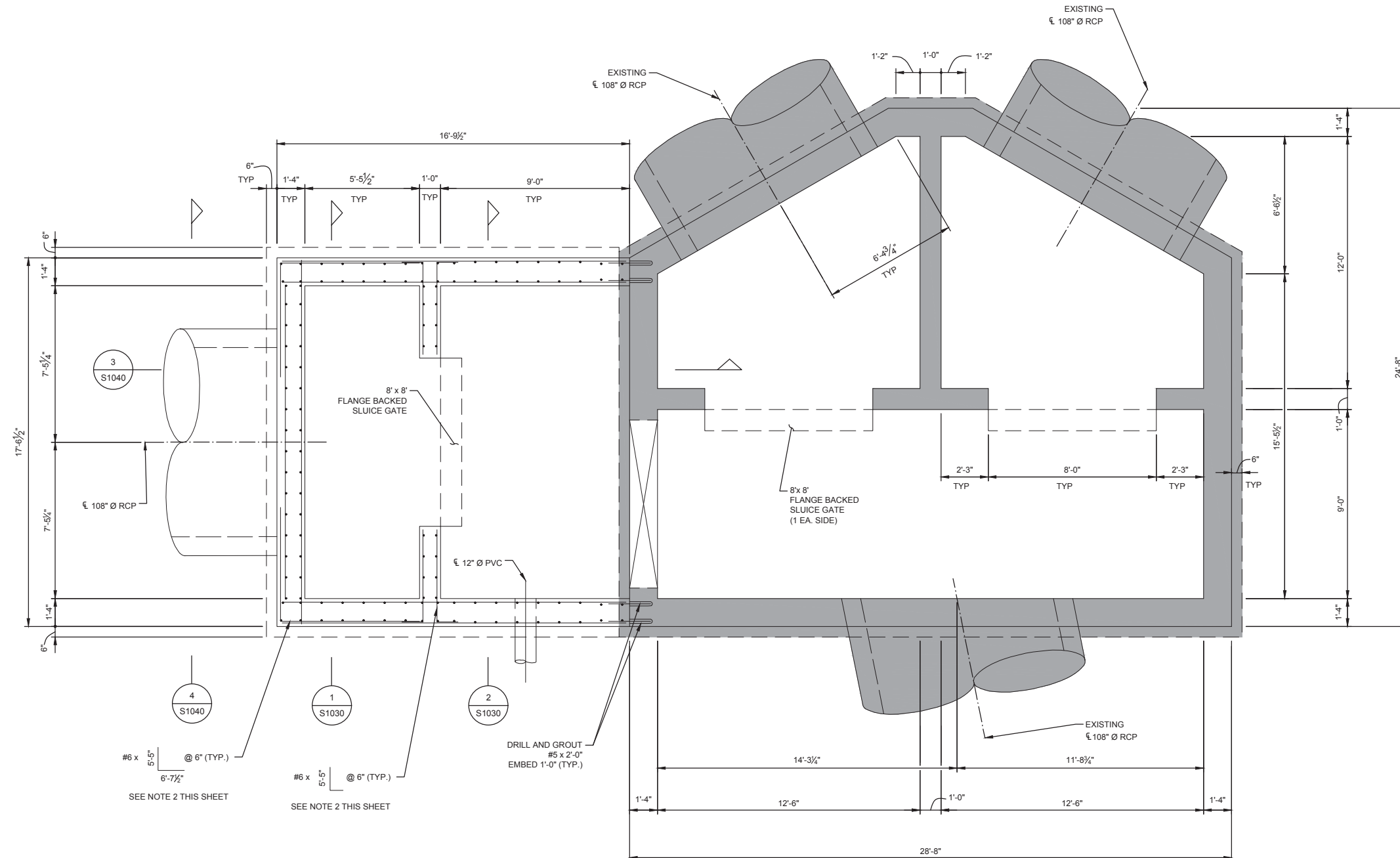

LEGEND

EXISTING STRUCTURE

A  
S1010  
PLAN - BOTTOM  
N.T.S.



| ISSUE RECORD |     |         |          |
|--------------|-----|---------|----------|
| NO.          | BY  | PURPOSE | DATE CKD |
| 1            | JBW | IFC     | 19JUN17  |
| 2            | JBW | IFC     | 21NOV17  |

SCALE

DATE JUNE 19, 2017

DRAWN BY: SMY

CHECKED BY: SHK

FAA AIP NO:

WORK BREAKDOWN NO.

DESIGN CONTRACT NO. 201418360

CONST. CONTRACT NO. 201418360 TASK 5

VOLUME NO. 1

SHEET TITLE  
**DIVERSION STRUC.  
MODIFICATION -  
PLAN 2**

SHEET NO. S1020

36 OF 61

CADD FILE NO.  
DIW PLAN

**GENERAL NOTES:**

1. FOR STRUCTURAL GENERAL NOTES, SEE SHEET S1000.
2. STOP OR CUT REINFORCEMENT 2" CLEAR FROM ALL EDGES OF CONCRETE OR PENETRATIONS.
3. COORDINATE SLUICE GATE ANCHORAGE AND SUPPORT REQUIREMENTS WITH SLUICE GATE MANUFACTURER.
4. PIPE PENETRATIONS ARE APPROXIMATE. SEE MECHANICAL DRAWINGS FOR HORIZONTAL AND VERTICAL LOCATION OF PIPE PENETRATIONS. CONTACT THE OWNER IMMEDIATELY IF THE EXISTING PIPE LOCATIONS DIFFER FROM WHAT IS SHOWN.



**LEGEND**

EXISTING STRUCTURE

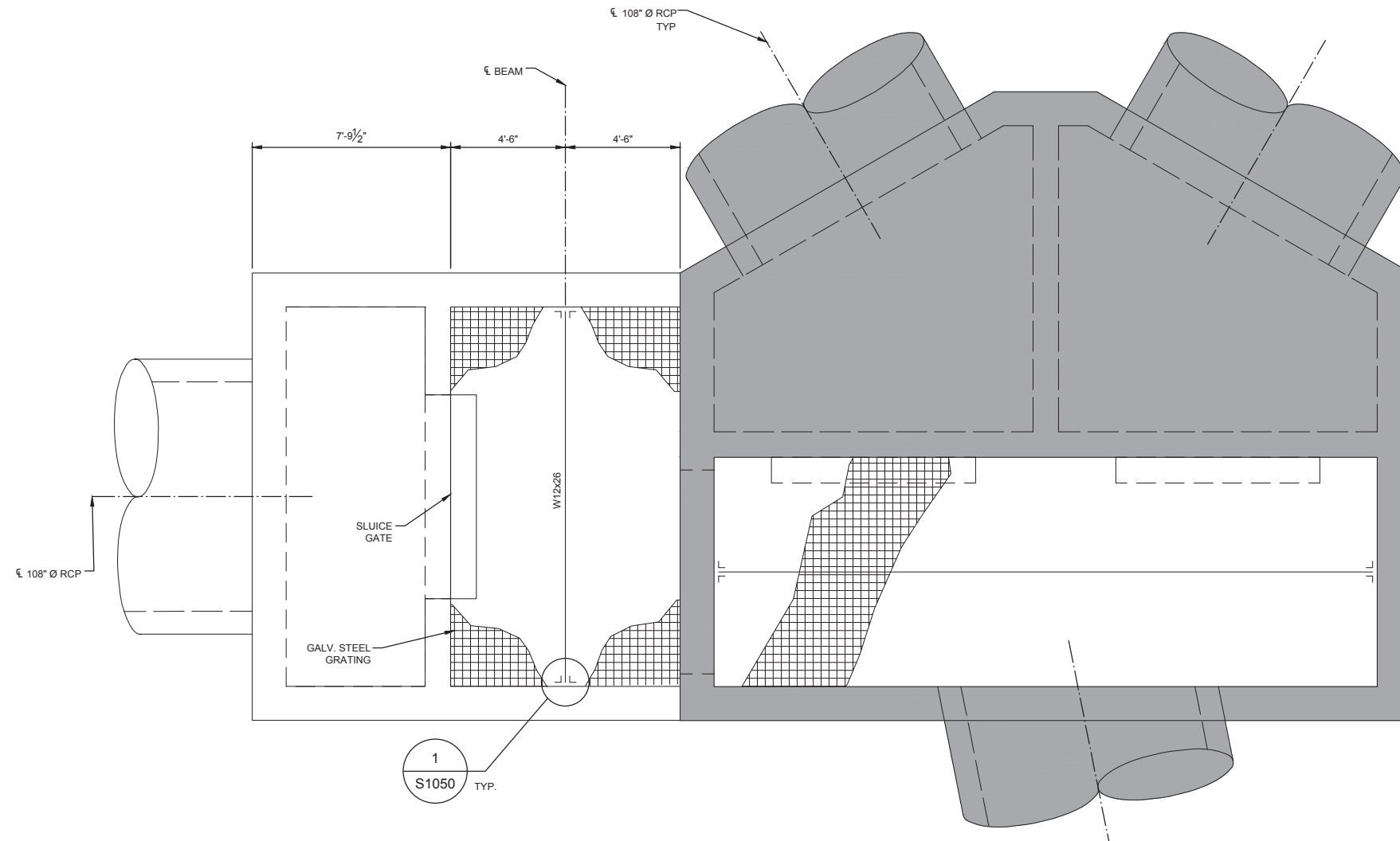

**B**  
S1020  
PLAN - TOP  
N.T.S.





POND 001 EXPANSION

| NO. | BY  | PURPOSE | DATE    | CHK |
|-----|-----|---------|---------|-----|
| 1   | JBW | IFC     | 19JUN17 |     |
| 2   | JBW | IFC     | 21NOV17 |     |

SCALE

DATE  
JUNE 19, 2017

DRAWN BY:  
SMY

CHECKED BY:  
SHK

FAA AIP NO.

WORK BREAKDOWN NO.

DESIGN CONTRACT NO.  
201418360

CONST. CONTRACT NO.  
201418360 TASK 5

VOLUME NO.  
1

SHEET TITLE  
DIVERSION STRUC.  
MODIFICATION -  
SECTION 1

SHEET NO.  
S1030

37 OF 61  
CADD FILE NO.  
DIW PLAN

X:\00\_KDC\_PROJECTS\K15009\_VIA DIA\_0\cadd\K15009.4\_DIW\_Pond\_001\20 DWG\DIW\_PLAN.dwg Nov 21, 2017 3:40pm jborg

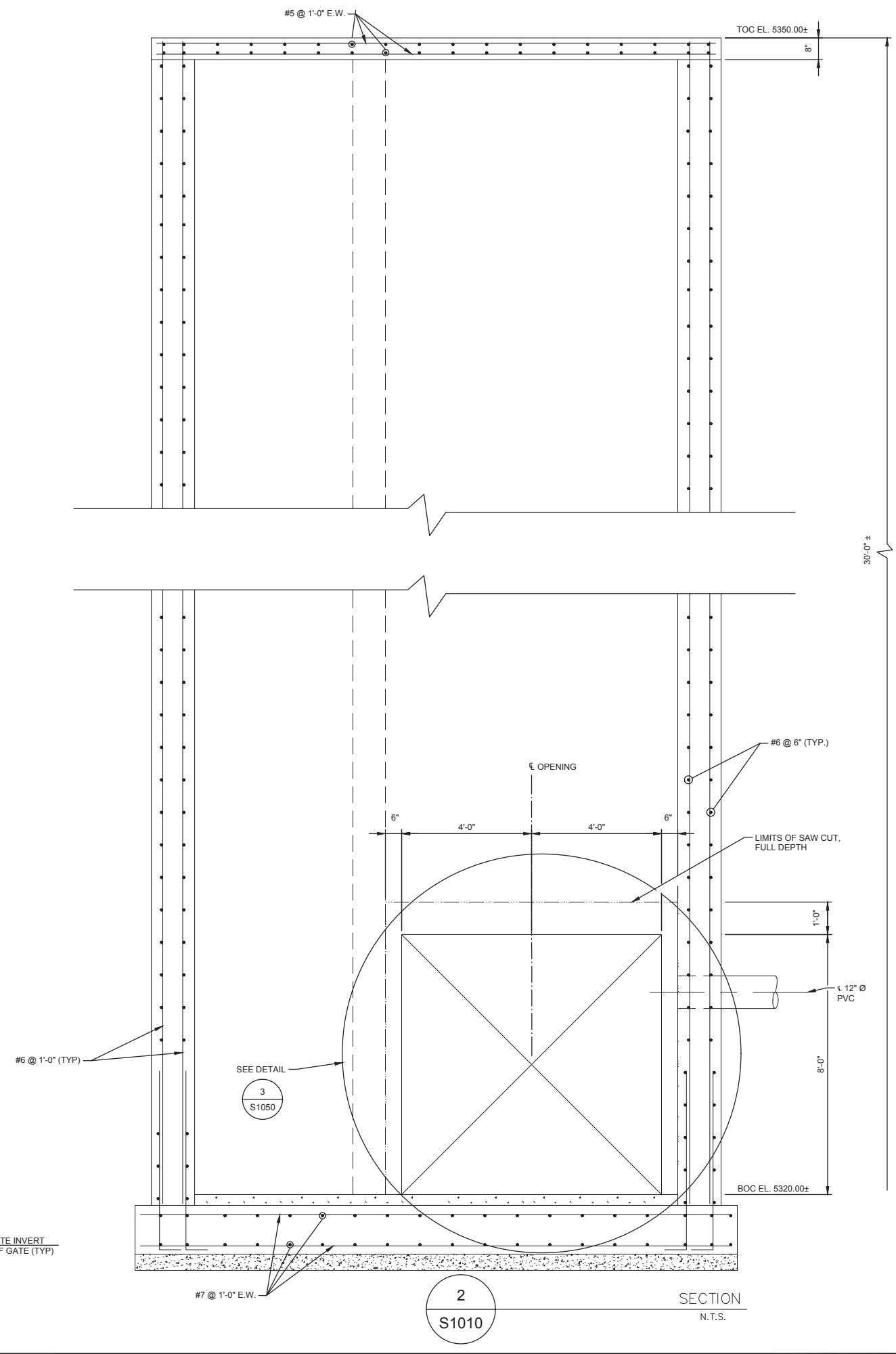
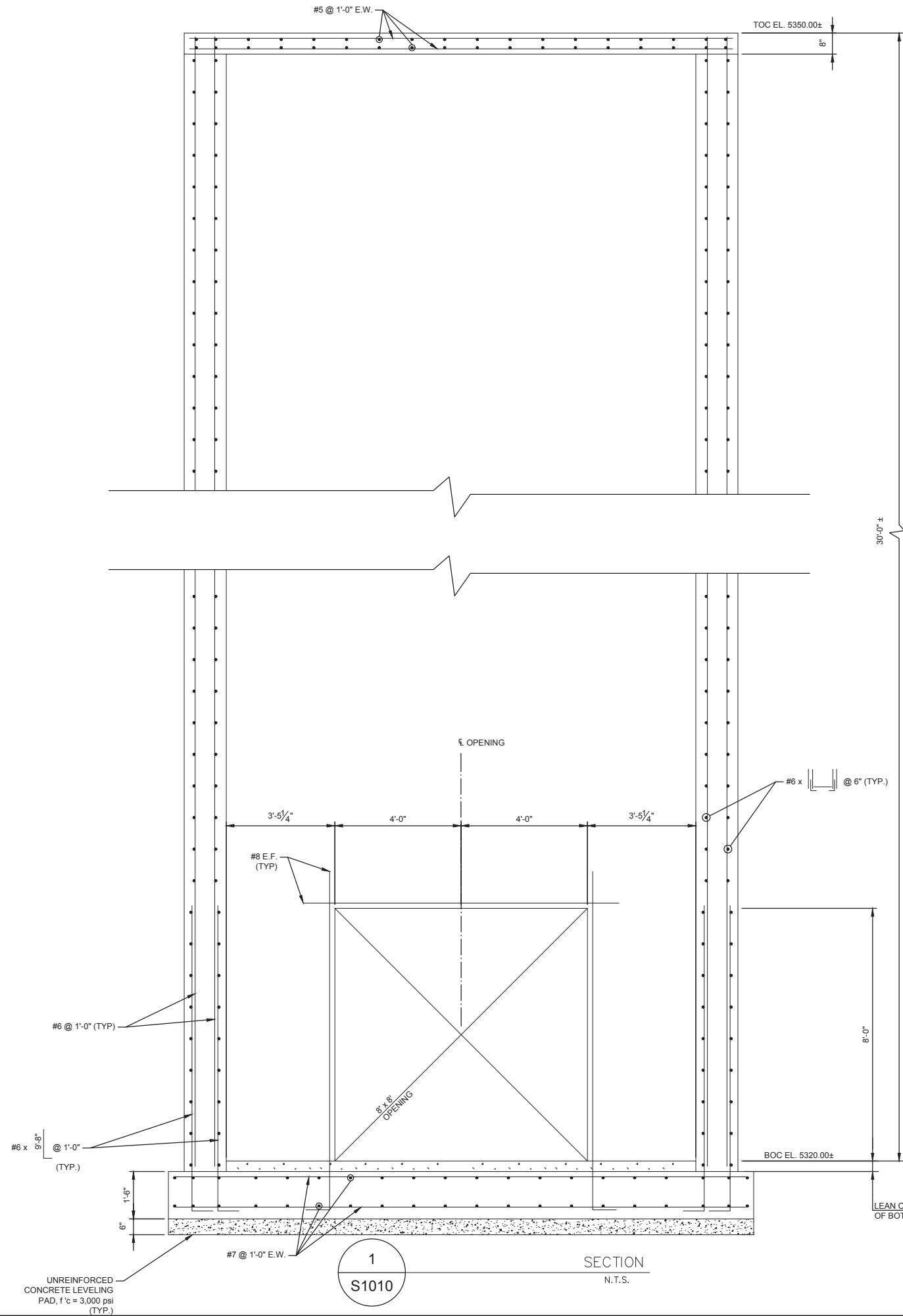

X:\00\_KDC\_PROJECTS\K15009\_VIA DIA OnCall\K15009.4 DIW Pond 001\20 DWG\DIW PLAN.dwg Nov 21, 2017 3:40pm Jong

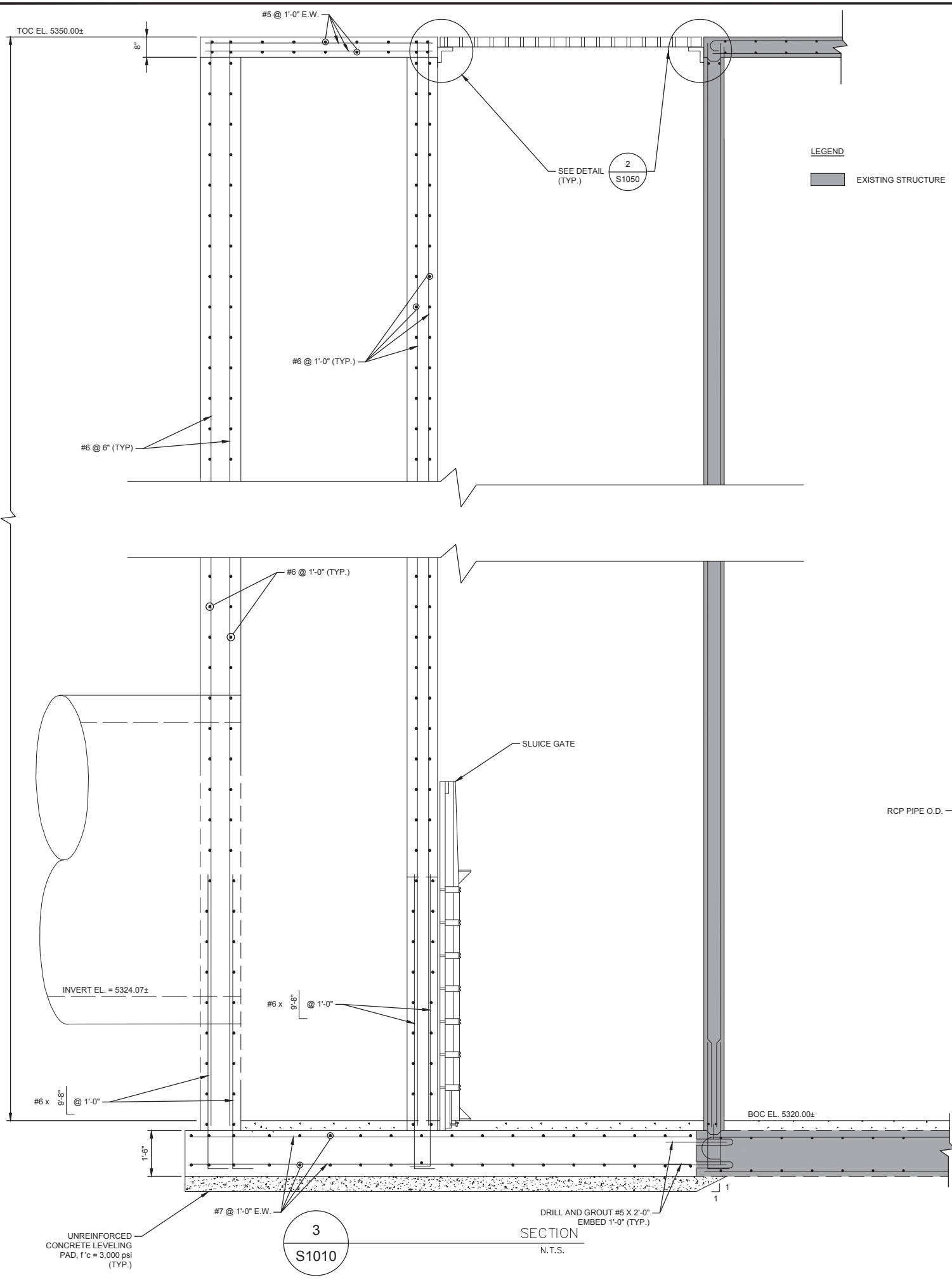

3  
S1010

SECTION  
N.T.S.

**GENERAL NOTES:**

1. FOR STRUCTURAL GENERAL NOTES, SEE SHEET S1000.
2. STOP OR CUT REINFORCEMENT 2" CLEAR FROM ALL EDGES OF CONCRETE OR PENETRATIONS.
3. COORDINATE SLUICE GATE ANCHORAGE AND SUPPORT REQUIREMENTS WITH SLUICE GATE MANUFACTURER.
4. PIPE PENETRATIONS ARE APPROXIMATE. SEE MECHANICAL DRAWINGS FOR HORIZONTAL AND VERTICAL LOCATION OF PIPE PENETRATIONS. CONTACT THE OWNER IMMEDIATELY IF THE EXISTING PIPE LOCATIONS DIFFER FROM WHAT IS SHOWN.

LEGEND  
 EXISTING STRUCTURE

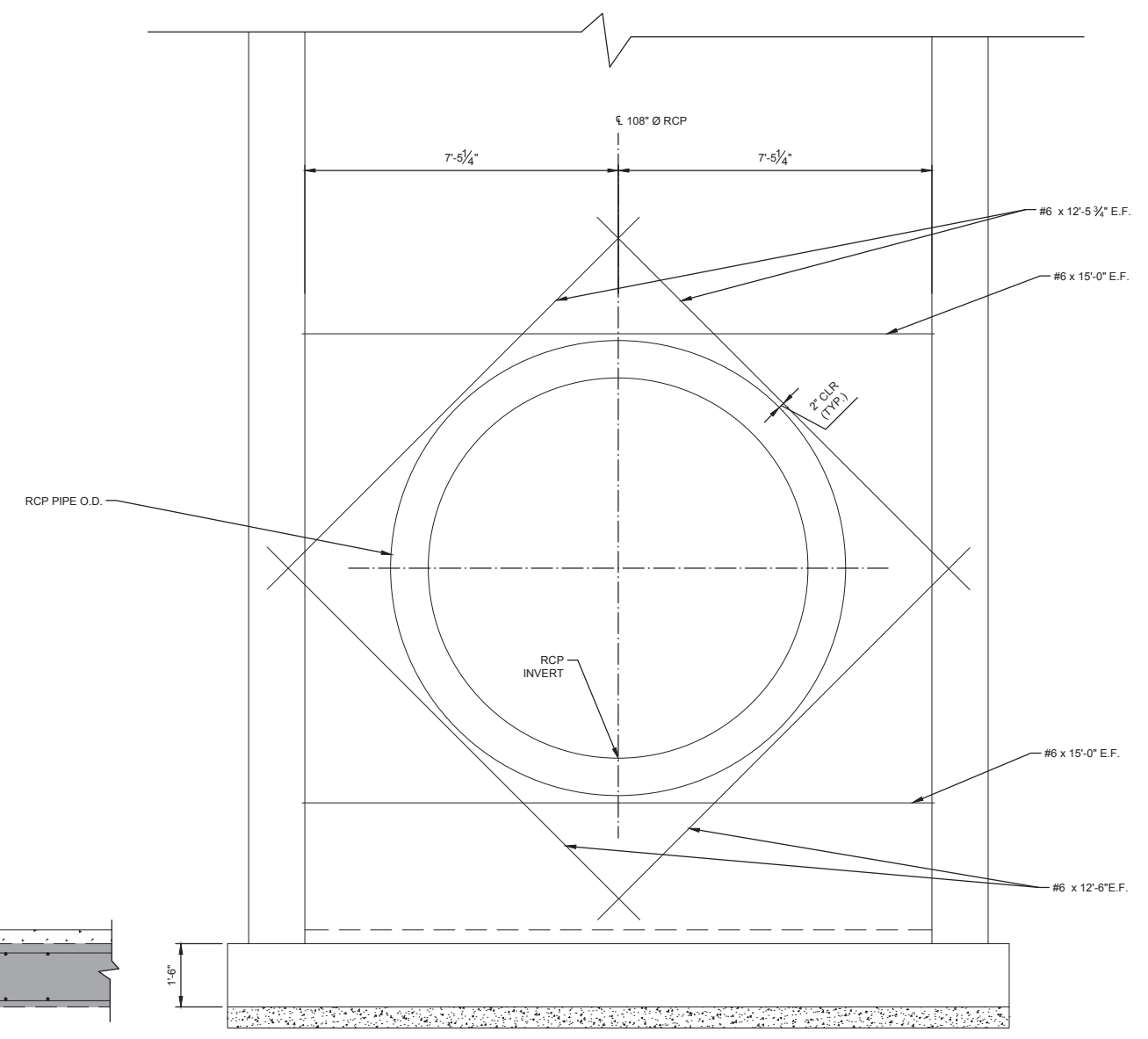

4  
S1010

SECTION  
N.T.S.



POND 001 EXPANSION

| NO. | BY  | PURPOSE | DATE    | CHKD |
|-----|-----|---------|---------|------|
| 1   | JBW | IFC     | 19JUN17 |      |
| 2   | JBW | IFC     | 21NO17  |      |

SCALE

DATE

JUNE 19, 2017

DRAWN BY: SMY

CHECKED BY: SHK

FAA AIP NO:

WORK BREAKDOWN NO.

DESIGN CONTRACT NO.

201418360

CONST. CONTRACT NO.

201418360 TASK 5

VOLUME NO.

1

SHEET TITLE  
**DIVERSION STRUC.  
 MODIFICATION -  
 SECTION 2**

SHEET NO.

S1040

38 OF 61

CADD FILE NO.

DIW PLAN



POND 001 EXPANSION

| NO. | BY  | PURPOSE | DATE    | CHKD |
|-----|-----|---------|---------|------|
| 1   | JBW | IFC     | 19JUN17 |      |
| 2   | JBW | IFC     | 21NOV17 |      |

SCALE

DATE  
JUNE 19, 2017

DRAWN BY:  
SMY

CHECKED BY:  
SHK

FAA AIP NO.

WORK BREAKDOWN NO.

DESIGN CONTRACT NO.  
201418360

CONST. CONTRACT NO.  
201418360 TASK 5

VOLUME NO.  
1

SHEET TITLE  
DIVERSION STRUC.  
MODIFICATION -  
DETAILS

SHEET NO.  
S1050

39 OF 61

CADD FILE NO.  
DIW PLAN

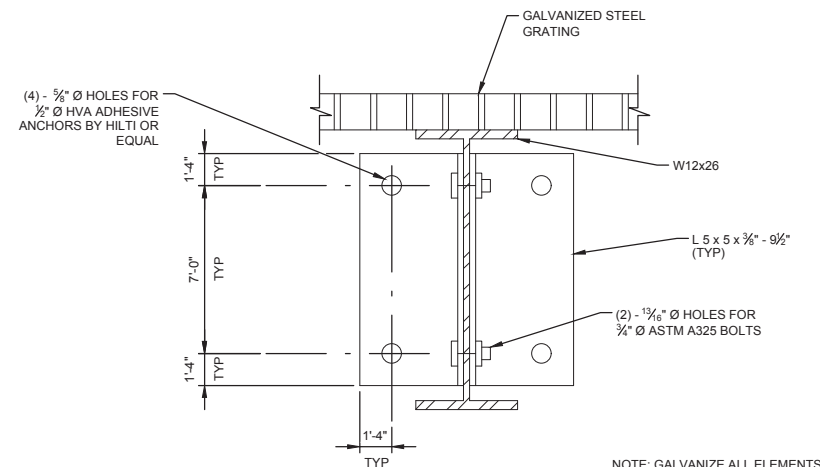

NOTE: GALVANIZE ALL ELEMENTS

1  
S1020

DETAIL  
N.T.S.

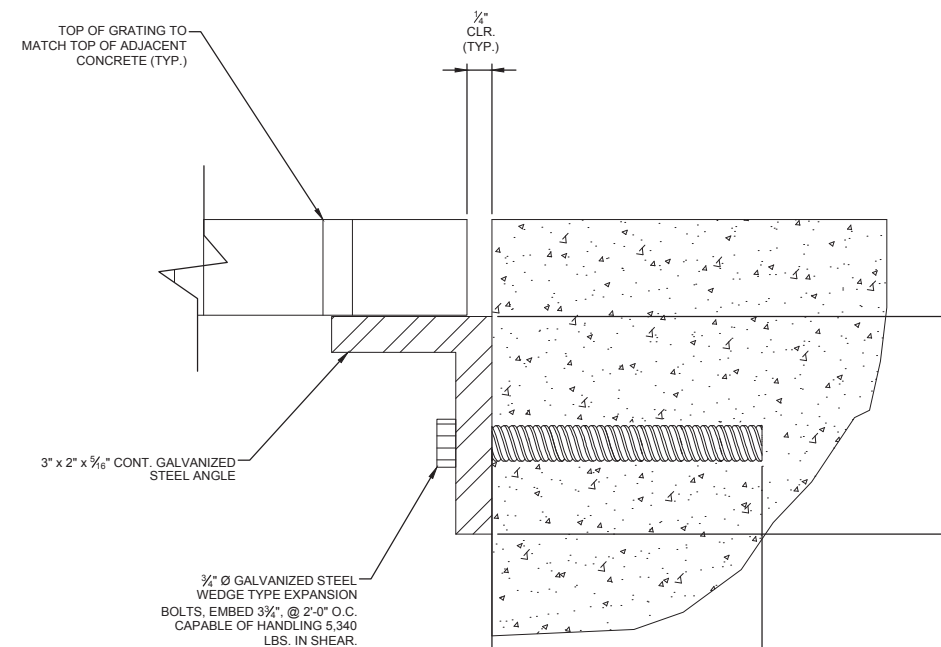

2  
S1040

DETAIL  
N.T.S.

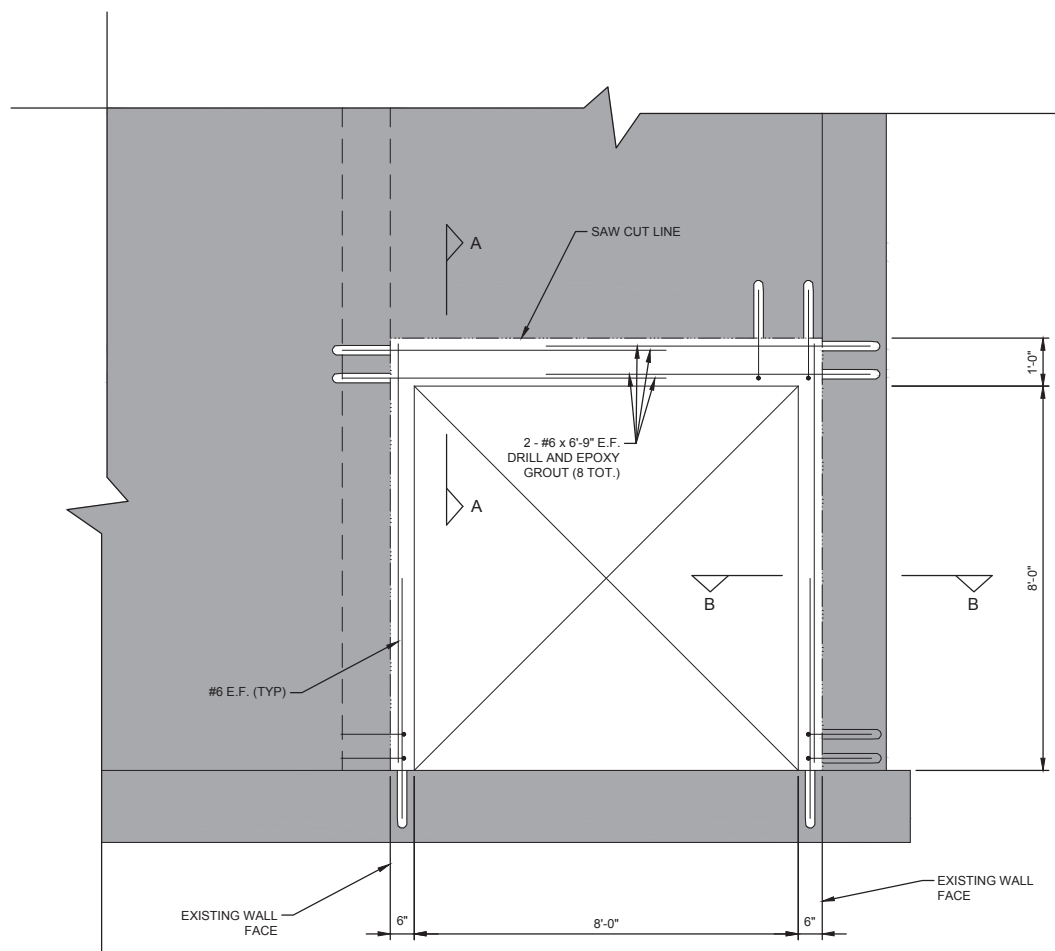

LEGEND  
EXISTING STRUCTURE

3  
S1030

DETAIL  
N.T.S.

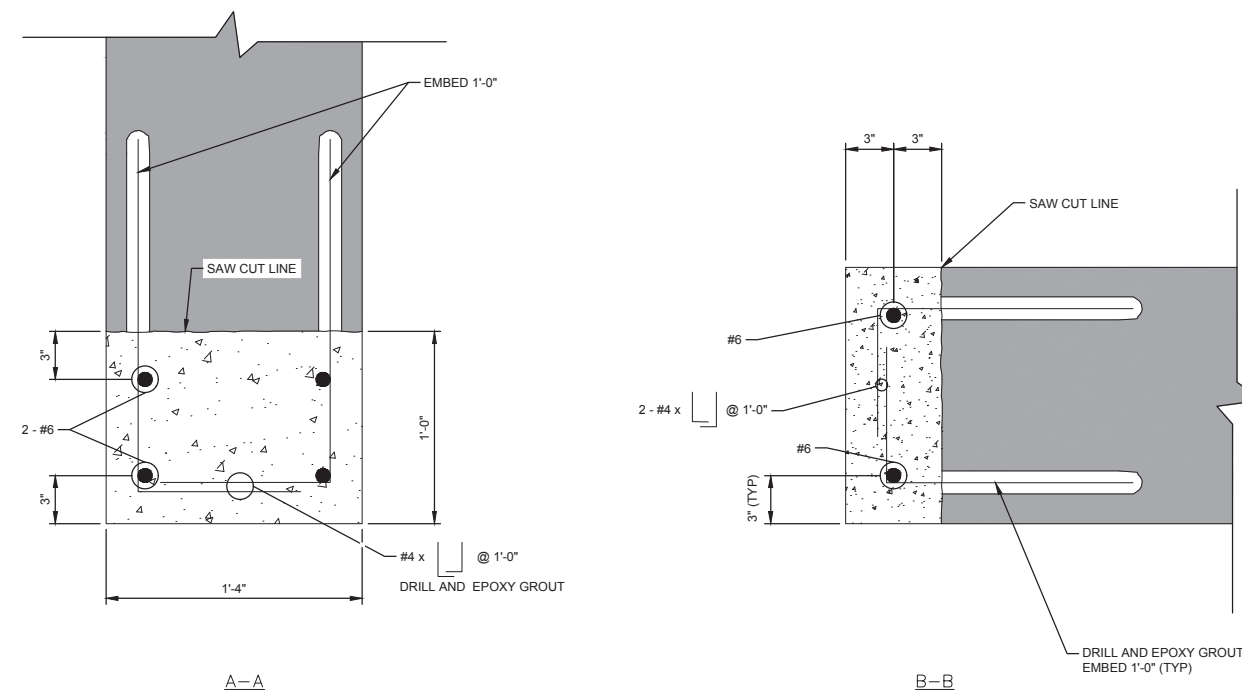

X:\00\_KDC\_PROJECTS\15009\_WA\_DIA\_0ncall\15009.4\_DIW\_Pond\_001\20\_DWG\DIW\_PLAN.dwg Nov 21, 2017 3:41pm Jong

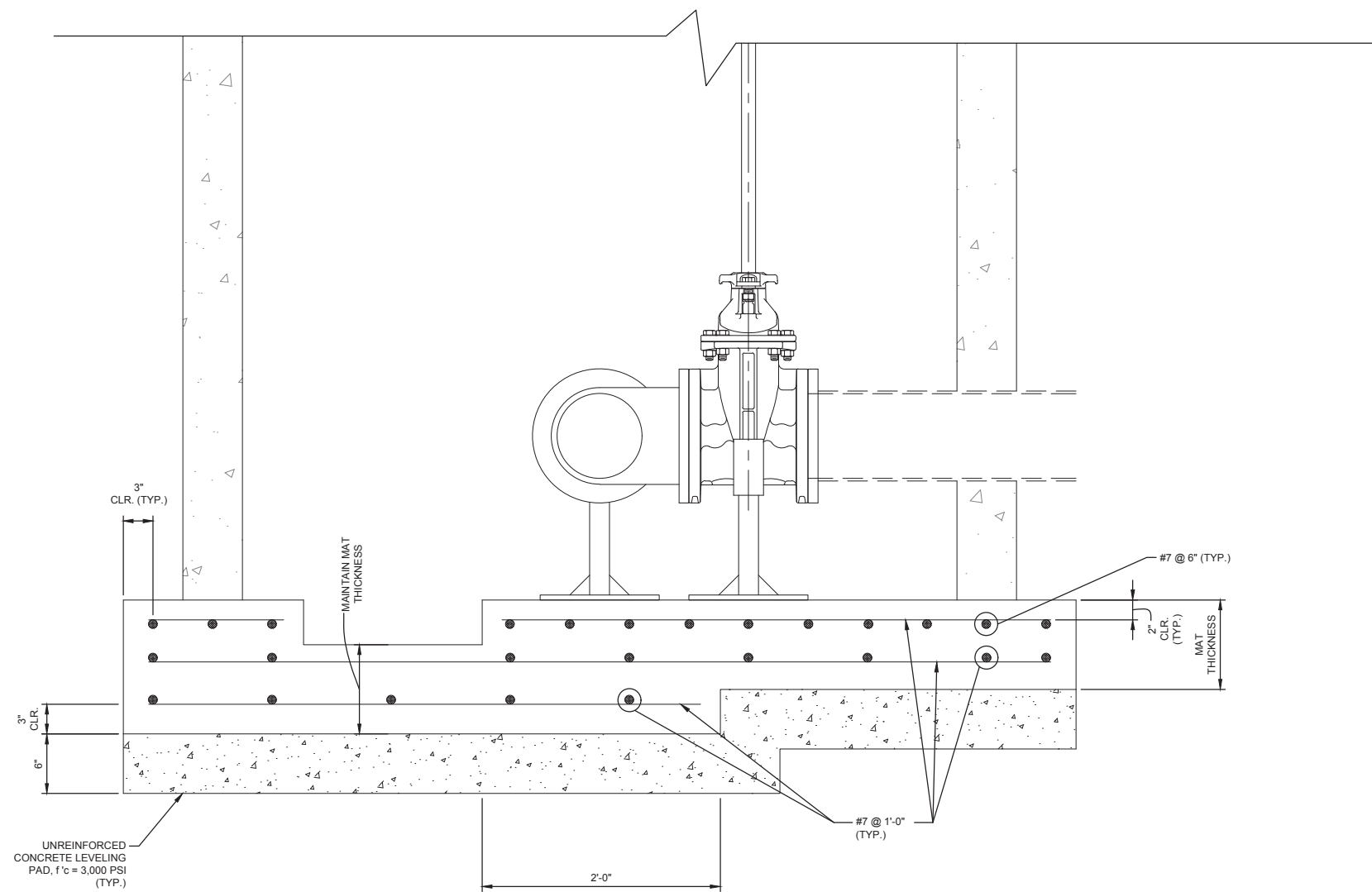

1  
S1060

FOOTING DETAIL  
N.T.S.



POND 001 EXPANSION

| NO. | BY  | PURPOSE | DATE   | CKD |
|-----|-----|---------|--------|-----|
| 1   | JBW | IFC     | 19JN17 |     |
| 2   | JBW | IFC     | 21NO17 |     |

SCALE

DATE  
JUNE 19, 2017

DRAWN BY:  
SMY

CHECKED BY:  
SHK

FAA AIP NO.

WORK BREAKDOWN NO.

DESIGN CONTRACT NO.  
201418360

CONST. CONTRACT NO.

201418360 TASK 5

VOLUME NO.

1

SHEET TITLE

MANHOLE BASE

DETAIL

SHEET NO.

S1060

40 OF 61

CADD FILE NO.

DIW PLAN



| NO. | BY  | PURPOSE | DATE   | CHKD |
|-----|-----|---------|--------|------|
| 1   | JBW | IFC     | 28SE17 |      |
| 2   | JBW | IFC     | 21NO17 |      |

SCALE

DATE

SEPTEMBER 28, 2017

DRAWN BY:

SMY

CHECKED BY:

SHK

FAA AIP NO.

WORK BREAKDOWN NO.

DESIGN CONTRACT NO.

201418360

CONST. CONTRACT NO.

201418360 TASK 5

VOLUME NO.

1

SHEET TITLE

DIW CONC. HEADER

& WINGWALL-

LAYOUT & DETAILS

SHEET NO.

S1070

40A OF 61

CADD FILE NO.

DIW POND WALL\_PLAN

**GENERAL NOTES:**

1. CONFORM TO GENERAL NOTES ON SHEET S1000 EXCEPT AS NOTED HEREIN.
2. SEE CIVIL DRAWINGS FOR ADDITIONAL HEADWALL AND WINGWALL DETAILS
3. STOP OR CUT ALL REINFORCEMENT 2" FROM THE FACE OF CONCRETE.

**DESIGN DATA:**

1. IBC 2015 AND DENVER AMENDMENTS 2016.
2. APPENDIX B OF AC 150/5320-6F.
3. DESIGN METHOD: ALLOWABLE STRESS DESIGN FOR FOUNDATION BEARING PRESSURES AND LOAD FACTOR DESIGN FOR ALL OTHER ASPECTS.
4. LIVE LOADS: NONE

**SOIL DATA:**

1. SOILS PARAMETERS ARE BASED ON THE SOIL INVESTIGATION REPORT BY ROCKSOL PROJECT NO. 436.01 DATED 6/8/2017.
2. THE GEOTECHNICAL INFORMATION INDICATES CLAYSTONE AND SANDSTONE BEDROCK WITH LOW SWELL POTENTIAL. BEDROCK WAS LOCATED AT AN APPROXIMATE ELEVATION OF 5034.00 FOR BORE HOLES 3, 4, 5, AND 6.
3. SOIL PARAMETERS:

**ALLOWABLE BEARING CAPACITY:**

SANDSTONE BEDROCK = 4,000 PSF  
ONE-THIRD INCREASE IS ALLOWED FOR TRANSIENT LOADING ONLY

**BACKFILL LOADS:**

UNIT WEIGHT OF STRUCTURAL BACKFILL = 130 PCF  
ACTIVE LATERAL EARTH PRESSURE = 45 PCF

4. CONTACT THE DEN PROJECT MANAGER IMMEDIATELY IF SOIL OR BACKFILL CONDITIONS DO NOT SUPPORT THE ABOVE ASSUMPTIONS.

**BACKFILL:**

1. BACKFILL SHALL BE STRUCTURAL BACKFILL CLASS 1 PER CDOT SPECIFICATIONS AND SHALL NOT BE PAID FOR SEPARATELY BUT SHALL BE INCLUDED IN THE WORK FOR THE WALLS.

**EXCAVATION:**

1. IF SANDSTONE BEDROCK IS ENCOUNTERED, IT WILL WEATHER EASILY WHEN EXPOSED. ALL LOOSE MATERIAL SHALL BE REMOVED PRIOR TO PLACEMENT OF CONCRETE.

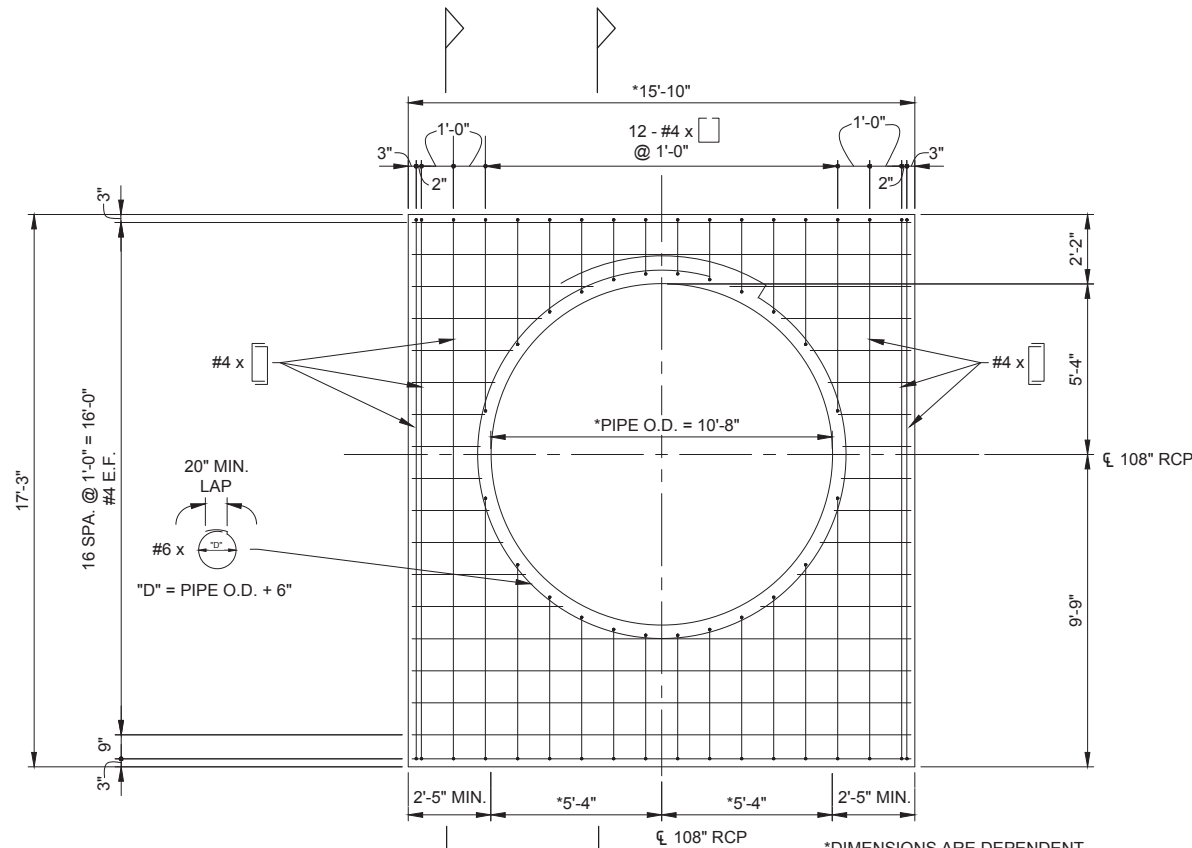
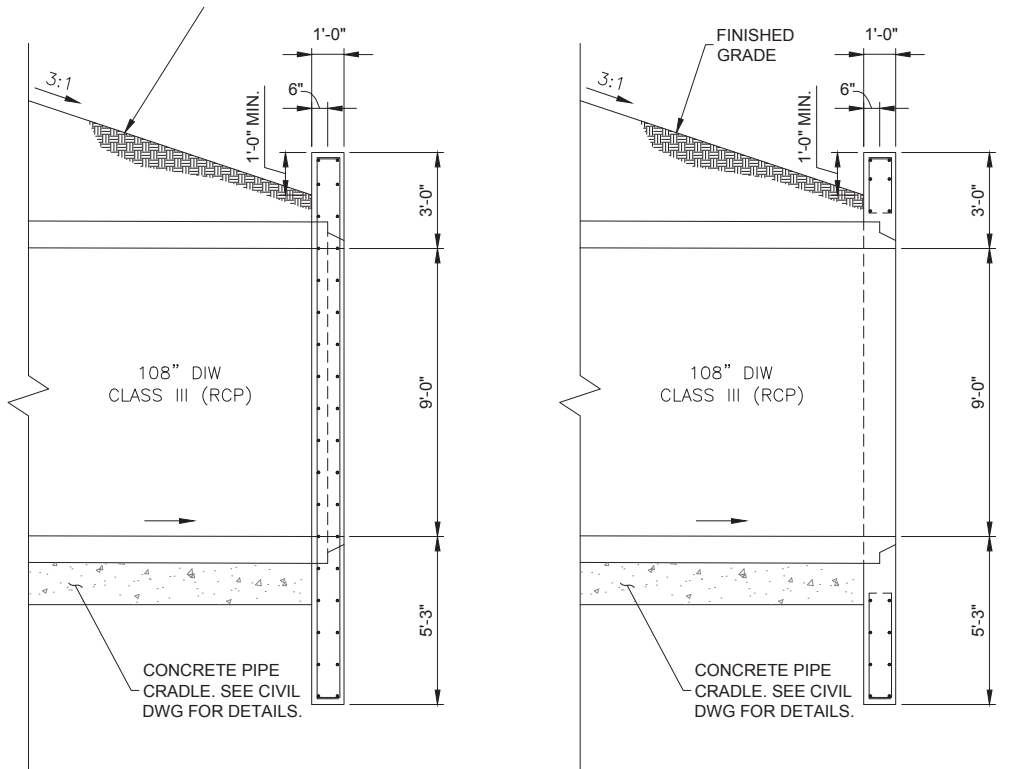
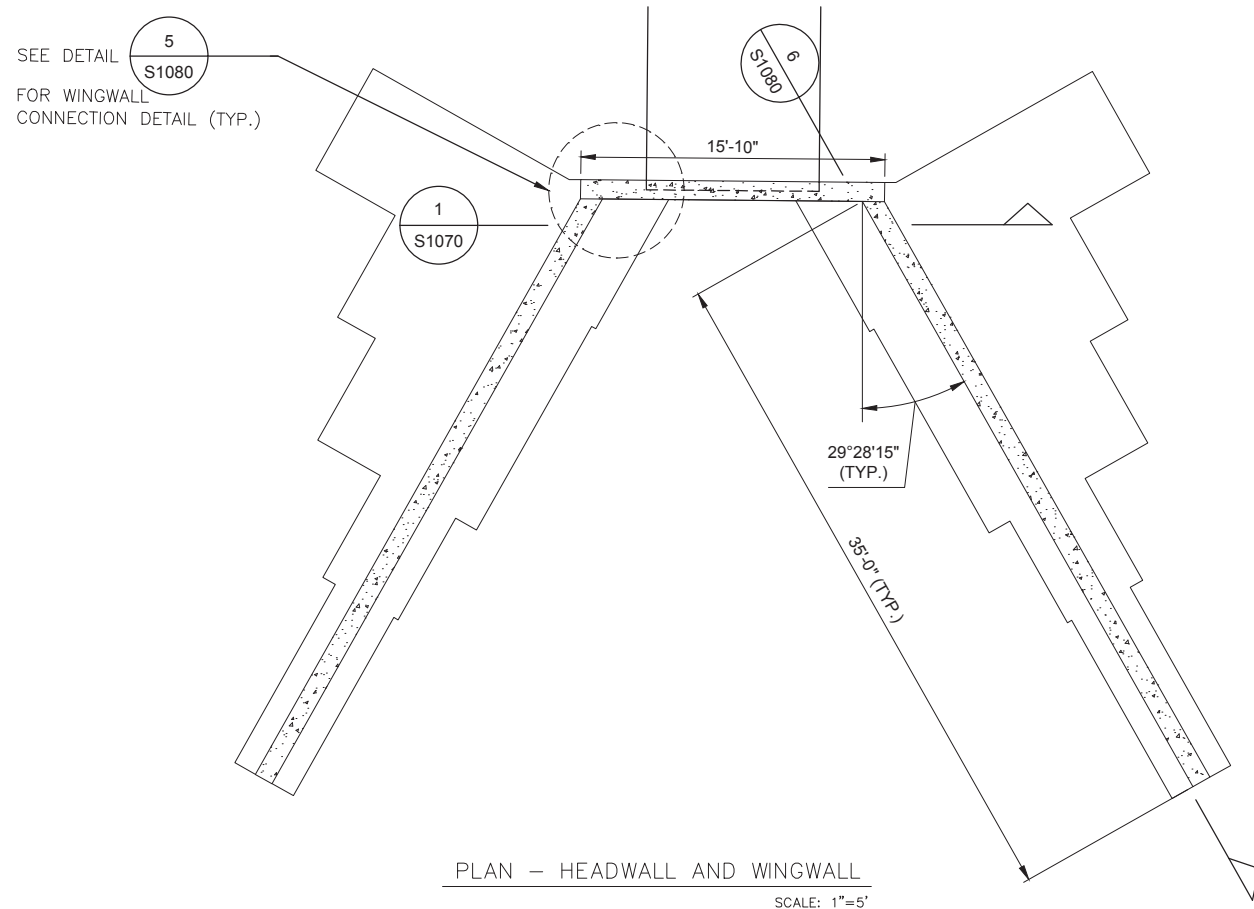

\*DIMENSIONS ARE DEPENDENT ON PIPE O.D. VERIFY WITH PIPE MANUFACTURER PRIOR TO CONSTRUCTION

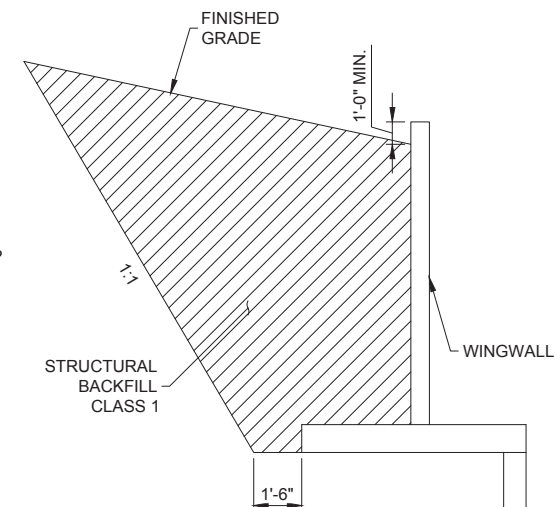

4 S1080 STRUCTURAL BACKFILL - DETAIL  
N.T.S.

2 S1070 SECTION - HEADWALL  
SCALE: 1"=3'

3 S1070 SECTION - HEADWALL  
SCALE: 1"=3'

1 S1070 ELEVATION - HEADWALL  
SCALE: 1"=2'

X:\00\_KDC\_PROJECTS\K15009 - AIA DIA. OnCall\K15009.5 DIW Pond Wall\20 DWG\DIW Pond Wall\_Plan.dwg Nov 21, 2017 - 3:36pm Jang



| NO. | BY  | PURPOSE | DATE   | CHKD |
|-----|-----|---------|--------|------|
| 1   | JBW | IFC     | 28SE17 |      |
| 2   | JBW | IFC     | 21NO17 |      |

SCALE

DATE

SEPTEMBER 28, 2017

DRAWN BY:

SMY

CHECKED BY:

SHK

FAA AIP NO.

WORK BREAKDOWN NO.

DESIGN CONTRACT NO.

201418360

CONST. CONTRACT NO.

201418360 TASK 5

VOLUME NO.

1

SHEET TITLE

DIW CONC. HEADER

& WINGWALL -

DETAILS

SHEET NO.

S1080

40B OF 61

CADD FILE NO.

DIW POND WALL\_PLAN

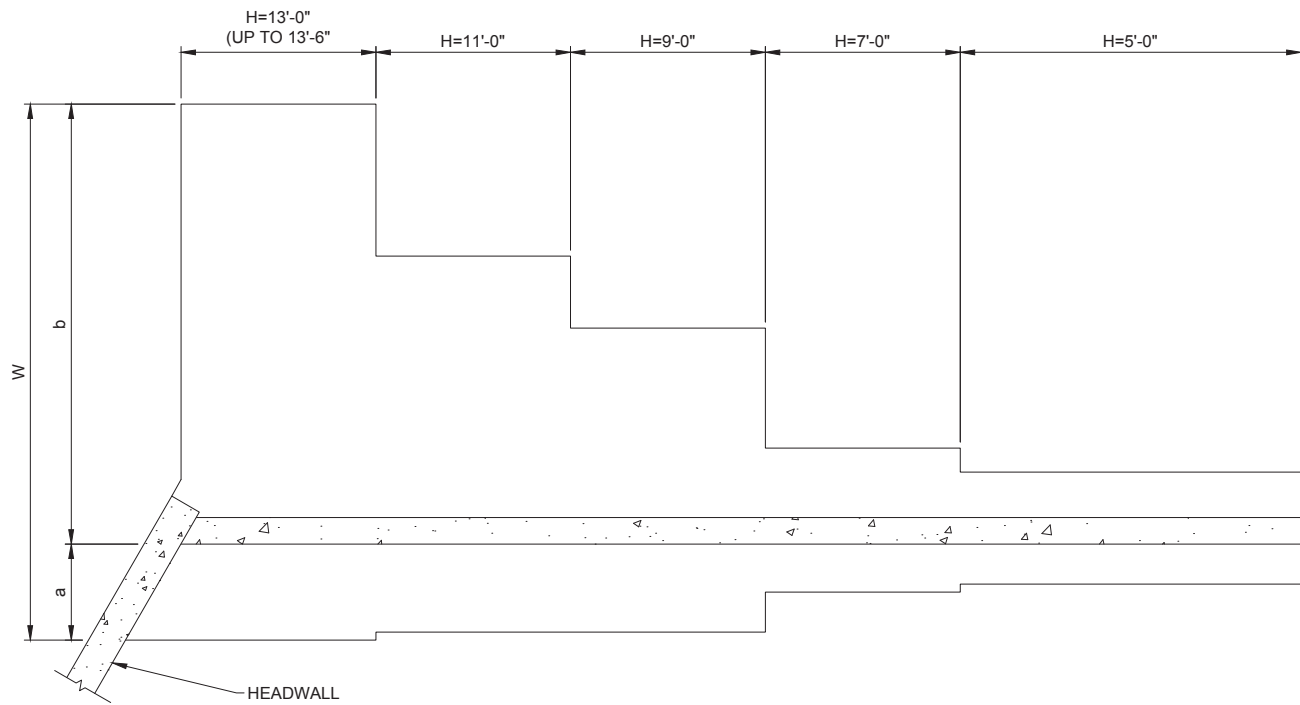

LAYOUT - WINGWALL  
SCALE: 1"=3'

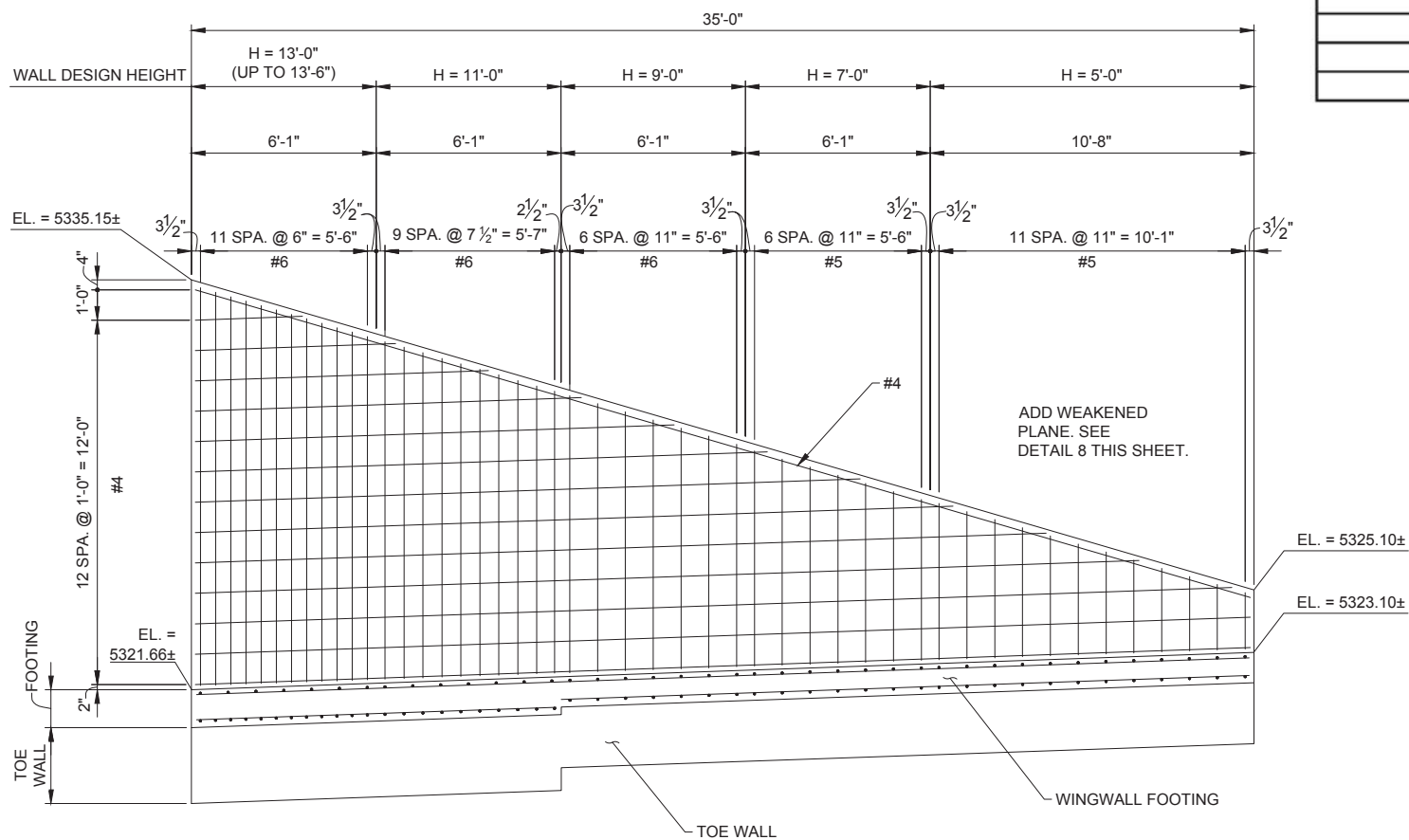

6  
S1070  
ELEVATION - WINGWALL  
SCALE: 1"=3'

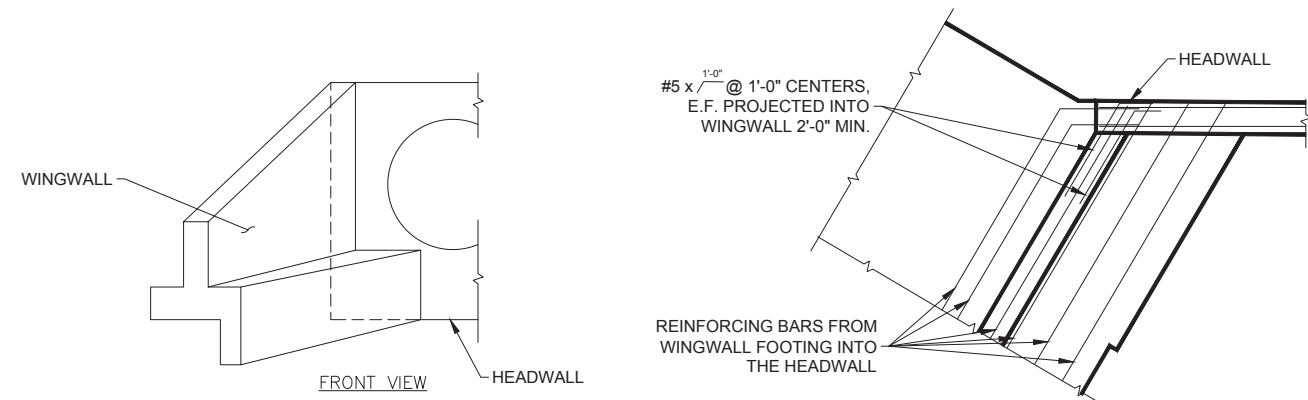

5  
S1010  
WINGWALL CONNECTION  
N.T.S.

| Wall Design Height (H) | 13.00' (Up to 13.5') | 11.00'    | 9.00'     | 7.00'     | 5.00'     |
|------------------------|----------------------|-----------|-----------|-----------|-----------|
| T (in)                 | 15.00                | 15.00     | 12.00     | 12.00     | 12.00     |
| a (ft)                 | 3.00                 | 2.75      | 2.75      | 1.50      | 1.25      |
| b (ft)                 | 13.75                | 9.00      | 6.75      | 3.00      | 2.25      |
| W (ft)                 | 16.75                | 11.75     | 9.50      | 4.50      | 3.50      |
| KD (in)                | 30.00                | 30.00     | 24.00     | 24.00     | 24.00     |
| KX (ft)                | 15.75                | 10.75     | 8.50      | 3.50      | 2.50      |
| KW (ft)                | 1.00                 | 1.00      | 1.00      | 1.00      | 1.00      |
| Thickness of Wall (in) | 10.00                | 10.00     | 10.00     | 10.00     | 10.00     |
| <b>Bars:</b>           |                      |           |           |           |           |
| C                      | # 6 @ 6"             | # 6 @ 9"  | # 6 @ 12" | # 5 @ 12" | # 5 @ 12" |
| C2                     | # 6 @ 6"             | # 6 @ 9"  | # 6 @ 12" | # 5 @ 12" | # 5 @ 12" |
| B1                     | # 6 @ 6"             | # 6 @ 9"  | # 6 @ 12" | # 5 @ 12" | # 5 @ 12" |
| d                      | # 5 @ 12"            | # 5 @ 12" | # 5 @ 12" | # 4 @ 12" | # 4 @ 12" |
| L (in)                 | 37.00"               | 37.00"    | 37.00"    | 25.00"    | 25.00"    |
| E                      | # 5 @ 12"            | # 5 @ 12" | # 4 @ 12" | # 4 @ 12" | # 4 @ 12" |

7  
S1080  
WINGWALL DESIGN HEIGHT TABLE

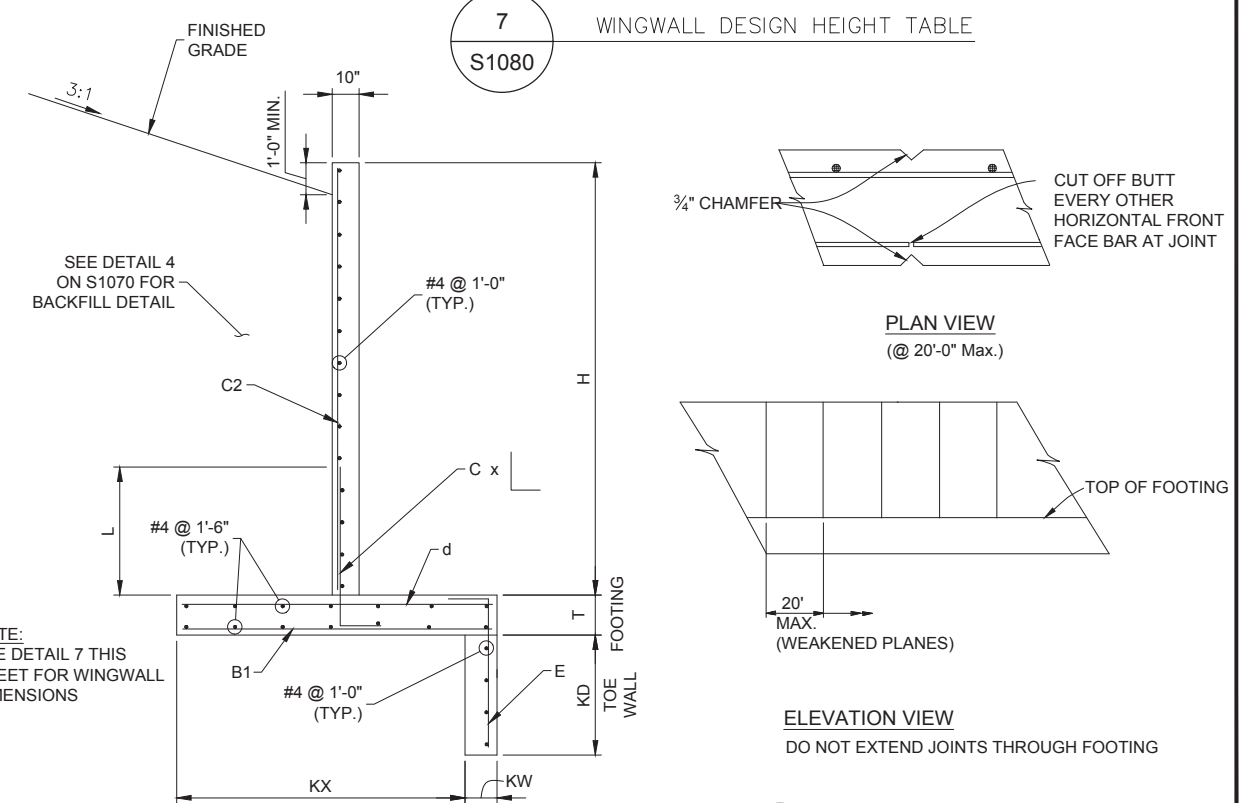

8  
S1080  
WEAKENED PLANE - DETAIL  
SCALE: 1"=1'

X:\00\_KDC\_PROJECTS\K15009\_VIA DIA OnCall\K15009.5 DIW Pond Wall\20 DWG\DIW Pond Wall\_Plan.dwg Nov 21, 2017 - 3:36pm Jang

### PIPING SYMBOLS

### MECHANICAL SYMBOLS

### IDENTIFICATION SYMBOLS

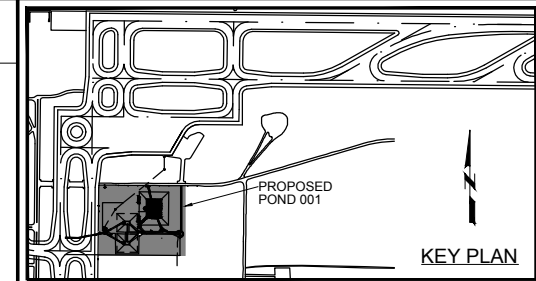

# POND 001 EXPANSION

| DOUBLE LINE | SINGLE LINE | DESCRIPTION                               | DOUBLE LINE | SINGLE LINE | DESCRIPTION                      |
|-------------|-------------|---|-------------|-------------|----------------------------------|
|             |             | WELDED JOINT                              |             |             | GATE VALVE                       |
|             |             | GROOVED END JOINT                         |             |             | KNIFE GATE VALVE                 |
|             |             | FLANGED JOINT                             |             |             | BUTTERFLY VALVE                  |
|             |             | HUB & SPIGOT JOINT (RUBBER GASKET)        |             |             | CHARACTERIZED BALL CONTROL VALVE |
|             |             | PUSH-ON JOINT (RESTRAINED)                |             |             | BALL VALVE                       |
|             |             | ADAPTER SIDE GROOVED END ADAPTER FLANGE   |             |             | GLOBE VALVE                      |
|             |             | FLANGED COUPLING ADAPTER                  |             |             | 3-WAY GLOBE TYPE MIXING VALVE    |
|             |             | FLANGED COUPLING ADAPTER WITH THRUST TIES |             |             | DIAPHRAGM VALVE                  |
|             |             | FLEXIBLE COUPLING                         |             |             | PLUG VALVE                       |
|             |             | FLEXIBLE COUPLING WITH THRUST TIES        |             |             | LUBRICATED PLUG VALVE            |
|             |             | METAL BELLOWS EXP JOINT                   |             |             | ECCENTRIC PLUG VALVE             |
|             |             | ELASTOMER BELLOWS EXP JOINT               |             |             | SWING CHECK VALVE                |
|             |             | FLEXIBLE COUPLING ADAPTER                 |             |             | WAFER CHECK VALVE                |
|             |             | EXPANSION COMPENSATOR                     |             |             | PINCH VALVE                      |
|             |             | ELBOW UP                                  |             |             | BALL CHECK VALVE                 |
|             |             | ELBOW DOWN                                |             |             | DUAL CHECK VALVE                 |
|             |             | TEE UP                                    |             |             | SILENT CHECK VALVE               |
|             |             | TEE DOWN                                  |             |             | MUD VALVE (PLAN VIEW)            |
|             |             | LATERAL UP                                |             |             | NEEDLE VALVE                     |
|             |             | LATERAL DOWN                              |             |             | CHECK BACKFLOW PREVENTER         |
|             |             | CONCENTRIC REDUCER                        |             |             | PIPE MATERIAL CHANGE             |
|             |             | ECCENTRIC REDUCER TF, BF                  |             |             |                                  |
|             |             | UNION                                     |             |             |                                  |
|             |             | CAP                                       |             |             |                                  |
|             |             | ANCHOR                                    |             |             |                                  |
|             |             | ELBOW, 90 DEGREE                          |             |             |                                  |
|             |             | CROSS                                     |             |             |                                  |
|             |             | TEE                                       |             |             |                                  |
|             |             | ELBOW, 45 DEGREE                          |             |             |                                  |
|             |             | ELBOW, 22.5 DEGREE                        |             |             |                                  |
|             |             | ELBOW, 11.25 DEGREE                       |             |             |                                  |
|             |             | LATERAL                                   |             |             |                                  |

| SINGLE LINE | DESCRIPTION  |
|-------------|--|
|             | STRAINER: WYE TYPE WITH BLOWOFF                      |
|             | THERMOMETER  |
|             | VALVE: ANGLE   |
|             | VALVE: AIR RELIEF                                    |
|             | VALVE: BALL  |
|             | VALVE: BALL CHECK                                    |
|             | VALVE: BUTTERFLY                                     |
|             | VALVE: CONE  |
|             | VALVE: DIAPHRAGM                                     |
|             | VALVE: FLAPPER CHECK                                 |
|             | VALVE: FOUR WAY                                      |
|             | VALVE: GATE  |
|             | VALVE: GLOBE   |
|             | VALVE: HOSE  |
|             | VALVE: NEEDLE  |
|             | VALVE: PINCH   |
|             | VALVE: PLUG CONCENTRIC                               |
|             | VALVE: PLUG ECCENTRIC                                |
|             | VALVE: PRESSURE RELIEF                               |
|             | PRESSURE-REDUCING REGULATOR                          |
|             | VALVE: SWING CHECK                                   |
|             | VALVE: TELESCOPING                                   |
|             | VALVE: THREE WAY AIR OPERATED                        |
|             | VALVE: THREE WAY MOTOR OPERATED                      |
|             | VALVE: THREE WAY SOLENOID OPERATED                   |
|             | VALVE: VACUUM  |
|             | BACKPRESSURE REGULATOR SELF-CONTAINED                |
|             | BACKPRESSURE REGULATOR W/ EXTERNAL PRESSURE TAP      |
|             | PRESSURE-REDUCING REGULATOR: SELF-CONTAINED          |
|             | PRESSURE-REDUCING REGULATOR W/ EXTERNAL PRESSURE TAP |

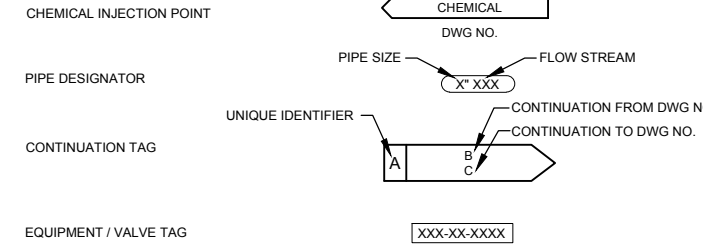

### LINE SYMBOLS

|                                   |  |
|-----------------------------------|--|
| PIPE ABOVE OR BELOW GROUND        |  |
| PIPE UNDERNEATH SLAB OR STRUCTURE |  |
| FUTURE                            |  |
| EXISTING                          |  |
| DEMO                              |  |

### PROCESS LINE SYMBOLS

|                                   |  |
|-----------------------------------|--|
| PRIMARY PROCESS FLOW IN PIPE      |  |
| SECONDARY PROCESS FLOW IN PIPE    |  |
| PRIMARY PROCESS FLOW IN CHANNEL   |  |
| SECONDARY PROCESS FLOW IN CHANNEL |  |

### FLOW STREAM IDENTIFIER

| WTP FLUID CODES |                                     | WWTP FLUID CODES |                                  |
|-----------------|-------------------------------------|------------------|----------------------------------|
| CODE            | DESCRIPTION                         | CODE             | DESCRIPTION                      |
| AML             | AMMONIA LIQUID                      | AIR              | AERATION AIR                     |
| AMG             | AMMONIA GAS                         | AIR              | AEROBIC DIGESTER AIR             |
| AMS             | AMMONIA SOLUTION                    | CD               | CHEMICAL DRAIN                   |
| AMV             | AMMONIA VACUUM                      | CHA              | CHANNEL AIR                      |
| AW              | APPLIED WATER                       | CW               | COLD WATER                       |
| BP              | BYPASS                              | DR               | DRAIN                            |
| CA              | COMPRESSED AIR                      | DSL              | DIGESTED SLUDGE                  |
| CAP             | COAGULANT AID POLYMER               | FE               | FINAL EFFLUENT                   |
| CD              | CHEMICAL DRAIN                      | FM               | FORCE MAIN                       |
| CL              | CHLORINE (GAS OR LIQUID STATE)      | FOR              | FUEL OIL RETURN                  |
| CLS             | CHLORINE SOLUTION                   | FOS              | FUEL OIL SUPPLY                  |
| CLV             | CHLORINE GAS UNDER VACUUM           | FW               | FIRE WATER                       |
| CS              | CAUSTIC SODA                        | FE               | FINAL EFFLUENT                   |
| CSOL            | CHEMICAL SUMP DRAIN LINE            | GR               | GRIT SLURRY                      |
| CV              | CHLORINATOR VENT AND DETECTION LINE | HPA              | HIGH PRESSURE AIR                |
| D               | DRAIN                               | HW               | HOT WATER                        |
| DPD             | DEWATERING PUMP DISCHARGE           | HWR              | HOT WATER RETURN                 |
| EA              | EXHAUST AIR                         | HWS              | HOT WATER SUPPLY                 |
| FAP             | FLOCCULANT AID POLYMER              | HYP              | HYPOCHLORITE SOLUTION            |
| FS              | FERRIC SULFATE                      | ML               | MIXED LIQUOR                     |
| FSP             | FIRE PROTECTION SPRINKLER SYSTEM    | NG               | NATURAL GAS                      |
| FW              | FILTERED WATER                      | NPW              | NON-POTABLE WATER                |
| GCO2            | GASEOUS CARBON DIOXIDE              | OF               | OVERFLOW                         |
| HC              | HYDROCHLORIC ACID                   | POL              | POLYMER                          |
| HF              | HYDROFLUOSILICIC ACID               | PD               | PUMPED DRAINAGE                  |
| HL              | HYDRATED LIME                       | PW               | POTABLE WATER                    |
| HLS             | HYDRATED LIME SOLUTION              | PS               | PUMP STATION                     |
| HP              | HYDROGEN PEROXIDE (UNDILUTED)       | RAS              | RETURN ACTIVATED SLUDGE          |
| HR              | HEATING WATER RETURN                | RI               | RAW INFLUENT                     |
| HS              | HEATING WATER SUPPLY                | RW               | REUSE WATER                      |
| MWR             | MOTOR COOLING WATER RETURN          | SAM              | SAMPLE LINE                      |
| MWS             | MOTOR COOLING WATER SUPPLY          | SSS              | SANITARY SEWER                   |
| OA              | OUTSIDE AIR                         | SEC              | SECONDARY EFFLUENT               |
| OF              | OVERFLOW                            | SEP              | SEPTAGE                          |
| OW              | OZONATED WATER                      | SEP              | SCREENED INFLUENT                |
| PA              | PLANT AIR                           | SD               | STORM DRAIN                      |
| PAC             | POWDERED ACTIVATED CARBON           | TWAS             | THICKENED WASTE ACTIVATED SLUDGE |
| PLS             | POLYMER SOLUTION                    | WAS              | WASTE ACTIVATED SLUDGE           |
| POL             | POLYMER                             |                  |                                  |
| PS              | PHOSPHATE SOLUTION                  |                  |                                  |
| PW              | POTABLE WATER                       |                  |                                  |
| RM              | RAPID MIX WATER                     |                  |                                  |
| RW              | RAW WATER                           |                  |                                  |
| SA              | SAMPLE LINE                         |                  |                                  |
| SD              | STORM DRAIN                         |                  |                                  |
| SL              | SLUDGE                              |                  |                                  |
| SPD             | SUMP PUMP DISCHARGE                 |                  |                                  |
| SS              | SANITARY SEWER                      |                  |                                  |
| TW              | TREATED WATER                       |                  |                                  |
| UW              | UTILITY WATER (NON-POTABLE WATER)   |                  |                                  |
| V               | VACUUM                              |                  |                                  |
| VTR             | VENT THROUGH ROOF                   |                  |                                  |
| WT              | SANITARY SEWER                      |                  |                                  |
| WW              | FILTERED WASH WATER                 |                  |                                  |

|                     |                                   |         |        |     |
|---------------------|-----------------------------------|---------|--------|-----|
| ISSUE RECORD        |                                   |         |        |     |
| NO.                 | BY                                | PURPOSE | DATE   | CKD |
| 1                   | JK                                | IFC     | 21NO17 |     |
| SCALE               | NONE                              |         |        |     |
| DATE                | JUNE, 2017                        |         |        |     |
| DRAWN BY:           | JPC                               |         |        |     |
| CHECKED BY:         | BG                                |         |        |     |
| FAA AIP NO.         |                                   |         |        |     |
| WORK BREAKDOWN NO.  |                                   |         |        |     |
| DESIGN CONTRACT NO. | 201418360                         |         |        |     |
| CONST. CONTRACT NO. | 201418360 TASK 5                  |         |        |     |
| VOLUME NO.          | 1                                 |         |        |     |
| SHEET TITLE         | MECHANICAL LEGEND & ABBREVIATIONS |         |        |     |
| SHEET NO.           | M1000                             |         |        |     |
|                     | 41 OF 61                          |         |        |     |
| CADD FILE NO.       | 10697A1000M1000                   |         |        |     |

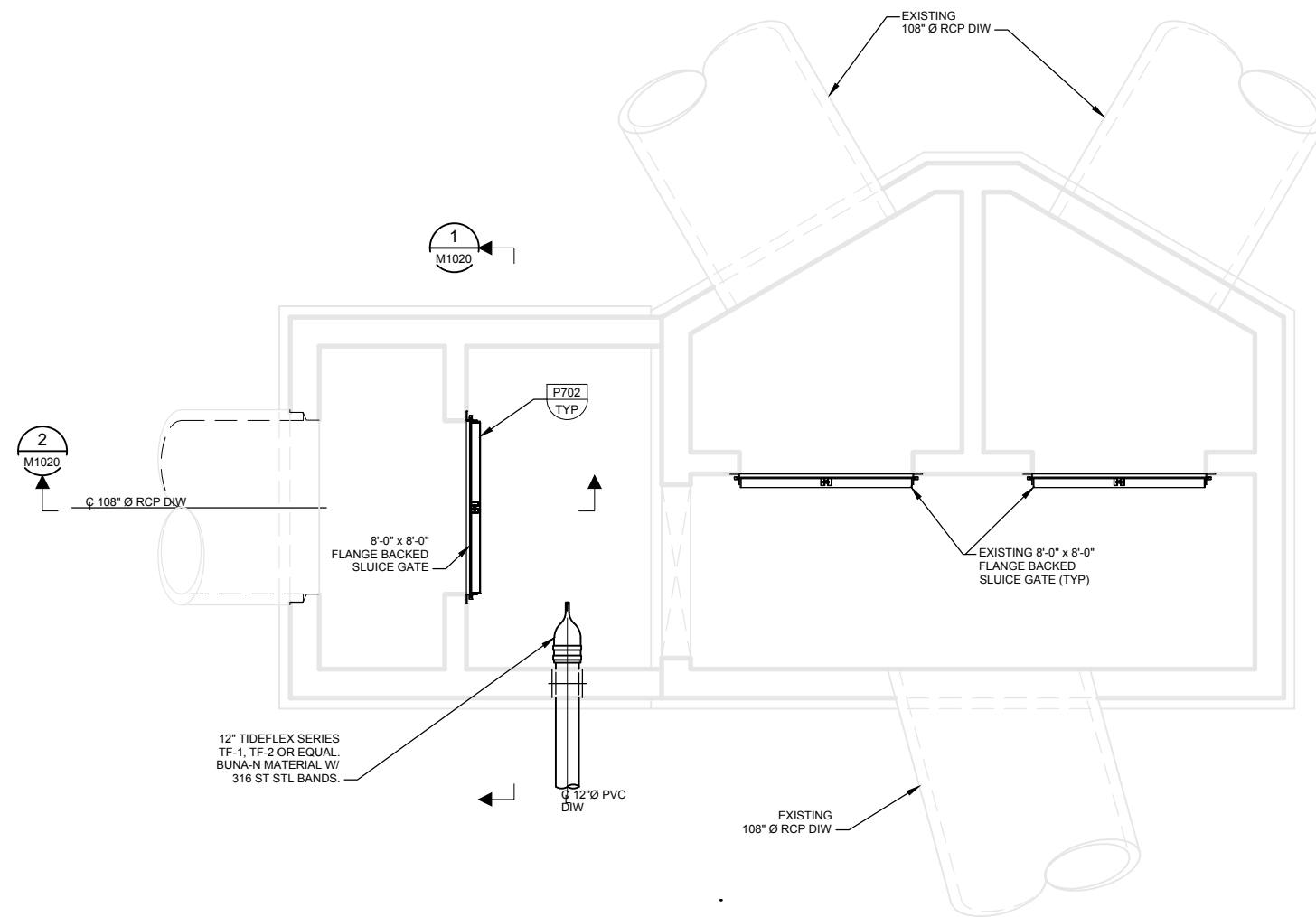

**A** MECHANICAL PLAN  
 SCALE: 1/4" = 1'-0"  
 FILE: 10697A1000M0101

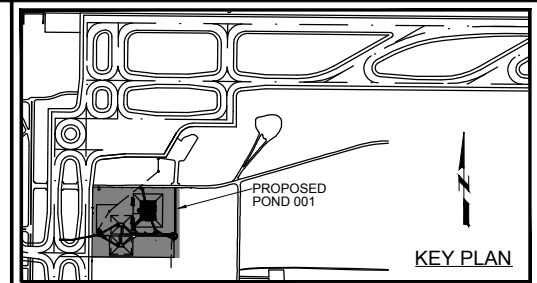

POND 001 EXPANSION

| NO. | BY | PURPOSE | DATE   | CHKD |
|-----|----|---------|--------|------|
| 1   | JK | IFC     | 21NO17 |      |

SCALE AS NOTED

DATE JUNE, 2017

DRAWN BY: JPC

CHECKED BY: BG

FAA AIP NO:

WORK BREAKDOWN NO.

DESIGN CONTRACT NO. 201418360

CONST. CONTRACT NO. 201418360 TASK 5

VOLUME NO. 1

SHEET TITLE  
 DIVERSION  
 STRUCTURE  
 PLAN

SHEET NO.  
 M1010

42 OF 61

CADD FILE NO.  
 10697A1000M1010





POND 001 EXPANSION

| ISSUE RECORD | NO. | BY  | PURPOSE | DATE   | CKD |
|--------------|-----|-----|---------|--------|-----|
| 1            | JK  | IFC |         | 21NO17 |     |

SCALE AS NOTED

DATE JUNE, 2017

DRAWN BY: JPC

CHECKED BY: BG

FAA AIP NO:

WORK BREAKDOWN NO:

DESIGN CONTRACT NO. 201418360

CONST. CONTRACT NO. 201418360 TASK 5

VOLUME NO. 1

SHEET TITLE

DIVERSION  
STRUCTURE  
SECTIONS

SHEET NO. M1020

43 OF 61

CADD FILE NO. 10697A1000M1020

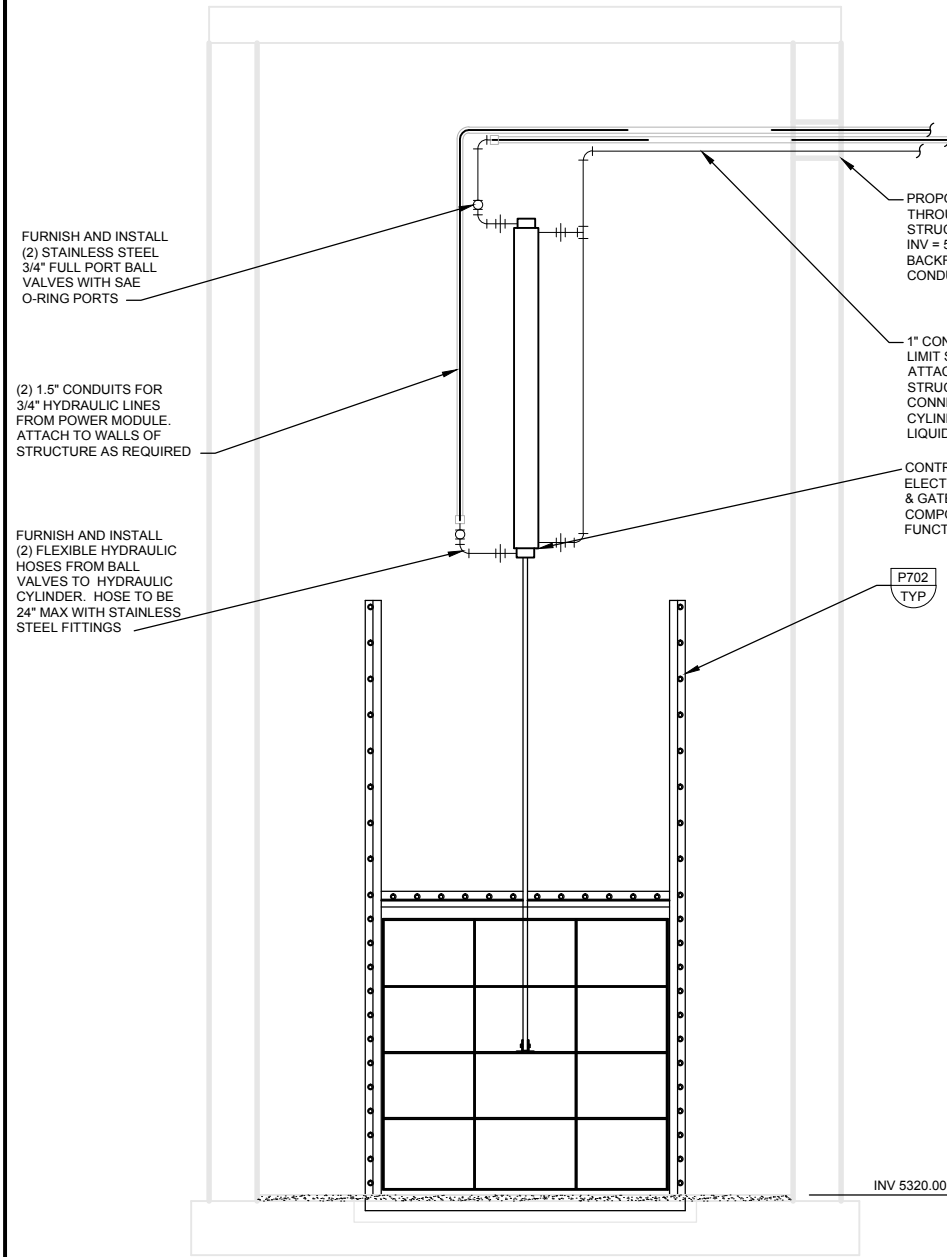
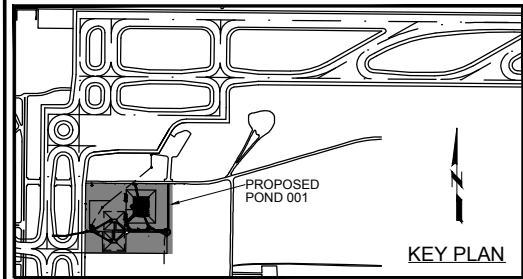

**2 SECTION**  
M1010 SCALE: 3/8" = 1'-0"  
FILE: 10697A1000M0301

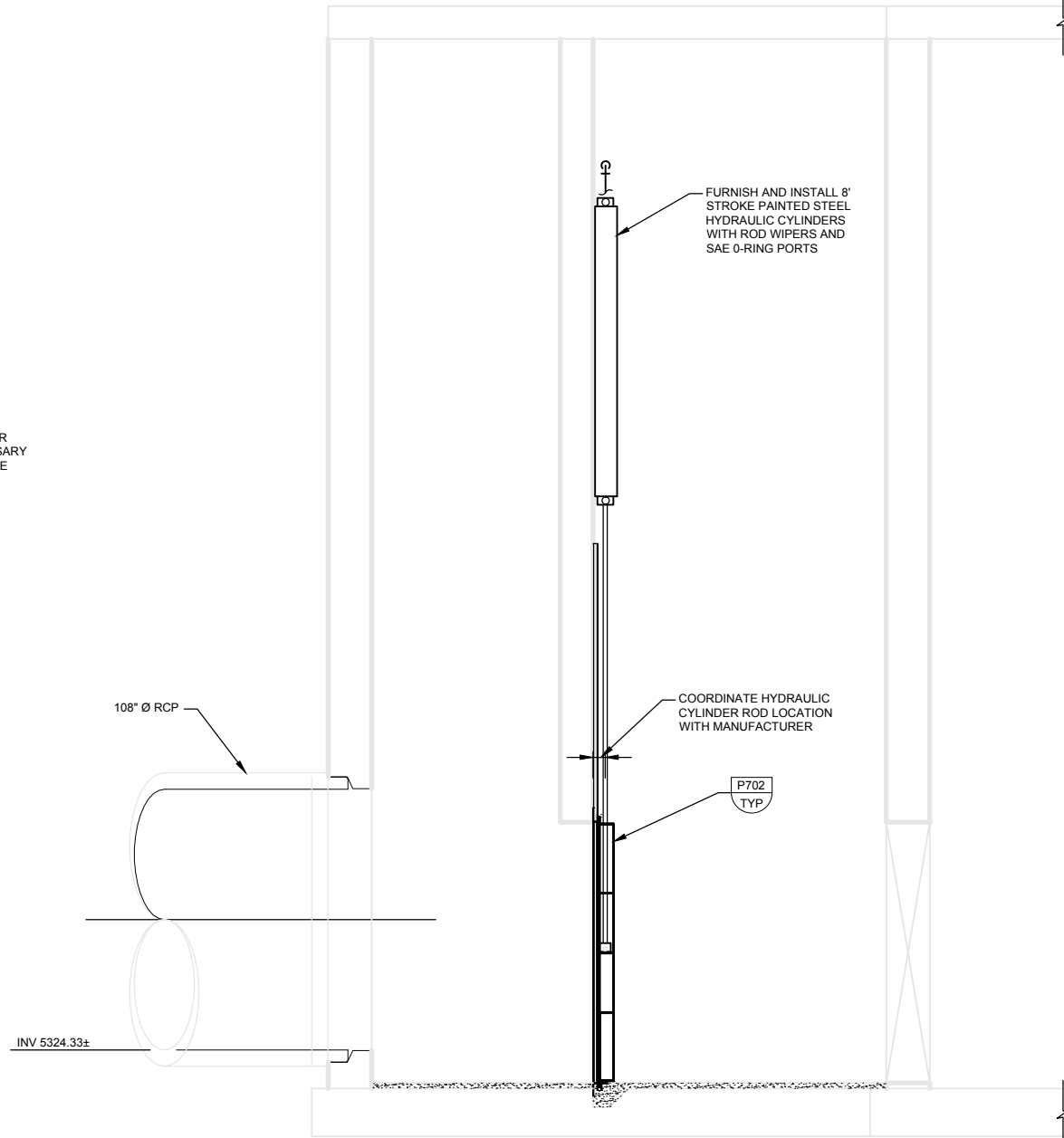

**2 SECTION**  
M1020 SCALE: 3/8" = 1'-0"  
FILE: 10697A1000M0301

C:\CAD\_Support\Transmitted\_DWG\_Files\10697A1000M1020.dwg Nov 20, 2017 - 10:05am borogken



ELECTRICAL PLAN AND ONE-LINE SYMBOLS

IDENTIFICATION SYMBOLS

**EQUIP #** EQUIPMENT AND INSTRUMENT IDENTIFICATION

**EQUIPMENT/INSTRUMENT LOCATOR**

**LUMINAIRE IDENTIFICATION**  
 a = CIRCUIT DESIGNATION  
 b = DEVICE SWITCHED FROM  
 c = MOUNTING HEIGHT IN FEET TO BOTTOM OF FIXTURE

**CONDUIT IDENTIFICATION**  
 XXXX = CONDUIT NUMBER, REFER TO CONDUIT SCHEDULE UNLESS OTHERWISE NOTED, GROUPED CONDUITS ARE LABELED LEFT TO RIGHT OR TOP TO BOTTOM.

**INDICATES KEYNOTE X (PERTAINS ONLY TO SHEET WHERE NOTE IS FOUND)**

**DISCONNECT SWITCH**  
 a = TYPE, REFER TO DISCONNECT SCHEDULE

**GROUNDING**

UNDERGROUND GROUND CABLE #4/0 SDBC UNLESS OTHERWISE NOTED

GROUND ROD

GROUND ROD AND GROUND WELL

GROUND CONNECTION

**LUMINAIRES**

2', 4', OR 8' STRIP

2' X 2' LAY-IN TROFFER

2' X 4' LAY-IN TROFFER

LUMINAIRE POLE MOUNTED

**STROBE**  
 a = COLOR  
 R = RED  
 G = GREEN  
 A = AMBER

LUMINAIRE, EMERGENCY BATTERY-POWERED

LUMINAIRE, EMERGENCY/EXIT BATTERY-POWERED

LUMINAIRE, EMERGENCY BATTERY-POWERED REMOTE

LUMINAIRE, SURFACE OR PENDANT MOUNTED

LUMINAIRE, WALL MOUNTED

LUMINAIRE, FLOOD/SPOT

LUMINAIRE, EXIT ONE OR TWO FACES AS INDICATED. ARROW POINTS IN DIRECTION OF EGRESS.

LUMINAIRE, WALL WASHER

PHOTOCELL

**FIRE ALARM**

**SMOKE DETECTOR**  
 a = TYPE  
 I = IONIZATION  
 P = PHOTOELECTRIC  
 d = DUCT DETECTOR

**FIRE ALARM CONTROL PANEL**

**FIRE ALARM PULL STATION**

**FIRE ALARM HORN/STROBE COMBINATION**

**FIRE ALARM STROBE**

**FIRE SPRINKLER**  
 F = FLOW SWITCH  
 T = TAMPER SWITCH

**SWITCHES/RECEPTACLES**

**SINGLE POLE SWITCH**  
 a = CIRCUIT DESIGNATION  
 b = DEVICE SWITCHED DESIGNATION

**c = TYPE**  
 2 = DOUBLE POLE SWITCH  
 3 = THREE-WAY SWITCH  
 4 = FOUR-WAY SWITCH  
 K = KEY OPERATED SWITCH  
 F = SWITCH AND FUSE/STAT HOLDER  
 P = SWITCH AND PILOT LIGHT  
 T = THERMOSTAT  
 D = DIMMER SWITCH  
 L = LOW VOLTAGE LIGHT SWITCH  
 M = MANUAL MOTOR STARTER

**OCCUPANCY SENSOR**  
 a = CIRCUIT DESIGNATION  
 b = DEVICE SWITCHED DESIGNATION

**SWITCH AND SINGLE RECEPTACLE**  
 a = CIRCUIT DESIGNATION  
 b = DEVICE TYPE DESIGNATION

**DUPLEX RECEPTACLE**  
 a = CIRCUIT DESIGNATION  
 b = DEVICE TYPE DESIGNATION

**QUADRUPLEX RECEPTACLE**  
 a = CIRCUIT DESIGNATION  
 b = DEVICE TYPE DESIGNATION

**IN FLOOR DUPLEX RECEPTACLE**  
 a = CIRCUIT DESIGNATION  
 b = DEVICE TYPE DESIGNATION

**IN FLOOR QUADRUPLEX RECEPTACLE**  
 a = CIRCUIT DESIGNATION  
 b = DEVICE TYPE DESIGNATION

**DUPLEX RECEPTACLE w/SPLIT WIRE**  
 a = CIRCUIT DESIGNATION  
 b = DEVICE TYPE DESIGNATION

**APPLIANCE RECEPTACLE**  
 a = CIRCUIT DESIGNATION  
 b = DEVICE TYPE DESIGNATION

**WELDING RECEPTACLE**  
 a = CIRCUIT DESIGNATION  
 b = DISCONNECT TYPE

**SPECIAL PURPOSE RECEPTACLE**  
 a = CIRCUIT DESIGNATION  
 b = DEVICE TYPE DESIGNATION

**TWIST LOCK RECEPTACLE**  
 a = AMP RATING

**TELEPHONE OUTLET**  
 a = CIRCUIT DESIGNATION  
 b = MOUNTING HEIGHT

**DATA COMMUNICATIONS OUTLET**  
 a = CIRCUIT DESIGNATION  
 b = MOUNTING HEIGHT

**RACEWAY**

EXPOSED CONDUIT

BREAK AND CONTINUATION IN CONDUIT RUN

EXPOSED CONDUIT HIDDEN BEHIND WALLS, FLOORS OR OTHER STRUCTURES

UNDERGROUND CONDUIT, DIRECT BURIED OR IN DUCTBANK

CONDUIT IN SLAB

CONDUIT VERTICAL CHANGE IN DIRECTION

CONDUIT CAP

JUNCTION BOX

CONDUIT SEAL

CONDUIT TEE

DUCTBANK APPROXIMATE DIMENSIONS SHOWN ON DUCTBANK SECTIONS

**CONDUIT SIZE AND CONDUCTORS**

**INDIVIDUAL CONDUCTORS**

W'C-(3-X (Ø), 1-Y (N) & 1-Z (G))

W'C (WHERE INDICATED): W = CONDUIT TRADE SIZE

3-X (Ø):  
 3 = QUANTITY  
 X = SIZE OF CONDUCTORS  
 (Ø) = DESIGNATES PHASE CONDUCTORS

1-Y (N)(WHERE INDICATED):  
 1 = QUANTITY  
 Y = SIZE OF CONDUCTORS  
 (N) = DESIGNATES NEUTRAL CONDUCTORS

1-Z (G)(WHERE INDICATED):  
 1 = QUANTITY  
 Z = SIZE OF CONDUCTORS  
 (G) = DESIGNATES GROUND CONDUCTORS

U(3-X (Ø) & 1-X (G))  
 U = NUMBER OF PARALLEL RUNS

**MULTI CONDUCTOR CABLES**

K/2/C#16S  
 K (WHERE INDICATED) = NUMBER OF PAIRS  
 2/C#16S = TWO CONDUCTOR, 16 GAUGE, TWISTED SHIELDED PAIR

K/3/C#16S  
 K (WHERE INDICATED) = NUMBER OF TRIPLES  
 3/C#16S = THREE CONDUCTOR, 16 GAUGE, TWISTED SHIELDED TRIPLES

N/CX  
 N = NUMBER OF CONDUCTORS IN THE CABLE  
 X = SIZE OF CONDUCTORS

**FIBER OPTIC CABLES**

FO/N  
 N = NUMBER OF INDIVIDUAL FIBERS

**MEDIUM VOLTAGE**

**CIRCUIT BREAKER, MEDIUM VOLTAGE**  
 a = CIRCUIT BREAKER NUMBER  
 b = FRAME SIZE

**ANSI RELAY DEVICE**  
 a = ANSI DEVICE FUNCTION  
 b = QUANTITY

**MEDIUM VOLTAGE DISCONNECT SWITCH NON-FUSED CUT OUT**

**MEDIUM VOLTAGE DISCONNECTING FUSE SINGLE FUSE CUT OUT**

**MEDIUM VOLTAGE DISCONNECTING FUSE DOUBLE FUSE CUT OUT**

**MEDIUM VOLTAGE SINGLE FUSE**

**MEDIUM VOLTAGE DOUBLE FUSE**

**MEDIUM VOLTAGE LIVE FRONT TERMINATOR**

**MEDIUM VOLTAGE ELBOW**

**MEDIUM VOLTAGE TEE**

**MEDIUM VOLTAGE CONTACTOR**

**MEDIUM VOLTAGE STARTER**

**MOV-ELBOW ARRESTER**

**LOW VOLTAGE**

**LOW VOLTAGE CIRCUIT BREAKER**  
 a = TYPE  
 MCP = MOTOR CIRCUIT PROTECTOR  
 TM = THERMAL MAGNETIC  
 SS = SOLID STATE  
 b = FRAME SIZE (MANUFACTURER TO DETERMINE FRAME SIZE UNLESS INDICATED)  
 c = NUMBER OF POLES  
 d = TRIP SETTING (AT = AMP TRIP) (AC = MCP CONTINUOUS RATING)  
 e = DESIGNATION  
 f = INTERRUPTING RATING

**LOW VOLTAGE CIRCUIT BREAKER AUXILIARY OPERATOR**  
 S = SHUNT TRIP  
 G = GROUND FAULT INTERRUPTER  
 V = SOLENOID KEY RELEASE

**DISCONNECT SWITCH**  
 A = TYPE, REFER TO DISCONNECT SCHEDULE

**FUSED DISCONNECT SWITCH**  
 B = TYPE, REFER TO DISCONNECT SCHEDULE  
 b = FUSE RATING

FUSE

**COMBINATION STARTER WITH CONTROL POWER TRANSFORMER**  
 a = CIRCUIT BREAKER DISCONNECT, TYPE AS NOTED  
 b = STARTER TYPE  
 c = NEMA STARTER SIZE  
 d = OVERLOAD

**VARIABLE FREQUENCY DRIVE WITH FEATURES AS SHOWN**  
 a = INPUT CONTACTOR  
 b = OUTPUT CONTACTOR  
 c = BYPASS STARTER  
 d = INPUT CIRCUIT BREAKER

LR = LINE REACTOR  
 LL = LOAD REACTOR

**REDUCED VOLTAGE SOLID STATE STARTER WITH FEATURES AS SHOWN**  
 BS = BYPASS STARTER

EQUIPMENT ENCLOSURE

**MISCELLANEOUS**

**MOTOR**  
 HP = HORSEPOWER RATING  
 FULL LOAD AMPS AS NOTED

**PACKAGED EQUIPMENT**  
 LOAD RATING AS INDICATED  
 a = RATED LOAD  
 b = UNIT(HP, KW, KVA) AS INDICATED

**TRANSFORMER**  
 a = DEVICE I.D.  
 b = KVA RATING  
 c = NUMBER OF PHASES  
 d = PRIMARY VOLTAGE  
 e = SECONDARY VOLTAGE  
 f,g = CONNECTION TYPE SYMBOL  
 h = IMPEDANCE

GROUNDED WYE CONNECTION

DELTA CONNECTION

**ENGINE-GENERATOR RATINGS AS INDICATED ON THE DRAWINGS**  
 a = KVA/KW  
 b = VOLTAGE/CONNECTION  
 c = PHASE  
 d = WIRE  
 e = PF

**CURRENT TRANSFORMER WITH SHORTING TERMINAL BLOCK**  
 a = QUANTITY  
 b = RATIO

**POTENTIAL TRANSFORMER**  
 a = QUANTITY  
 b = RATIO  
 c,d = CONNECTION TYPE SYMBOL

**SOLID STATE MULTIFUNCTION METER**

**AMPERE TEST POINT**

**VOLTAGE TEST POINT**

**UTILITY METER**

**LIGHTNING ARRESTER**

**SURGE PROTECTIVE DEVICE**

**DRAWOUT CONNECTION**

**GROUND**

**CAPACITOR**

**BATTERY**

**KIRK KEY INTERLOCK**

**LOAD BANK**



ISSUE RECORD

| NO. | BY | PURPOSE | DATE   | CHK |
|-----|----|---------|--------|-----|
| 1   | JK | IFC     | 21NO17 |     |

SCALE

DATE JUNE 19, 2017

DRAWN BY: BPR

CHECKED BY:

FAA AIP NO:

WORK BREAKDOWN NO.

DESIGN CONTRACT NO.

201418360

CONST. CONTRACT NO.

201418360 TASK 5

VOLUME NO.

1

SHEET TITLE

ELECTRICAL

LEGEND

SHEET NO.

E1001

45 OF 61

CADD FILE NO.

10697A1000E1001

ABBREVIATIONS

|           |  |         |  |        |  |
|-----------|--|---------|--|--------|--|
| A         | AMP  | J       | JUNCTION BOX                             | TACH   | TACHOMETER                             |
| ABS       | ABSOLUTE                                   |         |  | TB - X | TERMINAL BLOCK - UNIT X                |
| AC        | ALTERNATING CURRENT                        | K       | KEY INTERLOCK                            | TC     | THERMOCOUPLE / TIME CLOCK / TRAY CABLE |
| ACK       | ACKNOWLEDGE                                | KA      | KILOAMP                                  | TD     | TEMPERATURE DETECTOR RELAY             |
| ACTR      | ACTUATOR                                   | KV      | KILOVOLT                                 | TE     | TOTALLY ENCLOSED                       |
| AF        | AMP FRAME                                  | KVA     | KILOVOLT AMPERE                          | TEFC   | TOTALLY ENCLOSED FAN COOLED            |
| AFC       | AUTOMATIC FREQUENCY CONTROL                | KVAR    | KILOVAR (REACTANCE)                      | TENV   | TOTALLY ENCLOSED NON-VENTILATED        |
| AIC       | AMP INTERRUPTING CAPACITY                  | KW      | KILOWATT                                 | TERM   | TERMINAL                               |
| AM        | AMMETER                                    | KWD     | KILOWATT DEMAND                          | TJB    | TERMINAL JUNCTION BOX                  |
| ANN       | ANNUNCIATOR                                | KWH     | KILOWATT HOUR                            | TM     | THERMAL MAGNETIC                       |
| ANT       | ANTENNA                                    |         |  | TP     | TWISTED PAIR                           |
| APU       | AUXILIARY POWER UNIT                       | L       | LONG-TIME                                | TS     | TEMPERATURE SWITCH                     |
| ARM       | ARMORED CABLE                              | L-B     | LINE-BUS                                 | TS1W   | TWO SPEED CONSEQUENT POLE, ONE WINDING |
| AS        | AMMETER SWITCH                             | L-G     | LINE-GROUND                              | TS2W   | TWO SPEED SEPARATE WINDING             |
| ASYM      | ASYMMETRICAL                               | LA      | LIGHTNING ARRESTOR                       | TSTAT  | THERMOSTAT                             |
| AT        | AMP TRIP                                   | LBL     | LABEL                                    |        |  |
| ATO       | AUTOMATIC THROW OVER                       | LC      | LIGHTING CONTACT OR                      | UHF    | ULTRA HIGH FREQUENCY                   |
| ATP       | AMMETER TEST POINT                         | LCP- X  | LOCAL CONTROL PANEL NO. X                | UNG    | UNGROUND                               |
| ATS       | AUTOMATIC TRANSFER SWITCH                  | LL      | LEAD-LAG LOAD REACTOR                    | UPS    | UNINTERRUPTABLE POWER SUPPLY           |
| AUTO XFMR | AUTOMATIC TRANSFORMER                      | LP      | LIGHT POLE                               | UVR    | UNDER VOLTAGE RELAY                    |
| AUX       | AUXILIARY                                  | LP - X  | LIGHTING PANEL NO. X                     |        |  |
| AWG       | AMERICAN WIRE GAGE                         | LTG     | LIGHTING                                 | V      | VOLT                                   |
|           |  | LV      | LOW VOLTAGE                              | VA     | VOLT AMPERE                            |
|           |  | LVL     | LEVEL                                    | VAR    | VARMETER                               |
| B         | BELL                                       |         |  | VCP    | VENDOR CONTROL PANEL                   |
| BAT       | BATTERY                                    | M-X     | MOTOR CONTROLLER NO. X                   | VFD    | VARIABLE FREQUENCY DRIVE               |
| BFG       | BELOW FINISHED GRADE                       | MA      | MILLIAMPERE                              | VHF    | VERY HIGH FREQUENCY                    |
| BHP       | BRAKE HORSEPOWER                           | MCA     | MOTOR CIRCUIT AMPS                       | VM     | VOLTMETER                              |
| BKR       | BREAKER                                    | MCC - X | MOTOR CONTROL CENTER NO. X               | VP     | VAPORPROOF                             |
| BRF       | BELOW RAISED FLOOR                         | MCP     | MOTOR CIRCUIT PROTECTOR                  | VR     | VOLTAGE REGULATOR                      |
|           |  | MH      | MANHOLE / MOUNTING HEIGHT                | VS     | VOLTAGE SWITCH                         |
| C         | CONDUIT / CONTINUOUS LOAD                  | MLO     | MAIN LUGS ONLY                           | VT     | VOLTAGE TRANSFORMER                    |
| CB        | CIRCUIT BREAKER                            | MOD     | MOTOR OPERATED DAMPER                    | VTP    | VOLTAGE TEST POINT                     |
| CCTV      | CLOSED CIRCUIT TELEVISION                  | MOV     | METAL OXIDE VARISTOR                     |        |  |
| CCW       | COUNTER CLOCKWISE                          | MRP     | MOTOR PROTECTION RELAY                   | W      | WATT / WEST                            |
| CKT       | CIRCUIT                                    | MS-X    | MOTOR STARTER NO. X                      | WT     | WATER TIGHT                            |
| COAX      | COAXIAL CABLE                              | MSP     | MOTOR STARTING PANEL                     | WP     | WEATHER PROOF                          |
| COM       | COMMON                                     | MTO     | MANUAL THROW OVER                        |        |  |
| COMM      | COMMUNICATION                              | MTR-X   | MOTOR NO. X                              | XFMR   | TRANSFORMER                            |
| CPT       | CONTROL POWER TRANSFORMER                  | MTS     | MANUAL TRANSFER SWITCH                   |        |  |
| CS        | CONTROL SWITCH                             | MV      | MEGAVOLT                                 |        |  |
| CT        | CURRENT TRANSFORMER                        | MVA     | MEGAVOLT-AMPERES                         |        |  |
| CV        | CONTROL VALVE                              | MVS     | MEDIUM VOLTAGE SWITCH                    |        |  |
| CW        | CLOCKWISE / COOL WHITE                     | MW      | MEGAWATT                                 |        |  |
|           |  | N       | NEUTRAL                                  |        |  |
| DC        | DIRECT CURRENT                             | NC      | NORMALLY CLOSED                          |        |  |
| DCS       | DISTRIBUTED CONTROL SYSTEM                 | NEC     | NATIONAL ELECTRICAL CODE                 |        |  |
| DCU - X   | DISTRIBUTED CONTROL UNIT NO. X             | NFC     | NONMETALLIC FLEXIBLE CONDUIT             |        |  |
| DEMO      | DEMOLITION                                 | NL      | NIGHT LIGHT                              |        |  |
| DISC      | DISCONNECT SWITCH                          | NO      | NORMALLY OPEN                            |        |  |
| DMI       | DEMAND METER                               | NP      | NAMEPLATE                                |        |  |
| DPDT      | DOUBLE POLE DOUBLE THROW                   |         |  |        |  |
| DPST      | DOUBLE POLE SINGLE THROW                   | O       | OPEN OR OPENED                           |        |  |
| DS        | DOOR SWITCH                                | OH      | OVERHEAD                                 |        |  |
|           |  | OL      | OVERLOAD RELAY                           |        |  |
| E/G       | EMERGENCY GENERATOR                        | P       | POLE                                     |        |  |
| EM        | EMERGENCY                                  | PA      | PUBLIC ADDRESS                           |        |  |
| EMT       | ELECTRICAL METALLIC TUBING                 | PB      | PUSHBUTTON / PULL BOX                    |        |  |
| ENCL      | ENCLOSURE                                  | PCS     | PVC COATED GALVANIZED STEEL CONDUIT      |        |  |
| ENG       | ENGINE                                     | PCM     | PROCESS CONTROL MODULE                   |        |  |
| ENT       | ELECTRICAL NON-METALLIC TUBING             | PE      | PHOTOCELL                                |        |  |
| EP        | EXPLOSION PROOF                            | PF      | POWER FACTOR                             |        |  |
| ETM       | ELAPSED TIME METER                         | PFCC    | POWER FACTOR CORRECTION CAPACITOR        |        |  |
|           |  | PFR     | PHASE FAILURE RELAY                      |        |  |
| FA        | FIRE ALARM                                 | PH      | PHASE                                    |        |  |
| FACP      | FIRE ALARM CONTROL PANEL                   | PNL     | PANEL                                    |        |  |
| FDR       | FEEDER                                     | PPX     | POWER PANEL NO. X                        |        |  |
| FLA       | FULL LOAD AMPS                             | PRI     | PRIMARY                                  |        |  |
| FLX       | FLEXIBLE CONDUIT                           | PT      | POTENTIAL TRANSFORMER                    |        |  |
| FO        | FIBER OPTIC                                | PVC     | POLYVINYL CHLORIDE RIGID PLASTIC CONDUIT |        |  |
| FRC       | FIBERGLASS RIGID CONDUIT                   | PWR     | POWER                                    |        |  |
| FREQ      | FREQUENCY                                  | RAC     | RIGID ALUMINUM CONDUIT                   |        |  |
| FU        | FUSE                                       | RECPT   | RECEPTACLE                               |        |  |
| FU        | SW FUSED SWITCH                            | REV     | REVERSE                                  |        |  |
| FVNR      | FULL VOLTAGE NON-REVERSING                 | RF      | RADIO FREQUENCY                          |        |  |
| FVR       | FULL VOLTAGE REVERSING                     | RMS     | ROOT MEAN SQUARED                        |        |  |
| FWD       | FORWARD                                    | RVAT    | REDUCED VOLTAGE AUTO TRANSFORMER         |        |  |
|           |  | RVNR    | REDUCED VOLTAGE NON-REVERSING            |        |  |
|           |  | RVSS    | REDUCED VOLTAGE SOLID STATE              |        |  |
| G         | GROUND / EQUIPMENT GROUND / GROUND         | S       | SHIELD / SHORT-TIME                      |        |  |
|           |  | SA      | SURGE ARRESTER                           |        |  |
|           |  | SC      | SHORT CIRCUIT                            |        |  |
| GEN       | GENERATOR                                  | SDBC    | SOFT DRAWN BARE COPPER                   |        |  |
| GRC       | GALVANIZED STEEL RIGID CONDUIT             | SFL     | SUB FEED LUGS                            |        |  |
| GFCI      | GROUND FAULT CIRCUIT INTERRUPTER (BREAKER) | SLT     | SEALTIGHT LIQUIDTIGHT FLEXIBLE CONDUIT   |        |  |
|           |  | SM      | SURFACE MOUNTED                          |        |  |
|           |  | SP      | SINGLE POLE                              |        |  |
| GFI       | GROUND FAULT INTERRUPTER (BREAKER)         | SPD     | SURGE PROTECTIVE DEVICE                  |        |  |
| GFR       | GROUND FAULT RELAY                         | SPDT    | SINGLE POLE DOUBLE THROW                 |        |  |
|           |  | SPST    | SINGLE POLE SINGLE THROW                 |        |  |
|           |  | SPKR    | SPEAKER                                  |        |  |
|           |  | SS      | SOLID STATE                              |        |  |
|           |  | STB     | SHORTING TERMINAL BLOCK                  |        |  |
| H         | HOT-LEG                                    | SW      | SWITCH                                   |        |  |
| HF        | HIGH FREQUENCY                             | SWBD    | SWITCHBOARD                              |        |  |
| HP        | HORSEPOWER                                 | SWGR    | SWITCHGEAR                               |        |  |
| HPS       | HIGH PRESSURE SODIUM                       | SYM     | SYMMETRICAL                              |        |  |
| HR        | HOUR                                       |         |  |        |  |
| HSTAT     | HUMIDISTAT                                 |         |  |        |  |
| HV        | HIGH VOLTAGE                               |         |  |        |  |
| HVAC      | HEATING/VENTILATION/AIR CONDITIONING       |         |  |        |  |
| HZ        | HERTZ                                      |         |  |        |  |
|           |  |         |  |        |  |
| I         | INSTANTANEOUS LOAD                         |         |  |        |  |
| IC        | INTERRUPTING CAPACITY                      |         |  |        |  |
| IJB       | INSTRUMENT JUNCTION BOX                    |         |  |        |  |
| IMC       | INTERMEDIATE METAL CONDUIT                 |         |  |        |  |
| INST      | INSTANTANEOUS                              |         |  |        |  |
| INT       | INTERLOCK                                  |         |  |        |  |
| INTERCOM  | INTERCOMMUNICATION                         |         |  |        |  |

POWER DEVICE FUNCTION NUMBERS

|     |  |    |   |
|-----|--|----|---|
| 1   | MASTER ELEMENT                                       | 83 | AUTOMATIC SELECTIVE CONTROL OR TRANSFER RELAY     |
| 2   | TIME-DELAY STARTING OR CLOSING RELAY                 | 84 | OPERATING MECHANISM                               |
| 3   | CHECKING OR INTERLOCKING RELAY                       | 85 | PILOT COMMUNICATIONS, CARRIER OR PILOT-WIRE RELAY |
| 4   | MASTER CONTACTOR                                     | 86 | LOCKOUT RELAY                                     |
| 5   | STOPPING DEVICE                                      | 87 | DIFFERENTIAL PROTECTIVE RELAY                     |
| 6   | STARTING CIRCUIT BREAKER                             | 88 | AUXILIARY MOTOR OR MOTOR GENERATOR                |
| 7   | ANODE CIRCUIT BREAKER                                | 89 | LINE SWITCH                                       |
| 8   | CONTROL POWER DISCONNECTING DEVICE                   | 90 | REGULATING DEVICE                                 |
| 9   | REVERSING DEVICE                                     | 91 | VOLTAGE DIRECTIONAL RELAY                         |
| 10  | UNIT SEQUENCE SWITCH                                 | 92 | VOLTAGE AND POWER DIRECTIONAL RELAY               |
| 11  | MULTIFUNCTION DEVICE                                 | 93 | FIELD-CHANGING CONTACTOR                          |
| 12  | OVER-SPEED DEVICE                                    | 94 | TRIPPING OR TRIP-FREE RELAY                       |
| 13  | SYNCHRONOUS-SPEED DEVICE                             |    |   |
| 14  | UNDER-SPEED DEVICE                                   |    |   |
| 15  | SPEED OR FREQUENCY MATCHING DEVICE                   |    |   |
| 16  | DATA COMMUNICATIONS DEVICE                           |    |   |
| 17  | SHUNTING OR DISCHARGE SWITCH                         |    |   |
| 18  | ACCELERATING OR DECELERATING DEVICE                  |    |   |
| 19  | STARTING-TO-RUNNING TRANSITION CONTACTOR             |    |   |
| 20  | ELECTRICALLY OPERATED VALVE                          |    |   |
| 21  | DISTANCE RELAY                                       |    |   |
| 22  | EQUALIZER CIRCUIT BREAKER                            |    |   |
| 23  | TEMPERATURE CONTROL DEVICE                           |    |   |
| 24  | VOLTS PER HERTZ RELAY                                |    |   |
| 25  | SYNCHRONIZING OR SYNCHRONISM-CHECK DEVICE            |    |   |
| 26  | APPARATUS THERMAL DEVICE                             |    |   |
| 27  | UNDERVOLTAGE RELAY                                   |    |   |
| 27N | GROUND FAULT UNDERVOLTAGE RELAY                      |    |   |
| 28  | FLAME DETECTOR                                       |    |   |
| 29  | ISOLATING CONTACTOR                                  |    |   |
| 30  | ANNUNCIATOR RELAY                                    |    |   |
| 31  | SEPARATE EXCITATION DEVICE                           |    |   |
| 32  | DIRECTIONAL POWER RELAY                              |    |   |
| 33  | POSITION SWITCH                                      |    |   |
| 34  | MASTER SEQUENCE DEVICE                               |    |   |
| 35  | BRUSH-OPERATING OR SLIP-RING SHORT-CIRCUITING DEVICE |    |   |
| 36  | POLARITY DEVICE                                      |    |   |
| 37  | UNDERCURRENT OR UNDERPOWER RELAY                     |    |   |
| 38  | BEARING PROTECTIVE DEVICE                            |    |   |
| 39  | MECHANICAL CONDITION MONITOR                         |    |   |
| 40  | FIELD RELAY  |    |   |
| 41  | FIELD CIRCUIT BREAKER                                |    |   |
| 42  | RUNNING CIRCUIT BREAKER                              |    |   |
| 43  | MANUAL TRANSFER OR SELECTOR DEVICE                   |    |   |
| 44  | UNIT SEQUENCE STARTING RELAY                         |    |   |
| 45  | ABNORMAL ATMOSPHERIC CONDITION MONITOR               |    |   |
| 46  | REVERSE-PHASE OR BALANCE CURRENT RELAY               |    |   |
| 47  | PHASE-BALANCE OR PHASE-SEQUENCE VOLTAGE RELAY        |    |   |
| 48  | INCOMPLETE SEQUENCE RELAY                            |    |   |
| 49  | MACHINE OR TRANSFORMER THERMAL RELAY                 |    |   |
| 50  | INSTANTANEOUS OVERCURRENT RELAY                      |    |   |
| 51  | AC TIME OVERCURRENT RELAY                            |    |   |
| 52  | AC CIRCUIT BREAKER                                   |    |   |
| 53  | FIELD EXCITATION RELAY                               |    |   |
| 54  | TURNING GEAR ENGAGING DEVICE                         |    |   |
| 55  | POWER FACTOR RELAY                                   |    |   |
| 56  | FIELD APPLICATION RELAY                              |    |   |
| 57  | SHORT-CIRCUITING OR GROUNDING DEVICE                 |    |   |
| 58  | RECTIFICATION FAILURE RELAY                          |    |   |
| 59  | OVERVOLTAGE RELAY                                    |    |   |
| 60  | VOLTAGE OR CURRENT BALANCE RELAY                     |    |   |
| 61  | DENSITY SWITCH OR SENSOR                             |    |   |
| 62  | TIME-DELAY STOPPING OR OPENING RELAY                 |    |   |
| 63  | PRESSURE SWITCH                                      |    |   |
| 64  | GROUND DETECTOR RELAY                                |    |   |
| 65  | GOVERNOR   |    |   |
| 66  | NOTCHING OR JOGGING DEVICE                           |    |   |
| 67  | AC DIRECTIONAL OVERCURRENT RELAY                     |    |   |
| 68  | BLOCKING OR OUT OF STEP RELAY                        |    |   |
| 69  | PERMISSIVE CONTROL DEVICE                            |    |   |
| 70  | RHEOSTAT   |    |   |
| 71  | LIQUID LEVEL SWITCH                                  |    |   |
| 72  | DC CIRCUIT BREAKER                                   |    |   |
| 73  | LOAD-RESISTOR CONTACTOR                              |    |   |
| 74  | ALARM RELAY  |    |   |
| 75  | POSITION CHANGING MECHANISM                          |    |   |
| 76  | DC OVERCURRENT RELAY                                 |    |   |
| 77  | TELEMETERING DEVICE                                  |    |   |
| 78  | PHASE-ANGLE MEASURING RELAY                          |    |   |
| 79  | AC RECLOSING RELAY                                   |    |   |
| 80  | FLOW SWITCH  |    |   |
| 81  | FREQUENCY RELAY                                      |    |   |
| 82  | DC LOAD MEASURING RECLOSING RELAY                    |    |   |

COMMONLY USED SUFFIX LETTERS APPLIED TO POWER DEVICE FUNCTION NUMBERS

|    |  |
|----|--|
| A  | ALARM ONLY   |
| B  | BUS PROTECTION   |
| G  | GROUND FAULT PROTECTION  |
|    | (RELAY CT IN A SYSTEM NEUTRAL CIRCUIT OR GENERATOR PROTECTION) |
| GS | GROUND FAULT PROTECTION  |
|    | (RELAY CT IN TOROIDAL OR GROUND SENSOR TYPE)                   |
| L  | LINE PROTECTION  |
| M  | MOTOR PROTECTION   |
| N  | GROUND FAULT PROTECTION  |
|    | (RELAY COIL CONNECTED IN RESIDUAL CT CIRCUIT)                  |
| T  | TRANSFORMER PROTECTION   |
| V  | VOLTAGE  |
| P  | PHASE PROTECTION   |

ABBREVIATIONS

|     |  |
|-----|--|
| AFD | - ARC FLASH DETECTOR                         |
| CLK | - CLOCK OR TIMING SOURCE                     |
| DDR | - DYNAMIC DISTURBANCE RECORDER               |
| DFR | - DIGITAL FAULT RECORDER                     |
| ENV | - ENVIRONMENTAL DATA                         |
| HIZ | - HIGH IMPEDANCE FAULT DETECTOR              |
| HMI | - HUMAN MACHINE INTERFACE                    |
| HST | - HISTORIAN                                  |
| LGC | - SCHEME LOGIC                               |
| MET | - SUBSTATION METERING                        |
| PDC | - PHASOR DATA CONCENTRATOR                   |
| PMU | - PHASOR MEASUREMENT UNIT                    |
| PQM | - POWER QUALITY MONITOR                      |
| RIO | - REMOTE I/O DEVICE                          |
| RTU | - REMOTE TELEMETRY UNIT/REMOTE TERMINAL UNIT |
| SER | - SEQUENCE OF EVENTS RECORDER                |
| TCM | - TRIP CIRCUIT MONITOR                       |

NOTES:

1. REFER TO SPECIFICATIONS AND OTHER DRAWINGS FOR ADDITIONAL ABBREVIATIONS.

CITY & COUNTY  
of DENVER

DENVER  
INTERNATIONAL  
AIRPORT



POND 001 EXPANSION

ISSUE RECORD

NO. BY PURPOSE DATE CKD

1 JK IFC 21NO17

SCALE

DATE JUNE 19, 2017

DRAWN BY: BPR

CHECKED BY:

FAA AIP NO:

WORK BREAKDOWN NO.

DESIGN CONTRACT NO.

201418360

CONST. CONTRACT NO.

201418360 TASK 5

VOLUME NO.

1

SHEET TITLE

ELECTRICAL  
ABBREVIATIONS

SHEET NO.

E1010

46 OF 61

CADD FILE NO.

10697A1000E1010



POND 001 EXPANSION

ISSUE RECORD

NO. BY PURPOSE DATE CKD

1 JK IFC 21NO17

SCALE

DATE JUNE 19, 2017

DRAWN BY: LP

CHECKED BY:

FAA AIP NO:

WORK BREAKDOWN NO.

DESIGN CONTRACT NO.

201418360

CONST. CONTRACT NO.

201418360 TASK 5

VOLUME NO.

1

SHEET TITLE  
ELECTRICAL  
TYPICAL  
DETAILS - I

SHEET NO.

E1016

47 OF 61

CADD FILE NO.

10697A1000E1016

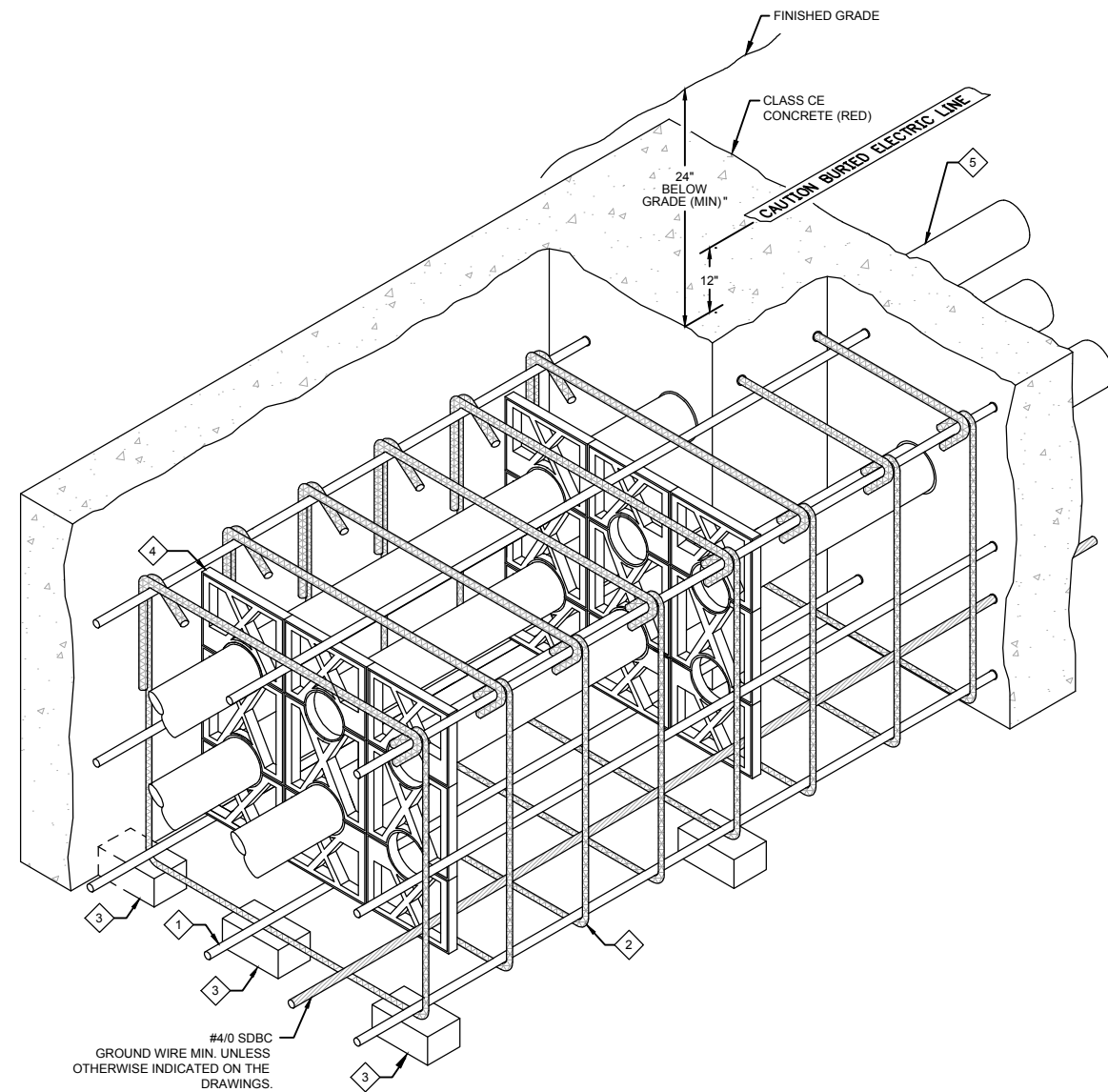

NOTES:

1. DIMENSIONS SHOWN ARE MINIMUM.
2. ADJUST SIZE OF DUCT BANK BASED UPON THESE GUIDELINES AND THE DUCT BANK SPECIFICATION TO ACCOMMODATE ACTUAL NUMBER OF CONDUITS WITHIN DUCT BANK. REFER TO DUCT BANK SECTIONS, AND CONDUIT SCHEDULE FOR NUMBER AND SIZE OF CONDUITS.
3. MAKE PROVISIONS TO PREVENT CONDUIT FLOTATION DURING CONCRETE PLACEMENT & CURING.

KEY NOTES:

- 1 #4 REINFORCING STEEL 12" MAXIMUM ON CENTER AROUND ENTIRE PERIMETER OF DUCT BANK.
- 2 #4 REINFORCING STEEL STIRRUPS MAXIMUM 24" ON CENTER ALONG LENGTH OF DUCT BANK.
- 3 MINIMUM OF TWO PRECAST CONCRETE BAR SUPPORTS PLACED UNDER A STIRRUP AT EACH PVC CONDUIT SPACER ALONG LENGTH OF DUCT BANK. PROVIDE PRECAST BAR SUPPORTS AT INTERVALS OF 24" TO REDUCE DEFLECTION.
- 4 PVC CONDUIT SPACERS ON 8'-0" CENTERS (MAXIMUM) LOCATE 12" FROM STIRRUPS.
- 5 REFER TO DUCT BANK SECTIONS AND CONDUIT SCHEDULES FOR CONDUIT REQUIREMENTS.

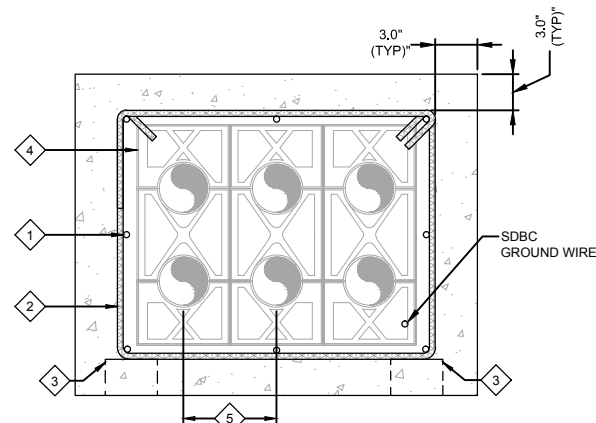

EM001 REINFORCED CONCRETE DUCT BANK

TYP S

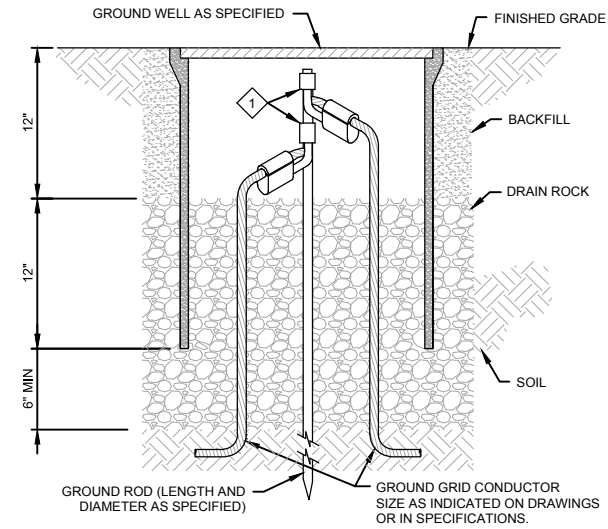

KEY NOTES:

- 1 GROUND ROD TO GROUND GRID CROSS CONNECTOR. SIZE FOR ROD AND CABLE PER CONNECTOR MANUFACTURERS GUIDELINES.

EG001 GROUND ROD AND GROUNDWELL  
TYP COMPRESSION CONNECTION

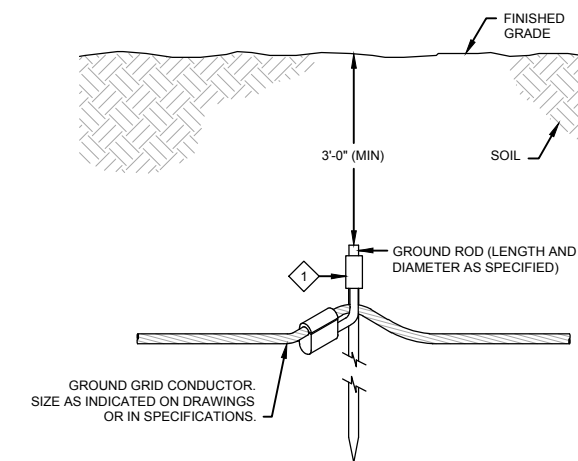

KEY NOTES:

- 1 GROUND ROD TO GROUND GRID CROSS CONNECTOR. SIZE FOR ROD AND CABLE PER CONNECTOR MANUFACTURERS GUIDELINES.

EG002 GROUND ROD  
TYP COMPRESSION CONNECTION



ISSUE RECORD

NO. BY PURPOSE DATE CKD

1 JK IFC 21NO17

SCALE

DATE JUNE 19, 2017

DRAWN BY: LP

CHECKED BY:

FAA AIP NO:

WORK BREAKDOWN NO:

DESIGN CONTRACT NO:

201418360

CONST. CONTRACT NO:

201418360 TASK 5

VOLUME NO:

1

SHEET TITLE

ELECTRICAL  
TYPICAL  
DETAILS - II

SHEET NO.

E1017

48 OF 61

CADD FILE NO.

10697A1000E1017

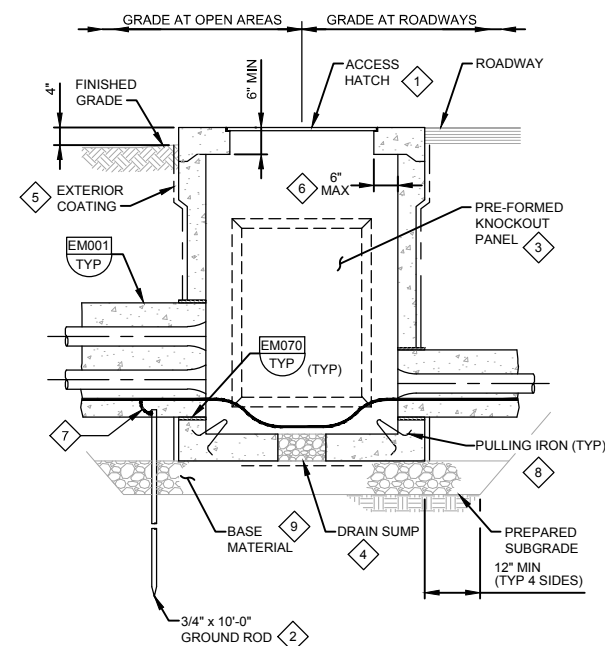

EM056 ELECTRICAL HANDHOLE  
TYP PRECAST CONCRETE W/HATCH

NOTES:

1. PROVIDE MINIMUM INTERIOR DIMENSIONS AS SHOWN IN THE ELECTRICAL HANDHOLE AND MANHOLE SCHEDULE (MAXIMUM INTERIOR DIMENSIONS: 48" WIDE x 48" LONG x 48" DEEP)
2. BOND ALL METALLIC ITEMS INSIDE HANDHOLE TO GROUND ROD USING #4 AWG BARE COPPER CABLE.
3. SEE DRAWINGS FOR ORIENTATION, NUMBER, AND SIZE OF DUCT BANKS AT EACH HANDHOLE.

KEY NOTES:

- 1 SEE THE MANHOLE AND HANDHOLE SCHEDULE FOR REQUIRED LOAD RATING OF HATCH.
- 2 BOND DUCT BANK GROUND CABLE TO GROUND ROD. REFER TO THE SPECIFICATIONS FOR CONNECTION REQUIREMENTS.
- 3 INSTALL DUCT BANKS ONLY THROUGH CAST-IN OPENINGS OR PREFORMED KNOCKOUT PANELS. PROVIDE KNOCKOUTS ON EACH WALL AROUND HANDHOLE.
- 4 PROVIDE MINIMUM 4 INCH DIAMETER, GRAVEL FILLED PENETRATION THROUGH FLOOR OF HANDHOLE. SET SUMP OPENING OVER MINIMUM 18" SQUARE FILTER FABRIC TO ISOLATE GRAVEL FROM BASE MATERIAL BELOW.
- 5 COAT EXTERIOR WALLS BELOW GRADE WITH BITUMINOUS DAMPROOFING.
- 6 MAXIMUM TOP SLAB OVERHANG IS TYPICAL AROUND 4 SIDES OF HANDHOLE.
- 7 GROUNDING CABLE CONNECTION. REFER TO THE SPECIFICATIONS FOR CONNECTION REQUIREMENTS.
- 8 PROVIDE ONE PULLING IRON ON EACH WALL OF HANDHOLE.
- 9 BASE MATERIAL: PROVIDE MIN 12" COMPACTED AGGREGATE BASE COURSE.

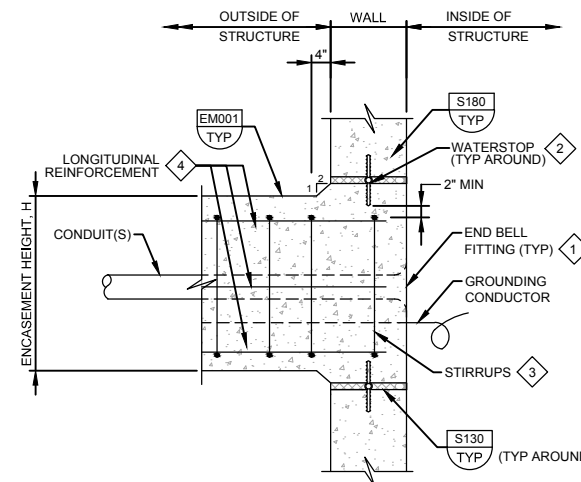

KEY NOTES:

- 1 PROVIDE GROUNDING FITTING FOR METALLIC CONDUITS ENTERING MANHOLE. BOND GROUNDING FITTING TO DUCTBANK GROUNDING CONDUCTOR.
- 2 6" PVC CENTERBULB WATERSTOP TYPICAL AROUND PERIMETER OF ENCASEMENT.
- 3 FOR FIRST 12'-0" FROM INSIDE FACE OF STRUCTURE, STIRRUP SPACING, IN INCHES = (H-4)/2, WHERE H = CONCRETE ENCASEMENT HEIGHT IN INCHES.
- 4 ADDITIONAL #4 x 12'-0" @ 12" ON ALL FOUR FACES OF ENCASEMENT. ALTERNATE WITH TYPICAL REINFORCEMENT FOR 6" SPACING.

EM071 ENCASED CONDUITS AT MANHOLES OR  
TYP STRUCTURES - WITH WATERSTOP

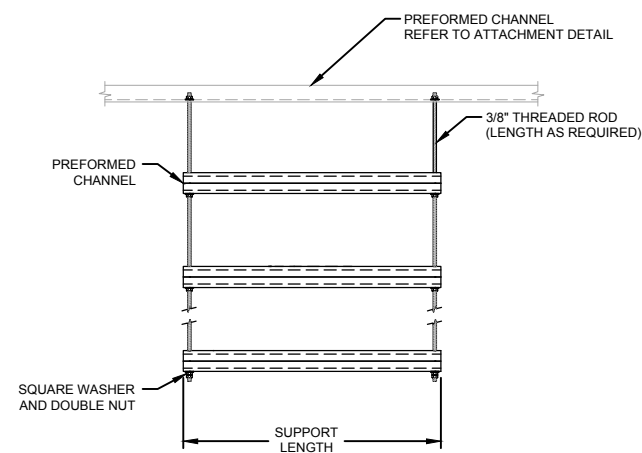

NOTES:

1. PROVIDE NUMBER AND LENGTH OF PREFORMED CHANNEL SUPPORTS AS REQUIRED BY EQUIPMENT AND MATERIALS TO BE INSTALLED.
2. PROVIDE SEISMIC BRACING PER THE SPECIFICATIONS.
3. REFER TO SPECIFICATIONS FOR MATERIAL REQUIREMENTS.

EM102 TRAPEZE SUPPORT  
TYP

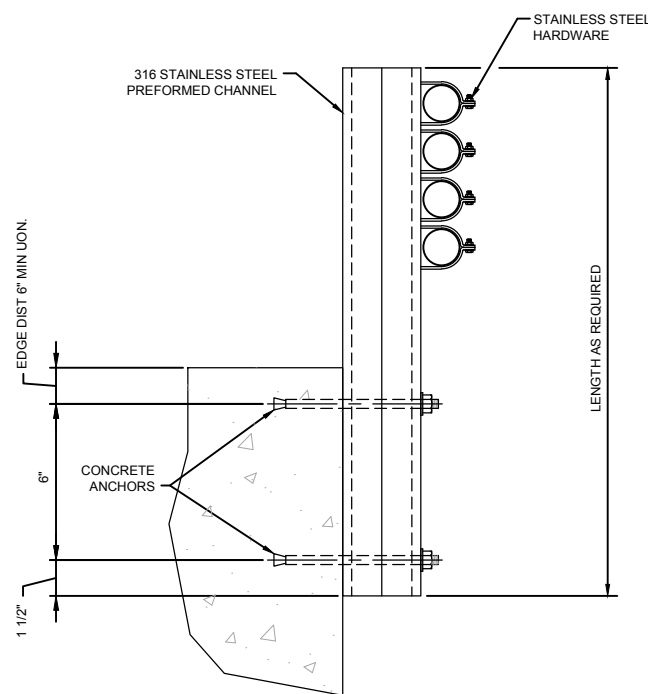

EM103 CONDUIT SUPPORT  
TYP

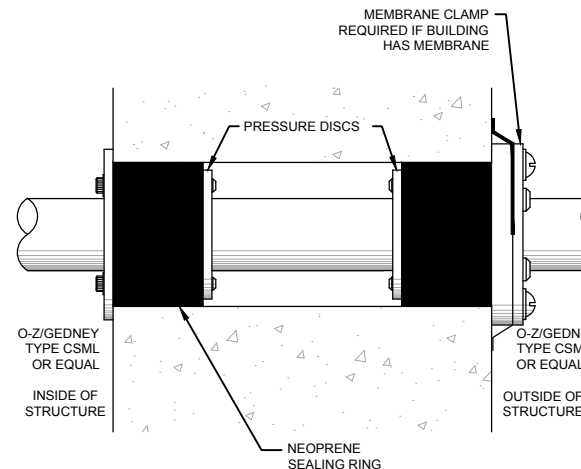

NOTES:

1. REFER TO SPECIFICATIONS FOR CORE-DRILLING REQUIREMENTS.

EM133 CONDUIT WALL PENETRATION  
TYP BELOW GRADE

C:\CAD\_Support\Transmitted\_DWG\_Files\10697A\1000E\1000.dwg Nov 20, 2017 - 9:18am droopken

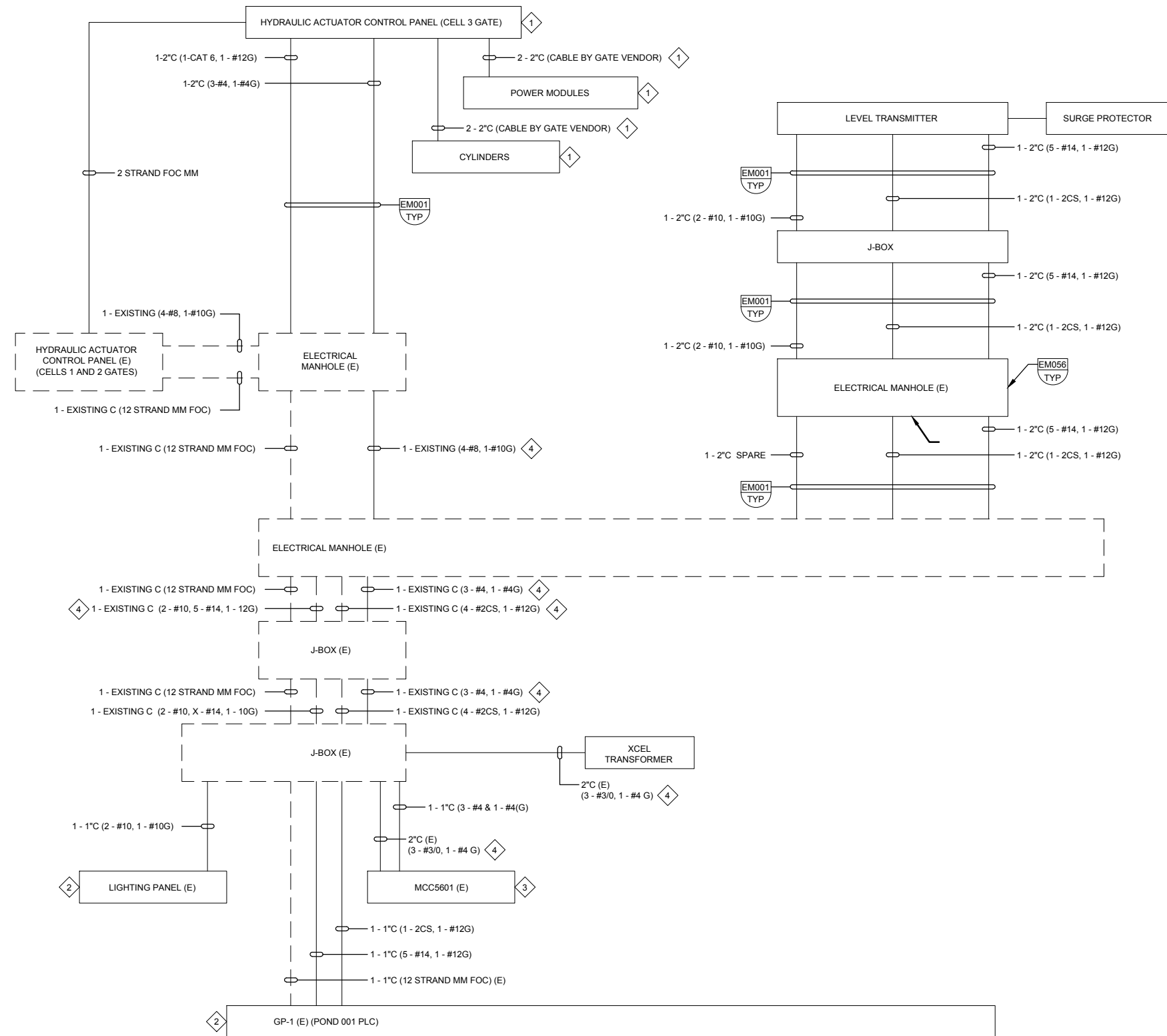

(E) = EXISTING

**KEY NOTES:**

- 1 SUPPLIED BY GATE VENDOR.
- 2 PROVIDE DEDICATED 20A, 1 POLE CIRCUIT BREAKER FOR 24VDC POWER SUPPLY IN POND 001 PLC.
- 3 PROVIDE 40AMP, 3 POLE, 4 WIRE, CIRCUIT BREAKER TO FEED CELL 3 GATE CONTROL PANEL.
- 4 EXISTING CONDUIT, NEW CONDUCTORS.



POND 001 EXPANSION

ISSUE RECORD

NO. BY PURPOSE DATE CKD

1 JK IFC 21NO17

SCALE

DATE JUNE 19, 2017

DRAWN BY: LP

CHECKED BY:

FAA AIP NO:

WORK BREAKDOWN NO.

DESIGN CONTRACT NO.

201418360

CONST. CONTRACT NO.

201418360 TASK 5

VOLUME NO.

1

SHEET TITLE

CONDUIT DEVELOPMENT PLAN

SHEET NO.

E 1020

49 OF 61

CADD FILE NO.

10697A1000E1020

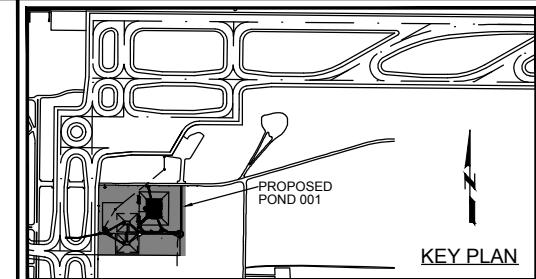

**KEY NOTES:**

- 1 EXISTING GATE NO. 1 & 2 CONTROL PANEL RACK. MATCH NEW GATE NO. 3 RACK.
- 2 EXISTING CELL BUBBLER PANEL. MATCH NEW LEVEL TRANSMITTER DUCT BANK TRANSITION WITH A NEMA 4X STAINLESS STEEL JUNCTION BOX.



POND 001 EXPANSION

ISSUE RECORD

| NO. | BY | PURPOSE | DATE   | CKD |
|-----|----|---------|--------|-----|
| 1   | JK | IFC     | 21NO17 |     |
|     |    |         |        |     |
|     |    |         |        |     |
|     |    |         |        |     |
|     |    |         |        |     |
|     |    |         |        |     |
|     |    |         |        |     |
|     |    |         |        |     |
|     |    |         |        |     |

SCALE

DATE JUNE 19, 2017

DRAWN BY: LP

CHECKED BY:

FAA AIP NO:

WORK BREAKDOWN NO.

DESIGN CONTRACT NO. 201418360

CONST. CONTRACT NO. 201418360 TASK 5

VOLUME NO. 1

SHEET TITLE  
ELECTRICAL  
EXISTING FIELD  
PANEL REFERENCE

SHEET NO. E1040

50 OF 61

CADD FILE NO. 10697A1000E1040



**A1** EXISTING HYDRAULIC CONTROL PANEL  
E2000



**B1** EXISTING BUBBLER PANEL AND DUCT BANK TRANSITION  
E2000





POND 001 EXPANSION

| ISSUE RECORD | NO. | BY  | PURPOSE | DATE | CKD |
|--------------|-----|-----|---------|------|-----|
| 1            | JK  | IFC | 21NO17  |      |     |

SCALE

DATE JUNE 19, 2017

DRAWN BY: SMB

CHECKED BY:

FAA AIP NO:

WORK BREAKDOWN NO:

DESIGN CONTRACT NO. 201418360

CONST. CONTRACT NO. 201418360 TASK 5

VOLUME NO. 1

SHEET TITLE  
ELECTRICAL  
GATE VCP  
CONTROL DIAGRAM

SHEET NO. E1050

51 OF 61

CADD FILE NO. 10697A1000E1050

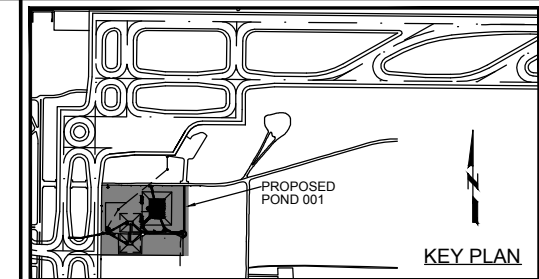

**SCOPE OF WORK:**

- CONTRACTOR TO INSTALL A PLC CONTROLLED SLUICE GATE WITH REMOTE COMMUNICATIONS TO EXISTING PLC IN PUMP HOUSE.
- THE CONTRACTOR SHALL MAINTAIN AB LOGIC IN PUMP-HOUSE PLC WITH MINIMAL CHANGES.
- LOCATE NEW RACK AS SHOWN ON THIS DRAWING WITH DISCONNECTS, GATE PLC CONTROL PANEL, AND SCUBA CONTROL PANEL AS SHOWN ON THIS DRAWING.
- PROVIDE A DIRECT COMM LINK BETWEEN GATE PLC CONTROL PANEL AND PUMP HOUSE CONTROL PANEL DUE TO DISTANCE LINK WILL BE FIBER.
- WHETHER SPECIFIED OR NOT PROVIDE ALL COMPONENTS NECESSARY TO PROVIDE AN OPERATIONAL SYSTEM.
- ALL FIELD COMPONENTS SHALL BE HARDENED AND SUITABLE FOR ENVIRONMENT ON SITE.
- PLC PROGRAMMING, RE-PROGRAM EXISTING PLC TO COORDINATE LOGIC WITH SEQUENCE OR OPERATIONS, SCUBA CONTROL, AND REMOTE CONTROL.

**KEYED NOTES:**

- 1A) EXISTING COMMUNICATION CARD IN EXISTING PUMPHOUSE AB PLC EQUAL TO 1747-L551 (OR PROSOFT TCP/IP MV169-MNET).
- 1B) FIBER OPTIC ETHERNET SWITCH EQUAL TO IFS D7600-MM-X 6PORT 10/100, 2 PORT 100FX MM, PROVIDE DIN RAIL MOUNTAIN AND POWER SUPPLY.
- 1C) FIBER OPTIC PATCH PANEL.
- 2) SLUICE GATE LOCAL CONTROL PANEL (LCP) ENCLOSURE, FURNISHED BY MFG, NEMA 4X-SS CABINET, WITH LOCKABLE DEAD FRONT EXTERIOR HANDLE, OPERATOR CONTROL INTERFERENCE ON SWING OUT MAGNETIC STRIP MOTOR CIRCUIT PROTECTOR, 3-PH NON-REVERSING STARTER WITH OVERLOADS, FUSES, RELAYS, ENCLOSURE HEATER, TSTAT CONTROLLED FAN AND FILTER, ROCKWELL COMPACTLOGIX PLC.
- 3) EXISTING ETHERNET/IP COMMUNICATION TO PUMP HOUSE PLC FOR I/O LOGIC COMMUNICATION BETWEEN NEW AND EXISTING PLC'S PROVIDE HARDENED FIBER CONVERTER, PROVIDE FIBER EQUAL TO 12 STRAND, 50 MICRON, OUTDOOR PLANT FIBER OPTIC CABLE.

**SEQUENCE OF OPERATIONS:**

- CONTRACTOR TO PROGRAM THE FOLLOWING INPUT SIGNALS TO NEW FOR EACH GATE.
  - HOA SWITCH FOR LOCAL TESTING
  - PB FOR SLUICE GATE 1 OPEN
  - PB FOR SLUICE GATE 2 OPEN
  - PB FOR SLUICE GATE 1 CLOSE
  - PB FOR SLUICE GATE 2 CLOSE
  - PB PUSH TO TEST LAMPS
  - PB RESET ALARM
- CONTRACTOR TO WIRE THE FOLLOWING OUTPUT SIGNALS TO NEW PLAC FOR EACH GATE.
  - SLUICE GATE 1 OPEN - GRN LT
  - SLUICE GATE 2 OPEN - GRN LT
  - SLUICE GATE 1 CLOSED - RED LT
  - SLUICE GATE 2 CLOSED - RED LT
  - LCP POWER ON - WHT LT
  - HYDRAULIC OIL LOSS - RED LT
  - SUMMARY ALARM-ROTATING BEACON
- CONTRACTOR TO MODIFY PLC IN PUMP HOUSE TO OPERATE GATE CONTROLS SIMILAR TO LOCAL OPERATOR INTERFACE.
- NOTES:
  - ONLY ONE GATE OPERATED IS USED AT A TIME.
  - CONTINUOUS POSITION NOT USED.
- COORDINATE PLC LOGIC WITH SEQUENCE OF OPERATIONS.
- PROVIDE 2-DAY ON SITE PLC-TECH SET-UP AND TRAINING AS PART OF SYSTEM INSTALLATION.

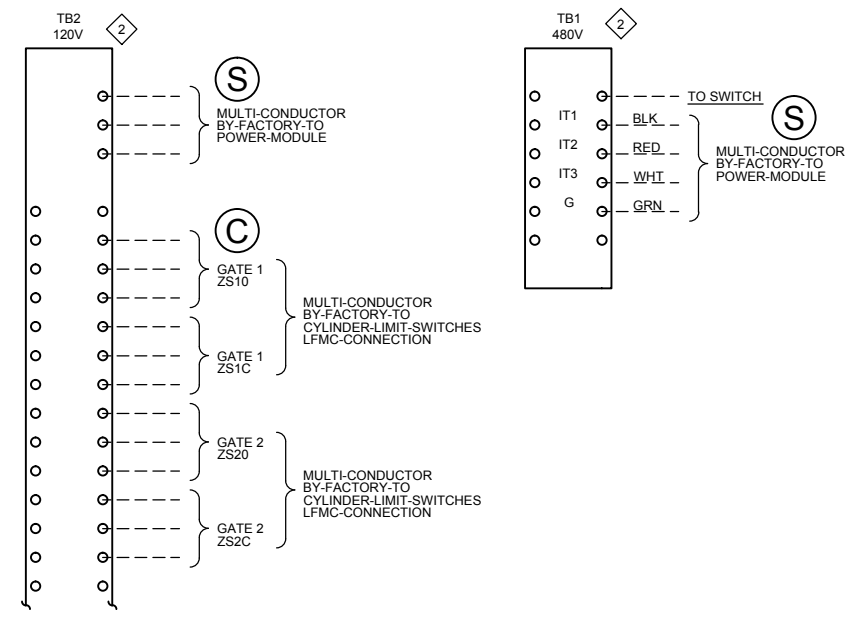

**(C)** - AT CYLINDER CHAMBER  
**(S)** - AT SCUBA ACTUATOR

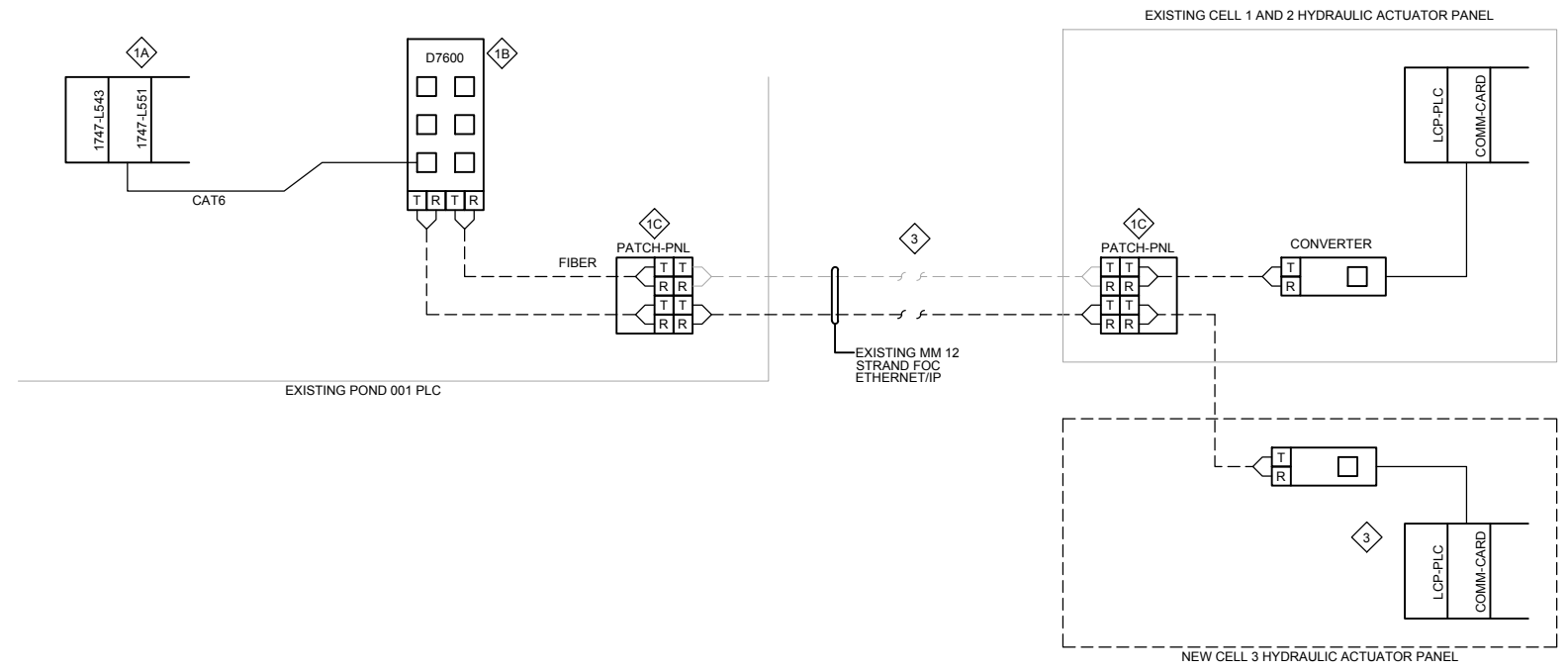



POND 001 EXPANSION

ISSUE RECORD

| NO. | BY | PURPOSE | DATE   | CKD |
|-----|----|---------|--------|-----|
| 1   | JK | IFC     | 21NO17 |     |

1 JK IFC 21NO17

SCALE

DATE JUNE 19, 2017

DRAWN BY: JRS

CHECKED BY:

FAA AIP NO:

WORK BREAKDOWN NO.

DESIGN CONTRACT NO. 201418360

CONST. CONTRACT NO. 201418360 TASK 5

VOLUME NO. 1

SHEET TITLE

ELECTRICAL  
MCC  
ELEVATION

SHEET NO.

E1060

52 OF 61

CADD FILE NO.

10697A1000E1060

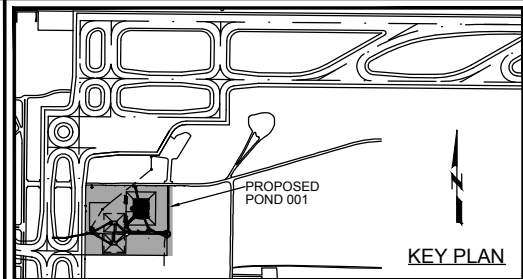

NOTES:

- 1 MCC NAMEPLATE DATA:  
WESTINGHOUSE SERIES 2100  
600 AMP HORIZONTAL BUS  
300 AMP VERTICAL BUS  
G.O. DS6660-260303 DNC
- 2 NOT USED.
- 3 REPLACE EXISTING MAIN BREAKER WITH A NEW 200 AMP 65 KAIC BREAKER.  
REPLACE EXISTING FEEDER CIRCUIT BACK TO EXISTING TRANSFORMER.
- 4 INSTALL NEW 45 AMP CIRCUIT BREAKER FOR NEW HYDRAULIC ACTUATOR CONTROL PANEL.
- 5 INSTALL NEW 3/4" CONDUIT WITH 120VAC POWER FROM PANEL LP EAST USING SPARE BREAKER ON CIRCUIT 11.
- 6 INSTALL NEW 24VDC POWER SUPPLY IN POND 001 PLC TO POWER THE NEW LEVEL TRANSMITTER.



**B** MCC ELEVATION  
SCALE: NO SCALE

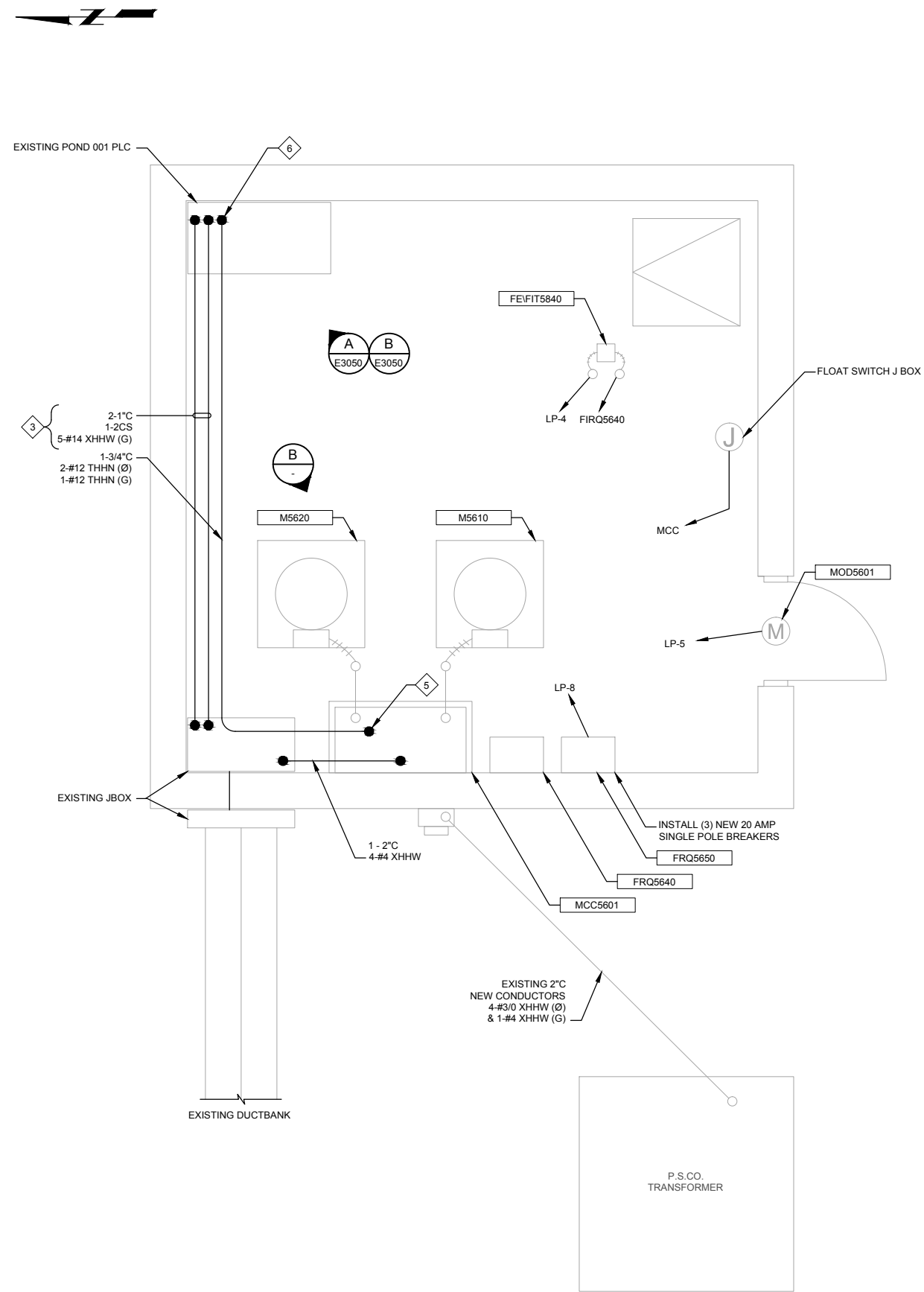

**A** PLAN  
SCALE: 1/2" = 1'-0"  
FILE: 10697A1001E105.2dm

C:\CAD\_Support\Unrelated\_DWG\_Files\10697A\1001E1005.dwg Nov 20, 2017 - 9:23am broopken



POND 001 EXPANSION

| NO. | BY | PURPOSE | DATE   | CKD |
|-----|----|---------|--------|-----|
| 1   | JK | IFC     | 21NO17 |     |

SCALE

DATE JUNE 19, 2017

DRAWN BY: LP

CHECKED BY:

FAA AIP NO:

WORK BREAKDOWN NO:

DESIGN CONTRACT NO. 201418360

CONST. CONTRACT NO. 201418360 TASK 5

VOLUME NO. 1

SHEET TITLE

ELECTRICAL  
SITE PLAN

SHEET NO.

E2000

53 OF 61

CADD FILE NO.

10697A1000E2000

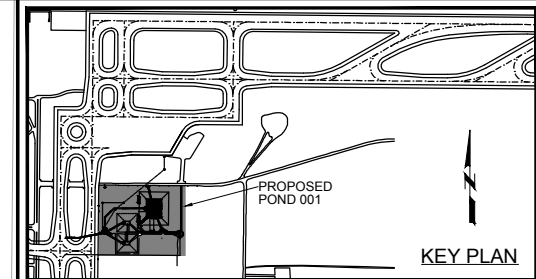

KEY NOTES:

- 1 CONTRACTOR TO COORDINATE WITH DIA PROJECT MANAGER FOR ALL CONNECTIONS TO EXISTING SYSTEMS. UNDER NO CIRCUMSTANCES WILL THE CONTRACTOR OPERATE ANY EQUIPMENT.
- 2 CONTRACTOR TO INSTALL NEW DUCT BANK FROM EXISTING MANHOLE TO NEW POND 1 CELL 3 VALVE VAULT.
- 3 CONTRACTOR TO INSTALL NEW VENDOR EQUIPMENT FOR GATE NO. 3. MATCH FORM AND FUNCTION OF EXISTING GATE VENDOR CONTROL EQUIPMENT.
- 4 PROVIDE PULL ROPES IN ALL NEW SPARE CONDUITS.

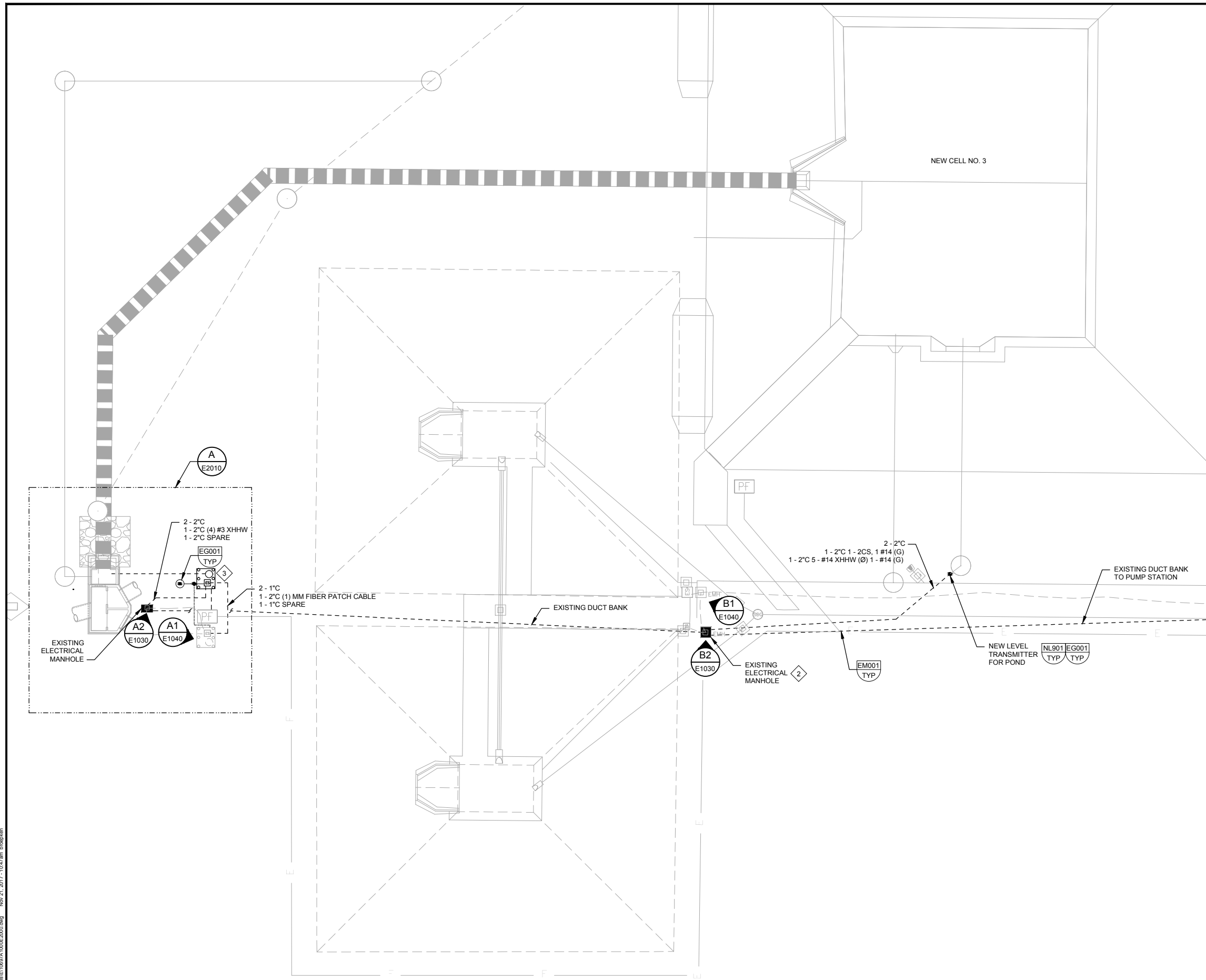

**A** SITE PLAN  
SCALE: 1" = 30'  
FILE: 10697A1000E101



POND 001 EXPANSION

| NO. | BY | PURPOSE | DATE   | CHKD |
|-----|----|---------|--------|------|
| 1   | JK | IFC     | 21NO17 |      |

SCALE

DATE JUNE 19, 2017

DRAWN BY: JRS

CHECKED BY:

FAA AIP NO:

WORK BREAKDOWN NO:

DESIGN CONTRACT NO. 201418360

CONST. CONTRACT NO. 201418360 TASK 5

VOLUME NO. 1

SHEET TITLE

ELECTRICAL  
SITE  
DETAILS

SHEET NO.

E2010

54 OF 61

CADD FILE NO. 10697A1000E2010

NOTES:

- 1 INSTALL TWO NEW 1 INCH FIBER CONDUIT BETWEEN NEW HYDRAULIC GATE CONTROLLER AND EXISTING HYDRAULIC GATE CONTROLLER.
- 2 INSTALL FIBER OPTIC PATCH CABLE IN 1 INCH CONDUIT. PATCH INTO EXISTING PATCH PANEL LOCATED IN EXISTING HYDRAULIC CONTROL PANEL, TO MEDIA CONVERTOR IN NEW HYDRAULIC CONTROL PANEL.
- 3 6" CONCRETE FILLED BOLLARDS 6" FROM EDGE OF CONCRETE PAD.
- 4 6.25'X9'X4" (6.25 SY) PCC PAD FOR POWER MODULE AND ELECTRICAL EQUIPMENT RACK.
- 5 PROVIDE SUN SHADE TO PROTECT HYDRAULIC ACTUATOR CONTROL PANEL AND ACCUMULATOR TANK TO MATCH EXISTING.
- 6 PROVIDE LIGHTING ARRESTOR, MATCH EXISTING HYDRAULIC ACTUATOR SUN SHIELD.
- 7 CONNECT NEW GROUND TO EXISTING GROUND GRID AND LIGHTING PROTECTION DOWN LINE.
- 8 ALL GROUND CONDUCTORS SHALL BE BARE #4/0.

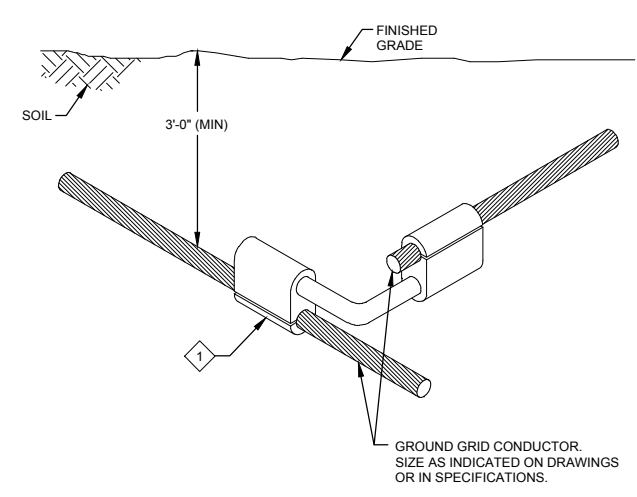
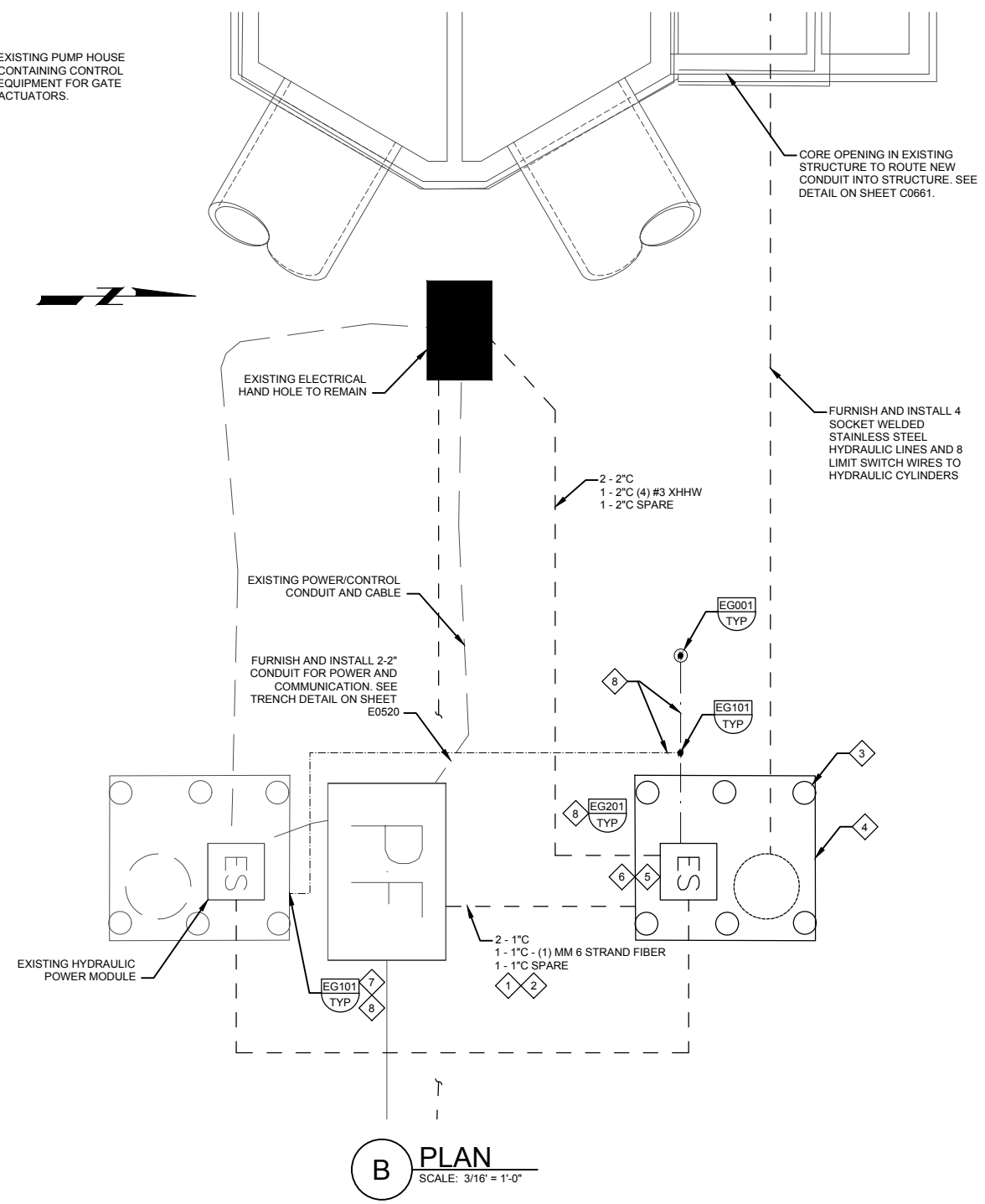
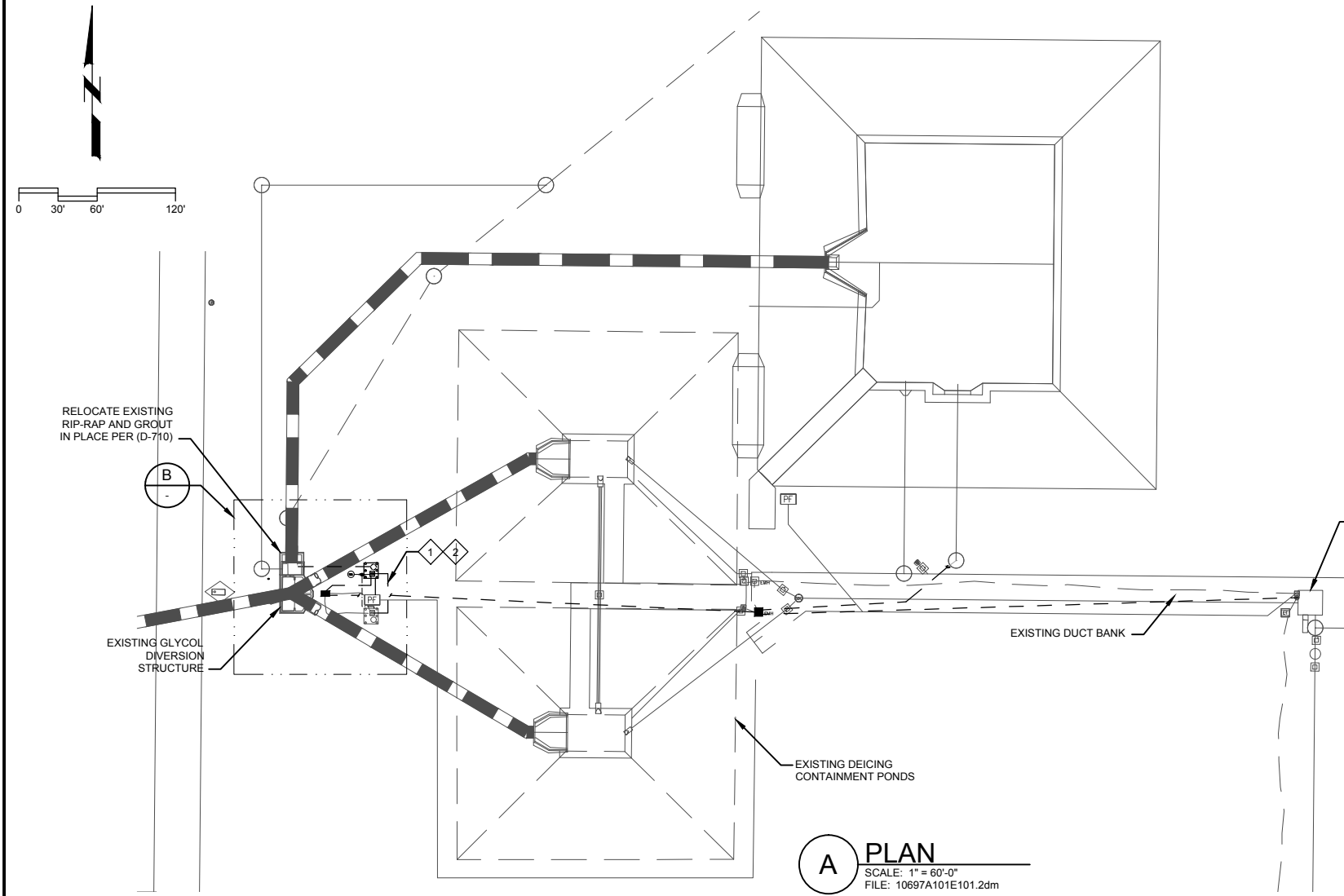

**EG101**  
TYP  
COPPER GROUNDING CABLE CONNECTION  
COMPRESSION CONNECTION

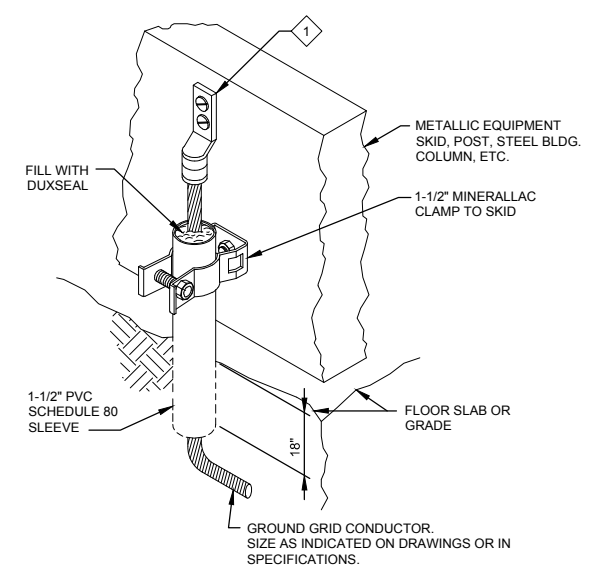

**EG201**  
TYP  
EQUIPMENT SKID GROUNDING  
COMPRESSION CONNECTION

- NOTES:
1. CLEAN ALL PAINTED SURFACES TO BARE METAL BEFORE BOLTING ON THE GROUND LUG.
  2. NOTE: BOLT GROUND LUG ONLY TO EQUIPMENT SKIDS OR STRUCTURE, NOT TO EQUIPMENT OR TANK SHELLS.
- KEY NOTES:
- 1 HEAVY DUTY COMPRESSION TERMINAL.

C:\CAD\_Support\Transmitted\_DWG\_Files\10697A1000E2010.dwg Nov 21, 2017 - 10:48am brooklyn



POND 001 EXPANSION

ISSUE RECORD  
NO. BY PURPOSE DATE CKD  
1 JK IFC 21NO17

| SYMBOL  | DRAWING VISIBLE FIELDS   | FIELD - 1  | FIELD - 2 | FIELD - 3  | FIELD - 4   | FIELD - 5   | FIELD - 6                  |
|---|--|--|-----------|--|-------------|---|----------------------------|
| SCADA SYSTEM OPERATOR INTERFACE TERMINAL                        | 1 - TAG<br>2 - LOOP NUMBER<br>3 - FUNCTION<br>4 - DESCRIPTION<br>5 - DESCRIPTION<br>6 - EXISTING/FUTURE    | REFER  | REFER     | ACTION ALARM NUM - NUMERIC<br>SP - SET POINT<br>STATUS<br>TREND  | DESCRIPTION | DESCRIPTION   | E - EXISTING<br>F - FUTURE |
| HARDWIRED I/O POINT   | 1 - TAG<br>2 - LOOP NUMBER<br>3 - FUNCTION<br>4 - DESCRIPTION<br>5 - LOCATION<br>6 - EXISTING/FUTURE       | REFER  | REFER     | AI - ANALOG INPUT<br>AO - ANALOG OUTPUT<br>DI - DISCRETE INPUT<br>DO - DISCRETE OUTPUT<br>HSC - HIGH SPEED COUNTER INPUT<br>RTD - RTD INPUT  | DESCRIPTION | PAC - PROGRAMMABLE AUTOMATION CONTROLLER NO.<br>PLC - PROGRAMMABLE LOGIC CONTROLLER NO.<br>RIO - REMOTE I/O<br>VCP - VENDOR CONTROL PANEL NO.   | E - EXISTING<br>F - FUTURE |
| DIGITAL BUS I/O REGISTER (FIELD BUS I/O)                        | 1 - TAG<br>2 - LOOP NUMBER<br>3 - FUNCTION<br>4 - DESCRIPTION<br>5 - LOCATION<br>6 - EXISTING/FUTURE       | REFER  | REFER     | BUS ID<br>CNET - CONTROLNET<br>DNET - DEVICENET<br>ENET - ETHERNET/IP<br>FF - FOUNDATION FIELDBUS<br>MB - MODBUS RTU<br>MB+ - MODBUS PLUS<br>MBTCP - MODBUS TCP<br>DP - PROFIBUS DP<br>PA - PROFIBUS PA<br>PNET - PROFINET<br>SERIAL - PROPRIETARY PROTOCOL  | DESCRIPTION | PAC - PROGRAMMABLE AUTOMATION CONTROLLER NO.<br>PLC - PROGRAMMABLE LOGIC CONTROLLER NO.<br>RIO - REMOTE I/O<br>VCP - VENDOR CONTROL PANEL NO.   | E - EXISTING<br>F - FUTURE |
| HUMAN MACHINE INTERFACE   | 1 - TAG<br>2 - LOOP NUMBER<br>3 - FUNCTION<br>4 - DESCRIPTION<br>5 - LOCATION<br>6 - EXISTING/FUTURE       | REFER  | REFER     | ACTION ALARM NUM - NUMERIC<br>SP - SET POINT<br>STATUS   | DESCRIPTION | HMI - HUMAN MACHINE INTERFACE NO.<br>LCP - LOCAL CONTROL PANEL NO.<br>PCM - PROCESS CONTROL MODULE NO.<br>VCP - VENDOR CONTROL PANEL NO.  | E - EXISTING<br>F - FUTURE |
| PILOT DEVICE OPERATOR INTERFACE                                 | 1 - TAG<br>2 - LOOP NUMBER<br>3 - FUNCTION<br>4 - DESCRIPTION<br>5 - LOCATION<br>6 - EXISTING/FUTURE       | REFER  | REFER     | AM - AUTO/MANUAL BYPASS<br>CL - CLOSE<br>E-STOP - EMERGENCY STOP<br>FRLR - FIXED RATE/LEVEL RATE<br>HOA - HAND /OFF/AUTO<br>JOHC - JOG OPEN/HOLD/CLOSE<br>JOJC - JOG OPEN/JOG CLOSE<br>LH - LOW/HIGH<br>LOR - LOCAL/OFF/REMOTE<br>LOS - LOCK OUT STOP<br>LS - LEAD/STANDBY<br>LSR - LOCAL/STOP/REMOTE<br>NOOT - NO OFFLINE/OFFLINE TRANSITION<br>OC - OPEN/CLOSE<br>OLOL - ON LINE/OFF LINE<br>OD - OFF/ON<br>OP - OPEN<br>OSC - OPEN/STOP/CLOSE<br>RST - RESET<br>SAAM - SEMI AUTO/AUTO/MANUAL<br>SEL - SELECT<br>SP - STOP<br>SPD - SPEED<br>SS - START/STOP<br>ST - START | DESCRIPTION | LCP - LOCAL CONTROL PANEL NO.<br>MCC - MOTOR CONTROL CENTER NO.<br>PCM - PROCESS CONTROL MODULE NO.<br>RVSS - REDUCED VOLTAGE SOLID STARTER NO.<br>VCP - VENDOR CONTROL PANEL NO.<br>VFD - VARIABLE FREQUENCY DRIVE NO. | E - EXISTING<br>F - FUTURE |
| POWER DEVICE PRIMARY FUNCTION OPERATOR ACCESSIBLE               | 1 - TAG<br>2 - LOOP NUMBER<br>3 - FUNCTION<br>4 - VOLTAGE/PHASE<br>5 - LOCATION<br>6 - EXISTING/FUTURE     | CB - CIRCUIT BREAKER<br>DISC - DISCONNECT<br>FU - FUSE | REFER     | TM - THERMAL MAGNETIC CIRCUIT BREAKER  | DESCRIPTION | DESCRIPTION   | E - EXISTING<br>F - FUTURE |
| POWER DEVICE AUXILIARY FUNCTION FOR OPERATOR ACCESSIBLE DEVICES | 1 - TAG<br>2 - LOOP NUMBER<br>3 - DESCRIPTION<br>4 - DESCRIPTION<br>5 - DESCRIPTION<br>6 - EXISTING/FUTURE | DISC - DISCONNECT                                      | REFER     | DESCRIPTION  | DESCRIPTION | DESCRIPTION   | E - EXISTING<br>F - FUTURE |
| POWER DEVICE PRIMARY FUNCTION OPERATOR INACCESSIBLE             | 1 - TAG<br>2 - LOOP NUMBER<br>3 - FUNCTION<br>4 - VOLTAGE/PHASE<br>5 - LOCATION<br>6 - EXISTING/FUTURE     | CB - CIRCUIT BREAKER<br>FU - FUSE                      | REFER     | MCP - MOTOR CIRCUIT PROTECTOR<br>SS - SOLID STATE CIRCUIT BREAKER<br>TM - THERMAL MAGNETIC CIRCUIT BREAKER   | DESCRIPTION | DESCRIPTION   | E - EXISTING<br>F - FUTURE |

| SYMBOL  | DRAWING VISIBLE FIELDS   | FIELD - 1   | FIELD - 2 | FIELD - 3  | FIELD - 4   | FIELD - 5   | FIELD - 6                  |
|---|--|---|-----------|--|-------------|---|----------------------------|
| INSTRUMENT PRIMARY ELEMENT  | 1 - TAG<br>2 - LOOP NUMBER<br>3 - FUNCTION<br>4 - FURNISHED BY<br>5 - LOCATION<br>6 - EXISTING/FUTURE      | REFER   | REFER     | DESCRIPTION  | DESCRIPTION | AREA NO. BUILDING NO. ROOM NO.  | E - EXISTING<br>F - FUTURE |
| INSTRUMENT/CONTROL ELEMENT PRIMARY FUNCTION OPERATOR ACCESSIBLE     | 1 - TAG<br>2 - LOOP NUMBER<br>3 - FUNCTION<br>4 - FURNISHED BY<br>5 - LOCATION<br>6 - EXISTING/FUTURE      | REFER   | REFER     | DESCRIPTION  | DESCRIPTION | DESCRIPTION   | E - EXISTING<br>F - FUTURE |
| INSTRUMENT/CONTROL ELEMENT AUXILIARY FUNCTION OPERATOR ACCESSIBLE   | 1 - TAG<br>2 - LOOP NUMBER<br>3 - FUNCTION<br>4 - FURNISHED BY<br>5 - LOCATION<br>6 - EXISTING/FUTURE      | REFER   | REFER     | DESCRIPTION  | DESCRIPTION | DESCRIPTION   | E - EXISTING<br>F - FUTURE |
| INSTRUMENT/CONTROL ELEMENT PRIMARY FUNCTION OPERATOR INACCESSIBLE   | 1 - TAG<br>2 - LOOP NUMBER<br>3 - FUNCTION<br>4 - FURNISHED BY<br>5 - LOCATION<br>6 - EXISTING/FUTURE      | REFER   | REFER     | DESCRIPTION  | DESCRIPTION | LCP - LOCAL CONTROL PANEL NO.<br>MCC - MOTOR CONTROL CENTER NO.<br>PCM - PROCESS CONTROL MODULE NO.<br>VCP - VENDOR CONTROL PANEL NO. | E - EXISTING<br>F - FUTURE |
| INSTRUMENT/CONTROL ELEMENT AUXILIARY FUNCTION OPERATOR INACCESSIBLE | 1 - TAG<br>2 - LOOP NUMBER<br>3 - FUNCTION<br>4 - FURNISHED BY<br>5 - LOCATION<br>6 - EXISTING/FUTURE      | REFER   | REFER     | DESCRIPTION  | DESCRIPTION | LCP - LOCAL CONTROL PANEL NO.<br>MCC - MOTOR CONTROL CENTER NO.<br>PCM - PROCESS CONTROL MODULE NO.<br>VCP - VENDOR CONTROL PANEL NO. | E - EXISTING<br>F - FUTURE |
| FIELD EQUIPMENT NON-POWERED   | 1 - TAG<br>2 - LOOP NUMBER<br>3 - FUNCTION/SIZE<br>4 - FURNISHED BY<br>5 - LOCATION<br>6 - EXISTING/FUTURE | REFER   | REFER     | DESCRIPTION  | DESCRIPTION | AREA NO. BUILDING NO. ROOM NO.  | E - EXISTING<br>F - FUTURE |
| FIELD EQUIPMENT PRIMARY FUNCTION POWERED                            | 1 - TAG<br>2 - LOOP NUMBER<br>3 - FUNCTION<br>4 - FURNISHED BY<br>5 - LOCATION<br>6 - EXISTING/FUTURE      | REFER   | REFER     | DESCRIPTION  | DESCRIPTION | AREA NO. BUILDING NO. ROOM NO.  | E - EXISTING<br>F - FUTURE |
| FIELD EQUIPMENT AUXILIARY FUNCTION POWERED                          | 1 - TAG<br>2 - LOOP NUMBER<br>3 - FUNCTION<br>4 - FURNISHED BY<br>5 - LOCATION<br>6 - EXISTING/FUTURE      | MWH - MOTOR WINDING HEATER<br>TSH - TEMPERATURE SWITCH<br>XSH - TORQUE SWITCH   | REFER     | DESCRIPTION  | DESCRIPTION | DESCRIPTION   | E - EXISTING<br>F - FUTURE |
| FIELD EQUIPMENT STARTER/DRIVE CUBICLE/CABINET                       | 1 - TAG<br>2 - LOOP NUMBER<br>3 - TYPE<br>4 - VOLTAGE/PHASE<br>5 - LOCATION<br>6 - EXISTING/FUTURE         | MS - MOTOR STARTER<br>RVAT - REDUCED VOLTAGE AUTO TRANSFORMER STARTER<br>RVSS - REDUCED VOLTAGE SOLID STATE STARTER<br>VFD - VARIABLE FREQUENCY DRIVE | REFER     | FVNR - FULL VOLTAGE NON-REVERSING STARTER<br>FVR - FULL VOLTAGE REVERSING STARTER<br>PWS - PART-WINDING STARTER<br>RVAT - REDUCED VOLTAGE AUTO TRANSFORMER STARTER<br>RVSS - REDUCED VOLTAGE SOLID STATE STARTER<br>TS1W - TWO SPEED SINGLE WINDING<br>TS2W - TWO SPEED TWO WINDINGS<br>VFD - VARIABLE FREQUENCY DRIVE | DESCRIPTION | LCP - LOCAL CONTROL PANEL NO.<br>MCC - MOTOR CONTROL CENTER NO.<br>PCM - PROCESS CONTROL MODULE NO.<br>VCP - VENDOR CONTROL PANEL NO. | E - EXISTING<br>F - FUTURE |

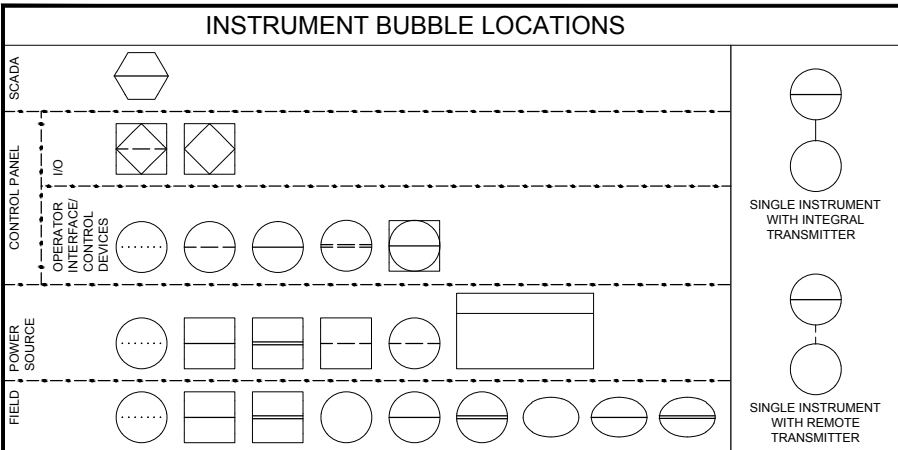

**NOTES**

- 1 INSTRUMENT TAG IDENTIFICATION LETTERS TABLE
- 2 OPERATOR PILOT DEVICE LEGEND
- 3 EQUIPMENT TAGGING TABLE
- 4 I/O TYPE DESIGNATIONS TABLE
- 5 INSTRUMENT TYPE DESIGNATIONS TABLE
- 6 FURNISHED BY: FBO FURNISHED BY OWNER  
FBV FURNISHED BY VENDOR

C:\CAD\_Support\Transmitted\_DWG\_Files\N10697A1000E300.dwg Nov 21, 2017 - 10:50am brespen

SCALE \_\_\_\_\_  
DATE JUNE 19, 2017  
DRAWN BY: BPR  
CHECKED BY: AS  
FAA AIP NO. \_\_\_\_\_  
WORK BREAKDOWN NO. \_\_\_\_\_  
DESIGN CONTRACT NO. \_\_\_\_\_  
CONST. CONTRACT NO. 201418360  
201418360 TASK 5  
VOLUME NO. \_\_\_\_\_  
SHEET TITLE 1  
**INSTRUMENTATION SYMBOLS & ABBREVIATIONS**  
SHEET NO. \_\_\_\_\_  
E3000  
55 OF 61  
CADD FILE NO. \_\_\_\_\_  
10697A1000E3000

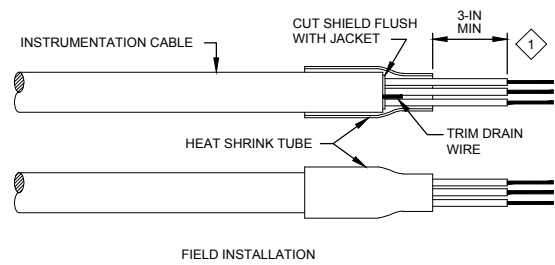
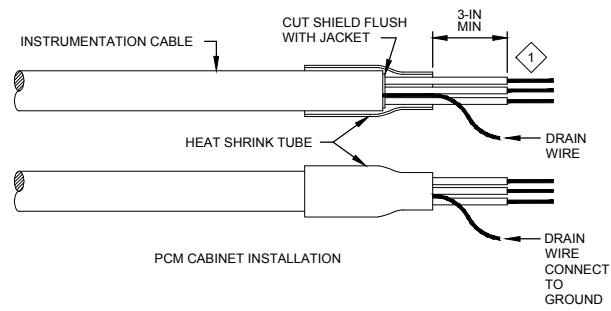

KEY NOTES:  
 1 SIMILAR FOR 2-CONDUCTOR SHIELDED CABLE

**NE101** TERMINATION DETAILS  
 TYP INSTRUMENTATION SHIELDED CABLE

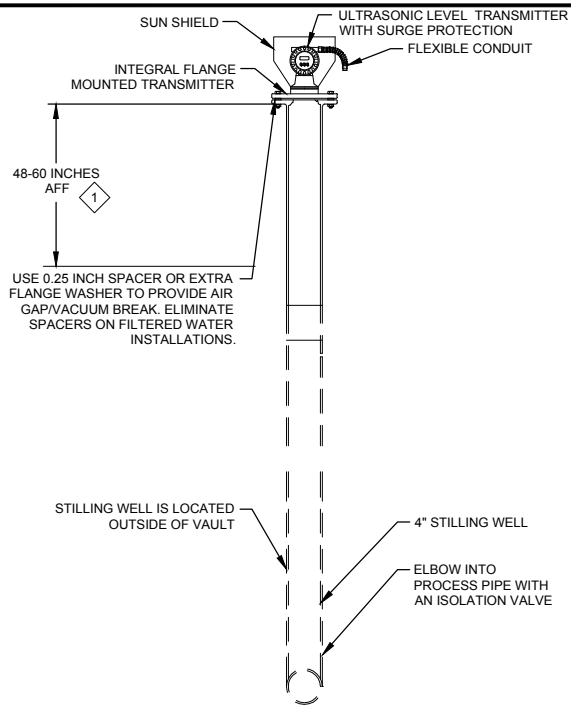

KEY NOTES:  
 1 MINIMUM DISTANCE BETWEEN HIGHEST POSSIBLE LEVEL, INCLUDING OVERFLOW, AND PROBE FACE SHALL BE MANUFACTURER'S BLANKING ZONE PLUS 2 INCHES.

NOTES:  
 1. PROVIDE SCHEDULE 80 PVC STILLING WELL. COORDINATE WITH MANUFACTURER FOR REQUIRED MINIMUM DIAMETER.

**NL901** ULTRASONIC LEVEL TRANSDUCER STILLING  
 TYP WELL MOUNTING DETAIL



POND 001 EXPANSION

| ISSUE RECORD | NO. | BY  | PURPOSE | DATE | CHKD |
|--------------|-----|-----|---------|------|------|
| 1            | JK  | IFC | 21NO17  |      |      |

SCALE

DATE JUNE 19, 2017

DRAWN BY: LP

CHECKED BY: AS

FAA AIP NO:

WORK BREAKDOWN NO:

DESIGN CONTRACT NO. 201418360

CONST. CONTRACT NO. 201418360 TASK 5

VOLUME NO. 1

SHEET TITLE  
**INSTRUMENTATION  
 TYPICAL  
 DETAILS**

SHEET NO.  
**E3015**

CADD FILE NO.  
 10697A1000E3015

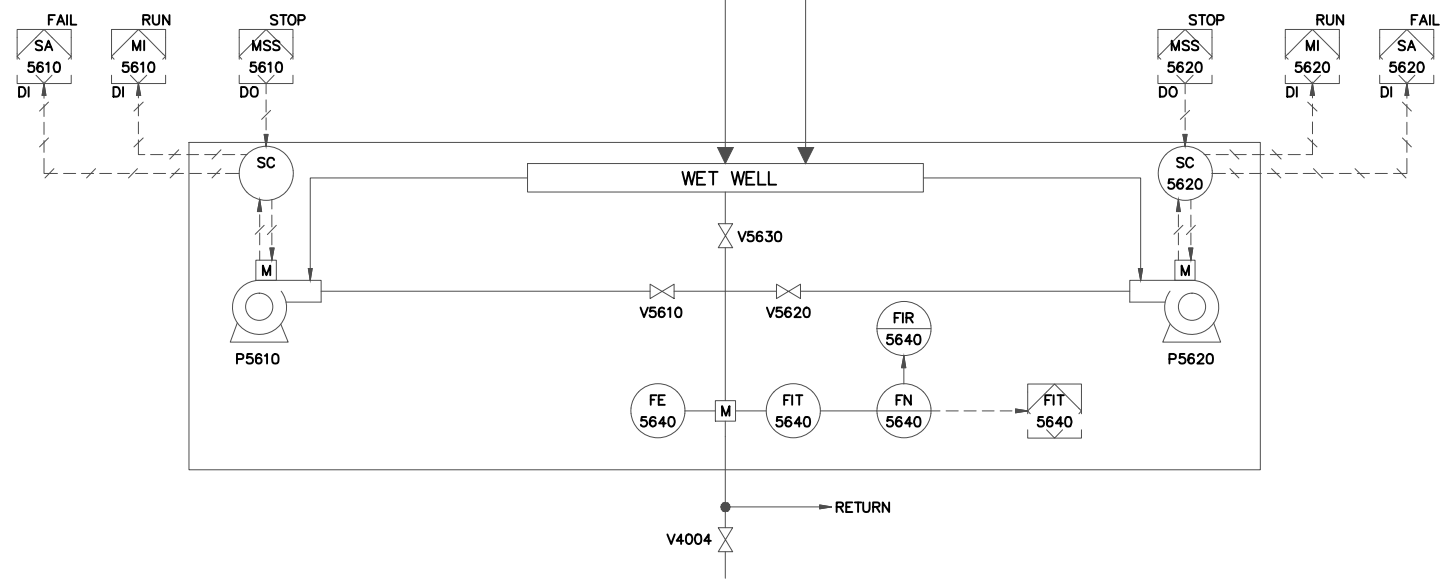
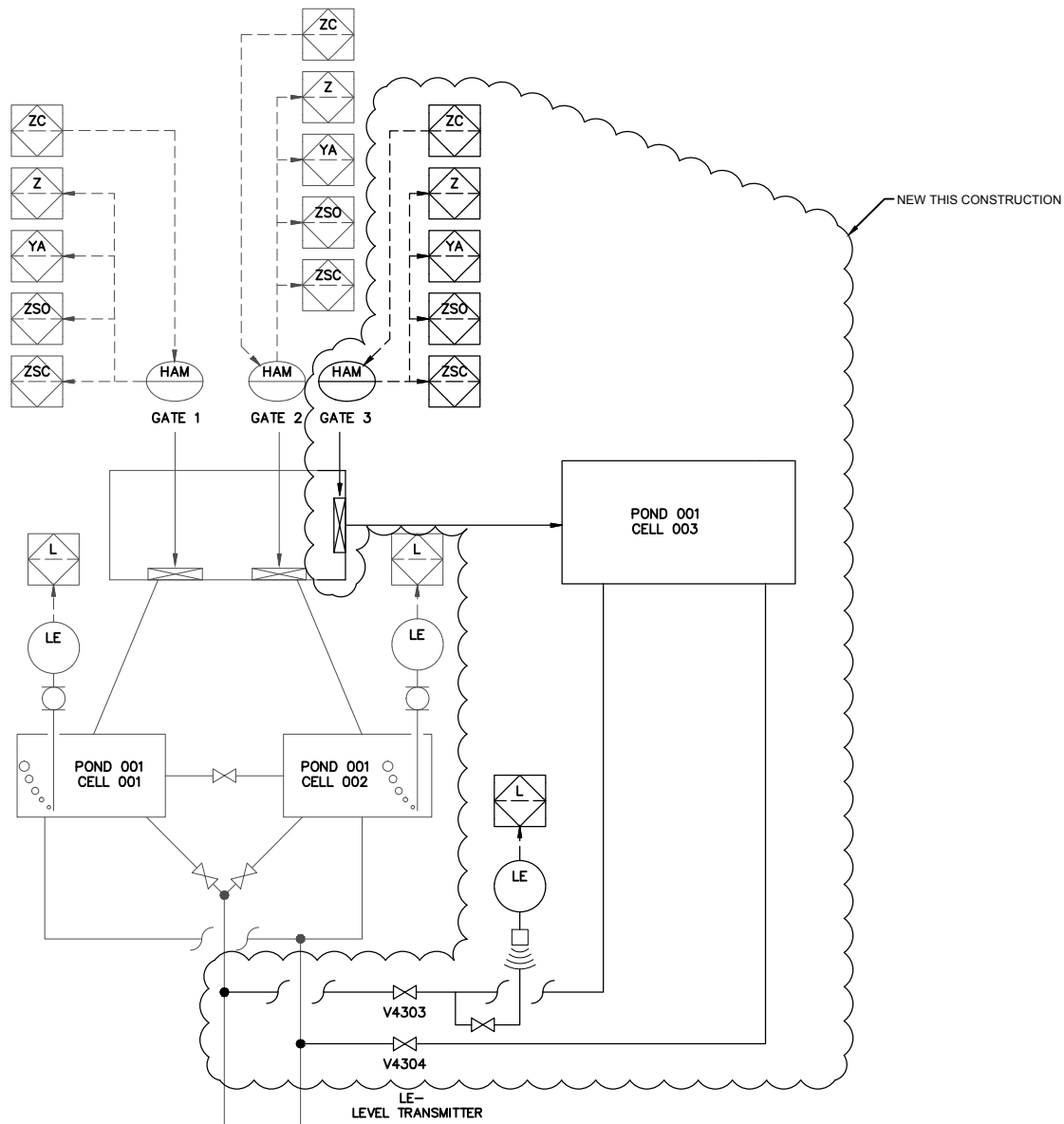

PROCESS & INSTRUMENTATION DIAGRAM  
POND 001

- KEY NOTES:**
- 1 FLANGE MOUNTED ULTRASONIC LEVEL TRANSMITTER.
  - 2 ENDRESS AND HAUSER FMU 43 4-WIRE 4 - 20 MA HART 24VDC POWER WITH 4-IN. FLANGE INTEGRAL SENSOR WITH HEATER. PROVIDE SURGE ARRESTOR INSTALLED AND WIRED ON THE TRANSMITTER.
  - 3 PROVIDE AND INSTALL SUN SHIELD ON LEVEL TRANSMITTER.



POND 001 EXPANSION

ISSUE RECORD

| NO. | BY | PURPOSE | DATE   | CHKD |
|-----|----|---------|--------|------|
| 1   | JK | IFC     | 21NO17 |      |

SCALE

DATE JUNE 19, 2017

DRAWN BY: LP

CHECKED BY: AS

FAA AIP NO:

WORK BREAKDOWN NO:

DESIGN CONTRACT NO. 201418360

CONST. CONTRACT NO. 201418360 TASK 5

VOLUME NO. 1

SHEET TITLE  
PROCESS AND INSTRUMENTATION DIAGRAM (P&ID)

SHEET NO. E3020

57 OF 61

CADD FILE NO. 10697A1000E3020

C:\CAD\_Support\Transmitted\_DWG\_Files\N10697A1000E3020.dwg Nov 21, 2017 - 10:51am bropken

C:\CAD\_Support\Transmitted\_DWG\_Files\N10697A1000E303.dwg Nov 21, 2017 - 10:51am bropken

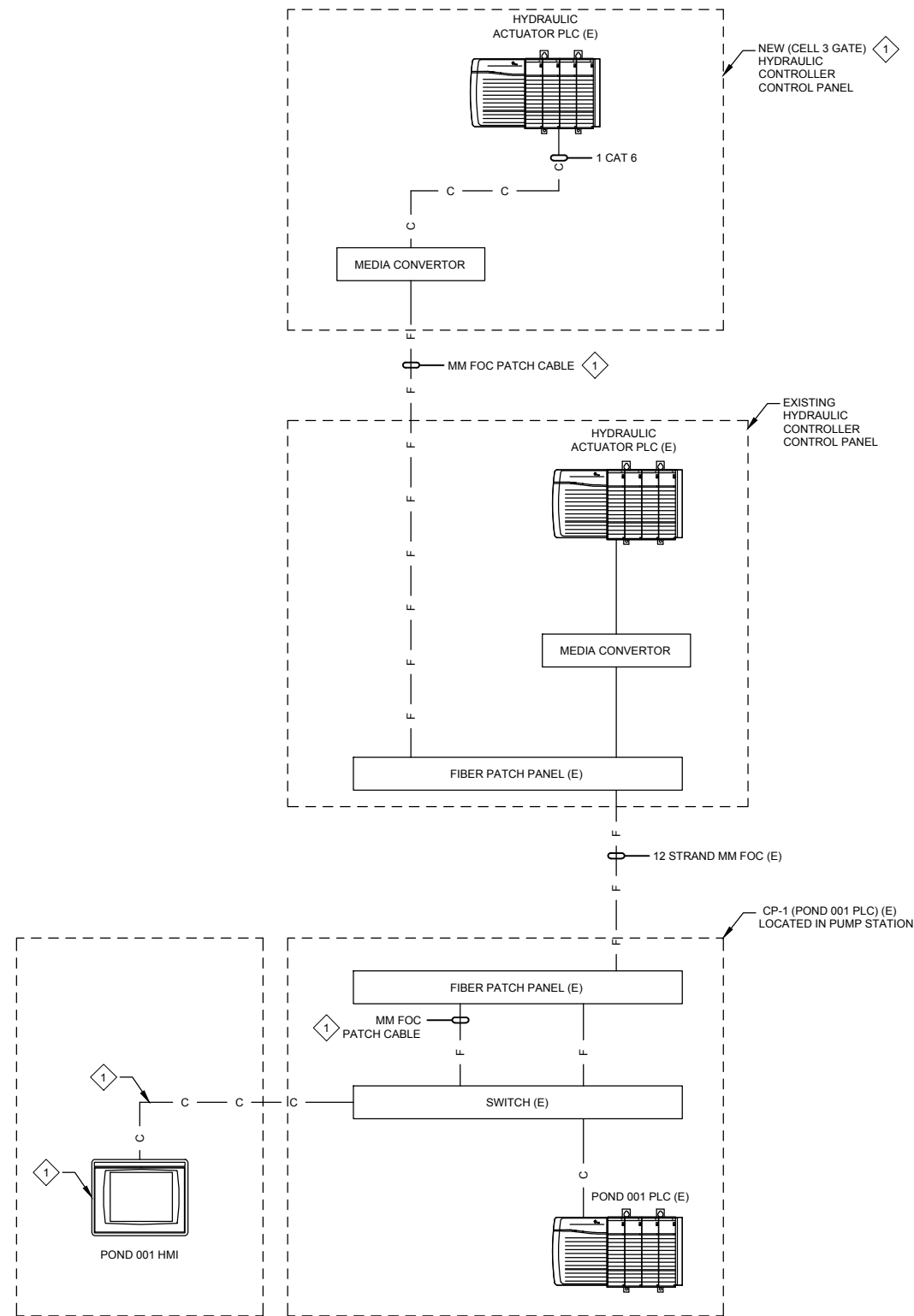

(E) = EXISTING

KEY NOTES:

1 NEW THIS CONSTRUCTION.

CITY & COUNTY  
of DENVER

DENVER  
INTERNATIONAL  
AIRPORT



POND 001 EXPANSION

ISSUE RECORD

NO. BY PURPOSE DATE CKD

1 JK IFC 21NO17

SCALE

DATE JUNE 19, 2017

DRAWN BY: LP

CHECKED BY:

FAA AIP NO:

WORK BREAKDOWN NO.

DESIGN CONTRACT NO.

201418360

CONST. CONTRACT NO.

201418360 TASK 5

VOLUME NO.

1

SHEET TITLE

NETWORK  
BLOCK  
DIAGRAM

SHEET NO.

E3030

58 OF 61

CADD FILE NO.

10697A1000E3030



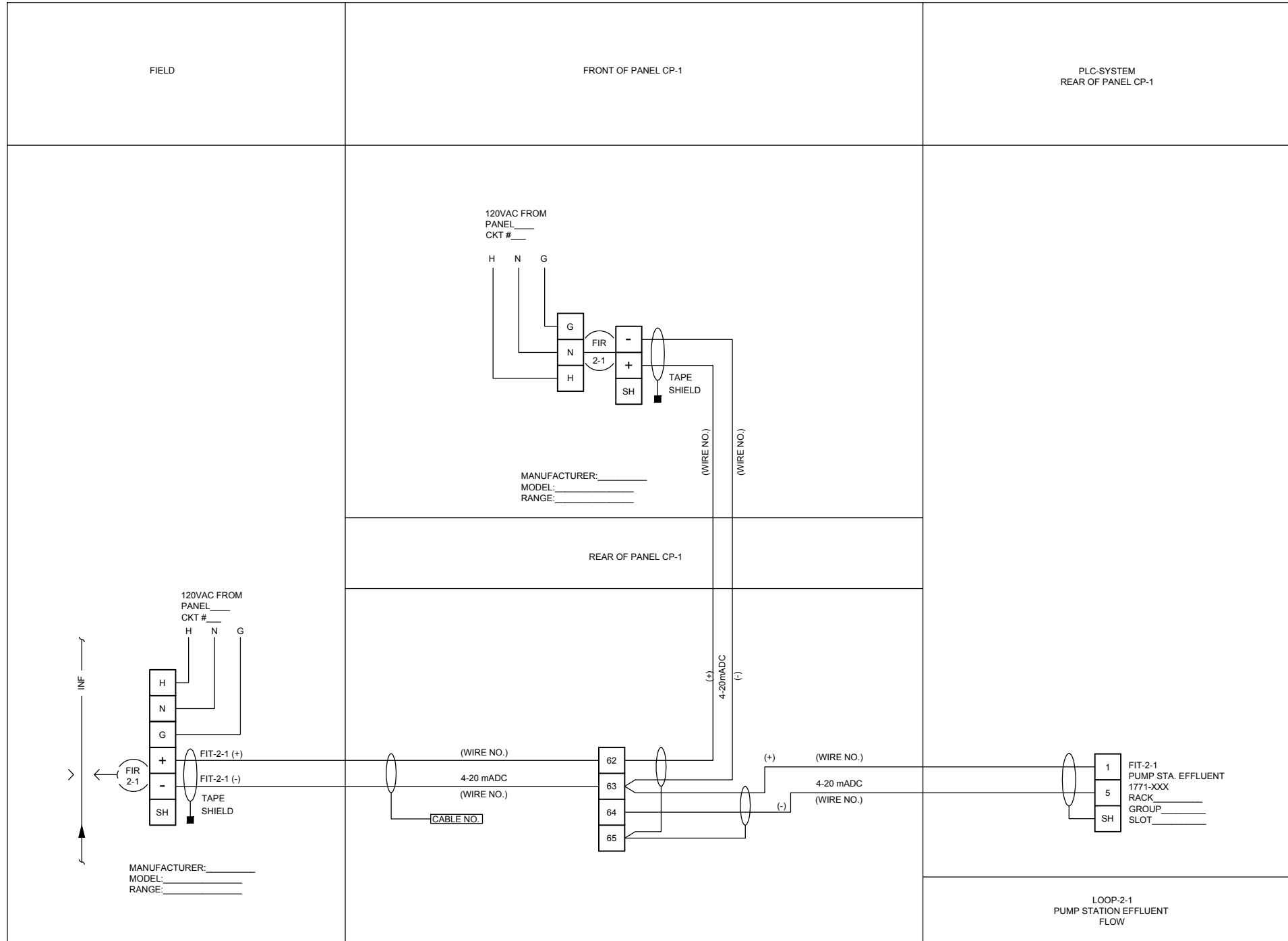

MINIMUM REQUIRED LOOP DRAWING FORMAT AND CONTENTS

GENERAL NOTES:

1. ALL THE INFORMATION TO BE FURNISHED BY THE SUPPLIER OF THE EQUIPMENT.

CITY & COUNTY of DENVER

DENVER INTERNATIONAL AIRPORT



POND 001 EXPANSION

| NO. | BY | PURPOSE | DATE   | CHKD |
|-----|----|---------|--------|------|
| 1   | JK | IFC     | 21NO17 |      |

SCALE

DATE JUNE 19, 2017

DRAWN BY: LP

CHECKED BY: AS

FAA AIP NO:

WORK BREAKDOWN NO.

DESIGN CONTRACT NO. 201418360

CONST. CONTRACT NO. 201418360 TASK 5

VOLUME NO. 1

SHEET TITLE  
 LOOP DIAGRAM  
 STANDARD  
 DETAIL

SHEET NO.

E3040

59 OF 61

CADD FILE NO.  
 10697A1000E3040

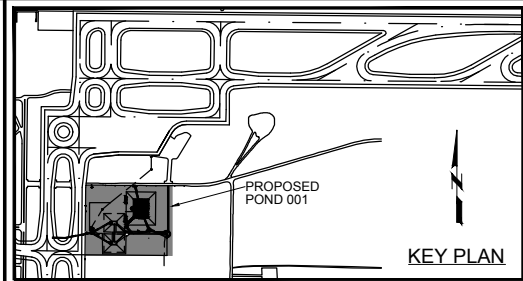

**KEY NOTES:**

- 1 CONTRACTOR TO COORDINATE WITH DIA PROJECT MANAGER FOR ALL CONNECTIONS TO EXISTING SYSTEMS. UNDER NO CIRCUMSTANCES WILL THE CONTRACTOR OPERATE ANY VALVES OR GATES.
- 2 REMOVE EXISTING DIGITAL DISPLAY. ADD COVER PLATE TO PATH HOLE.
- 3 REARRANGE EXISTING DISPLAYS AND ASSOCIATED CABLING. REMOVE GATE POSITION DISPLAYS AND REPLACE WITH CELL NO. 3 LEVEL AND VOLUME.
- 4 EXISTING POND 001 PANEL IS LOCATED IN EXISTING PUMP HOUSE STATION.
- 5 USE EXISTING SPARE I/O WHERE AVAILABLE. TWO SLOTS ARE OPEN FOR ADDITIONAL CARDS IF NEEDED.
- 6 PROVIDE FOC PATCH CORD FOR CONNECTION TO NEW HYDRAULIC ACTUATOR CONTROL PANEL.



POND 001 EXPANSION

ISSUE RECORD

NO. BY PURPOSE DATE CKD

1 JK IFC 21NO17

SCALE

DATE JUNE 19, 2017

DRAWN BY: LP

CHECKED BY: AS

FAA AIP NO:

WORK BREAKDOWN NO.

DESIGN CONTRACT NO.

201418360

CONST. CONTRACT NO.

201418360 TASK 5

VOLUME NO.

1

SHEET TITLE  
POND 001  
PANEL  
ELEVATION

SHEET NO.

E3050

60 OF 61

CADD FILE NO.

10697A1000E3050

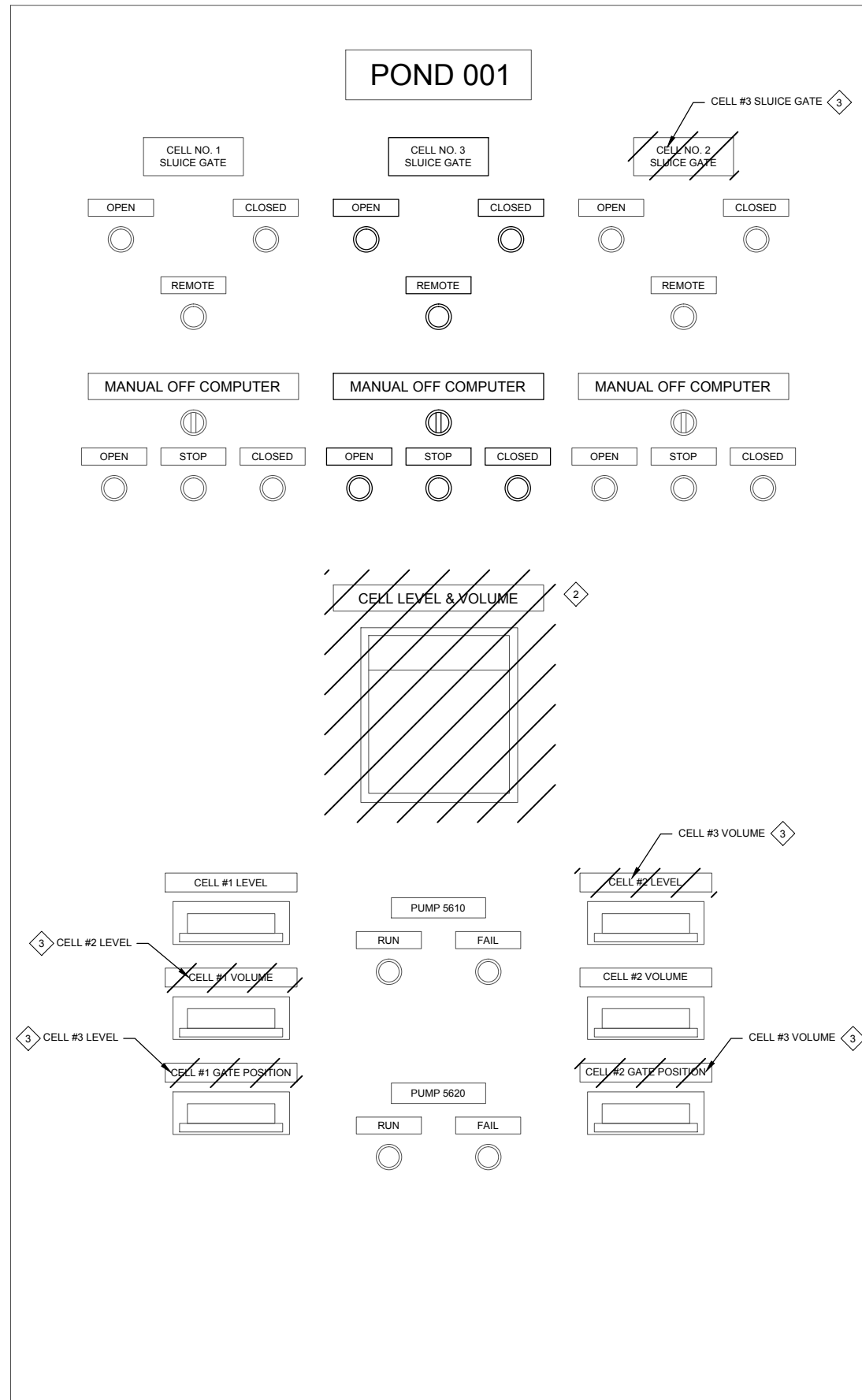

**A** PUMP HOUSE POND 001 PLC  
E1060

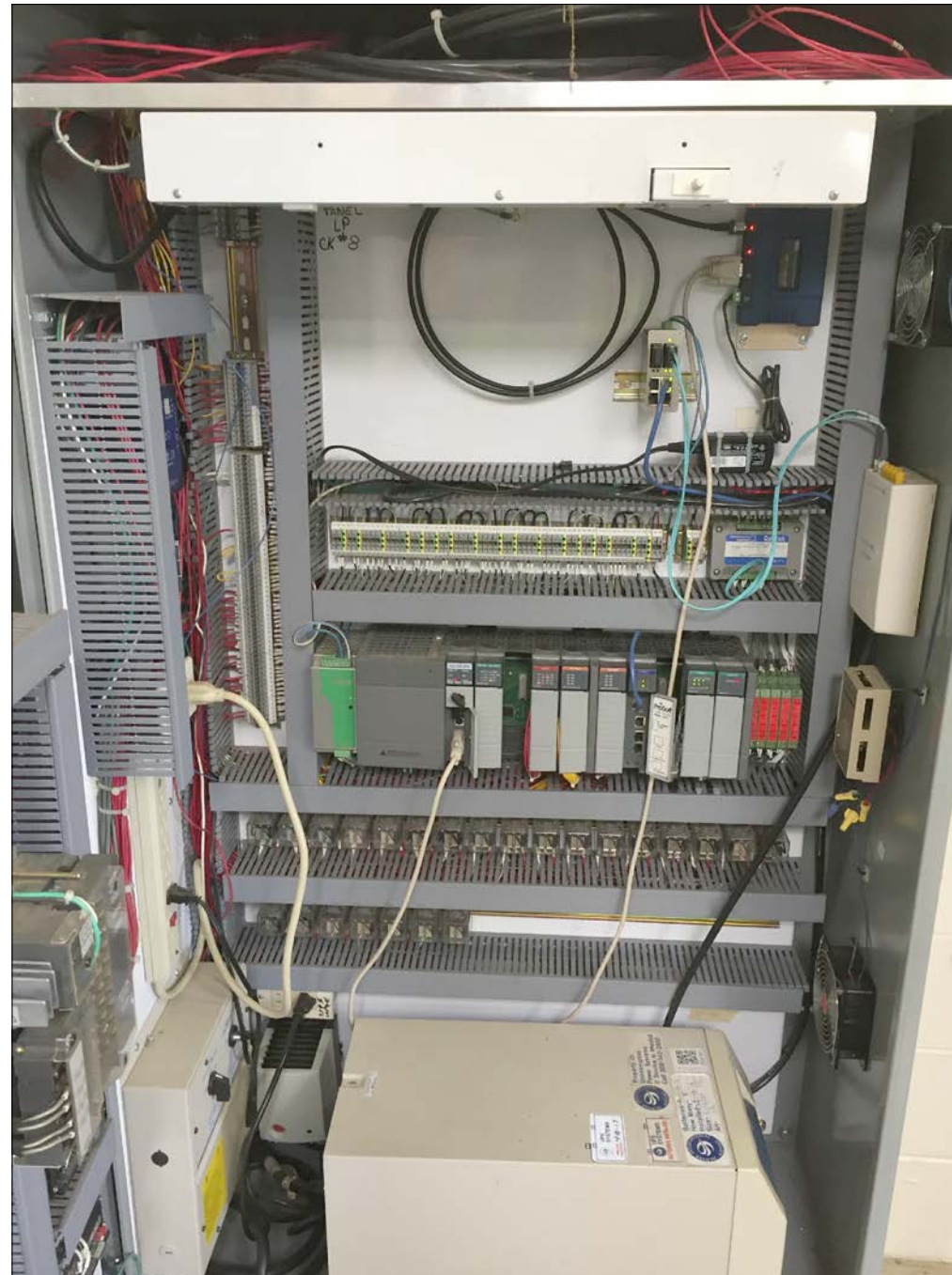

**B** PUMP HOUSE POND 001 PLC INTERIOR  
E1060

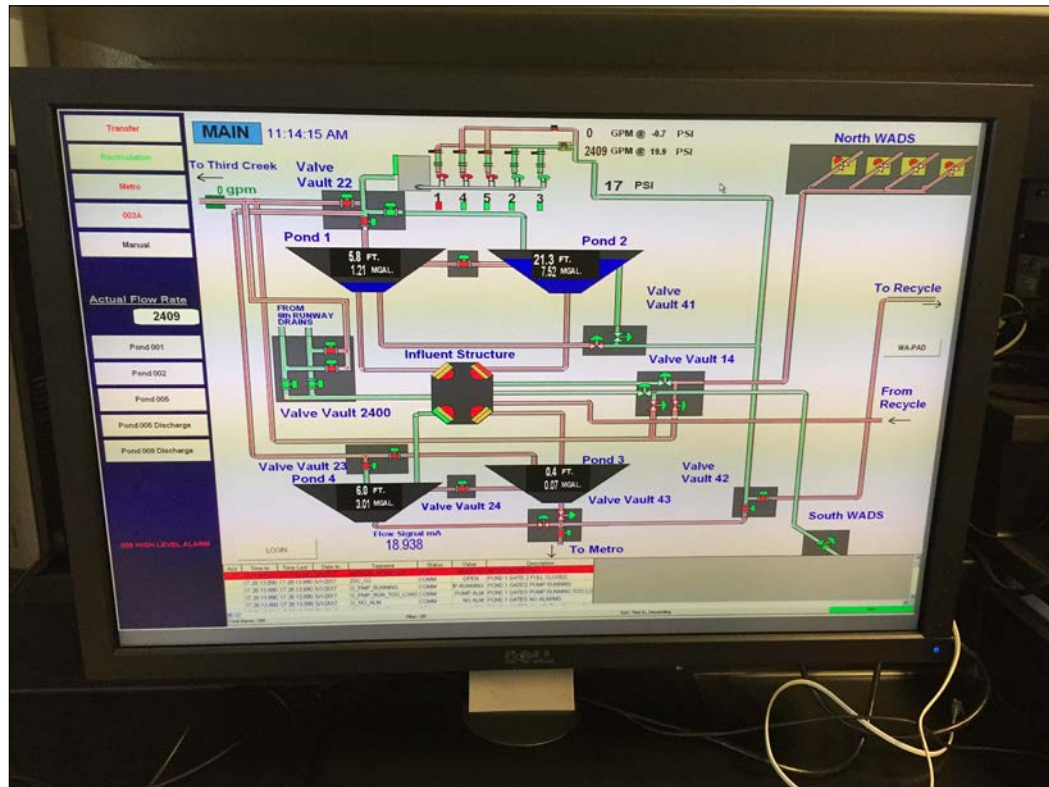

A MAIN POND SCREEN

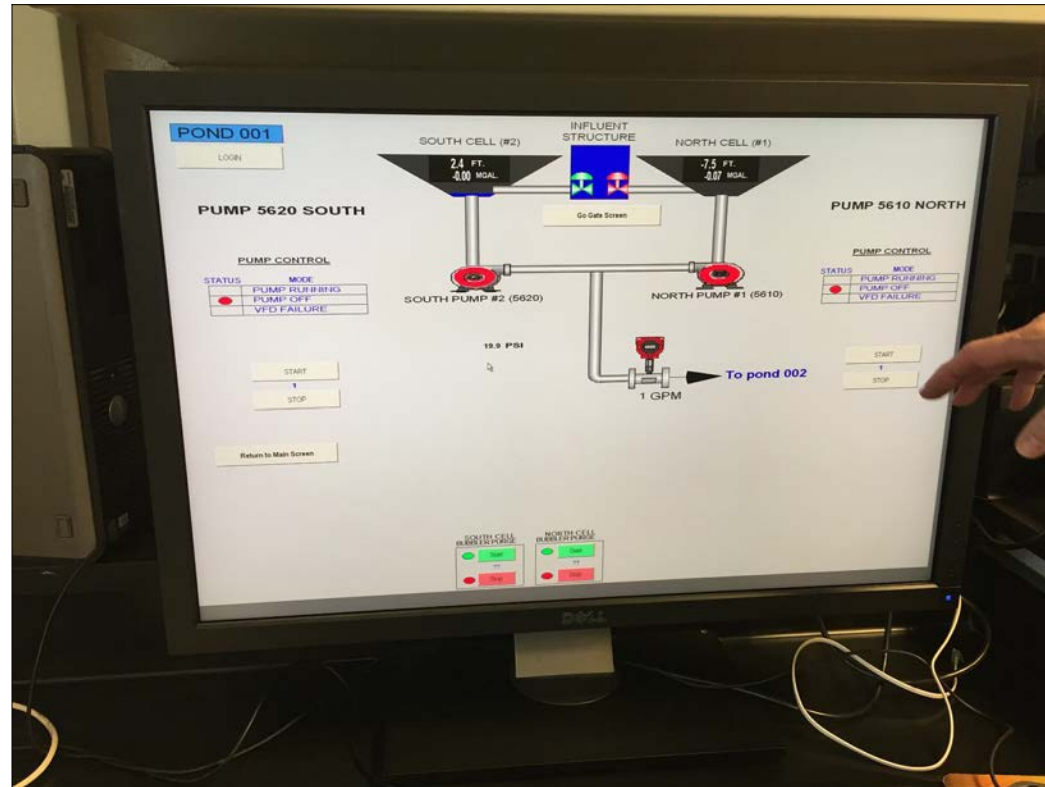

B POND 001 SCREEN

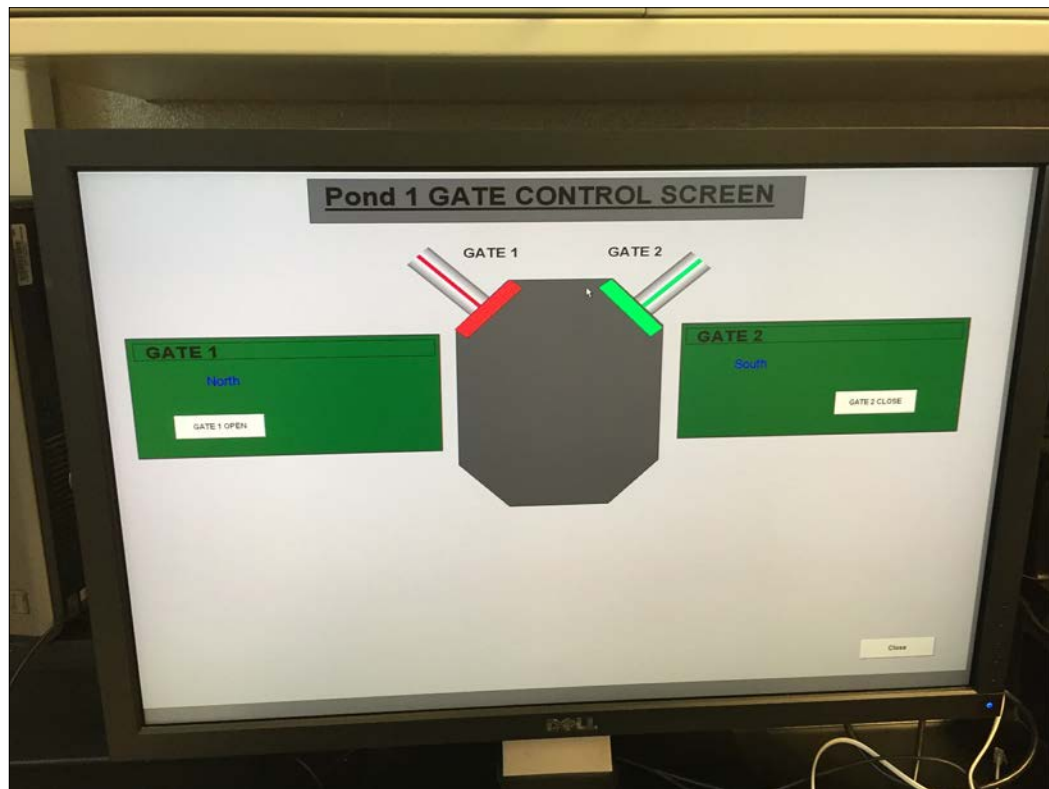

C POND 1 GATE CONTROL SCREEN

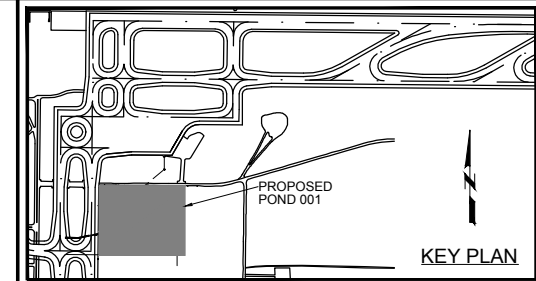

- GENERAL NOTES:
1. EACH OF THE EXISTING SCADA SCREENS NEED TO BE UPDATED WITH THE NEW CELL 3 GATE AND LEVEL CONTROL AND MONITORING TO MATCH EXISTING.



POND 001 EXPANSION

| NO. | BY | PURPOSE | DATE   | CHKD |
|-----|----|---------|--------|------|
| 1   | JK | IFC     | 21NO17 |      |

SCALE

DATE JUNE 19, 2017

DRAWN BY: LP

CHECKED BY: AS

FAA AIP NO:

WORK BREAKDOWN NO.

DESIGN CONTRACT NO. 201418360

CONST. CONTRACT NO. 201418360 TASK 5

VOLUME NO. 1

SHEET TITLE

SCADA SCREENS

SHEET NO.

E3060

61 OF 61

CADD FILE NO. 10697A1000E3060