



REQUEST FOR RESOLUTION FOR MAJOR ENCUMBRANCE PERMIT

TO: Karen Walton, City Attorney's Office
FROM: Robert J. Duncanson, P.E.
Manager 2, Development Engineering Services
ROW NO.: 2012-0095-01
DATE: April 17, 2012
SUBJECT: Request for a Resolution granting a revocable permit, subject to certain terms and conditions, to Three Chalets LLC, their successors and assigns, to encroach into the right-of-way with a 700 ft retaining stonewall at 1336 E 17th Ave.

It is requested that the above subject item be placed on the next available Mayor Council Agenda.

This office has investigated the request from Darren Carbary of Pasquini's Pizzeria Uptown/ dated 2/21/2012, on behalf of Three Chalets LLC for the granting of the above-subject permit.

This matter has been checked by this office and has been coordinated with Asset Management; Colorado Department of Transportation (if required); Comcast Corporation; Commission For People With Disabilities; Councilperson Albus Brooks; CPD: Building & Construction Services, Planning Services, and Zoning & Development Review; Denver Water Board; Environmental Services (if required); Fire Department (if required); Metro Wastewater Reclamation District; Office of Emergency Management; Office of Telecommunications; Parks and Recreation; Public Works: City Engineer, DES Construction Engineering, DES Engineering, DES Survey, IPP Infrastructure Engineering, and Street Maintenance; Qwest Corporation; Regional Transportation District; and Xcel Energy, all of whom have returned our questionnaires indicating their agreement.

As a result of the investigations, it has been determined that there is no objection to the granting of the revocable permit.

Therefore, you are requested to initiate Council action for the granting of a revocable permit, subject to certain terms and conditions, to Three Chalets LLC, their successors and assigns, to encroach with a 700 ft retaining stonewall at 1336 E 17th Ave.

INSERT PARCEL DESCRIPTION ROW 2012-0095-01-001 HERE



STANDARD PROVISIONS

The revocable permit ("Permit") granted by this resolution is expressly granted upon and subject to each and all of the following terms and conditions:

- (a) Permittee shall obtain a street occupancy permit from Public Works Permit Operations at 2000 West 3rd Avenue, 303.446.3759, and prior to commencing construction.
- (b) Permittee shall be responsible for obtaining all other permits and shall pay all costs that are necessary for installation and construction of items permitted herein.
- (c) If the Permittee intends to install any underground facilities in or near a public road, street, alley, right-of-way or utility easement, the Permittee shall join the Statewide Notification Association of Owners and Operators of Underground Facilities by contacting the Utility Notification Center of Colorado, 12600 West Colfax Ave, Suite B-310, Lakewood, Colorado, 80215 at 303.232.1991. Further, Permittee shall contact the Utility Notification Center at 1-800-922-1987 to locate underground facilities prior to commencing any work under this permit.
- (d) Permittee is fully responsible for any and all damages incurred to facilities of the Water Department and/or drainage facilities for water and sewage of the City and County of Denver due to activities authorized by the permit. Should the relocation or replacement of any drainage facilities for water and sewage of the City and County of Denver become necessary as determined by the Manager of Public Works, in the Manager's sole and absolute discretion, Permittee shall pay all cost and expense of the portion of the sewer affected by the permitted structure. The extent of the affected portion to be replaced and relocated by Permittee shall be determined by the Manager of Public Works. Any and all replacement or repair of facilities of the Water Department and/or drainage facilities for water and sewage of the City and County of Denver attributed to the Permittee shall be made by the Water Department and/or the City and County of Denver at the sole expense of the Permittee. In the event Permittee's facilities are damaged or destroyed due to the Water Department's or the City and County of Denver's repair, replacement and/or operation of its facilities, repairs will be made by Permittee at its sole expense. Permittee agrees to defend, indemnify and save the City harmless and to repair or pay for the repair of any and all damages to said sanitary sewer, or those damages resulting from the failure of the sewer to properly function as a result of the permitted structure.
- (e) Permittee shall comply with all requirements of affected utility companies and pay for all costs of removal, relocation, replacement or rearrangement of utility company facilities. Existing telephone facilities shall not be utilized, obstructed or disturbed.
- (f) All construction in, under, on or over the Encroachment Area shall be accomplished in accordance with the Building Code of the City and County of Denver. Plans and Specifications governing the construction of the Encroachments shall be approved by the Manager of Public Works and the Director of the Building Inspection Division prior to construction. Upon completion, a reproducible

copy of the exact location and dimensions of the Encroachments shall be filed with the Manager of Public Works.

- (g) The sidewalk and street/alley over the Encroachment Area shall be capable of withstanding an HS-20 loading in accordance with the latest AASHTO Specifications. The installations within the Encroachment Area shall be constructed so that the paved section of the street/alley can be widened without requiring additional structural modifications. The sidewalk shall be constructed so that it can be removed and replaced without affecting structures within the Encroachment Area.
- (h) Permittee shall pay all costs of construction and maintenance of the Encroachment. Upon revocation of the permit or upon abandonment, Permittee shall pay all costs of removing the Encroachment from the Encroachment Area, and return the Encroachment Area to its original condition under the supervision of the City Engineer.
- (i) Permittee shall remove and replace any and all street/alley paving, sidewalks, and curb and gutter, both inside the Encroachment Area and in the rights-of-way adjacent thereto, that become broken, damaged or unsightly during the course of construction. In the future, Permittee shall also remove, replace or repair any street/alley paving, sidewalks, and curb and gutter that become broken or damaged when, in the opinion of the City Engineer, the damage has been caused by the activity of the Permittee within the Encroachment Area. All repair work shall be accomplished without cost to the City and under the supervision of the City Engineer.
- (j) The City reserves the right to make an inspection of the Encroachments contained within the Encroachment Area. An annual fee, subject to change, of \$200.00 shall be assessed.
- (k) This revocable permit shall not operate or be construed to abridge, limit or restrict the City and County of Denver in exercising its right to make full use of the Encroachment Area and adjacent rights-of-way as public thoroughfares nor shall it operate to restrict the utility companies in exercising their rights to construct, remove, operate and maintain their facilities within the Encroachment Area and adjacent rights-of-way.
- (l) During the existence of the Encroachments and this permit, Permittee, its successors and assigns, at its expense, and without cost to the City and County of Denver, shall procure and maintain a single limit comprehensive general liability insurance policy with a limit of not less than \$500,000.00. All coverage's are to be arranged on an occurrence basis and include coverage for those hazards normally identified as X.C.U. during construction. The insurance coverage required herein constitutes a minimum requirement and such enumeration shall in no way be deemed to limit or lessen the liability of the Permittee, its successors or assigns, under the terms of this permit. All insurance coverage required herein shall be written in a form and by a company or companies approved by the Risk Manager of the City and County of Denver and authorized to do business in the State of Colorado. A certified copy of all such insurance policies shall be filed with the Manager of Public Works, and each such policy shall contain a statement therein or

endorsement thereon that it will not be canceled or materially changed without written notice, by registered mail, to the Manager of Public Works at least thirty (30) days prior to the effective date of the cancellation or material change. All such insurance policies shall be specifically endorsed to include all liability assumed by the Permittee hereunder and shall name the City and County of Denver as an additional insured.

- (m) Permittee shall comply with the provisions of Article IV (Prohibition of Discrimination in Employment, Housing and Commercial Space, Public Accommodations, Educational Institutions and Health and Welfare Services) of Chapter 28 (Human Rights) of the Revised Municipal Code of the City and County of Denver. The failure to comply with any such provision shall be a proper basis for revocation of this permit.
- (n) The right to revoke this permit is expressly reserved to the City and County of Denver.
- (o) Permittee shall agree to indemnify and always save the City and County of Denver harmless from all costs, claims or damages arising, either directly or indirectly, out of the rights and privileges granted by this permit.

SPECIAL CONDITIONS FOR THIS PERMIT

- (p) None

A map of the area is attached hereto.

RJD: bvs 

cc: Asset Management, Steve Wirth
City Council Office, Gretchen Williams
Councilperson Albus Brooks and Aides
Department of Law, Karen Aviles
Department of Law, Arlene Dykstra
Department of Law, Karen Walton
Public Works, Alba Castro
Public Works, Christine Downs
Public Works, Nancy Kuhn
Project File #: 2012-0095-01

Property Owner:
Three Chalets LLC
1336 E 17th Ave
Denver, CO 80218

Agent:
Darren Carbary
Pasquini's Pizzeria Uptown
1336 E 17th Ave
Denver, CO 80218

ORDINANCE/RESOLUTION REQUEST

Please email requests to Nancy Kuhn at
Nancy.Kuhn@denvergov.org by **NOON on Monday.**

**All fields must be completed.*
Incomplete request forms will be returned to sender which may cause a delay in processing.*

Date of Request: April 17, 2012

Please mark one: Bill Request or Resolution Request

1. Has your agency submitted this request in the last 12 months?

Yes No

If yes, please explain:

2. Title: (Include a concise, one sentence description – please include name of company or contractor and contract control number - that clearly indicates the type of request: grant acceptance, contract execution, amendment, municipal code change, supplemental request, etc.)

Request for a Resolution granting a revocable permit, subject to certain terms and conditions, to Three Chalets LLC, their successors and assigns, to encroach into the right-of-way with a 700 ft retaining stonewall at 1336 E 17th Ave.

3. Requesting Agency: PW Right of Way Engineering Services

4. Contact Person: (With actual knowledge of proposed ordinance/resolution.)

- Name: Beverly Van Slyke
- Phone: 720-865-3125
- Email: beverly.vanslyke@denvergov.org

5. Contact Person: (With actual knowledge of proposed ordinance/resolution who will present the item at Mayor-Council and who will be available for first and second reading, if necessary.)

- Name: Nancy Kuhn
- Phone: 720-865-8720
- Email: Nancy.Kuhn@denvergov.org

6. General description of proposed ordinance including contract scope of work if applicable:

To encroach into the right-of-way with a 700 ft retaining stonewall at 1336 E 17th Ave.

***Please complete the following fields: (Incomplete fields may result in a delay in processing. If a field is not applicable, please enter N/A for that field.)*

- a. Contract Control Number: N/A
- b. Duration: Permanent
- c. Location: 1336 E 17th Ave
- d. Affected Council District: Albus Brooks, District #8
- e. Benefits: N/A
- f. Costs: N/A

7. Is there any controversy surrounding this ordinance? (Groups or individuals who may have concerns about it?) Please explain.

NONE

To be completed by Mayor's Legislative Team:

SIRE Tracking Number: _____

Date Entered: _____



DENVER
THE MILE HIGH CITY

EXECUTIVE SUMMARY

Project Title: 2012-0095-01 MEP, 1336 E 17th Ave , Pasquini's Pizzeria Uptown

Description of Proposed Project: To encroach into the right of way with a 700 ft retaining stonewall for patio.

Explanation of why the public right-of-way must be utilized to accomplish the proposed project: Previous owner replaced and updated outdoor patio with a retaining stonewall. The current owner is submitting for an MEP to come into compliance for his restaurant and to be able to offer outdoor seating. The MEP is required for an existing retaining stonewall.

Has a Temp MEP been issued, and if so, what work is underway: No

What is the known duration of an MEP: Permanent

Will land be dedicated to the City if the vacation goes through: N/A

Will an easement be placed over a vacated area, and if so explain: N/A

Will an easement relinquishment be submitted at a later date:N/A

Additional information: N/A



Parcel Description

A parcel of land located in a portion of the 100 foot public right-of-way of 17th Avenue and the 80 foot public right-of-way Humboldt Street, lying adjacent to Lot 1, Block 27 Park Avenue Addition to Denver, being in the Southwest Quarter of Section 35, Township 3 South, Range 68 West of the 6th Principal Meridian, City and County of Denver, State of Colorado, more particularly described as follows:

COMMENCING at the Northwest Corner of said Lot 1, Block 27 being monumented with a found no.4 rebar with a illegible plastic cap, whence a found cut cross being the 21.75 foot offset to the west of the Northwest corner of Lot 38, Block 28, Park Avenue Addition to Denver bears S 89° 56' 00" E, a distance of 183.59 feet, with all bearings herein relative thereto; Thence along the Northerly line of said Lot 1, Block 27 S 89° 56' 00" E, a distance of 83.29 feet and the **POINT OF BEGINNING**;

Thence N 00°04'00" E, a distance of 16.50 feet; Thence S 89°56'00" E, a distance of 54.00 feet; Thence S 00°04'00" W, a distance of 34.50 feet; Thence N 89°56'00" W, a distance of 12.00 feet; Thence N 00°04'00" E, a distance of 18.00 feet; Thence N 89°56'00" W, a distance of 42.00 feet to the **POINT OF BEGINNING**;

The above description contains 1,107.00 Square Feet more or less.

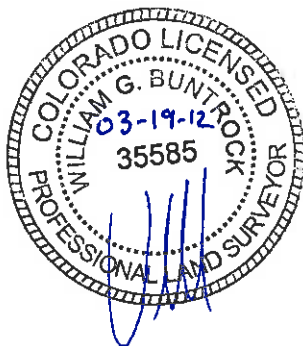

William G Buntrock, PLS
Colorado Licensed Land Surveyor No. 35585
TRUE NORTH Surveying & Mapping, LLC
303-484-8886
TN 12013

EXHIBIT A

Page 2 of 2

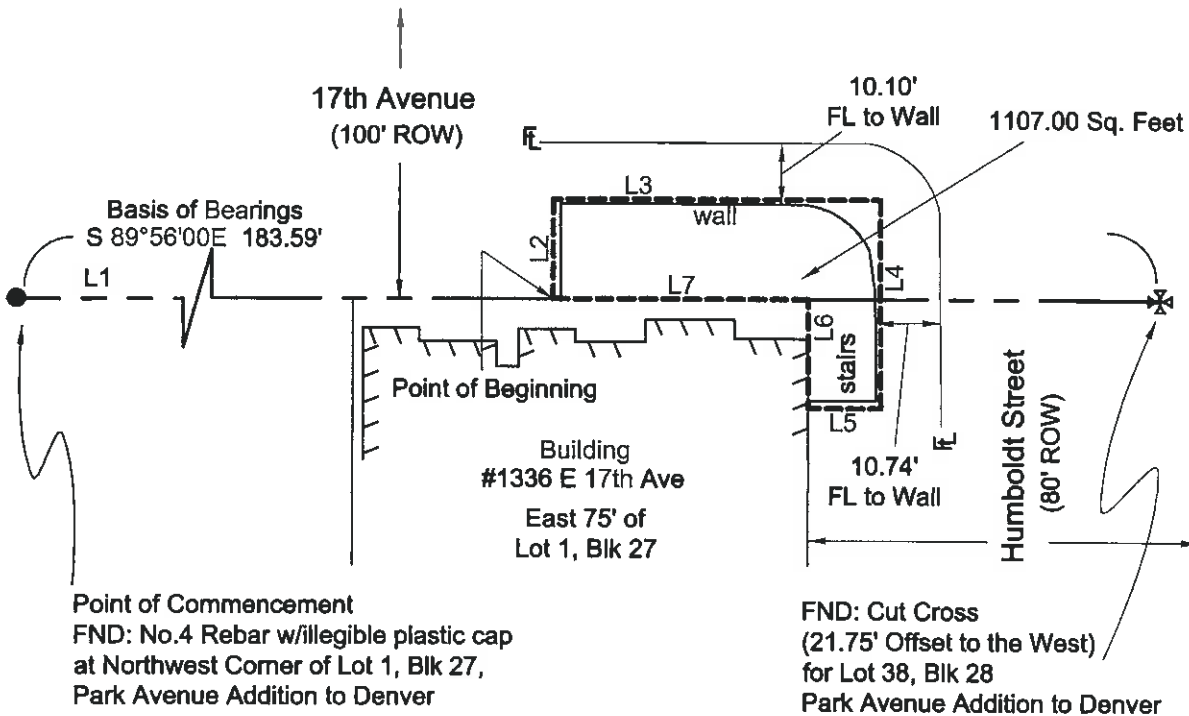

Point of Commencement
 FND: No.4 Rebar w/illegible plastic cap
 at Northwest Corner of Lot 1, Blk 27,
 Park Avenue Addition to Denver

FND: Cut Cross
 (21.75' Offset to the West)
 for Lot 38, Blk 28
 Park Avenue Addition to Denver

LINE	BEARING	DISTANCE
L1	S 89°56'00" E	83.29'
L2	N 00°04'00" E	16.50'
L3	S 89°56'00" E	54.00'
L4	S 00°04'00" W	34.50'
L5	N 89°56'00" W	12.00'
L6	N 00°04'00" E	18.00'
L7	N 89°56'00" W	42.00'



NOTE: THIS EXHIBIT DOES NOT REPRESENT A MONUMENTED LAND SURVEY. IT IS INTENDED ONLY TO DEPICT THE ATTACHED DESCRIPTION.



DATE	02/24/12
DRAWN	BB
CHECKED	BB
APPROVED	BB
PROJECT NO.	TN 12013
HORZ. SCALE	1" = 30'

NOTICE - According to Colorado law you must commence any legal action based upon any defect in this survey within three years after you first discover such defect. In no event may any action based upon any defect in this survey be commenced more than ten years from the date of the certification shown hereon.