



ELEVATOR, ESCALATOR, AND WALKWAY MODERNIZATION: Thyssenkrupp Elevator Corporation

MARCH 3, 2021

SANDRA SCANLON, SR DIRECTOR
AIM DEVELOPMENT



Current contract awarded to Thyssenkrupp Elevator Corporation (TKE) in 2018

- Competitive RFP
- \$10 million contract capacity
- Five-year contract
- MWBE Goal 8%
- 8% MWBE goal is currently being achieved:
 - Tier 1: Reliant Construction and Gilmore Construction – MBE (project management, building modifications, permit procurement, general contracting, finish work)
 - Tier 2: Freeman Signs – WBE (graphics installer)
- TKE has performed well and is delivering on-time and on-budget

CONTRACT BEFORE YOU TODAY



Competitively procured – TKE was the successful proposer

- \$40 million contract capacity
- Five-year contract
- TKE selected based upon continuity of service, institutional knowledge gained from 1st contract, synergy with DEN project team, and proposal responsiveness
- MWBE Goal 8%
 - 8% MWBE participation includes the labor and materials from the following subs:
 - Tier 1: Reliant Construction – MBE (project management, building modifications, permit procurement, general contracting, finish work)
 - Tier 2: Freeman Signs – WBE (graphics installer)
 - Majority of elevator/escalator/walkway equipment is manufactured and provided by the prime contractor

Scope of Work:

- Modernizes ~70 elevators, escalators and moving walkways
- Provides two-way communication and elevator status panel systems to meet building code and improved operations
- Installs enhanced monitoring systems to track down-time in real time
- Continues to address the next group of high priority units (elevators, escalators, and moving walks) at the end of their life cycle
- Includes project management, design, supervision, administration, labor, tools, materials and equipment

Modernization means:

- Replaces of all mechanical parts subject to “wear and tear”
- Re-uses structural components/shell
- Upgrades system components for efficiency, safety, monitoring, and control
- Improves the appearance and interface for passengers

EXAMPLE ESCALATOR MODERNIZATION

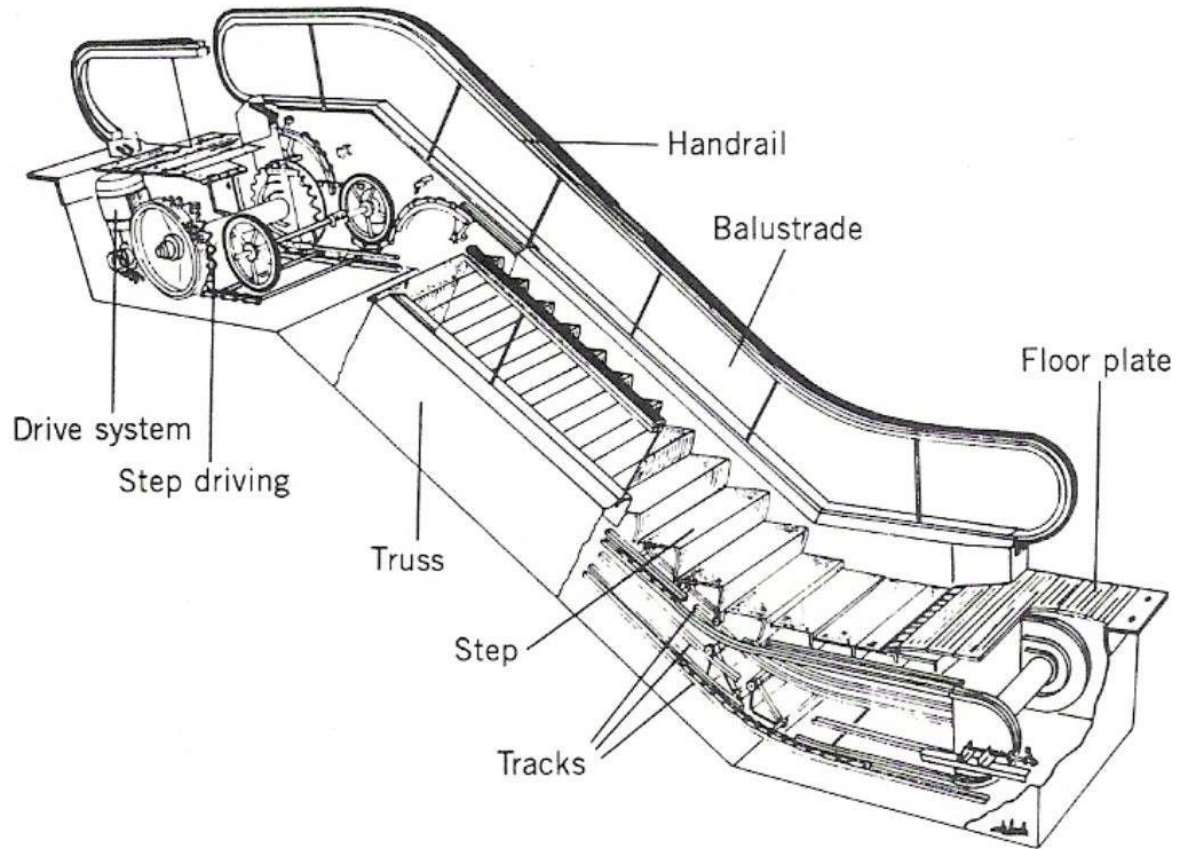

Components of a typical escalator

EXAMPLE ESCALATOR MODERNIZATION

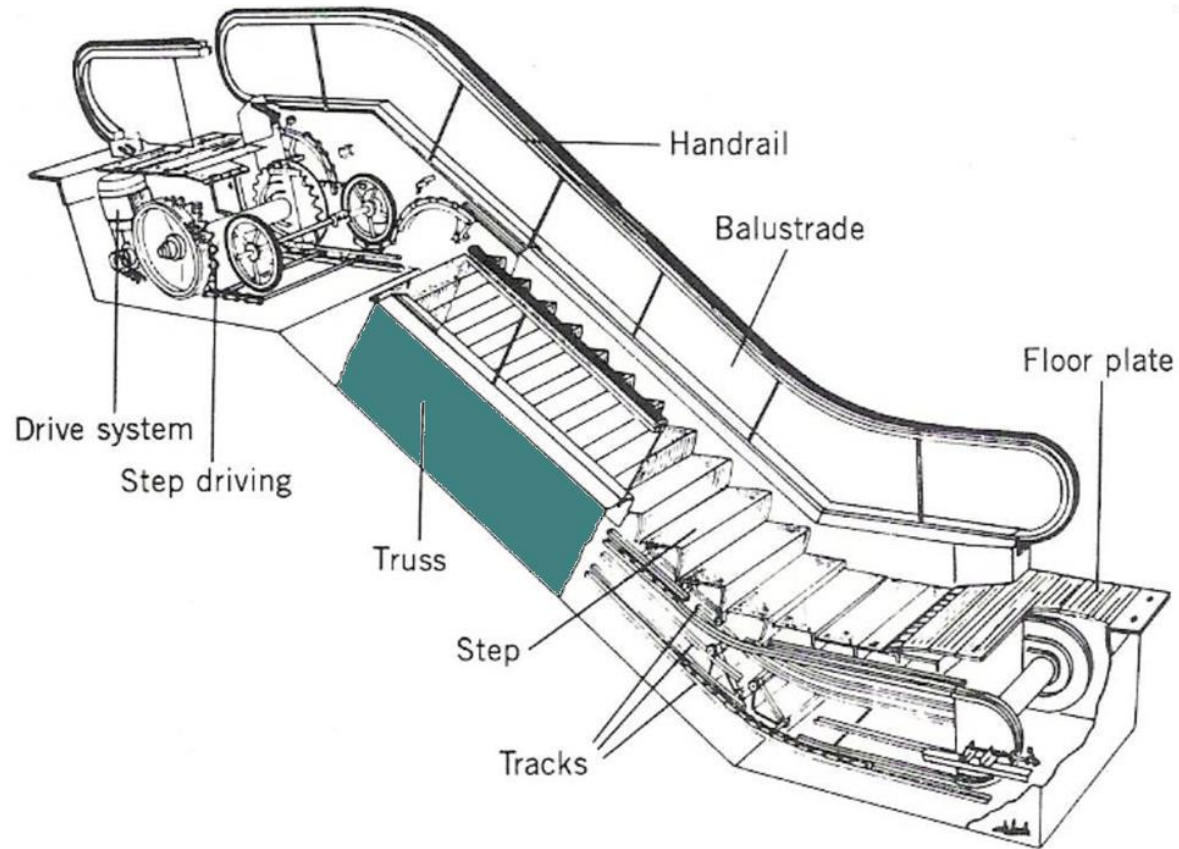

All items except the Truss (structural steel) are replaced and updated

WALKWAY MODERNIZATION PROCESS



Removing Old Walkway

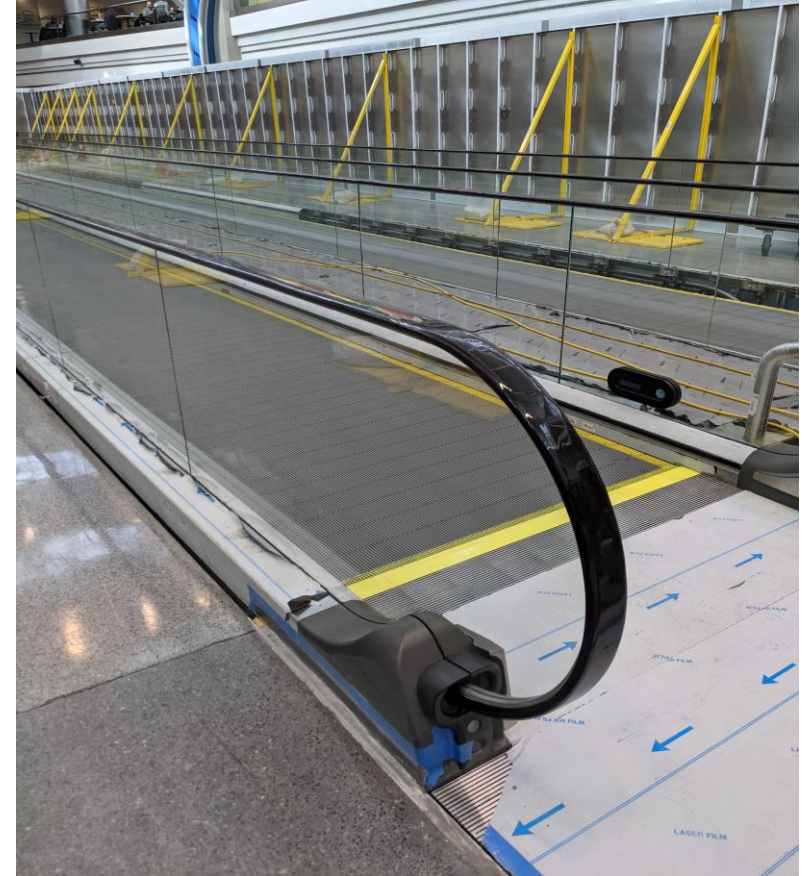

Newly installed Moving Walk

ANTICIPATED SCHEDULED



	Year 2021				Year 2022				Year 2023				Year 2024				Year 2025			
TASK ORDERS – CURRENT PLAN	Q1	Q2	Q3	Q4	Q1	Q2	Q3	Q4	Q1	Q2	Q3	Q4	Q1	Q2	Q3	Q4	Q1	Q2	Q3	Q4
Task Order #1 - 12 units @ Passenger Train Terminal Arrival Station					\$6.4 M															
Task Order #2 - 6 Elevators International Area			\$2.4 M																	
Task Order #3 - 8 Concourse B Escalators											\$4.8 M									
Task Order #4 - 8 Concourse C Elevators			\$3.2 M																	
Task Order #5 - 8 Terminal Escalators													\$5 M							
Task Order #6 - 9 Concourse A Elevators													\$3.6 M							
Task Order #7 - 4 Concourse A Moving Walkways													\$3.5 M							
Task Order #8 - 6 Concourse B Elevators					\$2.4 M															
Task Order #9 - 8 Terminal Freight Elevators									\$3.2 M											
~70 conveyance units modernized																				

Estimated schedule and budget will allow flexibility if equipment priorities shift

MODERNIZATION CRITERIA



Age of unit, downtime of the unit & maintenance required to fix



Prioritized in an order to best fit needs and operations of DEN



Modernize units based on contractor labor capacity and availability



QUESTIONS?