

**INTERGOVERNMENTAL AGREEMENT
(Hampden Heights Water Quality Facility)**

This intergovernmental agreement (“Agreement”) is made and entered by and between the **CITY AND COUNTY OF DENVER** (“Denver”), a municipal corporation of the State of Colorado and **SCHOOL DISTRICT NO. 1 IN THE CITY AND COUNTY OF DENVER AND THE STATE OF COLORADO**, hereinafter referred to as the “School District”.

RECITALS

WHEREAS, School District has secured funding to construct a water quality facility near the intersection of South Havana Street and East Dartmouth Avenue and adjacent to Cherry Creek on property owned by Denver and the School District as detailed in this Agreement (“Hampden Heights Water Quality Facility Project”); and

WHEREAS, Denver has agreed to contribute funding for the construction of the Hampden Heights Water Quality Facility Project as detailed below; and

WHEREAS, School District will construct the Hampden Heights Water Quality Facility Project in conformity with the terms of this agreement;

WHEREAS, the City and the School District agree that the Project will serve and benefit the citizens of the City and County of Denver by creating an improvement to storm drainage that would be superior to each party independently pursuing its own storm drainage project.

NOW, THEREFORE, in consideration of the recitals stated above and the terms and conditions of the Agreement set forth below, Denver and School District agree as follows:

1. Purpose: The purpose of this Agreement is to define the Hampden Heights Water Quality Facility Project, specify the terms and requirements applicable to construction of the project, provide for Denver’s payment of a portion of the costs School District will incur constructing the project, specify maintenance of the project, and define property transfers upon completion of the project.

2. The Hampden Heights Water Quality Facility Project: The Hampden Heights Water Quality Facility Project includes all planning, design, construction, labor, management, administration, supervision, materials, supplies, manufactured components, equipment, easements, fees, permits, taxes and all other materials or services necessary to complete the improvements shown in the plans and specifications attached as **Exhibit A**.

3. Assignment: Pursuant to the authority granted in Section 2.3.3(A) of the Denver Charter, the Mayor hereby assigns to School District, the design, planning, and construction of the Hampden Heights Water Quality Facility Project, including the qualification, selection and retention of all consultants, designers and contractors engaged in connection therewith.

4. Representatives:

(a) Denver's Executive Directors of Public Works and Parks and Recreation (the "**Executive Directors**") are vested with the authority to act on behalf of Denver in performing Denver's obligations under this Agreement. The Executive Directors may designate certain person(s) to act on the Executive Directors' behalf as the authorized representative(s). A Manager may change its authorized representative(s) at any time by providing written notice to School District of such change.

(b) Trena A. Deane, Executive Director of Facility Management or her designated representative is School District's authorized representative under this Agreement and, as such, is responsible for overseeing the completion of the Hampden Heights Water Quality Facility Project, in accordance with the terms and conditions of this Agreement. School District may change its authorized representative at any time by providing written notice to the Executive Directors of Public Works and Parks and Recreation of such change.

5. School District's Responsibilities:

(a) School District shall have sole responsibility with respect to undertaking, completing and raising all of the required funds for the Hampden Heights Water Quality Facility Project with the exception of Denver's contribution as specified in this agreement.

(b) School District shall be responsible for the selection and retention of all contractors and consultants necessary to complete the Hampden Heights Water Quality Facility Project. All contractors and consultants shall be qualified and licensed at a minimum per Denver requirements.

(c) School District and Denver do not anticipate changes to the Hampden Heights Water Quality Facility Project as detailed in **Exhibit A**. In the event that changes are required, School District will submit revised plans and/or specification for the Executive Directors' written approval before making any change. Denver agrees to expedite its review of proposed changes and work with School District to resolve any disagreements about proposed changes.

(d) School District shall at all reasonable hours provide right of entry to any Denver inspector or other authorized agent of Denver to the work site to inspect the work site and progress of the Hampden Heights Water Quality Facility Project and to conduct tests and evaluations to determine that the work performed and materials used are of good quality and in conformance with the approved plans and specifications.

(e) Denver will not charge School District for Denver's review of plans or for inspections, material testing, and construction monitoring that Denver elects to perform. Any testing, inspection or monitoring by Denver will not relieve School District of responsibility to construct the Hampden Heights Water Quality Facility Project in conformance with approved plans and specifications. Standard building, erosion control, flood plain, street occupancy, street cut, and other regulatory fees mandated by existing ordinance or rule for construction approvals will be paid by School District.

(f) School District shall be solely responsible for assuring that all phases of the Hampden Heights Water Quality Facility Project are properly contracted and performed and that the work done and the materials used are in conformance with all applicable laws (local, state, and federal) that govern the performance of the work, including the requirements of the federal Americans with Disabilities Act and any other federal or state laws requiring access for the disabled to public accommodations, the Colorado Department of Public Health and Environment, the State of Colorado, or the US Army Corps.

(g) In addition to compliance with the above-mentioned laws, School District shall be governed and controlled by all limitations and provisions that are imposed on the Denver Department of Public Works by the Charter or ordinances of Denver. Specifically, such work shall be performed in compliance with the provisions for payment of prevailing wages set forth in Sections 20-76 through 20-79 of the Denver Revised Municipal Code ("DRMC"), the provisions for small business enterprise, equal employment opportunity, and minority and women business enterprise participation that are contained in Sections 28-31 through 28-91, DRMC, any state and local laws requiring performance and payment bonds (which will name Denver as an obligee), and for deducting and retaining a total of five percent (5%) from the total amount of approved payment applications until at least 95% of the work is complete.

(h) School District agrees that any duly authorized representative of the City, including the City Auditor or his representative, shall, until the expiration of three (3) years after

the final payment under this Agreement, have access to and the right to examine any directly pertinent books, documents, papers and records in School District's possession, involving transactions related to this Agreement.

(i) School District shall ensure that all contractors and sub-contractors obtain and maintain insurance coverage of the types and with the limits specified in attached **Exhibit B**. School District will ensure that all contractors and subcontractors comply with the insurance requirements specified in **Exhibit B** including naming Denver as an additional insured for all insurance coverage, except professional liability and workers' compensation. In addition, School District will ensure that all agreements with contractors and sub-contractors include an indemnification and "hold harmless" provision naming Denver that includes the language in **Exhibit B**.

(j) All performance and payment bonds must be conditioned upon (1) the contractor promptly making payment of all amounts lawfully due to all subcontractors, persons or entities furnishing labor or materials used in the Hampden Heights Water Quality Facility Project, and (2) so as to guarantee the contractor's completion of the Hampden Heights Water Quality Facility Project.

(k) School District shall obtain a minimum one (1) year warranty for plants and three year warranty for all other elements from the date Denver accepts the Hampden Heights Water Quality Facility Project on all labor and materials. Denver shall be the primary beneficiary of all warranties and guarantees. School District shall cooperate with Denver in inspections or warranty investigations during the warranty period, and support Denver if Denver decides to enforce any warranty. The obligations set out in this subparagraph shall survive the termination of this Agreement.

(l) School District shall promptly pay when due all bills, debts and obligations incurred in connection with this Agreement and shall not permit the same to become delinquent.

(m) School District shall obtain all federal, state, and local environmental permits necessary for the work to be performed and shall comply with all applicable federal, state, and local environmental permit requirements applicable to the work. School District shall comply with all applicable local, state, and federal environmental guidelines, rules, regulations, statutes, laws, and orders applicable to the work, including but not limited to Environmental

Requirements regarding the storage, use, transportation, and disposal of Hazardous Materials and regarding releases or threatened releases of Hazardous Materials to the environment. The term “**Hazardous Materials**” shall mean asbestos, asbestos contaminated soils, and asbestos-containing materials, special wastes, polychlorinated biphenyls (PCBs), any petroleum products, natural gas, radioactive source material, pesticides, any hazardous waste as defined at 42 U.S.C. § 6903(5) of the Solid Waste Disposal Act, any hazardous substance as defined at 42 U.S.C. § 9601(14) of the Comprehensive Environmental Response, Compensation and Liability Act, and chemical substance as defined at 15 U.S.C. § 2602(2) of the Toxic Substances Control Act, and any guidelines issued and rules or regulations promulgated pursuant to such statutes, or any other applicable federal or state statute.

(n) School District shall take all reasonable measures to minimize and control noise, water and air pollution, water discharges, and soil erosion resulting from work and activities associated with the Hampden Heights Water Quality Facility Project and to avoid adverse impacts to the surrounding parks or trails.

(o) School District will minimize impacts to the existing trail and trail users. Trail closures or detours will not be allowed without prior review written approval by the Executive Director of Parks and Recreation. School District will obtain approval for any sidewalk, road or lane closures by Denver’s Public Works Traffic Engineering Services Department. School District will maintain the trails and provide access to the trails.

(p) In the event of any material default or breach by any contractor or subcontractor School District agrees to diligently undertake and pursue all available remedies against the breaching or defaulting party, and to timely advise Denver as to efforts and progress made by School District in this regard and to allow for Denver’s participation, if Denver so requests.

(q) School District and its contractors and subcontractors shall pay all applicable taxes, including sales and use taxes and occupational privilege taxes, levied by the State and Denver on any tangible property built into or incorporated into the work. Upon request by Denver, an itemized and certified statement, including the names and addresses of the suppliers, the amount of such taxes owed or paid, and the dates of payment, shall be furnished to Denver.

(r) School District shall ensure that all improvements are constructed in accordance with the **Exhibit A** and that no material changes occur during construction, unless approved in advance and in writing by the Manager of Parks and Recreation and the Manager of Public Works or their designated representatives.

(s) School District shall provide the Manager of Parks and Recreation and the Manager of Public Works with written notification of substantial completion in order that Denver may participate in all punch list reviews and sign off on the improvements. School District shall provide the Manager of Parks and Recreation and the Manager of Public Works with written notification of final completion in order that Denver may inspect the improvements as constructed and verify that the improvements have been constructed in accordance with this Agreement without any material deviations, and the work is at final completion. Upon determination that the requirements set forth in this Agreement have been satisfied, the Executive Directors shall jointly issue a written letter accepting the improvements. Detailed and State of Colorado Professional Engineer stamped “as built” construction plans and any operation, maintenance, or warranty documents will be provided to the Manager of Parks and Recreation and the Manager of Public Works within sixty (60) days following Denver’s final inspection.

(t) School District agrees to comply with all applicable laws concerning non-discrimination against persons because of their race, color, religion, national origin, gender, age, military status, sexual orientation, marital status, or physical or mental disability in connection with the Hampden Heights Water Quality Facility Project.

(u) Notwithstanding any provision of this Agreement to the contrary, any financial obligation of School District is contingent upon all funds necessary for performance being budgeted, appropriated or otherwise made available. The Parties acknowledge that this Agreement does not create a multiple-fiscal year direct or indirect debt or financial obligation.

6. **Denver’s Responsibilities.**

(a) School District agrees to accept, and Denver agrees to pay, as full and complete compensation for completion of all items of work for the Hampden Heights Water Quality Facility Project described herein the sum of two thirds of the construction contract value plus any approved change orders for the Project (Denver’s Share). In no event shall Denver’s total contribution herein exceed Nine Hundred Eighty One Thousand Six Hundred Fifty Nine Dollars and Twenty Cents (\$981,659.20). It is understood and agreed that any payment or

performance obligation of Denver or School District hereunder, whether direct or contingent, shall extend only to utilization of funds appropriated by the Denver City Council and the School District for the purpose of this Agreement, encumbered for the purpose of the Agreement and paid into the Treasury or the designated financial department of each respective party. The parties acknowledge that (i) neither party does by this Agreement irrevocably pledge present cash reserves for payments in future fiscal years, and (ii) this Agreement is not intended to create a multiple-fiscal year direct or indirect debt or financial obligation of either party.

(b) At no point will Denver's total payment obligation exceed 90% (\$883,493.28) of the total committed amount of \$981,659.20 until written approval of Final Completion is issued by the Executive Directors per paragraph 5(s) above. Once Final Completion is reached and written approval is issued by Denver, School District may invoice Denver for either the remaining 10% balance of \$98,165.92, or the remaining amount of obligated funds, whichever is greater.

(c) School District shall notify Denver when substantial completion is achieved and give Denver a reasonable amount of time to inspect the project and submit punch list items. School District will then notify Denver when final completion is achieved. Once Denver has been notified of, and verified, final completion, received stamped as-built plans and all warranty documents Denver will notify School District of its acceptance of the improvements. Upon acceptance Denver will assume responsibility for maintenance and repair of the Hampden Heights Water Quality Facility Project. After Denver accepts the Hampden Heights Water Quality Facility Project School District will have no ongoing maintenance responsibilities. Additionally, after acceptance the parties will execute the necessary documents to convey to Denver the parcels of land currently owned by School District which underlies a portion of the Hampden Heights Water Quality Facility Project. The legal descriptions for the parcel(s) of land referenced above are attached hereto as **Exhibit C** and will also be utilized for the correction deed contemplated by and referenced in the Quit Claim Deed from Denver to the School District for the Hampden Heights Property dated July 8, 2013, and recorded July 10, 2013 in the records of the Denver Clerk and Recorder at Reception No. 2013100201.

(d) Denver shall grant School District rights to use the Hampden Heights Water Quality Facility for educational purposes and for School District's water quality requirements.

(e) Notwithstanding any provision of this Agreement to the contrary, any financial obligation of Denver herein is contingent upon all funds necessary for performance being budgeted, appropriated and otherwise made available. The Parties acknowledge that this Agreement does not create a multiple-fiscal year direct or indirect debt or financial obligation of Denver.

7. **Governmental Immunity.** Nothing in the Agreement shall be construed as a waiver of the notice requirements, defenses, immunities and limitations of liability Denver or School District may have under the Colorado Governmental Immunity Act (§24-10-101, C.R.S., et. seq.) or to any other defenses, immunities, or limitations of liability available by law.

8. **General Provisions.**

(a) **Governing Law; Venue.** This Agreement shall be construed and enforced in accordance with the laws of the United States, the State of Colorado, and the applicable provisions of the Charter and Revised Municipal Code of the City and County of Denver. Venue for any legal action relating to the Agreement shall lie in the District Court in and for the City and County of Denver.

(b) **Conflict of Interest.** The Parties agree that no official, officer or employee of Denver shall have any personal or beneficial interest whatsoever in the services or property described herein, and School District further agrees not to hire or contract for services any official, officer or employee of Denver or any other person which would be in violation of Denver Revised Municipal Code Chapter 2, Article IV, Code of Ethics, or Denver City Charter provisions 1.2.9 and 1.2.12.

(c) **No Personal Liability.** No official, officer, director, agent, or employee of either Party shall be charged personally or held contractually liable to the other Party or its officials, officers, directors, agents, or employees under any term or condition of this Agreement or for any breach, default, or violation under the Agreement.

(d) **No Third Party Beneficiaries.** It is expressly understood and agreed that enforcement of the terms and conditions of this Agreement, and all rights of action relating to such enforcement, shall be strictly reserved to the parties; and nothing contained herein shall give or allow any such claim or right of action by any other or third person on such agreements. It is the express intention of the parties that any person or entity other than the parties receiving benefits under this Agreement shall be deemed to be an incidental beneficiary only.

(l) Notices. All notices, demands or consents required or permitted under the Agreement shall be in writing and shall be deemed delivered upon receipt, if delivered personally or by facsimile transmission (receipt verified by telephone), or upon the third day following posting by certified mail, return receipt requested, to the following addresses:

If to the School District:

Superintendent
Denver Public Schools
1860 Lincoln Street
Denver, Colorado 80203

Executive Director of Facility Management
Denver Public Schools'
2800 West Seventh Avenue
Denver, Colorado 80204

cc: General Counsel
Denver Public Schools
1860 Lincoln Street
Denver, Colorado 80203

If to Denver or the Executive Directors:

Executive Director of Parks and Recreation
City and County of Denver
201 West Colfax Avenue, Dept. 601
Denver, Colorado 80202

Executive Director of Public Works
City and County of Denver
201 West Colfax Avenue, Dept. 608
Denver, Colorado 80202

cc: Denver City Attorney
1437 Bannock Street, Room 353
Denver, Colorado 80202

The address for any party set forth above may be changed at any time by written notice in the manner provided herein to the parties.

(m) Entire Agreement. This Agreement, including the exhibits which are hereby incorporated into this agreement by reference, constitutes the entire agreement of the parties. The parties agree there have been no representations, oral or written, other than those

contained herein and that the various terms and conditions contained herein are mutually agreed upon and are in consideration for one another.

(n) Amendment. This Agreement can only be amended, modified, or changed, in whole or in part, by written agreement executed by the parties in the same manner as this agreement.

(o) Severability. Should any one or more provisions of this Agreement be determined to be illegal or unenforceable by a court of competent jurisdiction, all other provisions of this Agreement nevertheless shall remain effective; provided, however, the parties shall forthwith enter into good faith negotiations and proceed with due diligence to draft a term or condition that will legally achieve the original intent and purposes of the parties hereunder.

(p) No Construction against Drafting Party. The parties acknowledge that each of them and their respective counsel have had the opportunity to review this Agreement and that this Agreement shall not be construed against any party merely because this Agreement or any of its provisions have been prepared by a particular party.

(q) Counterparts. This Agreement may be executed in counterparts, each of which shall be deemed an original, but all of which together shall constitute one Agreement.

(r) Electronic Signatures and Electronic Records. School District consents to the use of electronic signatures by Denver. The Agreement, and any other documents requiring a signature hereunder, may be signed electronically by Denver in the manner specified by Denver. The parties agree not to deny the legal effect or enforceability of the Agreement solely because it is in electronic form or because an electronic record was used in its formation. The parties agree not to object to the admissibility of the Agreement in the form of an electronic record, or a paper copy of an electronic document, or a paper copy of a document bearing an electronic signature, on the ground that it is an electronic record or electronic signature or that it is not in its original form or is not an original.

Contract Control Number: PWADM-201523827-00

Contractor Name: School District No. 1 in the City and County of Denver and the State of Colorado

By: David A. Suppes

Name: David A. Suppes
(please print)

Approved as to form: [Signature]
General Counsel
Denver Public Schools

Title: COO
(please print)

ATTEST: [if required]

By: Ramona Lewis

Name: Ramona Lewis
(please print)

Title: Board Liaison / Notary Public
(please print)

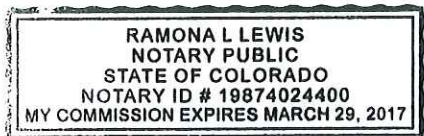

Contract Control Number:

IN WITNESS WHEREOF, the parties have set their hands and affixed their seals at Denver, Colorado as of

SEAL

CITY AND COUNTY OF DENVER

ATTEST:

By _____

APPROVED AS TO FORM:

REGISTERED AND COUNTERSIGNED:

By _____

By _____

By _____



EXHIBIT A

GENERAL NOTES:

- 1. CONTRACTORS PERFORMING WORK ON ANY WASTEWATER FACILITY OR APPURTENANCE MUST BE PROPERLY LICENSED AND HAVE A LICENSED PLUMBER OR DRAINLAYER ON SITE DURING THE WORK.
2. THE MOST RECENT EDITION OF THE WASTEWATER MANAGEMENT DIVISION STANDARD DETAILS AND TECHNICAL SPECIFICATIONS APPLY TO ALL WORK.
3. THE CONSTRUCTION ACTIVITIES STORMWATER DISCHARGE PERMITS (STATE AND LOCAL), STREET-CUT PERMIT, AND STREET OCCUPANCY PERMIT...
4. A PARKS AND RECREATION PERMIT WILL BE REQUIRED FOR ANY WORK OR OCCUPANCY OF PARK LAND, THIS INCLUDES BUT IS NOT LIMITED TO: DESIGNATED CITY PARKS, PARKWAYS, OPEN SPACE, TRAILS AND BIKE PATHS.
5. ALL DESIGN DRAWINGS PROVIDED AS PART OF THIS CONTRACT ARE FORMATTED FOR PRINTING FULL SIZE, ON STANDARD 22 X 34 INCH (ANSI D) PAPER SIZE AND TO HALF-SIZE (AND SCALE WHERE APPROPRIATE) ON STANDARD 11 X 17 PAPER SIZE.
6. 'RED-LINED' DRAWINGS AND PRINTS ARE TO BE MAINTAINED BY THE CONTRACTOR AND SUBMITTED TO THE PROJECT CONSTRUCTION ENGINEER AT THE COMPLETION OF THE PROJECT.
7. THE CONTRACTOR SHALL NOTIFY THE PROJECT CONSTRUCTION ENGINEER IMMEDIATELY OF 'ANY' DISCREPANCIES OR VARIATIONS IN DRAWINGS & SPECIFICATIONS THAT EFFECT PRICING OR THAT COULD REQUIRE MODIFICATION TO THE DESIGN.
8. ALL RANGE POINTS OR OTHER SURVEY MONUMENTS WHICH MAY BE DESTROYED DURING CONSTRUCTION SHALL BE TIED OUT AND RESET BY THE CITY SURVEY CREWS PER CITY SURVEYING STANDARDS.
9. ALL ELEVATIONS SHOWN ARE NAVD88 DATUM, UNLESS OTHERWISE NOTED.
10. INLETS AND MANHOLES ARE NOT SHOWN TO SCALE ON THE PLAN AND PROFILE SHEETS.
11. INVERT ELEVATIONS AND CALCULATED PIPE SLOPES ON STORM AND SANITARY PROFILES ARE TO THE CENTER OF MANHOLE OR STRUCTURE.
12. NORTHING AND EASTING CALLOUTS ON TYPE 16 AND TYPE 14 INLETS ARE TO THE CENTER OF THE STRUCTURE AT THE FLOWLINE.
13. LOCATION OF INLETS AND/OR INLET CONNECTORS MAY BE ADJUSTED IN THE FIELD AT THE DIRECTION OF THE PROJECT CONSTRUCTION ENGINEER IN CONJUNCTION WITH DESIGN INTENTION.
14. DEPTHS OR BOTTOM OF STRUCTURE ELEVATIONS WILL NOT BE PROVIDED FOR INLETS WITHIN THE PROJECT SCOPE, AS THESE ARE REQUIRED TO BE DETERMINED BASED ON FIELD CONDITIONS IN ACCORDANCE WITH APPLICABLE STANDARD DETAIL DRAWINGS.
15. ALL SEWER MANHOLES MUST BE MAINTAINED AND ACCESSIBLE DURING CONSTRUCTION.
16. THE CONTRACTOR SHALL LOCATE AND VERIFY ALL LIVE SANITARY SEWER SERVICES (TAPS) AND ENSURE THAT ALL ACTIVE TAPS AFFECTED BY THE CONSTRUCTION OPERATIONS ARE PROPERLY RECONNECTED.
17. ALL SANITARY MANHOLES ARE 4' DIAMETER WITH 'A' BASE AND CONCENTRIC CONE UNLESS NOTED OTHERWISE.
18. CHANGES IN THE ELEVATION OF AN EXISTING BRICK MANHOLE RING AND COVER MAY REQUIRE THE USE OF A PRE-CAST CONCRETE MANHOLE FLAT-TOP SECTION OR MANHOLE RECONSTRUCTION AT THE DISCRETION OF THE PROJECT INSPECTOR OR THE PROJECT CONSTRUCTION ENGINEER.
19. ALL MANHOLES BUILT WITHIN THIS PROJECT SHALL INCLUDE EITHER A 4' OR 8' CAST IRON RISER WITH 3' STEEL ADJUSTING RINGS.
20. REINFORCING STEEL:
a. ALL REBAR SHALL BE PLACED PER SHOP DRAWINGS APPROVED BY THE PROJECT CONSTRUCTION ENGINEER.
b. REINFORCING STEEL SHALL BE HOT ROLLED DEFORMED BARS, ASTM DESIGNATION A615, GRADE 60, UNLESS OTHERWISE SHOWN OR NOTED.
c. LAPS SHALL BE CLASS B (SPLICE NO MORE THAN HALF OF BARS AT ANY LOCATION), EXCEPT WHERE OTHERWISE SHOWN OR NOTED.
d. ALL CROSSING REINFORCING BARS SHALL BE TIED.
e. FOR ALL CAST-IN-PLACE REINFORCED CONCRETE STRUCTURES THE CONTRACTOR SHALL SUPPLY ADEQUATE BAR CHAIRS AND SUPPORTS FOR REINFORCING SUBJECT TO THE APPROVAL OF THE PROJECT CONSTRUCTION ENGINEER.
22. EXACT LOCATION OF ALL SAW CUTS SHALL BE DETERMINED IN THE FIELD BY THE CONSTRUCTION PROJECT ENGINEER.
23. DOWELS, PIPES, WATER STOPS AND OTHER INSTALLED MATERIALS AND ACCESSORIES SHALL BE HELD SECURELY IN POSITION WHILE CONCRETE IS BEING PLACED.
24. #67 BEDDING OR SPECIAL BEDDING IS REQUIRED FOR ALL STORM AND SANITARY SEWER PIPE, IN ACCORDANCE WITH THE STANDARD DETAILS AND TECHNICAL SPECIFICATIONS.
25. THE CONTRACTOR SHALL BACKFILL AND FINE GRADE ALL CUT OR FILL SLOPES TO MATCH EXISTING CONDITIONS TO THE SATISFACTION OF THE PROJECT CONSTRUCTION ENGINEER.
26. ANY LANE OCCUPANCY IN HAVANA (CDOT ROW) WOULD REQUIRE A CDOT LANE CLOSURE PERMIT. ANY LANE OR SIDEWALK OCCUPANCY IN A CCD STREET WILL NEED A CCD RSOP. ALLOW 5 DAYS TO PROCESS PERMIT VIA CCD.

- 27. ANY FILL MATERIAL OR SOILS TO BE MOVED TO AND PLACED ON CCD-OWNED PROPERTY OR PLACED ON REAL PROPERTY TO BE TRANSFERRED TO THE CCD MUST BE FREE OF KNOWN CONTAMINATION (OBSERVED OR PREVIOUSLY DOCUMENTED) AND BE ACCEPTABLE FOR UNRESTRICTED RESIDENTIAL USE.
28. IF UNKNOWN/UNIDENTIFIED UNDERGROUND STORAGE TANKS, DRUMS, ODOROUS SOIL, STAINED SOIL, ASBESTOS-CEMENT PIPE, TRANSITE, BUILDING DEBRIS OR WASTE MATERIALS ARE ENCOUNTERED DURING THE PROJECT, CONTRACTOR SHALL IMMEDIATELY STOP WORK IN THE AREA OF THE DISCOVERY UNTIL DENVER ENVIRONMENTAL HEALTH (DEH) MAKES A DETERMINATION OF HOW TO PROCEED.
29. THE CONTRACTOR SHALL DIRECT NON-RECYCLABLE, NON-HAZARDOUS WASTES FROM CCD-OWNED OR CONTROLLED PROPERTY OR FACILITIES TO THE DENVER ARAPAHOE DISPOSAL SITE (DADS) LANDFILL FOR DISPOSAL, FOLLOWING THE REQUIREMENT AND PROCEDURAL GUIDANCE OUTLINED IN CCD'S EXECUTIVE ORDER 115.
30. NOISE CONTROL. EXEMPTED HOURS FOR CONSTRUCTION IN THE CITY AND COUNTY OF DENVER ARE FROM 7 A.M. TO 9 P.M. MONDAY THROUGH FRIDAY AND 8 A.M. TO 5 P.M. ON SATURDAYS AND SUNDAYS PER SECTIONS 36-6.(B)(7) AND 36-7.(5)(A), B. AND C. OF DENVER'S NOISE ORDINANCE, CHAPTER 36 "NOISE CONTROL," DENVER REVISED MUNICIPAL CODE (DRMC).
31. THE CONSTRUCTION ACTIVITIES STORMWATER DISCHARGE PERMIT (CASDP) EC-2013-170 CURRENTLY HELD BY THE DPS CONTRACTOR NEEDS TO BE AMENDED TO INCLUDE THE PHASE III SCOPE OF WORK.
32. UTILITIES
a. THE TYPE, SIZE, LOCATION AND NUMBER OF ALL KNOWN UNDERGROUND UTILITIES ARE APPROXIMATE WHEN SHOWN ON THE DRAWINGS, UNLESS OTHERWISE NOTED.
b. THE CONTRACTOR SHALL BE RESPONSIBLE FOR PROTECTING UTILITIES DURING CONSTRUCTION AND SHALL HOLD THE CITY AND ITS ENGINEERS HARMLESS FOR DAMAGES ARISING FROM THE CONTRACTOR'S FAILURE TO ADEQUATELY PROTECT EXISTING UTILITIES.
c. THE CONTRACTOR IS REQUIRED TO RESET, ADJUST OR REPLACE ANY UTILITIES THAT ARE IMPACTED BY CONSTRUCTION AND ARE DESIGNED TO REMAIN WITHIN THE PROJECT LIMITS.
33. TREE PROTECTION
IF EXISTING TREES ARE TO BE REMOVED THEY MUST FIRST BE EVALUATED BY THE CITY AND COUNTY OF DENVER FORESTRY (PARKS) DEPARTMENT AND A PERMIT MUST BE OBTAINED.
34. METRO WASTEWATER RECLAMATION DISTRICT
METRO WASTEWATER RECLAMATION DISTRICT MUST BE NOTIFIED AT LEAST 48 HOURS PRIOR TO CONSTRUCTION ON METRO FACILITIES IN ORDER FOR A DISTRICT INSPECTOR TO BE PRESENT DURING CONSTRUCTION.

ABBREVIATIONS

Table with 4 columns: Abbreviation, Description, Abbreviation, Description. Includes entries like APPROX - APPROXIMATELY, CL - CENTER LINE, CCD - CITY AND COUNTY OF DENVER, CFS - CUBIC FEET PER SECOND, C & G - CURB AND GUTTER, C G & SW - CURB, GUTTER, & SIDEWALK, CH - CURB HEAD, CIP - CORRUGATED IRON PIPE (WATER), CPM - CAPITAL PROJECTS MANAGEMENT, DIP - DUCTILE IRON PIPE (WATER), DT - DECIDUOUS TREE, DWD - DENVER WATER DEPARTMENT, E - EAST, EF - EACH FACE, E.G.L. - ENERGY GRADE LINE, EOA - EDGE OF ASPHALT, ES - EACH SIDE, EX - EXISTING, EW - EACH WAY, FG - FINAL GRADE, FL - FLOW LINE, FO - FIBER OPTIC LINE, G - GAS, H.G.L. - HYDRAULIC GRADE LINE, I - INLET, INV. - INVERT, LF - LINEAR FEET, MH - MANHOLE, MJ - MECHANICAL JOINT, N - NORTH, NTS - NOT TO SCALE, OHE - OVERHEAD ELECTRIC LINE, PL - PROPERTY LINE, PVC - POLY VINYL CHLORIDE, Q - DESIGN FLOW, Qfull - FULL FLOW CAPACITY, RCBC - REINFORCED CONCRETE BOX CULVERT, RCP - REINFORCED CONCRETE PIPE, R.L. - RANGE LINE, S - SOUTH, STM - STORM SEWER, SS - SANITARY SEWER, SW - SIDEWALK, TELE- TELEPHONE LINE, TH - TEST HOLE, TOC - TOP OF CONCRETE, T.O.P. - TOP OF PIPE, T.O.W. - TOP OF WALL, TYP. - TYPICAL, UE - UNDERGROUND ELECTRIC LINE, U.N.O. - UNLESS NOTED OTHERWISE, VCP - VITRIFIED CLAY PIPE, W - WEST, WAT - WATER, WMD - WASTEWATER MANAGEMENT DIVISION

SURVEY FEATURES LEGEND

Table with 3 columns: Symbol, Description, Symbol, Description. Includes BENCHMARK, CHISELED 'X', TRAVERSE POINT, RANGE POINT, LAND CORNER, PIN & CAP, REBAR, EASEMENT LINE, SECTION LINE, PROPERTY LINE (NOT R.O.W.), RANGELINE, R.O.W. LINE

EXISTING FEATURES LEGEND

Table with 2 columns: Symbol, Description. Includes EXISTING STREET LIGHT, EXISTING UTILITY/POWER POLE, EXISTING GUY WIRE, EXISTING TRAFFIC POLE, EXISTING TRAFFIC CONTROL BOX, EXISTING TRAFFIC CONTROL SWITCH BOX, EXISTING ELECTRIC METER, EXISTING ELECTRIC BOX, EXISTING FIRE HYDRANT, EXISTING WATER VALVE, EXISTING WATER MH, EXISTING WATER METER, EXISTING GAS MANHOLE, EXISTING STORM INLETS, EXISTING STREET SIGN, EXISTING POST, EXISTING TRASH RECEPTACLE, EXISTING TRASH DUMPSTER, EXISTING BUS BENCH, EXISTING MAIL BOX, EXISTING NEWSPAPER BOX, EXISTING TELEPHONE MH, EXISTING TELEPHONE BOX, EXISTING TELEPHONE BOOTH, EXISTING TREE, EXISTING SHRUB

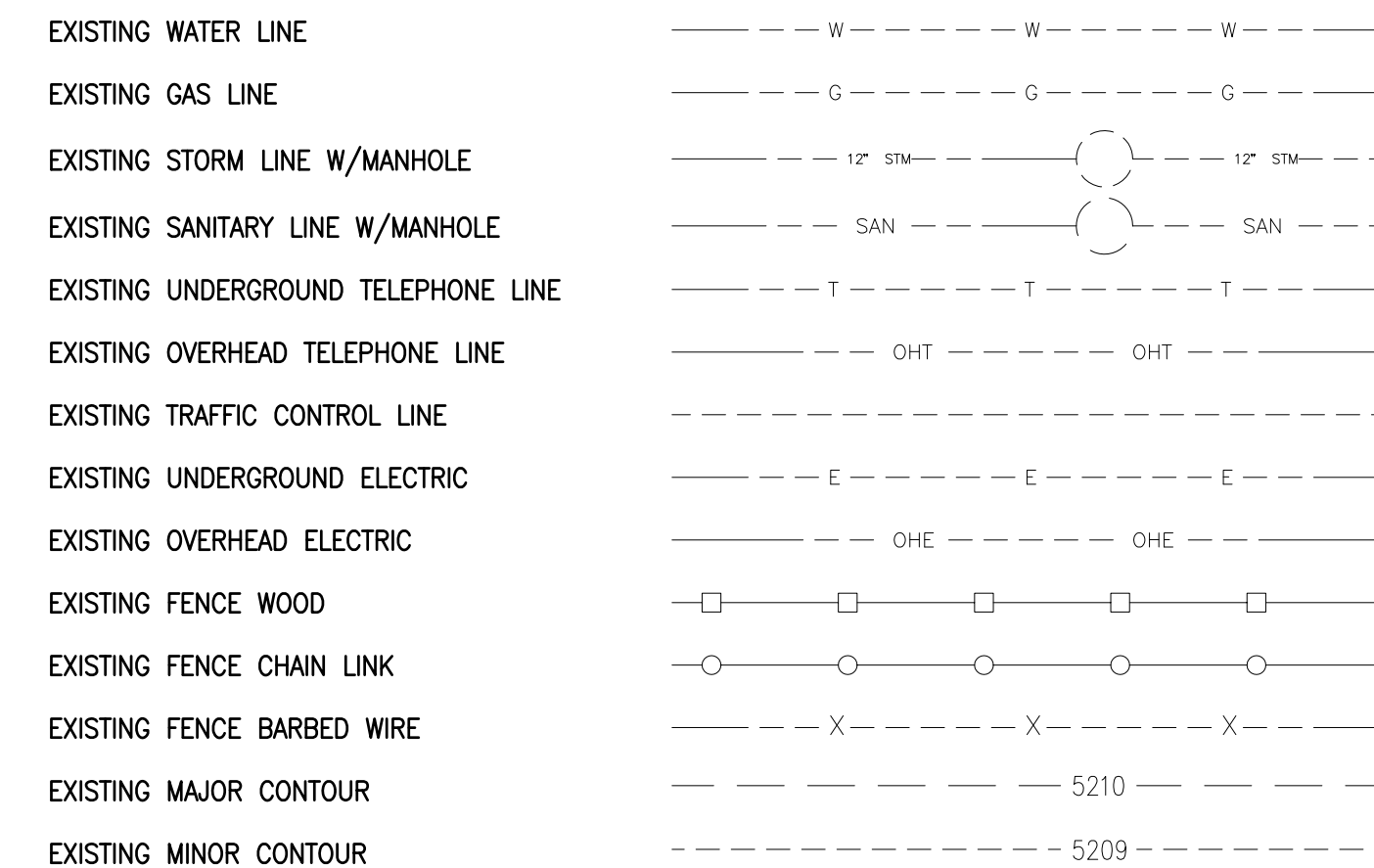

PROPOSED FEATURES LEGEND

Table with 2 columns: Symbol, Description. Includes PROPOSED STORM INLET, PROPOSED STORM SEWER W/MANHOLE, PROPOSED SANITARY SEWER W/MANHOLE, PROPOSED MAJOR CONTOUR, PROPOSED MINOR CONTOUR, PROPOSED CURB & GUTTER, PROPOSED FH, PROPOSED WATER, PROPOSED WATER VALVE, PROPOSED WATER REDUCER, PROPOSED WATER BENDS AND/OR TEES, PROPOSED GRASS AND/OR MULCH- REPLACE EXISTING LANDSCAPING MATERIAL, PROPOSED CONCRETE UNLESS SPECIFIED OTHERWISE, PROPOSED CURB RAMP, PROPOSED DRAINAGE FLOW ARROW



Enginity Engineering Solutions
10106 W. San Juan Way
Suite 215
Littleton, CO 80127
Phone: 303.872.9112
Fax: 303.872.9104

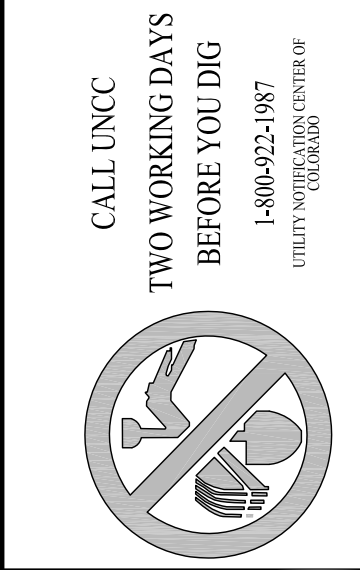

CITY AND COUNTY OF DENVER
DEPARTMENT OF PUBLIC WORKS
ENGINEERING DIVISION
CAPITAL PROJECTS MANAGEMENT
2000 W. 3RD AVE. DENVER, CO 80223
TEL.: (303) 446-3617 FAX: (303) 446-3647

HAMPDEN HEIGHTS STORM SEWER IMPROVEMENTS - PHASE III
E. GIRARD AVE. OUTFALL
PCO CONTROL NO:
PILAR REVIEW NO:
GENERAL NOTES

Table with 2 columns: Field, Value. Includes DRAWN BY: JWS, DESIGNED BY: JWS, APPROVED BY: DJJ, DRAWING NAME: General Notes - Phase III.dwg, DATE: 03/18/15, SHEET NO.: 2 of 32

C:\ENGINUTY\PROJECTS\DENVER\13-006 HAMPDEN HEIGHTS PHASE II OUTFALL\CADD\PLANS\DETAILS\GENERAL NOTES - PHASE III.DWG PLOT DATE: March 30, 2015

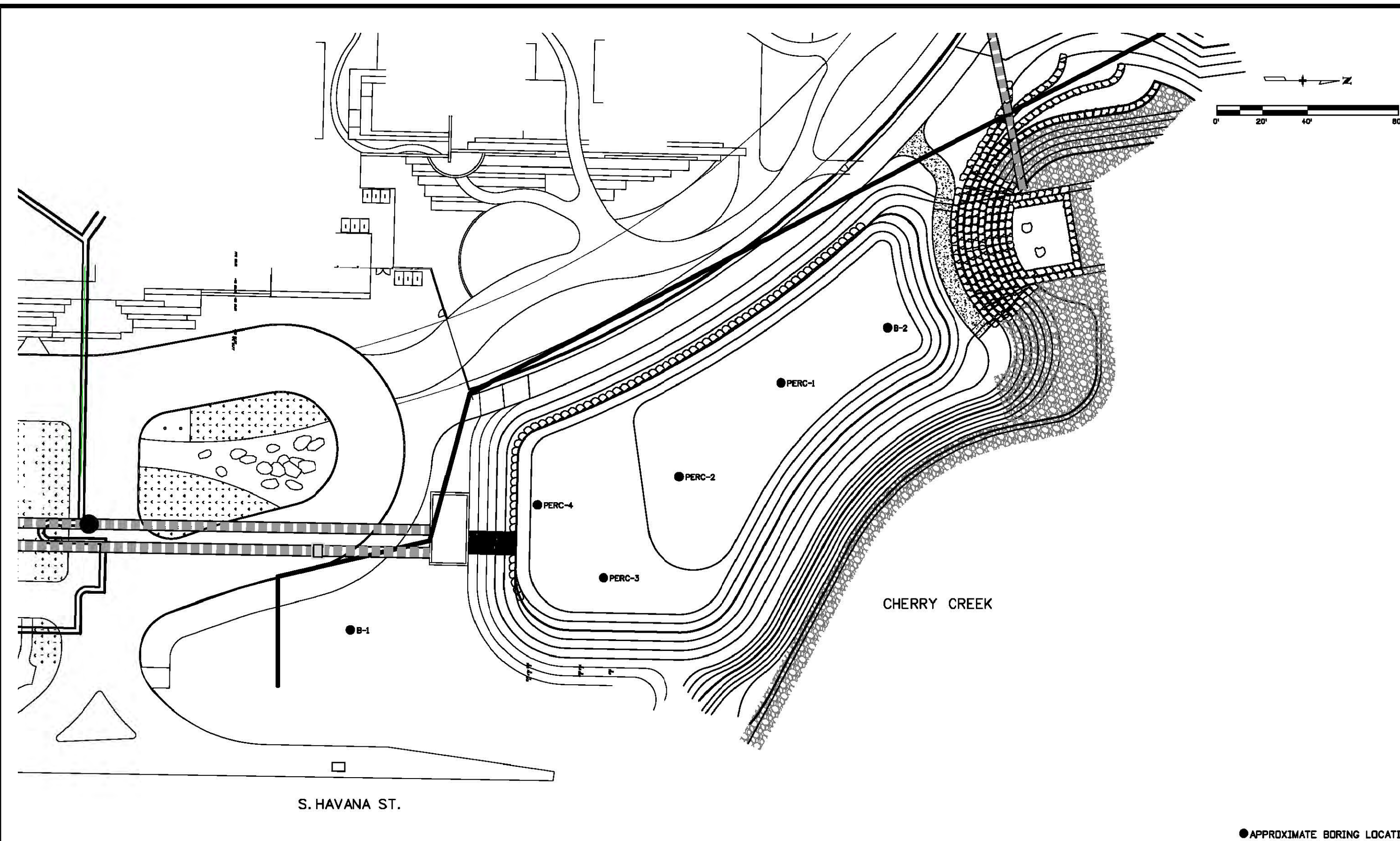

● APPROXIMATE BORING LOCATION

1 GEOTECHNICAL BORING LOCATIONS

YEH AND ASSOCIATES, INC. GEOTECHNICAL ENGINEERING CONSULTANTS		Project: Hampden Heights Phase II Project Number: 213-091 Date:		Boring: B - 1 Sheet 1 of 1					
Boring Began: 8/29/2013		Completed: 8/29/2013		Total Depth: 21.0 ft					
Drilling Method: Solid-Stem Auger		Drill Bit: Casing		Ground Elevation: Location:					
Drill: D-50 Dietrich		Weather: Clear		Coordinates: N: E:					
Driller: Dakota		Ground Water Notes:		Observed at approximately 6 feet at time of drilling					
Logged By: S. Maloney		Depth Date Time		14.0 ft 8/29/13					
Final By: S. Holder		Inclination: Vertical							
Elevation (feet)	Depth (feet)	Run / Sample Type	Recovery (%)	RQD	Blows per 6 in	N	Lithology	Material Description	Field Notes and Lab Tests
5	5				6/6	12		0.0 - 5.0 ft. gravelly SAND with some silt, brown, moist, medium dense.	MC= 21.5 % DD= 97.9 pcf S= 0.006 %
10	10				15/15	30		5.0 - 8.0 ft. CLAY with some sand, black, moist, silt.	MC= 2.9 % DD= 119.2 pcf #200= 4 % LL= NV PL= NP PI= NP AASHTO: A-1-b (0) USCS: SW
15	15				7/12	19		8.0 - 21.0 ft. silty SAND, light brown, moist to wet, medium dense.	MC= 8.4 % DD= 124.2 pcf
20	20				17/23	40			MC= 1.2 %
Bottom of Hole at 21.0 ft.									

2 BORING RESULTS

YEH AND ASSOCIATES, INC. GEOTECHNICAL ENGINEERING CONSULTANTS		Project: Hampden Heights Phase II Project Number: 213-091 Date:		Boring: B - 2 Sheet 1 of 1					
Boring Began: 1/28/2014		Completed: 1/28/2014		Total Depth: 21.5 ft					
Drilling Method: Solid-Stem Auger		Drill Bit: Casing		Ground Elevation: Location:					
Drill: Track Mounted CME 50, Manual Hammer		Weather: Cool, Calm, Clear		Coordinates: N: E:					
Driller: Dakota Drilling		Ground Water Notes:		Observed at approximately 6 feet at time of drilling					
Logged By: R. Beach		Depth Date Time		6.0 ft 1/14/14					
Final By: R. Beach		Inclination: Vertical							
Elevation (feet)	Depth (feet)	Run / Sample Type	Recovery (%)	RQD	Blows per 6 in	N	Lithology	Material Description	Field Notes and Lab Tests
5	5				8/7/8	15		0.0 - 21.5 ft. silty SAND with occasional gravels, light brown to dark brown, moist to wet, medium dense to dense.	MC= 15.4 % #200= 7 % LL= NV PL= NP PI= NP S= 0.005 % AASHTO: A-1-b (0) USCS: SW-SP
10	10				11/12/12	23			
15	15				15/23/25	38			MC= 10.8 % #200= 3 % LL= NV PL= NP PI= NP AASHTO: A-1-b (0) USCS: SP
20	20				14/22/24	36			
Bottom of Hole at 21.5 ft.									

YEH AND ASSOCIATES, INC. GEOTECHNICAL ENGINEERING CONSULTANTS		Project: Hampden Heights Phase II Project Number: 213-091 Date:		Boring: PERC-1 Sheet 1 of 1					
Boring Began: 1/28/2014		Completed: 1/28/2014		Total Depth: 5.0 ft					
Drilling Method: Solid-Stem Auger		Drill Bit: Casing		Ground Elevation: Location:					
Drill: Track Mounted CME 50, Manual Hammer		Weather: Cool, Calm, Clear		Coordinates: N: E:					
Driller: Dakota Drilling		Ground Water Notes:		Not observed at time of drilling					
Logged By: R. Beach		Depth Date Time							
Final By: R. Beach		Inclination: Vertical							
Elevation (feet)	Depth (feet)	Run / Sample Type	Recovery (%)	RQD	Blows per 6 in	N	Lithology	Material Description	Field Notes and Lab Tests
5	5							0.0 - 5.0 ft. silty SAND with occasional gravel, brown, moist.	
Bottom of Hole at 5.0 ft.									
Perc. Rate at 4 inches/min									

YEH AND ASSOCIATES, INC. GEOTECHNICAL ENGINEERING CONSULTANTS		Project: Hampden Heights Phase II Project Number: 213-091 Date:		Boring: PERC-2 Sheet 1 of 1					
Boring Began: 1/28/2014		Completed: 1/28/2014		Total Depth: 5.0 ft					
Drilling Method: Solid-Stem Auger		Drill Bit: Casing		Ground Elevation: Location:					
Drill: Track Mounted CME 50, Manual Hammer		Weather: Cool, Calm, Clear		Coordinates: N: E:					
Driller: Dakota Drilling		Ground Water Notes:		Not observed at time of drilling					
Logged By: R. Beach		Depth Date Time							
Final By: R. Beach		Inclination: Vertical							
Elevation (feet)	Depth (feet)	Run / Sample Type	Recovery (%)	RQD	Blows per 6 in	N	Lithology	Material Description	Field Notes and Lab Tests
5	5							0.0 - 5.0 ft. silty SAND with occasional gravel, brown, moist.	
Bottom of Hole at 5.0 ft.									
Perc. Rate at 3 inches/min									

YEH AND ASSOCIATES, INC. GEOTECHNICAL ENGINEERING CONSULTANTS		Project: Hampden Heights Phase II Project Number: 213-091 Date:		Boring: PERC-3 Sheet 1 of 1					
Boring Began: 1/28/2014		Completed: 1/28/2014		Total Depth: 5.0 ft					
Drilling Method: Solid-Stem Auger		Drill Bit: Casing		Ground Elevation: Location:					
Drill: Track Mounted CME 50, Manual Hammer		Weather: Cool, Calm, Clear		Coordinates: N: E:					
Driller: Dakota Drilling		Ground Water Notes:		Not observed at time of drilling					
Logged By: R. Beach		Depth Date Time							
Final By: R. Beach		Inclination: Vertical							
Elevation (feet)	Depth (feet)	Run / Sample Type	Recovery (%)	RQD	Blows per 6 in	N	Lithology	Material Description	Field Notes and Lab Tests
5	5							0.0 - 5.0 ft. silty SAND with occasional gravel, brown, moist.	
Bottom of Hole at 5.0 ft.									

YEH AND ASSOCIATES, INC. GEOTECHNICAL ENGINEERING CONSULTANTS		Project: Hampden Heights Phase II Project Number: 213-091 Date:		Boring: PERC-4 Sheet 1 of 1					
Boring Began: 1/28/2014		Completed: 1/28/2014		Total Depth: 5.0 ft					
Drilling Method: Solid-Stem Auger		Drill Bit: Casing		Ground Elevation: Location:					
Drill: Track Mounted CME 50, Manual Hammer		Weather: Cool, Calm, Clear		Coordinates: N: E:					
Driller: Dakota Drilling		Ground Water Notes:		Not observed at time of drilling					
Logged By: R. Beach		Depth Date Time							
Final By: R. Beach		Inclination: Vertical							
Elevation (feet)	Depth (feet)	Run / Sample Type	Recovery (%)	RQD	Blows per 6 in	N	Lithology	Material Description	Field Notes and Lab Tests
5	5							0.0 - 5.0 ft. silty SAND with occasional gravel, brown, moist.	
Bottom of Hole at 5.0 ft.									

3 PERCOLATION TEST RESULTS

1"=40'

C:\ENGINEERING\PROJECTS\DENVER\13-006_HAMPDEN_HEIGHTS_PHASE_II_OUTFALL\CADD\PLANS\DETAILS\GEOTECHNICALBORINGS\BMBT DATE: March 30, 2015

DATE: _____ BY: _____

DESCRIPTION OF REVISIONS:

NO.	DESCRIPTION

CALL UNCC
TWO WORKING DAYS
BEFORE YOU DIG

1-800-922-1987
UTILITY VERIFICATION CENTER

CITY AND COUNTY OF DENVER
DEPARTMENT OF PUBLIC WORKS
ENGINEERING DIVISION
CAPITAL PROJECTS MANAGEMENT
2000 W. 3RD AVE., DENVER, CO 80223
TEL.: (303) 446-3617 FAX: (303) 446-3647

HAMPDEN HEIGHTS STORM SEWER
IMPROVEMENTS - PHASE III
E. GIRARD AVE. OUTFALL
PCO CONTROL NO:
PILAR REVIEW NO:
GEOTECHNICAL DATA

DRAWN BY: JWS
DESIGNED BY: JWS
APPROVED BY: DJJ
DRAWING NAME: GeotechnicalBorings.dwg
DATE: 12/5/14
SHEET NO: 3 of 28

10106 W. San Juan Way
Suite 215
Littleton, CO 80127
Phone: 303.872.9112
Fax: 303.872.9104

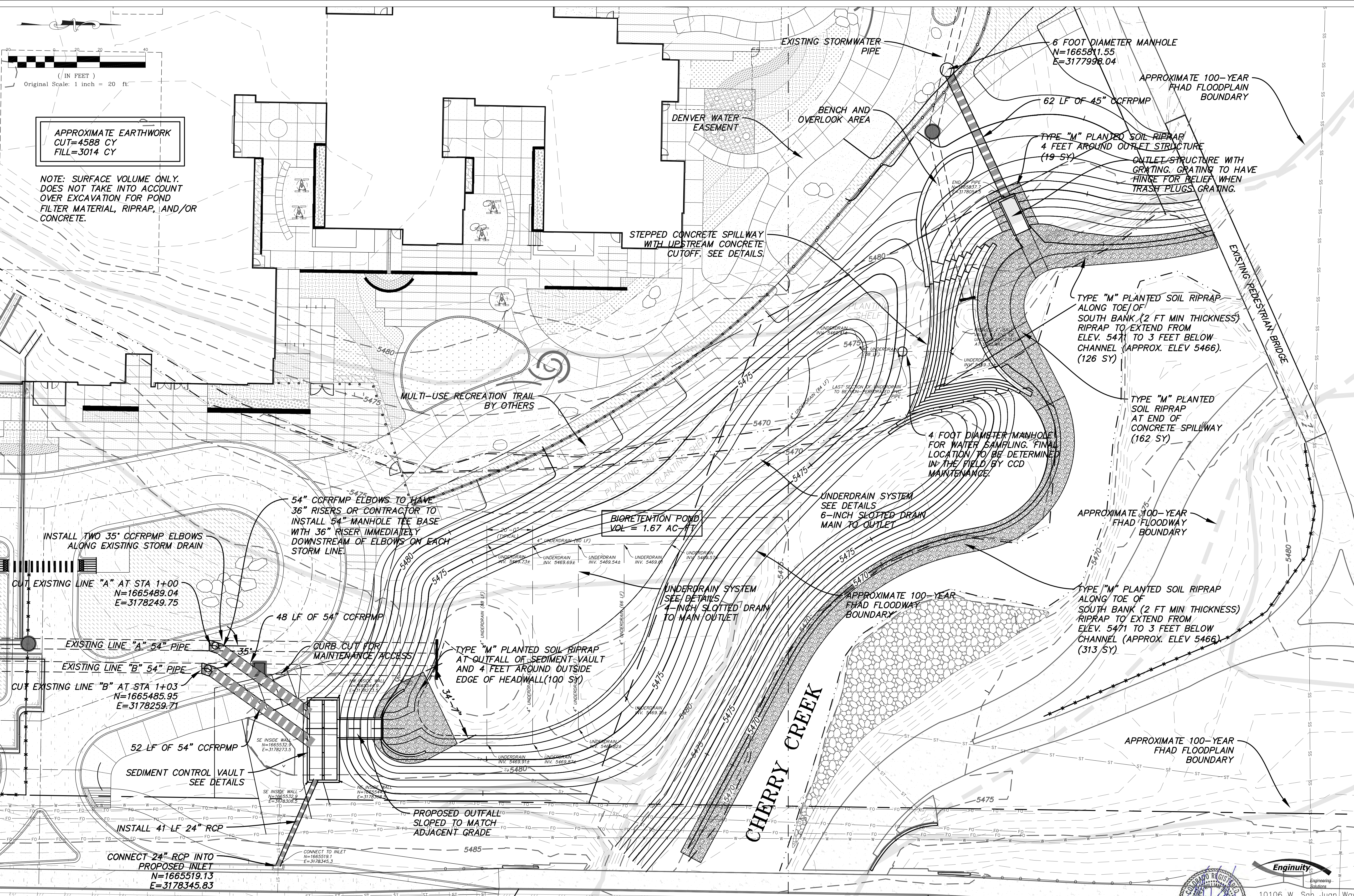

APPROXIMATE EARTHWORK
 CUT=4588 CY
 FILL=3014 CY

NOTE: SURFACE VOLUME ONLY.
 DOES NOT TAKE INTO ACCOUNT
 OVER EXCAVATION FOR POND
 FILTER MATERIAL, RIPRAP, AND/OR
 CONCRETE.

C:\ENGINEERING\PROJECTS\DENVER\13-006_HAMPDEN HEIGHTS PHASE III OUTFALL CADD\PLANS\MASTER DESIGN\MASTERWORK\REVISED\MARCH 30, 2015

DATE	
DESCRIPTION OF REVISIONS	
NO.	
CALL UNCC TWO WORKING DAYS BEFORE YOU DIG	
CITY AND COUNTY OF DENVER DEPARTMENT OF PUBLIC WORKS ENGINEERING DIVISION CAPITAL PROJECTS MANAGEMENT 2000 W. 3RD AVE. DENVER, CO 80223 TEL.: (303) 446-3617 FAX: (303) 446-3647	
HAMPDEN HEIGHTS STORM SEWER IMPROVEMENTS - PHASE III E. GIRARD AVE. OUTFALL PCO CONTROL NO: PWC2009-5013 PILAR REVIEW NO: 2011-0426-01 SITE PLAN	
DRAWN BY:	JWS
DESIGNED BY:	JWS
APPROVED BY:	DJJ
DRAWING NAME:	DesignMaster Working.dwg
DATE:	03/18/15
SHEET NO.:	5 of 32

 Enginuity
 Engineering Solutions
 10106 W. San Juan Way
 Suite 215
 Littleton, CO 80127
 Phone: 303.872.9112
 Fax: 303.872.9104

S. HAVANA STREET

C:\ENGINEERING\PROJECTS\DENVER\13-006 HAMPDEN HEIGHTS PHASE II OUTFALL\CADD\PLANS\MASTER DESIGN\MASTERWORK\PHASE II\March 30, 2015

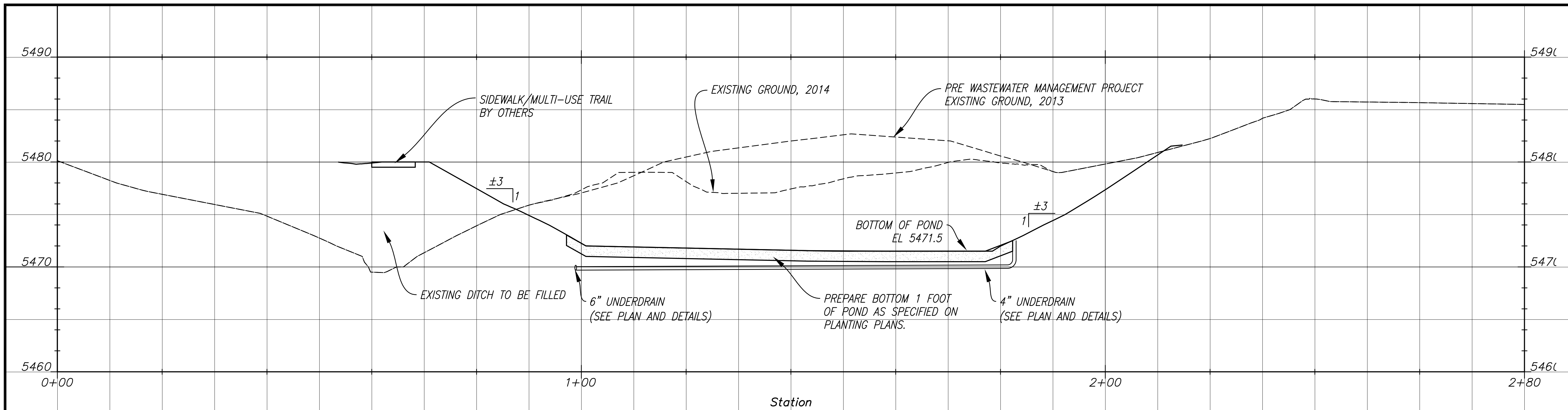

Pond Section E-W PROFILE

NOTES REGARDING EMBANKMENT PLACEMENT:

1. ALL EMBANKMENT AND FILL MATERIAL WILL BE COMPACTED TO 98% OF THE MAXIMUM DENSITY (ASTM D 698) AT 1% BELOW TO 3% ABOVE OPTIMUM MOISTURE.
2. THE GROUND SURFACE UNDERLYING EMBANKMENTS SHALL BE STRIPPED AND CLEARED OF ALL ORGANIC MATERIAL, SCARIFIED TO A DEPTH OF 8" AND RECOMPACTED PRIOR TO PLACEMENT.
3. NO EMBANKMENT MATERIAL WILL BE PLACED WITHOUT APPROVAL OF THE FOUNDATION FROM THE ENGINEER.
4. EMBANKMENT BACKFILL SHALL BE PLACED IN HORIZONTAL LIFTS NOT TO EXCEED 8" IN HEIGHT.

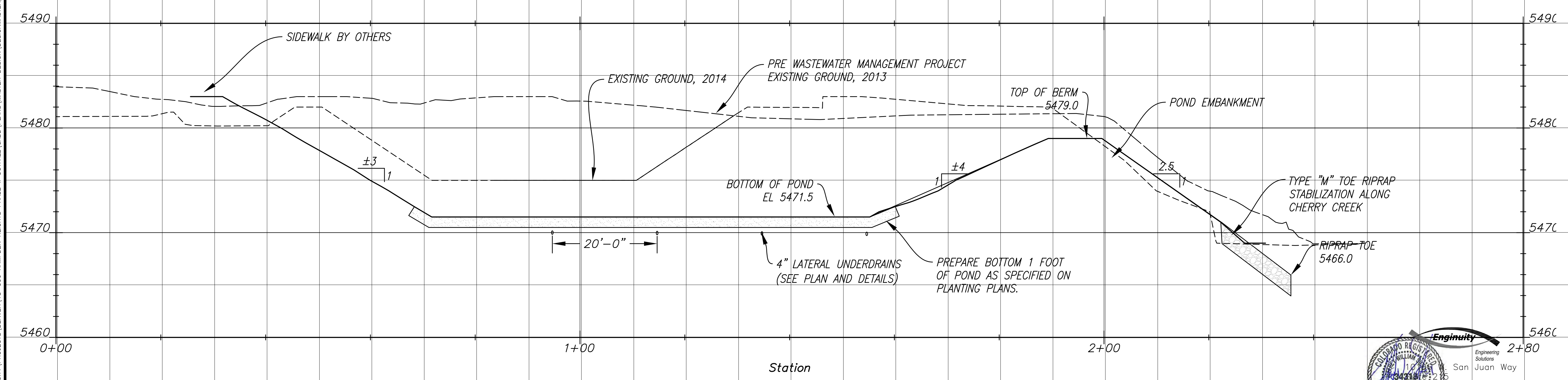

Pond Section N-S PROFILE

NO.	DESCRIPTION OF REVISIONS	DATE	BY

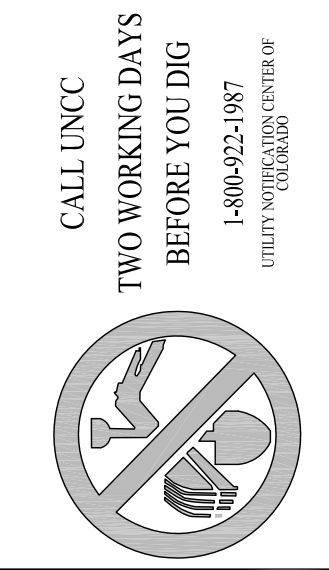

CITY AND COUNTY OF DENVER
 DEPARTMENT OF PUBLIC WORKS
 ENGINEERING DIVISION
 CAPITAL PROJECTS MANAGEMENT
 2000 W. 3RD AVE. DENVER, CO 80223
 TEL.: (303) 446-3617 FAX: (303) 446-3647

HAMPDEN HEIGHTS STORM SEWER
 IMPROVEMENTS - PHASE III
 E. GIRARD AVE. OUTFALL
 PCO CONTROL NO: PWC2009-5013
 PILAR REVIEW NO: 2011-0426-01
 TYPICAL POND SECTIONS

DRAWN BY:	JWS
DESIGNED BY:	JWS
APPROVED BY:	DJJ
DRAWING NAME:	DesignMaster Working.dwg
DATE:	03/18/15
SHEET NO.:	6 of 32

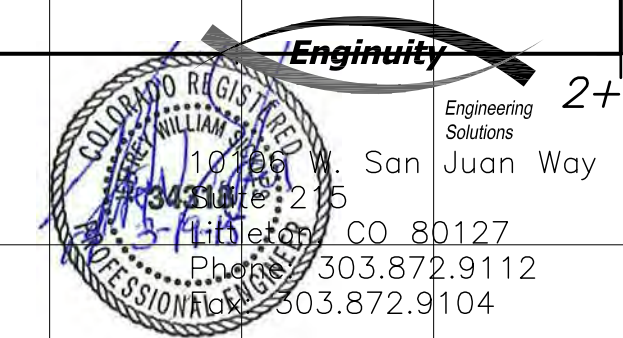

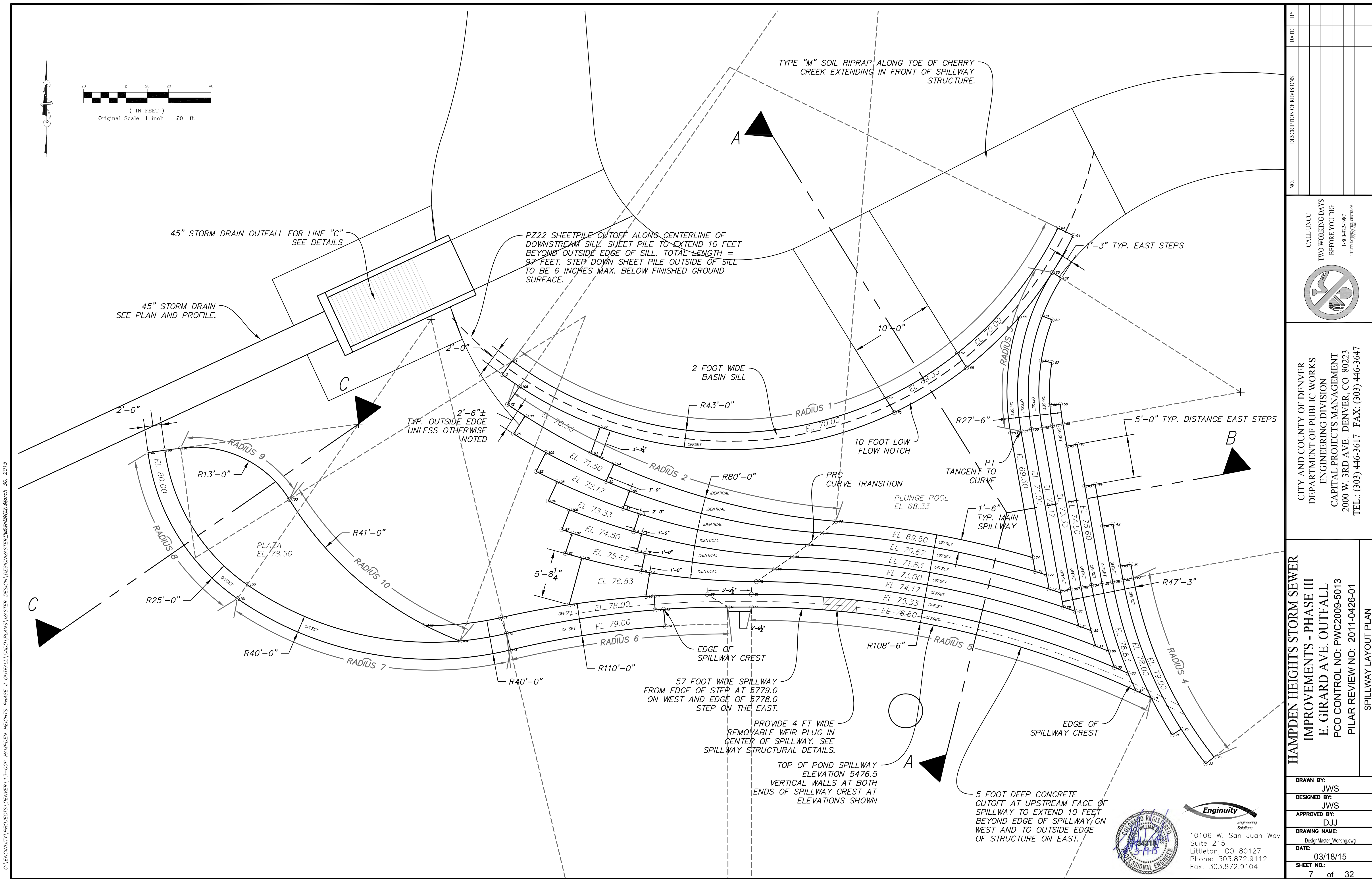
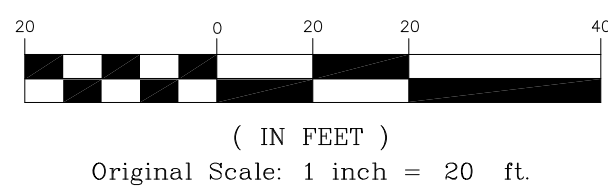

C:\ENGINEERING\PROJECTS\DENVER\13-006_HAMPDEN HEIGHTS PHASE II OUTFALL\CADD\PLANS\MASTER DESIGN\MASTERWORK\HAMPDEN.dwg March 30, 2015

NO.	DESCRIPTION OF REVISIONS	DATE	BY

CALL UNCC
TWO WORKING DAYS
BEFORE YOU DIG
1-800-922-1987
UTILITY WARNING CENTER

CITY AND COUNTY OF DENVER
DEPARTMENT OF PUBLIC WORKS
ENGINEERING DIVISION
CAPITAL PROJECTS MANAGEMENT
2000 W. 3RD AVE. DENVER, CO 80223
TEL.: (303) 446-3617 FAX: (303) 446-3647

**HAMPDEN HEIGHTS STORM SEWER
IMPROVEMENTS - PHASE III
E. GIRARD AVE. OUTFALL**
PCO CONTROL NO: PWC2009-5013
PILAR REVIEW NO: 2011-0426-01
SPILLWAY LAYOUT PLAN

DRAWN BY:	JWS
DESIGNED BY:	JWS
APPROVED BY:	DJJ
DRAWING NAME:	DesignMaster Working.dwg
DATE:	03/18/15
SHEET NO.:	7 of 32



Enginuity
Engineering Solutions
10106 W. San Juan Way
Suite 215
Littleton, CO 80127
Phone: 303.872.9112
Fax: 303.872.9104

C:\ENGINEERING\PROJECTS\DENVER\13-006 HAMPDEN HEIGHTS PHASE II OUTFALL\CADD\PLANS\MASTER DESIGN\MASTERWORK\13-006 March 30, 2015

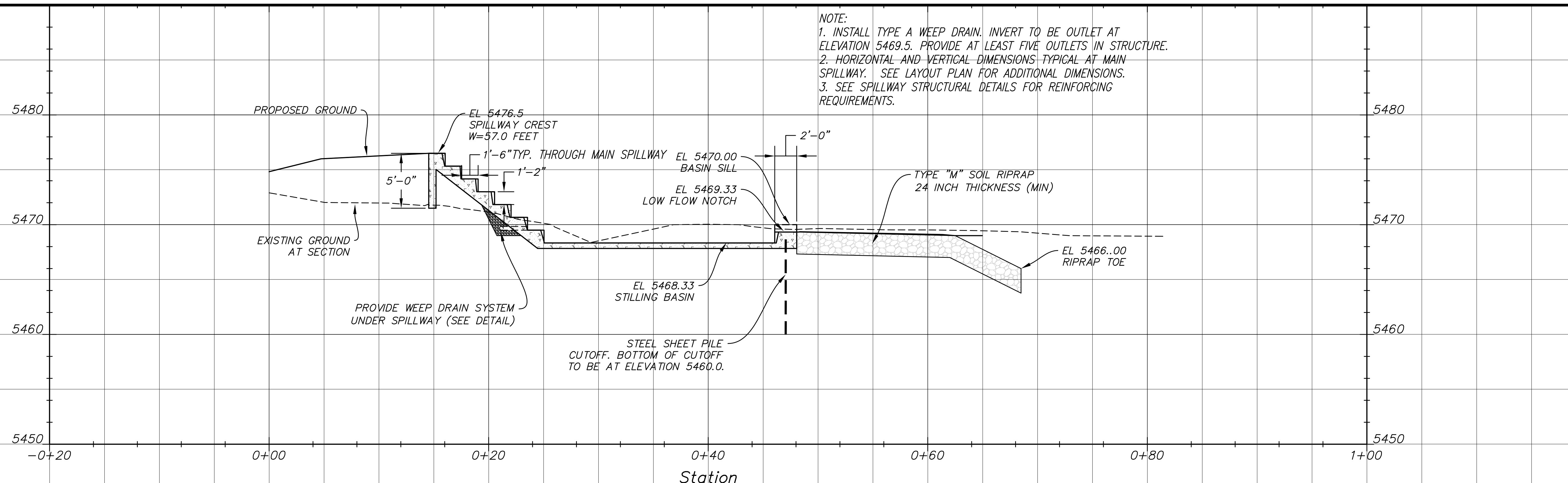

NOTE:
 1. INSTALL TYPE A WEEP DRAIN. INVERT TO BE OUTLET AT ELEVATION 5469.5. PROVIDE AT LEAST FIVE OUTLETS IN STRUCTURE.
 2. HORIZONTAL AND VERTICAL DIMENSIONS TYPICAL AT MAIN SPILLWAY. SEE LAYOUT PLAN FOR ADDITIONAL DIMENSIONS.
 3. SEE SPILLWAY STRUCTURAL DETAILS FOR REINFORCING REQUIREMENTS.

Spillway Section A PROFILE

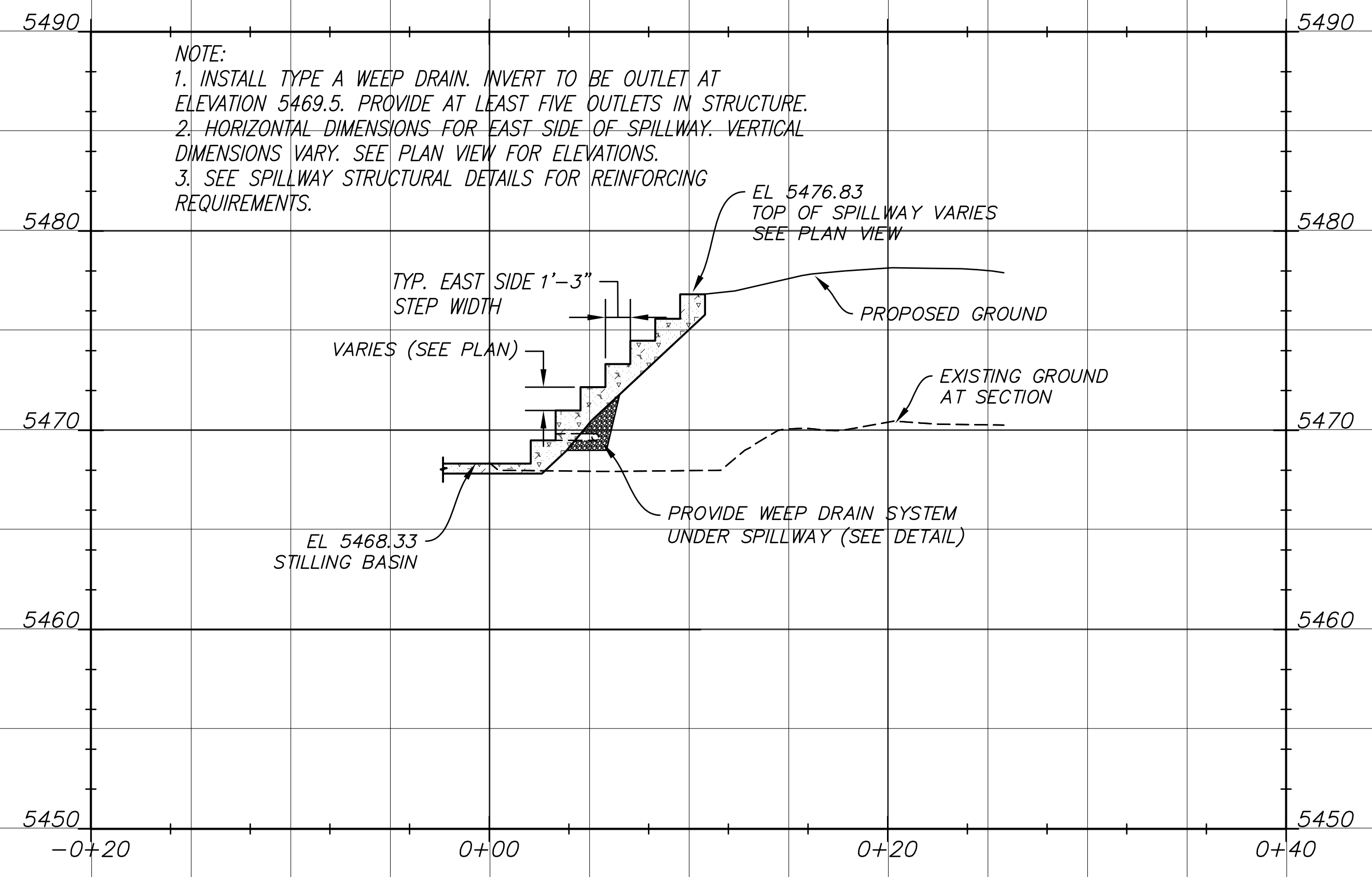

NOTE:
 1. INSTALL TYPE A WEEP DRAIN. INVERT TO BE OUTLET AT ELEVATION 5469.5. PROVIDE AT LEAST FIVE OUTLETS IN STRUCTURE.
 2. HORIZONTAL DIMENSIONS FOR EAST SIDE OF SPILLWAY. VERTICAL DIMENSIONS VARY. SEE PLAN VIEW FOR ELEVATIONS.
 3. SEE SPILLWAY STRUCTURAL DETAILS FOR REINFORCING REQUIREMENTS.

Spillway Section B PROFILE

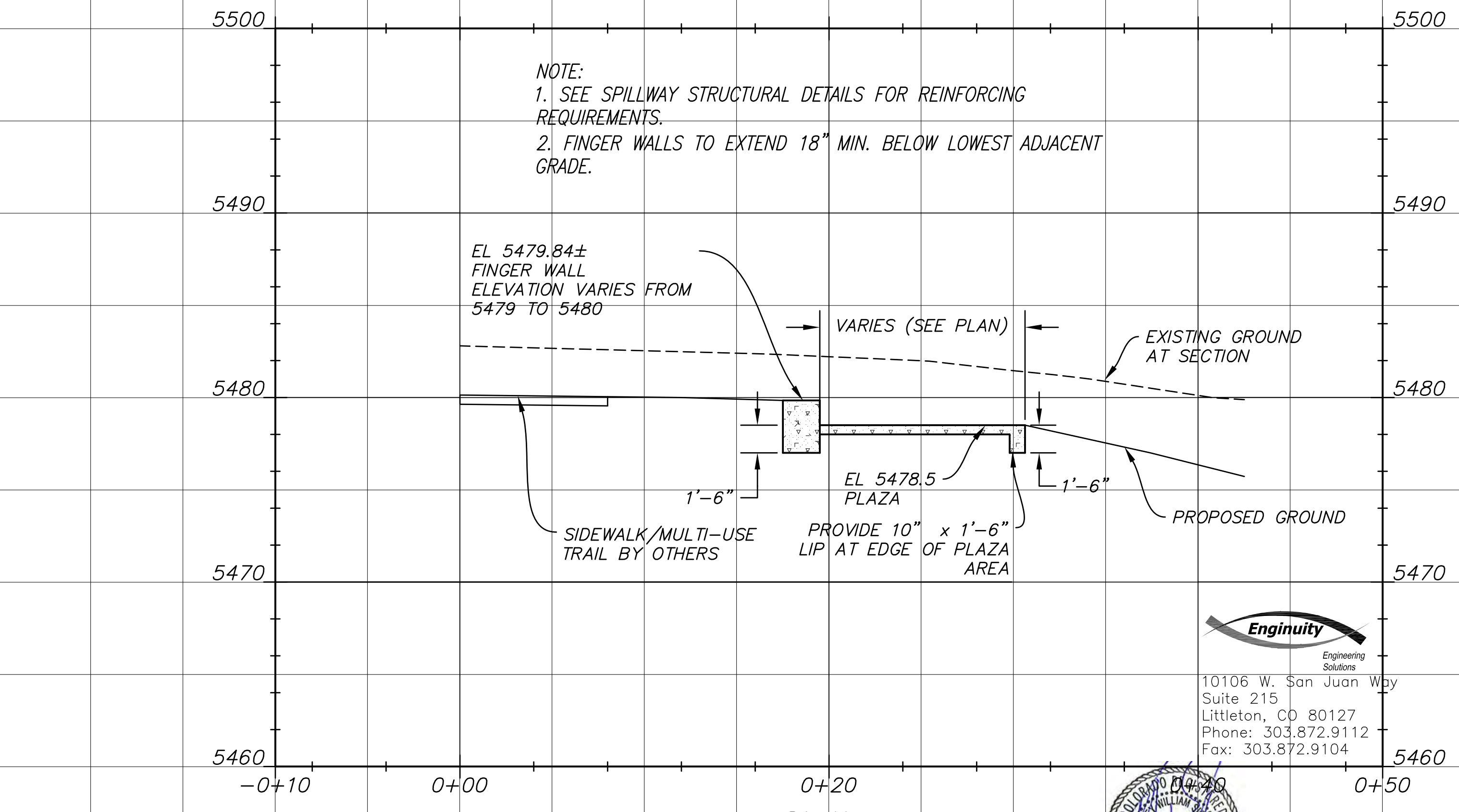

NOTE:
 1. SEE SPILLWAY STRUCTURAL DETAILS FOR REINFORCING REQUIREMENTS.
 2. FINGER WALLS TO EXTEND 18" MIN. BELOW LOWEST ADJACENT GRADE.

Spillway Section C PROFILE

Enginuity
 Engineering Solutions
 10106 W. San Juan Way
 Suite 215
 Littleton, CO 80127
 Phone: 303.872.9112
 Fax: 303.872.9104



NO.	DESCRIPTION OF REVISIONS	DATE	BY
<p>CALL UNCC TWO WORKING DAYS BEFORE YOU DIG 1-800-922-1987 UTILITY LOCATION CENTER</p> 			
<p>CITY AND COUNTY OF DENVER DEPARTMENT OF PUBLIC WORKS ENGINEERING DIVISION CAPITAL PROJECTS MANAGEMENT 2000 W. 3RD AVE. DENVER, CO 80223 TEL.: (303) 446-3617 FAX: (303) 446-3647</p>			
<p>HAMPDEN HEIGHTS STORM SEWER IMPROVEMENTS - PHASE III E. GIRARD AVE. OUTFALL PCO CONTROL NO: PWC2009-5013 PILAR REVIEW NO: 2011-0426-01</p>			
<p>SPILLWAY SECTIONS</p>			
DRAWN BY: JWS			
DESIGNED BY: JWS			
APPROVED BY: DJJ			
DRAWING NAME: DesignMaster Working.dwg			
DATE: 03/18/15			
SHEET NO.: 9 of 32			

C:\ENGINEERING\PROJECTS\DENVER\15-006_HAMPDEN HEIGHTS PHASE II OUTFALL\CADD\PLANS\DETAILS\HAMPDEN HEIGHTS - BRW\CDPWR_MRTWALL_SDW2015

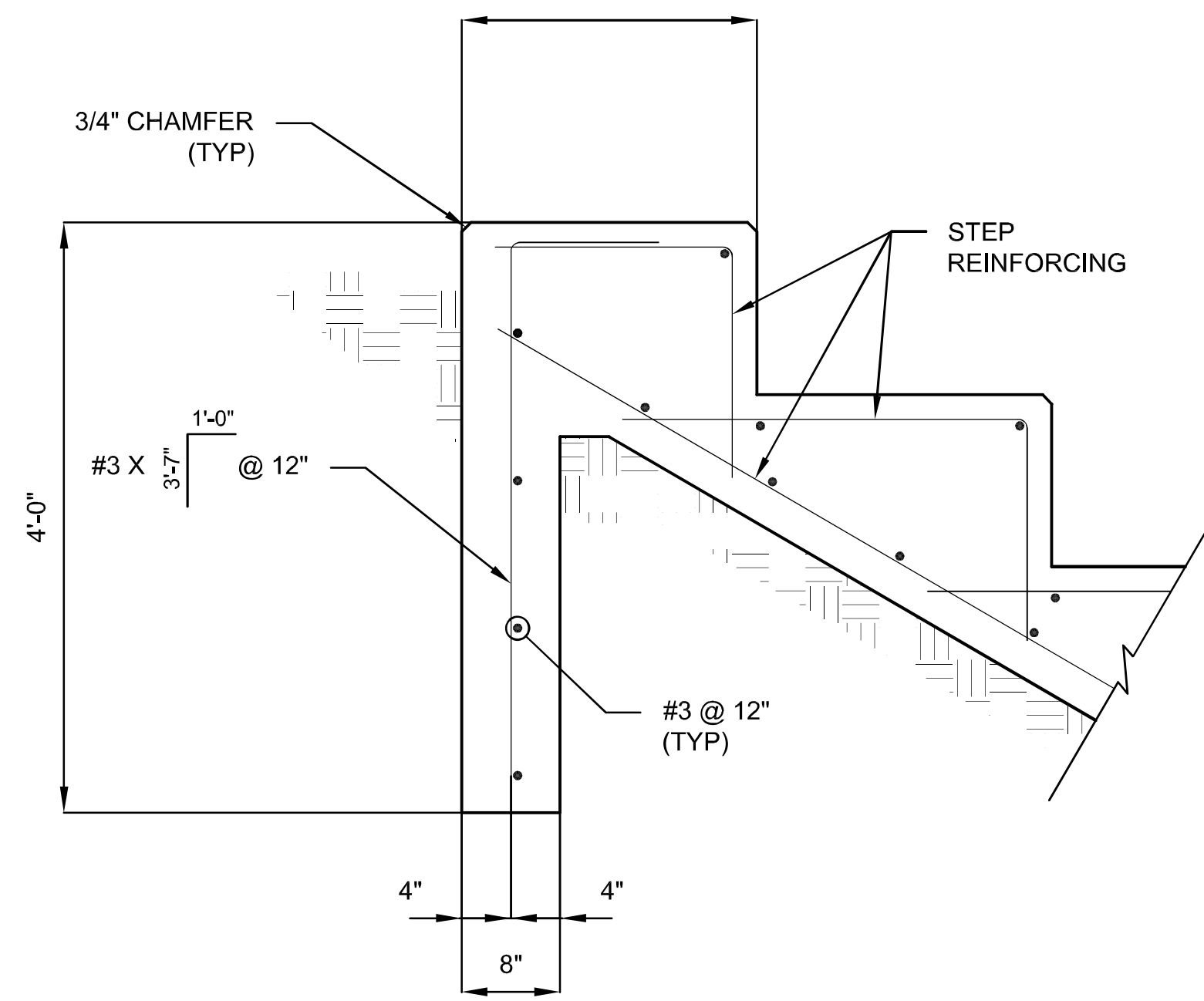

SECTION AT CUTOFF WALL

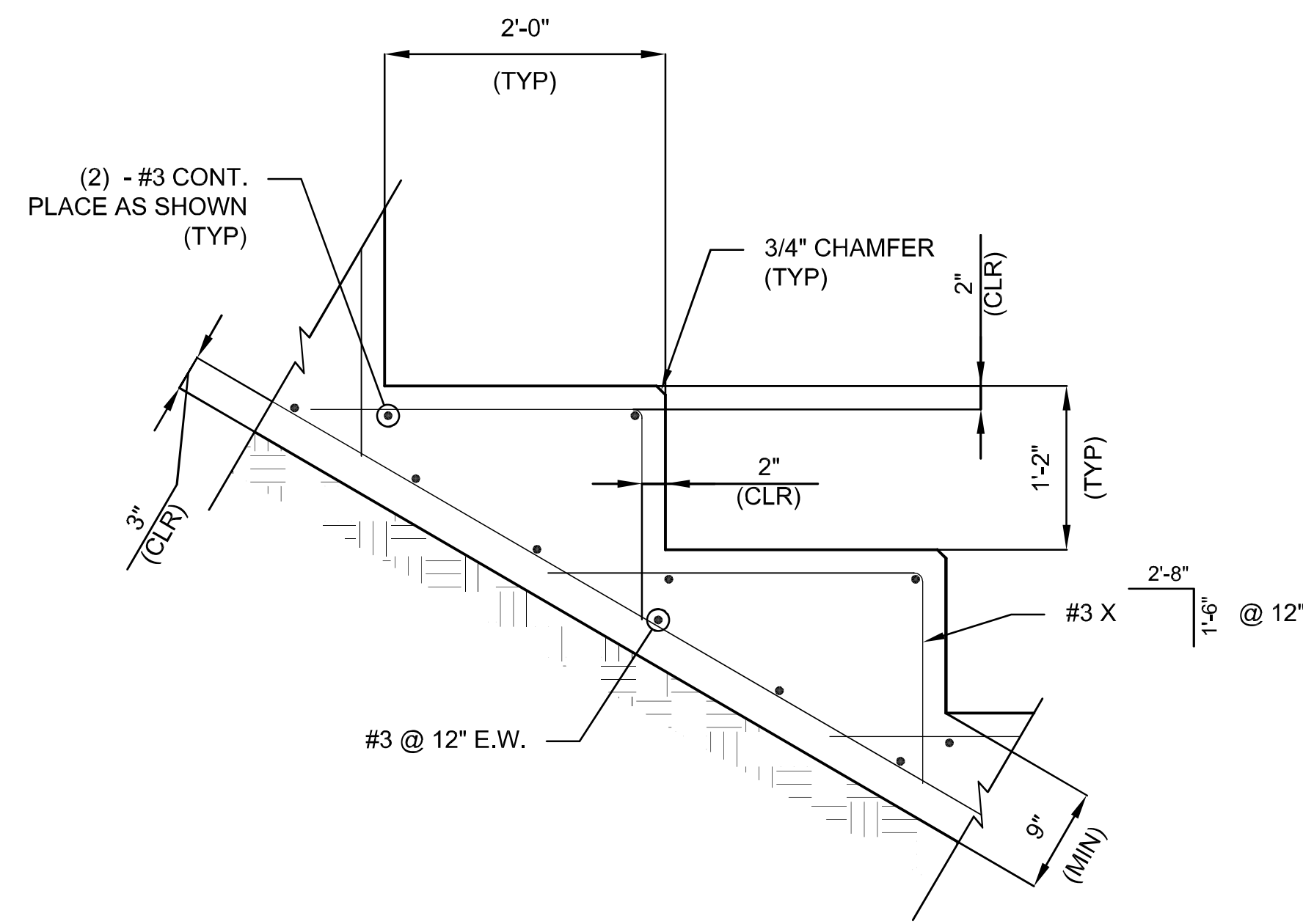

TYPICAL STEP SECTION

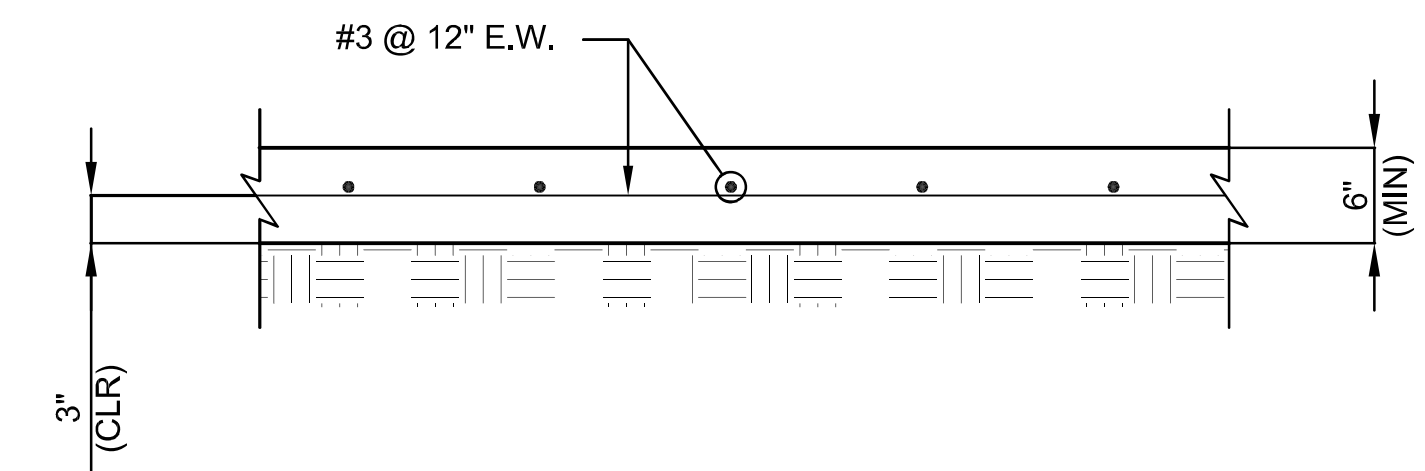

TYPICAL STILLING BASIN SECTION

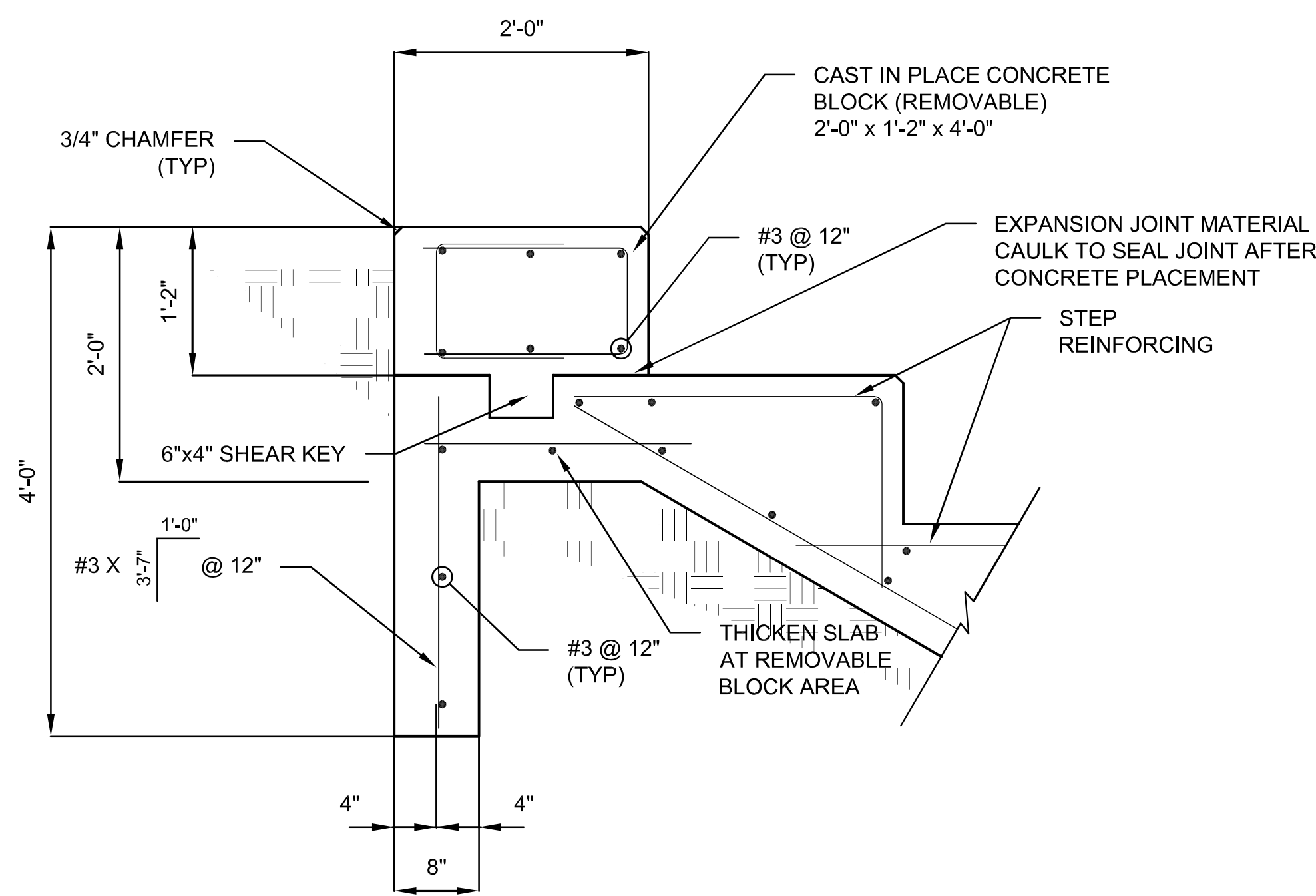

SECTION AT CUTOFF WALL AT REMOVABLE CONCRETE BLOCK

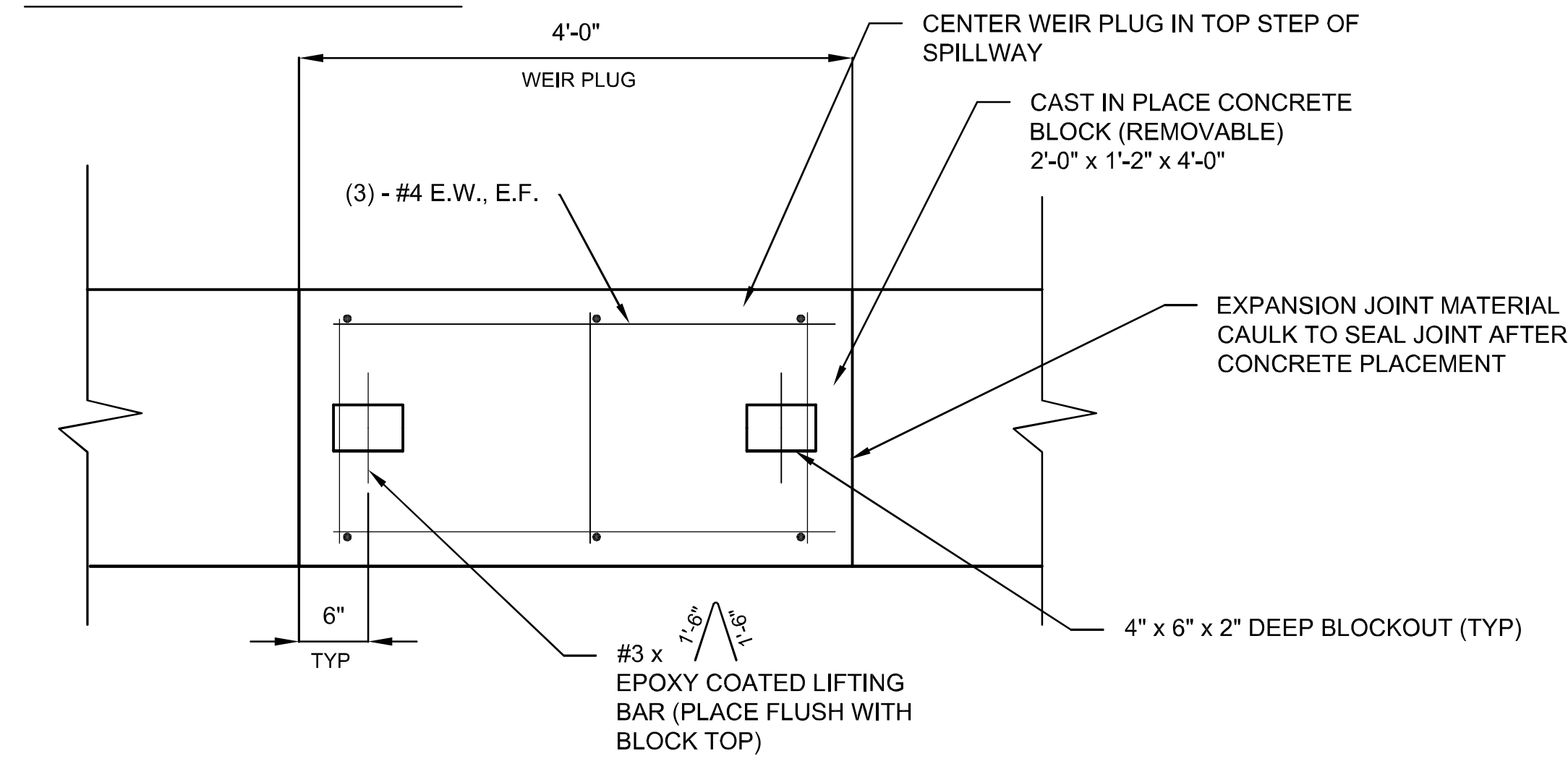

WALL AT REMOVABLE CONCRETE BLOCK - PLAN

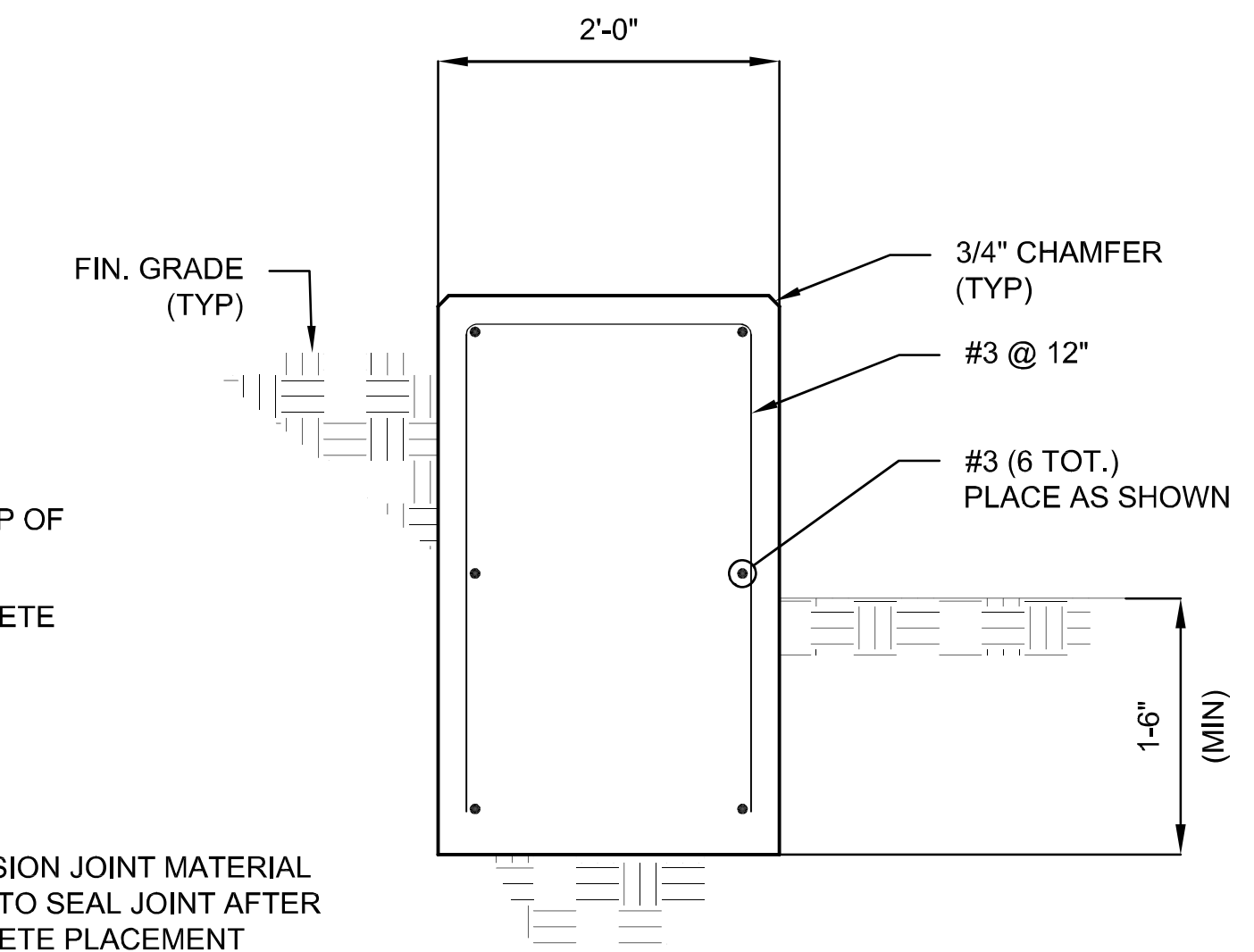

TYPICAL FINGER SECTION

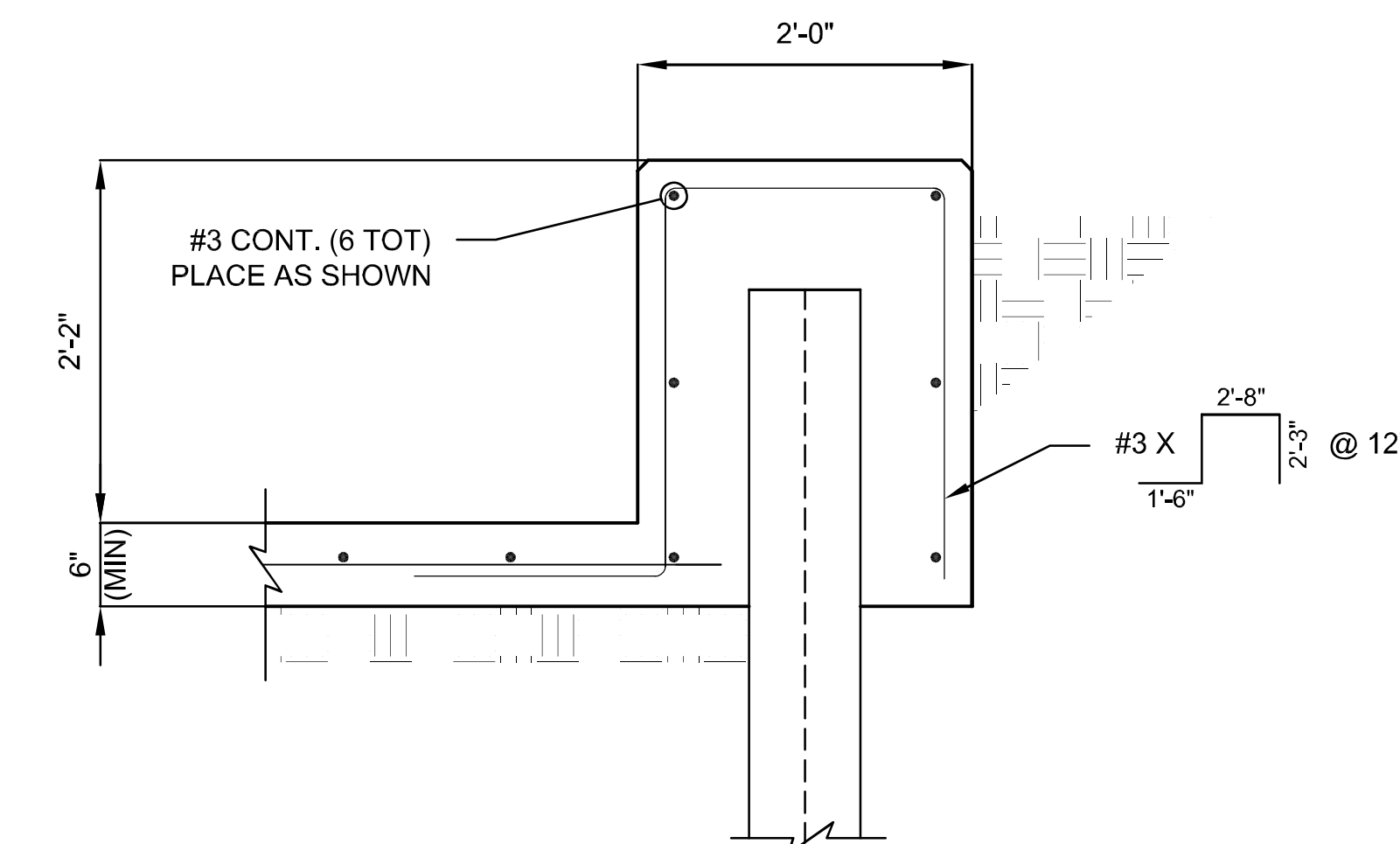

CUTOFF WALL CAP SECTION

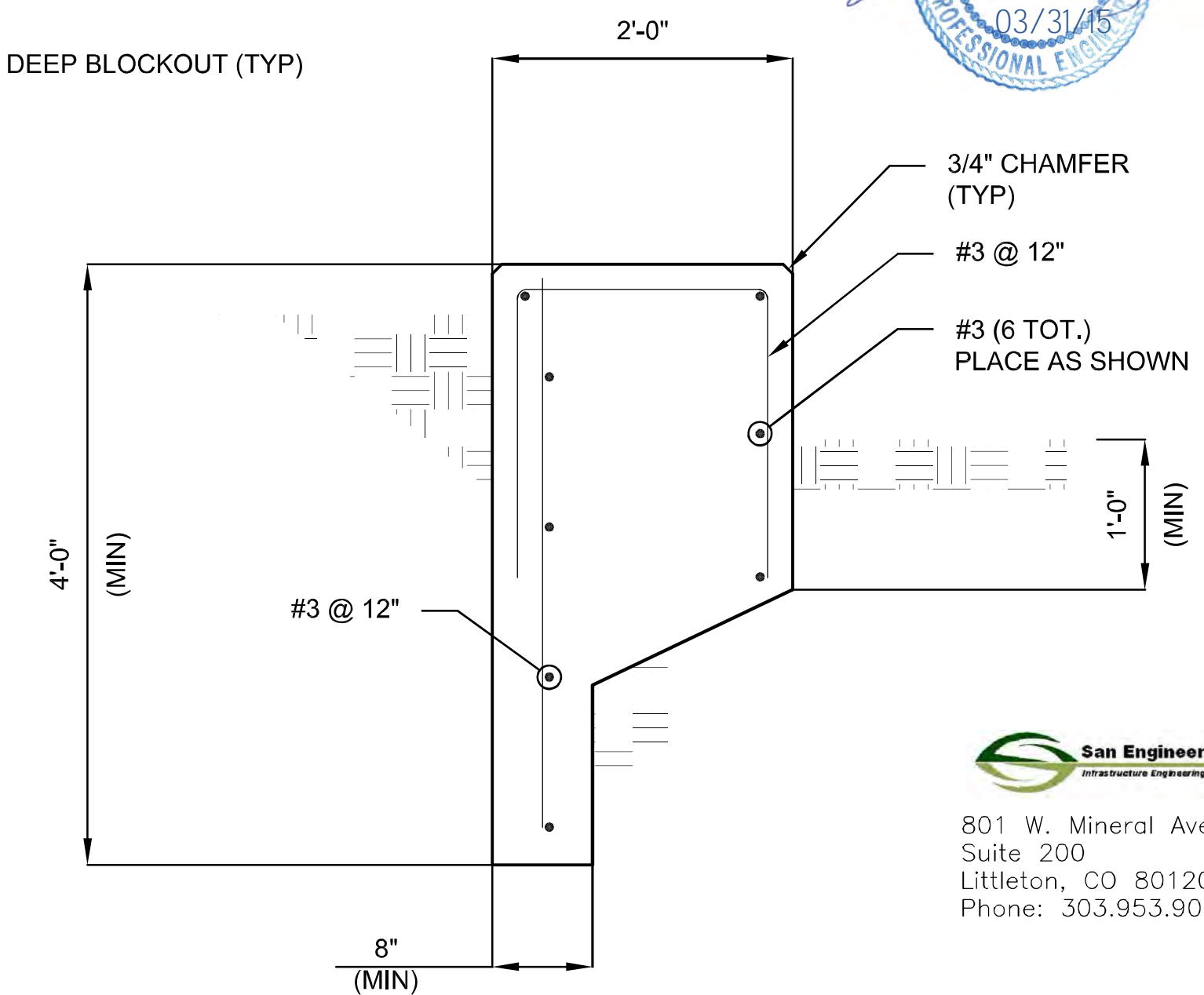

SECTION AT CUTOFF WALL

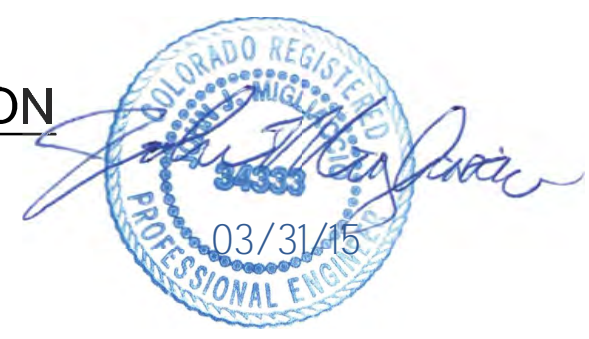

San Engineering LLC
801 W. Mineral Ave.
Suite 200
Littleton, CO 80120
Phone: 303.953.9014

Enginuity
Engineering Solutions
10106 W. San Juan Way
Suite 215
Littleton, CO 80127
Phone: 303.872.9112
Fax: 303.872.9104

NO.	DESCRIPTION OF REVISIONS	DATE	BY

CALL UNCC
TWO WORKING DAYS
BEFORE YOU DIG
1-800-922-1987
UTILITY LOCATION CENTER OF
COLORADO



CITY AND COUNTY OF DENVER
DEPARTMENT OF PUBLIC WORKS
ENGINEERING DIVISION
CAPITAL PROJECTS MANAGEMENT
2000 W. 3RD AVE. DENVER, CO 80223
TEL.: (303) 446-3617 FAX: (303) 446-3647

HAMPDEN HEIGHTS STORM SEWER
IMPROVEMENTS - PHASE III
E. GIRARD AVE. OUTFALL
PCO CONTROL NO: PWC2009-5013
PILAR REVIEW NO: 2011-0426-01
SPILLWAY STRUCTURAL DETAILS

DRAWN BY:	JWS
DESIGNED BY:	JWS
APPROVED BY:	DJJ
DRAWING NAME:	Hampden Heights - Structural Details.dwg
DATE:	03/18/15
SHEET NO.:	10 of 32

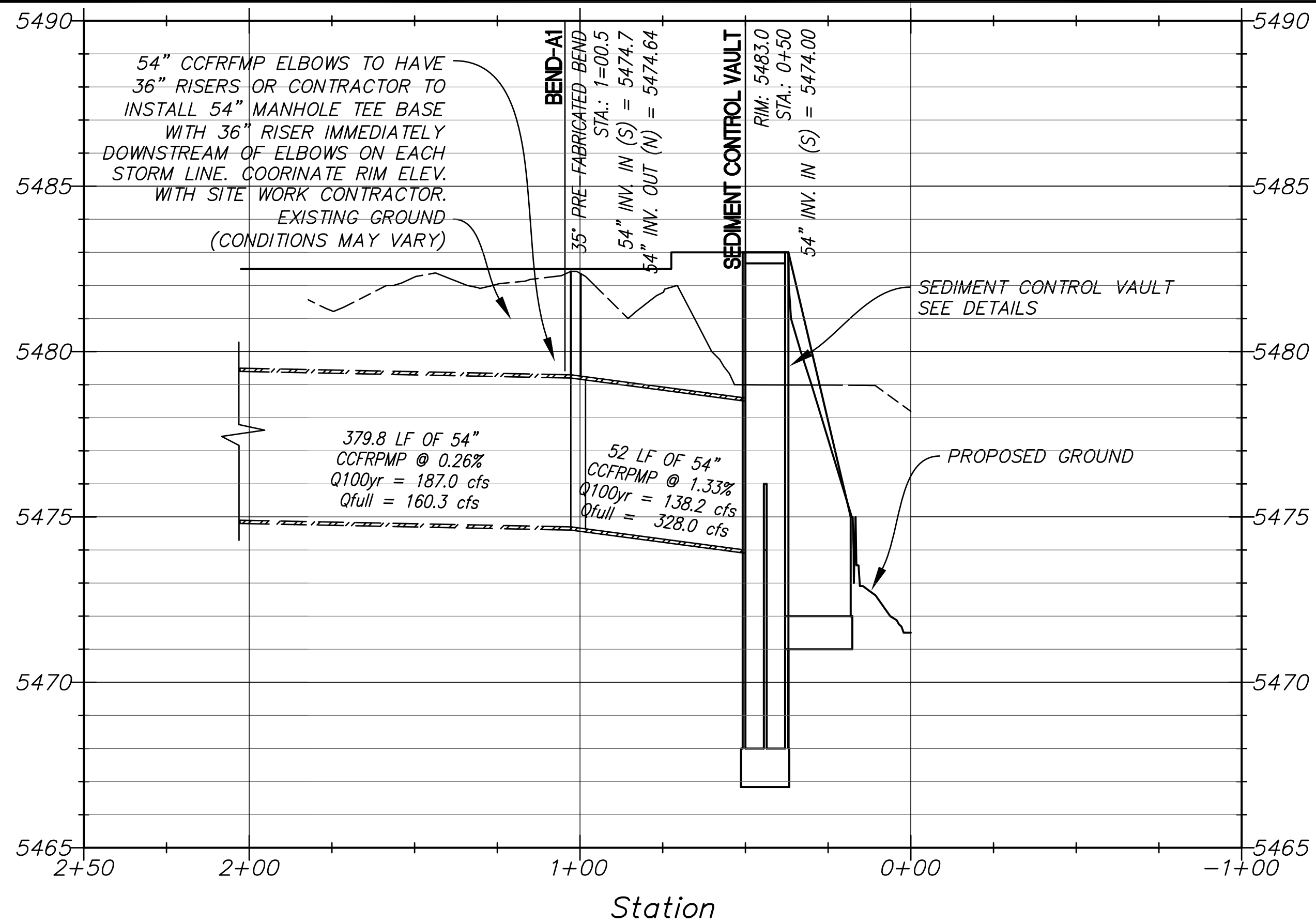

Line A - 54 Inch Realignment (West) PROFILE

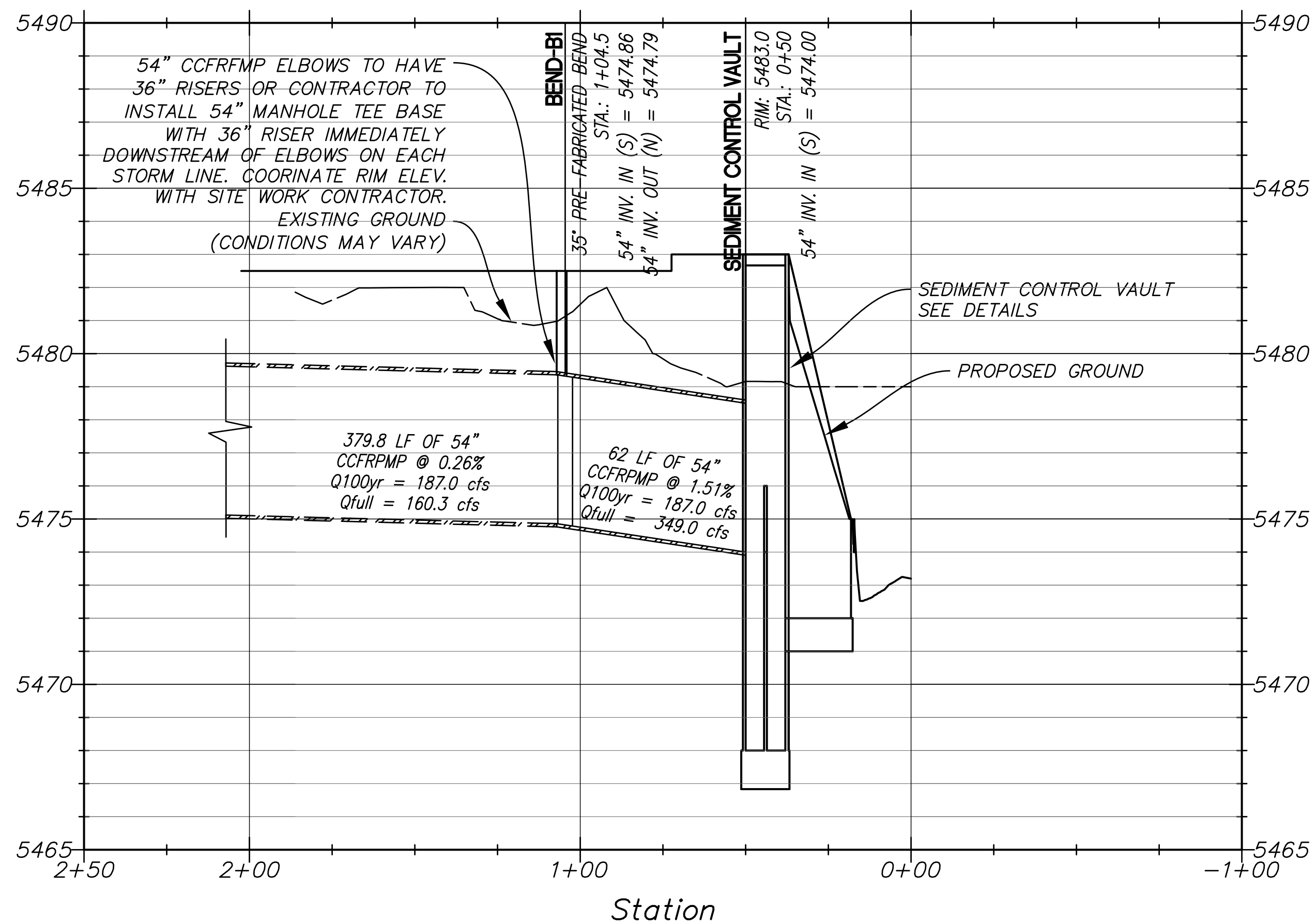

Line B - 54 Inch Realignment (East) PROFILE

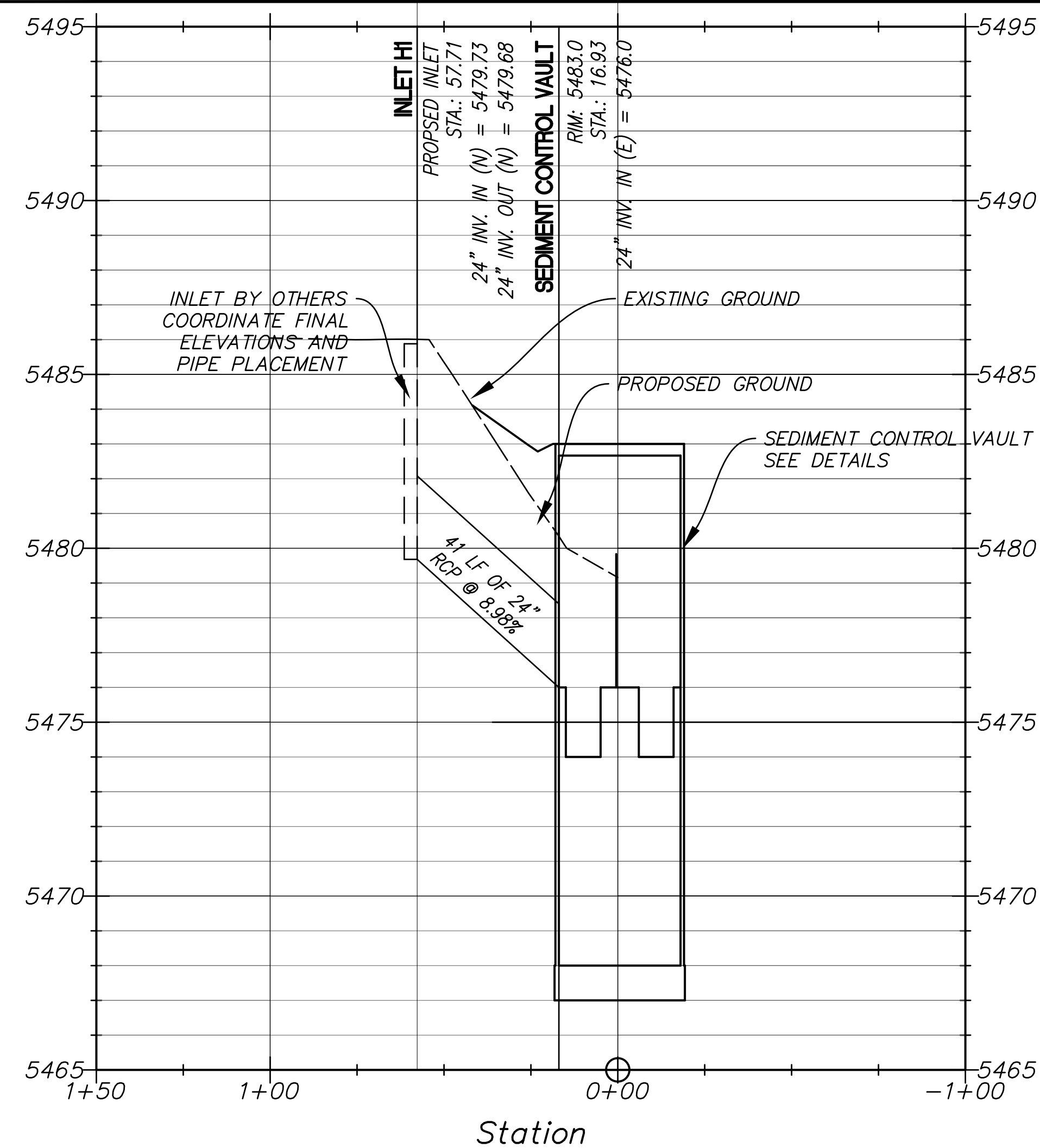

24 Inch Hampden Ave Lateral PROFILE

NO.	DESCRIPTION OF REVISIONS	DATE	BY

CALL UNCC
TWO WORKING DAYS
BEFORE YOU DIG



1-800-922-1987
UTILITY LOCATION CENTER

CITY AND COUNTY OF DENVER
DEPARTMENT OF PUBLIC WORKS
ENGINEERING DIVISION
CAPITAL PROJECTS MANAGEMENT
2000 W. 3RD AVE. DENVER, CO 80223
TEL.: (303) 446-3617 FAX: (303) 446-3647

HAMPDEN HEIGHTS STORM SEWER
IMPROVEMENTS - PHASE III
E. GIRARD AVE. OUTFALL
PCO CONTROL NO: PWC2009-5013
PILAR REVIEW NO: 2011-0426-01
STORM DRAIN PROFILES

DRAWN BY:	JWS
DESIGNED BY:	JWS
APPROVED BY:	DJJ
DRAWING NAME:	DesignMaster Working.dwg
DATE:	03/18/15
SHEET NO.:	11 of 32



Enginity
Engineering Solutions

10106 W. San Juan Way
Suite 215
Littleton, CO 80127
Phone: 303.872.9112
Fax: 303.872.9104

C:\ENGINEERING\PROJECTS\DENVER\13-006_HAMPDEN_HEIGHTS_PHASE_II_OUTFALL\CADD\PLANS\MASTER DESIGN\DESIGNMASTER\WORKING\031815.dwg

C:\ENGINEERING\PROJECTS\DENVER\13-006 HAMPDEN HEIGHTS PHASE II OUTFALL\CADD\PLANS\MASTER DESIGN\MASTERWORK\PHASE2\March 30, 2015

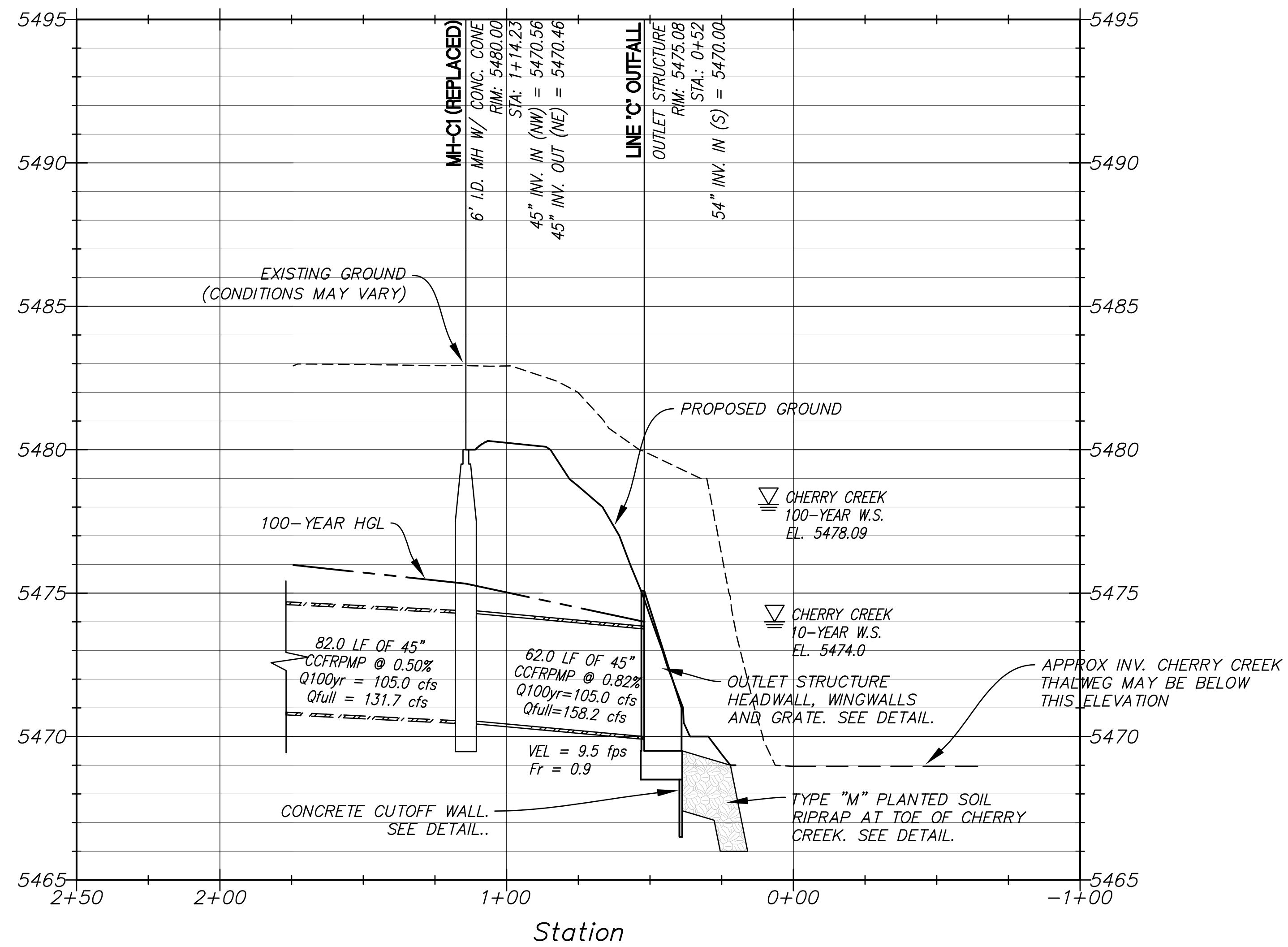

Line C - 45 Inch Realignment (North) PROFILE

NO.	DESCRIPTION OF REVISIONS	DATE	BY

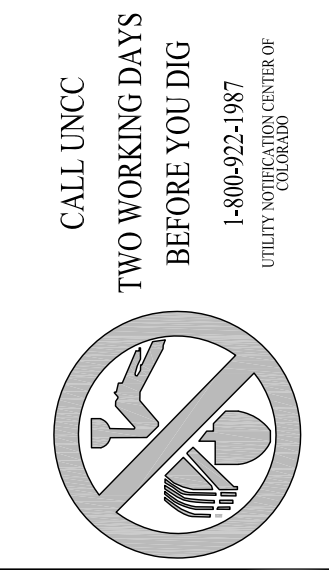

CITY AND COUNTY OF DENVER
 DEPARTMENT OF PUBLIC WORKS
 ENGINEERING DIVISION
 CAPITAL PROJECTS MANAGEMENT
 2000 W. 3RD AVE. DENVER, CO 80223
 TEL.: (303) 446-3617 FAX: (303) 446-3647

HAMPDEN HEIGHTS STORM SEWER
 IMPROVEMENTS - PHASE III
 E. GIRARD AVE. OUTFALL
 PCO CONTROL NO: PWC2009-5013
 PILAR REVIEW NO: 2011-0426-01
 STORM DRAIN PROFILES

DRAWN BY:	JWS
DESIGNED BY:	JWS
APPROVED BY:	DJJ
DRAWING NAME:	DesignMaster Working.dwg
DATE:	03/18/15
SHEET NO.:	12 of 32



Enginuity
 Engineering Solutions
 10106 W. San Juan Way
 Suite 215
 Littleton, CO 80127
 Phone: 303.872.9112
 Fax: 303.872.9104

PLOT DATE: March 30, 2015

C:\ENGINEERING\PROJECTS\DENVER\13-006_HAMPDEN HEIGHTS PHASE II OUTFALL\CADD\PLANS\DETAILS\SEDIMENTATION_STRUCTURE.DWG

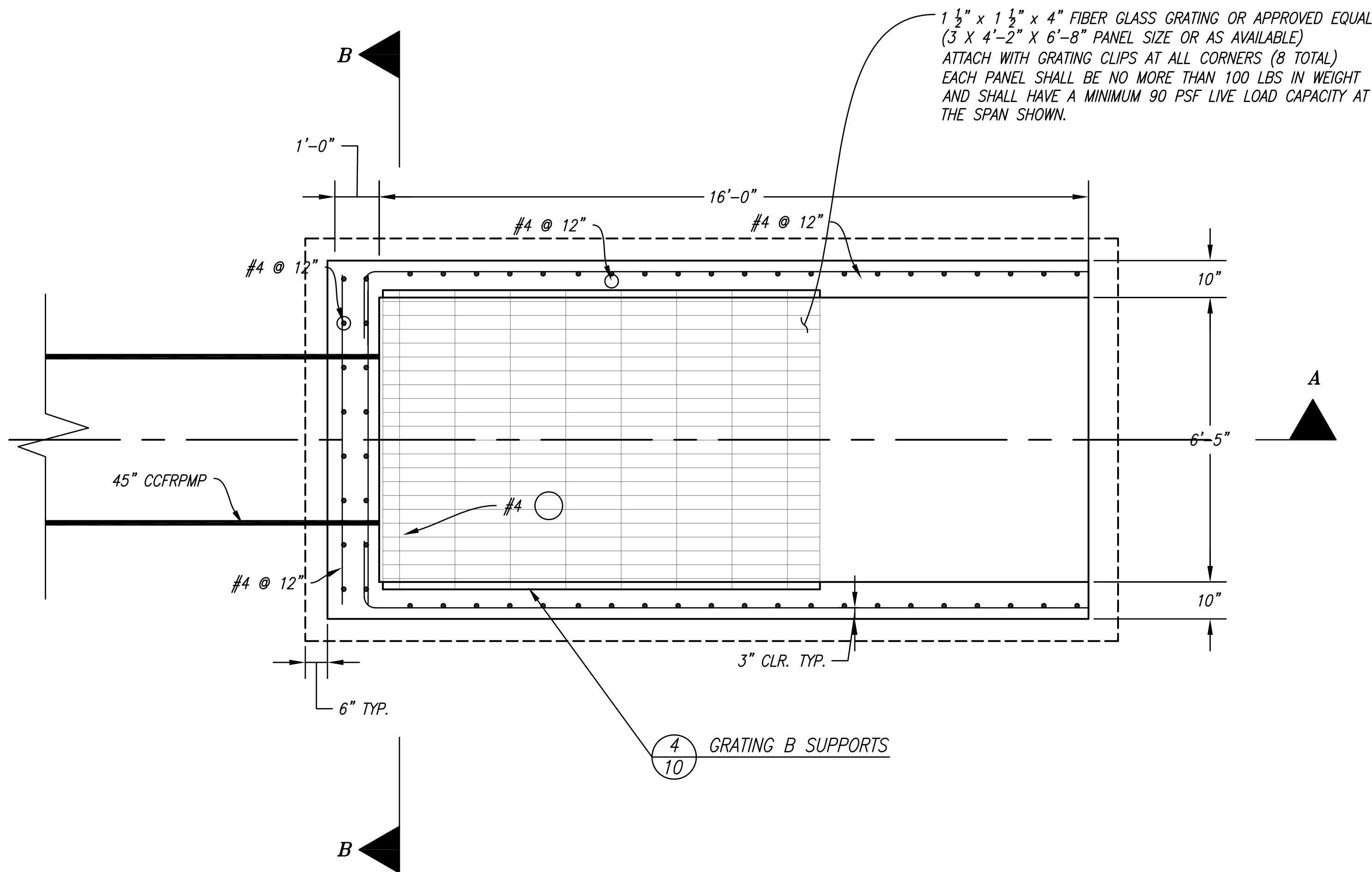

1 LINE "C" OUTLET STRUCTURE - PLAN 1"=2'

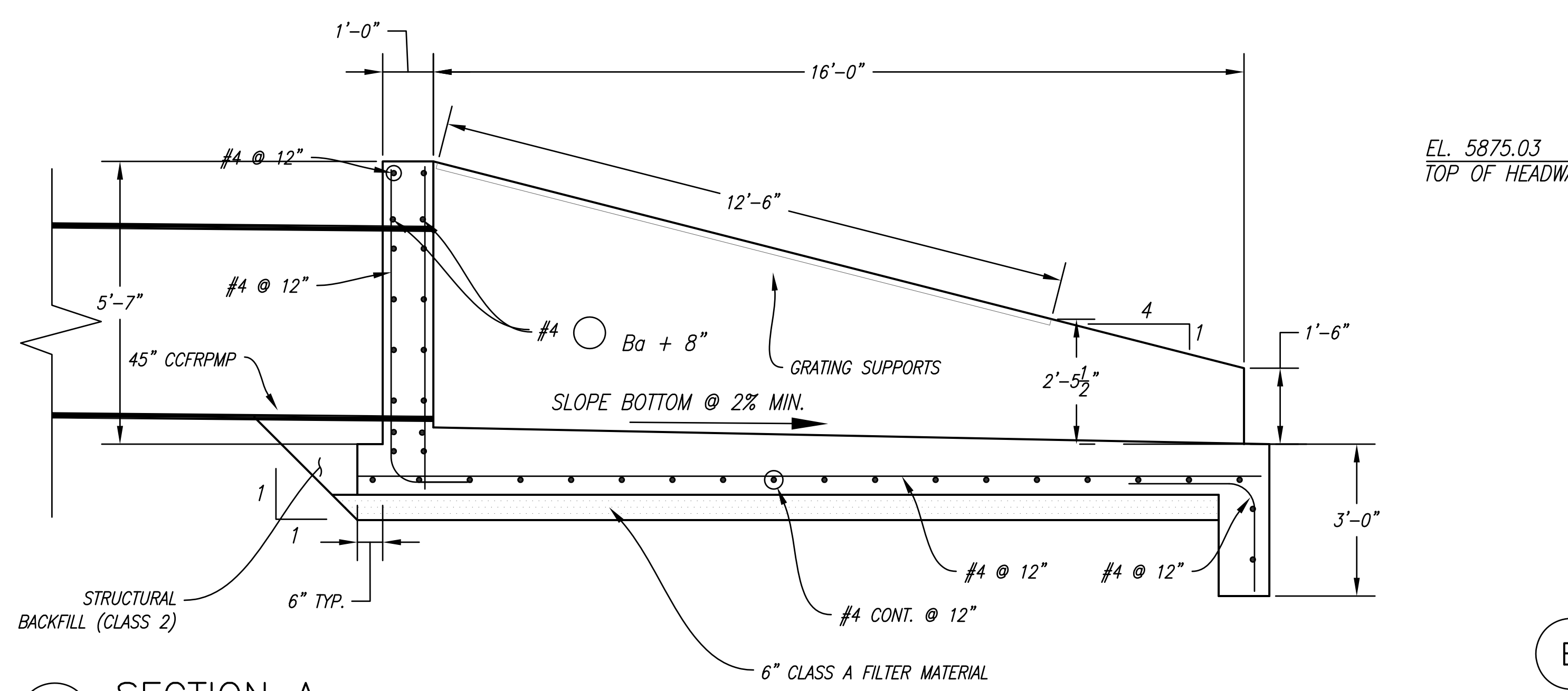

A SECTION A 1"=2'

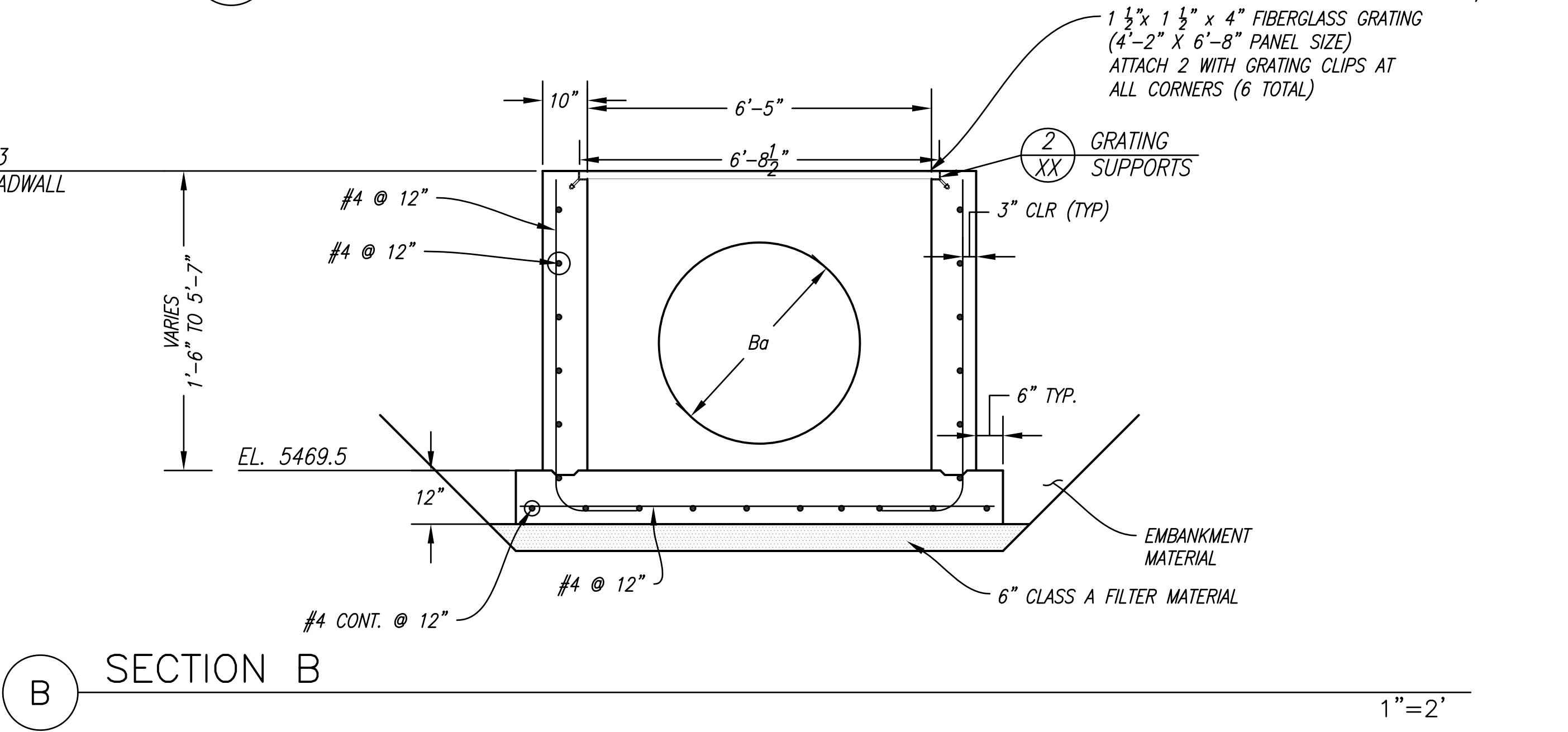

B SECTION B 1"=2'

2 GRATING PANEL SUPPORT 1/2"=1'

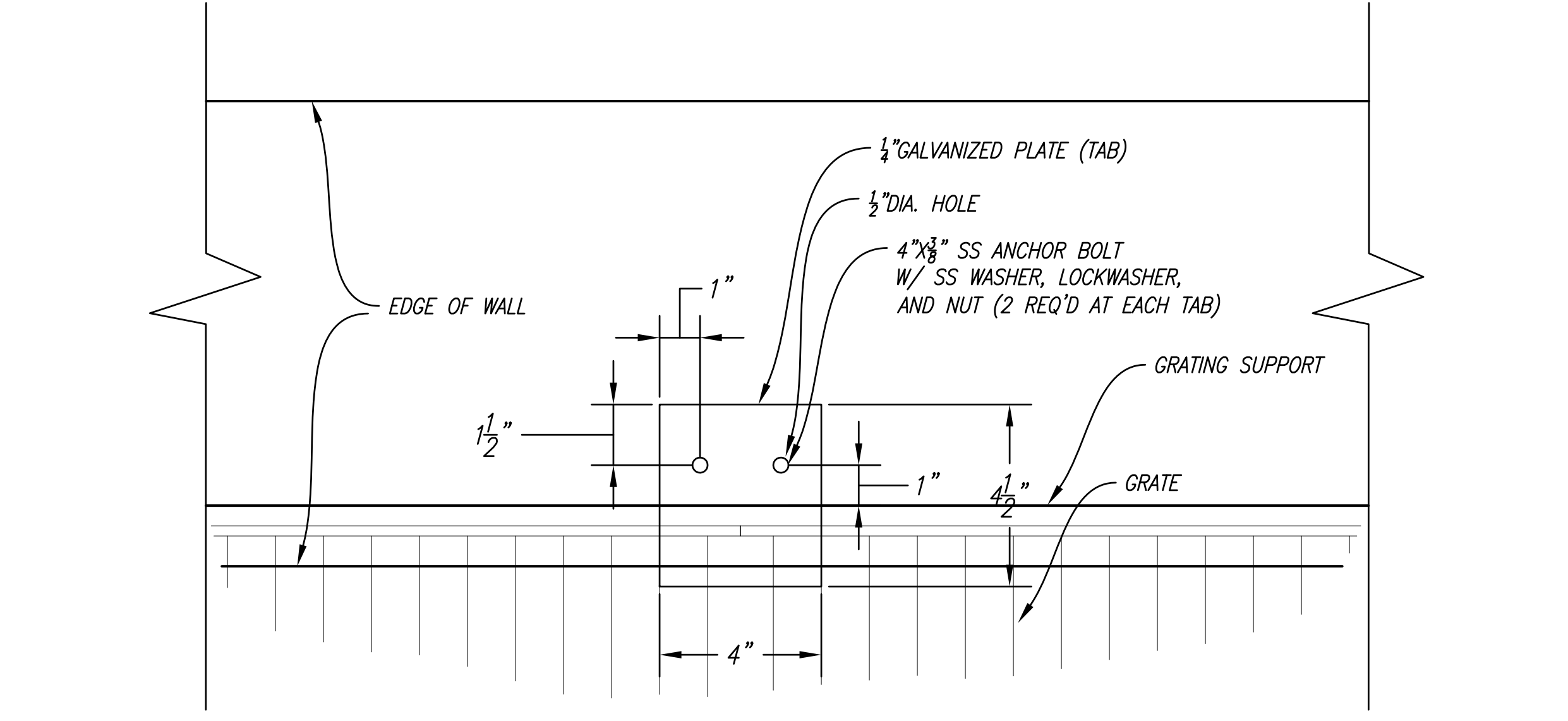

3 GRATE RESTRAINTS 1/4"=1'

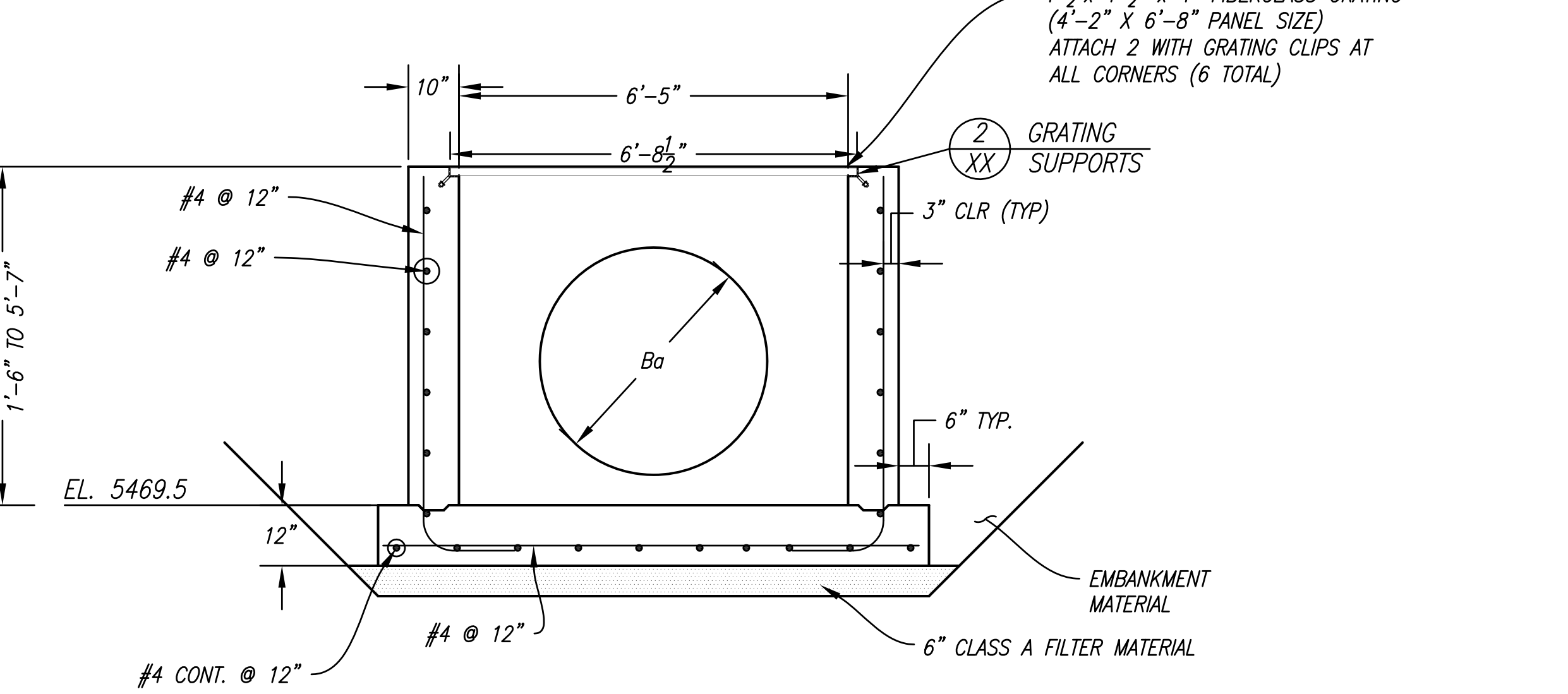

NO.	DESCRIPTION OF REVISIONS	DATE	BY

CALL UNCC
TWO WORKING DAYS
BEFORE YOU DIG
1-800-922-1987
UTILITY WORKER CENTER FOR
SAFETY

CITY AND COUNTY OF DENVER
DEPARTMENT OF PUBLIC WORKS
ENGINEERING DIVISION
CAPITAL PROJECTS MANAGEMENT
2000 W. 3RD AVE. DENVER, CO 80223
TEL.: (303) 446-3617 FAX: (303) 446-3647

HAMPDEN HEIGHTS STORM SEWER
IMPROVEMENTS - PHASE III
E. GIRARD AVE. OUTFALL
PCO CONTROL NO: PWC2009-5013
PILAR REVIEW NO: 2011-0426-01
STORM DRAIN OUTLET DETAILS

DRAWN BY: JWS
DESIGNED BY: JWS
APPROVED BY: DJJ
DRAWING NAME: Sedimentation Structure.dwg
DATE: 03/18/15
SHEET NO.: 13 of 32

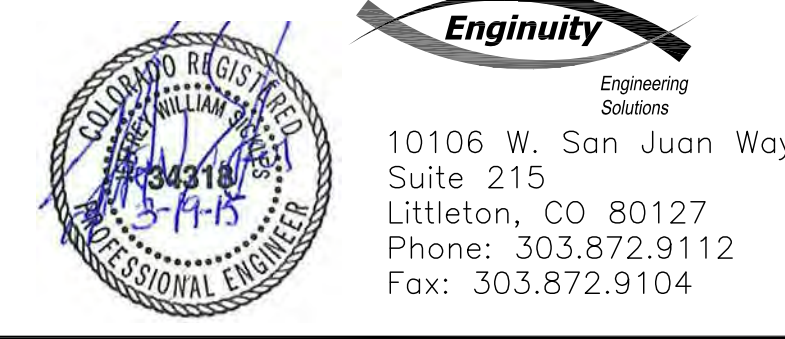

Enginuity
Engineering Solutions
10106 W. San Juan Way
Suite 215
Littleton, CO 80127
Phone: 303.872.9112
Fax: 303.872.9104

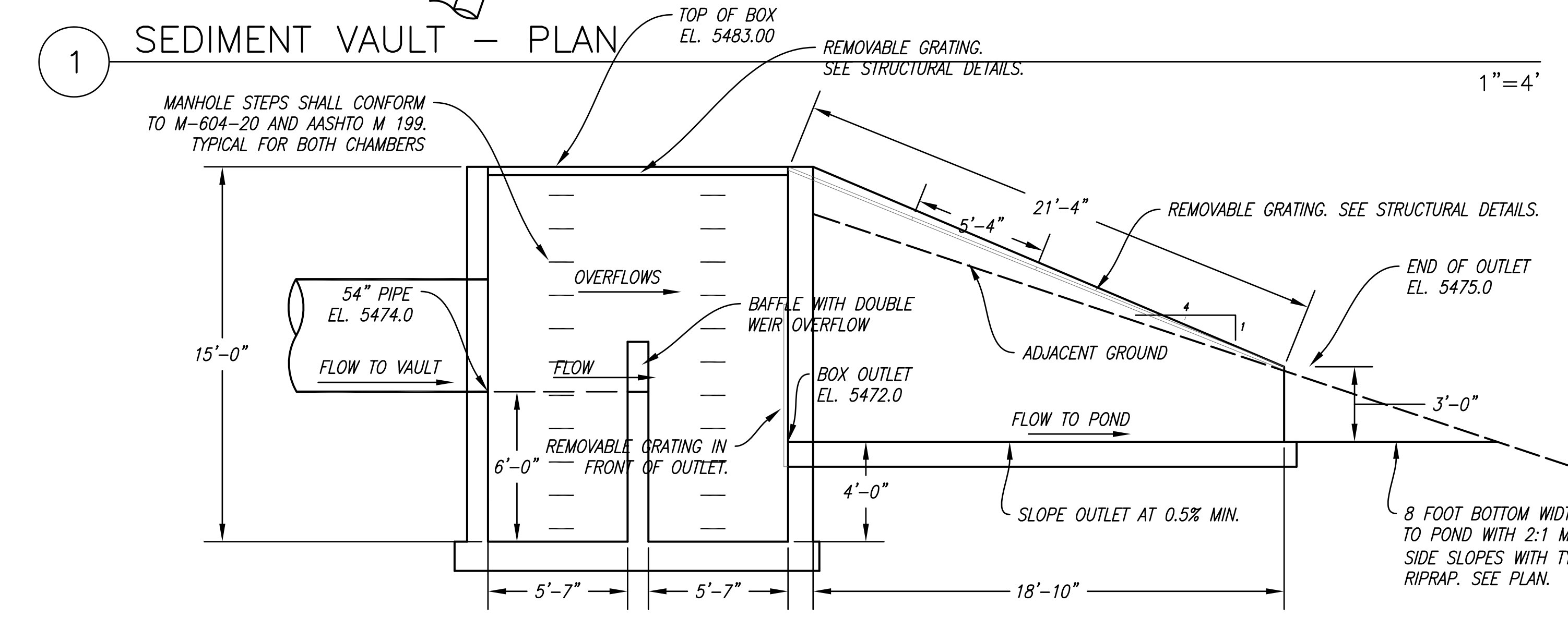
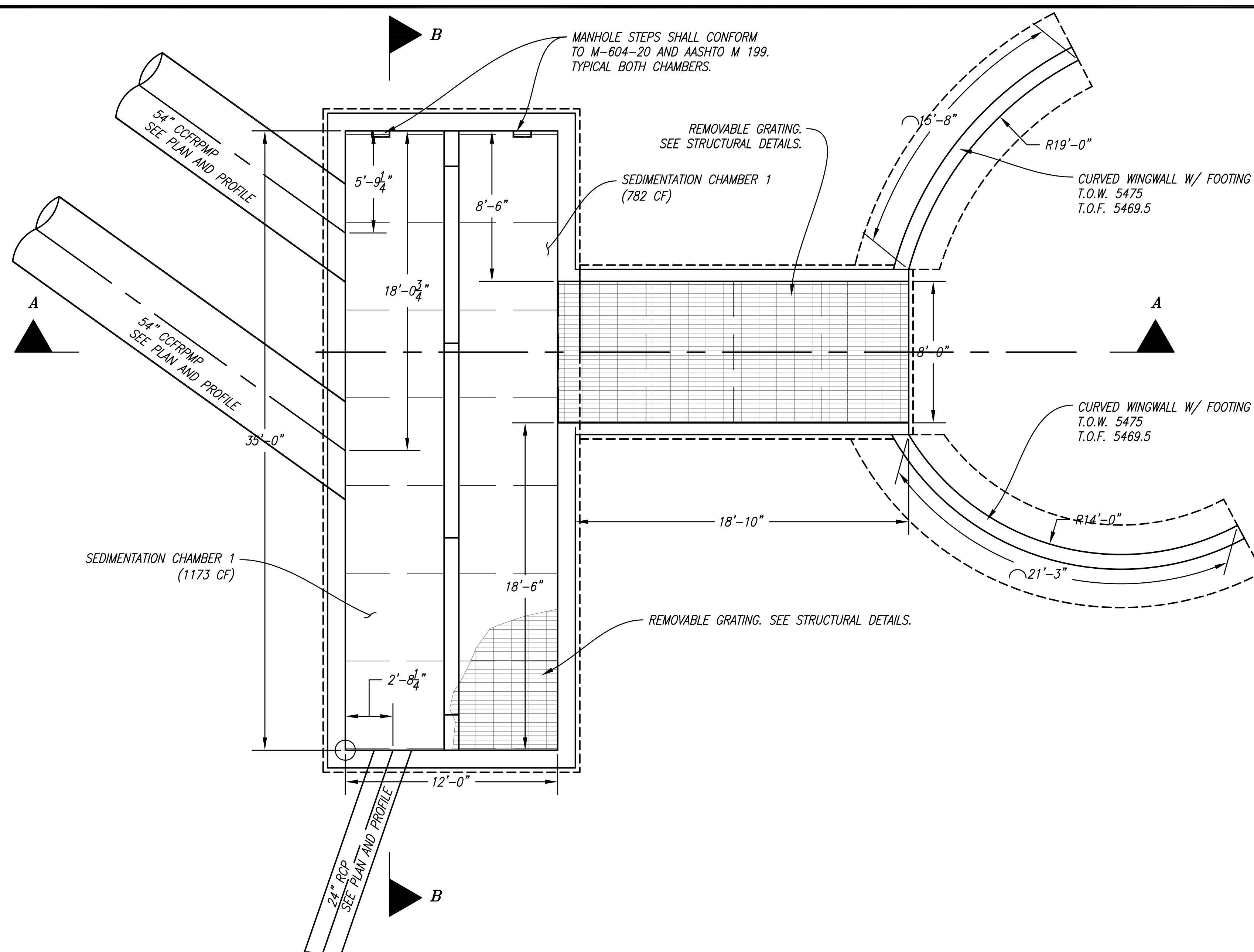

A SEDIMENT VAULT - SECTION A
1"=4'

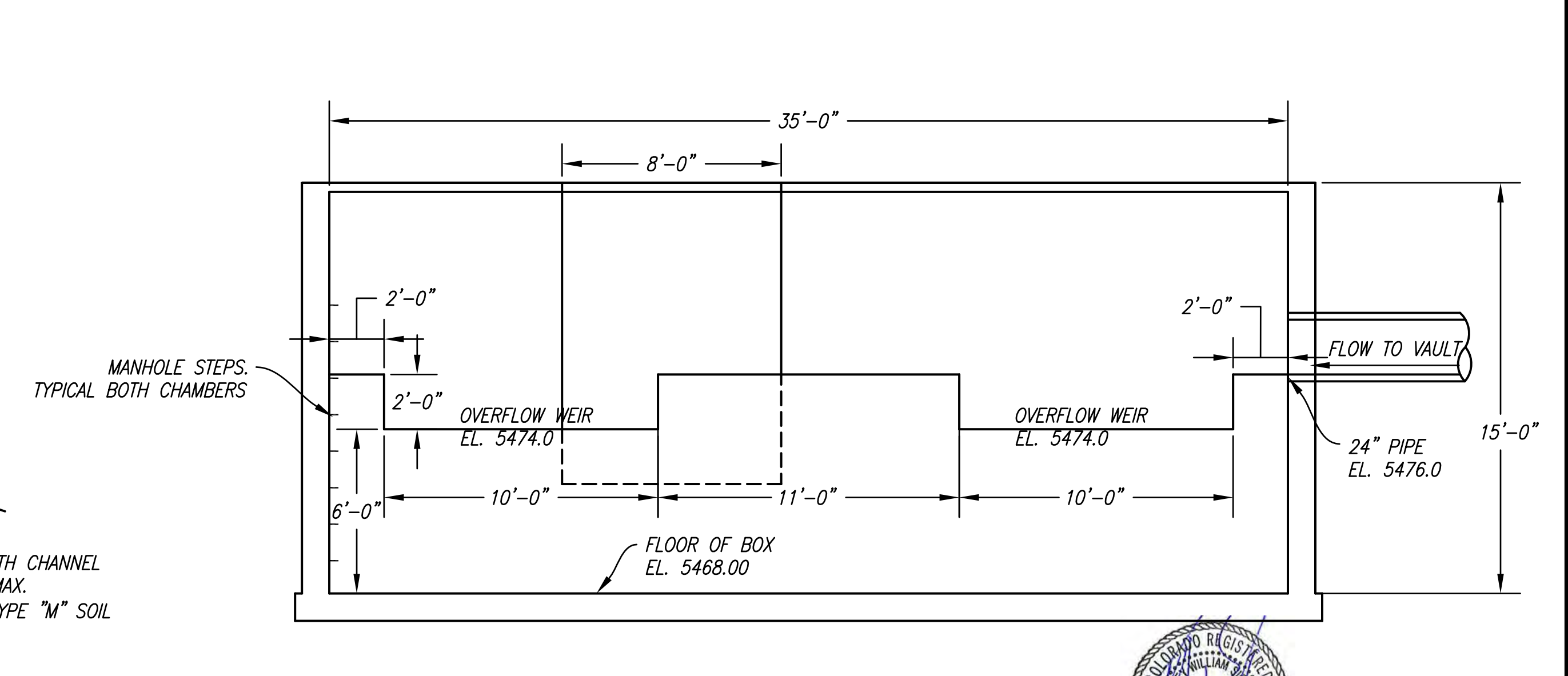

B SEDIMENT VAULT - SECTION B
1"=4'

NO.	DESCRIPTION OF REVISIONS	DATE	BY

CALL UNCC
TWO WORKING DAYS
BEFORE YOU DIG
1-800-922-1987
UTILITY LOCATION CENTER OF COLORADO

CITY AND COUNTY OF DENVER
DEPARTMENT OF PUBLIC WORKS
ENGINEERING DIVISION
CAPITAL PROJECTS MANAGEMENT
2000 W. 3RD AVE. DENVER, CO 80223
TEL.: (303) 446-3617 FAX: (303) 446-3647

HAMPDEN HEIGHTS STORM SEWER
IMPROVEMENTS - PHASE III
E. GIRARD AVE. OUTFALL
PCO CONTROL NO:
PILAR REVIEW NO:

SEDIMENT VAULT GENERAL LAYOUT PLAN

DRAWN BY:	JWS
DESIGNED BY:	JWS
APPROVED BY:	DJJ
DRAWING NAME:	Sedimentation Structure.dwg
DATE:	03/18/15
SHEET NO.:	14 of 32

C:\ENGINITY\PROJECTS\DENVER\13-006_HAMPDEN HEIGHTS PHASE II OUTFALL\CADD\PLANS\DETAILS\SEDIMENTATION STRUCTURE\DWG: March 30, 2015

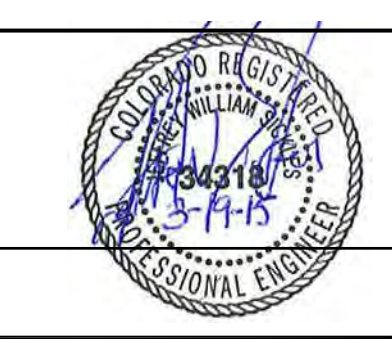

PLOT DATE: March 31, 2015

Z:\PROJECTS\2014\06\022 (HAMPDEN HEIGHTS)\HAMPDEN HEIGHTS - STRUCTURAL DETAILS 10-17-14.dwg

STRUCTURAL STEEL NOTES

1. GALVANIZE STEEL UNLESS NOTED OTHERWISE. STEEL W SHAPES SHALL CONFORM TO ASTM A992, OR ASTM A-572 GRADE 50.
2. STRUCTURAL TUBING MEMBERS SHALL CONFORM TO ASTM A500, GRADE B, AND PIPE ASTM A53, GRADE B.
3. BOLTS SHALL CONFORM TO ASTM 325, TYPE 1, HEAVY HEX. NUTS SHALL CONFORM TO ASTM A563. WASHERS SHALL CONFORM TO ASTM FINISH SHALL BE HOT DIPPED GALVANIZED.
4. ALL WELDING SHALL BE DONE USING E70XX ELECTRODES AND WELDING SHALL CONFORM TO AISC AND AWS D1.1. WHERE FILLET WELD SIZES ARE NOT SHOWN, PROVIDE THE MINIMUM SIZE PER TABLE J2.4 IN THE AISC "MANUAL OF STEEL CONSTRUCTION" 13TH EDITION.
5. STRUCTURAL STEEL BEAMS, COLUMNS, AND CONNECTIONS SHALL BE DETAILED, FABRICATED, AND ERECTED IN ACCORDANCE WITH AISC MANUAL OF STEEL CONSTRUCTION, ALLOWABLE STRESS DESIGN, NINTH EDITION (INCLUDING AISC CODE OF STANDARD PRACTICE FOR STEEL BUILDINGS AND BRIDGES).
6. WHEN WELDING TO EXISTING STEEL, PAINT AND/OR GALVANIZING SHALL BE GROUND OFF BEFORE WELDING AND SHALL BE REAPPLIED AFTER WELDING.
7. HOLLOW STRUCTURAL STEEL TUBES SHALL BE FABRICATED WITH WEEP HOLES AT LOW ENDS FOR DRAINAGE.
7. CONTRACTOR SHALL SUBMIT SHOP DRAWINGS FOR APPROVAL PRIOR TO CONSTRUCTION.

CONCRETE NOTES

1. ALL CONCRETE WORK SHALL BE IN ACCORDANCE WITH THE LATEST VERSION OF ACI 318, ACI 304, AND ACI 315.
2. ALL CONCRETE SHALL HAVE A MINIMUM COMPRESSIVE STRENGTH OF 4,500 PSI AT 28 DAYS WITH 4-6% ENTRAINED AIR AND TYPE II CEMENT UNLESS NOTED OTHERWISE.
3. REINFORCING STEEL SHALL CONFORM TO ASTM A 615, GRADE 60, DEFORMED UNLESS OTHERWISE NOTED. WELDED WIRE FABRIC SHALL CONFORM TO ASTM A 185 WELDED STEEL WIRE FABRIC UNLESS NOTED OTHERWISE. SPLICES SHALL BE CLASS "B". ALL HOOKS SHALL BE STANDARD UNLESS NOTED OTHERWISE.
4. THE FOLLOWING MINIMUM CONCRETE COVER SHALL BE PROVIDED FOR REINFORCING STEEL UNLESS SHOWN OTHERWISE ON DRAWINGS:
 CONCRETE CAST AGAINST EARTH = 3 IN
 CONCRETE EXPOSED TO EARTH OR WEATHER:
 #6 AND LARGER = 2 IN
 #5 AND SMALLER & WWF = 1-1/2 IN
 CONCRETE NOT EXPOSED TO EARTH OR WEATHER NOR
 CAST AGAINST EARTH:
 SLAB AND WALL = 3/4 IN
 BEAMS AND COLUMNS = 1-1/2 IN
5. A 3/4" CHAMFER SHALL BE PROVIDED AT ALL EXPOSED EDGES OF CONCRETE UNLESS NOTED OTHERWISE IN ACCORDANCE WITH ACI 301 SECTION 4.2.4.
6. HOLES TO RECEIVE EXPANSION/WEDGE ANCHORS SHALL BE 1/8" LARGER IN DIAMETER THAN THE ANCHOR-BOLT, DOWEL OR ROD AND SHALL CONFORM TO MANUFACTURER'S RECOMMENDATION FOR EMBEDMENT DEPTH OR AS SHOWN ON THE DRAWINGS. LOCATE AND AVOID CUTTING EXISTING REBAR WHEN DRILLING HOLES IN ELEVATED CONCRETE SLABS.
7. USE AND INSTALLATION OF CONCRETE EXPANSION/WEDGE ANCHORS SHALL BE PER ICBO & MANUFACTURER'S WRITTEN RECOMMENDED PROCEDURES.

STRUCTURAL SHEET INDEX

SHEET #	SHEET NAME
S01	STRUCTURAL NOTES
S02	VAULT WALL AND FRAMING PLANS
S03	VAULT WALL DETAILS
S04	VAULT WALL DETAILS
S05	VAULT FRAMING DETAILS
S06	SPILLWAY STRUCTURAL DETAILS

NO.	DESCRIPTION OF REVISIONS	DATE	BY

CALL UNCC
TWO WORKING DAYS
BEFORE YOU DIG
1-800-922-1987
UTILITY WORKING CENTER OF
COLORADO



CITY AND COUNTY OF DENVER
DEPARTMENT OF PUBLIC WORKS
ENGINEERING DIVISION
CAPITAL PROJECTS MANAGEMENT
2000 W. 3RD AVE. DENVER, CO 80223
TEL.: (303) 446-3617 FAX: (303) 446-3647

HAMPDEN HEIGHTS STORM SEWER
IMPROVEMENTS - PHASE III
E. GIRARD AVE. OUTFALL
PCO CONTROL NO:
PILAR REVIEW NO:
STRUCTURAL GENERAL NOTES



801 W. Mineral Ave.
Suite 200
Littleton, CO 80120
Phone: 303.953.9014



10106 W. San Juan Way
Suite 215
Littleton, CO 80127
Phone: 303.872.9112
Fax: 303.872.9104

DRAWN BY:	JM
DESIGNED BY:	JM
APPROVED BY:	JWS
DRAWING NAME:	Hampden Heights - Structural Details 10-17-14.dwg
DATE:	03/31/15
SHEET NO.:	15 of 32

Z:\PROJECTS\2014_106_002 (HAMPDEN HEIGHTS) - STRUCTURAL DETAILS - 10-17-14.DWG PLOT DATE: March 31, 2015

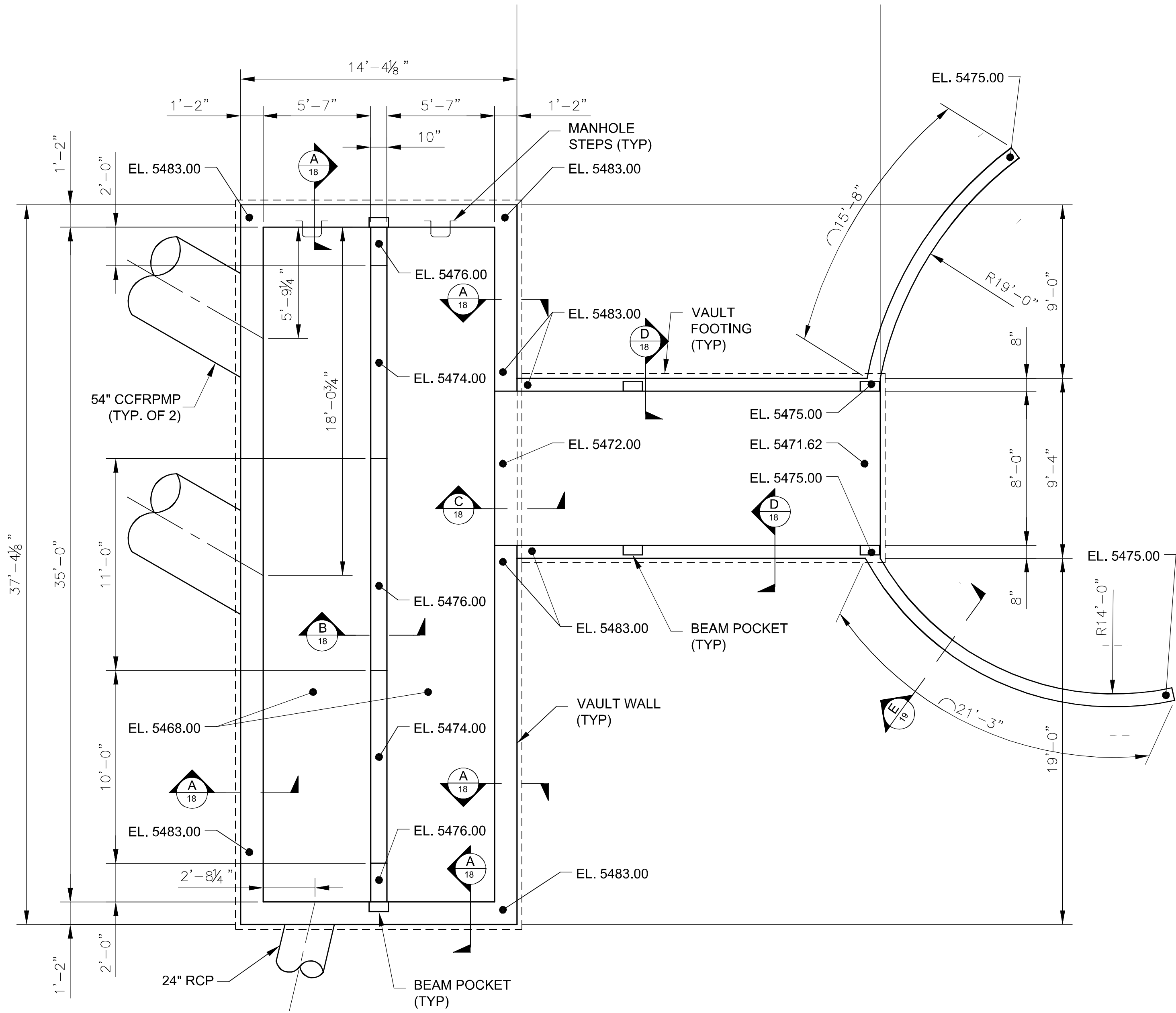

VAULT WALL PLAN

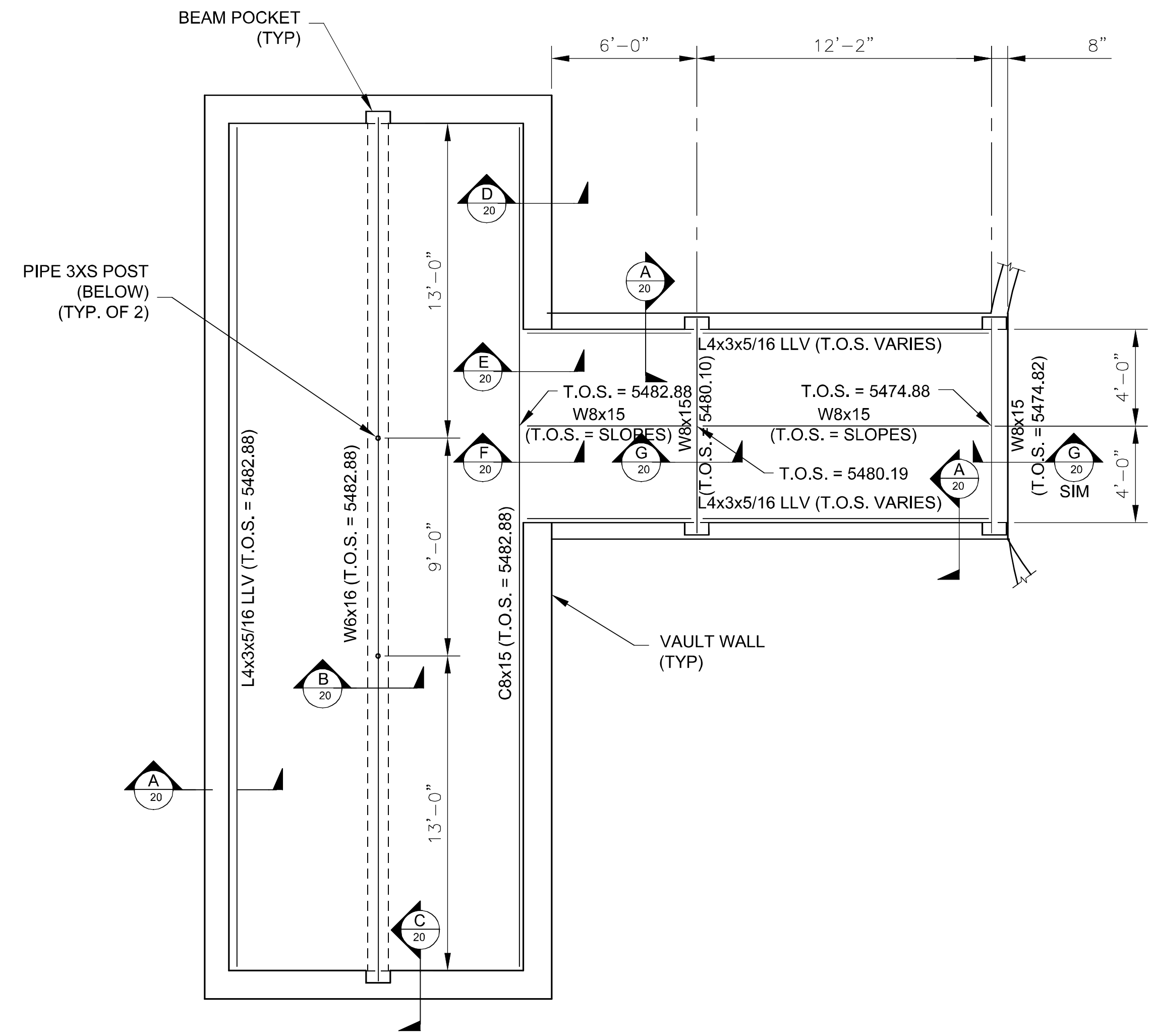

VAULT FRAMING PLAN



San Engineering LLC
Civil and Structural Engineering
801 W. Mineral Ave.
Suite 200
Littleton, CO 80120
Phone: 303.953.9014

Enginuity
Engineering Solutions
10106 W. San Juan Way
Suite 215
Littleton, CO 80127
Phone: 303.872.9112
Fax: 303.872.9104

NO.	DESCRIPTION OF REVISIONS	DATE	BY

CALL UNCC
TWO WORKING DAYS
BEFORE YOU DIG
1-800-922-1887
UTILITY SERVICE CENTER OF
COLORADO

CITY AND COUNTY OF DENVER
DEPARTMENT OF PUBLIC WORKS
ENGINEERING DIVISION
CAPITAL PROJECTS MANAGEMENT
2000 W. 3RD AVE. DENVER, CO 80223
TEL.: (303) 446-3617 FAX: (303) 446-3647

HAMPDEN HEIGHTS STORM SEWER
IMPROVEMENTS - PHASE III
E. GIRARD AVE. OUTFALL
PCO CONTROL NO:
PILAR REVIEW NO:
VAULT STRUCTURAL LAYOUT PLAN

DRAWN BY:	JM
DESIGNED BY:	JM
APPROVED BY:	JWS
DRAWING NAME:	Hampden Heights - Structural Details 10-17-14.dwg
DATE:	03/31/15
SHEET NO.:	16 of 32

PLOT DATE: March 31, 2015

Z:\PROJECTS\2014\106\002 (HAMPDEN HEIGHTS)\HAMPDEN HEIGHTS - STRUCTURAL DETAILS 10-17-14.DWG

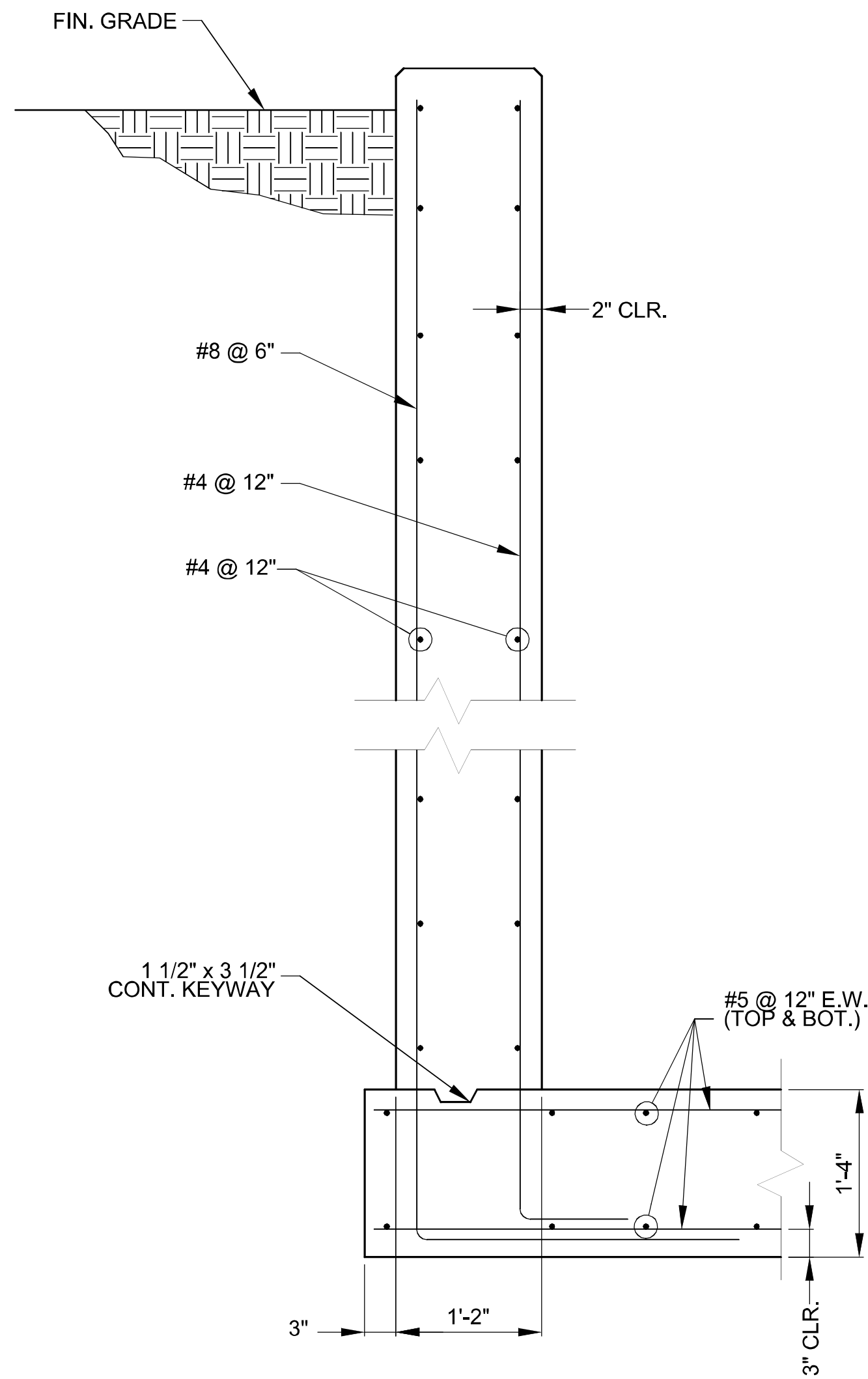

A VAULT WALL SECTION

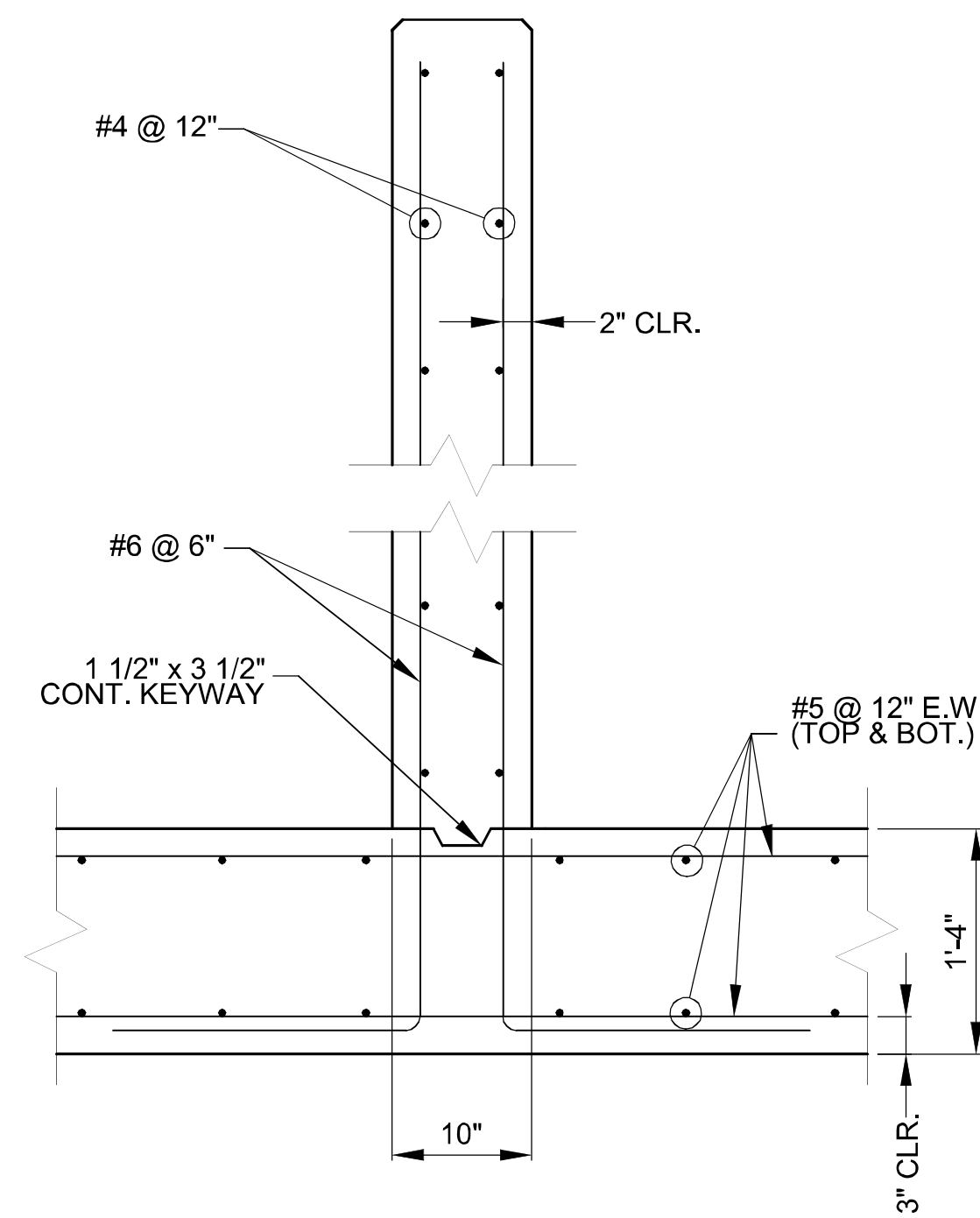

B VAULT WALL SECTION

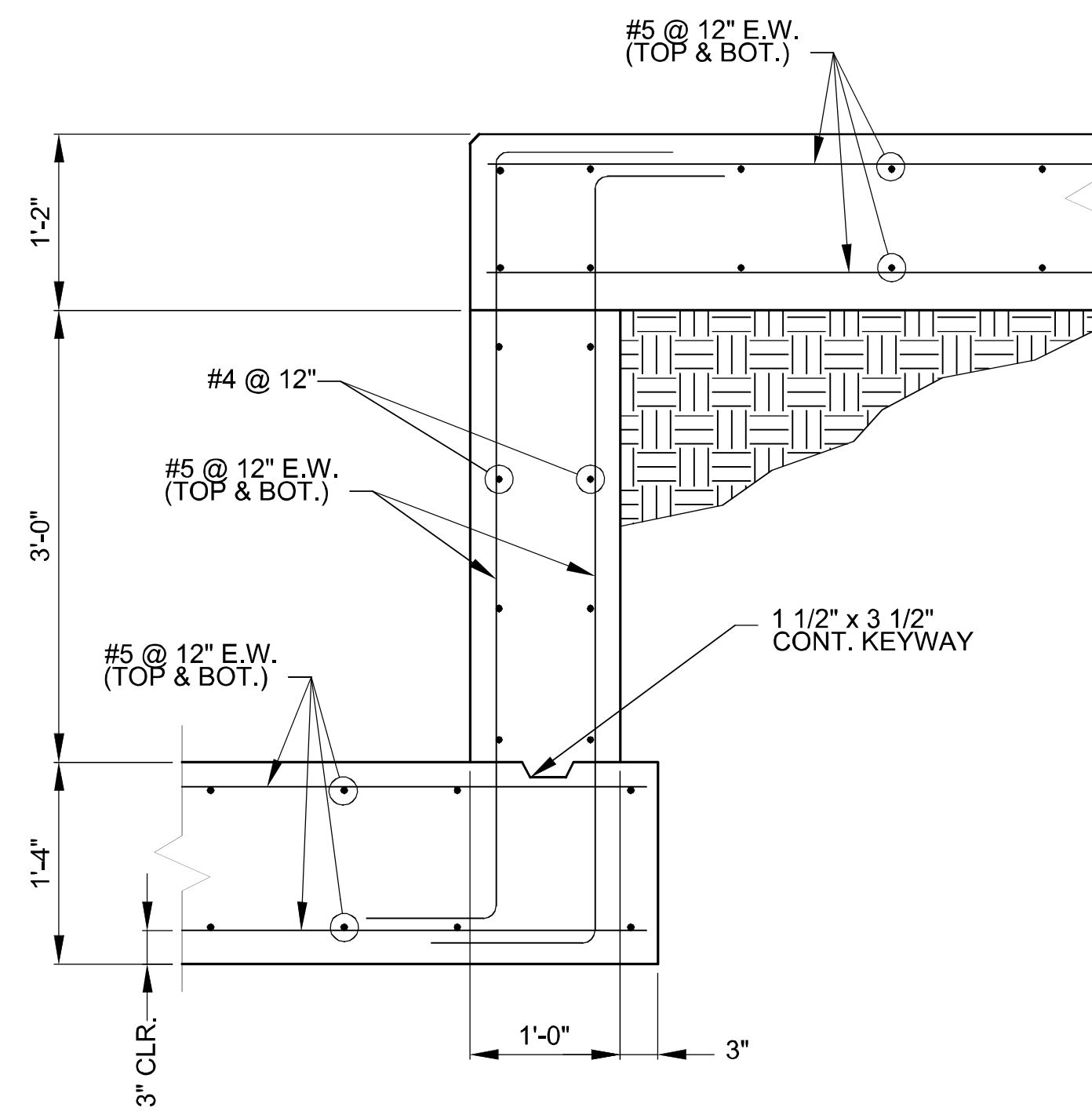

C VAULT WALL SECTION

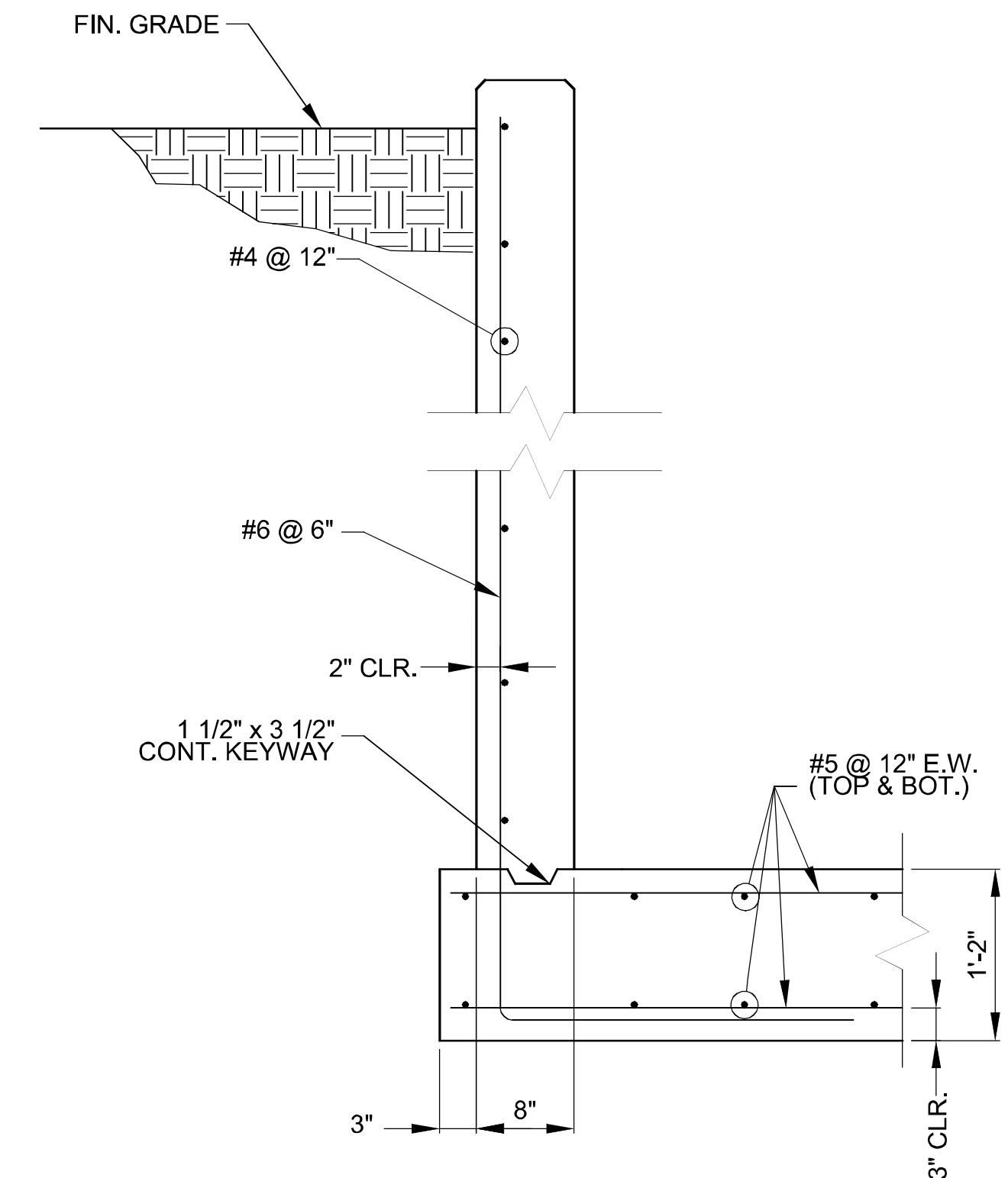

D VAULT WALL SECTION



San Engineering LLC
Civil and Structural Engineering
801 W. Mineral Ave.
Suite 200
Littleton, CO 80120
Phone: 303.953.9014

Enginuity
Engineering Solutions
10106 W. San Juan Way
Suite 215
Littleton, CO 80127
Phone: 303.872.9112
Fax: 303.872.9104

NO.	DESCRIPTION OF REVISIONS	DATE	BY

CALL UNCC
TWO WORKING DAYS
BEFORE YOU DIG
1-800-922-1887
UTILITY NOTICE CENTER OF
COLORADO

CITY AND COUNTY OF DENVER
DEPARTMENT OF PUBLIC WORKS
ENGINEERING DIVISION
CAPITAL PROJECTS MANAGEMENT
2000 W. 3RD AVE. DENVER, CO 80223
TEL.: (303) 446-3617 FAX: (303) 446-3647

HAMPDEN HEIGHTS STORM SEWER
IMPROVEMENTS - PHASE III
E. GIRARD AVE. OUTFALL
PCO CONTROL NO:
PILAR REVIEW NO:
VAULT WALL DETAILS (1)

DRAWN BY:	JM
DESIGNED BY:	JM
APPROVED BY:	JWS
DRAWING NAME:	Hampden Heights - Structural Details 10-17-14.dwg
DATE:	03/31/15
SHEET NO.:	17 of 32

PLOT DATE: March 31, 2015

Z:\PROJECTS\2014\106.002 (HAMPDEN HEIGHTS) \HAMPDEN HEIGHTS - STRUCTURAL DETAILS 10-17-14.DWG

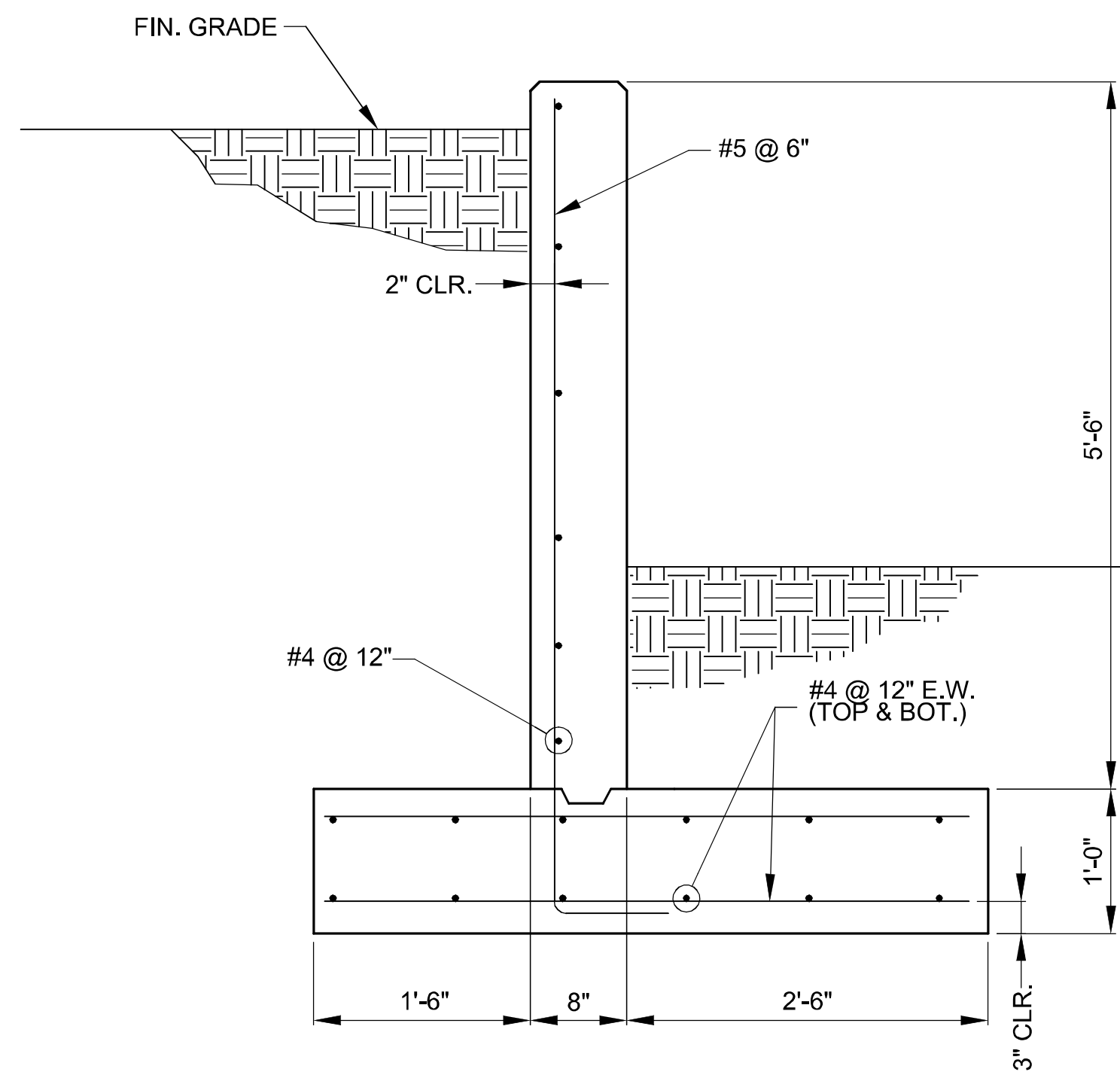

E VAULT WINGWALL SECTION

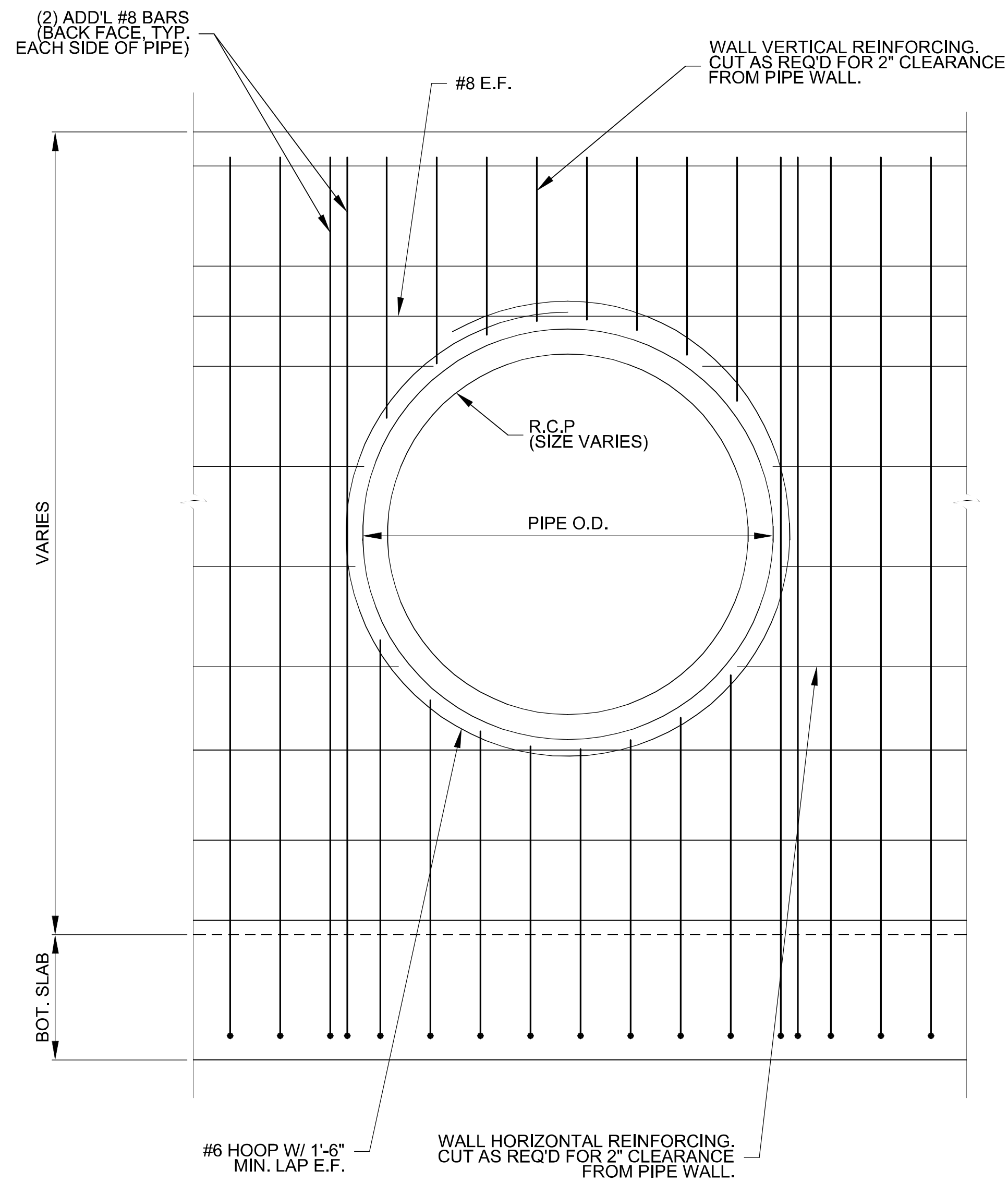

TYPICAL WALL REINFORCING ELEVATION AT PIPE OPENING

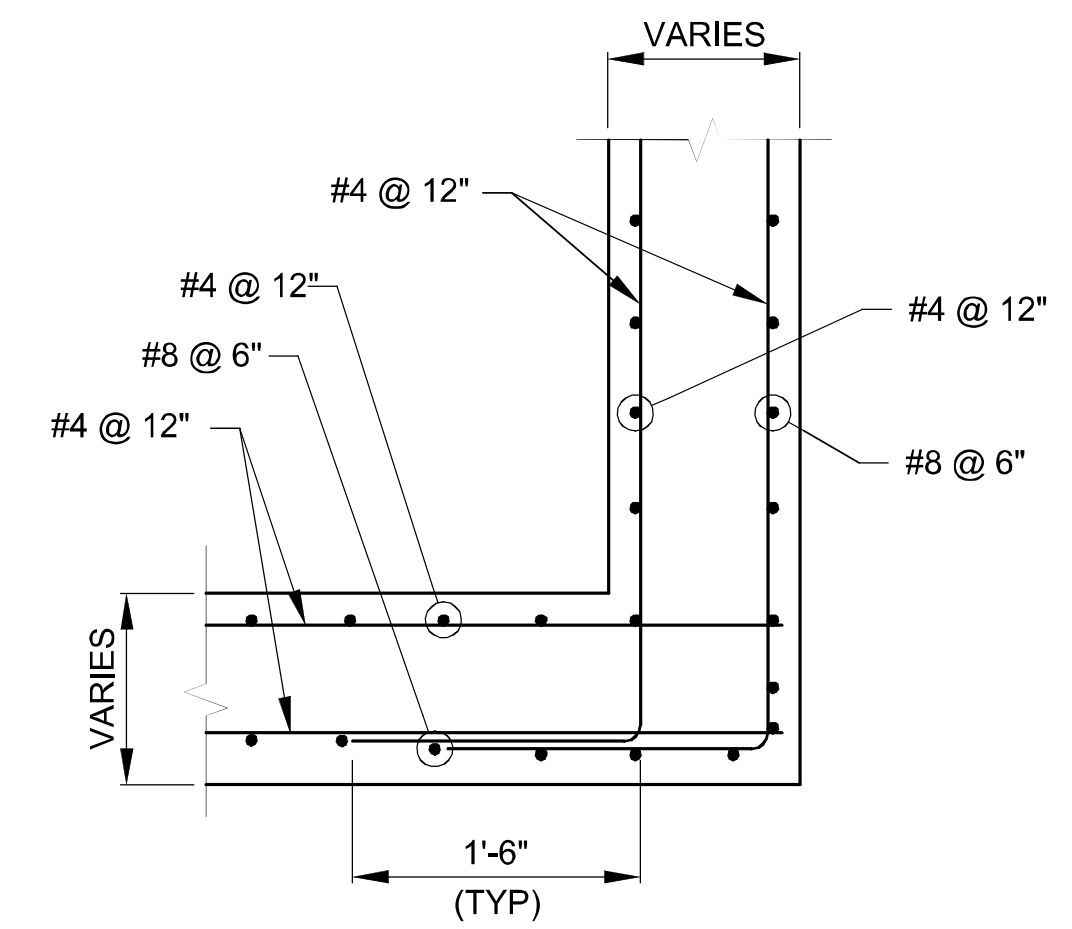

TYPICAL WALL CORNER DETAIL PLAN



San Engineering LLC
Civil and Structural Engineering
801 W. Mineral Ave.
Suite 200
Littleton, CO 80120
Phone: 303.953.9014

Enginuity
Engineering Solutions
10106 W. San Juan Way
Suite 215
Littleton, CO 80127
Phone: 303.872.9112
Fax: 303.872.9104

NO.	DESCRIPTION OF REVISIONS	DATE	BY

CALL UNCC
TWO WORKING DAYS
BEFORE YOU DIG
1-800-922-1887
UTILITY SERVICE CENTER OF
COLORADO



CITY AND COUNTY OF DENVER
DEPARTMENT OF PUBLIC WORKS
ENGINEERING DIVISION
CAPITAL PROJECTS MANAGEMENT
2000 W. 3RD AVE. DENVER, CO 80223
TEL.: (303) 446-3617 FAX: (303) 446-3647

HAMPDEN HEIGHTS STORM SEWER
IMPROVEMENTS - PHASE III
E. GIRARD AVE. OUTFALL
PCO CONTROL NO:
PILAR REVIEW NO:
VAULT WALL DETAILS (2)

DRAWN BY:	JM
DESIGNED BY:	JM
APPROVED BY:	JWS
DRAWING NAME:	Hampden Heights - Structural Details 10-17-14.dwg
DATE:	03/31/15
SHEET NO.:	18 of 32

Z:\PROJECTS\2014\106\002 (HAMPDEN HEIGHTS)\HAMPDEN HEIGHTS - STRUCTURAL DETAILS 10-17-14.DWG PLOT DATE: March 31, 2015

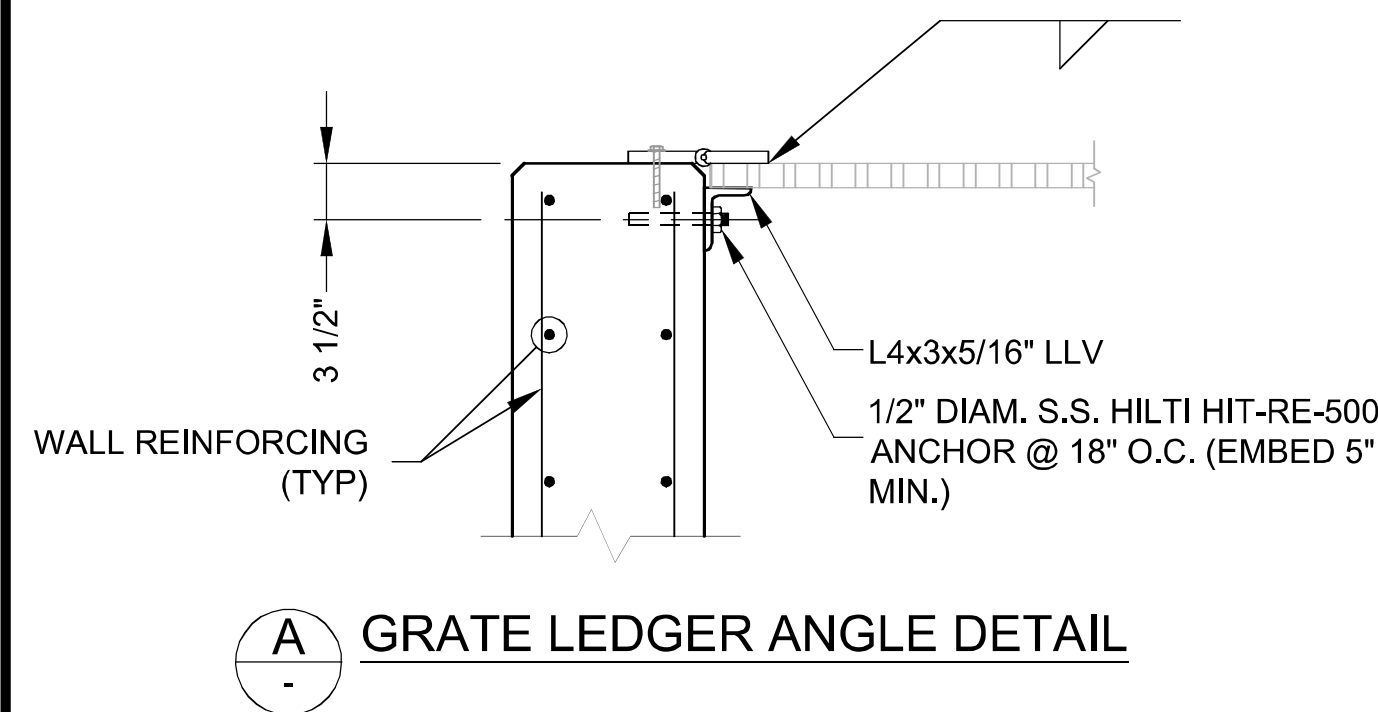

A GRATE LEDGER ANGLE DETAIL

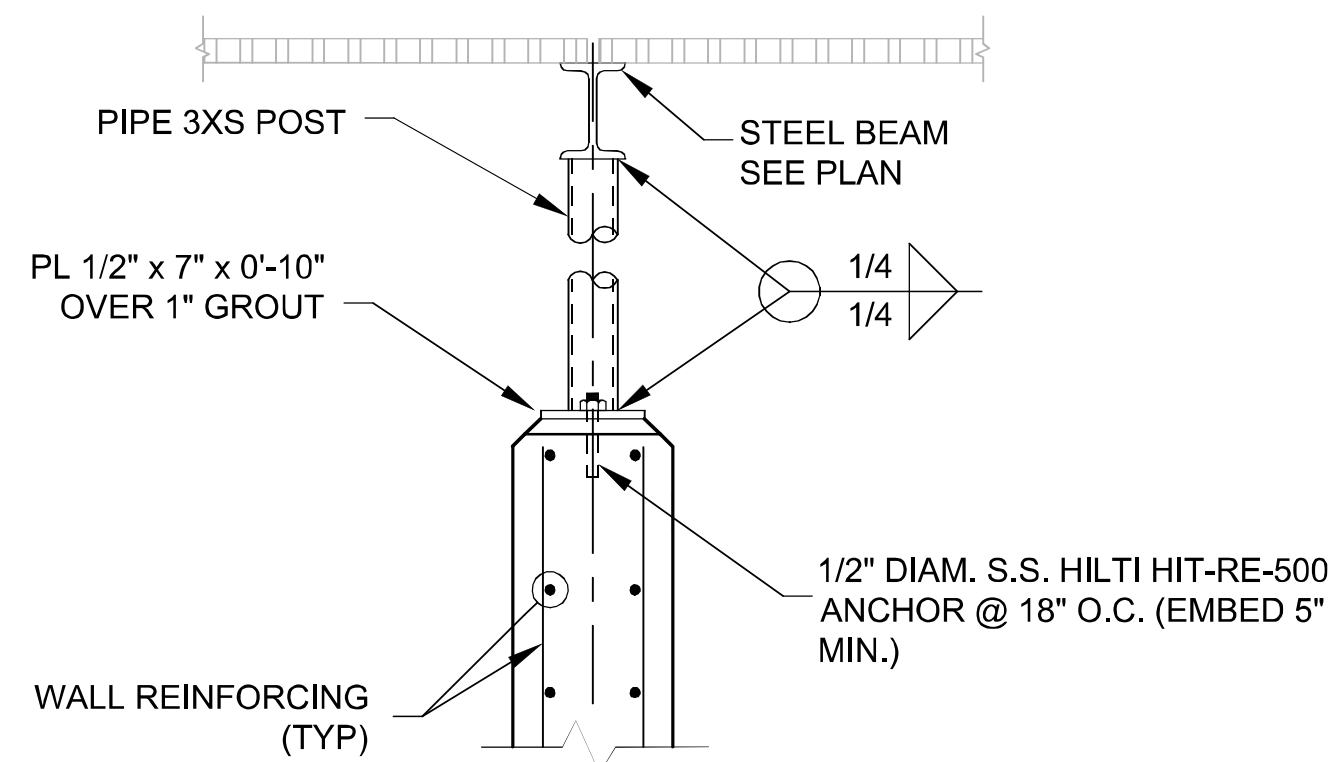

B GRATE SUPPORT POST DETAIL

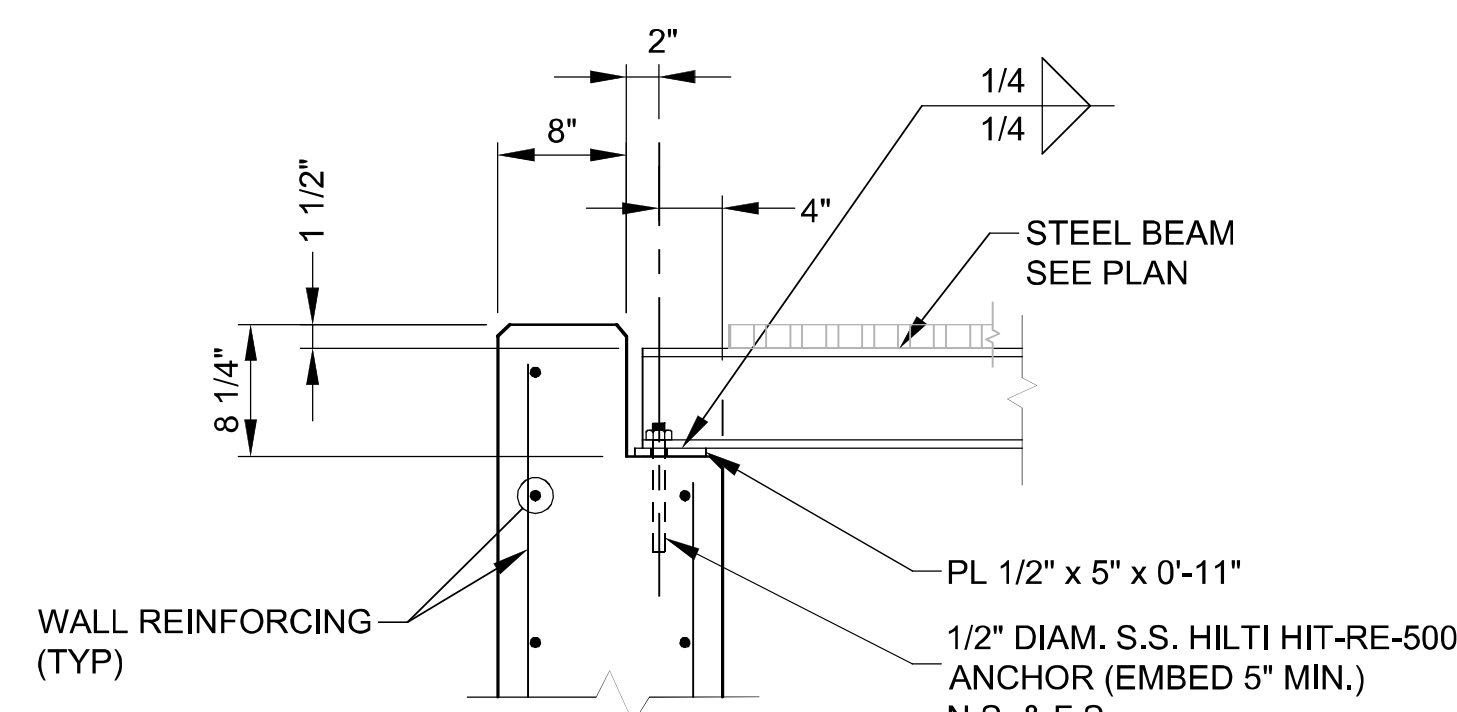

C GRATE SUPPORT BEAM POCKET

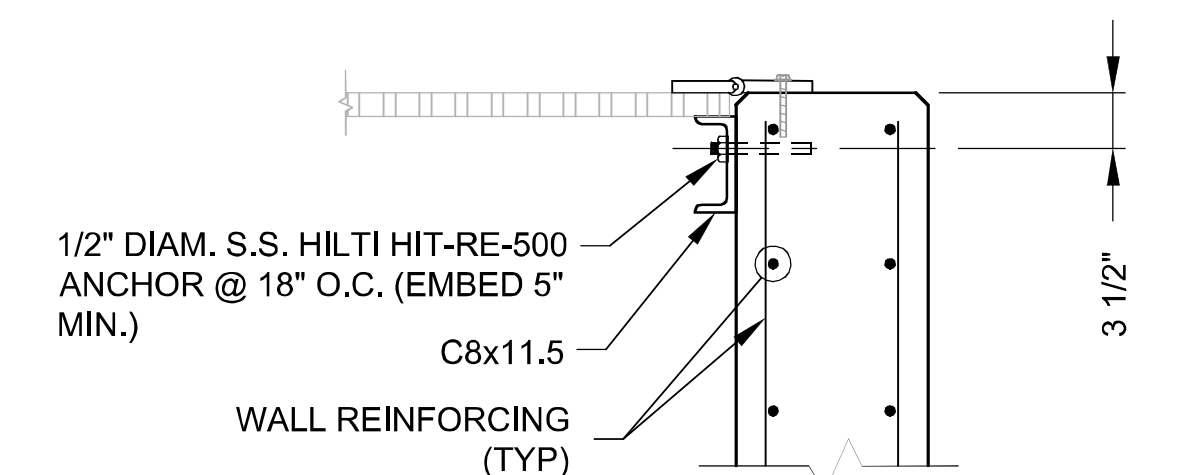

D GRATE LEDGER CHANNEL DETAIL

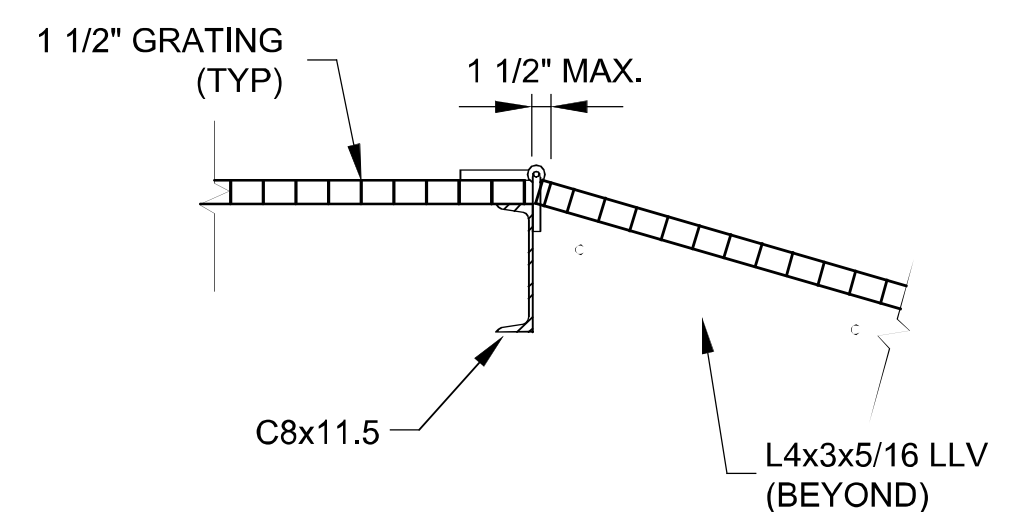

E FRAMING DETAIL AT OPENING

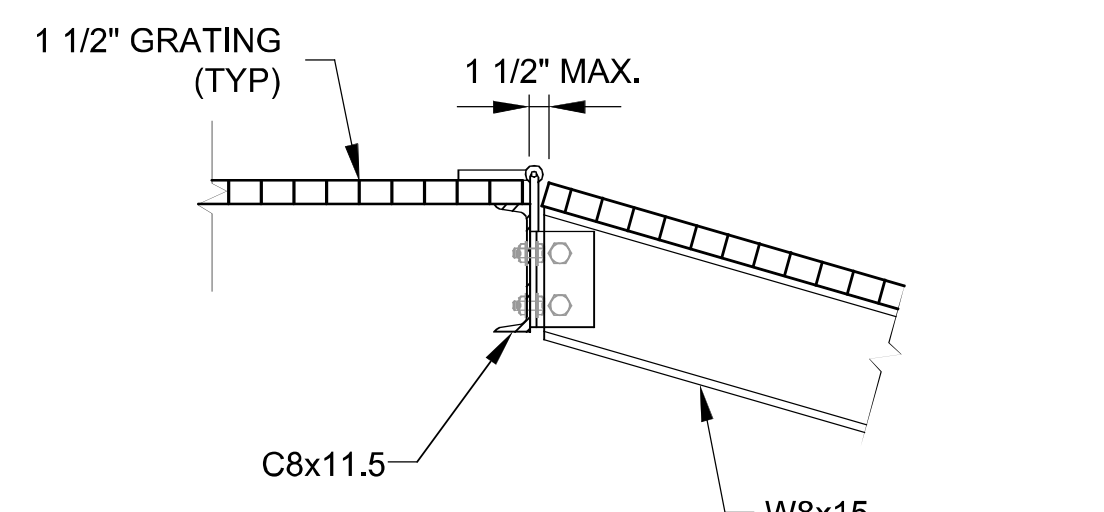

F FRAMING DETAIL AT BEAM CONN.

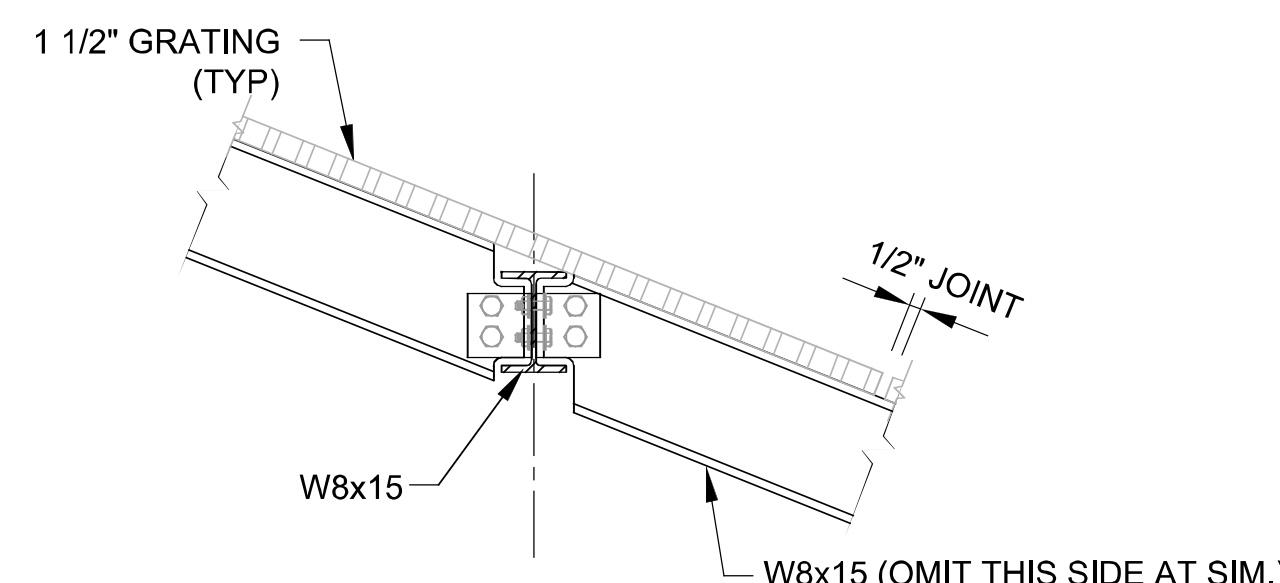

G FRAMING DETAIL AT BEAM CONN.

STRUCTURAL FRAMING NOTES

1. SHOP DRAWINGS FOR ALL STRUCTURAL STEEL FRAMING, GRATING, AND ATTACHMENTS SHALL BE SUBMITTED FOR APPROVAL.
2. THE FABRICATOR MAY PROPOSE AN ALTERNATE SYSTEM OF HINGING AND ATTACHMENT OF GRATING ASSEMBLIES. ANY ASSOCIATED DETAILS SHALL BE INCLUDED ON THE SHOP DRAWINGS.

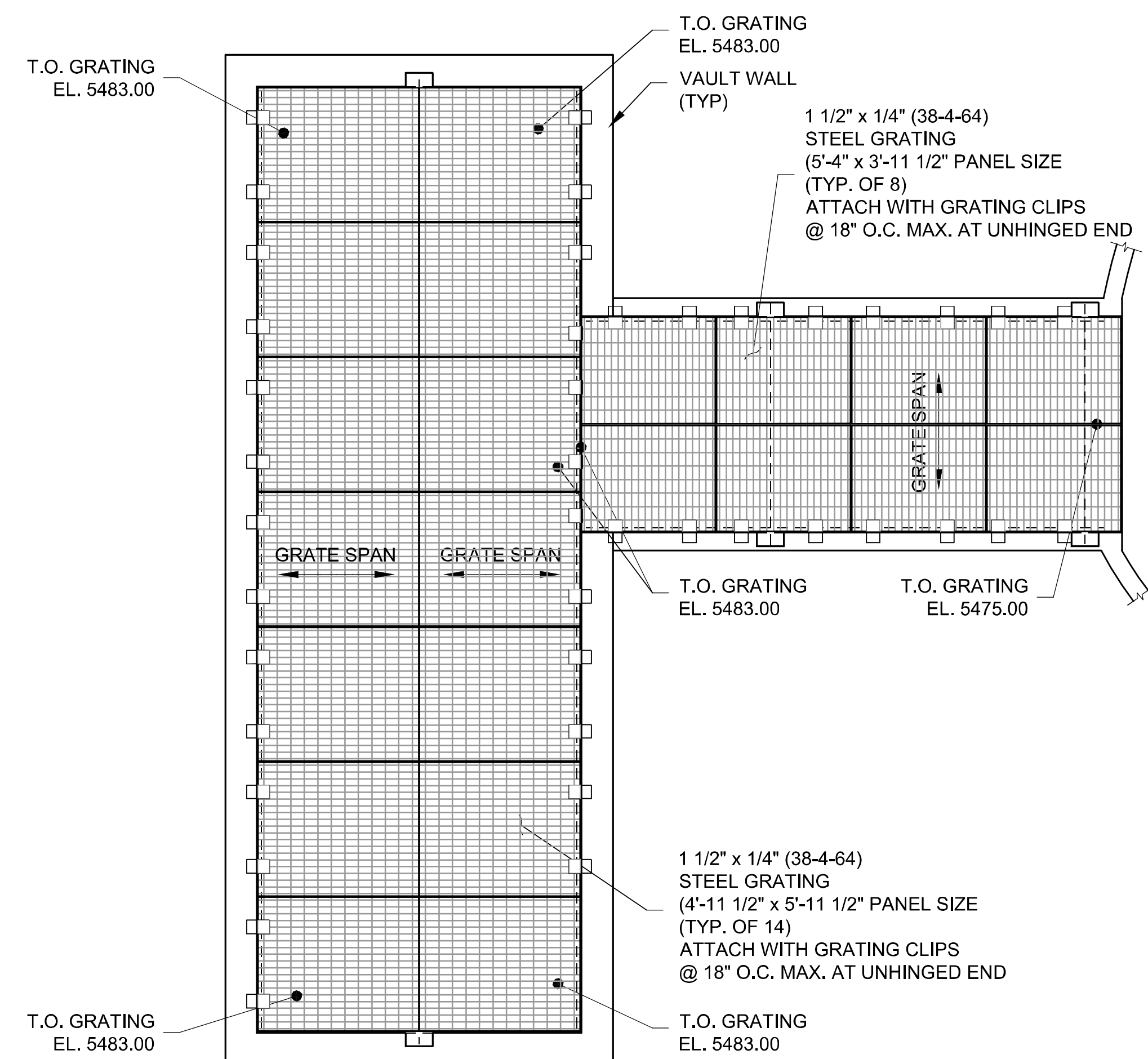

GRATING LAYOUT PLAN

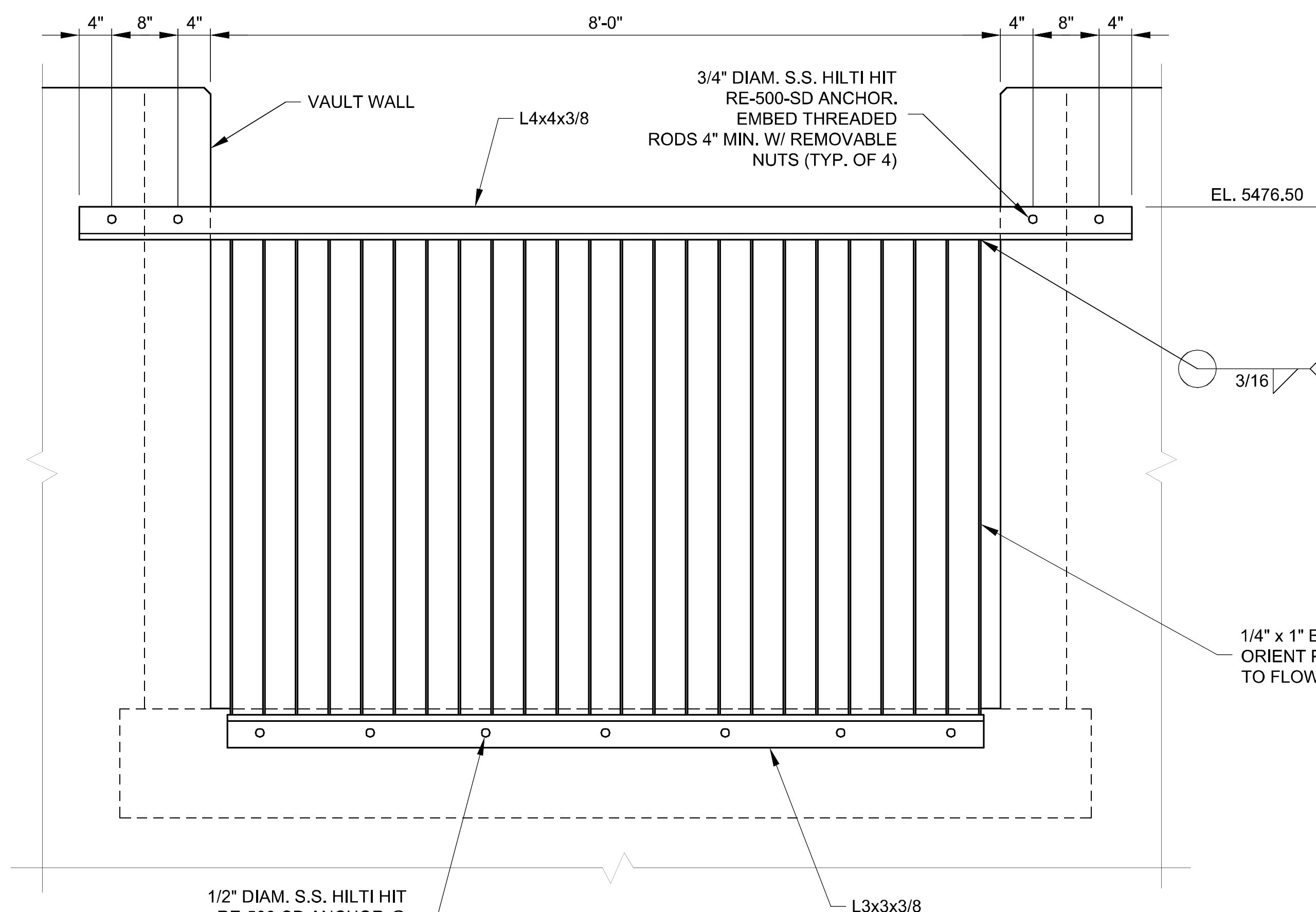

REMOVABLE GRATE ELEVATION



San Engineering LLC
Civil and Structural Engineering
801 W. Mineral Ave.
Suite 200
Littleton, CO 80120
Phone: 303.953.9014

Enginuity
Engineering Solutions
10106 W. San Juan Way
Suite 215
Littleton, CO 80127
Phone: 303.872.9112
Fax: 303.872.9104

NO.	DESCRIPTION OF REVISIONS	DATE	BY

CALL UNCC
TWO WORKING DAYS
BEFORE YOU DIG
1-800-922-1887
UTILITY SERVICES CENTER OF
COLORADO

CITY AND COUNTY OF DENVER
DEPARTMENT OF PUBLIC WORKS
ENGINEERING DIVISION
CAPITAL PROJECTS MANAGEMENT
2000 W. 3RD AVE. DENVER, CO 80223
TEL.: (303) 446-3617 FAX: (303) 446-3647

**HAMPDEN HEIGHTS STORM SEWER
IMPROVEMENTS - PHASE III
E. GIRARD AVE. OUTFALL**
PCO CONTROL NO:
PILAR REVIEW NO:
VAULT FRAMING DETAILS

DRAWN BY:	JMM / RJK
DESIGNED BY:	JM
APPROVED BY:	JM
DRAWING NAME:	Hampden Heights - Structural Details 10-17-14.dwg
DATE:	03/31/15
SHEET NO.:	19 of 32

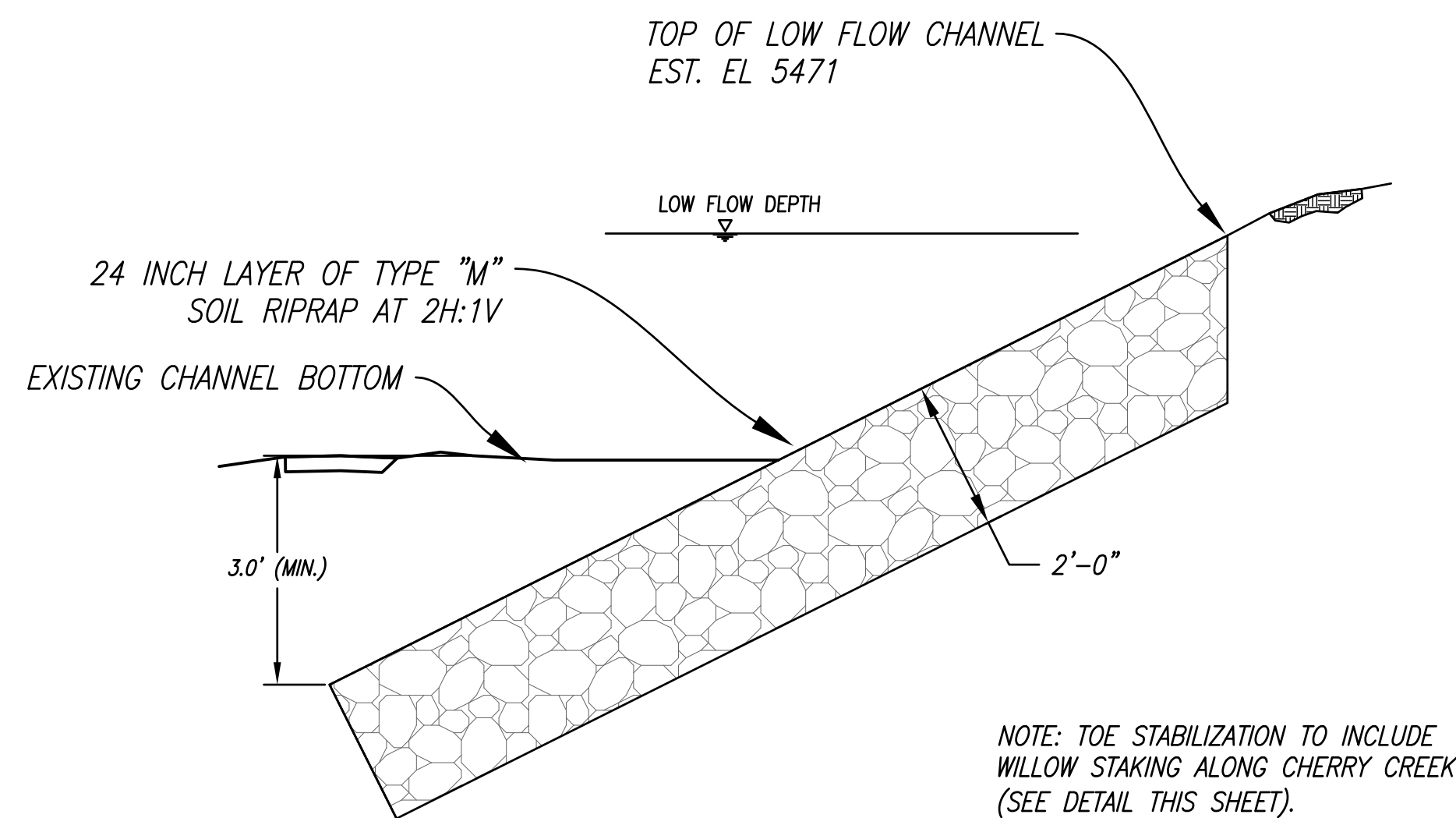

1 CHERRY CREEK TOE STABILIZATION NTS

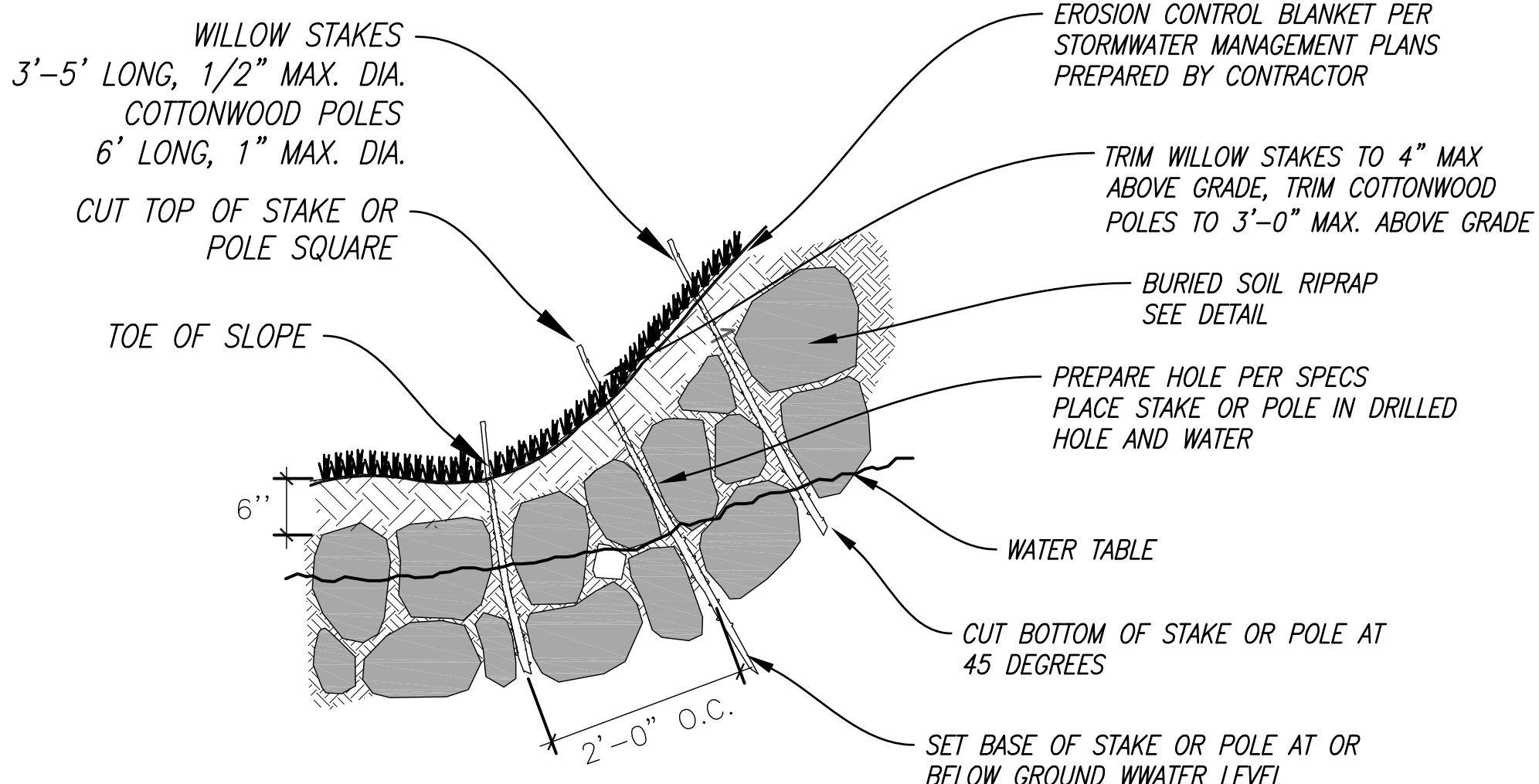

2 WILLOW STAKE PLANTING NTS

1. REFER TO SPECIFICATION BEFORE PLANTING.
2. CONDITIONS VARY, WILLOW STAKES/COTTONWOOD POLES MAY OCCUR IN AREAS OF EMBANKMENT, SOIL RIPRAP, AND EROSION MAT—SEE PLANS FOR SPECIFIC CONDITIONS.
3. DIG TEST HOLE IN EACH AREA DESIGNATED FOR WILLOW STAKES OR COTTONWOOD POLES, TO DETERMINE DEPTH OF WATER TABLE. PLANT WILLOW STAKES AND COTTONWOOD POLES SO THAT BOTTOM 6" OF STAKE/POLE (MIN.) IS BELOW WATER TABLE DEPTH.
4. SOURCE FOR WILLOW STAKES AND COTTONWOOD POLES TO BE APPROVED BY OWNER'S REPRESENTATIVE.
5. WHEN HARVESTING WILLOW STAKES AND COTTONWOOD POLES, CUT BOTTOM OF STAKE OR POLE AT 45 DEGREES AND CUT TOP OF STAKE OR POLE SQUARE. PLANT ANGLED END INTO THE GROUND, PLANT SHOULD BE PLACED IN THE SAME ORIENTATION AS IT WAS HARVESTED (PLANT RIGHT SIDE UP).
6. WILLOW STAKES AND COTTONWOOD POLES SHOULD ONLY BE COLLECTED WHEN THEY ARE DORMANT, APPROXIMATELY FROM NOVEMBER TO MARCH. IT IS THE CONTRACTOR'S RESPONSIBILITY TO COLLECT THE PROPER NUMBER OF STAKES OR POLES AND STORE THEM IN AN APPROVED MANNER (SEE SPECIFICATIONS).
7. TWO TO FIVE BUD SCARS SHOULD BE ABOVE THE GROUND. APPROXIMATELY 80% OF THE PLANT SHOULD BE BELOW GRADE. ALL STAKES OR POLES SHOULD BE SOAKED FOR A MINIMUM OF 24 HOURS BEFORE PLANTING.

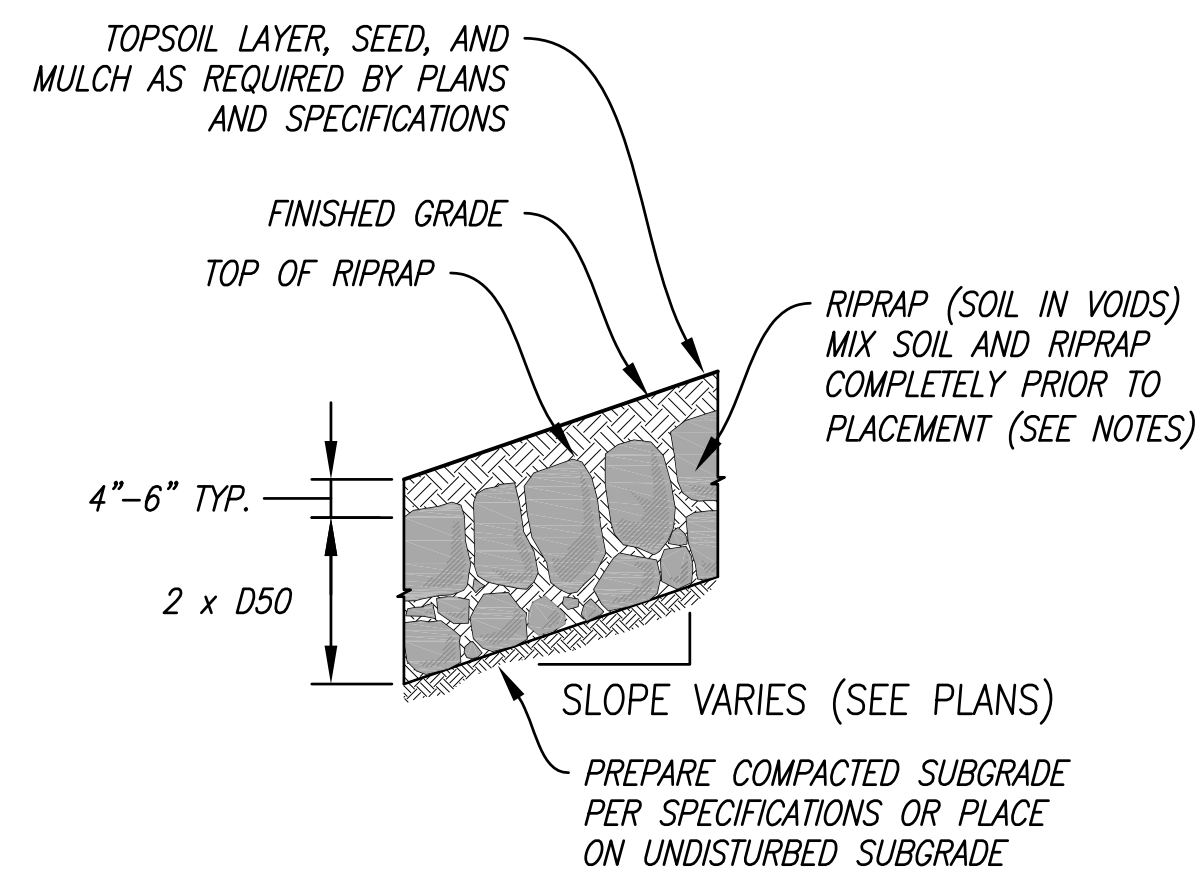

3 TYPICAL SECTION SOIL RIPRAP WITH MULCH NTS

- NOTES:
1. SOIL RIPRAP DETAILS ARE APPLICABLE TO SLOPED AREAS. REFER TO THE SITE PLAN ACTUAL LOCATION AND LIMITS.
 2. MIX UNIFORMLY 65% RIPRAP BY VOLUME WITH 35% OF APPROVED SOIL BY VOLUME PRIOR TO PLACEMENT.
 3. PLACE STONE-SOIL MIX TO RESULT IN SECURELY INTERLOCKED ROCK AT THE DESIGN THICKNESS AND GRADE. COMPACT AND LEVEL TO ELIMINATE ALL VOIDS AND ROCKS PROJECTING ABOVE DESIGN RIPRAP TOP GRADE.
 4. CRIMP OR TACKIFY MULCH OR USE APPROVED HYDROMULCH AS CALLED FOR IN THE PLANS AND SPECIFICATIONS.
 5. BLANKET SLOPES IN EXCESS OF 4:1.

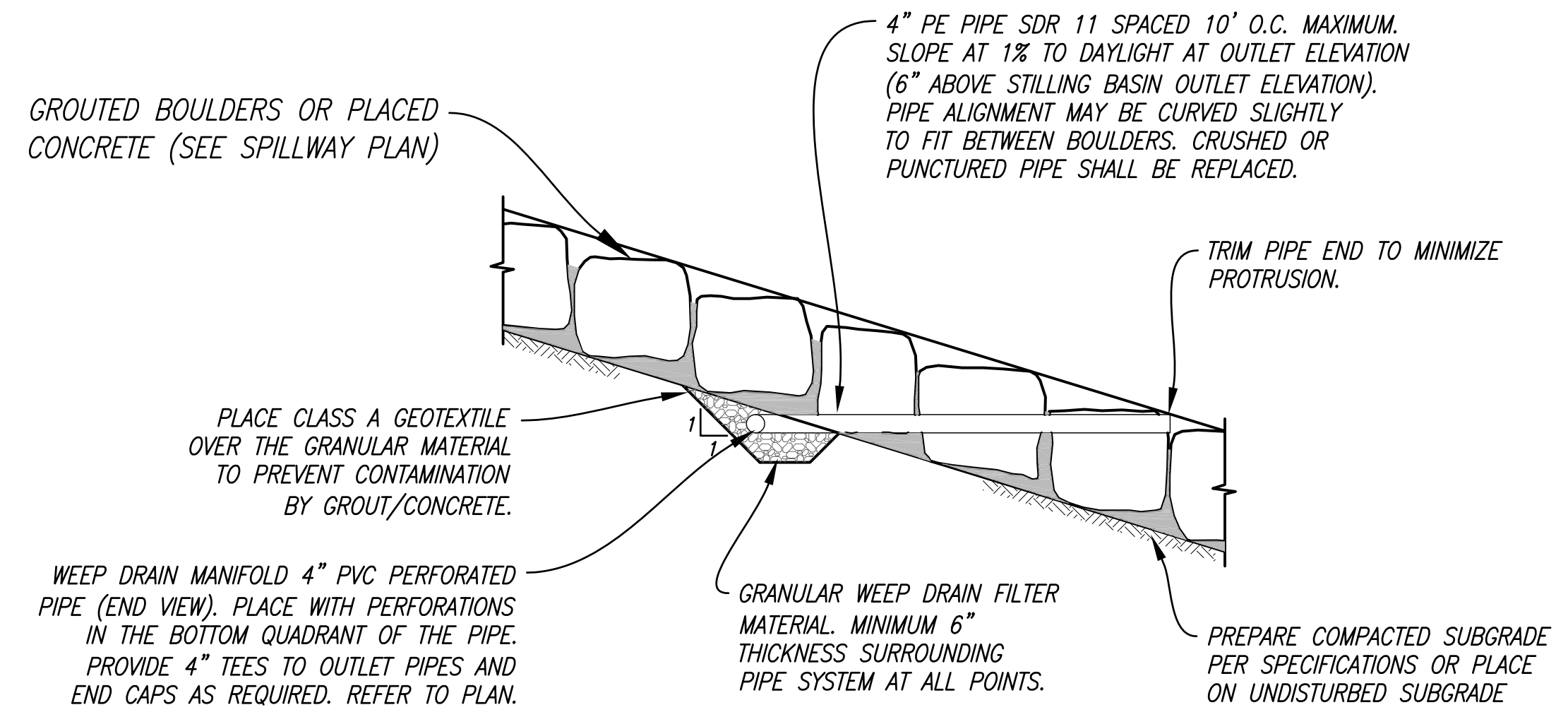

4 TYPICAL WEEP A DRAIN SYSTEM NTS

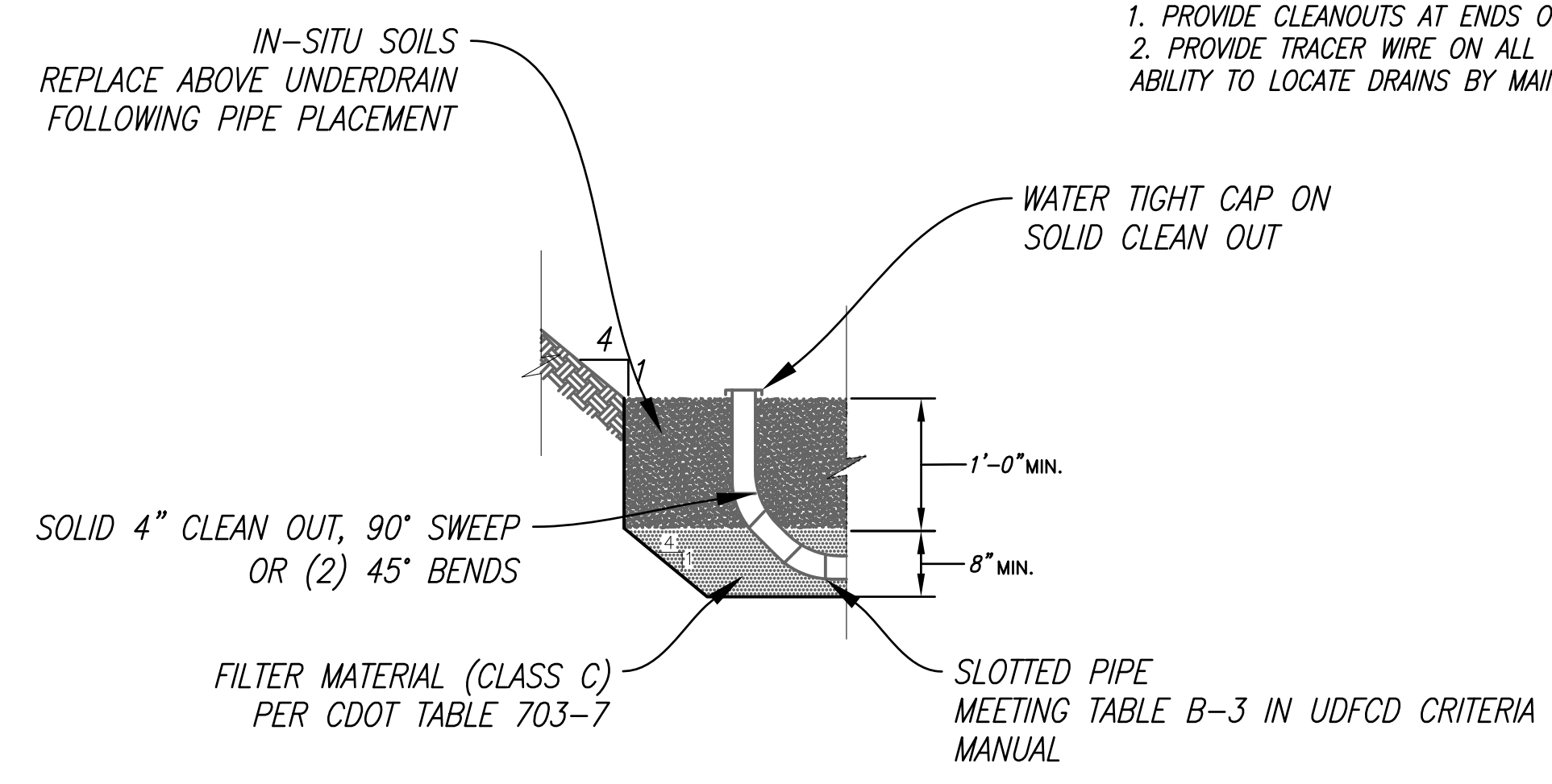

5 BIORETENTION POND - UNDERDRAIN SECTION NTS

- NOTES:
1. PROVIDE CLEANOUTS AT ENDS OF ALL LINES.
 2. PROVIDE TRACER WIRE ON ALL UNDERDRAIN PIPES FOR FUTURE ABILITY TO LOCATE DRAINS BY MAINTENANCE CREWS.

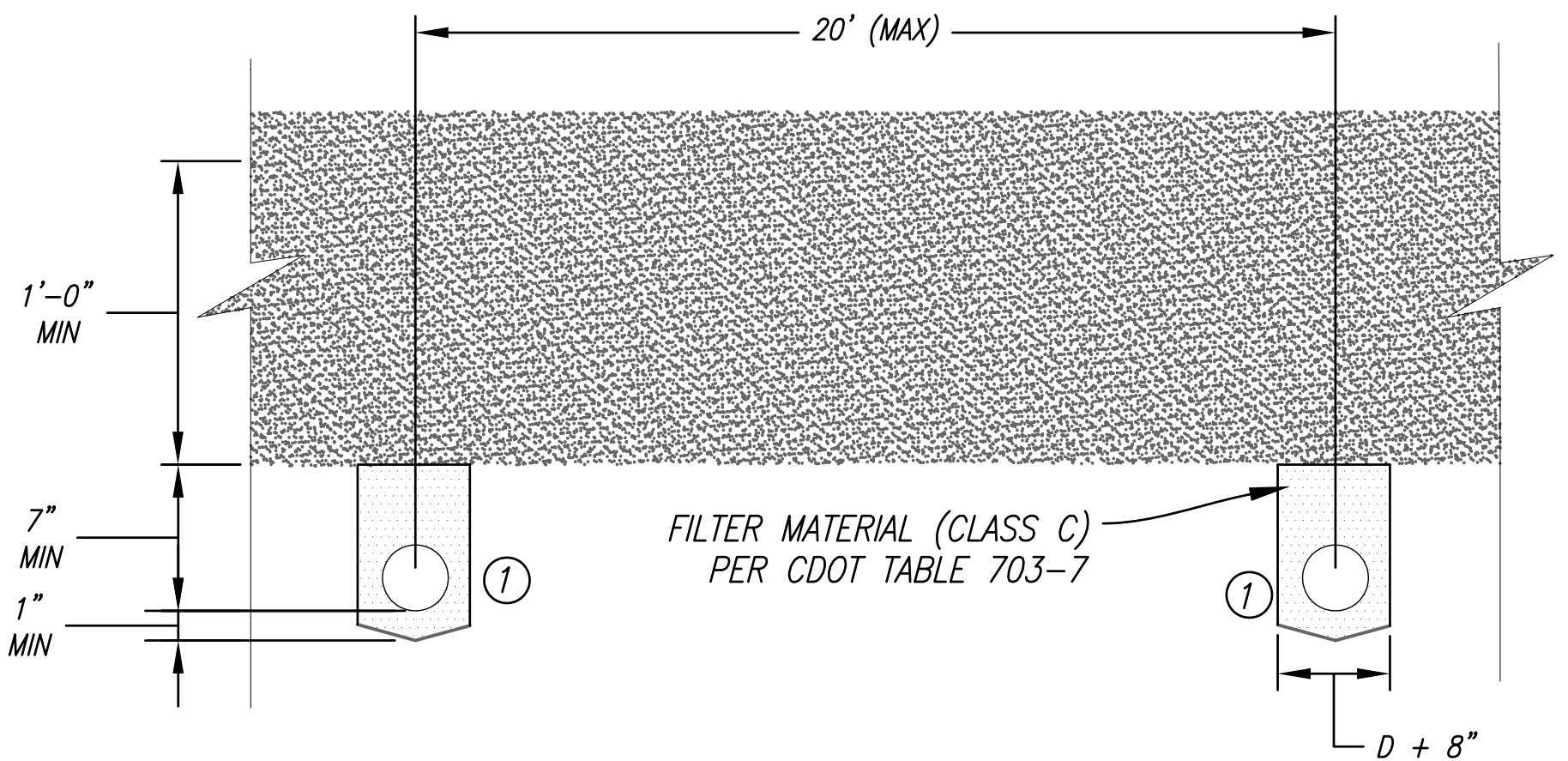

6 BIORETENTION POND - DRAIN AND SUBGRADE DETAIL NTS

① UNDERDRAIN TRENCH WIDTH TO BE MINIMUM OF DIAMETER + 8" (4" CLR. EACH SIDE OF PIPE)

C:\ENGINEERING\PROJECTS\DENVER\13-006 HAMPDEN HEIGHTS PHASE II OUTFALL/CADD\PLANS\DETAILS\ROCKDETAILS.DWG PLOT DATE: March 30, 2015

NO.	DESCRIPTION OF REVISIONS	DATE	BY

CALL UNCC
TWO WORKING DAYS
BEFORE YOU DIG
1-800-922-1987
UTILITY WARNING CENTER

CITY AND COUNTY OF DENVER
DEPARTMENT OF PUBLIC WORKS
ENGINEERING DIVISION
CAPITAL PROJECTS MANAGEMENT
2000 W. 3RD AVE. DENVER, CO 80223
TEL.: (303) 446-3617 FAX: (303) 446-3647

HAMPDEN HEIGHTS STORM SEWER
IMPROVEMENTS - PHASE III
E. GIRARD AVE. OUTFALL
PCO CONTROL NO: PWC2009-5013
PILAR REVIEW NO: 2011-0426-01
MISCELLANEOUS DETAILS

DRAWN BY:	JWS
DESIGNED BY:	JWS
APPROVED BY:	DJJ
DRAWING NAME:	RockDetails.dwg
DATE:	03/18/15
SHEET NO.:	20 of 32

10106 W. San Juan Way
Suite 215
Littleton, CO 80127
Phone: 303.872.9112
Fax: 303.872.9104

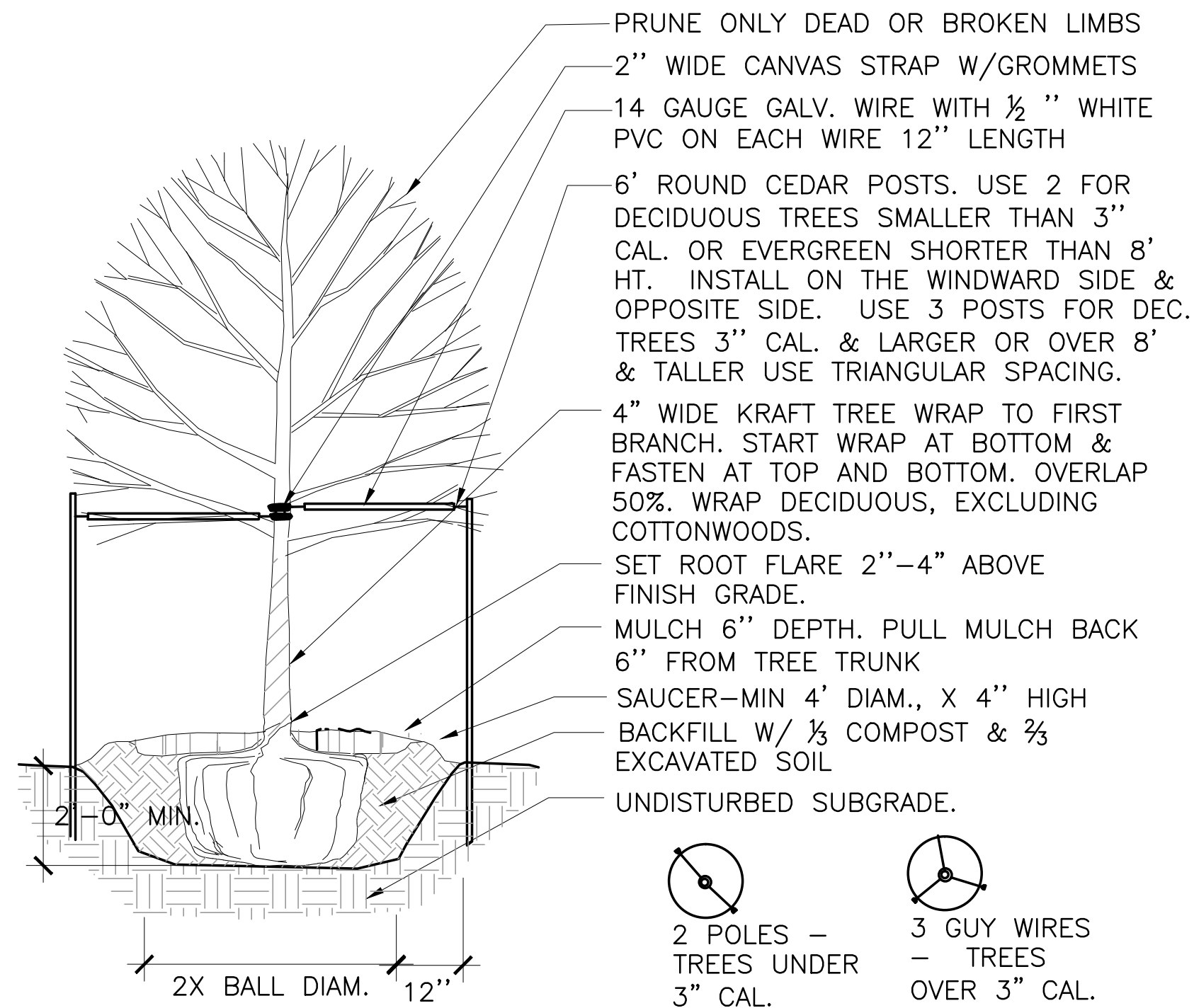

- NOTES:**
 1. SEE SPECIFICATIONS FOR ADDITIONAL PLANTING REQUIREMENTS.
 2. CUT AWAY & REMOVE ALL WIRE, OTHER RESTRAINING MATERIAL, AND TOP 3/4 OF BURLAP AFTER PLANT IS SET IN PLANTING HOLE.
 3. SCARIFY PIT WALLS.
 4. PLUMB AND ORIENT PLANTS FOR BEST APPEARANCE.

01 DECIDUOUS TREE PLANTING
 NTS

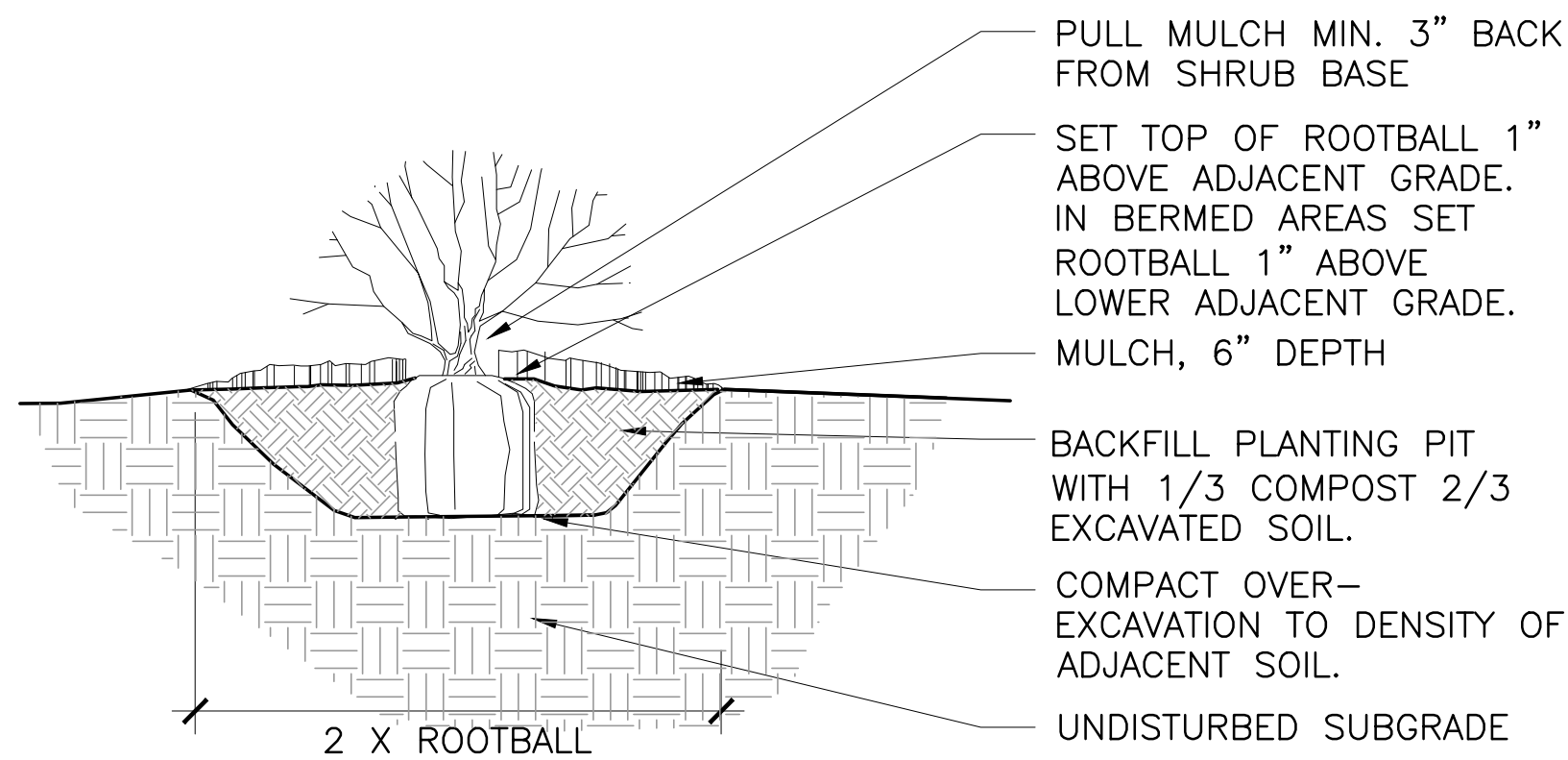

- NOTES:**
 1. SEE SPECS FOR ADDITIONAL PLANTING REQUIREMENTS.
 2. PLUMB AND ORIENT PLANTS FOR BEST APPEARANCE.
 3. CAREFULLY REMOVE CONTAINER AND SCORE ROOT BALL.

02 SHRUB PLANTING
 NTS

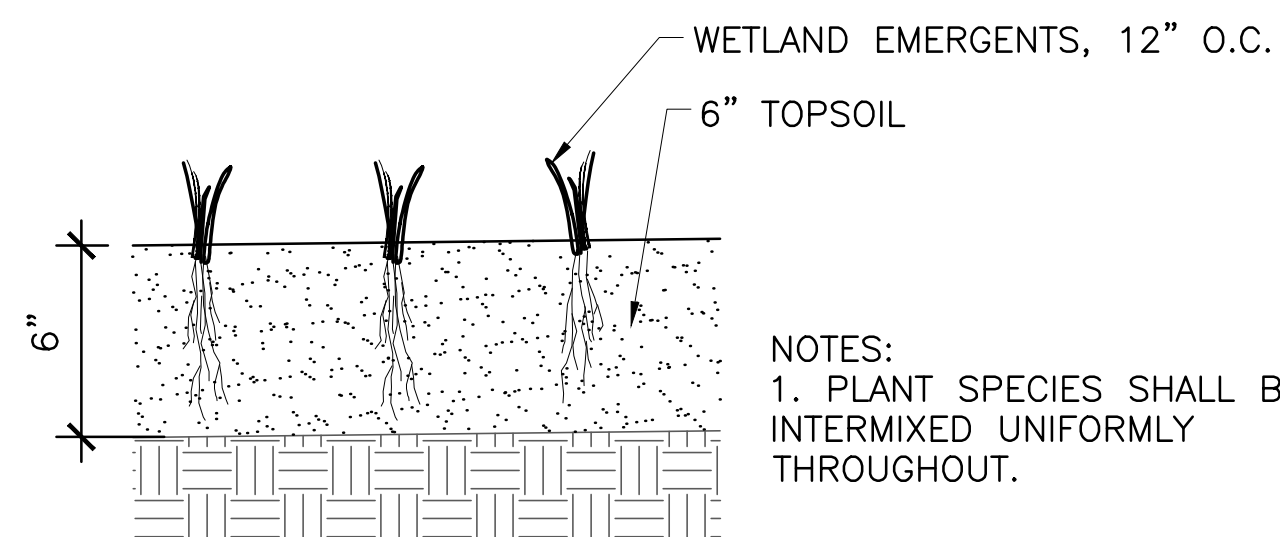

03 WETLAND PLUGS

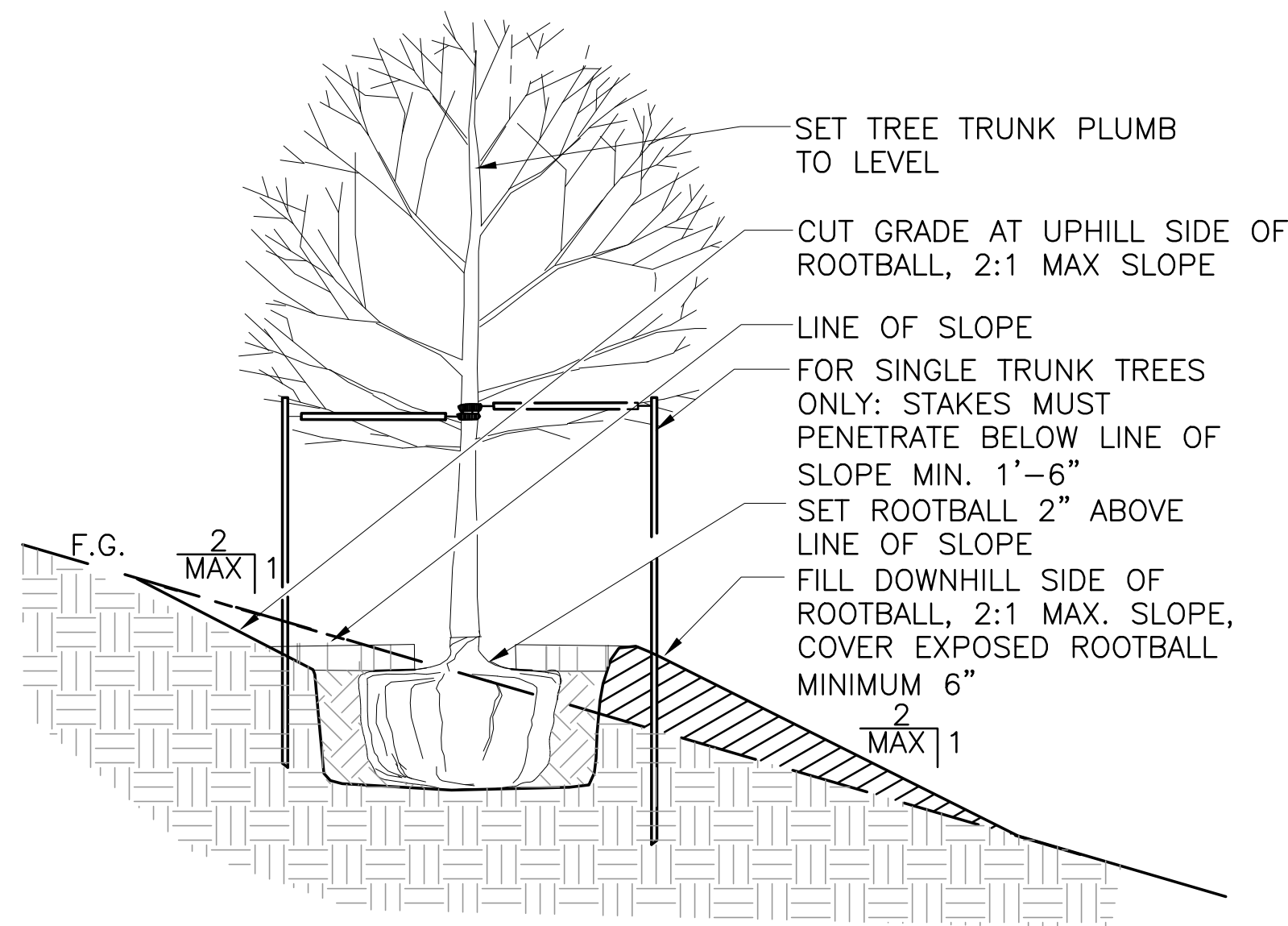

TREE PLANTING ON SLOPE

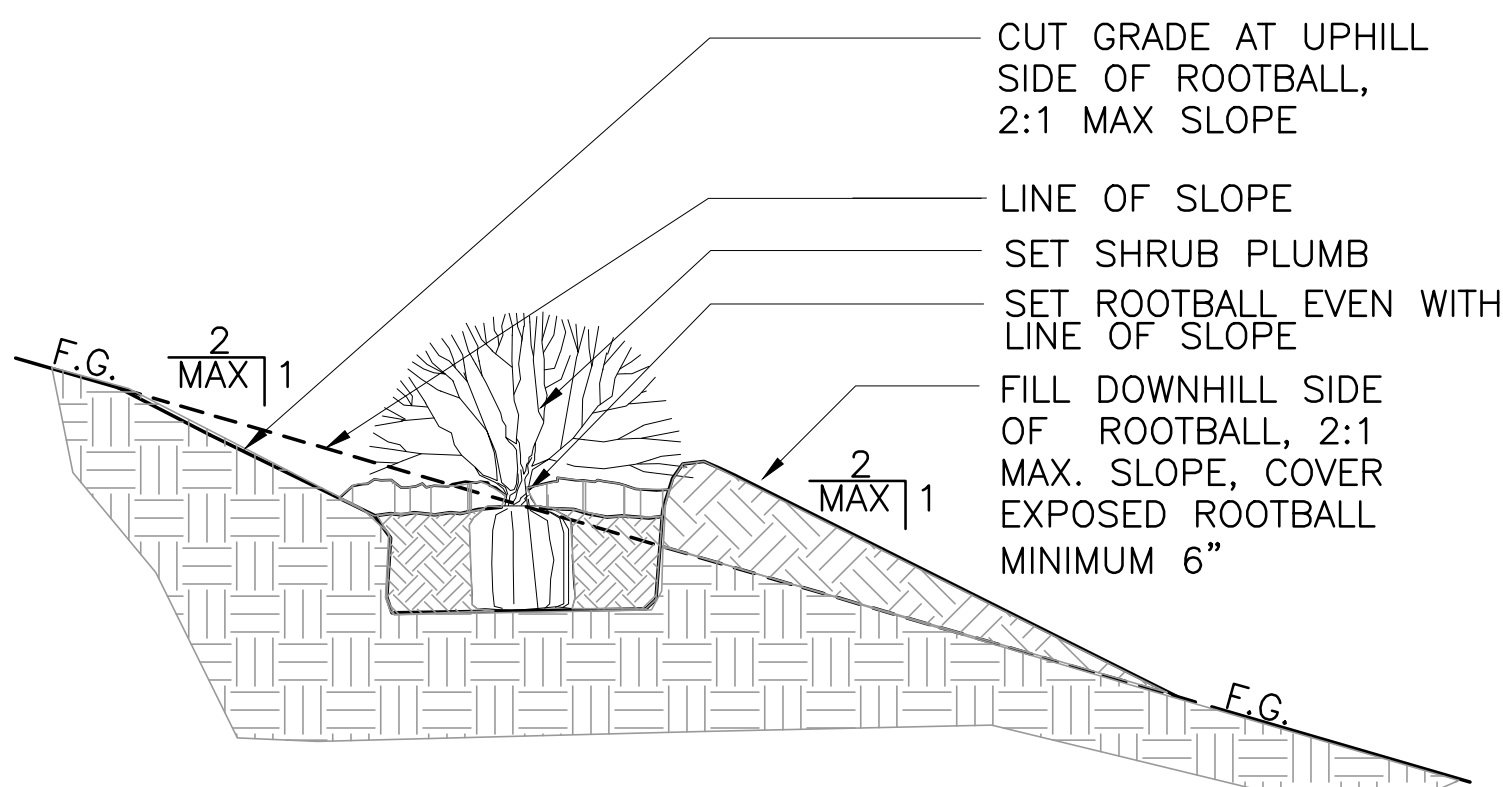

**THIS INSTALLATION SHALL APPLY TO ALL SHRUB TYPES AND SIZES PLANTED ON SLOPES GREATER THAN 5:1 AND LESS THAN 3:1.

SHRUB PLANTING ON SLOPE

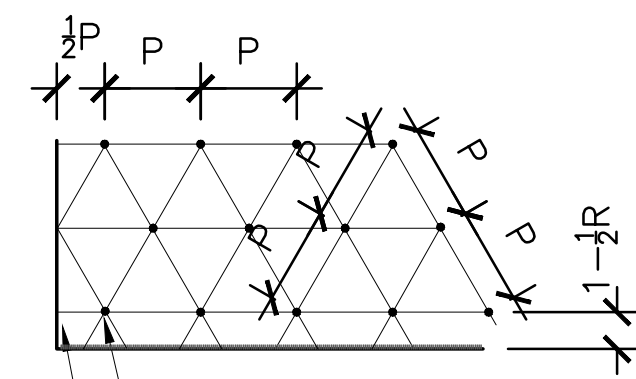

P TRIANGULAR	R ROW	AREA PER PLANT, SQ. FT.
6"	5 1/4"	0.22
8"	7"	0.385
10"	8 3/4"	0.60
12"	10 3/8"	0.87
18"	1'-3 5/8"	1.95
24"	1'-8 3/4"	3.46
3'	2'-7"	7.80
4'	3'-6"	13.80

FOR TRIANGULAR SPACING OF SHRUBS, ORNAMENTAL GRASSES, ANNUALS, PERENNIALS AND GROUNDCOVERS, SEE PLANT LIST FOR SPACING DISTANCE.

EDGE OF PAVING, WALL, PLANTER BED, OR LANDSCAPE BORDER, RE: PLAN

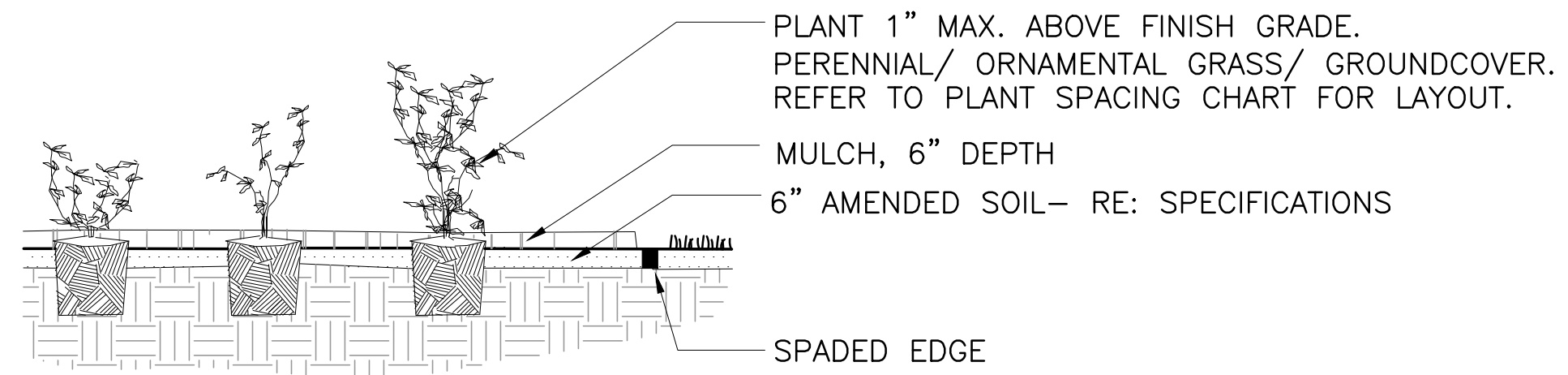

- NOTES:**
 1. SEE SPECS FOR ADDITIONAL PLANTING REQUIREMENTS.
 2. PLUMB AND ORIENT PLANTS FOR BEST APPEARANCE.
 3. CAREFULLY REMOVE CONTAINER AND SCORE ROOT BALL.

04 PERENNIAL / ORNAMENTAL GRASSES PLANTING
 NTS

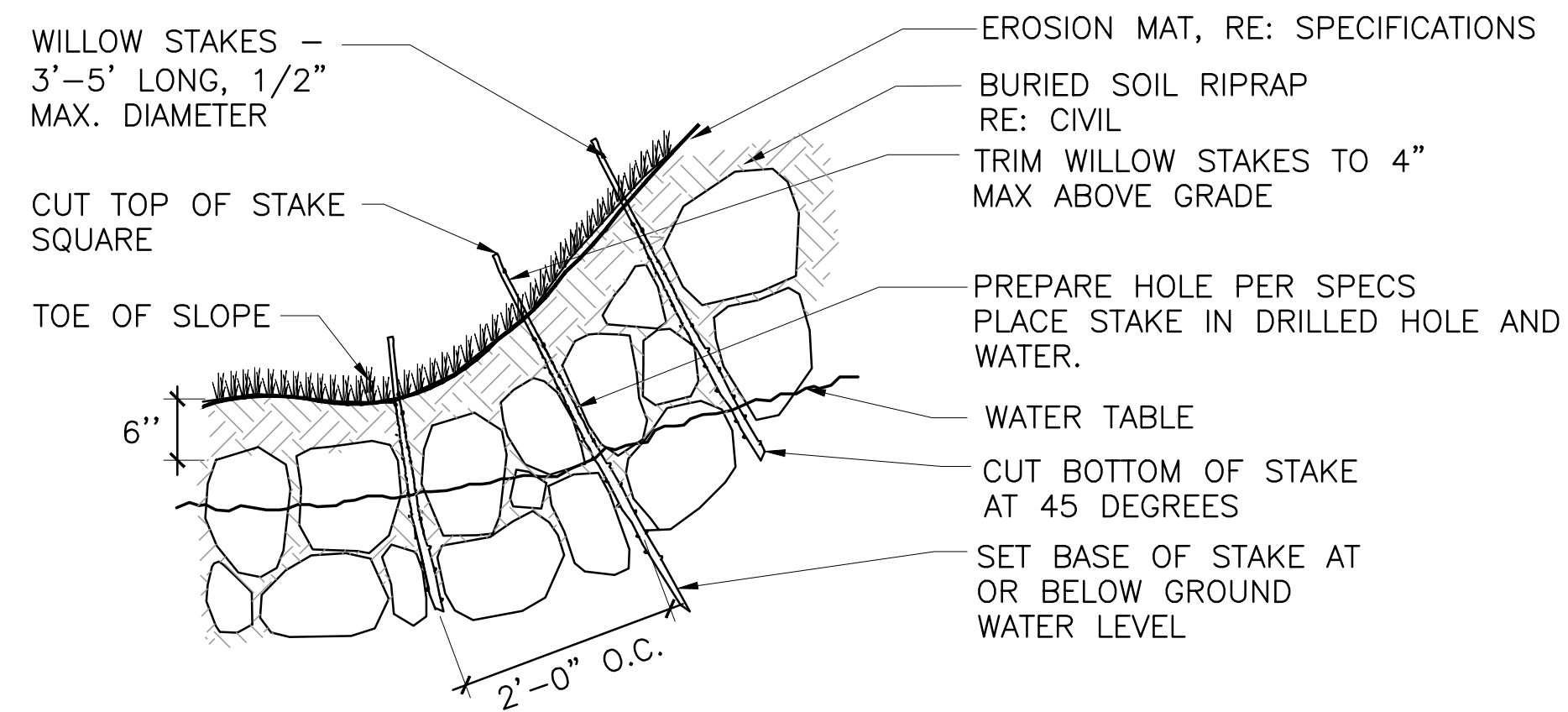

- NOTES:**
 1. REFER TO SPECIFICATION BEFORE PLANTING.
 2. CONDITIONS VARY, WILLOW STAKES MAY OCCUR IN AREAS OF EMBANKMENT, SOIL RIPRAP, AND EROSION MAT-SEE PLANS FOR SPECIFIC CONDITIONS.
 3. DIG TEST HOLE IN EACH AREA DESIGNATED FOR WILLOW STAKES TO DETERMINE DEPTH OF WATER TABLE. PLANT WILLOW STAKES SO THAT BOTTOM 6" OF STAKE (MIN.) IS BELOW WATER TABLE DEPTH.
 4. SOURCE FOR WILLOW STAKES TO BE APPROVED BY OWNER'S REPRESENTATIVE.
 5. WHEN HARVESTING WILLOW STAKES, CUT BOTTOM OF STAKE AT 45 DEGREES AND CUT TOP OF STAKE SQUARE. PLANT ANGLED END INTO THE GROUND, PLANT SHOULD BE PLACED IN THE SAME ORIENTATION AS IT WAS HARVESTED (PLANT RIGHT SIDE UP).
 6. WILLOW STAKES SHOULD ONLY BE COLLECTED WHEN THEY ARE DORMANT, APPROXIMATELY FROM NOVEMBER TO MARCH. IT IS THE CONTRACTOR'S RESPONSIBILITY TO COLLECT THE PROPER NUMBER OF STAKES AND STORE THEM IN AN APPROVED MANNER (SEE SPECIFICATIONS SECTION 910-WILLOW TRANSPLANTING).
 7. TWO TO FIVE BUD SCARS SHOULD BE ABOVE THE GROUND. APPROXIMATELY 80% OF THE PLANT SHOULD BE BELOW GRADE. ALL STAKES SHOULD BE SOAKED FOR A MINIMUM OF 24 HOURS BEFORE PLANTING.

05 WILLOW STAKE IN RIPRAP

SHEET NUMBERING ON LANDSCAPE AND IRRIGATION PLANS FROM ORIGINAL BID SET. ACTUAL SHEET NUMBER = SHEET NUMBER + 1. TOTAL NUMBER OF SHEETS = 32.



ASSOCIATES
 PLANNERS &
 LANDSCAPE
 ARCHITECTS
 303.628.0008

DATE	
DESCRIPTION OF REVISIONS	
NO.	
CALL UNCC TWO WORKING DAYS BEFORE YOU DIG 1-800-922-1987 UNIVERSITY OF COLORADO	
CITY AND COUNTY OF DENVER DEPARTMENT OF PUBLIC WORKS ENGINEERING DIVISION CAPITAL PROJECTS MANAGEMENT 2000 W. 3RD AVE. DENVER, CO 80223 TEL.: (303) 446-3617 FAX: (303) 446-3647	
HAMPDEN HEIGHTS STORM SEWER IMPROVEMENTS - PHASE III E. GIRARD AVE. OUTFALL PCO CONTROL NO: PILAR REVIEW NO:	PLANTING PLANS
DRAWN BY: KS	
DESIGNED BY: GD	
APPROVED BY: GD	
DRAWING NAME: L20 - PLANTING DETAILS	
DATE: 12/16/2014	
SHEET NO.:	23 of 31

IRRIGATION SCHEDULE				
SYMBOL	MANUFACTURER	MODEL NO.	DESCRIPTION	DETAIL NO.
	RAIN BIRD	1812 SAM PRS W/ U-SERIES NOZZ.	HI-POP SPRAY HEAD	9
	RAIN BIRD	1812 SAM PRS W/ VARIABLE ARC NOZZLES	HI-POP SPRAY HEAD	9
	RAIN BIRD	1812 SAM W/ R13-17 ROTARY NOZZLES	ROTARY HEADS	9
	HUNTER	I-25-06 W/ #18 NOZZLE	GEAR DRIVEN ROTOR	10
	TORO	SENTINEL - SBW24-U2/XB-SB18SS/PC/DG-VRA-FK-GFI	ELECTRIC CONTROLLER	20
	HUNTER	MINI-CLIK	RAIN SENSOR	24
	RAIN BIRD	PEB-PRS-D	ELECTRIC CONTROL VALVE	5 & 6
	BUCKNER	Q44LRCAR10 (WING-THING)	QUICK COUPLING VALVE	7
N/S	MACDONALD	AY 1" 3601 WITH BRASS SWING JOINT	MANUAL DRAIN VALVE	13
	BERMAD	410 NORMALLY OPEN - 2"	MASTER VALVE	21
	DATA INDUSTRIAL	228-PV - 1.5"	FLOW SENSOR	21
	ZURN WILKINS	375XL	BACKFLOW PREVENTER	PER DW #69
	MATCO-NORCA	10RS	GATE VALVE - 2" AND SMALLER	11
		CLASS 200 BE - 2 1/2" & SMALLER	PVC MAINLINE	1
		#100 NSF POLY	POLY LATERAL - 1" MINIMUM	1
		CLASS 200	PVC SLEEVING	2
			THRUST BLOCKS	3
			CONTROLLER & STATION NO.	
			CONTROL VALVE SIZE	
			CONTROLLER	
			NUMBER OF SPARE WIRES - 2 CONTROL AND 1 SPARE WIRES TO WHICH CONTROLLER - SEE CONSTRUCTION NOTES	

IRRIGATION CONSTRUCTION NOTES

- DRAWINGS AND BASE INFORMATION - ALL BASE AND PLANTING INFORMATION HAVE BEEN PROVIDED BY WENK ASSOCIATES. THE CONTRACTOR IS RESPONSIBLE TO NOTIFY HYDROSYSTEMS*KDI OF ANY DISCREPANCIES BETWEEN THE UTILITY OR PLANTING PLANS AND THE IRRIGATION PLAN. IF CONTRACTOR FAILS TO NOTIFY HYDROSYSTEMS*KDI AND MAKES CHANGES TO THE IRRIGATION SYSTEM DESIGN, HE ASSUMES ALL COSTS AND LIABILITIES ASSOCIATED WITH THOSE FIELD CHANGES. REFER TO SPECIFICATIONS FOR ADDITIONAL PROJECT REQUIREMENTS.
- SYSTEM PRESSURE - HYDROSYSTEMS*KDI HAS CONTACTED THE LOCAL WATER DISTRICT THAT SERVES THIS SITE AND THEY HAVE BEEN TOLD THAT THE STATIC WATER PRESSURE IN THIS AREA SHOULD BE 108 PSI. THE CONTRACTOR IS RESPONSIBLE TO FIELD VERIFY PRESSURE PRIOR TO COMMENCING ANY CONSTRUCTION AND NOTIFY HYDROSYSTEMS*KDI OF ANY VARIANCE FROM THE STATED PRESSURE. IF CONTRACTOR FAILS TO FIELD VERIFY PRESSURE AND/OR NOTIFY HYDROSYSTEMS*KDI OR ANY VARIATIONS FROM THIS PRESSURE, THEN HE ASSUMES ALL CONSTRUCTION AND ENGINEERING COSTS ASSOCIATED WITH SYSTEM MODIFICATIONS REQUIRED TO ACCOMMODATE ACTUAL SITE PRESSURE. THIS SYSTEM HAS BEEN DESIGNED FOR A REQUIRED STATIC PRESSURE OF 108 PSI MINIMUM.
- IRRIGATION SYSTEM OPERATION INTENT - THIS IRRIGATION SYSTEM HAS BEEN DESIGNED TO IRRIGATE THE ESTABLISHED LANDSCAPE WITHIN A THREE NIGHT PER WEEK, EIGHT HOUR PER NIGHT WATERING WINDOW. ESTABLISHMENT WATERING WILL REQUIRE UP TO TWICE AS MUCH IRRIGATION FOR A FOUR TO SIX WEEK PERIOD. THE DESIGN IS BASED ON THE FOLLOWING PROJECTED WEEKLY APPLICATION RATES AFTER ESTABLISHMENT. THESE FIGURES ARE BASED ON A 30-YEAR AVERAGE WEATHER DATA AND WILL NEED TO BE ADJUSTED DUE TO SEASONAL CHANGES AND WEATHER CONDITIONS ABOVE AND BELOW THE AVERAGE VALUES UTILIZED.

BLUEGRASS TURF	2.22" PER WEEK PEAK SEASON
ORNAMENTAL PLANTINGS	1.29" PER WEEK PEAK SEASON
NATIVE SEED MIXES	1.19" PER WEEK PEAK SEASON (TWO SEASONS)

 NOTE: IT IS THE INTENT OF THIS DESIGN THAT NATIVE AREAS WOULD ONLY BE IRRIGATED FOR ESTABLISHMENT.
- EQUIPMENT INSTALLATION - IT IS THE INTENT OF THIS DESIGN THAT ALL IRRIGATION EQUIPMENT BE INSTALLED WITHIN PROPERTY LIMITS AND WITHIN LANDSCAPED AREAS. ANY EQUIPMENT SHOWN OUTSIDE OF THESE LIMITS IS SHOWN IN THAT LOCATION FOR GRAPHICAL CLARITY ONLY. ALL VALVE BOXES SHALL BE INSTALLED A MINIMUM OF 2'-0" FROM EDGE OF ANY PAVED SURFACES. ALL VALVE BOXES SHALL BE PLACED A MINIMUM OF 3'-0" FROM THE CENTERLINE OF ANY DRAINAGE SWALE.
- SLEEVING - ALL SLEEVING UNDER PAVED SURFACES SHOWN ON PLANS IS BY CONTRACTOR UNLESS OTHERWISE NOTED. SLEEVING SHALL BE INSTALLED IN THE SIZES AND QUANTITIES SHOWN ON PLANS OR BASED ON THE SCHEDULE BELOW. WHERE SLEEVES ARE SHOWN, BUT NOT LABELED, FOLLOW THE SCHEDULE BELOW. ALL MAINLINE, CONTROL WIRES AND DRIP LINES UNDER PAVED SURFACES ARE TO BE INSTALLED IN SLEEVING.

SLEEVED PIPE SIZE/WIRE QUANTITY REQUIRED SLEEVE SIZE & QUANTITY	
3/4" - 1 1/2" PIPING	2" PVC (1)
1 1/2" - 2" PIPING	4" PVC (1)
2 1/2" - 3" PIPING	6" PVC (1)
1-50 CONTROL WIRES	3" PVC (1)
- MANUAL DRAIN VALVES - CONTRACTOR TO INSTALL ONE MANUAL DRAIN VALVE ON PRESSURE SUPPLY LINE DIRECTLY DOWNSTREAM OF BACKFLOW PREVENTER AND AT ALL LOW POINTS AND DEAD ENDS OF PRESSURE SUPPLY PIPING TO INSURE COMPLETE DRAINAGE OF SYSTEM. CONTRACTOR SHALL BE RESPONSIBLE FOR DETERMINING THESE LOCATIONS IN-FIELD AND INSTALLATION LOCATIONS SHALL BE NOTED ON AS-BUILTS.
- ROTARY SPRAY NOZZLES - CONTRACTOR TO INSTALL PLASTIC ROTARY NOZZLES ON ALL POP-UP SPRAY HEADS. INSTALL R13-18 SERIES NOZZLES ON HEADS SPACED 13' TO 17'. INSTALL R17-24 SERIES NOZZLES ON ALL HEADS SPACED AT 18' TO 23'. R-VAN SERIES VARIABLE ARC SHOULD BE UTILIZED ADJACENT TO CURVILINEAR SHRUB BEDS OR FOR ANY ANGLES THAT ARE NOT A STANDARD NOZZLE ANGLE.
- SPARE CONTROL WIRES - CONTRACTOR SHALL EXTEND THREE SPARE WIRES (ONE COMMON AND 2 CONTROL WIRES) FROM EACH CONTROLLER TO THE END OF THE MAINLINE SERVING THAT CONTROLLER OR AS SHOWN ON THE PLANS. INSTALL SPARE WIRES IN 10" ROUND VALVE BOX WITH QUICK COUPLING VALVE. REFER TO SPECIFICATIONS FOR WIRE COLOR. SEE IRRIGATION SCHEDULE FOR ADDITIONAL INFORMATION.
- ADJUSTMENT - CONTRACTOR SHALL FINE TUNE/ADJUST THE IRRIGATION SYSTEM TO REDUCE/AVOID OVERSPRAY ONTO HARD SURFACES BY ADJUSTING NOZZLE DIRECTION AND NOZZLE RADIUS.
- UNLABELED PIPING - ALL UNLABELED LATERAL PIPING SHALL BE 1" MINIMUM UNLESS OTHERWISE NOTED.

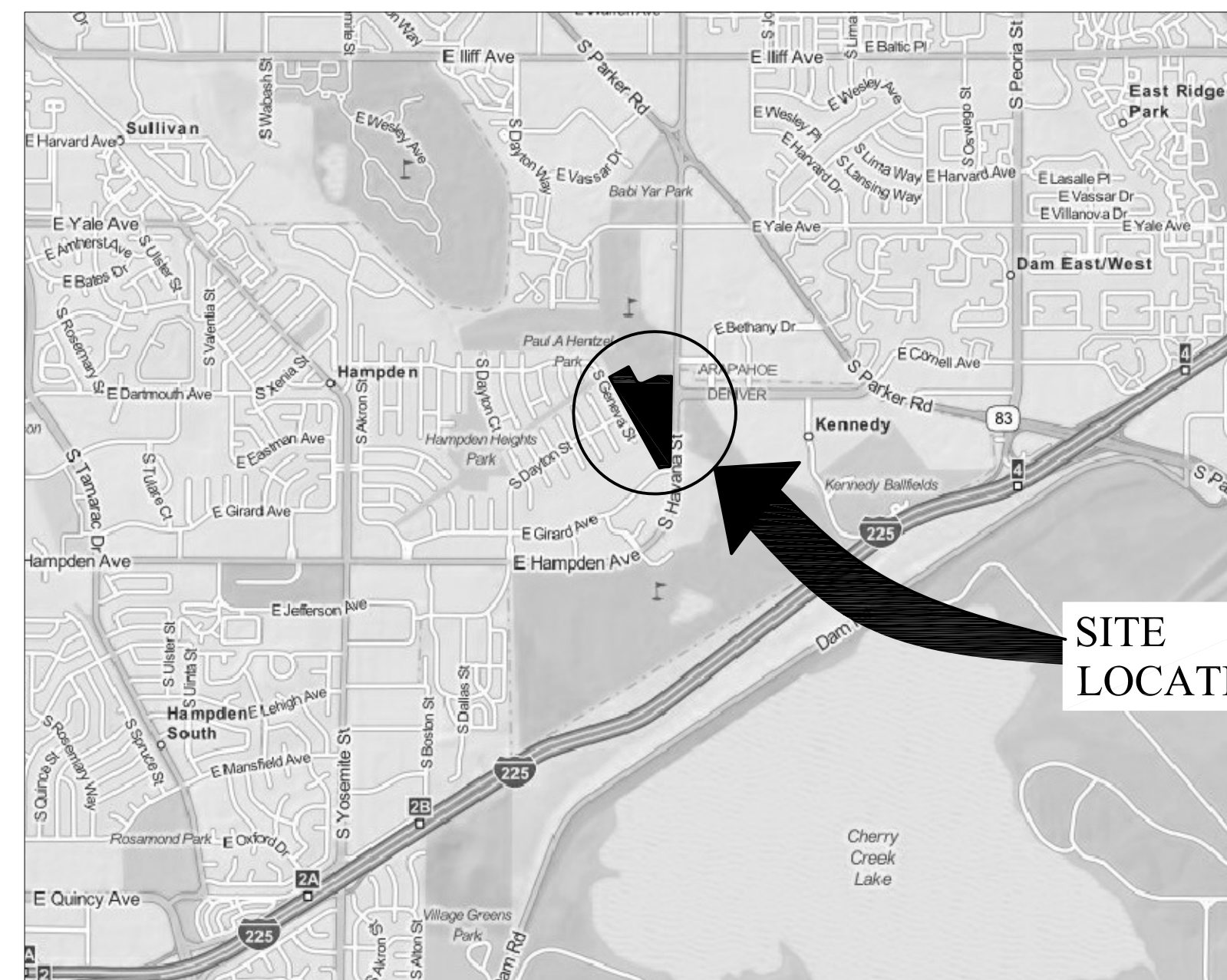

HAVANA STREET AND GIRARD AVENUE

A PARCEL OF LAND LOCATED IN THE NORTHEAST AND SOUTHEAST QUARTER OF SECTION 34, TOWNSHIP 4 SOUTH, RANGE 67 WEST, OF THE 6TH PRINCIPAL MERIDIAN, CITY AND COUNTY OF DENVER, STATE OF COLORADO

3333 SOUTH HAVANA STREET

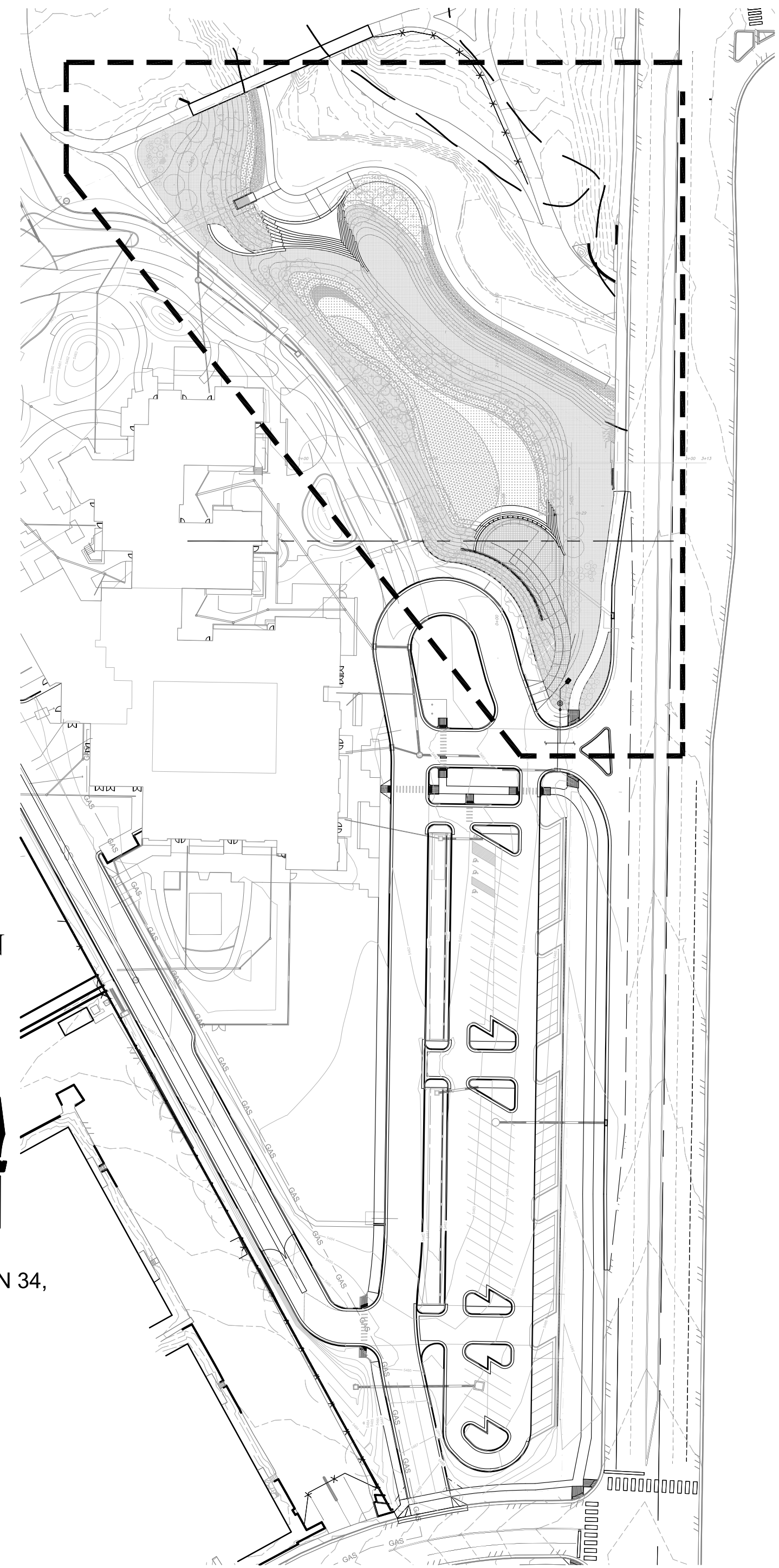

KEY PLAN
N.T.S.

LIST OF IRRIGATION DRAWINGS

- 24 SHEET INDEX & NOTES
- 25 IRRIGATION PLAN
- 26 IRRIGATION PLAN & DETAILS
- 27-28 IRRIGATION DETAILS
- 29 IRRIGATION CHARTS
- 30-31 DENVER WATER INFORMATION

SHEET NUMBERING ON LANDSCAPE AND IRRIGATION PLANS FROM ORIGINAL BID SET. ACTUAL SHEET NUMBER = SHEET NUMBER + 1. TOTAL NUMBER OF SHEETS = 32.



Know what's below.
Call before you dig.
CALL 3 BUSINESS DAYS IN ADVANCE BEFORE YOU DIG OR EXCAVATE FOR THE MARKING OF UNDERGROUND MEMBER UTILITIES.

HydroSystems-KDI, Inc.
860 Tabor Street, Suite 200
Lakewood, Colorado 80401
303-980-5327
303-980-5384 (fax)

NO.	DESCRIPTION OF REVISIONS	DATE	BY

CALL UNCC
TWO WORKING DAYS
BEFORE YOU DIG
1-800-922-1987
UTILITY NOTIFICATION CENTER OF
COLORADO



CITY AND COUNTY OF DENVER
DEPARTMENT OF PUBLIC WORKS
ENGINEERING DIVISION
CAPITAL PROJECTS MANAGEMENT
2000 W. 3RD AVE. DENVER, CO 80223
TEL.: (303) 446-3617 FAX: (303) 446-3647

HAMPDEN HEIGHTS STORM SEWER
IMPROVEMENTS - PHASE III
E. GIRARD AVE. OUTFALL
PCO CONTROL NO:
PILAR REVIEW NO:
IRRIGATION PLAN

DRAWN BY:	AMC
DESIGNED BY:	AMC
APPROVED BY:	KJD
DRAWING NAME:	5234-HHS-Pond-IRR-CD-DPR Set.dwg
DATE:	12/11/14
SHEET NO:	24 of 31





LIST OF IRRIGATION DRAWINGS

24	SHEET INDEX & NOTES
25	IRRIGATION PLAN
26	IRRIGATION PLAN & DETAILS
27-28	IRRIGATION DETAILS
29	IRRIGATION CHARTS
30-31	DENVER WATER INFORMATION

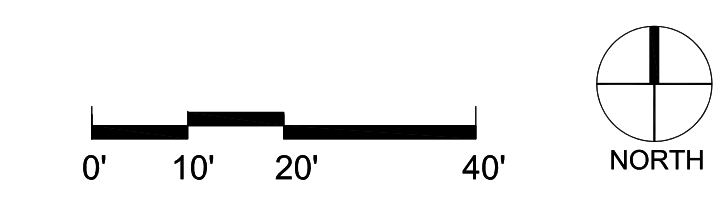
SHEET NUMBERING ON LANDSCAPE AND IRRIGATION PLANS FROM ORIGINAL BID SET. ACTUAL SHEET NUMBER = SHEET NUMBER + 1. TOTAL NUMBER OF SHEETS = 32.

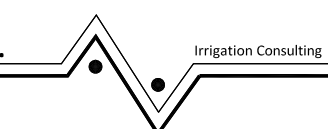

HydroSystems-KDI, Inc.  Irrigation Consulting
 860 Tabor Street, Suite 200
 Lakewood, Colorado 80401
 303-980-5327
 303-980-5384 (fax)

NO.	DESCRIPTION OF REVISIONS	DATE	BY
			
<p>CALL UNCC TWO WORKING DAYS BEFORE YOU DIG 1-800-922-1987 UTILITY WORK CENTER OF COLORADO</p>			
<p>CITY AND COUNTY OF DENVER DEPARTMENT OF PUBLIC WORKS ENGINEERING DIVISION CAPITAL PROJECTS MANAGEMENT 2000 W. 3RD AVE. DENVER, CO 80223 TEL.: (303) 446-3617 FAX: (303) 446-3647</p>			
<p>HAMPDEN HEIGHTS STORM SEWER IMPROVEMENTS - PHASE III E. GIRARD AVE. OUTFALL</p>			
<p>PCO CONTROL NO: PILAR REVIEW NO: IRRIGATION PLAN</p>			
<p>DRAWN BY: AMC</p>			
<p>DESIGNED BY: AMC</p>			
<p>APPROVED: KJD</p>			
<p>DRAWING NAME: 5234-HHS-Pond-IRR-CD-DPR Set.dwg</p>			
<p>DATE: 12/11/14</p>			
<p>SHEET NO. 25 of 31</p>			

CONTROLLER "B"

CONTRACTOR SHALL INSTALL NEW TORO SENTINEL 24 STATION FIELD UNIT AND ENCLOSURE AT APPROXIMATE LOCATION SHOWN (MODEL NUMBER: SBW24-U2/XB-SB18SS/PC/DG-VRA-FK-GFI). CONTROLLER SHALL BE REMOTE READY. 120 VOLT POWER FROM A DEDICATED CIRCUIT #124 WITHIN SCHOOL MAIN ELECTRICAL IS AVAILABLE WITHIN 50 FT. OF CONTROLLER LOCATION (BY OTHERS, RE: ELECTRICAL). ELECTRICAL POWER CONNECTION TO CONTROLLER AND ENCLOSURE IS BY CONTRACTOR WITH WORK CONFORMING TO LOCAL CODES. CONTRACTOR SHALL LOCATE (1) PAIGE 7171D-A SIGNAL CABLE FROM FLOW SENSOR AND FOUR (4) #14 AWG UFUL WIRES (ONE GREEN COMMON, ONE BLUE HOT, ONE GREEN EXTRA COMMON AND ONE EXTRA BLUE HOT) FROM THE MASTER VALVE FOR CONTROLLER "B". CONNECT WIRES TO THE APPROPRIATE SENSOR INPUT PORTS. FEES AND PERMITS ASSOCIATED WITH WORK ARE TO BE OBTAINED AND PAID BY CONTRACTOR. FINAL CONTROLLER LOCATION SHALL BE APPROVED BY PROJECT MANAGER PRIOR TO INSTALLATION. MOUNT ONE HUNTER WIRELESS RAIN CLIK DEVICE ON POLE WHERE THERE IS 20 FT. OF CLEARANCE FROM ANY OVERHANG OR OBSTRUCTION FEATURE. INSTALL RAIN SENSOR RECEIVER IN CONTROLLER ENCLOSURE. FINAL RAIN SENSOR AND CONTROLLER LOCATIONS SHALL BE APPROVED BY PROJECT MANAGER PRIOR TO INSTALLATION. CONTRACTOR SHALL CONTACT BRANDON GULLY (303-961-6959) FOR RADIO FREQUENCY TEST PRIOR TO ORDERING, AND FOR FINAL CONNECTION AND PROGRAMMING OF UNIT TO DENVER PARKS CENTRAL CONTROL.

POINT OF CONNECTION #2 - 1.5"

PEAK FLOW REQUIREMENT: 41 GPM. REQUIRED STATIC PRESSURE: 100 PSI MIN.
 CONTRACTOR SHALL INSTALL ONE 1.5" METER PIT AND SERVICE LINE FROM 8" C900 WATER LINE AT THIS LOCATION PER DENVER WATER REQUIREMENTS. REFER TO SHEETS 30 AND 31 FOR INSTALLATION REQUIREMENTS. DENVER WATER WILL INSTALL TAP WITHIN WATERLINE. INSTALL 1.5" METER WITHIN PIT AND EXTEND 1.5" TYPE K SOFT COPPER AT 54" MINIMUM DEPTH 5' PAST METER PIT PRIOR TO ANY BENDS, UPSIZING, VALVES OR FITTINGS TO BACKFLOW PREVENTER LOCATION AS SHOWN. INSTALL ONE 1.5" STOP AND WASTE VALVE, AND ONE 1.5" REDUCED PRESSURE BACKFLOW PREVENTER WITH PROTECTIVE ENCLOSURE. CONVERT TO 2" PVC MAINLINE, ONE 2" MASTER VALVE, ONE 2" FLOW SENSOR AND EXTEND PVC MAINLINE AS SHOWN. EXTEND ONE PAIGE 7171D-A SIGNAL CABLE FROM FLOW SENSOR TO DATA RETRIEVAL UNIT LOCATED IN CONTROLLER "B". EXTEND 4 UFUL#14 WIRE (ONE GREEN COMMON, ONE BLUE HOT, ONE GREEN EXTRA COMMON AND ONE EXTRA BLUE HOT) AND CONNECT 2 OF THE WIRES FROM THE MASTER VALVE TO THE DATA RETRIEVAL BOARD IN CONTROLLER "B". SEE DETAIL SHEET FOR REQUIRED PIPE LENGTHS UPSTREAM AND DOWNSTREAM OF FLOW SENSING UNIT. WORK SHALL CONFORM TO LOCAL CODE. FEES AND PERMITS ASSOCIATED WITH WORK ARE TO BE OBTAINED AND PAID FOR BY CONTRACTOR. ANY CHANGE TO BACKFLOW PREVENTER LOCATION SHALL BE REVIEWED AND APPROVED BY PROJECT MANAGER PRIOR TO INSTALLATION. IT IS THE CONTRACTOR'S RESPONSIBILITY TO VERIFY THE PRESSURE AT THE BACKFLOW PREVENTER IS AS STATED. IF THE PRESSURE VARIES FROM THE EXPECTED PRESSURE, THE CONTRACTOR SHALL CONTACT HYDROSYSTEMS*KDI. THE CONTRACTOR SHALL PROVIDE DENVER PARKS STAFF WRITTEN DOCUMENTATION OF THE STATIC WATER PRESSURE AT THE BACKFLOW PREVENTER.



MATCHLINE "A"

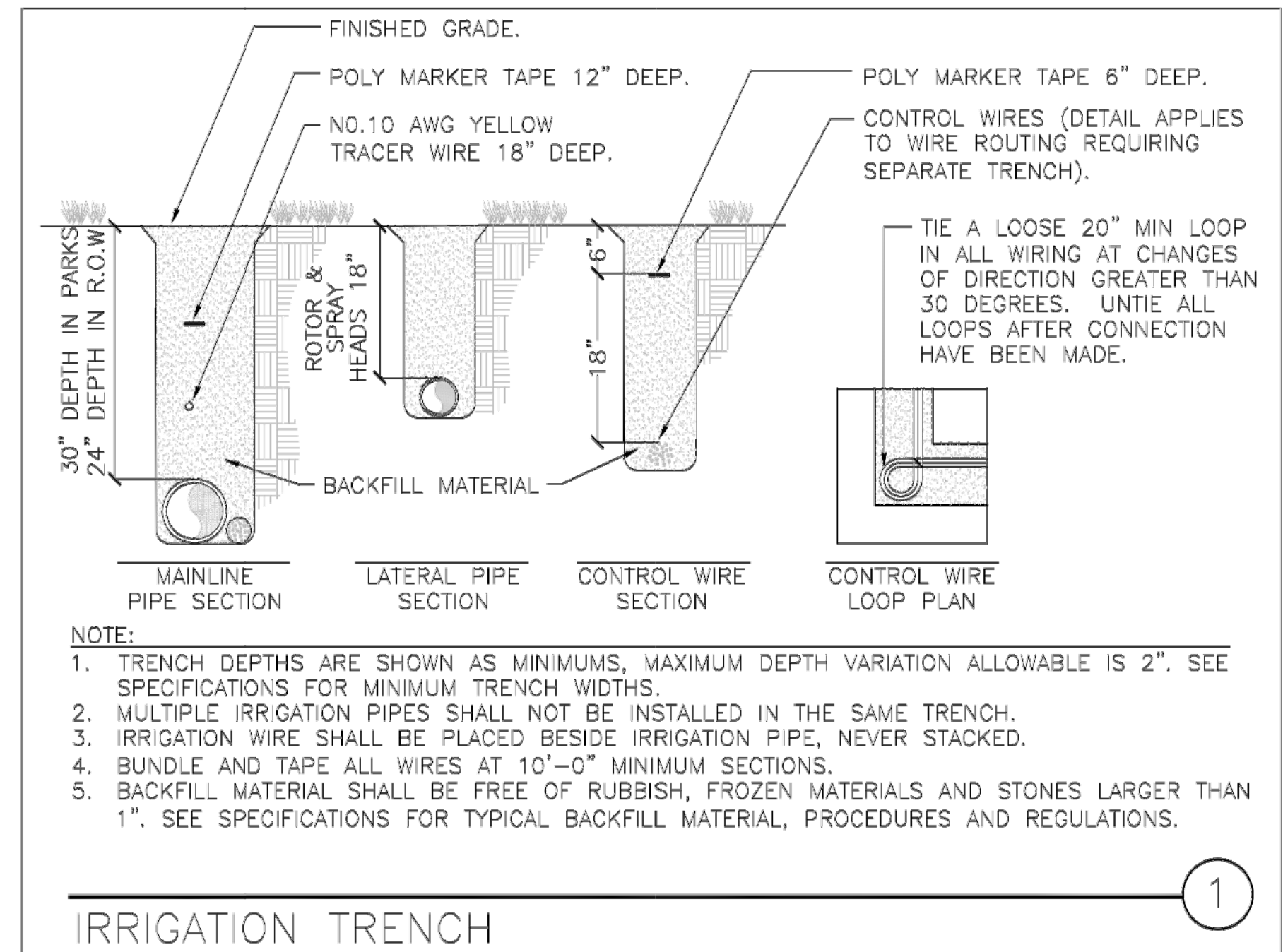

- NOTE:**
- TRENCH DEPTHS ARE SHOWN AS MINIMUMS, MAXIMUM DEPTH VARIATION ALLOWABLE IS 2". SEE SPECIFICATIONS FOR MINIMUM TRENCH WIDTHS.
 - MULTIPLE IRRIGATION PIPES SHALL NOT BE INSTALLED IN THE SAME TRENCH.
 - IRRIGATION WIRE SHALL BE PLACED BESIDE IRRIGATION PIPE, NEVER STACKED.
 - BUNDLE AND TAPE ALL WIRES AT 10'-0" MINIMUM SECTIONS.
 - BACKFILL MATERIAL SHALL BE FREE OF RUBBISH, FROZEN MATERIALS AND STONES LARGER THAN 1". SEE SPECIFICATIONS FOR TYPICAL BACKFILL MATERIAL, PROCEDURES AND REGULATIONS.

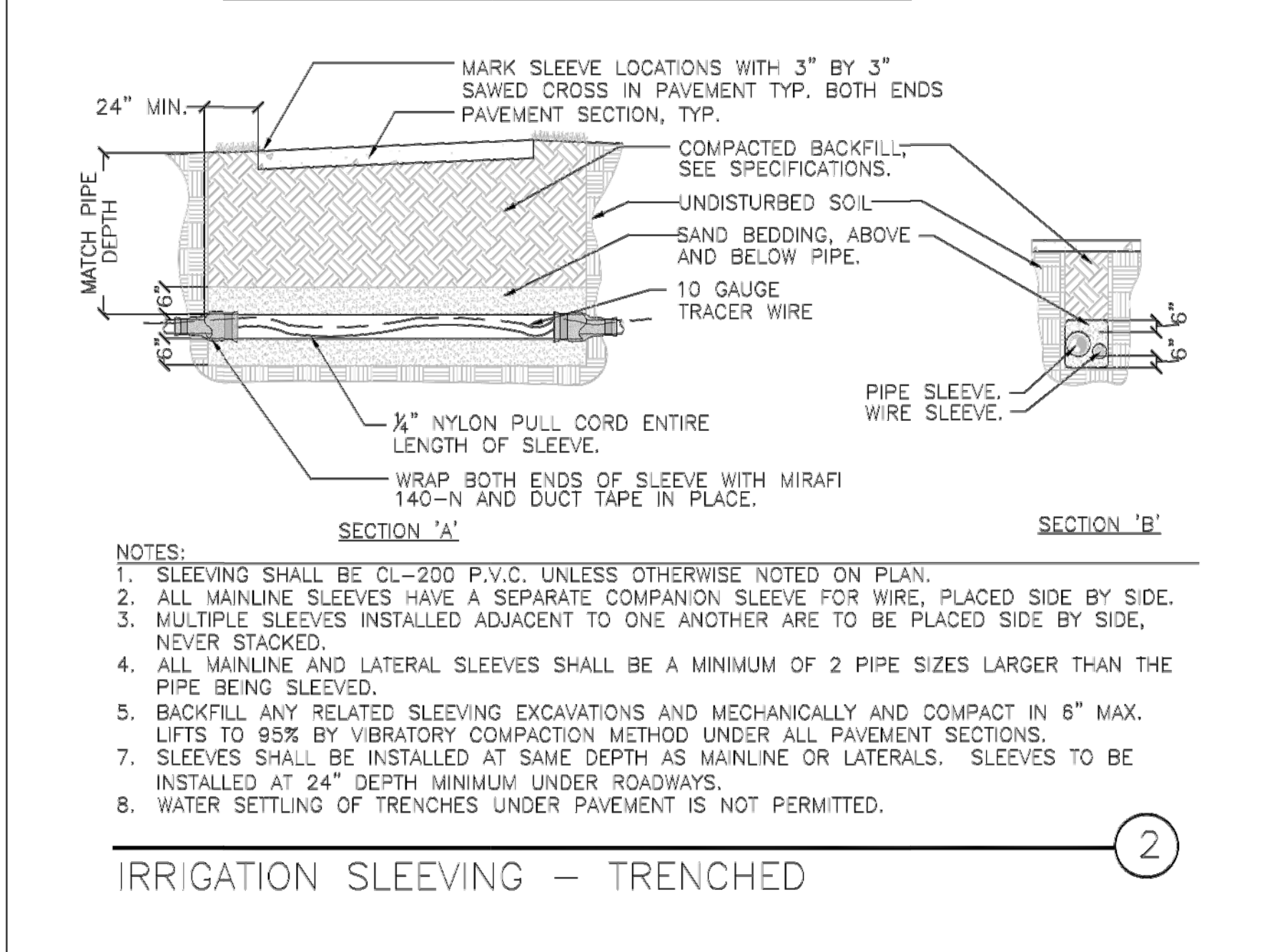

- NOTES:**
- SLEEVING SHALL BE CL-200 P.V.C. UNLESS OTHERWISE NOTED ON PLAN.
 - ALL MAINLINE SLEEVES HAVE A SEPARATE COMPANION SLEEVE FOR WIRE, PLACED SIDE BY SIDE.
 - MULTIPLE SLEEVES INSTALLED ADJACENT TO ONE ANOTHER ARE TO BE PLACED SIDE BY SIDE, NEVER STACKED.
 - ALL MAINLINE AND LATERAL SLEEVES SHALL BE A MINIMUM OF 2 PIPE SIZES LARGER THAN THE PIPE BEING SLEEVED.
 - BACKFILL ANY RELATED SLEEVING EXCAVATIONS AND MECHANICALLY AND COMPACT IN 6" MAX. LIFTS TO 95% BY VIBRATORY COMPACTION METHOD UNDER ALL PAVEMENT SECTIONS.
 - SLEEVES SHALL BE INSTALLED AT SAME DEPTH AS MAINLINE OR LATERALS. SLEEVES TO BE INSTALLED AT 24" DEPTH MINIMUM UNDER ROADWAYS.
 - WATER SETTLING OF TRENCHES UNDER PAVEMENT IS NOT PERMITTED.

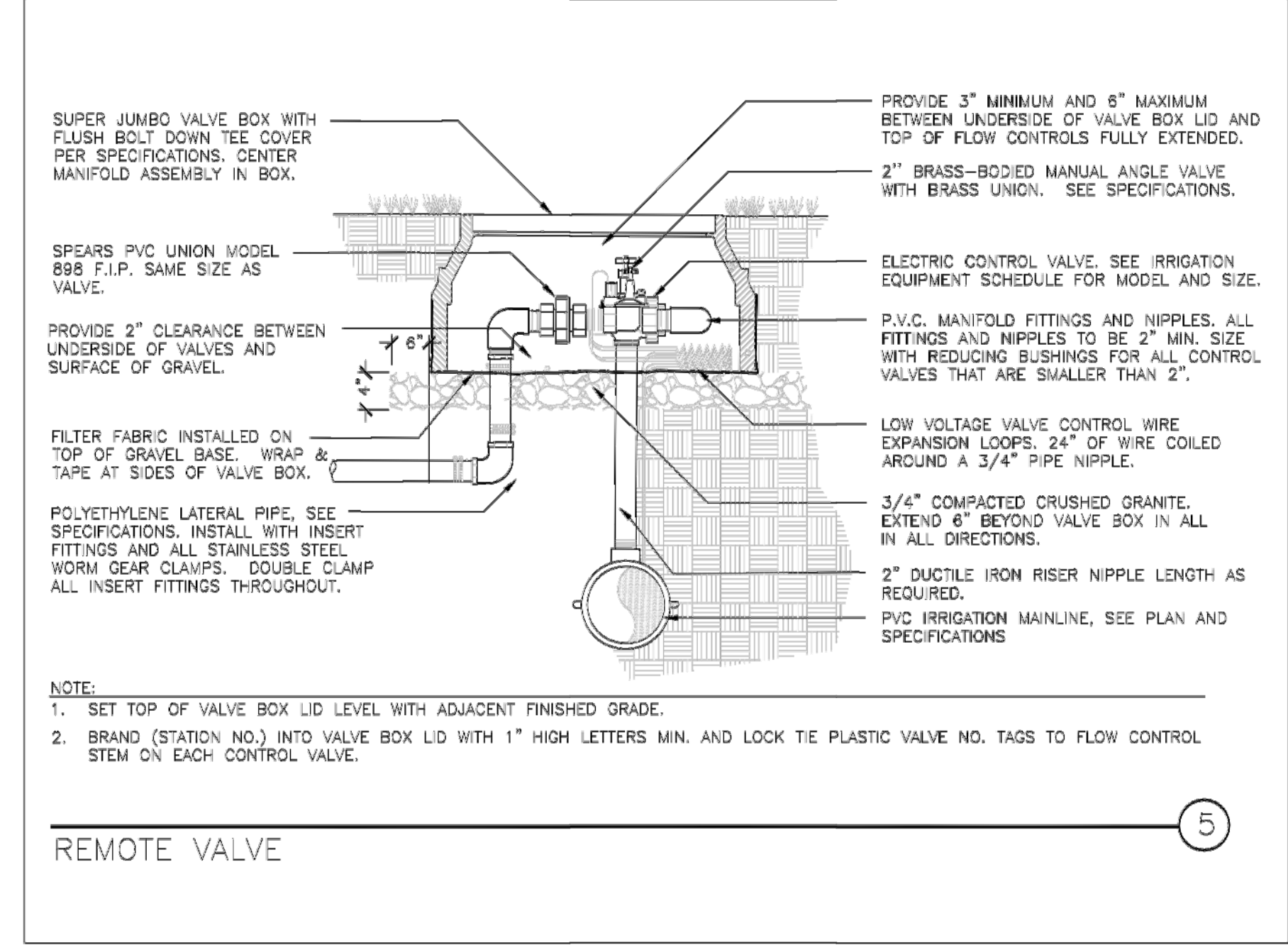
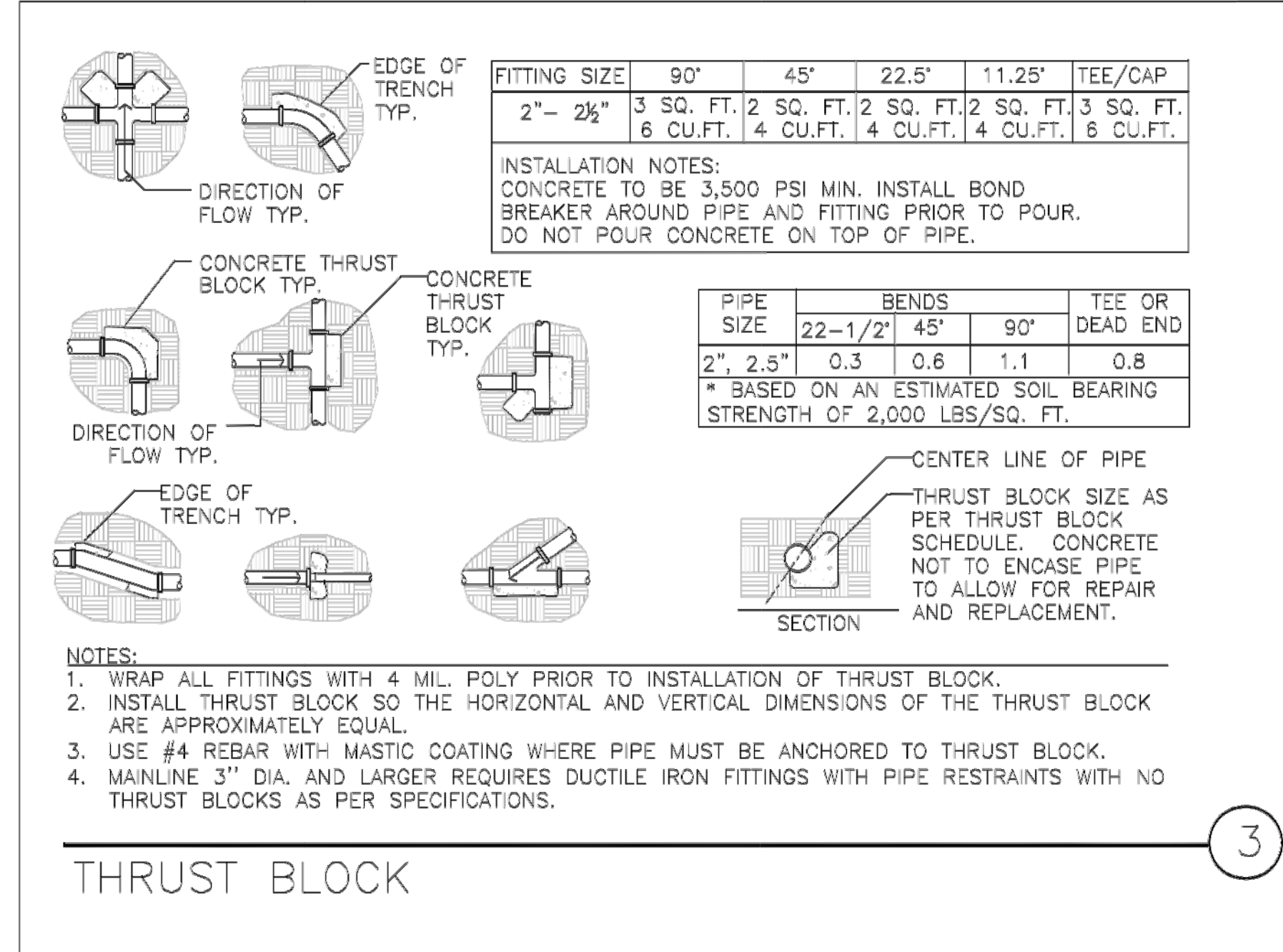

LIST OF IRRIGATION DRAWINGS

24	SHEET INDEX & NOTES
25	IRRIGATION PLAN
26	IRRIGATION PLAN & DETAILS
27-28	IRRIGATION DETAILS
29	IRRIGATION CHARTS
30-31	DENVER WATER INFORMATION



HydroSystems-KDI, Inc.
 860 Tabor Street, Suite 200
 Lakewood, Colorado 80401
 303-980-5327
 303-980-5384 (fax)

DATE	BY
DESCRIPTION OF REVISIONS	
NO.	
CALL UNCC TWO WORKING DAYS BEFORE YOU DIG 1-800-922-1087 UTILITY WORK CENTER OF COLORADO	
CITY AND COUNTY OF DENVER DEPARTMENT OF PUBLIC WORKS ENGINEERING DIVISION CAPITAL PROJECTS MANAGEMENT 2000 W. 3RD AVE. DENVER, CO 80223 TEL.: (303) 446-3617 FAX: (303) 446-3647	
HAMPDEN HEIGHTS STORM SEWER IMPROVEMENTS - PHASE III E. GIRARD AVE. OUTFALL PCO CONTROL NO: PILAR REVIEW NO: IRRIGATION PLAN	
DRAWN BY: AMC	
DESIGNED BY: AMC	
APPROVED BY: KJD	
DRAWING NAME: 5234-HHS-Pond-IRR-CD-DPR Set.dwg	
DATE: 12/11/14	
SHEET NO. 26 of 31	

SHEET NUMBERING ON LANDSCAPE AND IRRIGATION PLANS FROM ORIGINAL BID SET. ACTUAL SHEET NUMBER = SHEET NUMBER + 1. TOTAL NUMBER OF SHEETS = 32.

C:\DATA\DWG\DWG-AMBERV\5234-HAMPDEN HEIGHTS STORM SEWER\5234-HHS-POND-IRR-CD-DPR-SET.DWG
 PLOT DATE: December 17, 2014

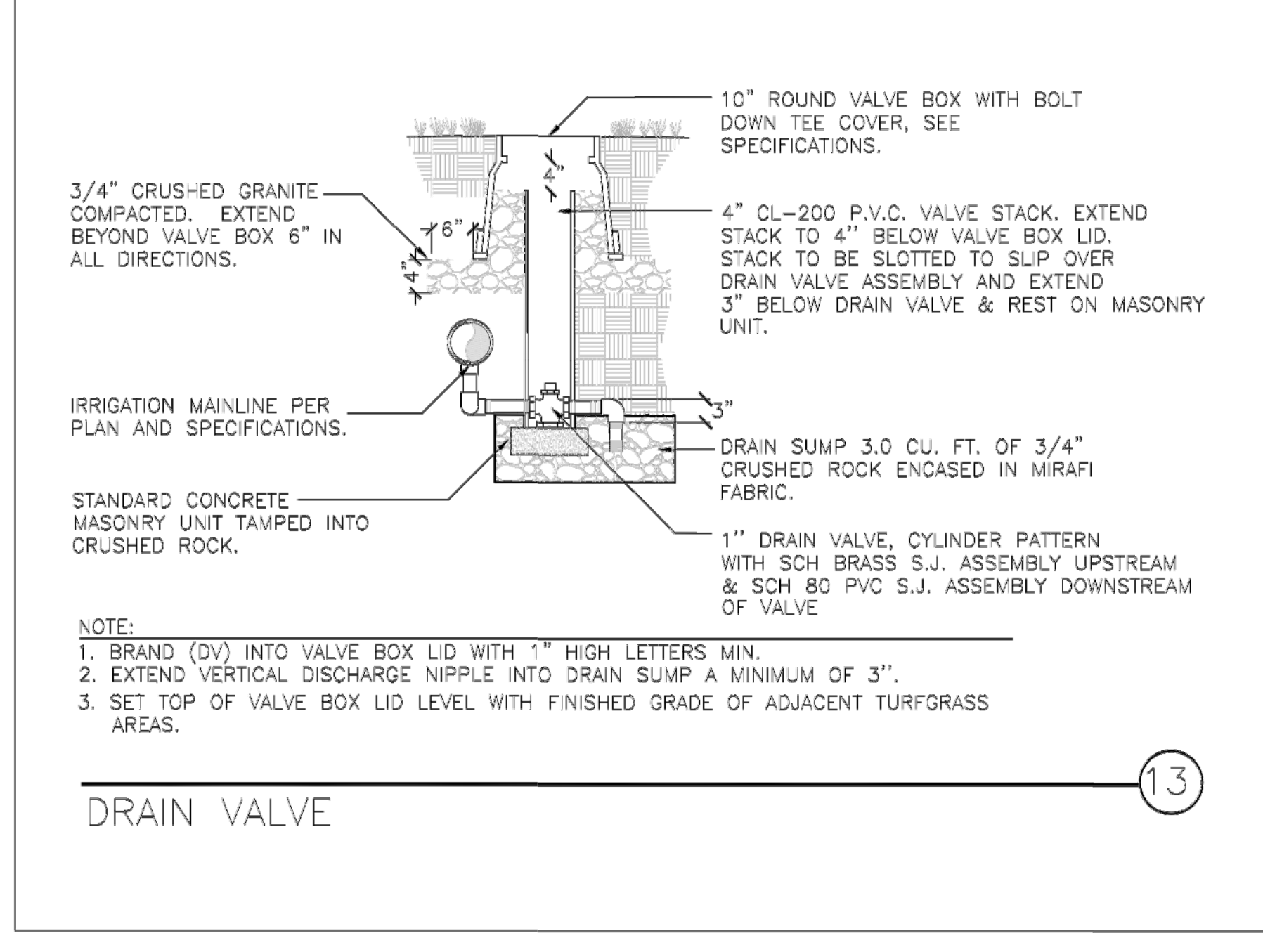
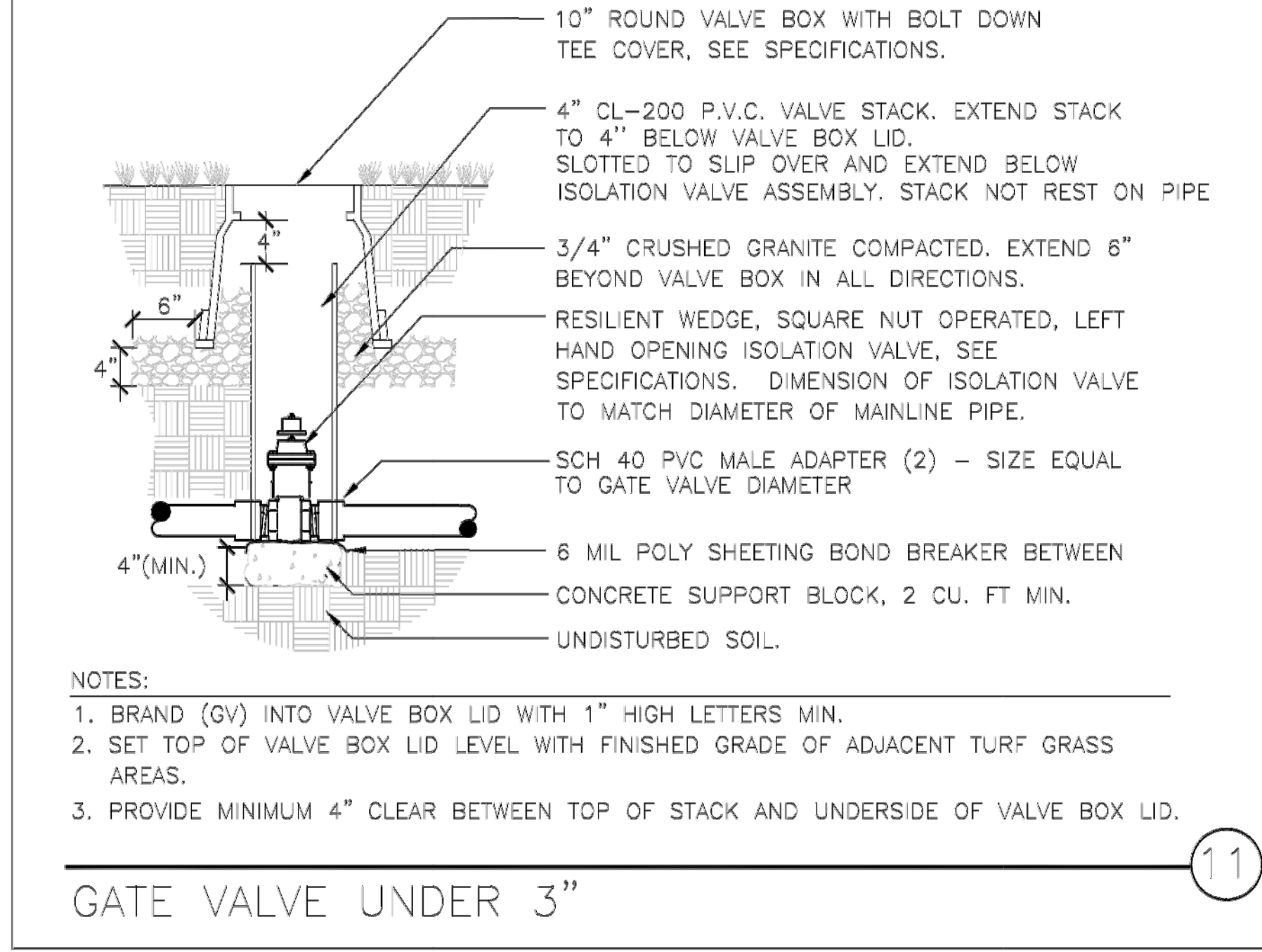
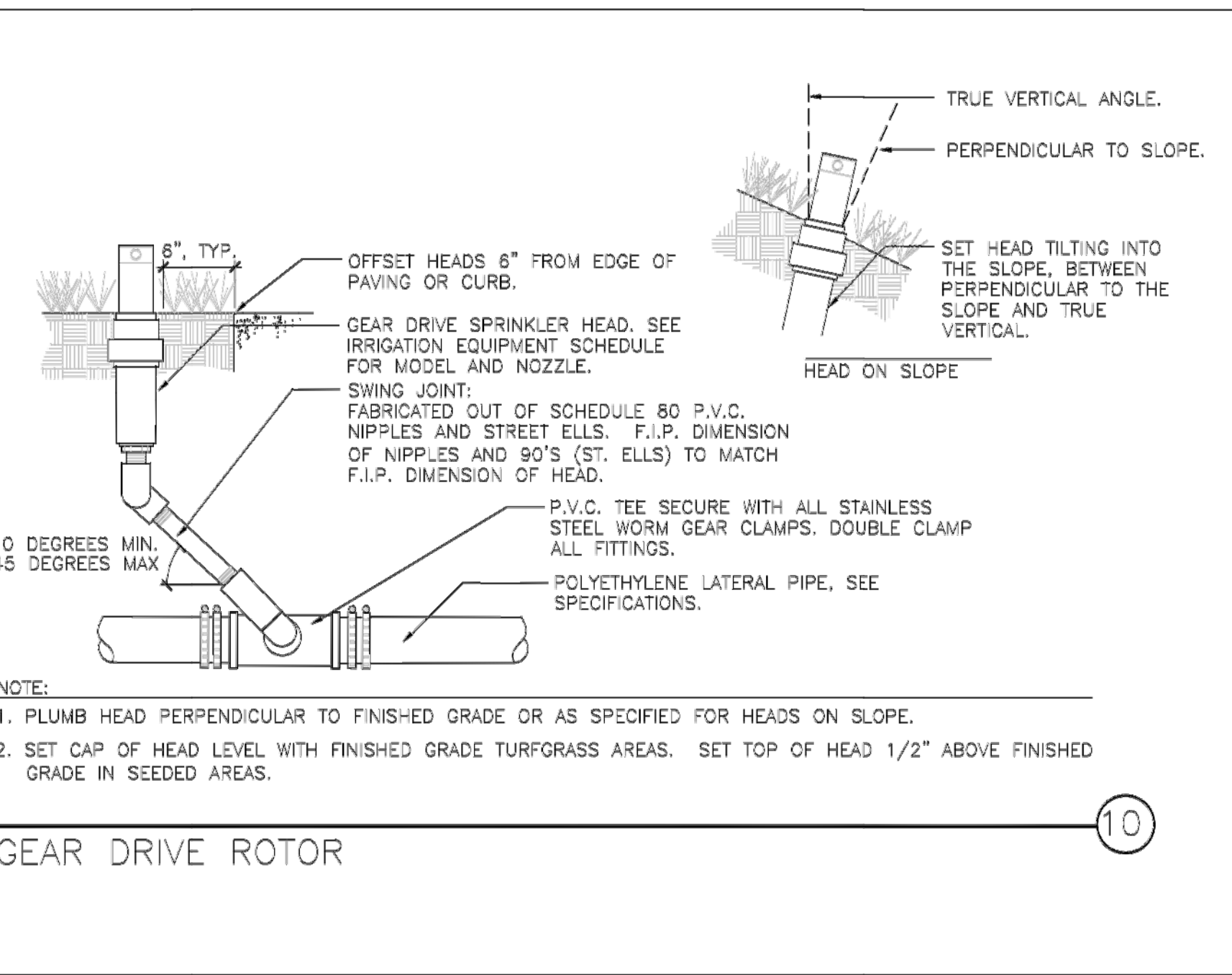
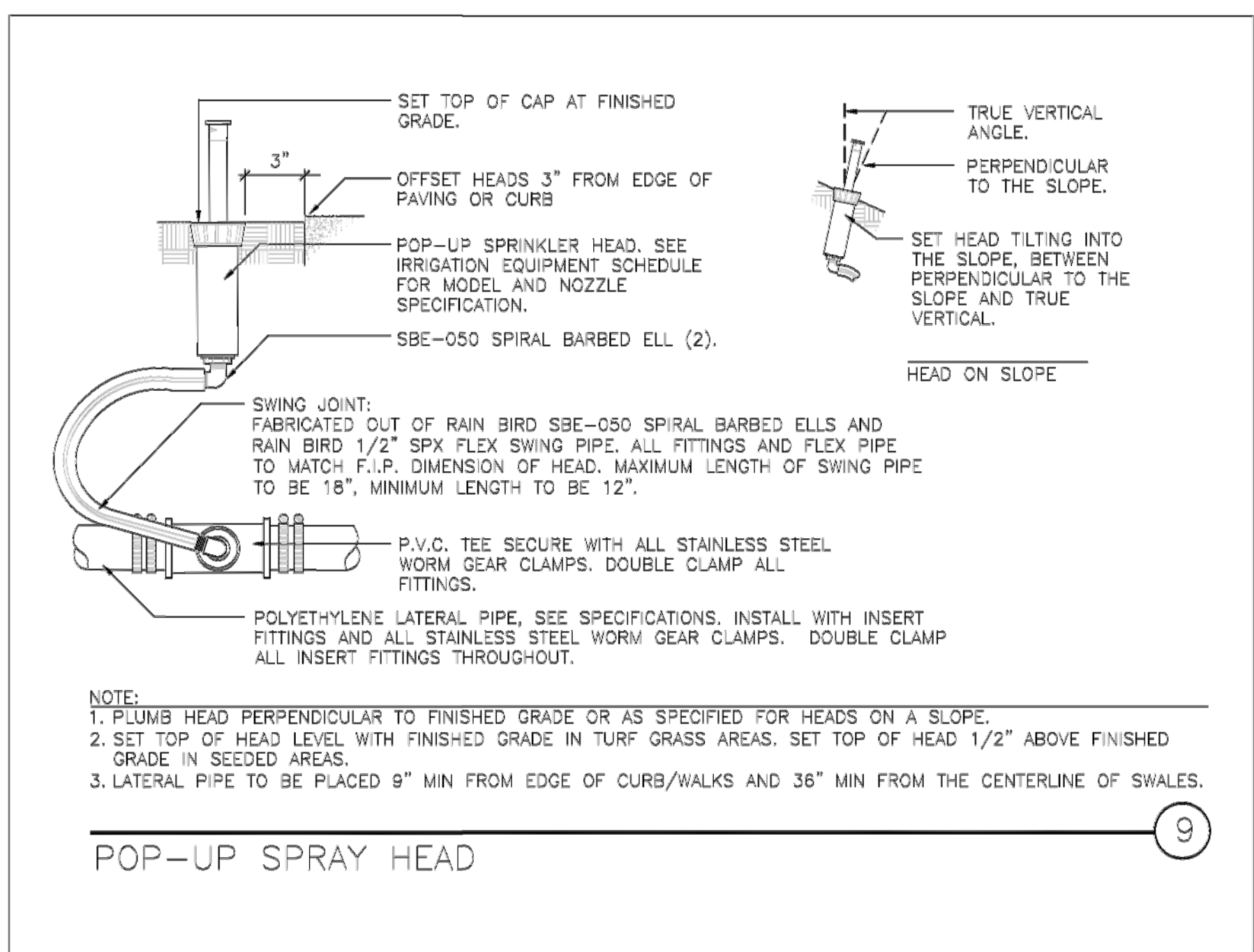
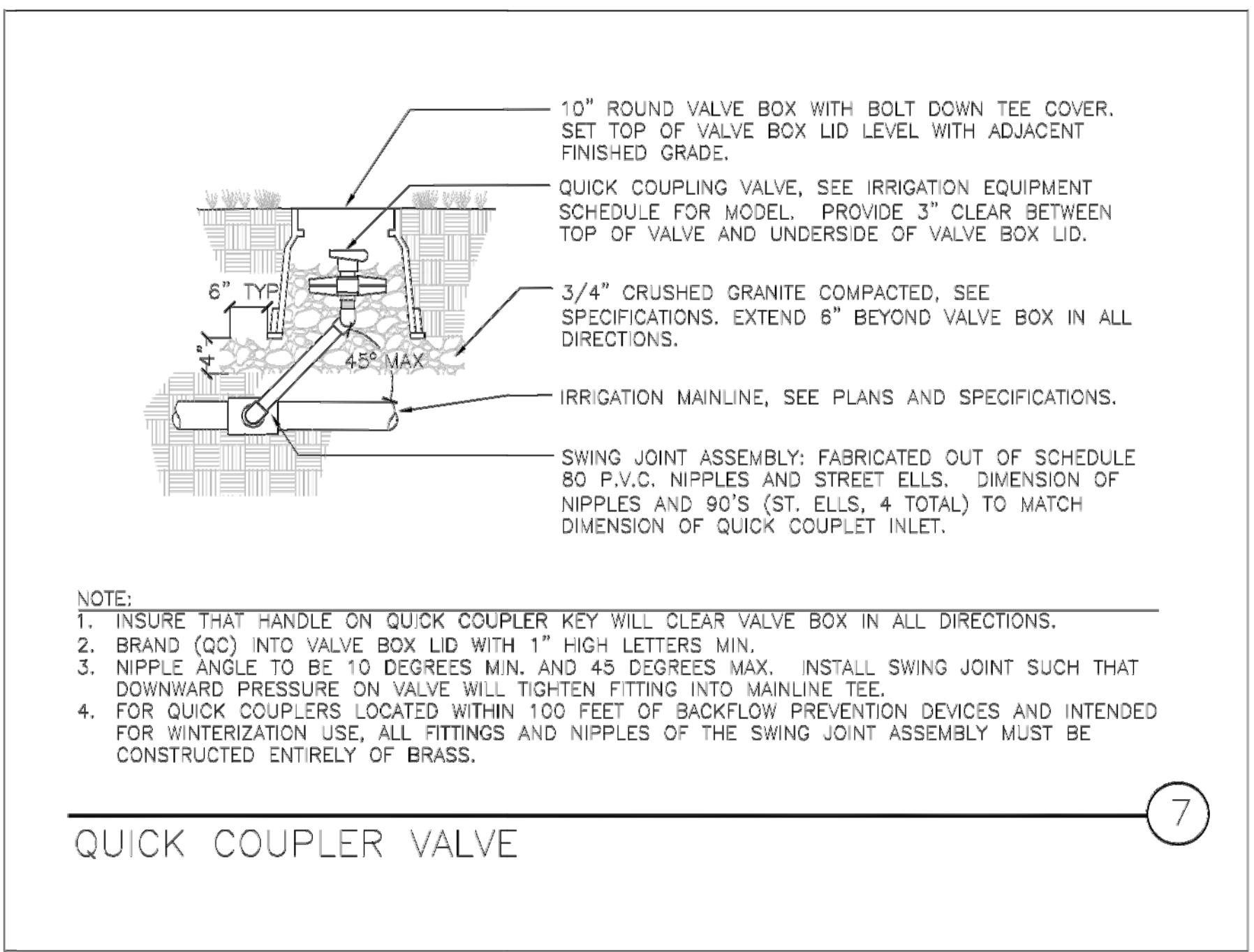
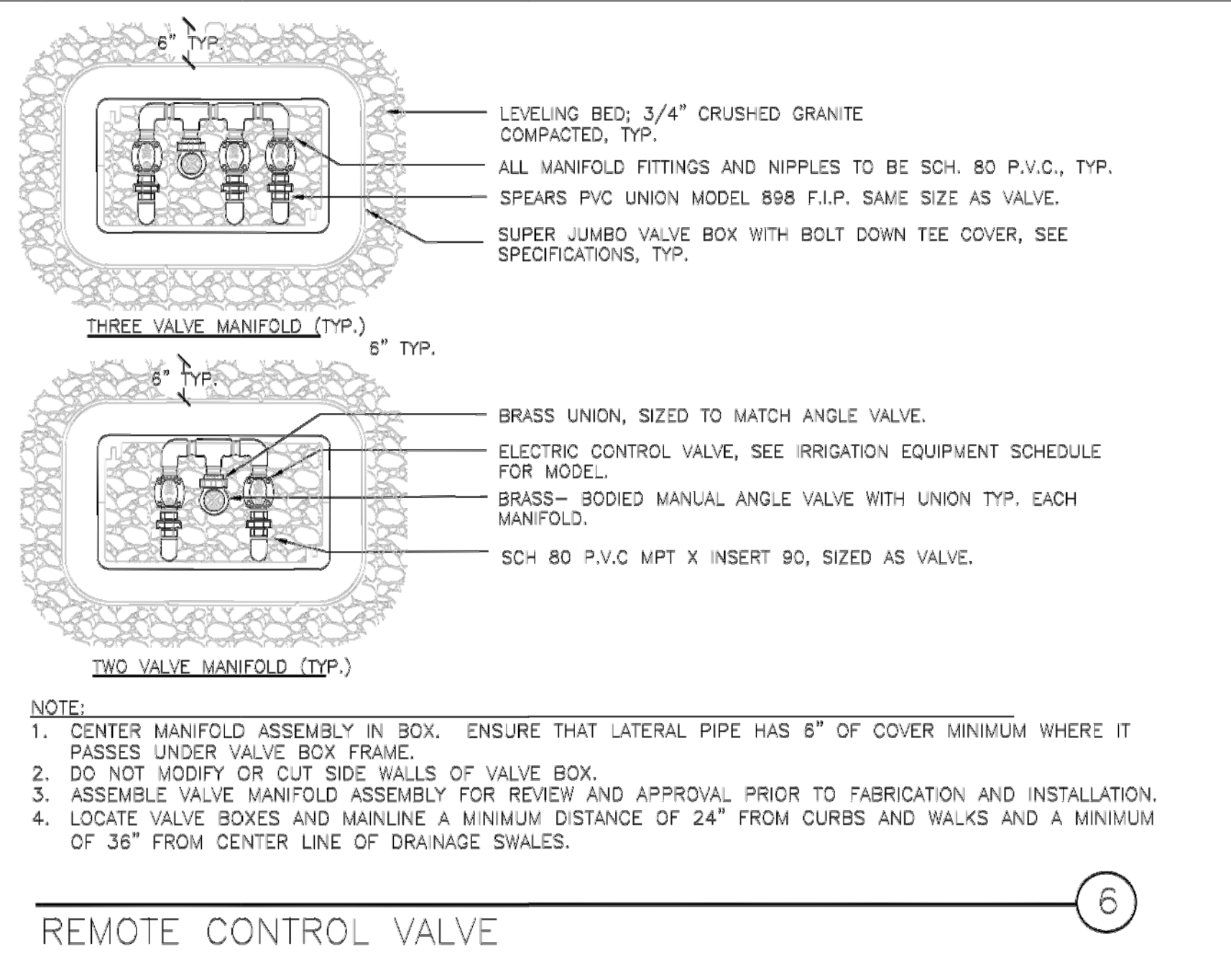

LIST OF IRRIGATION DRAWINGS

24	SHEET INDEX & NOTES
25	IRRIGATION PLAN
26	IRRIGATION PLAN & DETAILS
27-28	IRRIGATION DETAILS
29	IRRIGATION CHARTS
30-31	DENVER WATER INFORMATION

SHEET NUMBERING ON LANDSCAPE AND IRRIGATION PLANS FROM ORIGINAL BID SET. ACTUAL SHEET NUMBER = SHEET NUMBER + 1. TOTAL NUMBER OF SHEETS = 32.



Know what's below. Call before you dig. CALL 1 BUSINESS DAY IN ADVANCE BEFORE YOU DIG, GRADE OR EXCAVATE FOR THE MARKING OF UNDERGROUND MEMBER UTILITIES.

HydroSystems-KDI, Inc.
 860 Tabor Street, Suite 200
 Lakewood, Colorado 80403
 303-980-5327
 303-980-5384 (fax)

NO.	DESCRIPTION OF REVISIONS	DATE	BY

CALL UNCC
 TWO WORKING DAYS
 BEFORE YOU DIG
 1-800-922-1987
 UTILITY INFORMATION CENTER OF
 COLORADO

CITY AND COUNTY OF DENVER
 DEPARTMENT OF PUBLIC WORKS
 ENGINEERING DIVISION
 CAPITAL PROJECTS MANAGEMENT
 2000 W. 3RD AVE. DENVER, CO 80223
 TEL.: (303) 446-3617 FAX: (303) 446-3647

HAMPDEN HEIGHTS STORM SEWER IMPROVEMENTS - PHASE III
E. GIRARD AVE. OUTFALL
 PCO CONTROL NO:
 PILAR REVIEW NO:
 IRRIGATION PLAN

DRAWN BY:	AMC
DESIGNED BY:	AMC
APPROVED:	KJD
DRAWING NAME:	5234-HHS-Pond-IRR-CD-DPR Set.dwg
DATE:	12/11/14
SHEET NO.:	27 of 31

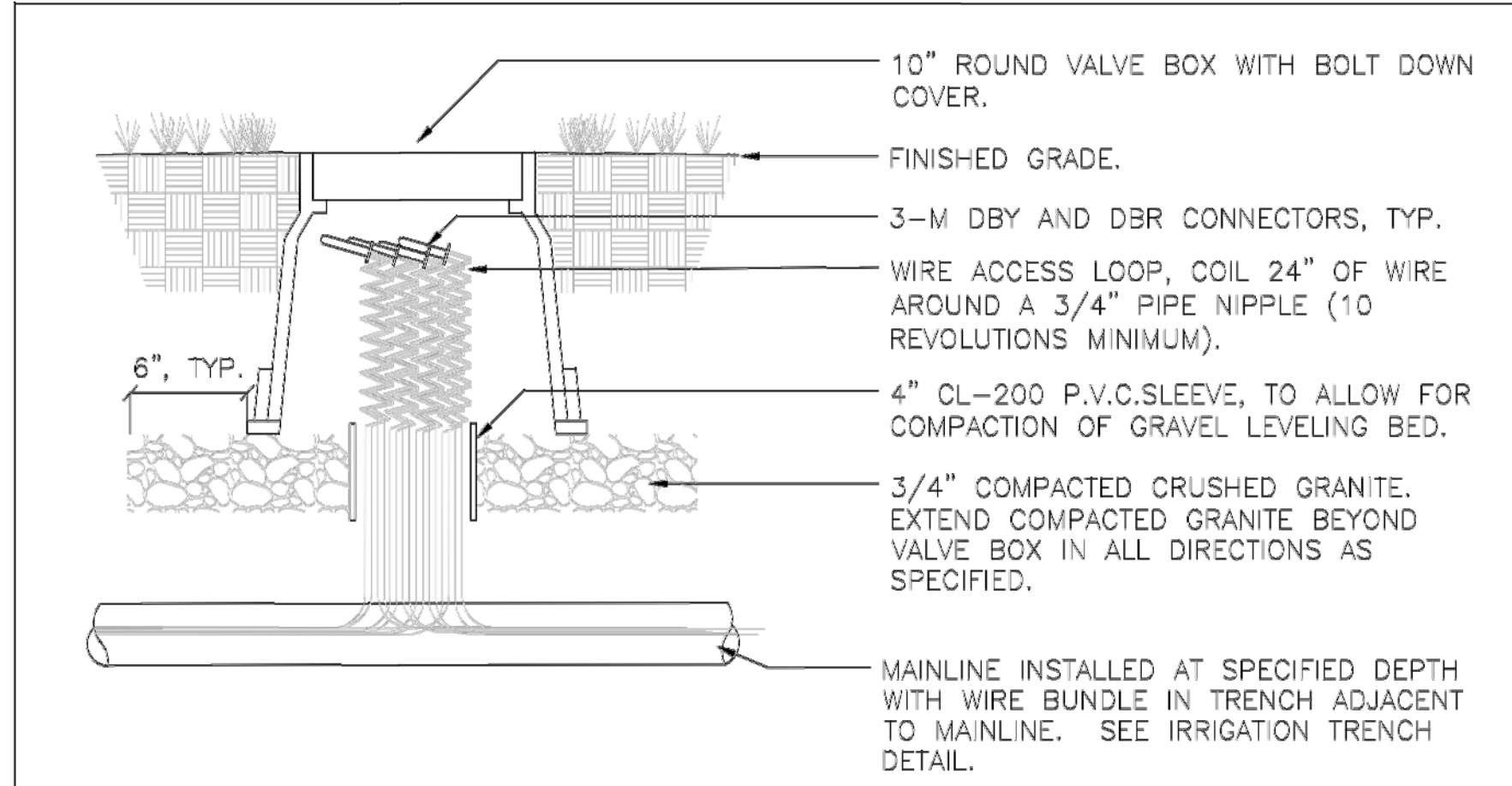

- NOTE:
1. SET TOP OF BOX LEVEL WITH FINISHED GRADE IN TURF AREAS AND LEVEL WITH TOP OF MULCH IN PLANTING BEDS.
 2. USE STANDARD RECTANGULAR VALVE BOX WITH BOLT DOWN LID FOR SPLICES OF MORE THAN TWENTY (20) WIRES.

WIRE SPLICE

19

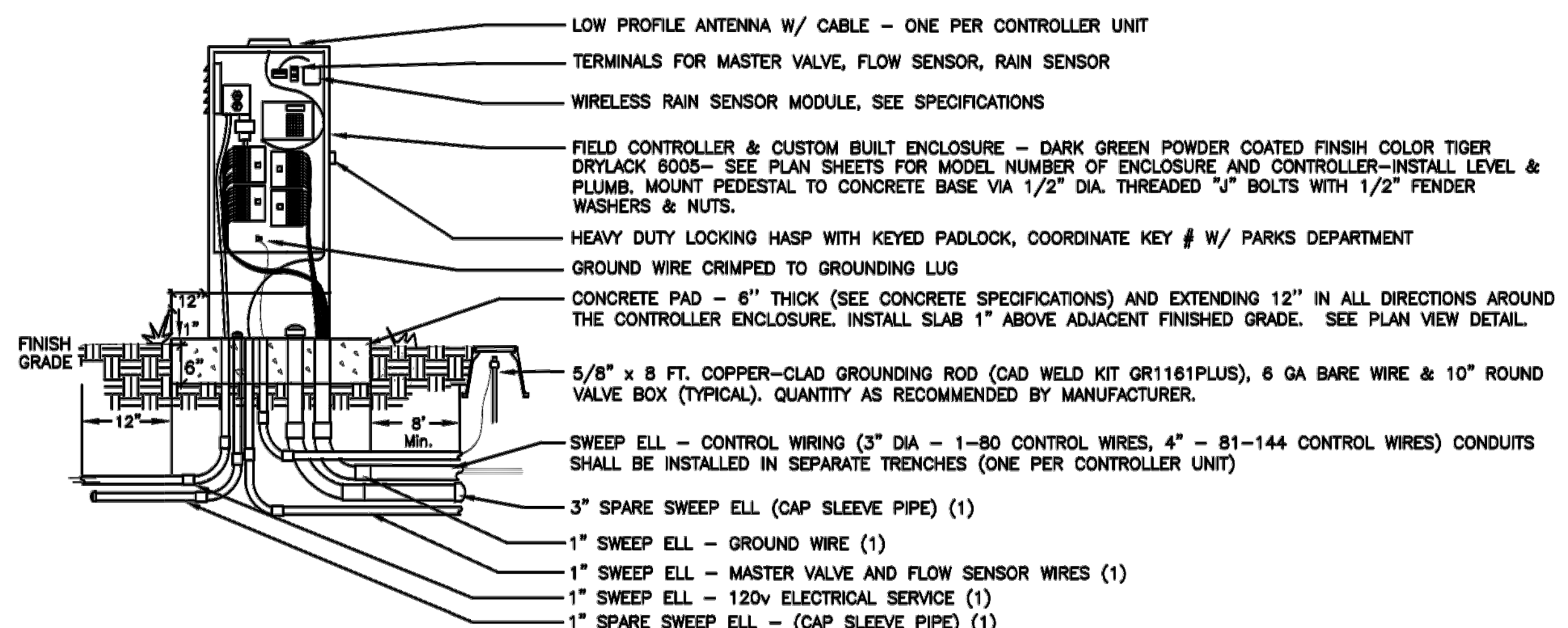

GENERAL NOTES AND REQUIREMENTS

1. 450 MHZ RADIO COMMUNICATION SYSTEM SHALL BE FULLY COMPATIBLE WITH EXISTING DENVER DEPARTMENT OF PARKS AND RECREATION CENTRAL CONTROL UNIT RADIO FREQUENCY.
2. FLOW SENSOR SHIELDED CABLE (PAIGE 7171D-A) SHALL BE CONNECTED TO FLOW SENSOR TERMINAL AT TOP OF CONTROLLER.
3. MASTER VALVE WIRE SHALL BE CONNECTED TO THE MASTER VALVE TERMINAL AT THE TOP OF THE CONTROLLER.
4. ALL WIRE CONDUITS SHALL BE SCH. 40 PVC CONDUIT AND SHALL EXTEND A MINIMUM OF 12" BEYOND THE CONCRETE SLAB AND CUT FLUSH WITH CONCRETE PAD.
5. CONTRACTOR SHALL PROVIDE 48" LENGTH OF SPARE WIRES WITHIN ENCLOSURE. NEATLY COIL WIRES AT BASE OF ENCLOSURE. BUNDLE AND LABEL WIRES ACCORDING TO CONTROLLER DESIGNATION SHOWN ON PLANS.
6. LOCATE CONTROLLER ENCLOSURE SO THAT IRRIGATION HEADS DO NOT SPRAY INTO CABINET.
7. CONTRACTOR SHALL ARRANGE AND PAY FOR A SITE SURVEY FOR ANTENNA SET-UP FOR MAXIMUM SIGNAL QUALITY FOR EACH CONTROLLER SITE AND OPTIMIZATION OF CENTRAL CONTROL COMMUNICATION AFTER INSTALLATION. CONTACT BRANDON GULLY AT CPS (303) 961-6959). SURVEY TO BE CONDUCTED PRIOR TO CONSTRUCTION AND ORDERING OF EQUIPMENT AND IN SUMMER TIME DURING FULL TREE LEAF OUT.

ELECTRICAL AND GROUNDING NOTES:

1. CONTRACTOR TO GROUND AND PROVIDE SURGE PROTECTION FOR FIELD UNIT IN ACCORDANCE WITH MANUFACTURER'S RECOMMENDATIONS AND GROUND ROD(S) SHOWN. 6 GA. (MIN) BARE COPPER GROUND WIRE SHALL BE CONNECTED AND CRIMPED TO STUDS ON THE BACKSIDE OF THE PANEL.
2. CONTROLLER(S) SHALL BE EARTH GROUND TESTED VIA MEGGER WITH ACCEPTABLE GROUND RESISTANCE OF 10 OHMS OR LESS. CONTRACTOR SHALL PERFORM GROUNDING TEST IN PRESENCE OF DENVER PARKS & RECREATION REPRESENTATIVE OR CONSULTANT.
3. EARTH GROUND MUST BE IN ACCORDANCE WITH ARTICLE 250 OF THE NATIONAL ELECTRICAL CODE (NEC).
4. ALL ELECTRICAL WORK TO CONFORM TO LOCAL AND STATE CODES.

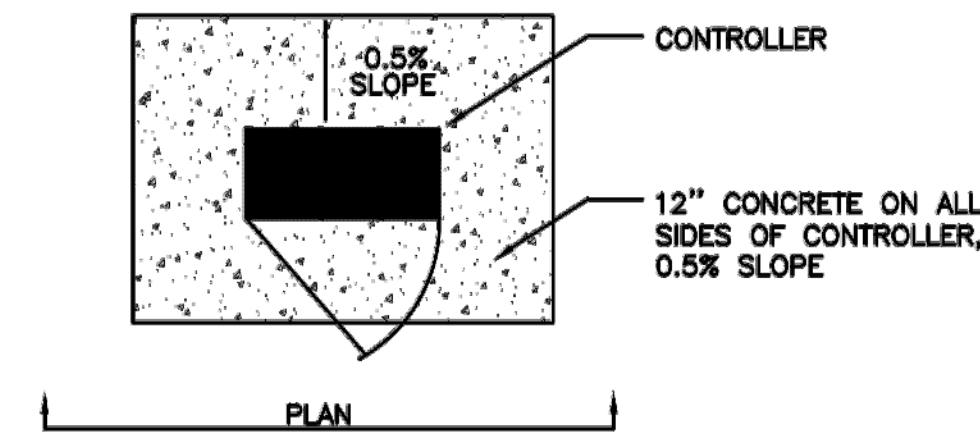

CONTROLLER - SINGLE DOOR

Rev. 5/2/13

20

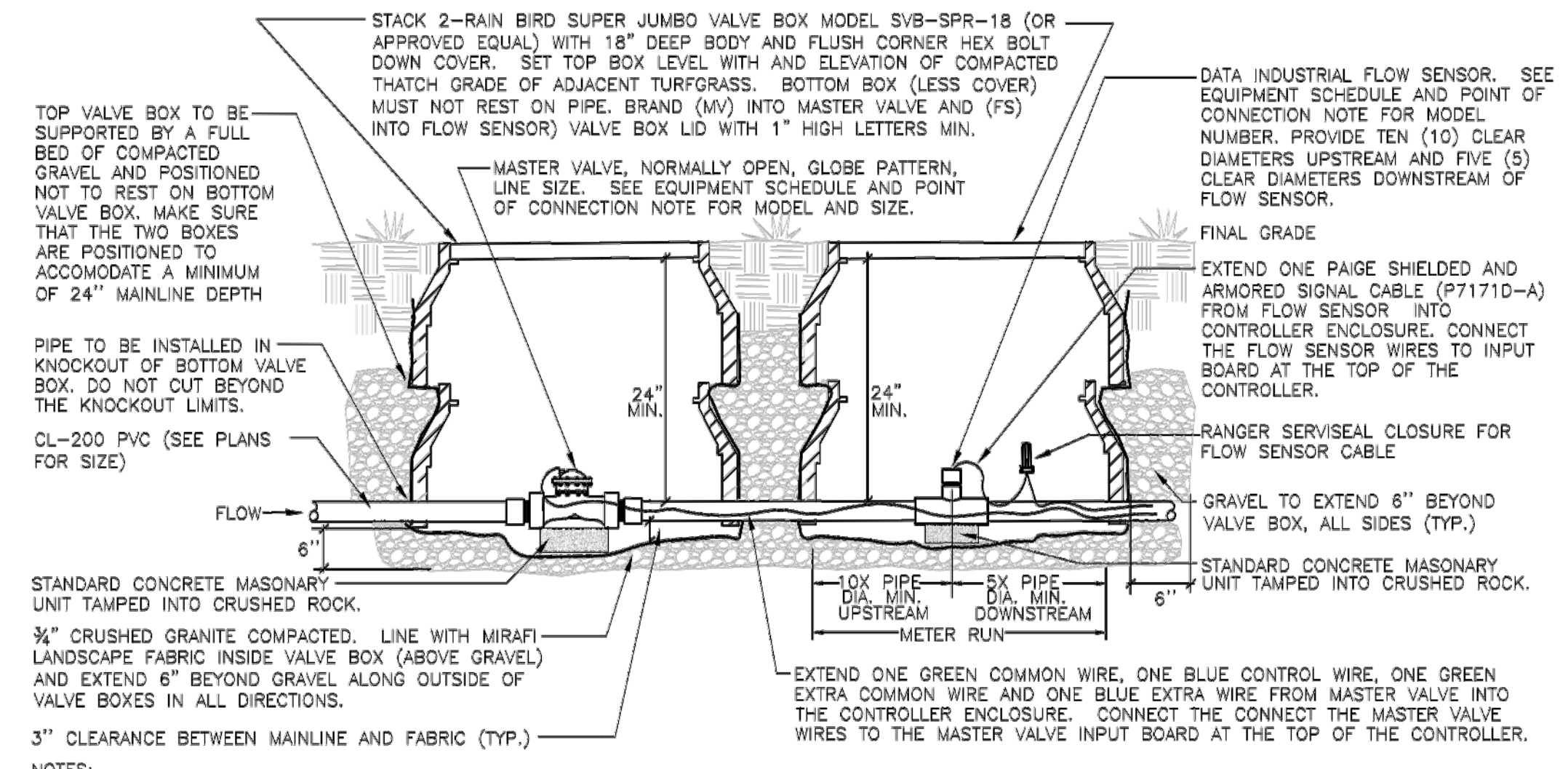

- NOTES:
1. DOWNSTREAM OF THIS ASSEMBLY THE MAINLINE DEPTH WILL REMAIN AT 24" IF IN A RIGHT OF WAY PROJECT OR GO TO A 30" DEPTH FOR PROJECTS WITHIN PARKS, USING 45 DEGREE FITTINGS.
 2. QUICK COUPLER FOR WINTERIZATION MUST BE LOCATED DOWNSTREAM OF THIS ASSEMBLY.

MASTER VALVE/FLOW SENSOR- MAINLINE 2-1/2" & SMALLER

Rev. 08/19/13 21

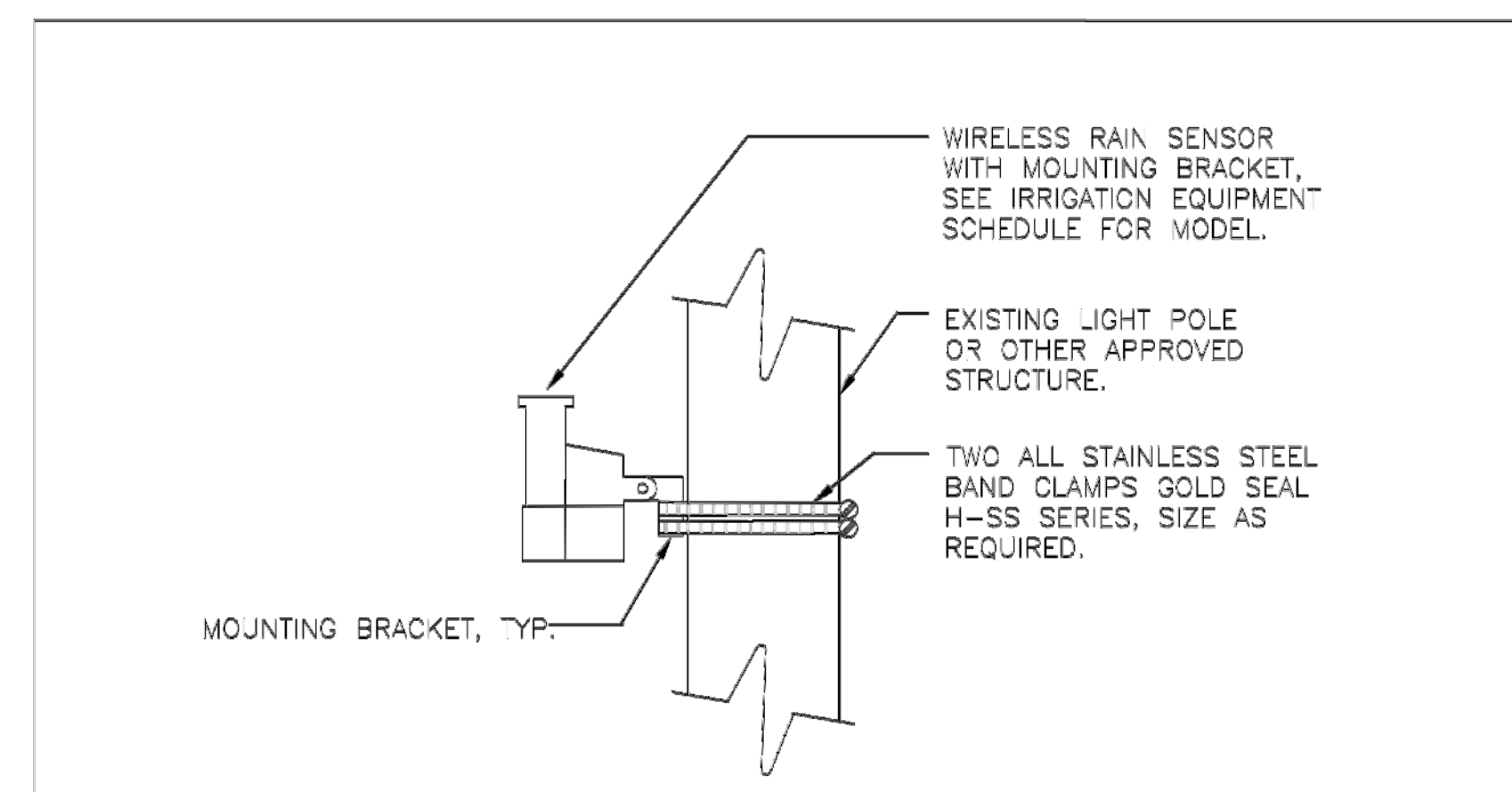

- NOTE:
1. MOUNT TO POLE OR LIGHT POLE WITHIN 200 FEET OF CONTROLLER.
 2. INSTALL A MINIMUM OF 15' ABOVE GRADE.
 3. ENSURE SENSOR IS NOT SHIELDED BY TREE CANOPIES OR STRUCTURES AND NOT AFFECTED BY IRRIGATION OVERSPRAY.

RAIN SENSOR

24

BFP MODEL/SIZE	ENCLOSURE MODEL	X	Y
FEBCO 825Y 3/4" & 1"	SBBC-30AL	30"	42"
FEBCO 825Y 1 1/2" & 2"	SBBC-45AL	45"	57"
FEBCO 825YA 3/4" & 1"	SBBC-15AL	15"	27"
FEBCO 825YA 1 1/2" & 2"	SBBC-30AL	30"	42"

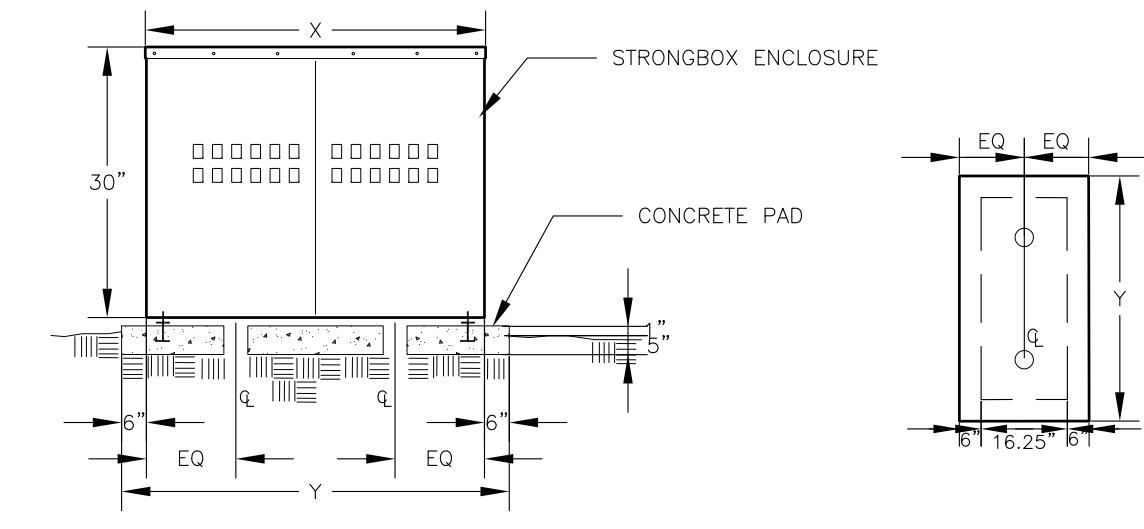

- NOTES:
- PAD PENETRATIONS FOR BACKFLOW PREVENTER RISERS TO BE 1" LARGER THAN RISER DIAMETER.
 - TOP SURFACE OF CONCRETE PAD SHALL BE 1" ABOVE FINISH GRADE.
 - INSTALL ENCLOSURE ANCHORS AS PER MANUFACTURER'S RECOMMENDATIONS.
 - PROVIDE OWNER WITH KEYPAD FOR ENCLOSURE.

BACKFLOW ENCLOSURE

A

LIST OF IRRIGATION DRAWINGS

24	SHEET INDEX & NOTES
25	IRRIGATION PLAN
26	IRRIGATION PLAN & DETAILS
27-28	IRRIGATION DETAILS
29	IRRIGATION CHARTS
30-31	DENVER WATER INFORMATION

NO.	DESCRIPTION OF REVISIONS	DATE	BY

CALL UNCC
TWO WORKING DAYS
BEFORE YOU DIG
1-800-922-1087
UTILITY INFORMATION CENTER OF
COLORADO

CITY AND COUNTY OF DENVER
DEPARTMENT OF PUBLIC WORKS
ENGINEERING DIVISION
CAPITAL PROJECTS MANAGEMENT
2000 W. 3RD AVE. DENVER, CO 80223
TEL.: (303) 446-3617 FAX: (303) 446-3647

HAMPDEN HEIGHTS STORM SEWER
IMPROVEMENTS - PHASE III
E. GIRARD AVE. OUTFALL
PCO CONTROL NO:
PILAR REVIEW NO:
IRRIGATION PLAN

DRAWN BY:	AMC
DESIGNED BY:	AMC
APPROVED BY:	KJD
DRAWING NAME:	5234-HHS-Pond-IRR-CD-DPR Set.dwg
DATE:	12/11/14
SHEET NO.:	28 of 31



Know what's below.
Call before you dig.

HydroSystems-KDI, Inc.
860 Tabor Street, Suite 200
Lakewood, Colorado 80401
303-980-5327
303-980-5384 (fax)

WATER BUDGET									
PROJECT NAME: 5234-Hampden Heights School					SUBMITTED BY HydroSystems*KDI			DATE: 8-Dec-2014	
DESCRIPTION	IRRIGATED ACRES	MONTH	HISTORICAL ET	PLANT COEFFICIENT	PLANT WATER REQUIREMENT	SYSTEM EFFICIENCY (%)	TOTAL WATER REQUIREMENTS (IN.)	WEEKLY WATER REQUIREMENTS (IN.)	MONTHLY WATER REQUIREMENTS (GAL.)
PLANT TYPE:	1.05	APRIL	2.26	0.5	1.13	70%	1.61	0.37	45,717
Native Plant Material (Low Usage)		MAY	5.73	0.5	2.87	70%	4.09	0.94	115,910
		JUNE	6.64	0.5	3.32	70%	4.74	1.09	134,318
		JULY	7.27	0.5	3.64	70%	5.19	1.19	147,062
		AUGUST	5.87	0.5	2.94	70%	4.19	0.96	118,742
		SEPTEMBER	4.45	0.5	2.23	70%	3.18	0.73	90,017
		OCTOBER	1.6	0.5	0.80	70%	1.14	0.26	32,366
OPERATING PERIOD-HRS./DAY	4.6		33.82		16.91	TOTAL	24.16	TOTAL	684,130
DAYS/WEEK	3							ACRE FEET/YR.	2.10
DAYS/MONTH	13							PEAK SEASON GPM	41
MINIMUM REQUIRED SYSTEM EFFICIENCIES: Drip irrigation - 90% Rotor irrigation - 70% Spray head irrigation: 65% April & October ET = 1/2 Monthly Value ET data from Denver Water weather stations (Average 2003-2008)								PROJECT TOTALS	
								IRRIGATED ACRES	1.05
								GALLONS/YEAR	684,130
								ACRE FEET/YEAR	2.10
								PEAK SEASON GPM	41

Project 5234-Hampden Heights School
Location Denver

Controller B - Point of Connection # 1 (1 1/2")
09-Dec-14

Target Watering Window = 6 nights per week - 6 hours per night (36 hours/week)
Estimated weekly application = 2.06" - Bluegrass (High Usage)
Estimated weekly application = 1.96" - Fescue (Moderate Usage)
Estimated weekly application = 1.29" - Shrubs (Moderate Usage)
Estimated weekly application = 1.19" - Native Plant Material (Low Usage) - Establishment Irrigation Only
Prepared by HydroSystems-KDI, Inc.

Zone No.	Plant Type	Zone Description	Precip. Rate in/hr	Zone Flow GPM	Peak Demand In/wk	Zone run time minutes	Water usage gal/wk	Operating Pressure psi
B1	Shrubs	Rotary Spray	13 ft 0.70	36	1.29	24.04	3,981	45.00
B2	Shrubs	Rotary Spray	13 ft 0.70	26	1.29	24.04	2,875	45.00
B3	Shrubs	Rotary Spray	13 ft 0.70	11	1.29	24.04	1,216	45.00
B4	Shrubs	Rotary Spray	13 ft 0.70	37	1.29	24.04	4,091	45.00
B5	Native	Hipop Spray	15 ft 1.83	28	1.19	8.48	1,092	30.00
B6	Native	Rotor	#18 0.96	29	1.19	16.17	2,157	55.00
B7	Native	Rotor	#18 0.96	29	1.19	16.17	2,157	55.00
B8	Native	Hipop Spray	15 ft 1.83	24	1.19	8.48	936	30.00
B9	Native	Rotor	#18 0.96	29	1.19	16.17	2,157	55.00
B10	Native	Rotor	#18 0.96	29	1.19	16.17	2,157	55.00
B11	Native	Hipop Spray	15 ft 1.83	34	1.19	8.48	1,327	30.00
B12	Native	Rotor	#18 0.48	15	1.19	32.34	2,231	55.00
B13	Native	Rotor	#18 0.96	29	1.19	16.17	2,157	55.00
B14	Native	Rotor	#18 0.96	29	1.19	16.17	2,157	55.00
B15	Native	Hipop Spray	15 ft 1.83	20	1.19	8.48	780	30.00
B16	Native	Rotor	#18 0.96	29	1.19	16.17	2,157	55.00
B17	Native	Rotor	#18 0.96	29	1.19	16.17	2,157	55.00
B18	Native	Rotor	#18 0.96	29	1.19	16.17	2,157	55.00
B19	Native	Rotor	#18 0.96	29	1.19	16.17	2,157	55.00
B20	Native	Rotor	#18 0.96	29	1.19	16.17	2,157	55.00
B21-B24	Spare							
Total projected peak season water use per week (gallons)							42,255	
Total peak season hours per week - Controller B								
							Native Establishment:	24.41
							After Establishment:	9.61

(Rotary Sprays on Trees and Shrubs shall not operate during Native Establishment.)

- LIST OF IRRIGATION DRAWINGS
- 24 SHEET INDEX & NOTES
 - 25 IRRIGATION PLAN
 - 26 IRRIGATION PLAN & DETAILS
 - 27-28 IRRIGATION DETAILS
 - 29 IRRIGATION CHARTS
 - 30-31 DENVER WATER INFORMATION

Project Name: 5234-Hampden Heights School
Project Location: Denver

Irrigation System Hydraulic Worksheet
Prepared by HydroSystems-KDI, Inc.

Date: 28-Oct-13
Static Water Pressure: 108.00 **From:** Arnie Strauss
of DW Hydraulics

Equipment or Material	Quantity (one if not specified)	Nominal Size	Equipment or Pipe Material	Friction Loss Through Pipe per Chart (psi)	Velocity through pipes (ft/sec)	Flow Rate (gpm)	Loss/Gain (psi)
Corp Stop:		1 1/2"	Typical Corp. Stop			41	0.70
Svc Line (tap to meter):	30 LF	1 1/2"	K Copper	7.26 /100 FT	7.81	41	2.18
Curb Stop:		1 1/2"	Typical Curb Stop			41	0.40
Water Meter:		1 1/2"	Typical Meter			41	3.60
Svc Line (meter to backflow):	25 LF	1 1/2"	K Copper	7.26 /100 FT	7.81	41	1.82
Backflow:		1 1/2"	Febco 825YA			41	12.50
Stop & Waste:		1 1/2"	Typical Stop & Waste Valve			41	0.50
Master Valve:		1 1/2"	Bernad 710			41	0.72
Flow Sensor:		1 1/2"	Data Industrial			41	0.50
Gate Valve:	1	2"	Typical Bronze Gate Valve			41	0.04
Gate Valve:	3	2"	Typical Bronze Gate Valve			41	0.12
Gate Valve:	1	2"	Typical Bronze Gate Valve			41	0.04
Pressure Required at Head:			Rotors				55.00
Lateral Allowance:							3.00
Control Valve allowance:			2" Rainbird PEB			41	4.80
Mainline allowances:							
	30 LF	2"	CL 200 PVC	1.04 /100 FT	3.71	41	0.31
	2210 LF Looped	2"	CL 200 PVC	0.32 /100 FT	1.94	41	7.07
	200 LF	2"	CL 200 PVC	1.04 /100 FT	3.71	41	2.08
Mainline Fitting allowance:			10% of Mainline allowances				0.95
Elevation:							
Tap Elev.	5484		Control Valve Elev.	5480			-1.73
Factor of Safety:			5% System Losses				4.73
Total System requirements (PSI)							99.32
Available pressure (PSI)							108.00
Difference (PSI)							8.68

HYDROZONE MAP



LOW WATER USE - NATIVE SEED

AFTER ESTABLISHMENT OF NATIVE SEED, ZONES FOR NATIVE SHALL BE SHUT DOWN AT WHICH TIME TREES AND SHRUBS ZONES SHALL BE TURNED ON. ALL PLANT MATERIAL IS LOW WATER USE.

SHEET NUMBERING ON LANDSCAPE AND IRRIGATION PLANS FROM ORIGINAL BID SET. ACTUAL SHEET NUMBER = SHEET NUMBER + 1. TOTAL NUMBER OF SHEETS = 32.



Know what's below.
Call before you dig.

HydroSystems-KDI, Inc.
860 Tabor Street, Suite 200
Lakewood, Colorado 80401
303-980-5327
303-980-5384 (fax)

NO.	DESCRIPTION OF REVISIONS	DATE	BY

CALL UNCC
TWO WORKING DAYS
BEFORE YOU DIG
1-800-922-1987
UTILITY INFORMATION CENTER OF
COLORADO

CITY AND COUNTY OF DENVER
DEPARTMENT OF PUBLIC WORKS
ENGINEERING DIVISION
CAPITAL PROJECTS MANAGEMENT
2000 W. 3RD AVE. DENVER, CO 80223
TEL.: (303) 446-3617 FAX: (303) 446-3647

HAMPDEN HEIGHTS STORM SEWER
IMPROVEMENTS - PHASE III
E. GIRARD AVE. OUTFALL
PCO CONTROL NO:
PILAR REVIEW NO:
IRRIGATION PLAN

DRAWN BY:	AMC
DESIGNED BY:	AMC
APPROVED BY:	KJD
DRAWING NAME:	5234-HHS-Pond-IRR-CD-DPR Set.dwg
DATE:	12/11/14
SHEET NO.:	29 of 31

PLOT DATE: December 17, 2014
C:\DATA\DWG\DWG-AMBER\3234-HAMPDEN HEIGHTS SCHOOL POND PACKAGE\5234-HHS-POND-IRR-CD-DPR-SET.DWG

Revision Date: November 14, 2013

General Construction and Water Notes:

Main Extension Notes:

- All materials and workmanship shall be in conformance with Denver Water's Engineering Standards, Materials Specifications, and Drawings. All main installations/system modifications will be approved and inspected by Denver Water.
- Contractors shall maintain a copy of the current Engineering Standards on-site at all times during construction. See the chart below for a quick reference to the frequently used material specifications.

Material Specification Quick References:

Material Specification	Description
MS 01	DI Pipe
MS 02	PVC Pipe
MS 03	Fittings
MS 4, MS 6	Valves
MS 8	Tapping Valves
MS 9	Tapping Sleeves
MS 12	Valve Boxes (Recycled water system valve boxes shall be fitted with triangular covers cast with the words "Denver Water Recycles" and shall be coated with a fusion bonded epoxy coating, pantone 2577U in color.)
MS 13	Dry Barrel Fire Hydrants
MS 23	Brass and Bronze Goods
MS 29	Restraint Device

- Tracer wire, 12 gauge, shall be installed on all non-metallic water mains.
- For all pipe installations, the depth of cover over the pipe, measured from official street grade to the top of the pipe, shall be a minimum of 4-1/2 feet and shall be

Revision Date: November 14, 2013

- known as the cover over the pipe. If difficulties arise when crossing interference, and where specifically approved by Denver Water, deviations from 4-1/2 feet of cover will be permitted. The cover over the pipe shall be a minimum of 4-1/2 feet and a maximum of 10 feet. Refer to Standard Drawing Sheet 16.
- Any changes in alignment and grade shall be authorized by Denver Water and shall be accomplished by the installation of additional fittings. The deflection of joints is permitted only when installing pipe on horizontal or vertical curves.
 - The Contractor shall adjust all valve boxes and fire hydrants to the final finished grade.
 - All bends, tees, fire hydrants, blow-offs, and plugs at dead-end mains shall be protected from thrust with mechanical restraint and concrete thrust blocks in accordance with Denver Water's Engineering Standard Drawings Sheet 28 and 32.
 - All valves are to be located on property line extensions, except for tapping tees where an additional valve shall be placed on the tapping tee. Other valve locations may be required as shown on the plans.
 - When it is necessary to lower or raise water lines at storm drains and other utility crossings, a minimum clearance of 1.5 feet shall be maintained between the outside of the pipes.
 - The Contractor shall have one signed copy of the approved water plans in his/her possession at all times.
 - Only one point of connection will be allowed until the testing of the new installations is complete.
 - Newly installed water mains and firelines shall be hydrostatically tested in accordance with Denver Water Engineering Standards, Section 9.25.
 - Prior to the installation of water mains, road construction must have progressed to at least the sub-grade state. Sub-grade is defined as an elevation of no more than 7 inches below the finished street grade.
 - The Contractor is responsible for:
 - Notifying customers who may be affected by a water outage during construction.
 - Obtaining, at the Contractor's expense, applicable licenses, permits, bonds, etc. that are required for the main installation/system modification.
 - Contact Denver Water's Construction Engineering personnel for the Pre-construction Meeting and Inspection, 303-628-6038, at least 48 hours prior to beginning construction. In the event of an emergency in Denver or in a Total Service Area after working hours, call Denver Water's Westside Dispatcher: 303-628-6390. In a Master Meter District, please contact the representative of the District in which the Project is taking place.
 - Paying all additional charges for inspection outside normal work hours.

Note: Be advised that on occasion valves in our system may be inoperable. On such occasions, it may become necessary to back up an additional block for the shut out. If that occurs, make additional notifications to customers with the mandatory 24 hours advance notice. When valve maintenance is required, a delay of several days should be expected.

Revision Date: November 14, 2013

Tap and Meter Notes (for Denver, Total Service, and Read and Bill Areas only. In Master Meter Districts, please refer to the Specification for that District).

- Before any taps are made from mains, application(s) for the taps must be received and approved by the Distributor and by Denver Water.
- Denver Water will make all taps that are 2 inches and smaller.
- Individual service line PRVs are required when area pressure exceeds 80 psi.
- Services and Meters:
 - The Contractor shall hold an on-site pre-construction conference with the Meter Inspector for all taps, service lines, and meters larger than one inch, and for projects involving more than one tap and service. To schedule a pre-construction conference call 303-628-6145.
 - A copy of these plans with Denver Water's approval sticker must be present on-site at the time the tap is made and at the time the meter is inspected or installed.
 - Prior to the tap being made, the service address shall be posted, along with the curb valve, meter yoke, and meter pit/vault installed. Upon tap installation, the contractor may request the Meter Inspection after the first pour of concrete has occurred. The service address shall remain posted until the meter setting passes inspection.
 - A Soil Amendment inspection will be required prior to the completion of the Certificate of Occupancy. Contact Conservation at 303-628-6670 for information and to schedule a soil amendment inspection.
 - Meters cannot be set or inspected, or services activated, until the requirements for backflow prevention have been completed. Contact the Backflow Prevention Program personnel at 303-628-5940 for further information.
 - Allow at least 3 working days advance notice when scheduling taps. To schedule a tap call 303-628-6701; for questions related to a meter inspection call 303-628-6145. Service activation will take place when the service and meter setting pass inspection.
 - All meter and Automatic Meter Reading device locations shall be approved by a Denver Water meter inspector, except in Master Meter Distributor Districts.
 - Meter pits and vaults must be set flush with the final grade of the landscape, including proper depth of soil amendment. If final grading has not been completed at the time of meter inspection, the Owner will be required to raise or lower the meter pit/vault when final grade is established. Adjustment of the pit may require adjustment of the meter setting within the pit.
 - Meter setting, valves, and service lines from the main to the Backflow Preventer Assembly, if present, or to 5 feet after the meter vault, must meet all applicable Engineering Standards in effect at the time of activation. If necessary to comply with current standards, modifications may be required from the details on these plans.
 - No present or future fences or walls are permitted between the Right Of Way (ROW) or easement and the meter setting. There shall be no permanent obstructions within 5 feet of the outside wall of the meter pit or vault.

Revision Date: November 14, 2013

- Tap relocation (from what is shown on these plans) may be necessary to avoid paved areas or other obstructions that are not shown on the plans. Deviations from these plans and standards must be approved prior to construction.
 - Inside the City of Denver and in Total Service and Read & Bill Distributor Districts, meters must be furnished with Automatic Meter Reading (AMR) devices as specified by Denver Water. The AMR devices will be installed by Denver Water at the time of service activation.
 - Meter pits and vaults shall have appropriate lids based on the location and the application. Contact Meter Inspection at 303-628-6145 to determine the correct lid configuration.
 - The Contractor shall provide a remote AMR device mounting box when required. Install a double-gang 4x4 electrical junction box; mount as directed 7 feet above grade. Install Belden #9451 cable in 3/4-inch or larger conduit from the meter to the mounting box. Two boxes and two cables are required for compound meters.
 - Inside the City of Denver, all multi-family dwellings with a single tap, service line, and meter are required to sub-meter each individual unit (Sec 401.3.2 of Denver modifications to the International Plumbing Code, Ordinance Number 576, Series of 2004). Call the City and County of Denver Plumbing Inspector for information at 720-865-2625.
 - Inside the City of Denver, all service lines must be installed to avoid existing or proposed street trees. Contact the City and County of Denver's Forester at 720-913-0547 for information.
 - Existing services must be metered at all times until the tap has been cut at the main and witnessed by Denver Water.

Cross-Connection Control Requirements:

The licensee listed below shall be in conformance with Denver Water's Engineering Standards, Chapter 5.05, *Cross-Connection Control and Backflow Prevention*. Backflow prevention assemblies are required to be installed on the following water service lines:

- Commercial Properties:** Real estate zoned for businesses and/or industrial use that consist of six or more units with a domestic, fireline, or dedicated water irrigation service tap (defined as such for cross-connection purposes).
 - Domestic, dedicated irrigation, fireline and/or recycled water service lines.
- Multi-Family Residential:** A dwelling with two to five units with a domestic, fireline, and/or dedicated water service tap (defined as such for cross-connection purposes).
 - Premises over three stories/greater than 30 feet, fire protection systems, common boiler, auxiliary water, swimming pool and irrigation systems.
- Single Family Residential:** A single unit dwelling (defined as such for cross-connection purposes).
 - Dual Water Supply Agreement.

Revision Date: November 14, 2013

- All backflow prevention assemblies shall be a model manufactured in compliance with AWWA C510 and C511 and shall have met the specifications by the University of California Foundation for Cross-Connection Control and Hydraulic Research:

Foundation for Cross-Connection Control and Hydraulic Research
School of Engineering MC-2531
University of Southern California
P.O. Box 77902
Los Angeles, CA 90007
Foundation Office: (866) 545-6340
<http://www.usc.edu/dept/fccchr/>

The licensee is required to have a certified American Backflow Prevention Association (ABPA) or American Society of Sanitary Engineering (ASSE) tester inspect and test the existing and/or newly installed containment backflow prevention assemblies on the dedicated water service lines (domestic, dedicated irrigation, fireline, and recycled) upon installation and annually thereafter.

- The ABPA or ASSE certified backflow tester is responsible to meet the requirements listed in the Engineering Standards, Chapter 5.05.
 - If the ABPA or ASSE certified backflow tester is testing a backflow prevention assembly installed on a recycled water service line, the tester is required to have a dedicated recycled water test gauge.

- Within 48 hours of Denver Water setting the meter and turning on the water service, the ABPA or ASSE certified backflow tester is required to submit the containment backflow assembly test report(s) to the Cross-Connection Control Office:

Phone: 303-628-5969
Fax: 303-794-8325
E-mail: CrossConnectionControl@denverwater.org
Mailing Address: Denver Water
Attn: Cross-Connection Control
6100 W. Quincy Avenue
Denver, CO 80235

There shall be no unprotected takeoffs from the service line ahead of any meter or ahead of a backflow prevention assembly located at the point of delivery to the customer's water system.

- No branch lines or taps are allowed on dedicated commercial irrigation water service lines or recycled water service lines for domestic (potable) use (e.g., drinking fountains, water play features, swimming pool, restroom facilities, etc.):
 - Between the irrigation tap and the meter.
 - Between the meter and the backflow prevention assembly.
 - Downstream from the backflow prevention assembly.

Revision Date: November 14, 2013

4. Commercial Irrigation Water Service Line Taps:

- Comply with the Cross-Connection Control requirements listed above (A-F).
- Require an approved USC FCCCHR Reduced Pressure Principle (RP) backflow prevention assembly to be installed 5 feet downstream from the meter pit as an above ground installation before any connections. Refer to the manufacturer's installation instructions for height and orientation requirements.
 - If the backflow prevention assembly cannot be installed 5 feet downstream from the meter pit, include a variance letter justifying the need for relocation.

5. Recycled Water Service Lines Taps:

- Backflow prevention assemblies are required to be installed on commercial recycled water service line taps:
- If chemical injection is used downstream from the meter.
 - If pumps are used downstream from the meter.
 - If the existing or proposed system poses a risk to the integrity of the recycled water system.
 - Comply with the Cross-Connection Control requirements listed above (A-F).
 - Require an approved USC FCCCHR Reduced Pressure Principle (RP) backflow prevention assembly to be installed 5 feet downstream from the meter pit as an above ground installation before any connections. Refer to the manufacturer's installation instructions for height and orientation requirements.
 - If the backflow prevention assembly cannot be installed 5 feet downstream from the meter pit, include a variance letter justifying the need for relocation.
 - Backflow prevention assemblies installed on recycled water service lines shall be identified as "Recycled Water."

6. Recycled or Raw Water (ditch water, pond, well, etc.) used for irrigation on the premises:

- Comply with the Cross-Connection Control requirements listed above (A-F).
- Require an approved USC FCCCHR backflow prevention assembly (containment) to be installed 5 feet downstream from the meter pit on any potable water service line.
 - The backflow assembly type is determined by the Degree of Hazard downstream from the meter; refer to Denver Water's Engineering Standards, 1.05, Degree of Hazard, or contact Cross-Connection Control at 303-628-5940.

- It is at the sole discretion of Denver Water's Cross-Connection Control section to approve a variance request related to a proposed backflow prevention assembly installation.

Revision Date: November 14, 2013

Health Notes/Water Quality:

- The Colorado Department of Public Health & Environment (CDPHE) regulates asbestos activities through the Air Pollution Control Division (APCD) and the Solid Waste and Materials Management Division (SWMDM) when soil contamination is involved. Denver Water will require contractors and developers to follow the procedures below when cement asbestos pipe is encountered:
 - The pipe must be removed from the excavation for proper disposal.
 - The Contractor/Developer will manage the pipe in accordance with the following regulations:
 - Colorado Air Regulations No 8 – Control of Hazardous Air Pollutants
 - OSHA 29 CFR 1910.1001 – General Industry Standards – Asbestos
 - OSHA 29 CFR 1926.1101 – Construction Standards – Asbestos
 - If large amounts of cement asbestos pipe are anticipated to be removed, the material must be managed by an appropriate asbestos abatement contractor (100 square feet or 260 linear feet will require a permit).
- Note: Cement Asbestos Pipe is considered a non-friable asbestos material, defined as containing more than 1% asbestos by weight, and cannot be crumbled, pulverized, or reduced to powder by hand pressure. Therefore, a release of asbestos fibers is not likely during normal use and handling of this material.*

- Denver Water personnel are not responsible for work site safety or the compliance/enforcement of safety regulations and standards established by other agencies. All safety compliance/enforcement at the work site shall be the Contractor's sole responsibility.
- The Water Quality Control Division of The Colorado Department of Public Health and Environment (CDPHE) requires all water line contractors to possess a current Discharge Permit for discharges of chlorinated and process waters associated with the installation of new mains or conduits. Contact CDPHE Water Quality Control Division at 303-892-3539 for information on obtaining the required permit.
- Chlorination and Flushing: All water mains shall be installed and chlorinated in accordance with Denver Water's Engineering Standards, Section 8.24. The lines shall be chlorinated in accordance with AWWA C-651, "Disinfecting Water Mains." The preferred method is to use sufficient chlorine tablets to produce a 25 mg/l solution. Tablets should be attached to the top of the pipe with an approved adhesive certified to NSF Standard 61, prior to pipe installation in the trench. Chlorination of 16 inch and larger pipe requires a chlorine slurry. The chlorination of any finished pipeline shall be completed prior to hydrostatic testing.

Irrigation Notes:

- Irrigation of medians and other public landscaped areas less than 25 feet in width must be done in accordance with Denver Water Operating Rule 14.02.3. (Call DW Conservation Section at 303-628-6343 for information regarding irrigation systems.)

Revision Date: November 14, 2013

- For strips of land less than 6 feet in width – Spray irrigation shall be prohibited. Low-flow irrigation systems are required.
 - For strips of land between 6 feet and 15 feet in width – Only low flow irrigation, or spray irrigation using low-angle spray nozzles designed for the specific width to be irrigated shall be permitted. All spray heads must be pressure reducing and designed to prevent low head drainage.
 - For strips of land more than 15 feet in width – Only gear-driven rotors with low angle nozzles may be used to irrigate turf areas. Planting beds may be irrigated with low-flow or spray irrigation. All spray heads must be pressure reducing and designed to prevent low head drainage.
- Irrigation service lines require an approved University of Southern California (USC) Reduced Pressure Principle (RP) backflow prevention assembly (containment) to be installed 5 feet downstream from the meter pit as an above ground installation before any connections. Refer to the manufacturer's installation instructions for height and orientation requirements.
 - If recycled or raw water (ditch water, pond, well, etc.) is used for irrigation on the premises, an approved University of Southern California (USC) backflow prevention assembly (containment) shall be installed 5 feet downstream from the meter pit on any potable water service line. The backflow assembly type is determined by the degree of hazard downstream from the meter (RP-High Hazard installed above ground or DC-Low Hazard installed below ground – 60 inch diameter manhole). For additional information, please reference Denver Water's Engineering Standards, 6.11, or contact Cross-Connection Control at 303-628-5940.
 - A soil amendment will be required on every property requiring new water service.

DISCLAIMER: Denver Water Standard Operating Procedures represent recommended practices that should be applicable to most situations encountered. These procedures should be followed to the extent applicable; however, they by no means represent the only method to perform the tasks they describe. It is understood that field conditions, emergencies, and other circumstances may require deviation from Standard Operating Procedures.

SHEET NUMBERING ON LANDSCAPE AND IRRIGATION PLANS FROM ORIGINAL BID SET. ACTUAL SHEET NUMBER = SHEET NUMBER + 1. TOTAL NUMBER OF SHEETS = 32.



Know what's below.
Call before you dig.

HydroSystems-KDI, Inc.

860 Tabor Street, Suite 200
Lakewood, Colorado 80401
303-980-5327
303-980-5384 (fax)

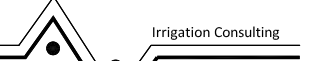

NO.	DESCRIPTION OF REVISIONS	DATE	BY

CALL UNCC
TWO WORKING DAYS
BEFORE YOU DIG
1-800-922-1087
UTILITY INTERFERENCE CENTER
COLORADO

CITY AND COUNTY OF DENVER
DEPARTMENT OF PUBLIC WORKS
ENGINEERING DIVISION
CAPITAL PROJECTS MANAGEMENT
2000 W. 3RD AVE. DENVER, CO 80223
TEL.: (303) 446-3617 FAX: (303) 446-3647

HAMPDEN HEIGHTS STORM SEWER
IMPROVEMENTS - PHASE III
E. GIRARD AVE. OUTFALL
PCO CONTROL NO:
PILAR REVIEW NO:
DENVER WATER INSTALLATION INFORMATION

DRAWN BY:	AMC
DESIGNED BY:	AMC
APPROVED BY:	KJD
DRAWING NAME:	5234-HHS-Pond-IRR-CD-DPR Set.dwg
DATE:	12/11/14
SHEET NO.:	31 of 31

LIST OF IRRIGATION DRAWINGS

24	SHEET INDEX & NOTES
25	IRRIGATION PLAN
26	IRRIGATION PLAN & DETAILS
27-28	IRRIGATION DETAILS
29	IRRIGATION CHARTS
30-31	DENVER WATER INFORMATION

CONTRACT DOCUMENTS FOR

HAMPDEN HEIGHTS STORM SEWER IMPROVEMENTS - PHASE III

PILAR REVIEW NO.: 2011-0426-01

PRO CONTROL NO.: PWC2009-5013



DENVER
THE MILE HIGH CITY

**CITY AND COUNTY OF DENVER
DEPARTMENT OF PUBLIC WORKS
ENGINEERING DIVISION**

PREPARED BY:



ENGINUITY ENGINEERING SOLUTIONS
10106 W. San Juan Way, Ste 215
Littleton, CO 80127

DECEMBER 2014

TABLE OF CONTENTS

SECTION	ITEM
GENERAL CONTRACT CONDITIONS	
A	Reserved
WASTEWATER CAPITAL PROJECTS MANAGEMENT STANDARD CONSTRUCTION SPECIFICATIONS	
1.0	Scope
01-1416	Public Information Services
01-5213	Temporary Office Facilities
2.0	Site Preparation
02-2213	Vibration Assessment
3.0	Existing Facilities
4.0	Utility Trenching and Excavation
5.0	Bedding and Backfilling
6.0	Surface Restoration
7.0	Pipe Jacking, Boring, Casing and Micro Tunneling
8.0	Structural Excavation
9.0	Testing, Inspection and Acceptance
10.0	Storm/Sanitary Sewer Pipe and Culverts
11.0	Structures and Appurtenances
12.0	Riprap and Slope/Channel Protection
13.0	Fencing
14.0	Removal and Disposal of Construction Debris and Contaminated Materials
15.0	Manhole Rehabilitation
20.0	Grass Sodding
21.0	Sprinkler Systems

22.0 Seeding

23.0 Storm Water Management Plans (SWMPs)

25.0 Hot-Mix Asphalt Pavement

26.0 Excavation and Embankment

31-3223.12 Soil Improvement by Compaction Grouting

47.0 Construction Survey and Monumentation

DENVER PARKS AND RECREATION STANDARD SPECIFICATIONS

02810 Irrigation System

SUPPLEMENTAL INFORMATION

- A. Measurement and Payment
- B. Final Geotechnical Investigation Report, Hampden Heights Phase II, Drainage Improvements, Denver, CO; Yeh and Associates, Inc.; October 17, 2014.
- C. Corps of Engineers 404 Permit

REVISIONS TO SPECIFICATIONS

R1 Revision of Technical Specifications 11.0
Concrete

R2 Revision of Technical Specifications 21.0
Sprinkler Systems

R3 Revision of Technical Specifications 23.0
Storm Water Management Plans (SWMPs)



DENVER

PUBLIC WORKS

CITY AND COUNTY OF DENVER
ENGINEERING DIVISION

Wastewater Capital Projects Management Standard Construction Specifications

September 26, 2014



CITY AND COUNTY OF DENVER
ENGINEERING DIVISION

Wastewater Capital Projects Management Standard Construction Specifications

Table of Contents

<i>Section</i>	<i>Page</i>
1.0	Scope.....1-1
01-1416	Public Information Services.....011416-1
01-5213	Temporary Office Facilities.....015213-1
2.0	Site Preparation.....2-1
02-2213	Vibration Assessment022213-1
3.0	Existing Facilities.....3-1
4.0	Utility Trenching and Excavation.....4-1
5.0	Bedding and Backfilling5-1
6.0	Surface Restoration.....6-1
7.0	Pipe Jacking, Boring, Casing and Micro Tunneling
7.1	Tunneling, Jacking and Boring7.1-1
7.2	Micro Tunneling.....7.2-1
7.3	Shaft Excavation and Support.....7.3-1
7.4	Permeation Grouting7.4-1
7.5	Compensation Grouting7.5-1
8.0	Structural Excavation.....8-1
9.0	Testing, Inspection and Acceptance9-1
10.0	Storm/Sanitary Sewer Pipe and Culverts
10.1	Precast Concrete Pipe.....10.1-1
10.3	Precast Reinforced Box Conduits.....10.3-1
10.4	Reinforced Polymer Mortar Pipe10.4-1
10.5	Ductile Iron Pipe10.5-1

10.6	Polyvinyl Chloride (PVC) Sewer Pipe	10.6-1
10.7	Cured In Place Pipe	10.7-1
10.20	Pipe Bursting	10.20-1
11.0	Structures and Appurtenances.....	11-1
12.0	Riprap Boulders and Slope/Channel Protection	12-1
13.0	Fencing.....	13-1
14.0	Removal and Disposal of Construction Debris and Contaminated Materials	14-1
15.0	Manhole Rehabilitation.....	15-1
15.1	Cured-In-Place Fiberglass/Epoxy Resin Liner	15.1-1
15.2	Spectrashield™ Manhole Liner.....	15.2-1
15.3	High Build Novolac Epoxy	15.3-1
20.0	Grass Sodding.....	20-1
21.0	Sprinkler Systems	21-1
22.0	Seeding.....	22-1
23.0	Storm Water Management	23-1
25.0	Hot-Mix Asphalt Pavement	25-1
26.0	Excavation and Embankment	26-1
31-3223.12	Soil Improvement by Compaction Grouting.....	31322312-1
47.0	Construction Survey and Monumentation	47-1

Supplemental Information

Measurement and Payment.....	Pages 1 thru 51
------------------------------	-----------------



CITY AND COUNTY OF DENVER
ENGINEERING DIVISION

Wastewater Capital Projects Management Standard Construction Specification

01-00 Scope

These Standard Construction Specifications set forth the provisions applicable to storm, sanitary and other related construction on Wastewater Capital projects, as specified. The general contractor is responsible for all materials and equipment necessary to perform all operations in connection with the construction of the facilities as described in approved plans, the most recent edition of these Standard Construction Specifications and the Wastewater Management Division Standard Details.

END OF SPECIFICATION



CITY AND COUNTY OF DENVER
ENGINEERING DIVISION

Wastewater Capital Projects Management Standard Construction Specification

01-1416 PUBLIC INFORMATION SERVICES

PART 1- General

1.01 Description

The Work consists of providing various public involvement activities for the Project. Additional requirements may be included elsewhere within the Contract Documents.

Public information services shall include, at minimum, the following:

- a) Responding to questions concerning Project activities and schedules
- b) Participating in, and documenting meetings held with affected individuals, residents and/or business
- c) Maintaining ongoing communication with residents and businesses directly impacted by construction activities and traffic control plans for the project
- d) Maintaining a written log which documents calls and concerns. The log shall include: the nature of the concern, response(s) provided, date of completion for any required remedial action and any necessary future follow up with a frequency.

1.02 Submittals

The following shall be submitted to the Construction Project Manager:

- a) All construction notification letters intended for use on the project, shall be submitted for approval by the Construction Project Manager prior to issuance of a notice to proceed. Updated notification letters intended for distribution to the public will require re-review and approval prior to issuance and may require additional time for coordination through the district City Council office.
- b) The qualifications of the Contractor's assigned Public Information Manager shall be submitted to the Construction Project Manager prior to the preconstruction meeting for review
- c) An updated written log for calls and concerns received will be submitted on a weekly basis, unless directed otherwise

Part 2 – Product

Part 3 – Execution

3.01 Public Information Manager

A Public Information Manager (PIM) for the Project shall be designated by the Contractor at the preconstruction meeting. The PIM shall be primarily responsible for maintaining communications and providing information on a regular basis to businesses and property owners affected by and adjacent to the work. The PIM shall be available on every calendar day and at all times during the course of the project from Contract Award through issuance of Final Acceptance. Interpretation services may be necessary and must be made available to ensure appropriate assistance is provided.

The PIM shall have a minimum of two Projects of previous experience in work with communications on similar Projects.

If directed by the Construction Project Manager, the PIM shall:

- a) attend regularly scheduled meetings of local neighborhood and business associations to discuss the project and schedule
- b) provide interpretation services
- c) distribute additional notifications to the public which provide project related information, service interruptions, or general construction progress updates
- d) provide timely input and review public information intended for use in neighborhood newsletters or publications, City Council updates, and local news media interviews or articles
- e) provide information, documents, photographs, input and review for information posted on City sponsored websites
- f) coordinate and communicate with adjacent projects/work, as well as utility companies working within the project limits to ensure proper notification of effected residents and business owners occurs and does not negatively impact the project

3.02 Public Information Phone Line

The Contractor shall provide a public information, local call line for the Project which is accessible 24 hours a day, 7 days a week. The public information line shall be answered by a person with direct knowledge of the Project or by an answering machine with current Project information that is updated on a weekly basis and allows the recording of a message from the caller. Cellular phones are acceptable. All calls shall be returned by the PIM or their designee within 24 hours. This phone number shall also appear on the project signs and on all information distributed for the Project.

3.03 Construction Notification Letter

The Contractor shall be required to prepare, submit for review and distribute construction notifications a minimum of 7 calendar days prior to starting work on each block. Notification and coordination shall occur with: property owners, tenants and/or businesses directly adjacent to or affected by the work, as well as those on side streets near the work site. It is the Contractor's responsibility to maintain ongoing communication with the affected property owners, tenants and/or businesses.

The notification shall provide a brief summary of the Project scope, work activities associated with the type of construction, general safety guidelines for the public and an anticipated completion date for the Project. In addition, the notification shall provide the name of the PIM and their telephone number. Notifications shall be updated and redistributed every two to three weeks until construction is completed. The Contractor shall allow time for the Construction Project Manager to review and approve all updated notification letters prior to distribution.

End of Specification



CITY AND COUNTY OF DENVER
ENGINEERING DIVISION

Wastewater Capital Projects Management Standard Construction Specification

01-5213 TEMPORARY OFFICE FACILITIES

PART 1- General

1.01 Description

This specification covers temporary office facilities during construction activities above that normally provided by the Contractor for use by the City and their designated personnel. This specification only applies when the corresponding bid item for temporary office facilities is included and is specifically stipulated in the contract documents.

The purpose of the temporary office facilities is to provide the necessary working area and resources for project team member meetings, City Construction Project Managers, City Construction Project Inspectors, Project Resident Engineers, or their designees.

The City and County of Denver is not responsible for the safety of the temporary office facilities and compliance with this specification does not relieve the Contractor of full responsibility for damage caused by the Contractor's operations.

1.02 Submittals

All submittals for this item shall be provided to the City Construction Project Manager for record keeping purposes and verification of conformance with the contract documents. These submittals or approval of the submittals does not shift liability or relieve the Contractor from full responsibility for adherence to specification.

Provide a detailed submittal for review and acceptance by the City Construction Project Manager detailing the product requirements described in Part 2 of this specification. Detail the location and layout of the temporary office facilities in the submittal(s).

PART 2- Product

2.01 Temporary Office Space

The Contractor shall furnish and maintain a temporary office facility at or adjacent to the work site for use by City Construction Project Managers, City Construction Project Inspectors, Project Resident Engineers, and/or their designees. An individual desk space is required for City Construction Project Inspectors, the City Construction Project Manager,

and/or Project Resident Engineer; and additional space may be needed for specialty inspectors (geotechnical, structural, etc.)

Each individual desk space shall include one standard size desk with drawers, one desk chair and one side chair, a book case, a plan rack, a waste basket, lighting (50 foot candles at desk top), a duplex electrical outlet (110-volt), access to high speed internet (minimum 20Mbps), and a printer (capable of printing and scanning standard, legal, and 11-inch by 17-inch color prints).

The temporary office shall be structurally sound, secure, vandal resistant, weather tight, with floors raised above ground and have interior and exterior lighting. The temporary office shall be provided with automatic heating and mechanical cooling equipment to maintain comfort conditions of 70 degrees Fahrenheit year round and provide convenient access to potable drinking water and toilet facilities cleaned at least twice per month.

2.02 Temporary Meeting Space

The Contractor shall furnish and maintain a temporary meeting space at the work site within the temporary office facility for use by project team members during meetings. The temporary meeting space shall be large enough to accommodate at least 8-persons, including a table and chairs. The meeting space shall have multiple wall mounted cork boards and white boards and a large wall mounted display clock for help in facilitating meetings.

PART 3- Execution

Provide the City with and maintain full access to the temporary office facilities at least two weeks prior to starting ground disturbance at the project site. Allow the City and/or their designees' full access to the temporary office facilities during the duration of the project; including weekends, nights, and holidays if warranted by the project. Provide temporary access roads and maintenance if required to maintain access to the temporary office facilities. Provide snow removal as required.

The temporary office facilities shall be removed within 30 days after they are no longer needed or as directed by the City Construction Project Manager.

END OF SPECIFICATION



CITY AND COUNTY OF DENVER
ENGINEERING DIVISION

Wastewater Capital Projects Management Standard Construction Specification

2.0 Site Preparation

2.0.1 General

The site of all trenches shall be cleared of all vegetation, stumps, roots, sod, and debris prior to excavating. Fences, walls, curbs, sidewalks, gutters, crossspans, poles, or any other structures stipulated on the drawings to be removed, or otherwise authorized by the Construction Project Manager to be removed, shall be removed and later replaced in a manner acceptable to the City and equivalent to its original undisturbed condition. Except as otherwise shown on the Drawings or otherwise specified herein all unsalvageable materials shall be removed or hauled from the site and disposed of by the Contractor at his expense. Unless otherwise specified in the Contract Documents or elsewhere in these Standard Construction Specifications, all salvageable materials and items shall become the property of the City. If, in the event it is specified that certain salvageable materials are to become property of the Contractor, no payment will be made for the removal of those items or materials.

2.0.2 Stockpiling of Excavated Materials, Pipe, Etc.

In accordance with and in addition to the requirements set forth in GC's 801-807 of the General Contract Conditions, no excavated materials, pipe, equipment, or any other items shall be stockpiled or stored on private property without the express written approval of the property owner of record. Duplicate copies of any written approval or authorization given to the Contractor shall be submitted to the Construction Project Manager and shall be so worded as to hold harmless the City of any responsibility whatsoever related to the stockpiling and storage of material and equipment. All costs incurred shall be borne by the Contractor.

2.0.3 Construction Easements

All additional temporary construction easements that the Contractor feels are necessary to perform the required work shall be coordinated, obtained and paid for by the Contractor. If these easements are granted to the Contractor, they shall be so worded as to hold harmless the City of any responsibility whatsoever related to any temporary construction easement obtained by the Contractor. Duplicate copies of the written authorization shall be submitted to the Construction Project Manager. All costs incurred under this item shall be borne solely by the Contractor.

End of Specification



CITY AND COUNTY OF DENVER
ENGINEERING DIVISION

Wastewater Capital Projects Management Standard Construction Specification

02-2213 Vibration Assessment

Part 1 - General

1.01 Description

This specification covers vibration monitoring during construction activities to include an existing condition survey, baseline equipment monitoring and the establishment of a vibration monitoring program for use during construction operations. . This specification only applies when the corresponding bid item for vibration assessment is included and is specifically stipulated in the contract documents.

The purpose of the vibration monitoring program is to assess possible impacts that construction activities might have to adjacent facilities during all phases of the work. These facilities include, but are not limited to buildings, bridges, underground utilities, surface facilities, structure foundations, and all other facilities within the proximity of the work.

The City and County of Denver is not responsible for the safety of the Work and compliance with this specification does not relieve the Contractor of full responsibility for damage caused by the Contractor's operations.

1.02 Submittals

All submittals are submitted to the Construction Project Manager for record keeping purposes and verification of conformance with the contract documents. These submittals do not shift liability or relieve the Contractor from full responsibility for damage that is deemed to be caused by the Contractor's operations.

A. An independent vibration monitoring consultant will be used to fulfill the

- requirements of this section. The Contractor shall submit references for the consultant detailing at least two projects completed in the past five years where the vibration monitoring consultant has satisfactorily monitored construction operations by recording maximum peak particle velocities (PPVs). Include contact information for each reference. This information shall be submitted to the Construction Project Manager for acceptance prior to beginning use of the Consultant's services.
- B. The Contractor shall submit any facility condition survey that is done to the Construction Project Manager within 2 weeks of completion of the survey.
 - C. At a minimum, the Contractor shall submit any data and documentation derived from vibration monitoring along with interpretations of the results from the vibration monitoring consultant to the Construction Project Manager on a monthly basis.
 - D. The contractor shall offer formal training on how to access any web base data access site. A technical manual detailing all procedures for accessing the site shall be offered at the training session and submitted to the Construction Project Manager.

Part 2 – Product

Part 3 – Execution

3.01 Facility Condition Survey

This work shall consist of performing a facility condition survey(s) and preparing permanent records as indicated in this specification prior to the commencement of work, after completion of work, and at locations and times during construction as needed to verify that adjacent facilities have not been damaged by any element of the work.

3.02 Vibration Monitoring Consultant

- A. The Contractor shall, as specifically indicated in this specification, provide vibration monitoring to verify that construction activities will not or have not damaged adjacent facilities.
- B. The Contractor will obtain the services of an independent vibration monitoring consultant to assist in developing an existing condition survey, establish a vibration monitoring plan to include baseline and continuous monitoring, and interpret the results of the vibration monitoring as it relates to adjacent facilities.
- C. Vibration monitoring will be done near elements of the construction work which are likely to have the largest potential to damage adjacent facilities during the course of construction operations. This monitoring will be used to establish a baseline reading of these activities and will be done at a location of the work

which is least likely to damage adjacent property. The vibration monitoring consultant will review the results of the baseline monitoring program and submit the results and their interpretation of the findings to the Construction Engineer in a report submitted on a monthly basis.

- D. Vibration monitoring will take place on a continuous basis during all construction activities. Continuous vibration monitoring will be done throughout the project at locations that are nearest the construction activities and which have the potential to damage nearby facilities. The location and number of vibration monitoring instruments will be as directed by the vibration monitoring consultant based on the results of the baseline monitoring, their interpretation of these results, and their experience based on the type of activity and proximity to nearby facilities.
- E. The Consultant/Contractor shall provide protection for all instrumentation from vandalism or theft. Any costs associated with vandalism or theft shall be born by the general contractor. The City and County of Denver shall at no time entertain any claim for loss associated with vandalism or theft of instrumentation.
- F. The vibration monitoring consultant will be a PE licensed in the state of Colorado, and will have performed vibration monitoring services in Colorado to include monitoring construction operations to record maximum peak particle velocities.
- G. The Consultant/Contractor will submit monthly reports to the Construction Project Manager which detail the baseline monitoring results, a summary of the continuous vibration monitoring results at locations nearest the construction activities and include a summary interpretation of all the results collected over the past month.

END OF SPECIFICATION



CITY AND COUNTY OF DENVER
ENGINEERING DIVISION

Wastewater Capital Projects Management Standard Construction Specification

3.0 Existing Facilities

3.0.1 General

The Contractor shall at all times take extreme and proper precautions for the protection of utilities, the presence of which are known or can be determined by the examination of appropriate utility maps, use of electronic locating, exploratory excavations, etc. The Contractor shall be responsible for all costs associated with the repair of any service and/or utility damaged by construction.

The Contractor shall notify Denver Water, Xcel Energy, telephone, cable and fiber optic companies, as well as property owners and all other interested parties, prior to commencement of work in order to ensure that there will not be service interruptions during construction. Existing utility lines and utility poles, trees, shrubbery, fences, water mains, gas mains, sewers, cables, conduits, curb, gutter, walks, and other structures in the vicinity of the work not authorized to be removed, shall be supported and protected from damage by the Contractor until all construction and related work is complete. The Contractor shall be liable for all damages to existing facilities, structures, and property.

3.0.2 Utilities

Utilities, underground and above-ground, shall include but not be limited to: fiber optics (including empty ducts), gas, telephone, electric, steam, water, sanitary and storm sewers, telegraph lines, conduits, all abandoned utilities, etc., and their accessories, appurtenances and service connections. The type, size, location, and number of all known above-ground and underground utilities have been shown on the drawings, however, no guarantee is made as to the true size, location or number of such utilities. It shall be the responsibility of the Contractor to verify the existence and location (vertically and horizontally) of all underground utilities along the route of the work, to ensure construction as shown in the Contract Documents. The omission from or the inclusion of existing or abandoned utility locations on the drawings is not to be considered as the nonexistence of, or a definite location of, said utilities.

3.0.3 Exploratory Excavations

Exploratory excavations shall only be paid at locations designated in the Contract Documents or as specifically approved by the Construction Project Manager, in writing. Otherwise, all costs incurred by the Contractor in making exploratory excavations shall be considered to be

included in the unit price bid for constructing each section of sewer line, structures, laterals and/or appurtenances.

In addition to those areas as may be designated in the Contract Documents, it shall be the Contractor's responsibility to excavate and locate all utilities and appurtenances which may affect construction or require protection during construction of the project scope. All exploratory excavations shall occur far enough in advance of the sewer facility construction to permit any necessary relocation or adjustment of the sewer facility without delaying the project.

3.0.4 Relocation and Adjustment

If it is determined prior to, or during construction that any underground or aboveground utilities (as defined within this specification) are required to be relocated or adjusted, the Contractor shall notify the utility owner well in advance of the Contractor's approach of such utility so that arrangements with the owner or owners of the affected utility can be completed without delaying construction. It is the Contractor's responsibility to coordinate all utility relocations and adjustments required to complete the scope of work designated within the construction plans and documents. All utilities requiring relocation and/or adjustment shall be constructed in accordance with each specific owner's requirements, standard specifications, and applicable agreements. The costs associated with utility coordination, relocations, adjustments; and/or construction delays due to improper planning, scheduling or advance notification of utility owners by the Contractor, shall be included within the related pipe segments, structures and appurtenances. Unless otherwise provided for in the Contract Documents or specified elsewhere, the responsibility of relocating both underground and aboveground utilities within the project limits shall be borne by the Contractor. If operations by the Contractor cause damage to any utilities lying outside of the prescribed maximum trench width the utility shall be repaired at the sole expense of the Contractor. The Construction Project Manager may order such utilities to be protected or relocated at the sole expense of the Contractor.

3.0.4.1 Water Services

The type, size and location of water services are not shown on the construction plans and it shall be the Contractor's responsibility to identify and locate the services affected during construction. The Contractor is required to coordinate all water service relocations with Denver Water, well in advance of approach

The Contractor is required to maintain service and adjust all water service taps and/or connections encountered during construction. Service adjustments and reconnections for homeowners, businesses, and facilities with special circumstances will be completed during a timeframe which accommodates their needs. All work will be performed by a licensed plumber or journeyman drainlayer and shall be in accordance with Denver Water Standard Construction Specifications. No separate payment will be made for any of the work involved for this item and all costs incurred will be considered to be included in the applicable unit price bid for the associated pipe segments, structures and appurtenances.

3.0.4.2 Gas Services

The type, size and location of gas services are not shown on the construction plans, and it shall be the Contractor's responsibility to identify and locate the services affected during construction. The Contractor is required to coordinate all gas service relocations with the utility owner, well in advance of approach. All work involved and costs incurred for this

item will be included within the applicable unit price bid for the associated pipe segments, structures and appurtenances.

3.0.4.3 Sewer Services

1. Adjusting

All storm and sanitary sewer services and/or connections crossed during construction shall be adjusted by the Contractor as required to maintain service. A licensed plumber or a licensed drainlayer shall perform all such work. Unless otherwise provided for in the Contract Documents, no separate payment will be made for any of the work involved for this item and all costs incurred will be considered to be included in the applicable unit price bid for the associated pipe segments, structures and appurtenances.

2. Reconnection

Where existing sanitary and/or storm sewer lines with service and/or lateral connections are being replaced, reconnection will be required at the locations shown in the contract documents, in addition to those located in the field by the Contractor and identified by the Construction Project Manager as active connections. Reconnection will also be required where a service or lateral connection was damaged as a result of work associated with this project. The contractor is also required to immediately and fully mitigate all damage to public or private property associated with the damaged service and/or lateral connection. This full and immediate mitigation shall be conducted regardless of apparent "fault" of the damage. The connections shall be reconnected by the Contractor utilizing standard tee or wye fittings, factory manufactured saddle taps, applicable pipe and reinforced concrete collars, adjustable repair couplings, etc. as specifically approved for construction by the Construction Project Manager. All service connections on PVC lines shall be constructed in accordance within these Standard Construction Specifications. Connections to sewer lines and structures shall be made using coring machines, keyhole saws, or other methods approved by the Construction Project Manager; jack-hammering or break in connections are not permitted. The Contractor will perform this work utilizing a licensed plumber or journeyman drainlayer. All connections must be reconnected to the new sewer line within twelve hours of discontinuance of service.

3. Location and Verification

All sewer services and/or lateral connections shall be located and verified by the Contractor prior to construction (both vertically and horizontally). The Contractor shall notify the owner well in advance of access to mainline sewers to allow coordination and planning with the pertinent maintenance groups. All costs associated with delays and maintenance of mainline facilities will be incurred by the Contractor. The Construction Project Manager shall be notified immediately of any information acquired from locates and verifications which may affect the design or original scope of work.

Unless provided for elsewhere in the Contract Documents or specified elsewhere, no separate payment will be made for any of the work involved for these items and all costs incurred will be included in the applicable unit price bid for the associated pipe segments, structures and appurtenances.

3.0.5 Abandonment

All existing sewer facilities to be plugged and abandoned in place are specifically shown on the Construction Drawings. Unless otherwise specified in the Contract Documents or elsewhere in the Special Conditions, the procedures and methods for the abandonment of said facilities shall conform to the following.

3.0.5.1 Manholes/Inlets/Structures

Manholes, inlets or miscellaneous structures to be abandoned in place shall have all pipes entering or exiting the structure plugged with lean concrete. Manhole tops or cone sections shall be removed to the first full barrel diameter section, and/or to a point not less than 24-inches below final grade. The structure shall then be backfilled and compacted in accordance with Backfill Method B as specified within these Standard Construction Specifications. Backfill material may be either: select backfill, clean suitable excavated material, or controlled low strength material approved by the Construction Project Manager. Surface restoration for the surrounding area shall be done in accordance within these Standard Construction Specifications.

Manhole rings, covers, inlet grates, frames, precast flat tops, cone sections, or other salvageable items shall be salvaged, stored and delivered to such location as prescribed by the Construction Project Manager.

The payment for abandoning manholes, inlets, and/or miscellaneous structures as described above; along with the materials, equipment and labor necessary to complete all surface restoration associated with these items shall be included within the appropriate bid item (regardless of the size or depth of item abandoned). Refer to applicable Measurement and Payment description for specific item inclusions.

3.0.5.2 Sewer Lines

Sewer lines to be abandoned in place shall be plugged with lean concrete and standard manufactured plugs or caps at both upstream and downstream ends of the abandoned section. If the manholes, inlets, etc. are also abandoned in place, or if the structure is to be removed completely, all sewer lines shall be plugged upstream and downstream of the removed structure following removal.

Sewer lines with an internal diameter of 24-inches or larger shall be filled with sand, pumped grout mixtures, or flowable fill, prior to final plugging. Unless otherwise noted in the Contract Documents, sewer lines with an internal diameter of 21-inches and smaller shall be plugged at entrance and exit ends with approved grout mixtures or concrete.

Unless provided for elsewhere in the Contract Documents or specified elsewhere, no separate payment will be made for any of the work involved for these items and all costs incurred will be included in the applicable unit price bid for the associated pipe segments, structures and appurtenances.

3.0.6 Crossing of Existing Utilities

See Wastewater Management Division Standard Detail S-350, for requirements and general notes.

End of Specification



CITY AND COUNTY OF DENVER
ENGINEERING DIVISION

Wastewater Capital Projects Management Standard Construction Specification

4.0 Utility Trenching and Excavation

4.0.1 General

All excavations, trenching, shoring and stockpiling of excavated materials shall be in strict compliance with the applicable Occupational Safety and Health Act (OSHA) rules and regulations.

Except where shown otherwise on the Drawings, and except when the Construction Project Manager provides written permission to do otherwise, all trench excavation shall be made by open cut to the depth required to construct the pipe line as shown on the Drawings and specified herein. Permission for tunnel work may be granted by the construction project manager for crossing under sidewalks, driveways, or existing utility lines. No separate payment will be made for any of the work involved for these items and all costs incurred will be included in the applicable unit price bid for the associated pipe segments, structures and appurtenances.

The length of trench permitted to be open at any one time may be limited when, in the opinion of the Construction Project Manager, such limitation is necessary for the safety and convenience of the public; however, in no case shall the length of open trench exceed 400 feet, except when the Construction Project Manager provides written permission to do otherwise. All trenches and excavations left overnight shall be protected as specified by the Construction Project Manager. This may include, but is not limited to: fencing, concrete, barriers, additional signage or any other measures required to provide public safety.

4.0.2 Subsurface Information

Whenever subsurface exploration, consisting of test holes and borings, has been made along the route of the work, the information obtained from these test holes will be included in both the Bid Submittal Package and the Contract Documents.

Subsurface information is provided for general information, and conditions may vary due to the location on jobsite and time of year. The City does not accept any responsibility for assumptions or generalizations made by the Contractor. Each bidder and Contractor must form their own opinion of the character of the work and of the materials to be excavated, and must make their own interpretations and investigations regarding all conditions affecting the work to be done.

4.0.3 Trench Width

Except as may be otherwise specified on the Drawings, the maximum clear trench width measured at a point one (1) foot above the top of the pipe barrel shall not be greater than that set forth in the most recent edition of the Wastewater Management Division Standard Detail Drawings.

The trench width shall be sufficient to permit the pipe to be placed and jointed properly and to allow for the construction of appropriate structures and appurtenances. Adequate width shall be provided to allow backfill to be placed and compacted as specified. Pipe shall not be installed in a bedding trench having a width (as measured one (1) foot above the top of the pipe) greater than the outside diameter of the pipe plus sixteen (16) inches for pipe having internal diameters of thirty-three (33) inches or less. Bedding trench shall not be greater than the outside diameter of the pipe plus twenty-four (24) inches for all pipes with internal diameters of thirty-six (36) inches or more.

If the stated maximum trench widths are exceeded either through accident or otherwise and if the Construction Project Manager determines that the design loading of the pipe will be exceeded, the Contractor will be required to either support the pipe with an improved trench bottom or to use a stronger class of pipe. The cost of such remedial measures shall be entirely at the Contractor's own expense. If deemed necessary, the Contractor shall brace or shore this portion of the trench excavation to maintain the required trench width at the top of the pipe.

4.0.4 Trench Walls

All trench sidewalls shall be properly sloped, benched, braced, shored or sheeted to assure safe working conditions and to prevent cave-ins. All trench operations including sloping or benching of the trench sidewalls and stockpiling of excavated materials shall be confined to the width of the permanent rights-of-way plus any temporary construction easements.

4.0.4.1 Sloping or Benching

Sloping or benching of the trench walls will normally be allowed, provided that such sloping or benching complies with all applicable State and Federal requirements as defined within these Standard Construction Specifications; and provided further, that such sloping or benching does not endanger adjacent utilities or structures or the public. In the event the Contractor elects to slope or bench the trench sidewalls, the sloping or benching shall terminate at a depth not less than one (1) foot above the top of the pipe barrel and, from that point to the bottom of the excavation, the trench wall shall be vertical (with adequate shoring as necessary). All additional costs for backfilling and surface restoration, for trenches which exceed the maximum width defined within the Standard Constructions shall be borne by the Contractor.

4.0.4.2 Bracing Shoring, Sheeting

The sides of the excavation shall be securely held in place with suitable bracing and shoring wherever necessary to prevent caving. In addition, bracing, shoring, sheeting, etc. shall be in accordance with all applicable State and Federal. Shoring shall be removed as the work and backfilling operations progress, unless ordered by the Construction Project Manager to be left in place. The Contractor will be responsible for minimizing the disturbance of compacted bedding during advancement and removal of shoring within the bedding trench

zone. All voids and separations shall be backfilled and recompact with the appropriate bedding materials and in conformance with these Standard Construction Specifications. The Contractor will be paid for shoring so ordered left in place on the basis of invoiced material only. All other shoring shall be considered as incidental to construction and all costs incurred, except for materials ordered to be left in place, will be considered to be included in the unit price bid for the construction of each section of sewer, associated structures, laterals and appurtenances.

The decision to brace, shore or sheet the excavation shall be entirely the Contractor's responsibility. However, if the Construction Project Manager is of the opinion that any part of the excavation is not properly supported, the placement of additional supports or implementation of other methods by and at the expense of the Contractor may be required. Compliance with such order shall not relieve or release the Contractor from his/her responsibilities to provide a safe work zone.

4.0.5 Preparation of Foundation for Pipe Laying

When the excavation is in firm soil, care shall be taken to avoid excavation below the established grade (i.e. the specified overdepth to accommodate the particular class of bedding). The different methods and classes of bedding are described within these Standard Construction Specifications.

4.0.5.1 Dewatering

During construction, the Contractor shall provide and maintain adequate equipment to properly remove and dispose of all water entering the trench or other part of the work. In water bearing strata, well points, sub drains or any other method approved by the Construction Project Manager that may be required to provide a dry trench.

Pipe trenches shall be kept free from water during excavation, fine grading, pipe laying and jointing. Dewatering, sufficient to provide a completely dry trench, shall be maintained during all pipe laying and jointing operations. The Contractor shall be responsible for damage resulting from the dewatering operations.

The discharge from any trench dewatering operations shall be conducted to natural drainage channels or other structures as approved by the Construction Project Manager and in accordance with applicable permits. Ground water shall not be discharged into sanitary sewers.

Unless provided for in the Contract Documents, dewatering shall be considered as incidental to construction and all costs incurred will be considered to be included in the unit price bid for the construction of each section of sewer line, associated structures, laterals and appurtenances.

4.0.5.2 Overexcavation and Replacement with Select Backfill Material

If soft or otherwise unsuitable foundation material is encountered during the course of completing the work, it shall be removed and replaced with select backfill material and/or angular rock bedding material so as to provide a suitable foundation for the pipe, structure and/or appurtenance or roadway, as determined by the Construction Project Manager.

In the event that overexcavation and replacement with select backfill material is below the water table, the sub-bedding material shall consist of 3/4 to 1-1/2-inch rock (or larger if

approved). All work shall conform to the most recent edition of the Wastewater Management Division Standard Details.

If provided for in the Contract Documents, the cost of overexcavation and replacement with select backfill material will be paid for per the associated measurement and payment description. If no pay item for such work is included in the Contract Documents, the Contractor shall consider all costs incurred to be included in the unit prices bid for the construction of each section of sewer, associated structures, laterals and appurtenances.

At the option of the Construction Project Manager, select backfill material meeting the requirements of these Standard Construction Specifications may be delivered to the job site for the Contractor's use. The Contractor will be paid for placement of this material and the removal and disposal of the overexcavated material per the associated measurement and payment description.

4.0.6 Unsuitable Materials Excavation

Unsuitable material encountered within an excavated area during construction shall be excavated and disposed of by the Contractor as directed by the Construction Project Manager. Payment for excavation, disposal and replacement of unsuitable materials will not be paid for unless specifically authorized in writing by the Construction Project Manager. It may be necessary for the Contractor to rework, solely at the Contractor's own expense; dry, wet or otherwise satisfactory excavated material as necessary to obtain conformance with backfill requirements. Unsuitable materials are defined as:

1. Rock Excavation: Rock shall be defined as material consisting of igneous, metamorphic and sedimentary materials which cannot be excavated without blasting or the use of rippers, or boulders or other detached stones having a volume of ½ cubic yard or more, or having a specific gravity of at least 2.24 and weight not less than 140.4 pounds per cubic foot. The unit price bid for rock excavation will include granular bedding, select material, or any other material specifically approved in writing by the Construction Project Manager required to fill the excavated area.
2. Soil and excavated material containing rubbish, organics, frozen material, broken pavement, debris, stones larger than three (3) inches in diameter.
3. Muck, defined as an organic soil consisting of highly decomposed materials with more than 30% organic material and are generally referred to as peat or muck. These soils have bulk densities as low as 25 to 37 lb/ft³.
4. Material determined to be of such an unstable nature as to be incapable of being compacted to the specified density using ordinary methods, at optimum moisture content.
5. Material which is too wet to be properly compacted and circumstances prevent suitable in-place drying prior to incorporation into the work.
6. For backfill to be used within a street, roadway or any other area where the degree of compaction is critical, material having a plasticity index greater than twenty (20) shall be considered unsuitable.
7. Material otherwise unsuitable for the planned use per the Contract Documents.

4.0.7 Pavement and Sidewalk Cuts

Where excavation is required under concrete or asphalt paved areas, including gutters and walks, the surfacing material shall be cut or rotomilled in such a manner as to produce a smooth, structurally sound, straight cut edge and confine the excavation to a minimum practical width. All pavement removals shall be neatly cut, rectangular or trapezoidal in shape, and edges shall be parallel, perpendicular or skewed up to 45°. The pavement or concrete shall be cut or removed at least one (1) foot beyond the top width of the trench on each side. All broken pavement, asphalt, concrete or other debris resulting from this initial work shall be immediately removed from the job site or stockpiled in an approved manner so that it is kept separated from the remaining trench excavation. This debris will not be allowed to be mixed in the trench backfill material.

4.0.8 Cut-off Walls

Cut-off walls are only required as noted in the contract documents and as specifically requested by the Construction Project Manager to prevent migration of water through the pipe bedding zone. The Construction Project Manager may specify alternate locations from those shown in the plans. Concrete cut-offs are the preferred installation method. Refer to Wastewater Management Division Standard Detail S-301.1 figure 2 for typical locations and additional information.

End of Specification



CITY AND COUNTY OF DENVER
ENGINEERING DIVISION

Wastewater Capital Projects Management Standard Construction Specification

5.0 Bedding and Backfilling

5.0.1 General

This section outlines the guidelines and requirements for pipe bedding and backfilling operations required to complete construction per the Contract Documents.

5.0.2 Pipe Bedding

Unless specified otherwise on the Drawings or elsewhere in the Contract Documents, or directed otherwise by the Construction Project Manager, the Contractor shall bed all conduit according to the Class B Bedding method using a crushed granular, mineral aggregate material as noted in these Standard Construction Specifications and install the required geotextile over the pipe and/or bedding. Substitutions of recycled materials or manufactured materials in place of mineral aggregate mixtures for pipe bedding will not be allowed. If, in the course of construction, it is determined that the pipe foundation is unsatisfactory or the prescribed maximum allowable trench width is exceeded, the Construction Project Manager may require that an alternate class of bedding be installed. The Contractor shall be required to place the improved bedding class or make other remedies, at his/her expense.

No separate payment will be made for placement of the required bedding material. All costs incurred will be considered to be included in the unit price bid for each section of sewer line, associated structures, laterals and appurtenances.

5.0.2.1 Bedding Materials

1. #67 Bedding

This bedding shall consist of a durable crushed granular material with a well graded mineral aggregate mixture, which will provide good stability. This bedding shall not contain recycled or manufactured materials. The size range of the aggregate shall be from 1/4-inch minimum to 3/4-inch maximum with a maximum amount of fines passing a No. 8 sieve not to exceed 5% by weight and shall conform to ASTM C-33 or ASTM D-448, gradation size #67. At least 50% of the material greater than the 3/8-inch sieve shall contain particles having 3 or more fractured faces.

CLASS 67 GRADATION	
Nominal Size	Percent Passing by Weight
¾	90-100
⅜	20-55
No. 4	0-10
No. 8	0-5

2. Special Bedding Material

Special bedding material shall only be used where required within the Contract Documents and as specifically approved by the Construction Project Manager. This material is intended for use on rigid pipe of sixty (60) inches or greater in diameter and shall not be used with flexible conduits. Additionally, this bedding shall not contain recycled or manufactured materials. The following gradation requirements shall apply:

SPECIAL BEDDING MATERIAL	
Nominal Size	Percent Passing by Weight
¾	100
No. 4	80-100
No. 16	35-65
No. 50	10-25
No. 100	5-10
No. 200	3-8

3. Alternate Classes of Bedding

Alternate classes of bedding may be required within the Contract Documents or requested within the project scope. All such bedding materials must be submitted and separately approved for use by the Construction Project Manager. Recycled or manufactured materials will not be considered and alternate bedding materials used on site which have not been approved shall be rejected and the removal and replacement of these materials will be at the Contractor's expense.

5.0.2.2 Bedding Requirements

On rigid pipe of fifteen (15) inches or less in diameter and on all pipe classified as flexible, the bedding shall be continued until the bedding is filled to one foot above the top of the pipe. On rigid pipes eighteen (18) inches or greater in diameter, the bedding can be terminated at a point equal to the spring line of the pipe.

Conduit Type	Bedding Requirements*	
	≤15" Diameter	≥18" Diameter
Reinforced Concrete Pipe (RCP, HERCP, etc.)	1' Above Top of Pipe	Spring Line of Pipe
Reinforced Polymer Mortar Pipe (RPMP)	1' Above Top of Pipe	
Ductile Iron Pipe (DIP)	1' Above Top of Pipe	
Corrugated Metal Pipe (CMP, CSP, ASP, etc.)	1' Above Top of Pipe	
Polyvinyl Chloride Pipe (PVC)	1' Above Top of Pipe	
High Density Polyethylene Pipe (HDPE)	1' Above Top of Pipe	
Reinforced Concrete Box Culvert (RCB or RCBC)	6" Below Outside of Box	
* Based on internal diameter or equivalent internal diameter of conduit		

5.0.2.3 Bedding Methods

1. Class A Pipe Bedding

Class A Bedding shall be defined as that method of bedding by which additional supporting strength of the pipe is attained by supporting the lower part of the pipe with a concrete cradle or distributing trench loads on the upper portion of the pipe by means of a concrete arch.

In those instances where Class A Bedding is required, the Contractor shall construct either a concrete cradle or concrete arch as specifically noted in the Contract Documents or as directed by the Construction Project Manager. Class A Bedding shall be constructed of non-reinforced concrete with a minimum 28-day compressive strength (f'_c) of no less than 2000 psi, unless otherwise noted. Additional requirements for either type of construction are specified below. Class A Bedding will normally not be allowed for flexible type installations such as corrugated steel pipe, plastic pipe, etc.

After concrete cradle or arch bedding has been constructed, no backfilling shall be completed above the pipe until the concrete has attained the required minimum compressive strength. Where sheeting is removed or left in place, all cavities remaining, adjoining and/or behind shall be firmly filled with a suitable backfill material.

a. Concrete Cradle

This method of Class A Bedding construction shall consist of bedding the lower part of the pipe in a poured-in-place concrete cradle. The minimum thickness of concrete under and around the conduit shall not be less than that specified on the most recent edition of the Wastewater Management Division Standard Detail Drawings.

The concrete shall extend upward around the pipe a minimum distance of ¼ of the outside diameter (but not less than 4-inches), measured from the lowest portion of the pipe exterior. The width of the concrete cradle shall be at least equal to the outside diameter plus 8-inches. Blocking material required to support the pipe prior to placement of concrete shall have a minimum compressive strength of 2000 psi. The remaining excavation to a point two (2) feet above the top of pipe shall be backfilled and compacted in accordance with Backfill Method B as specified in Section 5.0 of the Standard Construction Specifications.

b. Concrete Arch

This method of Class A Bedding construction shall consist of bedding the upper part of the pipe in a poured-in-place concrete arch. The minimum thickness of concrete over and around the conduit shall not be less than that specified in the most recent edition of the Wastewater Management Division Standard Detail Drawings.

The concrete shall extend upward around the pipe a minimum distance of ½ the outside diameter plus 4-inches, measured from the spring line of the pipe. The width of the concrete arch shall be at least equal to the outside diameter plus 8-inches. Where a concrete arch is required, the lower portion of the pipe (from spring line down) shall be bedded with Class B bedding, in accordance with this section. The remaining excavation to a point two (2) feet above the top of pipe shall be backfilled and compacted in accordance with Backfill Method B as specified in Section 5.0 of these Standard Construction Specifications.

2. Class B Pipe Bedding

Class B Bedding shall be defined as that method of bedding in which the pipe is set on an approved granular material. The trench shall be excavated to a depth below the bottom of the pipe as specified in the Wastewater Management Division Standard Details. The overexcavation shall be backfilled and compacted with a clean granular material free from organic and/or unsuitable materials. The material shall be placed under the pipe and on either side of the pipe up to depths specified within these Standard Construction Specifications. The placing shall be done in a manner which will assure no separation or change in uniform gradation.

All bedding material shall be placed under the pipe haunches, then brought up in six inch (6”) lifts (maximum) and compacted by hand operated mechanical vibrators equally and thoroughly along each side of the pipe in such a manner as to avoid displacement of, or damage to the pipe. All bedding material shall be compacted to a density of at least ninety percent (90%) as determined by the Modified Proctor Method, AASHTO designation T-180, before the next lift is placed. Refer to Wastewater Management Division Standard Detail S-301.2 for additional information.

In no case will jetting or flooding be allowed as means for consolidation or compaction of the bedding material. Cut-off walls will be required to be installed as described in

these Standard Construction Specifications and as shown on the Wastewater Management Division Standard Details.

5.0.3 Backfill

Excavated material will be considered suitable for backfill purposes, provided its use results in a well-compacted stable condition. All backfill material shall be free from rubbish, organics, frozen material, broken pavement, debris, stones larger than three (3) inches in diameter, or other unsuitable materials.

Material having a plasticity index greater than twenty (20) shall not be used for backfill within a street, roadway, or any other area where the degree of compaction is critical. It may be necessary for the Contractor, at his/her sole expense, to dry, wet, mix or otherwise rework satisfactory excavated material as necessary to obtain conformance with these Standard Construction Specifications.

The use of squeegee material or pea gravel will not be allowed as backfill material due to their free flowing nature if undermined. These materials may be used as pipe bedding if required by a specific utility owner, but they must be consolidated by vibration prior to backfilling operations.

When, in the opinion of the Construction Project Manager, the excavated material is unsuitable for use as backfill, or when there is a shortage of satisfactory backfill material within the project limits, the Contractor shall locate and furnish all necessary suitable backfill material and shall dispose of the unacceptable material. All excess backfill or unacceptable excavated material shall be disposed of off the rights-of-way and public property by the Contractor, unless directed otherwise by the Construction Project Manager. Backfilling shall be performed in strict conformance with these Standard Construction Specifications.

5.0.3.1 Trench Backfill

The entire area from pipe subgrade to the finished surface elevation shall make up the trench backfill zone. This zone consists of two (2) main sections described below: the Bedding Trench and the Backfill Above Bedding Trench. All areas outside of this zone will be considered Backfill Outside the Trench.

Unless otherwise set forth in the Contract Documents, the cost of the bedding and trench backfill requirements shall be included in the associated unit price bid for the respective sewer line, associated structures, laterals and appurtenances.

1. Bedding Trench

The Bedding Trench is defined as starting at the subgrade of the specified overdepth required to accommodate the particular class of bedding below the bottom of the pipe and extends vertically to a point where the bedding is terminated (as defined under Bedding Requirements above).

The bedding trench shall be backfilled with an approved bedding material, in accordance with Class A or Class B Bedding methods immediately after the pipe is laid, except where the pipe must remain exposed for leakage tests (subject to the provisions of these Standard Construction Specifications).

2. Backfill Above Bedding Trench

Backfill Above the Bedding Trench shall be considered as starting one foot above rigid pipe fifteen (15) inches in diameter or less and for all pipe classified as flexible; or at the

spring-line for rigid pipe eighteen (18) inches and larger in diameter. All material below these areas shall be considered as bedding material. Refer to the Bedding Requirement table included within this section for further clarity based on pipe types.

3. Backfill Outside the Trench

All backfilling required during construction which is outside of the Trench Backfill Zone, as defined above, will be considered Backfill Outside the Trench. These materials shall meet the requirements set forth in this specification.

Backfill for cast-in-place or precast structures and appurtenances, including but not limited to: manholes, transition structures, junction structures, vaults, inlets and concrete box culverts, shall start at the subgrade for the structure, or appurtenance. As a minimum requirement all structures, inlets, manholes and appurtenances will follow Method B backfill procedures as described in this specification. All remaining operations which fall under Backfill Outside the Trench will follow method A backfill procedures as a minimum, unless specified otherwise in the Contract Documents or directed by the Construction Project Manager.

5.0.3.2 Backfilling Methods

After the specified pipe bedding has been placed, compacted and approved, and after the requirements for the bedding trench have been fulfilled and the Construction Project Manager has approved the commencement of backfilling operations, the balance of the trench shall be backfilled and compacted in accordance with one of the methods described below. The contractor shall not temporarily backfill trenches and return later to re-excavate and meet the backfill method requirements. The Contractor shall consider the minimum backfill and compaction requirements to be in conformance with Backfill Method A for pipeline trenches and Backfill Method B for pipe bedding, backfill under or around manholes, structures, inlets, utilities and appurtenances, unless specified otherwise in the Contract Documents.

The use of hand held tools or devices to meet compaction requirements shall be continued around and above the pipe section during the trench backfilling process until a minimum vertical height above the pipe of two (2) feet is reached. Thereafter, the use of approved compaction equipment (vibratory, sheepsfoot, rubber-tire, etc.) may be utilized. Impact, free fall, stomping and jetting operations are not permitted unless specifically approved by the Construction Project Manager.

The Contractor shall exercise the utmost care during compaction by any of the methods described below, to assure that no damage will occur to the sewer, appurtenances or other existing utilities. Any damage resulting from compaction shall be repaired or replaced at the Contractors expense.

1. Backfill Method A

The backfill shall be placed in horizontal layers of such depths as are specified below for the material being placed and the type of equipment being used. Granular soils shall be compacted by vibration; whereas cohesive soils shall be compacted by a kneading action.

Material for mechanically compacted backfill shall be placed in lifts, which, prior to compaction, shall not exceed the thickness specified below for the various type of equipment:

- a. Vibratory equipment, including vibratory plates, vibratory smooth-wheel rollers, and vibratory pneumatic-tired rollers - maximum lift thickness of two (2) feet;
- b. Rolling equipment, including sheepsfoot (both vibratory and non-vibratory), grid, smooth-wheel (non-vibratory), pneumatic-tired (non-vibratory), and segmented wheels-maximum lift thickness of one (1) foot;
- c. Hand-directed mechanical tampers - maximum lift thickness of six (6) inches.

Permission to use specific compaction equipment shall not be construed as guaranteeing or implying that the use of such equipment will not result in damage to adjacent ground, existing improvements, or improvements installed under the Contract Documents. The Contractor shall make his/her own determination in this regard.

It will be the Contractors responsibility to maintain a minimum of eighty-five (85%) density from the top of bedding to a distance of two (2) feet over the top of pipe. The density from two (2) feet over the top of pipe to the subgrade surface shall maintain a minimum of ninety percent (90%) density. Regardless of facility depth, the last foot of subgrade material shall be compacted to a minimum density of ninety percent (90%). All densities shall be determined by the Modified Proctor Method, AASHTO Designation T-180. Each lift of backfill material shall have the proper moisture content and consistency to permit compaction to the designated density. The compacted material may be tested at any time for adherence to these Standard Construction Specifications.

2. Backfill Method B

This method of backfilling requires placement in six (6) inch lifts. Each lift will have the proper moisture content and consistency to permit compaction to the prescribed density. Each lift will be uniformly and completely compacted by either handheld pneumatic or mechanical tampers to a density of at least equal to ninety percent (90%) of the density determined by the Modified Proctor Method, AASHTO designation T-180, before the next lift is placed.

3. Backfill Method C

Other methods of backfill placement and compaction to the prescribed density may be submitted to the Construction Project Manager by the Contractor. These methods will not be used without the prior written approval of the Construction Project Manager.

5.0.3.3 Select Backfill Materials

Select materials shall only be used as backfill when specifically shown in the Contract Documents or as approved and authorized by the Construction Project Manager and will only be placed to the specified depths in those areas as shown on the Contract Documents or as ordered by the Construction Project Manager. The materials listed here are only intended for backfilling purposes and shall not be used for pipe bedding at any time. Prior to using select materials onsite, the Contractor shall submit product documentation for approval. All select material placed without approval from the Construction Project Manager will be rejected and the Contractor will incur all costs associated with removal and replacement of the material.

1. Subgrade Material (Select Backfill)

Select subgrade material, which may also be specified as “select backfill material” in other locations within the Contract Documents, shall be defined as a well graded mixture of sound mineral aggregate particles containing sufficient, proper quality binding material to secure a firm, stable foundation when placed and compacted. When tested with laboratory sieves, the material shall meet the following gradation requirements:

Standard Sieve Size	% Passing (by Weight)
3 inch	100
No. 10	80 maximum
No. 200	0-15 maximum

All select subgrade material shall be of such quality that material passing a No. 40 sieve will have a liquid limit of not more than thirty five (35) and a plasticity index of not over six (6) when tested in conformity with AASHTO Designations T-89 and T-91 respectively. In addition, the City will take soil-bearing tests where necessary, to evaluate the quality of materials produced from pit sources. If the bearing value or stabilometer values of pit materials are considered to be adequate, minor deviations (less than five percent) from the liquid limit and plasticity index criteria specified shall not be considered to be a basis for rejection of the material. It shall be the responsibility of the Contractor to locate material meeting these Standard Construction Specifications and to secure approval of the Construction Project Manager before such material is delivered to the project. If at any time during the construction, such tests reveal that the material being delivered is not of suitable quality for the purpose for which it is intended, the City reserves the right to direct the Contractor to change pit locations as necessary, at no cost to the City. If the Contractor so elects, he/she may, at his/her own expense, remove and dispose of the excavated material even if the Construction Project Manager considers it satisfactory for use as backfill, and replace it, at his/her own expense with select backfill material.

2. Structural Fill

Structural Fill shall be defined as a well graded mixture of sound mineral aggregate particles void of debris containing sufficient proper quality binding materials to secure a firm, stable foundation when placed and compacted. When tested with laboratory sieves, the material shall meet the following gradation requirements:

Standard Sieve Size	% Passing (by Weight)
2 inch	100
No. 4	30-100
No. 50	10-60
No. 200	5-20

Bearing value and or stabilometer tests by CBR or R value methods may be required to properly evaluate the quality of the material.

Colorado Department of Transportation approved class 4, 5, or 6 base course materials typically meet the above specifications. A report showing the gradation analysis and test results for the materials proposed for Structural Fill shall be required by the Construction Project Manager prior to placement and in accordance to AASHTO designations T-89 and T-91.

3. Recycled and Processed Materials

Recycled and processed materials shall include: recycled concrete, aggregates, asphalt, crushed gravel base course (road base), crusher fines or any other materials specified as such. The use of these materials within the construction site shall be limited to those areas designated within the Contract Documents or approved by the Construction Project Manager.

The following gradations are provided as a guideline for recycled and processed materials commonly used in construction and represent only a portion of those available for use. Approved submittals will be required prior to placement, to ensure that the material type and particle distribution are suitable for the intended application. All materials of this category placed without previous approval of the Construction Project Manager shall be rejected and all costs incurred for removal and replacement of these materials will be at the Contractor's expense.

a. Crushed Recycled Concrete

Standard Sieve Size	% Passing (by Weight)
1½ inch	100
¾ inch	40-75
¼ inch	25-50
No. 40	5-20
No. 200	10 max

b. Crushed Recycled Asphalt Pavement

Standard Sieve Size	% Passing (by Weight)
1½ inch	100
¾ inch	40 minimum

c. Crushed Gravel Base Course (CDOT Class 6 Road Base)

Standard Sieve Size	% Passing (by Weight)
¾ inch	100
No. 4	30-65
No. 8	25-55
No. 200	3-12

d. Crusher Fines

Crusher fine material shall meet the gradation shown in the following table. The material shall consist of fine mineral fragments resulting from rock crushing operations.

Standard Sieve Size	% Passing (by Weight)
¾ inch	100
No. 4	90-100
No. 8	55-80
No. 16	40-70
No. 30	25-50
No. 200	6-15

4. Controlled Low Strength Material (CLSM)

Controlled Low Strength Materials (CLSMs) consist of a well-graded mixture of mineral aggregates, cementitious materials, water and admixtures. Other common names for CLSMs include: flowable fill, flowfill, non-shrink backfill, fly ash fill and controlled density fill.

The contractor will be required to submit a mix design and test data to the Construction Project Manager for approval, prior to excavating the area for which CLSMs are proposed for use. All materials of this category placed without previous approval, or which do not perform as specified, will be rejected by the Construction Project Manager and all costs incurred for removal and replacement of these materials will be at the Contractor's expense.

All CLSMs shall adhere and conform to the following, unless noted otherwise:

- a. The mix must be capable of freely flowing to fill all voids in trenches or other areas without compaction or other additional effort,
- b. The mix must be of uniform density and low permeability to prevent migration of adjacent fines into the set mix,

- c. Must be placed in a uniform manner that will prevent voids or segregation of the backfill and shifting of pipelines, structures and appurtenances. Foreign material that falls into the trench prior to, or during placement shall be immediately removed,
- d. The CLSM shall be produced using a central-mixed concrete plant or other approved method,
- e. Chemical admixtures containing chlorides shall not be used unless approved otherwise,
- f. CLSMs will be classified as either Standard Aggregate or Fine Aggregate CLSM according to the table below. Submitted CLSMs must follow the gradation guideline provided here, unless approved otherwise:

Standard Sieve Size	% Passing (by Weight)
1 inch (For Standard Aggregate CLSM)	100
3/8 inch (For Fine Aggregate CLSM)	100
No. 8	50 minimum
No. 200	0-30 maximum

- g. The 28-day compressive strength must be between 50 and 150psi, unless otherwise directed by the Construction Project Manager. Test cylinders may be required to insure that the specified strength is obtained. The compressive strength shall be determined by ASTM D4832, "Preparation of Testing of Soil-Cement Slurry Test Cylinders",
- h. The mix shall have a slump between 7 and 10 inches as per AASHTO Designation T 119-82,
- i. When CLSMs are placed within the right-of-way, or they are to be covered by paving materials, the final set product must achieve a maximum indentation diameter of 3-inches prior to covering and opening the area to traffic. Penetration resistance shall be as measured by ASTM C6024, "Standard Test Method for Ball Drop on Controlled Low Strength Material to Determine Suitability for Load Application",
- j. Final set product shall excavate easily, minimizing the risk of damage to buried utilities during future work,
- k. Must be placed within 2 hours after mixing at the batch plant, unless otherwise approved or specified by the Construction Project Manager,
- l. Delivery tags shall be collected from the delivery driver and provided to the Project Inspector or Construction Project Manager. The delivery tag shall contain the supplier name, the mix identifying name and/or number as listed in the supplier's submitted mix design. The Project Inspector or Construction Project Manager may reject any mix that does not appear to meet the requirements of this specification (segregation, insufficient slump, open graded aggregates, etc.).

5. Topsoil

Topsoil shall be defined as soil that contains the sufficient organic materials necessary to support growth of grass, which is free of all types of debris, weeds, stones or other unsuitable materials. Topsoil will be required to be placed and compacted whenever excavation occurs through parks or other landscaped areas and the excavated material is deemed to be unsuitable for growth. Placement will be required from the existing subgrade to the depth specified in the Contract Documents or as otherwise directed by the Construction Project Manager. All topsoil used within the construction site shall conform to the Contract Documents and/or the specifications set forth by the owner of property affected during construction. Topsoil may also be specified as Class B Topsoil.

Class B topsoil shall be the original top layer of the soil profile formed under natural conditions, technically defined as the "A" horizon by the Soil Society of America. It shall have demonstrated by evidence of healthy vegetation growing or having grown on it, prior to stripping, that it is well drained and does not contain substances toxic to plant life. It shall be the responsibility of the Contractor to locate material meeting these Standard Construction Specifications and to certify that the material is suitable for the intended purpose. The contractor must also secure approval of the Construction Project Manager before such material is delivered to the project.

Topsoil shall not be placed until the areas to be covered have been properly prepared and grading operations in the area have been completed. Topsoil does not require compaction but shall be keyed to the underlying material by the use of rollers or other equipment suitable for the purpose. Water shall be applied to the surface in a fine spray by nozzles or spray bars in such a manner that the operation does not wash or erode the topsoil areas.

6. Other Classified Select Materials

Alternate select materials, stabilization materials, and angular rock bedding materials shall be considered as other classified select materials.

Whenever the excavated material is deemed to be unsuitable for backfill and there is no requirement for the placement of any of the above specified select materials, other classified select materials shall be placed and compacted. It shall be the responsibility of the Contractor to locate such material and to secure written approval of the Construction Project Manager before such material is delivered to the project.

5.0.3.4 Unsuitable Material

Unsuitable material encountered within the project boundaries during construction shall be excavated and disposed of by the Contractor. Unsuitable material is defined as:

1. Soil and excavated material containing debris, weeds, asphalt, stones or concrete (larger than 3-inches in diameter), rubbish, and frost or other frozen particles,
2. Material determined to be of such an unstable nature as to be incapable of being compacted to the specified density using ordinary methods, at optimum moisture content,
3. Material which is too wet to be properly compacted and circumstances prevent suitable in-place drying prior to incorporation into the work,
4. Material otherwise unsuitable for the planned use per the Contract Documents.

5. Any fill material or soils not meeting regulatory and City standards for contamination

The presence of excessive moisture in a material is not, by itself, sufficient cause for determining that the material is unsuitable. Additionally, material which becomes unsuitable due to negligence or the means and methods utilized by the contractor will not be considered for payment. The costs incurred to remove and replace these materials shall be included in the associated unit price bid for the respective sewer line, associated structures, laterals and/or appurtenances.

The cost of removal of unsuitable backfill material and replacement with suitable material encountered while completing the project scope and which do not meet the above, will be paid for per the applicable bid items and in accordance with the associated measurement and payment description.

End of Specification



CITY AND COUNTY OF DENVER
ENGINEERING DIVISION

Wastewater Capital Projects Management Standard Construction Specification

6.0 Surface Restoration

6.1 General

Where pavement, curb and gutter, sidewalks, drainage culverts, headwalls, or other structures or improved surfaces, landscaping, etc., have been removed during the course of the work, such items shall be restored to a condition at least equal to that prior to removal and to the same elevation and alignment. The subgrade for all restored surfaces shall be thoroughly compacted to the specified limits by mechanical or hand tampers.

6.2 Asphalt Replacement

Except as modified herein, asphaltic concrete paving material to be replaced over trench excavations shall conform to the MGPEC asphalt paving requirements.

6.2.1 Thickness

Unless otherwise stipulated in the **Proposal** or on the Plans, all asphalt pavement required to be removed for trench or structural excavation shall be replaced with a "full depth" asphaltic concrete paving section conforming to the depths specified on the Plans.

6.2.2 Materials

The materials to be used for asphaltic concrete pavement shall conform to **Item 20** of the **Standard Construction Specifications** and the herein described modifications, additions or deletions.

6.3 Gravel Surfaced Streets and Alleys

Where excavation occurs in streets, alleys, or other areas which have only a gravel surface, such surfacing shall be replaced with gravel surfacing material equal in depth to that which existed before construction but not less than 3 inches compacted depth minimum. The surface shall conform to the original finish grade.

If the Contractor so elects, the existing gravel surfacing may be excavated down to a depth and width designated by the Project Construction Engineer, stockpiled in an area separate from the excavated trench material, and later replaced to the required depth after the trench has been properly backfilled.

No separate measurement for payment will be made of any work or material stipulated above that is necessary to remove and later replace the gravel surfacing, and all costs incurred will be considered to be included in the unit price bid for the construction of the appropriate section of sewer line or the associated structure.

6.4 Sidewalk, Curb and Gutter, Concrete Pavement

Where sidewalks, curb together, culverts and other obstacles are removed in the prosecution of the work. The Contractor shall consolidate the backfill in the same manner as specified for paved streets and shall then replace sidewalks curb and gutter, etc. in accordance with standard specifications for class of work involved. Where sod areas are encountered, the sod shall be removed and replaced with new at the original grade and elevation after consolidation of the backfill. Sprinkler systems shall be protected or removed and replaced as required.

6.5 Sod

Sod, defined as densely grassed turf, which is removed, may be put back if it has been properly stored and remains in a healthy condition. If so stipulated in the Contract, the cost of replacing sod will be paid in the manner described under Measurement and Payment. If no pay item for replacing sod is included in the Contract, the Contractor shall consider that all costs incurred in replacing sod are to be included in the unit price bid for each section of sewer line or the associated structure.

6.6 Concrete Alley Pavement Replacement

Except as modified herein, concrete alley pavement replacement over trench excavations shall conform to **Item 4** of the **Standard Construction Specifications**.

6.6.1 Materials

The materials to be used for concrete alley pavement replacement shall conform to Item 20 Grass Sodding and the herein described modifications, additions or deletions.

- a. **Wire Mesh.** Reinforcing steel (6" x 6", W1.4 x W1.4) wire mesh shall be used for reinforcement of the concrete pavement over For replacement of full width alley concrete paving, the reinforcing steel wire mesh will extend the full alley width, per Wastewater Management Division Standard Detail S-205.
- b. **Concrete Aggregates.** Concrete shall conform to Paragraph 12.2, "materials", subparagraph b(2) of the Standard Specifications.
- c. **Joint Sealer.** Silicone joint sealer shall be a one part, low modulus, silicone formulation, designed for use in highway joint sealing applications and meeting Federal Specifications TT-S-001543A and TT-S-00230C. Primer shall be used if required by the manufacturer.

Acetic acid cure sealants are not acceptable.

Test methods shall be as follows:

Flow	MIL S 8802
Extrusion Rate	MIL S 8802

Track Free Time	MIL S 8802
Specific Gravity	ASTM D 792, Method A
Durometer Hardness	ASTM D 2240
Tensile Stress	ASTM D-412 (DIE C)
Elongation	ASTM D-412 (DIE C)
Ozone & Resistance	ASTM D-793-75

Bond to concrete mortar: Briquettes molded in accordance with AASHTO T 132-74 sawed in half and bonded with a thin section of sealant and tested in accordance with AASHTO T 132-74. Briquettes shall be dried to constant weight in oven at 110 degrees C+ degrees.

GESCS4403 Highway Joint Sealant and Dow Corning 888 Silicone Joint Sealant are approved for sealing joints. "Backer Rod" used in joints for Portland Cement Concrete Pavement shall be closed cell, polyethylene form rod conforming to the following specifications:

Diameter	Joint width + 1/78"	
Density	2.0 lbs./cu. ft.	ASTM D-1622
Tensile	15 psi	ASTM D-1623
Water Absorption	0.5% by volume	ASTM C-509
Compression Reflection	25% @ 8 psi	ASTM D-1621

6.6.2 Construction Requirements

a. Alley Paving.

"Concrete driveways which abut the alley must be placed separately, creating a cold joint between the concrete driveway and the alley for the full depth of the alley paving."

b. Expansion Joints.

"Expansion joints shall be placed at the end of block property lines and where the alley changes directions. Construction of the expansion joints will be as shown on the Wastewater Management Division Standard Details. Expansion joints shall also be required at structures, vaults, retaining walls, poles, etc. or as required by the Project Construction Engineer."

c. Dummy Groove Contraction Joints. The Contractor has the option to use the dummy groove contraction joints as follows:

"All contraction joints will be saw cut as shown on the Wastewater Management Division Standard Details. The saw cut will be 1-1/2 inches deep by 3/8 inch minimum width to a maximum of 1/2 inch for the full width of the alley. Contraction joints will be spaced a maximum of fifteen (15) feet apart along the length of the alley and must be sawed consecutively in the direction of the pour. Only by approval of the Construction Project Manager may a joint be skipped and sawed later. Transverse contraction joints shall be placed at each utility pole, manhole, and at the ends of retaining walls, or as directed by the Project Construction Engineer. Contraction joints shall extend through any alley

curbhead. Concrete joint sealer shall be a grey silicone joint sealant as manufactured by G.E., Dow-Corning or an approved equal. All joint sealers and backer rods shall be installed in accordance with the manufacture's requirements. The silicone shall meet all applicable AASHTO, ASTM and Federal Specification TT-S-0021543A and TT-S-00230C.

Saw cut joints to be sealed shall be filled with joint sealing material before the pavement is opened to traffic and as soon after completion of the curing period as is feasible. Just before sealing, each joint shall be thoroughly cleaned of all foreign material, including membrane curing compound, and joint faces shall be clean and surface-dry when seal is applied. Where cleaning of the joints is by compressed air, the compressed air shall be oil free. The sealing materials shall be applied to each joint opening in accordance with the details shown in the plans, to the manufacturer's specifications or as directed by the Project Construction Engineer. The joint filling shall be done without spilling material on the exposed surfaces of the concrete. Any excess material on the surface of the concrete pavement shall be removed immediately and the pavement surface cleaned. The use of sand or similar material to cover the seal shall not be permitted. Joint sealing material shall not be placed when the air temperature in the shade is less than 50 degrees F., unless approved by the Project Construction Engineer.

Should other cleaning methods prove unsatisfactory, the Construction Project Manager may require sandblasting or another method inside of the contraction joints to remove incompressible materials. The Contractor may wish to install the backer rod on top of the sawed joint in order to keep it clean and later depress the rod when the silicone sealant is installed. The joints shall be sealed by first priming the joint, if required by the silicone sealant manufacturer and then placing a backer rod compatible with silicone and sealing with an approved liquid silicone joint sealant. The joints should be approved by the Construction Project Manager prior to sealing."

- d. **Opening to Traffic.** Add the following after the first sentence of Paragraph 35.3I: "Or until field-cured concrete cylinders have obtained a compressive strength of 3500 psi and all contraction joints have been cleaned and sealed."
- e. **Raised Lips.** No extra payment will be made for raised slope paving required to widen alleys to meet existing improvements shall be paid for as Concrete Alley Paving.
- f. **Finish.** As shown the plans, or where longitudinal slopes exceed 7%, or where required by the Project Construction Engineer, a 3/16 inch metal time finish shall be applied perpendicular to the centerline in accordance with Colorado Department of Highway specifications.

End of Specification



CITY AND COUNTY OF DENVER
ENGINEERING DIVISION

Wastewater Capital Projects Management Standard Construction Specification

7.1 TUNNELING, JACKING AND BORING

7.1.1 Definitions

7.1.1.1 Geotechnical Data Report (GDR)

A document which presents an interpretation of the known subsurface data for the project. The purpose of the GDR is to compile all geological, geotechnical, groundwater, and other data obtained from the geotechnical investigations for use by the various participants in the project. If available, this information will be included within the contract documents as specifically applicable to the project.

7.1.1.2 Geotechnical Baseline Report (GBR)

The intent of a GBR is to clearly and contractually define the geotechnical conditions through which tunneling will occur in order to evaluate a differing site condition (if encountered) and it is used as a basis of bid for the contractor. By assessing the anticipated geotechnical conditions for a project and providing baselines in the contract, the contractor has a basis from which to prepare their bid and select their means and methods. The baseline conditions do not necessarily reflect the actual conditions; they are not geotechnical fact to be encountered. Rather, they represent the owner's assumption of existing geotechnical conditions for the project. If available, **this** information will be included within the contract documents as specifically applicable to the project. Regardless of inclusion, this information shall be investigated, interpreted, verified and/or developed by the contractor prior to commencement of the work.

7.1.1.3 Tunnel Shield

A circular steel shell shaped to fit the excavation line of the tunnel that provides protection for the construction personnel and space for the tunnel excavation and support operations. The shield may be fitted with boom-mounted tools such as an excavator for excavating the tunnel and mechanical devices for erecting the tunnel supports, or hand mining may be performed inside the shield.

7.1.1.4 Tunnel Boring Machine (TBM)

A machine that uses a full-face cutter head to excavate a circular tunnel.

7.1.1.5 Pipe Jacking

The one-pass trenchless installation of a pipe by jacking the pipe behind a TBM or Tunnel Shield.

7.1.1.6 Permeation Grouting

The direct pressure injection of a chemical fluid grout into the ground to fill the spaces between and bind together soil particles, without causing excessive movement or fracturing of the soil formation. Permeation grouting is performed prior to commencement of tunneling operations to provide a more consistent and stable soil matrix. If applicable, the general extents of permeation grouting for a specific project may be shown in the plans.

7.1.1.7 Compensation Grouting

Compensation grouting is a grouting technique utilized to control ground settlement during soft ground tunneling. Compensation grouting involves the injection of a low slump mortar-like grout under high pressure to compact and displace the adjacent soils. The grout does not penetrate soil pores but displaces the subsurface soils by forming a homogeneous grout bulb near the grout pipe tip. Typically, compensation grouting is done after completion of tunneling to correct for settlement. Compensation grouting may also be performed concurrently with the progress of the tunnel while adjusted grouting parameters continually with reference to measured movements of the ground and/or surface structures, to keep settlement and deformations within specified limits.

7.1.1.8 Contact Grouting

The controlled injection of fluid grout at the interface between the pipeline and the ground to achieve continuous contact and fill the annular space, after pipe jacking has been completed.

7.1.1.9 Inclinator

An electronic probe lowered within a casing that senses changes in inclination along the casing axis. Inclinator are used to record the magnitude and depth of horizontal ground displacement. For tunneling purposes, they are typically installed adjacent to pit locations.

7.1.1.10 Surface Monitoring Point

A marker or point fixed to the ground surface and/or structures along a proposed alignment that is monitored by a professional land surveyor licensed in the state of Colorado using survey control to determine vertical and/or horizontal displacements that may occur during construction.

7.1.1.11 Surface Monitoring Point Array

A grouping or arrangement of surface monitoring points along the proposed tunnel alignment to determine vertical and/or horizontal displacements that may occur during construction.

7.1.1.12 Deep Settlement Monitoring Point

A sleeved rod installed to a specific depth, above the crown of the tunnel, which is used to detect ground movement directly above the tunnel. Also referred to as a single-point fixed

borehole extensometer or Borros anchor.

7.1.2 Section Includes

This item includes construction via tunneling, jacking and/or boring as shown on the Construction Drawings. The work includes: excavation of the tunnel, installation of carrier pipe, pipe, contact grouting around the pipe after tunneling, installation and monitoring of geotechnical instrumentation, disposal of excavated soils and compensation grouting as necessary during tunneling operations to control settlement to within acceptable limits. If the need for permeation grouting prior to starting the tunneling is anticipated, a separate bid item will be included within the contract documents.

7.1.3 Requirements

The Contractor must adhere to all requirements contained with the Contract Documents, as well as access permits between the City and facility owners within the project limits.

A pre-excavation permeation grouting program shall be implemented prior to beginning tunnel excavation to improve ground behavior and reduce the potential for ground loss during tunneling. Requirements for this program are provided within these Standard Construction Specifications.

The Contractor shall determine tunneling and support equipment, materials, and methods subject to the limitations specified herein and elsewhere in the Construction Documents. It is the responsibility of the Contractor to safely construct the tunnel and provide the finished product within the requirements specified and shown. The Contractor shall design his tunnel means and methods to allow for performance of the work as specified herein.

The Contractor shall have the sole responsibility for maintenance and protection of existing utilities, railroad tracks, structures, and facilities within the zone of construction. Location of utilities shown on the Construction Drawings shall be considered approximate. The Contractor shall be responsible for locating each utility potentially impacted by the work to verify location prior to beginning the tunneling work.

The Contractor shall allow the Engineer, the City's Construction Project Manager, and the City's Project Management Team access to the shafts and tunnel.

7.1.4 Submittals

7.1.4.1 Preconstruction

Submit the following a minimum of 8 weeks prior to mobilization of tunneling equipment to allow for review by the City's Construction Project Manager and any other affected project stakeholders:

1. A detailed work plan including descriptions of methods and equipment to be utilized in completing the work, schedule for tunnel construction, and details of proposed tunnel construction procedures.
2. A detailed scale drawing showing tunnel layout, shaft locations and dimensions, and staging areas.

3. Procedures for measuring excavation quantities versus forward progress during the tunneling operation.
4. A description and drawings of proposed methods and procedures for excavating the tunnel, including details for tunnel shield or TBM, breasting capabilities, method of controlling line and grade of the tunnel, and steering provisions for making line-and-grade corrections. Include details of provisions for supporting the face of the tunnel when tunneling operations are interrupted.
5. Contact grouting plans and procedures including: description of the grout system and grout equipment including grout pumps, mixers, delivery systems, and monitoring systems; number and spacing of grout holes; procedures for monitoring grout placement and controlling pressures; sequence of construction; grout material and properties; grout mix design including fluidizers, accelerators, and other additives; grout material properties including density, viscosity, bleeding, shrinkage, expansion, and set time.
6. Work plan and shop drawings showing: jacking frame and thrust block design, layout and details, including reaction transfer calculations. The thrust block backstop shall be normal (square) with the proposed pipe alignment and shall be designed to withstand the maximum jacking pressure to be used with a factor of safety of at least two, without excessive deflection or displacement.
7. Design calculations demonstrating that the pipe is capable of sustaining the maximum stresses to be imposed during jacking with a factor of safety of at least two. The calculations shall take into account: ground loads per the Geotechnical Data Report if available; live loads and surcharge loads from equipment; Cooper E80 loads; and jacking forces. Calculations to be performed and stamped by a professional engineer registered in the State of Colorado.
8. Submittal of a settlement control plan and applicable contingency plans prior to construction, including the proposed locations of surface monitoring points and arrays, deep settlement monitoring points, and inclinometers; equipment and materials to be used; and installation procedures.
9. Five days prior to commencement of grouting or construction of any kind, the contractor shall submit the installed location of all surface monitoring points, deep monitoring points and inclinometers. The Contractor shall submit drawings showing the surveyed location, the instrument identification number, the instrument type, the installation date and time, established elevations, initial elevations, offset and stationing, initial coordinates, boring logs, and the anchor to tip elevation and instrument length, when applicable.

7.1.4.2 During Construction

Written Daily Logs. The Daily Logs shall be recorded for each shift and shall be submitted to the City's Construction Project Manager within one working day of excavation at each location. As a minimum, the logs shall include the following:

- The station of the face of the excavation and advance distance;
- Length of pipe installed;
- The date, starting time, and finish time;
- Any unusual conditions, breakdowns, and delays;
- Excavated muck quantity;
- An accounting of volume of spoil in relation to the lineal foot advancement of the tunneling head
- Contact grouting performed;
- Results of pipe joint pressure testing; and
- Results of instrumentation monitoring.

7.1.5 Materials

7.1.5.1 Tunnel Shield or Tunnel Boring Machine (TBM)

The tunnel shield or TBM shall be designed to sustain ground loads which may be imposed upon it as well as any loads imposed by the thrust jacks, steering mechanisms, and other appurtenances. Tunnel excavation equipment shall be capable of maintaining a stable face in all expected ground conditions. The tunnel shield or TBM shall be steerable and capable of being controlled to the desired line and grade indicated on the Construction Drawings within the tolerances specified herein. Equip the tunnel shield or TBM with a laser control system to permit continuous and accurate monitoring of line and grade. Projections for overcutters, wing cutters, and overcut band, if used, shall not exceed 0.5-inch outside the skin of the tunnel shield or TBM.

The tunnel shield or TBM shall have suitable breasting tables, a closeable cutter wheel with flood doors, or such other appropriate provisions, as necessary, to support the tunnel face and minimize loss of ground. Mechanical or hydraulic excavators shall not interfere with breasting system or face support provisions. Excavator shall be capable of operation when fully retracted within the tunnel shield.

The tunnel shield or TBM shall have a propulsion system capable of moving the shield or machine forward while maintaining the construction tolerances with respect to line and grade. The propulsion system shall include a thrust ring or other provision that will distribute the jacking forces uniformly against the casing or jack pipe so the shield or machine can be advanced without damaging or distorting the pipe.

7.1.5.2 Contact Grout

Contact grout shall be a stable colloidal suspension of cement, bentonite, water, fluidifier, and admixtures. Sand may be added, provided the grout is demonstrated to have suitable flow characteristics and to adequately fill the annular space between the pipeline and the ground being tunneled through.

The grout mix shall be the responsibility of the Contractor. The Contractor shall adjust the water-solids ratio of the grout as necessary to grout effectively and to fill all voids within the zone of grout influence; however, at all times the grout shall have a water-solids ratio of between 1:1 and 3:1 by volume, and a bentonite content of no more than two percent, and no hole shall be completed with a water-solids ratio above 1:1 by weight.

7.1.5.3 Pipe

The pipe to be installed via tunneling shall be indicated within the plans and in accordance with the applicable portion of these Standard Construction Specifications.

7.1.5.4 Casing Pipe, Spacers and End Seals

Where tunneling operations are completed via boring and where specifically called out in the contract documents, a casing pipe, spacers and end seals shall be required.

The casing pipe shall be of welded steel pipe conforming to the requirements of ASTM A53 Grade B or AWWA C200, having minimum yield strength of 35,000 psi of the size and wall thickness as shown below or as otherwise noted in the Contract Documents.

Casing Diameter	Minimum Thickness
36" and Smaller	$\frac{3}{8}$ - inch
42" and Larger	$\frac{5}{8}$ - inch

Casing shall be kept on line and grade as required within this specification. Joints in the casing shall be field welded around the entire joint perimeter to produce a watertight seal. Welds shall be of a size to develop the full strength of the pipe materials.

Factory manufactured casing spacers shall be installed on all carrier pipes passing through a casing pipe. Wooden skids will not be allowed.

All casing spacers shall adhere and conform to the following:

1. All casing spacers shall be Model SSI8 or SSIM (field adjustable) for carrier pipes up to 24-inches in diameter and Model SSI12 for larger diameter carrier pipe sizes as designed and manufactured by Advance Products & Systems, Inc., Lafayette, LA., or an approved equal. The runners shall be at least 7-inches long for SSI8 and SSIM models or 11-inches long for SSI12 models and they shall be manufactured of high abrasion resistant, low coefficient of friction, glass filled polymer.
2. The casing spacers shall be center restrained to limit vertical movement of the carrier pipe in the casing.
3. Casing spacers shall be bolt-on-style with a shell made of at least two halves.
4. Spacing is approximately 3 per joint of pipe or 1 spacer per every 7 feet maximum.

5. The band material shall be manufactured of a minimum 14 gauge T-304 stainless steel and 10 gauge T-304 stainless steel risers when needed.
6. The casing spacers shall have a flexible PVC or EPDM liner having a minimum thickness of 0.090 inches with a hardness of Durometer "A" 85-90.
7. All welds are to be chemically cleaned and passivated.
8. All hardware shall be stainless steel.

After insertion of the carrier pipe into the casing, the ends of the casing shall be closed by installing $\frac{1}{8}$ " thick synthetic rubber end seals such as the Model "AC" pull-on end seal, as manufactured by Advance Products & Systems, Inc., Lafayette, LA, or an approved equal. Ends seals shall be attached using minimum $\frac{1}{2}$ " wide T-304 stainless steel bandings utilizing a worm gear mechanism.

7.1.6 Instrumentation

7.1.6.1 Surface Monitoring Point Array

Surface monitoring points shall consist of a stable non-destructive pin, nail, point, or other identifiable element with the locations clearly identified where the ground surface consists of sidewalk, curb, rail, or other structure. Where the ground surface consists of soil, vegetation, or ballast, the surface monitoring point shall consist of a minimum 1-foot long rebar anchor driven flush with the ground. The anchor shall be grouted in place. Each surface monitoring point shall have a tag or marking indicating the identification number, tunnel station, and offset from centerline.

7.1.6.2 Surface Monitoring Point Array

The surface monitoring point array shall consist of multiple surface monitoring points installed and arranged in accordance with the Contractors submitted and approved work plan, and as outlined within these specifications.

7.1.6.3 Deep Settlement Monitoring Point

Deep settlement monitoring points shall consist of a rebar anchor installed within a casing to a depth of 3 feet above the top of the tunnel, as shown on the Construction Drawings. Each point shall have a tag or marking indicating the identification number, tunnel station, and offset from centerline. Deep settlement monitoring points shall be installed in accordance with the Contractor's submitted and approved work plan and they shall be protected by traffic rated roadway boxes.

7.1.6.4 Incliner

Inclinometers are only required if specifically called out within the contract documents.

If required, they shall consist of inclinometer casing installed and grouted within vertical boreholes in the in situ soil. A probe, lowered within the casing, senses changes in inclination along the casing axis, and is used to calculate and monitor the magnitude and depth of horizontal ground displacements. Inclinometers shall be protected by roadway boxes.

Inclinometer casing shall be approximately 70 mm (2.75 in.) standard flush coupled such as Model No. 51150210 manufactured by Slope Indicator Company, Seattle; or approved equivalent.

Inclinometer Probe and Assembly. One inclinometer assembly shall be furnished including a sensor (probe) on a minimum 100 ft long cable, a pulley assembly, and a case. This equipment shall be Model No. 50302910 (sensor), and associated pulley assembly, and case manufactured by Slope Indicator Company, Seattle, WA or approved equivalent.

Inclinometer Readout Unit. Furnish one inclinometer readout unit. The readout unit shall be model No. 50310900 manufactured by Slope Indicator Company, Seattle, WA or approved equivalent. Readout unit provided shall be compatible with inclinometer probe and shall be calibrated to probe by manufacturer prior to shipment.

Inclinometer Software. Computer software required to reduce, analyze, and plot the inclinometer data using a compatible personal computer (PC) shall be furnished. Furnish Datamate Manager Software supplied by Slope Indicator Company, Seattle, WA or approved equivalent, or software compatible with other approved readout units.

Provide a cement-bentonite grout for installing inclinometer casing within drill hole. Grout mix shall be in accordance with manufacturer's requirements, and shall have up to 20 percent bentonite content by weight of cement; add enough bentonite to create a grout with a Marsh funnel number of 55 seconds.

7.1.7 Commencement of Work

Do not begin tunneling until:

1. Required submittals have been reviewed and approved by the Engineer, applicable utility companies, and stakeholders.
2. A pre-construction meeting with the Engineer, City's Construction Project Manager, City's Project Management Team, applicable utility companies, stakeholders and Contractor has been conducted.
3. Shaft excavation and support have been satisfactorily completed in accordance with the Contract Documents.
4. Permeation grouting has been satisfactorily completed in accordance with the Contract Documents.
5. All instrumentation has been installed and initial measurements have been obtained

7.1.8 General Tunneling Requirements

Conduct all operations such that trucks and other construction vehicles do not create a dust nuisance in the streets and adjacent properties. All work shall be done so as not to disturb railroad tracks, roadways, adjacent structures, landscaped areas, or utilities other than as shown on the Construction Drawings. Any damage shall be immediately repaired to the

satisfaction of the property owner, residents, agency or utility having jurisdiction, and the City at no additional cost to the City.

No gasoline-powered equipment shall be permitted. Diesel, electrical, hydraulic, and air powered equipment is acceptable, subject to applicable City, State, and Federal regulations. There will be no classification for excavated materials and the term "excavation" shall include all materials excavated or removed from the tunnel, regardless of the type, character, composition or condition of the material so excavated.

The tunnel shall be excavated to the lines, grades and dimensions required to ensure installation of the pipeline as indicated on the Construction Drawings. The tunnel excavation shall begin at the downstream end and work upstream unless approved otherwise.

Methods of construction for the tunnel shall ensure the safety of the work, the Contractor's employees, the public, and adjacent property, whether public or private. Perform all work in accordance with all current applicable permit conditions, regulations, and codes of federal, state, and local agencies. Comply with all applicable provisions of 29 CFR Part 1926, Subpart S, Underground Construction by OSHA. Comply with standards and guidelines provided by AREMA, as applicable to the work. In the event of conflict, the strictest or most restrictive shall govern.

7.1.9 Tunnel Construction

Tunnel excavation shall be performed in a manner that will minimize movement of the ground in front of and surrounding the tunnel, and to minimize loss of ground, surface settlement, heave of the ground surface, and movement of railroad tracks, structures, and utilities above and adjacent to the tunnel. The Contractor shall ensure that movement (settlement or heave) at the ground surface does not exceed 0.25-inches, unless noted otherwise within the contract documents.

Support the ground continuously and in a manner that will prevent loss of ground and maintain the stability of the tunnel perimeter and face. Support the tunnel face by positive means during all shut down periods.

Maintain clean working conditions at all times inside the tunnel, and remove all excavated soil (muck), grout spills, and any other material not required for tunneling. All construction debris shall be removed from the site and disposed of daily by the Contractor at the disposal site designated elsewhere in the Construction Documents.

Provide all temporary electrical, water, telephone, and other facilities required to complete the tunnel.

Provide access for Engineer, City's Construction Project Manager and City's Project Management Team to inspect and observe the work or to perform independent line and grade surveys.

Perform tunneling work in accordance with the working hours established for the project. In case of emergency or work stoppages likely to endanger the stability of the excavation or adjacent structures, maintain a full work force 24 hours per day, including weekends and

holidays, until emergency or hazardous conditions no longer jeopardize stability and safety of the work.

7.1.10 Tunnel Line and Grade

The longitudinal centerline of the tunnel shall be sufficiently true and accurate to the tunnel profile grade line to stay within the following tolerances during and upon completion of tunneling: invert of the pipe shall be within 1.5 inches horizontally and 1 inch vertically of the plan line and grade. Survey the pipe invert upon every advancement of the pipe to ensure the elevation and alignment is within the tolerances specified above.

Pipe installation shall be invert elevation controlled and reverse grades are prohibited. Deviations from the design tunnel invert shall not exceed the tolerances specified above at any point during construction and corrections shall not exceed a rate of 3 inches per 100 feet or a lesser rate as determined by the structural characteristics of the pipe.

If the Contractor is unable to maintain these tolerances, he shall bear the full responsibility and expense for correction (redesign, easement acquisition, retunneling, etc.). If design tolerances are exceeded and redesign is required, the Contractor shall obtain the services of a professional engineer registered in the State of Colorado for the redesign. Plans showing the changes shall be submitted to the Engineer for review and approval.

7.1.11 Pipe Jacking

Immediately before joining pipe, the end of the pipe shall be thoroughly cleaned and lubricated with an approved lubricant. The axial forces from the thrust jacks shall be distributed to the pipe uniformly to prevent damage to the ends of the pipe, using pipe cushioning in accordance with approved submittals.

If any part or parts of the pipe becomes unserviceable because the pipe is chipped, gouged, or otherwise damaged before or during installation, it shall be rejected and removed from the site. The City's Construction Project Manager shall make the final determination on rejection and removal of the pipe.

After pipe installation is completed, individual joints shall be pressure tested with a portable hydrostatic tester to 13 psi, in lieu of line infiltration, exfiltration, or air testing.

7.1.12 Contact Grouting

The annulus between the pipe and the ground shall be grouted after pipe jacking is completed. Grouting shall be performed over the entire 360° circumference of the tunnel. The number and location of grout holes in each pipe shall be determined by the Contractor but a minimum of six holes per 20-foot pipe section shall be used. Rings of grout holes shall be spaced at intervals of six feet or less.

Grout shall consist of Portland cement and water or of Portland cement, sand, and water. Grout mixtures may contain bentonite or fly ash. The grout shall consist of 2 parts Portland cement, 1 part fly ash, and not to exceed 6 parts clean, dry, sand.

Contact grout shall be free of lumps when put into the mixer, and the grout mix shall be constantly agitated. Grout shall flow unimpeded and completely fill all voids. Perform the injection of grout continuously on any one pipe section. Fill spaces and voids until completed, so as to avoid disturbance of grout which has taken an initial set.

The grouting process shall be so operated and controlled that the grout will be delivered uniformly and steadily. If, during the grouting of any pipe, grout is found to flow from adjacent grout pipes, such pipes from which grout is flowing shall be closed with valves or plugged with wooden plugs. Where such closing is not essential, ungrouted pipes shall be left open to facilitate the escape of air and water from the space being grouted.

Grouting shall progress from grout pipe to grout pipe in accordance with approved submittals. In going from lower to higher grout pipes, do not make connections to the higher grout pipes until the grout has completely filled the space below the higher grout pipes. As the grouting proceeds, the escape of grout from the upper pipes in turn shall be permitted as an indication of successive satisfactory filling of voids with grout.

Protect and preserve the interior surfaces of the pipe from damage. Minimize grout drop and proceed with cleanup immediately after grouting. Any damage to the pipe caused by or occurring during the grouting operations shall be repaired. The interior lining of the pipe shall be smooth and free from defects.

Maintain and submit records of grouting operations for each shift, including the location and a detailed log of each grout hole, time of each change of grouting operations, pressures, rates of pumping, grout mix, and grout take at each grout hole hook-up.

After grouting, holes shall be filled with dry packed cement mortar grout. Threaded plugs shall be installed flush with the inside face and the remaining void shall be filled with a non-shrink grout rated to 4000 psi.

7.1.13 Installation of Instrumentation

Instrumentation shall be installed at the locations shown on approved shop drawings. Instruments shall be installed in accordance with the approved installation schedule. All instruments shall be clearly marked, labeled, and protected to avoid being obstructed or otherwise damaged by construction operations, the general public, or railroad operations.

Locate conduits and underground utilities in all areas where subsurface geotechnical instrumentation is to be drilled and installed. Subsurface geotechnical instrumentation locations shall be modified, as approved by the City's Construction Engineer, to avoid interference with existing conduits, railroad tracks, utilities, and foundation elements. Repair damage to existing utilities resulting from instrument installations at no additional cost to the City.

Surface monitoring points and arrays shall be installed over the centerline of the tunnel and at offsets as shown in the Contractor's approved submittals to determine the lateral and longitudinal extent of ground movement. The longitudinal spacing of the points shall be a minimum of one every 25 feet along tunneled portions of the project, as allowable based on surface features. The longitudinal spacing of the arrays shall be a minimum of one every 75

feet along tunneled portions of the project, as allowable based on surface features. The arrays shall be centered across the proposed tunnel(s).

Individual surface monitoring points shall be placed along each side of each shaft, a distance of 5 feet and 10 feet from the shaft wall; a minimum of 6 points per shaft shall be installed.

Deep settlement monitoring points shall be installed in accordance with approved shop drawings. The bottom of the instrument shall be located 3 feet above the crown of the tunnel.

Immediately following installation, the location of the top of all instruments shall be surveyed to provide horizontal and vertical coordinates. Data shall be provided to the City's Construction Project Manager in accordance with the submittal requirements specified herein. Re-surveying from control points shall be required a minimum of every two weeks or more frequently as required to address potential disturbances or resolve conflicting data.

7.1.14 Installation of Inclinerometers

Inclinerometers, if required within the contract documents, shall be installed within 5 feet of each shaft as shown on the plans and/or as approved in the submitted shop drawings. Inclinerometer casing shall extend from the ground surface to a depth at least 15 feet below the base of the shaft excavation.

Conduct drilling operations using appropriate methods that are consistent with geologic conditions presented in the Geotechnical Baseline Report. Provide drill casing if required to hold drill hole open. Drill hole or inside of casing, if applicable, shall provide a clear opening (6 inches) in diameter or greater. A log of the soils encountered during drilling shall be accurately maintained, and a copy shall be provided to the City's Construction Project Manager in accordance with the time restrictions stated herein.

Install inclinerometer casing in accordance with the manufacturer's recommendations and approved shop drawings. Grout the annulus between the inclinerometer casing and the ground using a non-shrink cement grout.

Install protective housing with locking cap and padlock. Protective housing shall be installed within an approved flush-mounted traffic rated roadway box or vault so as not to obstruct vehicle or foot traffic.

7.1.15 Instrumentation Monitoring and Reporting

The Contractor shall take initial readings of all instruments to establish a baseline and provide the City's Construction Project Manager with this data, in accordance with the requirements specified herein. The Contractor will read required instrumentation and provide the City's Construction Project Manager with these data. Surface monitoring points and arrays and deep settlement monitoring points within 50 feet of the working face of the tunnel shall be surveyed daily. Inclinerometers shall be monitored daily. The frequency of monitoring may be modified by the Engineer or the City's Construction Project Manager.

The Contractor shall provide data from readings of all instruments to the City's Construction Project Manager within one working day of obtaining the information. The data shall include a copy of the data sheets containing a cumulative history of readings, including

weather conditions, temperature, and proximity of the excavation to the instrument location itself, at the time of each reading.

The Contractor shall abide by the following Response Values:

Instrument	Threshold Value	Shutdown Value
Surface Monitoring Points and Arrays	1.5-inch H or V for Shafts 0.13-inch H or V for Tunnels	3-inch H or V for Shafts 0.25-inch H or V for Tunnels
Inclinometer	1.5-inch H or V for Shafts	3-inch H or V for Shafts
Deep Settlement Monitoring Points	2-inch V	4-inch V

If a threshold response value is reached, the Contractor shall meet with the City’s Construction Project Manager to discuss his/her means and method to determine what changes, if any, shall be made to better control movement. If a shutdown response value is reached, the Contractor shall stop all work immediately. The Contractor shall meet with the City’s Construction Project Manager, the Engineer, and the City’s Project Management Team to develop a plan of action before work can be resumed. All costs associated with shutdown due to reaching maximum limits shall borne by the Contractor.

Remove all instrumentation during the cleanup and restoration work or as required by the City’s Construction Project Manager. All roadway boxes shall be removed. At a minimum, fill the inclinometer casing and deep settlement point casing with a lean cement grout and cut off the upper 3 feet of the instrument and casing which extend below grade.

7.1.16 Cleanup and Restoration

Remove all equipment, unused materials, and debris from the site at the end of the job. Restoration shall follow construction as the work progresses and shall be completed as soon as possible and to the satisfaction of the applicable utility owners and stakeholders. Restore and repair any damage resulting from surface movement caused by the work. Any property or improvements damaged or destroyed, shall be restored to a condition equal to or better than existing prior to construction at no additional cost to the City. Restoration shall be completed immediately if a third party or the City is inconvenienced by the damage, and in no case later than thirty (30) days after the damage is discovered. This provision for restoration shall include all property which was affected by the construction operations.

END OF SPECIFICATION



CITY AND COUNTY OF DENVER
ENGINEERING DIVISION

Wastewater Capital Projects Management Standard Construction Specification

7.2 MICRO TUNNELING

7.2.1 General

Where indicated on the Drawings, or where field conditions dictate that open trenching for the pipeline across railroad tracks, highways, or other obstructions is prohibited, the pipe shall be installed by jacking, tunneling, boring and casing methods, or micro tunneling.

Should the General Contractor, in the process of Project construction, elect to propose that a portion of the pipe be installed by micro tunneling, rather than by jacking, boring or trenching operations, the subject cost shall not total more than the aggregate sum of the removal and replacement costs that such an activity would replace.

7.2.2 Shop Drawings

Detailed shop drawings will be required for all pipe jacking, tunneling and boring installations.

7.2.3 Construction

Work specified in this Section describes the construction of sanitary sewers by jacking fiberglass reinforced polymer mortar (RPM) behind a remotely operated, steerable, micro-tunneling boring machine (MTBM), with RPM serving as both the primary tunnel liner during construction and sanitary sewer pipe (secondary tunnel liner) after completion of construction. The General Contractor shall select and utilize methods and equipment compatible with the selected dimensions of the tunnel and with the anticipated geologic conditions described in the Geotechnical Report (GR).

The micro-tunneling boring machine (MTBM) may be either of the following:

1. Slurry Shield

An MTBM in which the tendency of soil at the excavation face to run or flow uncontrollably into the MTBM is prevented by the counterbalancing force of bentonite slurry contained at the face of the MTBM. During boring, the excavated material is mixed with the bentonite slurry and pumped through a pipe for disposal.

2. Earth Pressure-Balance Shield

An MTBM in which the tendency of the soil at the excavation face to run or flow uncontrollably into the MTBM is prevented by the counterbalancing force of the excavated material which is contained, under pressure, at the face of the MTBM. During boring, the excavated material is mixed with water or bentonite slurry and pumped through a pipe for disposal or by a balanced screw auger or screw conveyor system.

During tunneling and construction operations, the following shall be followed:

- a. Control groundwater in accordance with specified requirements during all micro-tunnel excavation.
- b. Perform micro-tunneling operations in a manner that will minimize loss of ground and minimize settlement of the ground surface, structures, and utilities above and adjacent to the tunnel.
- c. The General Contractor shall perform pre-construction and post-construction surveys of all structures, residences, and other facilities adjacent to the areas of the tunnel.
- d. Maintain clean working conditions at all times inside the tunnel and pits. All muck, slush, grout spills, ponded water, and any other material not required for tunneling shall be removed from the excavations in a timely manner.
- e. All work of excavating, lining, grouting and construction of the jacking operation shall be so executed that ground settlement or loss will be minimized; the completed sewer pipe shall have full bearing against earth, and no voids or pockets will be left in any portion of the Work. The peripheral space between the support elements and the excavated surface (i.e., the diameter of the excavated hole is no larger in diameter than 3/4 inch more than the pipe outside diameter) shall be filled with the bentonite lubricating material. If the diameter of the excavated hole is greater than 3/4 inch more than the outside diameter of the pipe, it shall be promptly filled with suitable material, such as grout, as accepted by the Construction Project Manager. This may require jacking or the pipe be discontinued and additional access pits installed at no extra cost to the City.
- f. The General Contractor shall be aware that various existing soil borings, piezometers or instrument wells coincide with the proposed sewer pipe alignment. These may or may not have been backfilled with grout and therefore caution should be used in tunneling through these existing borings. General Contractor shall take mitigating measures at no additional cost to the CITY to counter any effect these bore holes, piezometers or instrument wells may have on tunneling operations.
- g. All excavations shall remain within the easements and rights of way indicated on the Drawings, to the lines and grades designated on the Drawings, and use methods which include due regard for safety of workmen, adjacent structures, utilities, and the public. Methods of excavation shall be at the General Contractor's option, subject to the review of the Construction Project Manager. Shape the excavation to

fit the sewer pipe section and of sufficient size to allow the construction of the sewer pipe to the lines and grades indicated on the Drawings.

7.2.3.1 Casing Pipe Installation Method

The General Contractor shall have the option to select the method of micro-tunneled casing pipe installation, subject to approval by the Construction Project Manager.

The excavated size of the tunnel shall be determined by the General Contractor based on construction requirements for the secondary lining system, and is subject to the limitations shown on the Drawings.

7.2.4 References

All work shall be performed in accordance with applicable regulations of all federal, state, and local regulations, codes, and standards.

7.2.5 Existing Conditions

7.2.5.1 Restrictions

The General Contractor shall comply with all restrictions set as conditions under which the easement or permission was granted to the Owner to perform the work of this Contract. These restrictions are included with these Specifications. The General Contractor is presumed to have fully determined all special requirements that pertain to each length of sewer in tunnel constructed under this Section.

7.2.5.2 Preliminary Inspections

The General Contractor shall inspect the locations where the access pits and tunnels are to be built to familiarize himself with the conditions under which the Work will be performed and with all necessary detail as to the orderly prosecution of the work in conformance with Instructions for Bidders. The omission of any details necessary for the satisfactory prosecution of the WORK in its entirety, which may not appear herein, shall not relieve the General Contractor of his full responsibility.

7.2.5.3 Soil, Rock and Groundwater

The General Contractor acknowledges that certain soils reports, borings, and other Geotechnical data, more particularly described or referenced in the Standard Construction Specifications of the Contract, have been made available for inspection and review. The borings were made for the use of the City in the design of the Project and are not intended to be interpreted for use in temporary construction facilities designed by the General Contractor.

7.2.5.4 Utilities

The General Contractor shall be responsible for the protection of all utilities encountered during the Work of this Contract. The known utilities are shown on the Contract Drawings and the General Contractor shall take every precaution when working near the utility to locate and protect these utilities. All damage to the existing utilities shall be the sole

responsibility of the General Contractor. The General Contractor shall replace, repair, remedy, or compensate for all damages at no additional cost to the Owner.

7.2.5.5 Structures

The General Contractor shall be responsible for the protection of all structures, roads and railroads above or adjacent to the tunnel, within the framework and criteria set forth in the Contract Documents.

7.2.6 Definitions

1. Micro Tunneling

Shall be defined as a method of installing pipe, by jacking the pipe behind a remotely controlled, steerable, guided articulated Micro-Tunneling Boring Machine (MTBM). The MTBM, which is connected to and followed by the pipe being installed, shall ensure that the soils being excavated are fully controlled at all times.

2. Jacked Pipe

Shall be defined as the General Contractor's sewer pipe that serves as initial construction lining and tunnel support, installed by the General Contractor for stability and safety during construction, and as the sewer line or permanent secondary liner.

3. Jacking System

A system of jacks which pushes the sewer pipe. Capacity of jacks and extension rate is synchronized with excavation rate of the machine.

4. Intermediate Jacking Station

Hydraulic jacks installed at intermediate locations in the pipe string to allow selective shoving of discrete segments of the total pipe.

5. Slurry System

Transportation of excavated material in slurry flow matched to excavation rate. System balances groundwater pressures and separates soil from slurry at end of process. Soil separation methods are not limited to mechanical means. Soil separation method may be chemical in nature.

6. Laser

An optical system projecting a beam to a target to provide guidance for the micro-tunnel excavation.

7. TV

A television system which monitors the progress and alignment of the micro-tunneling machine and pipe.

8. Controls

The system which synchronizes excavation, removal of the excavated material, and jacking of pipe to maintain overall balance to provide complete and adequate ground support at all times.

7.2.7 Quality Assurance

7.2.7.1 General Contractor

The General Contractor must provide proof of successful experience with micro tunnel excavation and support at the depths shown, in the soil and groundwater conditions expected, with the lining systems shown and with the General Contractor's proposed equipment.

7.2.7.2 Project Superintendent

The project superintendent shall have at least five years of tunneling experience and shall have worked on at least two micro-tunneling projects in similar ground conditions using equipment similar to the equipment required for this project. The machine operator shall have at least three years of micro-tunneling experience and shall have worked on at least one tunnel project using the same equipment required for this project.

7.2.8 Quality Control

General Contractor shall establish and maintain quality control for operations under this Section to assure compliance with contract requirements and maintain records of his quality control for materials, equipment, and construction operations including but not limited to the following:

7.2.8.1 Preparatory Inspection

Preparatory inspection shall be conducted prior to commencing work and should include the following as a minimum requirement:

1. Check pipe for conformance to approved certified tests.
2. Check pipe for proper storage and handling.
3. Discuss and review pipe installation procedure with the Construction Project Manager. Discussion shall include placement of pipe, joint preparation and application of each pipe used.

7.2.8.2 Initial Inspection

Initial inspection shall be conducted after a representative sample of the work is complete and should include the following as a minimum requirement.

1. Check for proper depth and grade for pipe.
2. Check method of joining pipes.
3. Check the pipe for proper alignment.

7.2.9 Tolerances

Excavation and jacking of the sewer pipe shall be controlled by the General Contractor to allow construction of the sewer to a true circular shape and to within 1.5 inches on line and 1 inch on grade. Variations from line and grade tolerances listed herein may be allowed provided the line and grade variation is regular and only in one direction, and that the final

grade of flow line is in the direction indicated on the Drawings. When the excavation is off line and grade, the General Contractor shall make corrections to plan line and grade at the rate of 3 inches per 100 feet.

The General Contractor shall survey the tunnel at 50-foot intervals or a minimum of once per tunnel drive to ensure the alignment is within the tolerances specified. The survey shall be conducted immediately behind the tunnel excavation to allow immediate correction of misalignment. Tunnel excavation shall not precede surveyed verification of the alignment by more than 100 feet, or more frequently if line and grade tolerances have been exceeded. The tunnel guidance system may be used; however, the General Contractor shall select times to measure and record this information after the air temperatures have stabilized throughout the pipe to ensure accurate readings.

If the General Contractor is unable to maintain these tolerances, he shall bear full responsibility and expense for correction (redesign, easement acquisition, etc.) If these tolerances are exceeded and redesign of structures is required, the General Contractor shall obtain the services of an independent professional engineer registered in the State of Colorado for the redesign. Plans showing the changes shall be submitted to the Construction Project Manager for review.

7.2.10 General Contractor Submittals

The Construction Project Manager will base the review of submitted details and data with consideration of requirements for the completed work, utilities, and the possibility of unnecessary details in the execution of the work to be constructed under this Contract. Review of the General Contractor submittals by the Construction Project Manager shall not be construed in any way as relieving the General Contractor of his responsibilities under this Contract.

The General Contractor shall submit the following to the Construction Project Manager for approval and/or examination:

1. Working Drawings

Complete working drawings showing details of the proposed method of construction and the sequence of operations to be performed during construction shall be submitted. Working drawings shall show the method of micro-tunneling, including the micro-tunneling system to be used, location of access pits including method of excavation, shoring and bracing appurtenance installation, and dewatering techniques that are proposed to be used. The following shall be included as the minimum level of detail required:

- a. A detailed description of the micro tunneling procedure including construction techniques to provide the access required to install pipe in conformance with the Contract Documents.
- b. Manufacturer's literature describing in detail the micro-tunneling system to be used. Detailed description of projects on which this system has been successfully used including the names, addresses and telephone numbers of owner's representatives for these projects as well as length, diameter, and pipe material used.

- c. Calculations and drawings indicating limits of access pits and any ground support to be utilized.
- d. Method of spoils disposal.
- e. A groundwater stabilization scheme covering the excavations for starter and receiver pits. Verify this plan to stabilize anticipated unstable soil conditions. Such verification shall include all calculations and detail drawings for methods of controlling groundwater.
- f. Certification by the machine manufacturer of the thrust, torque, condition, and operational characteristics of all equipment to be used for installing the specified pipes. The micro-tunneling equipment shall employ a spoil removal system with a pressure balance system that is capable of equalizing pressures between the tunnel face and the micro-tunneling machine head in order to prevent caving beyond the outside diameters of the pipe.
- g. Layout of tunneling and ancillary equipment at each jacking and receiving (access) pit location.
- h. Tunnel machine shop drawings including configuration of cutter head and over cut.
- i. Ventilation system details.
- j. Pipe lubrication system details.
- k. Electrical system and lighting details.
- l. Grade and alignment control system details.
- m. Tunneling machine groundwater control provisions.
- n. Gas monitoring system.
- o. Details of mucking system and soil separation methods including proposed slurry formulations and calculations of the system capacity to handle flows at all distances and changes of elevation to and from the tunnel machine.
- p. Details of jacking system, intermediate jacking stations and their proposed spacing, method of operation, and thrust capacity. Include calculations of anticipated jacking forces required to advance the pipe. Include sleeve details and supporting gasket compression calculations for joints and gaskets used with intermediate jacking stations. Describe controls to prevent the maximum jacking force from being exceeded.
- q. Details of grouting the annulus space after pipe has been installed including injection pressure and method of controlling grout pressures.
- r. Grouting techniques to be used for over excavation if any, including equipment, pumping procedures, pressure grout types and mixtures.
- s. Procedures for measuring excavation quantities versus forward progress during the tunneling operation.

- t. Calculations demonstrating that the pipe selected has been designed to support the maximum anticipated earth loads and superimposed live loads, both static and dynamic, which may be imposed on the pipe. Determine the additional stresses imposed on the pipe during jacking operations and upgrade the quality and strength of the pipe and pipe joints to the extent necessary to withstand the additional stresses imposed by the jacking operation. The details shall be submitted for approval.
- u. Complete information on General Contractor's safety plan for personnel conducting the micro-tunneling operations and appurtenance installation. The plan shall include provisions for lighting, ventilation, and electrical safeguards.
- v. Keep and maintain at the construction site a complete set of field drawings for recording as-built conditions. It shall have marked or noted thereon all field information, properly dated, recording as-built conditions. This set of field drawings shall be kept up to date.
- w. Pipe certification of compliance.
- x. Pipe jointing methods and details.
- y. All General Contractor submittals requiring structural design shall be signed by a professional civil or structural engineer registered in the State of Colorado.
- z. Written documentation summarizing the qualifications of the project superintendent, machine operators, and site safety representative.

2. Log of the Jacking Operations

The General Contractor shall submit a log of jacking operations; the log shall be taken at intervals of no more than 10 minutes apart and a minimum of four readings per pushed 10 foot and accomplished by digital video recording of the TV image at the operator's console. Video shall show a real-time clock that matches the time scale used in the log. Indicators in the tunneling machine being viewed by the digital recorder shall indicate when the tunneling machine is excavating and the number of the pipe joint that is being pushed. The log shall be submitted to the Construction Project Manager each day. The digital video shall be submitted to the Construction Project Manager each week. As a minimum, the log shall consist of the following:

- a. The position of the tunneling machine in relation to the design line and grade.
- b. The jacking forces exerted on the pipe at each jacking station.
- c. The date, the starting time, and the finish time.
- d. The position of the steering jacks.
- e. Inclination.
- f. Cutter head torque.
- g. Slurry flow rates in both the supply and return lines (if slurry is used).
- h. Face pressure.

- i. Hydraulic pressure (on hydraulic motor machines).
- j. LEL gas readings.

3. Pipe Lubricant

Submit a separate log tracking pipe lubricant used in gallons, its viscosity, and pumping pressure. Log shall be submitted to the Construction Project Manager each day

4. Muck Removal

Submit a separate log tracking the volume of muck removed from the site. Log shall be submitted to the Construction Project Manager each day.

5. Survey Records

Submit survey records of the horizontal and vertical positions of surface control points and other instrumentation within 24 hours of measurements as required herein.”

6. Inclinator Data

Inclinometer data shall be plotted on a cumulative time-deflection plot, using commercial software from the manufacturer, with past readings shown together with most current so that trends can easily and quickly be established by the Construction Project Manager and General Contractor.

7.2.11 Products

7.2.11.1 Equipment

No gasoline powered equipment shall be permitted in the tunnel operation. Diesel, electrical or air-powered equipment will be acceptable, subject to applicable federal and state regulations. Diesel engines equipped with scrubbers are acceptable only when jacking in free air. Provide compressed air and electricity for General Contractor’s operations from a source outside the pipe.

1. Micro Tunnel Boring Machine (MTBM)

The General Contractor shall employ MTBM that is capable of handling the various anticipated ground conditions. In addition, the MTBM shall:

- a. Have a “closed” face which is capable of minimizing loss of ground ahead of and around the machine and providing satisfactory support of the excavated face at all times and shall have the capability of setting a calculated earth balancing pressure and positively measuring the earth pressure at the face.
- b. Provide a system to indicate whether the amount of earth material removed is equivalent to that displaced by the advance of the machine such that the advance rate may be controlled accordingly.
- c. Conform to the shape of the tunnel with a uniform perimeter that is free of projections that could produce over excavation or voids.
- d. Be articulated to enable remote steering of the system.
- e. Have a display available to the operator, at an operation console, showing the position of the shield in relation to a design reference together with other information such as face pressure, roll, pitch, steering attitude and valve positions.

- f. Incorporate a seal in the tail of each MTBM shield to prevent leakage of lubricating liquid or grout, into the tunnel space, between the MTBM shield and lining.
- g. Have a cutter head powered by electric or hydraulic motors and have motors and operating controls protected against water inflows.
- h. Provide a bi-directional drive on the cutter head wheel.
- i. Provide means for maintaining the tunnel face under wet and adverse soil conditions. Use closure doors on the cutter wheel or other means acceptable to the Construction Project Manager.

2. Automated Spoil Transportation

The General Contractor shall provide a MTBM which includes an automated spoil transportation system which shall:

- a. Match the excavation rate to the rate of spoil removal thereby maintaining settlement or heave within tolerances specified.
- b. Balance ground water pressures by the use of a slurry pressure balance system which shall be capable of any adjustment required to maintain face stability for the particular soil condition encountered on the Project and shall monitor and continuously balance the ground water pressure to prevent loss of slurry and or ground water.
 - In a slurry spoil transportation system the ground water pressure shall be managed by use of the slurry pumps, pressure control valves, and a flow meter.
 - A slurry bypass unit shall be included in the system to allow the direction of flow to be changed and isolated, as necessary.
 - A separation process shall be provided when using the slurry transportation system which shall be designed to provide adequate separation of the spoil from the slurry so that the clean slurry can be returned to the cutting face for reuse. Spoil shall be appropriately contained at the site prior to disposal.
 - The type of separation process used shall be dependent upon the size of the tunnel being constructed, the soil type being excavated, and the work space available at each work area for erecting the plant.
 - The composition of the slurry shall be carefully monitored for specific gravity and viscosity.
- c. Balance ground water pressures by the use of an auger earth pressure balance system which shall be capable of any adjustment required to maintain face stability for the particular soil condition to be encountered on the Project and shall monitor and continuously balance the ground water pressure to prevent loss of ground water.
 - If an auger spoil transportation system is utilized, the ground water pressures shall be managed by controlling the volume of spoil removal with respect to the advance rate (Earth Pressure Balance Method) and the application of

compressed air. The speed of rotation of the auger flight, the addition of water, and/or compressed air shall be monitored.

- The Construction Project Manager's approval will be required where an auger soil transportation system is proposed for use by the General Contractor in the presence of ground water. Such approval will be based on an evaluation of the equipment's ability to balance soil and water pressures at the face, stability of the soils, and the significance of the ground water present.

3. Pipe Jacking Equipment

The General Contractor shall provide a MTBM which includes a pipe jacking system which shall:

- a. Have the main jacks mounted in a jacking frame located in the starting pit.
- b. Have a jacking frame which shall successively push the MTBM along with a string of connected pipes toward a receiving pit.
- c. Have sufficient jacking capacity to push the MTBM and the string of pipe through the ground.
 - Calculations shall be made to determine the face excavation forces, frictional factor, and weight of the MTBM and pipes.
 - The jacking equipment installed must have a capacity at least 20 percent greater than the calculated theoretical jacking load.
- d. Have hydraulic cylinder extension rates which are synchronized with the excavation rate of the MTBM, which shall be determined by the soil conditions.
- e. Have intermediate jacking stations which shall be provided when the calculation of the total jacking force needed to complete the installation exceeds 80 percent of the capacity of the main jacks or the designed working compressive loads (including safety factor) allowed for the pipe.
- f. Develop a uniform distribution of jacking forces on the end of the pipe by use of spreader rings and packing.
- g. Provide for a pipe lubrication system which shall be used if the calculated jacking forces are expected to exceed the pipe design strength (including the 2.5 to 1 safety factor) or if the actual jacking forces encountered exceed 80 percent of the pipe design strength (including the 2.5 to 1 safety factor). Should either of these conditions occur, an approved lubricant shall be injected to lower the friction developed on the surface of the pipe during jacking.

4. Remote Control System

The General Contractor shall provide a MTBM which includes a remote control system which shall:

- a. Allow for the operation of the system without the need for personnel to enter the micro-tunnel. In man entry sized pipes, intermittent entry of personnel will be

permitted for maintenance and removal of equipment once the pipe installation is complete, provided that all safety precautions specified elsewhere and required by law are in place and functional.

- b. Integrate the system of excavation and removal of soil and its simultaneous replacement by pipe. As each pipe section is jacked forward, the control system shall synchronize all of the operational functions of the system.
- c. Provide complete and adequate ground support at all times.

5. Active Direction Control

The General Contractor shall provide a MTBM which includes an active direction control system which shall:

- a. Control line and grade by a guidance system that relates the actual position of the MTBM to a design reference (e.g., by a laser beam transmitted from the jacking pit along the center line of the pipe to a target mounted in the shield).
- b. Be capable of maintaining grade to within plus or minus one inch and line to within plus or minus 1.5 inches.
- c. Provide active steering information which shall be monitored and transmitted to the operation console.
- d. Provide minimum steering information available to the operator on the control console which includes the position relative to the reference, role, inclination, attitude, rate of advance, installed length, thrust force, and cutter head torque.

6. Ventilation and Monitoring

Equipment shall be provided to adequately ventilate the entire micro-tunneling operation at all times during construction.

- a. Portable testing equipment shall be provided for carbon monoxide gas, hydrogen sulfide gas, oxygen deficiency and explosive gases.
- b. An automatic gas alarm to detect explosive gases shall be provided on the Micro-Tunnel Boring Machine. The audible alarm shall be located in the jacking pit and shall be active at all times.

7. Electrical Systems

All electrical systems utilized on the Micro-Tunnel Boring Machine shall be equipped with appropriate ground fault systems. All electrical systems are to be insulated, not permitting any bare wire exposures. Motors and controls shall be equipped with an automatic shutoff such as MSA Methane Monitoring System VI or equal.

8. Additional Safety Equipment

Necessary equipment for tunnel excavation shall include signal systems, fire extinguishers, safety equipment, and other equipment required by the General Contractor's method of construction. Such equipment shall be maintained in good repair.

7.2.11.2 Jacked Pipe

Pipe for jacking shall be designed to carry all jacking loads. Refer to individual pipe specification sections.

7.2.11.3 Pipe Joints

The outside walls shall be straight without bell modifications. All joints shall be watertight.

7.2.12 Design

The General Contractor shall be responsible for the design of the fiberglass reinforced polymer mortar pipe to carry the loads imposed on it during construction, including the jacking forces.

7.2.13 Excavation

7.2.13.1 General Tunnel Requirements

Tunnel excavation shall not begin until:

- a. The work Plan and all required submittals have been submitted by the General Contractor and reviewed and returned approved by the Construction Project Manager.
- b. The required Pre-Construction Surveys have been completed.
- c. All instrumentation along the tunnel alignment is in place, stable, and baselines have been established.
- d. All pre-job safety meetings required by OSHA and/or General Contractor's Safety Plan have been held.

7.2.14 Micro-Tunneling

The General Contractor shall conduct all micro-tunneling operations in accordance with all applicable safety rules and regulations. The following shall apply to micro tunneling operations:

1. No work shall commence until the design and construction procedure has been approved in writing by the Construction Project Manager. The General Contractor is totally responsible for the performance of the equipment and methods selected for this phase. The Construction Project Manager's approval signifies only that the construction process is compatible with the overall objectives of the project.
2. The pipe used for jacking shall be round, have a smooth, even outer surface, and have joints that allow for easy connections between pipes. Pipe ends shall be square and smooth so that jacking loads are evenly distributed around the entire pipe joint and such that point loads will not occur when the pipe is jacked in a reasonably straight alignment. Pipe used for jacking shall be capable of withstanding all forces that will be imposed by the process of installation, as well as the final in place loading conditions. The driving ends of the pipe and intermediate joints shall be protected against damage.
3. The pipe, insofar as practical, shall be micro-tunneled from the downstream end.
4. A jacking frame shall be provided for developing a uniform distribution of jacking forces around the periphery of the pipe. Special care shall be taken by the General Contractor to ensure that the thrust reaction backstop is properly designed and constructed. The

backstop shall be square with the proposed pipe alignment and shall be designed to support the maximum obtainable jacking pressure with a factor of safety of at least 2.0. The jacking system shall be capable of continuously monitoring the jacking pressure and rate of advancement. Special care should be taken when setting the pipe guard rails in the pit to ensure correctness of the alignment.

5. The General Contractor shall maintain an envelope of bentonite slurry, or other similar material, around the exterior of the pipe during the jacking and excavation operation to reduce the exterior friction and the possibility of the pipe freezing in place. Water jetting of the pipe bedding or backfill shall not be permitted.
6. The pipe freezes and the General Contractor is unable to move it again, the General Contractor may be permitted to construct an intermediate access pit, with the location subject to review by the Construction Project Manager . The General Contractor shall be solely responsible for making arrangements for such an intermediate pit and shall be solely responsible for any and all costs associated with the location and construction of the pit and for maintaining traffic in the area.
7. In the event a section of pipe is damaged during the jacking and excavation operation, one of the following procedures shall be used to correct the damage, as directed by the Construction Project Manager.
 - a. Slightly damaged pipe which passes leakage test and maintains pipe barrel and joint structural integrity shall be repaired in place with a method approved by the manufacturers.
 - b. Severely damaged pipe shall be removed from the excavation by jacking it through the excavation and removing it at an access pit.
8. The joints shall be made watertight by using rubber gaskets.
9. The pipe joints shall be cushioned by a plywood ring between the joints, or by other methods, to transmit the jacking forces without damage to the pipe or pipe joints.
10. After the pipe is in place and the jacking and excavation operation is complete from one access pit to the next; any over excavation greater than the pipe outside diameter plus 3/4 inch shall require the pipe to be grouted in place.

7.2.15 Grouting

The General Contractor shall furnish and operate suitable equipment for all grouting operations.

After completion of the jacking operation, the lubricate material shall be displaced from between the pipe exterior and surrounding ground by a cement grout. Pressure and the amount of grout shall be controlled by the General Contractor to avoid pipe damage and displacement of the pipe and soil beyond specified tolerances. Grouting shall be accomplished as soon as possible after pipe installation has been completed to prevent any surface settlement due to movement of soil material into the void space or loosened zone around the pipe.

All voids outside the limits of the excavation created by caving or collapse of earth cover over the excavation, or by other cause shall also be completely filled with pea sized gravel or sand cement grout. Pressure-injected grout shall be placed at the same frequency as required when placing grout behind the pipe.

Pressure-injected grout used in conjunction with pea gravel shall be placed behind the pipe if required to minimize ground loss. General Contractor shall provide seals on the tail of the tunnel boring machine which will prevent the pea gravel or grout from moving into the shield.

7.2.16 Jacking Pits

Construction techniques required to provide access for micro-tunneling shall be such as to ensure the safety of the work. Acceptable excavation methods include the use of interlocked steel sheetpiling or open excavation. Final dimensions of access pits selected by the General Contractor shall conform as a minimum with dimensions required to permit installation of the work.

The General Contractor shall be required to properly support all excavations and to prevent all movement of the soil, pavement, utilities or structures outside of the excavation. All pits shall conform to applicable Local Safety Standards, OSHA Standards, trenching, and shoring standards.

If at any time the method being used by the General Contractor for supporting any material or structure adjacent to any excavation is not safe in the opinion of the Construction Project Manager or applicable federal, state or local inspection authorities, the Construction Project Manager may require and the General Contractor shall provide additional bracing and support necessary to furnish the added degree of safety required by the Construction Project Manager. The General Contractor shall provide such added bracing and support by such method approved by the Construction Project Manager as he may elect to use but the taking of such added precautions shall in no way relieve the General Contractor of his sole final responsibility for the safety of lives, work, and structures. The use of such additional bracing and support shall be without additional cost to the City. The absence of an order from the Construction Project Manager for the aforementioned additional bracing shall in no way relieve the General Contractor of his sole final responsibility.

Pits shall be constructed to accommodate the installation of pipe casings, slurry shield, and jacking device. Install thrust block as required and consolidate the ground where the casings enter and exit the ground.

All work of excavating shoring and bracing shall be so executed that settlement is minimized, the in-place casing shall have full bearing against earth, and no voids or pockets are left in any portion of the work.

Before beginning construction, the General Contractor shall adequately protect existing structures and other permanent objects. The repair of or compensation for damage to

permanent facilities due to negligence or lack of adequate protection on the part of the General Contractor will be at no cost to the City.

The General Contractor shall provide surface drainage during the period of construction to protect the work. Provide all dewatering and test any groundwater discharges. All discharge limits and reporting requirements shall be the responsibility of the General Contractor.

Size and locate pits and their work areas so as to avoid interference with traffic.

Blasting will not be permitted.

7.2.17 Line and Grade

The Construction Project Manager has established the baselines and benchmarks as indicated on the Contract Drawings. The General Contractor shall check these baselines and benchmarks at the beginning of the contract period and report any errors or discrepancies to the Construction Project Manager.

The General Contractor shall use the baselines and benchmarks to furnish and maintain all reference lines and grades for the micro-tunnel construction. These lines and grades shall be used to establish the exact location of all micro-tunneling, excavations and structures.

The General Contractor shall establish and be fully responsible for the accuracy of his own control for the construction of the entire project, including access shaft locations, structures, excavation, pipe alignment and grade. The General Contractor shall submit copies of field notes used to establish all lines and grades.

The General Contractor's control points shall be established sufficiently far from the tunnel operation not to be affected by ground movement.

The General Contractor shall maintain daily surveying records of alignment and grade and shall submit three copies of these records to the Construction Project Manager . The General Contractor, however, remains fully responsible for the accuracy of his work and the correction of it, as required.

The General Contractor shall check his control for his excavation against an above ground undisturbed reference at least once each week and once for each 250 feet of tunnel constructed, or more often as needed or directed by the Construction Project Manager .

After installation of the sewer pipe, the General Contractor shall provide the Construction Project Manager with access to the tunnel for visual inspection of the line and grade of the completed in place sewer pipe.

Guidance laser system shall be mounted in a manner that isolates it from effects of movement by the jacking forces.

7.2.17 Earth Movement

The General Contractor shall be responsible for all damages due to settlement from any construction induced activities or occurrences.

The General Contractor is advised of the proximity of buildings, structures, roads, and utilities to the work. Precautions shall be taken to avoid damage or settlement to any of these. Such precautions shall include the use of construction methods and equipment to minimize loss of earth at the excavation face and settlement of earth around the sewer pipe.

In the event any movement of earth is detected, the Construction Project Manager may order the work stopped and secured. Before proceeding, the General Contractor shall correct any problems causing or resulting from such movement.

The General Contractor should be aware that if settlement of the ground surface should occur during construction, which will affect the accuracy of the temporary benchmarks established by the Construction Project Manager, it shall be the General Contractor's responsibility to detect and report such movement. The locations of the permanent City monumentation benchmarks (BM) and temporary benchmarks (TBM) are indicated on the Drawings; the General Contractor may use these to verify temporary benchmark accuracy. Advise the Construction Project Manager and the City of any settlement affecting the permanent monumentation benchmarks. Upon completion, the field books pertaining to monitoring of the permanent monumentation benchmarks shall be submitted to the City.

7.2.18 Excavated Material

Remove and dispose of all excavated materials from jacking pit and tunnel excavations in accordance with the requirements of State of Colorado.

7.2.19 Infiltration Leakage Test

The tests shall be performed by the General Contractor under the observation of the Construction Project Manager. A test section is defined as the length of tunnel between manholes or structures.

Leak testing shall be by television inspection after dewatering operations have been discontinued a minimum of 48 hours and until groundwater has been allowed sufficient time to reach its natural elevation. Any leakage found during this operation shall be corrected.

Each joint shall also be tested in place by exerting a pressure of 11.2 psi absolute on it in accordance with ASTM D 3754. The internal test pressure, which is 3.5 psi lower than normal atmospheric pressure, shall be in addition to the normal external hydrostatic pressure exerted on the pipe by the groundwater above the pipe. Each joint when tested in this manner shall exhibit no infiltration of groundwater into the pipe. The General Contractor may at his option, test sections of the sewer using this method instead of individual joints. If this method is selected each section shall exhibit no infiltration of ground

water into the section. The General Contractor shall isolate any joints which are found to leak during this test and jack such joints through until all joints between manholes are found to be watertight under these conditions.

One hundred percent of the sewer and sewer joints shall be tested.

The General Contractor shall repair all visible leaks in manholes, structures, and joints even if the leakage test requirements are met.

Adequate bulkheads, or plugs, shall be installed at each end of the sewer pipe in preparation for testing. The General Contractor shall submit the type of bulkhead, or plug, to be used to the Construction Project Manager for review. After testing, the bulkheads or plugs shall remain in place until the sewer is put into service, at which time the General Contractor shall remove the bulkheads or plugs.

7.2.20 Restoration

The General Contractor shall promptly restore to their original condition any streets, curbs, sidewalks, or any other facilities which are damaged, moved or disturbed as a result of tunneling operations or jacking pit construction. Any surface or subsurface settlement shall be restored to pre-construction conditions.

End of Specification



CITY AND COUNTY OF DENVER
ENGINEERING DIVISION

Wastewater Capital Projects Management Standard Construction Specification

7.3 SHAFT EXCAVATION AND SUPPORT

7.3.1 Definitions

7.3.1.1 Geotechnical Data Report (GDR)

A document that presents an interpretation of the known subsurface data for the project.

The purpose of the GDR is to compile all geological, geotechnical, groundwater, and other data obtained from the geotechnical investigations for use by the various participants in the project. If available, this information will be included within the contract documents as specifically applicable to the project.

7.3.1.2 Geotechnical Baseline Report (GBR)

The intent of a GBR is to clearly and contractually define the geotechnical conditions through which tunneling will occur in order to evaluate a differing site condition (if encountered) and it is used as a basis of bid for the contractor. By assessing the anticipated geotechnical conditions for a project and providing baselines in the contract, the contractor has a basis from which to prepare their bid and select their means and methods. The baseline conditions do not necessarily reflect the actual conditions; they are not geotechnical fact to be encountered. Rather, they represent the owner's assumption of existing geotechnical conditions for the project. If available, this information will be included within the contract documents as specifically applicable to the project. Regardless of inclusion, this information shall be investigated, interpreted, verified and/or developed by the contractor prior to commencement of the work.

7.3.2 Section Includes

The work specified in this section includes requirements for design, excavation, and support of the entry shaft(s), jacking pit(s), exit shaft(s), and receiving pit(s) for all tunneling operations required within the Contract Documents. The Contractor shall design, furnish, install, and maintain a system of supports, including all bracing and associated items, to retain excavations in a safe manner and to control ground movements as specified herein. Acceptable means of shaft support include: pre-fabricated systems such as slide-rail; rib and lagging; sheet pile; or liner plate. The means and methods utilized to accomplish the project scope are the Contractor's responsibility. All costs incurred for completion of this item shall be included within the applicable bid items(s) for construction of the associated facility.

7.3.3 Requirements

The Contractor shall have the sole responsibility for maintenance and protection of existing utilities, structures, railroad tracks, and facilities within the zone impacted by shaft construction.

The Contractor shall have the sole responsibility for sizing the shafts within the site boundaries shown on the Construction Drawings. The size of the excavations shall be adequate to construct all structures required and to gain access to tunneling and contact grouting operations.

Shaft support systems shall be in accordance with OSHA Health and Safety Standards for Excavations, 29 CFR Part 1926. Shaft support systems shall also meet the standards and guidelines of all **applicable utility companies, and stakeholders**.

The Contractor shall allow the Engineer, City's Construction Project Manager and City's Project Management Team access to the shafts, and to use the shafts to access tunnel operations.

7.3.4 Submittals

7.3.4.1 Preconstruction

Submit the following shop drawings and plans a minimum of 8 weeks prior to beginning shaft construction to allow for review by the City's Construction Project Manager, utility owners, and stakeholders:

1. Detailed description of the procedures, equipment, and methods proposed to conduct the shaft excavations.
2. Shop drawings of shafts including locations, dimensions, and support elements.
3. Shop drawings and descriptions of the procedures and methods proposed for the construction shoring system(s), including a minimum: erection scheme; support element descriptions, sizes, spacings, and strengths; design calculations; plan for removal of shoring. Shafts shall be designed and constructed to withstand all imposed loads, including soil conditions, **Cooper E80 loads**, dynamic loads from
4. Equipment and surcharge loads from materials. Calculations shall include loads, methods, assumptions, results, and safety factors. Shop drawings and calculations shall be signed and stamped by a professional engineer registered in the State of Colorado.

7.3.5 Materials

7.3.5.1 Structural Steel

Structural steel members, such as fabricated connections and accessories, steel W shapes, and other structural steel shall conform to the requirements of ASTM A 572 or ASTM A 36, unless otherwise approved.

7.3.5.2 Slide-Rail

Pre-engineered system of panels, corner slide-rails, linear slide-rails, and cross braces as manufactured by Speed Shore Corporation or equivalent.

7.3.5.3 Lagging

Timber lagging shall be of construction grade and shall be any species that provides a minimum allowable bending stress of 1,100 psi.

7.3.5.4 Lagging Backfill

Backfill sand shall conform to ASTM C 778 for 20-40 sand. Plugging material such as Excelsior or dry pack shall be used to prevent backfill sand from running.

7.3.5.5 Sheet Piles

Steel sheet piling shall be continuous interlocking made in accordance with ASTM A 328 or ASTM A 857 or from steel meeting the requirements of ASTM A 570 or ASTM A 36.

7.3.5.6 Liner Plate

Steel for liner plate shall be ASTM A 569 with a minimum yield of 28 ksi and a minimum ultimate strength of 42 ksi.

7.3.6 General Shaft Requirements

Commence shaft excavations only after submittals have been reviewed and approved by the Engineer, applicable utility companies, and stakeholders, and a pre-construction meeting has been conducted.

Provide all excavations with a gravel pad or concrete working slab equipped with a sump to pump out water.

No gasoline-powered equipment shall be permitted. Diesel, electrical, hydraulic, and air powered equipment is acceptable, subject to applicable City, State, and Federal regulations.

7.3.7 Utilities

All utilities shall be preserved without interruption.

Location of utilities shown on the Construction Drawings shall be considered approximate. Field locate each utility potentially impacted by the work to verify location prior to beginning underground construction at each location.

Coordinate with each utility agency as necessary prior to relocation, hanging, or upgrade of utilities in the vicinity of shafts, pits, and excavations.

7.3.8 Slide-Rail

The slide-rail system shall be installed simultaneous with soil excavation in accordance with manufacturer recommendations.

7.3.9 Soldier Pile and Lagging

Install piles in predrilled holes to the tip elevations shown on approved submittals. Provide casing or drilling mud as needed to prevent caving of holes and loss of ground in predrilled holes.

After soldier pile has been seated plumb in the drill hole, encase it with concrete from the tip to the bottom level of the final excavation. Concrete strength shall be in accordance with approved submittals, and shall be placed by means of a tremie system. Apply vibration through the pile.

Provide timber lagging of sufficient strength to withstand lateral earth pressures. Install lagging with no gap between adjacent boards. As installation progresses perform the following as selected by the excavation and support designer: 1) backfill the voids between the excavation face and the lagging with sand or pea gravel packed into place, 2) pack voids with materials such as straw, burlap, or geotextile fabric, or 3) grout voids with cementitious materials. Where necessary, allow drainage of groundwater without loss of ground due to piping.

7.3.10 Steel Sheet Piling

Drive in plumb position with each sheet pile interlocked with adjoining piles for its entire length so as to form a continuous diaphragm throughout the length of each run of wall, bearing tightly against original ground.

Drive to the depth indicated on approved shop drawings; exercise care in driving to avoid damaging adjacent utilities and structures, and so that interlocking members can be extracted without damaging adjacent structures or utilities.

7.3.11 Liner Plate

Install liner plate around the full perimeter of the shaft excavation. The unsupported height of soil at the base of the shaft shall be no greater than the height of one course of liner plate. Upon completion of liner plate installation, backfill the annulus between support elements and the ground with excelsior and/or grout as needed to prevent inflow of soil or groundwater.

7.3.12 Internal Bracing System

The internal bracing support system shall include wales, struts, and/or shores as applicable.

Provide web stiffeners, plates, angles, and struts with intermediate bracing as needed to prevent rotation, crippling, or buckling of connections and points of bearing between structural steel members. Allow for eccentricities caused by field fabrication and assembly.

Install and maintain all bracing support members in tight contact with each other and with the surface being supported.

7.3.13 Disposal of Excess Excavated Material

Excess excavated material shall be disposed of in accordance with the Contract Documents.

7.3.14 Removal of Support System

Temporary shoring systems shall be removed completely at the end of the job. If the Contractor intends to leave any portion of the support system in the ground permanently, he must first get the approval of the property owner where the support elements are located. In the event that the support system is not fully removed, all shoring elements within 5 feet (minimum) of the ground surface, including soldier piles, wales, struts, lagging, sheet piles, and shores shall be removed. Removal of the support system shall be performed in a manner

that will not disturb or harm adjacent construction or facilities and only after backfill has been fully compacted. All voids created by the removal of the construction shoring system(s) shall be immediately filled with controlled density fill, lean concrete, or cement grout, as approved by the City's Construction Project Manager.

END OF SPECIFICATION



CITY AND COUNTY OF DENVER
ENGINEERING DIVISION

Wastewater Capital Projects Management Standard Construction Specification

7.4 PERMEATION GROUTING

7.4.1 Definitions

7.4.1.1 Geotechnical Data Report (GDR)

A document that presents an interpretation of the known subsurface data for the project. The purpose of the GDR is to compile all geological, geotechnical, groundwater, and other data obtained from the geotechnical investigations for use by the various participants in the project. If available, this information will be included within the contract documents as specifically applicable to the project.

7.4.1.2 Geotechnical Baseline Report (GBR)

The intent of a GBR is to clearly and contractually define the geotechnical conditions through which tunneling will occur in order to evaluate a differing site condition (if encountered) and it is used as a basis of bid for the contractor. By assessing the anticipated geotechnical conditions for a project and providing baselines in the contract, the contractor has a basis from which to prepare their bid and select their means and methods. The baseline conditions do not necessarily reflect the actual conditions; they are not geotechnical fact to be encountered. Rather, they represent the owner's assumption of existing geotechnical conditions for the project. If available, this information will be included within the contract documents as specifically applicable to the project. Regardless of inclusion, this information shall be investigated, interpreted, verified and/or developed by the contractor prior to commencement of the work.

7.4.1.3 Permeation Grouting

The direct pressure injection of a chemical fluid grout into the ground to fill the spaces between soil particles, without causing excessive movement or fracturing of the soil formation. Permeation grouting is performed prior to commencement of tunneling operations to provide a more consistent and stable soil matrix.

7.4.1.4 Chemical Grout

A chemical fluid grout that sets and alters the physical properties of a geologic mass, typically composed of (1) matrix forming base materials, (2) reactants and, (3) accelerators or retarders.

7.4.2 Section Includes

This item includes pre-excavation ground stabilization as required within the Contract Documents by permeation grouting. Permeation grouting shall be performed in accordance with these specifications. If applicable, the general extents of permeation grouting for a specific project may be shown in the plans.

7.4.3 Requirements

The purpose of the grouting program is to stabilize non-cementitious granular soil and fill as shown on Construction Drawings. The permeation grouting program is to be completed prior to beginning tunnel construction.

The effectiveness of the grouting program shall be verified in accordance with requirements specified herein.

Restricted work hours and permits are as specified in the Contract Documents. The Contractor shall coordinate all work with affected utility companies, and stakeholders and comply with the requirements outlined within any access and/or construction permit obtained by the City.

7.4.4 Quality Control

Before the Contractor begins tunnel construction, demonstrate to the City's Construction Project Manager, using either drilling and sampling methods, geophysical methods, data records during grouting operations, or other acceptable means as stated in the approved quality control program, that the grouting zones have been thoroughly impregnated and stabilized with chemical grout. If grouting zones are found to be inadequately treated, the Contractor shall perform additional chemical grouting as needed and at no additional expense to the City.

The Contractor shall obtain samples of grout used for chemical grouting for gel time checks: at least one for every half-hour of pumping or for every 250 gallons of grout, whichever is more frequent. The gel samples shall be labeled and stored in accordance with manufacturer recommendations until completion of the project.

7.4.5 Submittals

7.4.5.1 Preconstruction

Submit the following shop drawings and plans a minimum of 8 weeks prior to mobilization of grouting equipment for review by the City's Construction Project Manager, utility owners and stakeholders:

1. Certificates of compliance for materials specified herein. Certificate of origin for reactant materials.
2. Proposed grout mix, gel time, and certified laboratory testing results documenting the required strength of soil samples injected with the proposed chemical grout mix, at least 45 days prior to beginning grouting operations.
3. Detailed chemical grouting work plans and shop drawings, describing the grouting approach, the chemical grout to be used, grout hole locations and orientations, grout pipe installation procedures, locations and arrangement of injection points, grouting

equipment, injection procedures and sequences, proposed injection pressures, recording equipment, data reporting methods, work sequences, schedules, method of monitoring and protecting existing utilities; testing methods to be used to verify the effectiveness of grouting with respect to strength and acceptance criteria; quality assurance program and methods for determining that grouted zones are effectively stabilized; and any other information necessary to demonstrate compliance with the specified purpose of this grouting work. Also show grout target volumes at each proposed grout injection point including assumptions with respect to porosity and target volumes. Indicate cure time required for chemically grouted soil to obtain required strength prior to tunneling.

7.4.5.2 During Construction

Submit records of grouting operations to the City's Construction Project Manager on a daily basis. Include grout mix, gel time, injection date and time, injection pressure and rate, injection volumes and exact injection locations. Provide data in an acceptable chart-type format that facilitates rapid visual evaluation of the results of the work, and update daily.

Submit results of surface monitoring point and settlement monitoring point array monitoring on a daily basis.

Submit test results by the end of the day in which they were taken, and with frequency as specified herein.

Within one week of completion of the grouting program, submit an as-built sketch showing locations, depths and orientations of drilled holes and any grout pipes left in place.

7.4.6 Materials

7.4.6.1 Chemical Grout

Chemical grout shall consist of a liquid sodium silicate base, reactant, water, accelerator, and other admixtures as required. The Contractor shall design the chemical grout mix so that when injected into standard medium dense sand (Ottawa 20-30) specimens, the unconfined compressive strength of the grouted test sample is no more than 200 psi and no less than 100 psi. The Contractor shall design the trial mix and conduct laboratory tests to verify trial mix meets strength requirements in accordance with ASTM D4219 and D4320.

7.4.6.2 Base Material

The base material for the grout shall be liquid sodium silicate with a specific gravity of 1.4 to 1.5 and a silicate-to-soda ratio of 3.20 to 3.35. The minimum sodium silicate concentration shall be 50 percent of the mix by volume. Sodium silicate shall be delivered in sealed containers, or a certified tank truck, accompanied by the supplier's certificate of origin.

7.4.6.3 Reactant

The reactant shall be an organic base type which, when properly mixed with other grout components, provides a permanent, irreversible gel with controllable gel times. The resulting gels shall exhibit less than 15 percent syneresis in 30 days when mixed with appropriate amounts of sodium silicate, water and accelerator, and shall not exhibit objectionable odors such as ammonia. Sodium bicarbonate, sodium aluminate and other reactants that produce a

temporary grout are not allowed. Reactant shall be delivered in sealed containers, accompanied by the supplier's certificate of origin.

7.4.6.4 Water

Water shall be potable and free of impurities that will deleteriously affect the grout gelling characteristics and strength development of the grouted soil.

7.4.6.5 Accelerator

An accelerator may be utilized if required. It shall be technical grade, water soluble calcium chloride or other approved salt, containing a minimum amount of insolubles.

7.4.6.6 Drilling Equipment

Drilling equipment shall be of the type and capacity suitable for drilling the required hole diameters to the tolerances identified or established by the Contractor through evaluating the potential ground conditions from the Geotechnical Data Report and/or Geotechnical Baseline Report, as applicable. Drilling equipment shall also be able to drill at the approved inclinations and depths for installing grout pipes.

7.4.6.7 Grouting Equipment

Chemical grouting equipment shall have the capacity and mechanical capability to do the work as described herein. The equipment shall be maintained in good operating condition at all times. If grout holes are lost or damaged due to mechanical failure of the equipment, inadequacy of grout supply, or improper injection procedure, the Contractor shall backfill these holes and replace them at no additional cost to the City.

The chemical grout plant shall be a continuous mixing type capable of supplying, proportioning, mixing and pumping the grout with a gel time as specified. Batch-type systems are not permitted. The main pumps shall be equipped with recording, positive displacement meters that will accurately measure the volumes of the various components pumped. Meters shall also be provided at the injection point and at each material line ahead of mixing. The meters shall act independently of the viscosity of the metered fluid. The accuracy of the meters shall be checked at least twice daily.

The pumping unit shall be equipped with piping and/or hoses of adequate capacity to carry the base grout and reactant solutions separately to the point of mixing. The hoses shall be joined using a 'Y' fitting containing check valves to prevent backflow, followed by a baffling chamber. A sampling valve shall be placed beyond the point of mixing and the baffling chamber. The pumping unit shall allow distribution of proportioned grout, under pressure, to the grouting locations monitored by separate, automatic real-time display, flow rate indicators and gauges.

Chemicals shall be stored in metal tanks, suitably protected from accidental discharge. The Contractor shall maintain storage tank capacity sufficient to supply at least one day's worth of grouting materials so as to not interrupt the work if chemical delivery delays occur.

The Contractor shall provide the required chemical quality control testing apparatus on site including, but not limited to: hydrometers, balance scales, graduates, viscometers and other devices required to conduct chemical material acceptance tests, chemical proportioning tests, and grout quality tests for proper quality control of the work.

7.4.7 Grout Pipes

Grout pipes shall be installed horizontally, inclined, or vertically to obtain the specified minimum grout coverage. Grout pipes shall be re-groutable sleeve-port type grout pipes, with grout ports at maximum 15-inch centers covered by expandable rubber sleeves. After being placed in a borehole, the sleeve-port grout pipes shall be encased in a continuous brittle mortar sheath. An internal double packer shall be used to inject grout at a specific sleeve-port.

7.4.8 Preparation

Permeation grouting operations shall not begin until geotechnical instrumentation has been installed as required in Section 7.1 of these Standard Construction Specifications.

Coordinate with all affected utility companies as applicable. Coordinate the sequence of operations taking into consideration: a) means of access to the area; b) permitted areas of operations; c) time restrictions for the performance of the Work; and d) maintenance and adherence to utility traffic requirements.

7.4.9 Installation of Grout Pipes

The Contractor shall locate, protect, support and maintain, without interruption, all utility facilities, equipment and services. Before beginning grout pipe installation from the surface, the proposed grout hole locations shall be marked by the Contractor and cleared by the “on-call” utility notification system. If existing utilities are within 5 feet of proposed grout pipes, the Contractor shall pothole the utilities before installing grout pipes.

Close coordination with the affected utility companies and/or property owners will be necessary when installing grout pipes, in terms of both grout pipe location and the timing of installation.

The minimum extents of the soil zones to be grouted are shown on the Construction Drawings. The intent of the grouting program is to treat granular soil and fill. During drilling, the Contractor should be able to distinguish these granular soils from cohesive soil and fill by drilling action and return of cuttings. Grout pipes shall be installed to the elevations shown on the Construction Drawings or until drilling action indicates that the grout pipes have fully penetrated through the depth of granular soil and fill, whichever is greater.

7.4.10 Grouting Procedures

Using double packers or other approved suitable measures, inject chemical grout into the selected zones through ports in the sleeve pipes. The Contractor shall use soils information gained while drilling grout pipes to manage the grout plan accordingly. The grouting pressure for any one pipe shall not be more than 2 psi per foot of overburden. Adjust injection procedures as required to prevent surface heave. Temporary high injection pressures are permitted to crack open sleeve-ports, but these pressures are not allowed for longer than one minute.

The Contractor shall conduct a surface pressure test of sleeve port grout tube from manifold to injection point (equivalent to maximum depth) to ascertain system pressure loss. This measured pressure is used for estimating appropriate grouting pressures for production grouting. Inject grout at rates not greater than 10 gpm.

The Contractor shall survey surface monitoring points and arrays each day after grouting operations are completed. Ground heaving and settlement shall not exceed monitoring criteria as specified in Section 7.1 of these Standard Construction Specifications.

7.4.11 Leakage Monitoring

The Contractor shall closely monitor the rate of grout take during grout injection, and ascertain the cause of sudden drops in grout injection pressures following initial start-up pressure adjustments. Regularly monitor the ground surface adjacent to the grouting site for leakage. In the event that serious grout leaks are observed, the Contractor shall temporarily terminate injection and plug leaks before resuming pumping. The City's Construction Project Manager shall be informed immediately of such leakage.

If excessive grout take is experienced that is not attributable to leakage, the Contractor shall adjust injection pressure, pumping rates, gel or setting times, or grout composition, subject to the acceptance of the City's Construction Project Manager, to reduce grout use to acceptable levels.

7.4.12 Clean Up and Site Restoration

Remove all equipment, unused materials, and debris from the site at the end of the job. Spilled materials and ground shall be cleaned-up. After tunneling is completed, grout pipes shall be filled with lean cement and cut off within one foot of the ground surface.

Restoration shall follow construction as the work progresses and shall be completed as soon as possible. Restore and repair any damage resulting from heave or spills caused by the work. Any property or improvements damaged or destroyed, shall be restored to a condition equal to or better than existing prior to construction at no additional cost to the City. Restoration shall be completed immediately if a third party or the City is inconvenienced by the damage, and in no case later than thirty (30) days after the damage is discovered. This provision for restoration shall include all property which was affected by the construction operations.

END OF SPECIFICATION



CITY AND COUNTY OF DENVER
ENGINEERING DIVISION

Wastewater Capital Projects Management Standard Construction Specification

7.5 COMPENSATION GROUTING

7.5.1 Definitions

7.5.1.1 Geotechnical Data Report (GDR)

A document that presents an interpretation of the known subsurface data for the project. The purpose of the GDR is to compile all geological, geotechnical, groundwater, and other data obtained from the geotechnical investigations for use by the various participants in the project. If available, this information will be included within the contract documents as specifically applicable to the project.

7.5.1.2 Geotechnical Baseline Report (GBR)

The intent of a GBR is to clearly and contractually define the geotechnical conditions through which tunneling will occur in order to evaluate a differing site condition (if encountered) and it is used as a basis of bid for the contractor. By assessing the anticipated geotechnical conditions for a project and providing baselines in the contract, the contractor has a basis from which to prepare their bid and select their means and methods. The baseline conditions do not necessarily reflect the actual conditions; they are not geotechnical fact to be encountered. Rather, they represent the owner's assumption of existing geotechnical conditions for the project. If available, this information will be included within the contract documents as specifically applicable to the project. Regardless of inclusion, this information shall be investigated, interpreted, verified and/or developed by the contractor prior to commencement of the work.

7.5.1.3 Compensation Grouting

Compensation grouting is a grouting technique utilized to control ground settlement during soft ground tunneling. Compensation grouting involves the injection of a low slump mortar-like grout under high pressure to compact and displace the adjacent soils. The grout does not penetrate soil pores but displaces the subsurface soils by forming a homogeneous grout bulb near the grout pipe tip. Typically, compensation grouting is done after completion of tunneling to correct for settlement. Compensation grouting may also be performed concurrently with the progress of the tunnel while adjusted grouting parameters continually with reference to measured movements of the ground and/or surface structures, to keep settlement and deformations within specified limits.

7.5.2 Section Includes

This item includes settlement mitigation by compensation grouting. All costs for compensation grouting shall be included within the cost of the associated pipeline and no

separate measurement for payment will be made. Within the compensation grouting plan, the Contractor is responsible for design of controls such that bondage between the tunnel pipeline and the compensation grout does not occur and hinder tunnel progression.

7.5.3 Requirements

This work shall consist of installation, monitoring and testing of compensation grouting. It shall be used to mitigate areas of settlement which exceed the limits specified within the Contract Documents.

The Contractor shall provide all labor, materials and equipment to accomplish this work. In addition, the Contractor shall be responsible for all associated costs to comply with City held permits, obtaining additional permits, working within restricted hours and ensuring that all work is coordinated with affected utility companies and stakeholders.

Prior to beginning grout pipe installation, the Contractor shall perform a subsurface investigation to verify the ground conditions above and within the tunnel footprint.

7.5.4 Quality Control

The Contractor shall obtain compensation grout cylinders daily or when the mix design changes. Cylinders shall be 3-inch by 6-inch. Three cylinders shall be taken and marked with the date and time of day collected. Cylinders shall be broken at 7 and 28 days with the remaining cylinder held. Testing shall be performed at a certified laboratory.

The Contractor shall perform slump tests on grout and take measurements of grout mix quantities to verify the grout mix at least twice every shift.

Results of these tests shall be submitted in accordance with these specifications.

7.5.5 Submittals

7.5.5.1 Preconstruction

Submit the following a minimum of 8 weeks prior to mobilization of grouting equipment to allow for review by the City's Construction Project Manager, utility companies and stakeholders:

1. Description of plant, equipment, and materials, including manufacturer's product data
2. The proposed grout mix design, including: the proposed proportions or range of proportions of each constituent including cement, water, fly ash, sand, bentonite and additives; anticipated characteristics when mixed including density, slump or viscosity as appropriate; expected working time after mixing, time to initial set, and time to achieve 75 percent of design strength; and anticipated properties when set including compressive strength and shrinkage. Include field test data from previous projects including the compressive strength and slump achieved.
3. Grouting work plan and shop drawings, describing: the grouting approach; the grout mix design; grout pipe locations, spacing, depth, and orientation; grout pipe installation procedures; grouting equipment including pump and pressure capacity; injection procedures and sequences; proposed injection pressures; recording equipment; data reporting methods; work sequence; schedule; method of monitoring

and protecting existing utilities; testing methods to be used to verify the effectiveness of grouting with respect to strength and acceptance criteria; and any other information necessary to demonstrate compliance with the specified purpose of this grouting work.

4. Work plan for grouting operations to be performed within affected property owner or utility company corridors.
5. If applicable: Layout and location plan of deep settlement monitoring points used to detect settlement above the crown of the tunnel. Include a description of the instrument type and method of installation. Also, proposed method to monitor the ground surface for heave during grouting.
6. If applicable: Layout and location of boreholes for subsurface investigation.

7.5.5.2 During Construction

Record and maintain accurate daily records of all grout pipe installation and grouting quantities, including:

- type of drill rig and drilling method used;
- grout pipe locations and tip elevations;
- grout mix;
- grout quantity injected per stage;
- rate of pumping; and
- beginning and final grouting pressure obtained in each stage

The Contractor shall perform slump tests on grout and take measurements of grout mix quantities to verify the grout mix at least twice every shift. These records shall be submitted on a daily basis within one day of the work being performed. The grout cylinder break results shall be submitted 5 days after test results are available.

Within one week of completion of the grouting program, the contractor will submit an as-built sketch showing locations, depths and orientations of drilled holes.

7.5.6 Materials

7.5.6.1 Cement

Type I or Type II Portland cement (per ASTM C150) free of contamination.

7.5.6.2 Sand

Per ASTM C-33. The fines content shall be greater than 10 percent and less than 30 percent. Natural fines may be supplemented with flyash or bentonite.

7.5.6.3 Flyash

Class C or Class F per ASTM C-618

7.5.6.4 Water

Water shall be potable and free of impurities that will deleteriously affect the grout

characteristics.

7.5.6.5 Compensation Grout Mix

A low mobility, viscous grout with a slump between 1-2 inches. Grout shall be a mixture of cement and water, with the potential addition of sand, which will displace soil under pressure but will not penetrate between soil particles. Bentonite, fly ash, and additives may be included. Slump achieved shall be between 1-2 inches.

7.5.7 Equipment

7.5.7.1 Grout Pipe Drilling Equipment

Furnish drilling equipment as required to install grout pipes at locations, depths, and inclinations indicated on the approved work plan in the soil conditions as described in the Geotechnical Baseline Report or as determined via subsurface investigation by the contractor. Use duplex rotary (self-casing) drills to install all grout pipes, or other system(s) as approved by the City's Construction Project Manager. The system must prevent flow of water from the top of the borehole and prevent ground losses as a result of installation. The use of wash boring techniques is not acceptable.

7.5.7.2 Subsurface Investigation Drilling Equipment

If necessary, the Contractor shall furnish geotechnical drilling equipment as required to advance soil borings along the tunnel alignment to confirm ground conditions prior to compensation grouting.

The geotechnical rig shall be a CME55 or similar, or other equipment approved by the City's Construction Project Manager, such that Standard Penetration N-values and split spoon barrel soil samples can be obtained by the Engineer. The rig shall be equipped with hollow stem augers to facilitate sampling and maintain borehole stability.

7.5.7.3 Hydraulic Jacking System

Provide suitable hydraulic jacking system for withdrawing grout pipes in a controlled manner after completion of compensation grouting.

7.5.7.4 Grouting Pipes

Grout pipes and connections shall be steel casing of adequate strength to maintain the hole and to withstand the required jacking and pumping pressures. The pipes shall be at least 2-inches inside diameter to adequately transmit the specified low slump material without plugging. All casing shall be flush joint threaded or a single piece tubing to provide a smooth inner wall and unobstructed inside diameter. It shall be the Contractor's responsibility to install casing that does not detrimentally impact the grouting procedure.

7.5.7.5 Grouting Equipment

Equipment used shall be specifically designed for compensation grouting. Because of the high pressure involved, all equipment, including hoses, couplings, gauges and pipes, shall be able to safely operate at the maximum grouting pressures as included in Contractor submittals. The mixing and grout pump system shall be designed to provide continuous flow of the grout mixture at variable flow rates and pressures without interruption during any single hookup or stage due to inadequate batching or pump feed capacity.

7.5.7.6 Grout Mixers

The mixer shall be a continuous auger type to ensure complete uniform mixing of the materials used and shall be of sufficient capacity to continuously provide the pumping unit with mixed grout at its normal pumping range. The mixer must be capable of volumetrically proportioning the grout materials. Ready mixed grout is also acceptable with an approved mix design.

7.5.7.7 Grout Pumps

Provide positive displacement grout pump(s) capable of continuously delivering grout at pressures of at least 700 psi or at pressures sufficient to penetrate through previously grouted zones, whichever is larger. Pumping rate shall be readily controllable down to 0.2 cfm. Each grout pump shall be capable of displaying both pressure and injection volume.

7.5.7.8 Grout Delivery System

The grout delivery system shall consist of hoses, couplings, and pipes compatible with the equipment used for this work and shall be capable of withstanding the pressures delivered by the pump. Pressure gauges shall be provided at the pump discharge and at the top of the injection pipe to monitor pressure.

7.5.8 Utility and Stakeholder Coordination

Coordinate with all affected utility companies, stakeholders and property owners within the project limits, as applicable. The Contractor shall locate, protect, support and maintain, without interruption, all utility facilities, equipment and services. Coordinate the sequence of operations taking into consideration: a) means of access to the area; b) permitted areas of operations; c) time restrictions for the performance of the Work; and d) maintenance of traffic requirements.

7.5.9 Installation of Grout Pipes

Before beginning grout pipe installation from the surface, the proposed grout hole locations shall be marked by the Contractor and cleared by the utility notification system. If existing utilities are within 3 feet of proposed grout pipes, the Contractor shall expose the utilities by hand excavation before installing grout pipes. Vacuum excavation may be permitted to expose existing utilities, subject to City's Construction Project Manager's approval.

7.5.10 Compensation Grouting Procedures

The grouting process shall progress in stages within each pipe starting at the bottom of the pipe, progressing upward at 2-foot intervals. The ground surface and adjacent structures will be monitored by the Contractor during grouting, in accordance with the approved work plan. Heave shall not exceed 1/8 inch. Grout injection shall cease at any given stage when surface heave is detected, when the maximum grouting pressure is reached, or when a sudden drop in pressure is noted.

7.5.11 Clean Up and Site Restoration

Remove all equipment, unused materials, and debris from the site at the end of the job. Spilled materials and ground shall be cleaned-up. Grout pipes shall be removed from the ground or filled with lean cement and cut off within one foot of the ground surface in accordance with the requirements of the City, utility owner or stakeholder. Restoration shall follow construction as the work progresses and shall be completed as soon as possible.

Restore and repair any damage resulting from heave or spills caused by the work. Any property or improvements damaged or destroyed, shall be restored to a condition equal to or better than existing prior to construction at no additional cost to the City. Restoration shall be completed immediately if a third party or the City is inconvenienced by the damage, and in no case later than thirty (30) days after the damage is discovered. This provision for restoration shall include all property which was affected by the construction operations.

END OF SPECIFICATION



CITY AND COUNTY OF DENVER
ENGINEERING DIVISION

Wastewater Capital Projects Management Standard Construction Specification

8.0 Structural Excavation

8.0.1 General

All excavation for the construction of structures shall be in conformance with the applicable provisions of CDOT Section 206 except as modified herein.

Unless otherwise stipulated in the Contract Documents, no separate payment will be made for structural excavation, except for overexcavation as directed by the Construction Project Manager, and all costs incurred will be considered to be included in the unit price bid for the associated structure or appurtenance. The cost of overexcavation will be paid for as specified below.

8.0.2 Over Excavation

In locations where soil with unsuitable bearing characteristics are encountered, the Construction Project Manager may order that the unsuitable material be removed and be replaced with granular and/or rock backfill material to provide suitable bearing for the structure.

The overexcavation will be paid for in accordance with the unit price set forth in the Contract Documents for excavation and replacement with an approved granular material; provided, however, no measurement for payment will be made of any material required to fill overexcavated areas: outside of specified pay limits (if applicable), that were for the Contractor's convenience, beyond the limits required for structural excavation, or where excavations for footings, slabs, etc., are made below the required elevations without specific authorization from the Construction Project Manager. Under these circumstances, the excess excavation and backfill required for over excavated area(s) shall be filled in a manner satisfactory to the Construction Project Manager by the Contractor at their expense.

8.0.3 Removal of Water

All water encountered in excavations shall be removed as required within these Specifications.

8.0.4 Backfill

Backfill around structures shall be per the requirements set forth within these Standard Construction Specifications.

8.0.5 Site Grading

The entire site shall be graded using suitable materials from the excavation. Grading shall be for the purpose of providing a neat and pleasing appearance and for facilitating positive drainage. Compaction of all grading material shall be as specified within these Specifications.

End of Specification



CITY AND COUNTY OF DENVER
ENGINEERING DIVISION

Wastewater Capital Projects Management Standard Construction Specification

9.0 Pipe Testing, Inspection and Acceptance

9.1 General

In addition to any other testing or inspection requirements set forth elsewhere in these Specifications, all testing, inspection and acceptance of the completed work will be as specified herein.

Test for water-tightness of sanitary sewers shall be conducted by the Contractor at his own expense, except as noted, with the assistance and under the direction of the Construction Project Manager prior to final acceptance.

Unless otherwise specified, storm sewer systems normally will not be required to be tested for leakage. All leakage tests shall be completed and approved prior to placing of permanent resurfacing. Where the difference in elevation between the inverts of adjacent structures (manholes) exceeds 20 feet, no exfiltration leakage tests will be required.

9.2 Testing and Inspection

9.2.1 Exfiltration Test

Unless otherwise noted on the plans, each section of sewer will be tested between successive manholes by closing the lower end of a sewer reach by plugging the pipe at the inlet to the lower manhole and then by filling the sewer and the upper manhole(s) to the proper level with water. The water level in the upper manhole shall be a minimum of 4 feet above the level of the ground water. The maximum exfiltration rate for any section of sewer line shall not exceed the limits specified below:

Pipe Material	Maximum Rate of Exfiltration
Clay, Concrete	200 gal per day/inch diam/mile
PVC, RPMP	50 gal per day/inch diam/mile

For the purposes of exfiltration leakage, manholes shall be considered to be concrete pipe of the same diameter as the manhole i.e. 48, 60 or 72 inch diameter. Air pocket entrapment shall be avoided when filling the line with water. Once filled with water, the system shall be

allowed to stabilize for a period of one or two hours before starting the test. Exfiltration leakage rate is determined by measuring the amount of water required to maintain a constant level in the upper manhole. Test duration is to be no less than two hours.

If the leakage, as shown by the test, exceeds the allowable value, the Contractor shall make the necessary corrections at his expense to reduce the exfiltration to within the permissible limits. The Contractor shall furnish all water, material and labor required to perform the test. All tests shall be made in the presence of the Construction Project Manager.

9.2.2 Infiltration Test

If the Construction Project Manager determines that excessive ground water is encountered during construction of a sanitary sewer section, the infiltration test for leakage shall be used. The maximum allowable infiltration for sanitary sewers shall not exceed the following limits for the type of projects specified:

Type of Pipe	Max. Allowable Infiltration
Clay, Concrete	200 gal per day/inch diam/mile (3.8 d/inch/100 ft)
PVC, RPMP	50 gal per day/inch diam/mile (0.95 gpd/inch/100 ft)

Unless otherwise specified, infiltration will be measured by the Construction Project Manager, using measuring devices furnished by the City.

If the infiltration is found to exceed the prescribed amount, the Contractor shall make the appropriate repairs as approved by the City and shall continue to test the sewer until it meets requirements.

9.2.3 Air Pressure Test

When directed by the Construction Project Manager and prior to acceptance of any segment of newly constructed sanitary sewers, the pipe will be subjected to an air pressure test, which will be conducted after densification of the backfill and prior to installation of any sanitary taps. The test shall conform to the recommended practice and calculations established by the ASTM C-828. After a manhole to manhole reach of pipe has been backfilled, the line should be flushed and cleaned with the interior walls moist. Plugs shall be placed in the line at each manhole and low pressure shall be introduced into this sealed line until the internal pressure reaches 4 psig (pounds per square inch gage) greater than the average back pressure of any ground water that may be surrounding the pipe. At least two minutes shall be allowed for the air pressure to stabilize. The test shall then be run with the drop in pressure from 3.5 to 2.5 psig. The calculations generated by ASTM C-828 shall then be used to check the adequacy of the pipe installation. If the installation fails to meet the requirements, the Contractor shall at his own expense determine the source of leakage and then shall repair or replace all defective materials and/or workmanship at his own expense to the satisfaction of the Construction Project Manager.

Safety precautions shall be used at all times. It is extremely important that the plugs be installed and braced to prevent blowouts. No one shall be allowed into the manholes during testing.

9.2.4 Television Inspection

Prior to acceptance of any segment of newly-constructed sewers, all pipes will be televised and physically inspected by the City for any observable defects. This requirement will apply to sanitary sewers and to small storm sewers which are too small to be physically inspected will also be televised. Any defects discovered during this inspection shall be corrected prior to acceptance of the sewer.

The Contractor shall request these televised inspections through the City Construction Project Manager with at least 48 hours advance notification. The cost of initial inspection and the first re-inspection to confirm correction of previously identified deficiencies will be borne by the City. If additional inspections are required due to inadequate or otherwise unacceptable repairs, the costs for such inspections shall be charged to the Contractor.

9.2.5 Deflection Test (Flexible Pipe)

The City shall conduct deflection tests of all flexible pipes after completion of the work and again 30 days prior to the end of the guarantee period. The Contractor shall, at his expense, furnish a multiarmed test mandrel having an odd number of arms, nine or more in number. The mandrel will be pulled through the lines to be tested by City personnel using the ASTM testing procedure. The Contractor may witness the tests and may receive a copy of the test logs and reports if desired. All test equipment, calibration data, procedures, etc. shall be subject to approval by the Construction Project Manager.

The maximum allowable deflection after installation and backfilling shall not exceed that specified elsewhere in these Specifications for the particular pipe installed. Any segments of the pipe deemed necessary to be unsatisfactory shall be replaced or reworked by the Contractor in accordance with the requirements of the Construction Project Manager. Such repair shall be at the Contractor's expense.

9.2.6 Hydrostatic Test

Cast Iron, Ductile Iron, PVC Pressure Mains and Force Mains

9.2.6.1 Hydrostatic Tests

Hydrostatic tests consisting of a Pressure Test and a Leakage Test shall be performed prior to final backfilling. Thrust blocks, anchors, and partial backfill sufficient to anchor the pipeline in place but leaving joints, valves and fittings exposed for inspection shall be performed before testing.

9.2.6.2 Pressure Test

After the pipe has been laid and partially backfilled, all newly laid pipe, or any valved section thereof, shall be subjected to a pressure test. The test pressure shall be determined by the Engineer. For PVC Pressure mains and Force Mains the test pressure shall be defined in general accordance with the requirements of AWWA-900 or UNI Bell B-3-77. The duration of the pressure test shall be at least one hour with no discernable loss of pressure.

- a. **Procedure.** Each valved section of pipe shall slowly be filled with water to the specified test pressure, based on the elevation of the lowest point of the line or section under test and corrected to the elevation on the test gage. Air shall be applied by means of a pump connected to the pipe in a satisfactory manner satisfactory to the Engineer. The pump, pipe connections, gages and all necessary test equipment shall be furnished by the

Contractor who will make all taps into the pipe. The Contractor shall furnish all necessary assistance for conducting the tests.

- b. **Air Removal.** Before applying the specified air pressure, all air shall be expelled from the pipe. If permanent air vents are not located at all high points, the Contractor shall install corporation cocks at such points so the air can be expelled as the line is filled with water. After the air has been expelled, the corporation cocks shall be closed and the test pressure applied.
- c. **Examination Under Pressure.** All exposed pipe fittings, valves and joints shall be carefully examined prior to placement of backfill. Any cracked or defective pipe, pipe joints, fittings, or valves discovered in consequence of the pressure test shall be removed and replaced by the Contractor, and the test shall be repeated to the satisfaction of the Construction Project Manager.

9.2.6.3 Leakage Tests

A leakage test shall be conducted after the pressure test has been satisfactory completed. The Contractor will furnish the gage, measuring device, pump, and pipe connections, other necessary apparatus and the necessary assistance to conduct the test. The duration of each leakage test shall be two hours with an average test pressure determined by the Engineer being maintained during this period.

Leakage shall be defined as the quantity of water that must be supplied into the newly laid pipe, or any valved section thereof, to maintain the specified leakage test pressure after the air in the pipeline has been expelled and the pipe has been filled with water.

No pipe installation will be accepted if the leakage is greater than that determined by the following formula:

$$L = ND\sqrt{P} \text{ divided by } 3700$$

For mechanical joints and push-on joints, where L is the allowable leakage in gallons per hour, N is the number of joints in the length of pipeline tested, D is the nominal diameter of the pipe in inches, and P is the average test pressure applied during the test in pounds per square inch gage.

The allowable leakage for 1,000 feet of 18-foot length of mechanical joint or push-on joint pipe at various pressures and diameters is shown in Table 1 of this section.

- a. **Variation from Permissible Leakage.** If any pipe laid discloses leakage greater than that specified above, the Contractor shall, at his own expense, locate and repair the defective joints until the leakage is within the specified allowance.
- b. **Pressure and Leakage Tests after Backfilling.** After the trench has been completely backfilled, the test connections made, and the main filled with water, the pipe shall be subject to a final pressure and leakage test as specified above. If defects are found, the Contractor shall immediately make the repairs and the test repeated until satisfactory to the Engineer.

A final leakage test shall then be conducted after satisfactory completion of the pressure tests. Should any section fail to meet the final leakage test, the Contractor shall make the necessary repairs at his expense.

The duration of the final pressure test and leakage test shall be a minimum of one hour each.

9.2.6.4 Test Report

The Construction Project Manager shall be furnished a written report of the reports of the Hydrostatic Tests performed; identifying the specific length of the pipe tested, the pressure, the duration of the test and the amount of leakage.

9.2 Acceptance

Portions of the work completed may be placed in operation after all cleaning, and inspection requirements have been fulfilled. Final acceptance of the work will not be made until all requirements set forth in the Contract documents have been completed. Any items of work which the Contractor considers as extra shall be reported to the Construction Project Manager during the progress of the testing and inspection. No consideration of any work items will be made unless substantiating records of the work exist. Any work which the Contractor considers to be extra shall be considered in accordance with General Condition 1101, "Change Order".

END OF SPECIFICATION



CITY AND COUNTY OF DENVER
ENGINEERING DIVISION

Wastewater Capital Projects Management Standard Construction Specification

10.1 PRECAST CONCRETE PIPE

10.1.1 General

This section covers material requirements, inspection, marking, delivery, installation, field performance and acceptance of reinforced concrete pipe for storm drainage systems. This shall include circular, elliptical and arch pipe along with all associated special pipe sections.

10.1.2 Referenced Standards

This section references American Society for Testing and Materials (ASTM) Specifications, which are made a part hereof by such references, and shall be the latest edition and revision thereof. All material, manufacturing, operations, testing, inspection and production of concrete pipe shall conform to the following Referenced Standards:

ASTM C14	Concrete Sewer, Storm Drain and Culvert Pipe
ASTM C33	Specification for Concrete Aggregates
ASTM C76	Reinforced Concrete Culvert, Storm Drain and Sewer Pipe
ASTM C150	Standard Specification for Portland Cement
ASTM C361	Reinforced Concrete Low-Head Pressure Pipe
ASTM C443	Standard Specification for Joints for Concrete Pipe and Manholes, Using Rubber Gaskets
ASTM C497	Standard Test Methods for Concrete Pipe, Manhole Sections or Tile
ASTM C506	Reinforced Concrete Arch Culvert, Storm Drain and Sewer Pipe
ASTM C507	Reinforced Concrete Elliptical Culvert, Storm Drain and Sewer Pipe
ASTM C655	Standard Specification for Reinforced Concrete D-Load culvert, Storm Drain and Sewer pipe
ASTM C822	Standard Terminology Relating to Concrete Pipe and Related Products
ASTM C985	Standard Specification for Non-reinforced concrete Specified Strength Culvert, Storm Drain and Sewer pipe
ASTM C1417	Standard Specification for Manufacture of Reinforced Concrete Sewer, Storm drain and Culvert pipe for Direct Design

10.1.3 Diameter of Pipe

The diameter indicated on the Contract Documents shall mean the inside diameter of the pipe.

10.1.4 Wall Thickness and Class of Pipe

The wall thickness and reinforcing steel shall comply with the appropriate ASTM Specification and the designated class of pipe as indicated in the Contract Documents. For jacked pipe, the pipe manufacturer shall supply allowable jacking force calculations for each size of pipe supplied for the project. The Contractor is responsible for ensuring that the allowable jacking force is sufficient to install the product based on anticipated site conditions and the forces that the pipe may be subjected to during jacking operations.

10.1.5 Submittals

10.1.5.1 Supplier Certification

A letter from the supplier to the Construction Project Manager shall be submitted certifying that all Precast Reinforced Concrete Pipe is manufactured in accordance with the applicable ASTM specification.

10.1.5.2 Design Calculations

All designs shall be per the applicable ASTM designation, except where pipe sizes and or special load conditions are not covered in the specifications. All special designs and load conditions shall require the submittal of design calculations through the Construction Project Manager for approval.

10.1.5.3 Shop Drawings

Shop drawings showing a laying diagram and the location of all closure pieces shall be submitted. Drawings shall include: proposed lifting anchors, lugs and any other features pertinent to the manufacture of special sections.

10.1.5.4 Gasket Deformation

Calculations showing the gasket deformation(s) shall be submitted to the Construction Project Manager.

10.1.5.5 Lifting Anchors

The lifting mechanisms proposed for handling and placement of conduit shall be submitted to the Construction Project Manager for approval.

10.1.5.6 Maximum Allowable Joint Gap

The manufacturer shall provide the Construction Project Manager with the maximum allowable joint gaps on all conduit sizes for the project. The maximum allowable joint gap is determined as that point where the bevel of the bell and the shoulder of the spigot are vertically aligned and the rubber gasket has achieved the minimum compression necessary to ensure a water tight seal per these Standard Construction Specifications.

10.1.6 Materials

All precast reinforced concrete pipe shall be manufactured in accordance with the applicable ASTM designation or as specified in the Contract Documents.

The Construction Project Manager shall be provided a production schedule at least three working days in advance of when the various types of pipe will be cast so the casting operation may be inspected and appropriate specimens may be selected for testing in accordance with the Contract Documents.

10.1.6.1 Cement

Unless otherwise specified by the Construction Project Manager, or within the Contract Documents, Type II Portland Cement complying with the requirements of ASTM C150 will be used in the production of concrete pipe.

10.1.6.2 Lifting Anchors

Lifting anchors shall be used on all precast concrete pipe. Lifting holes are only permitted on jack pipe and will require metal sleeves cast through the pipe wall which are capable of accepting threaded caps that are flush with the pipeline interior after installation. Lift hole sleeves shall be filled with a non-shrink grout prior to installing threaded caps.

10.1.6.3 Fittings and Specials

Details of all fittings and specials shall be submitted for approval to the Construction Project Manager prior to construction. Fittings and specials shall be made up of pipe segments having the same structural qualities as the adjoining pipe and shall have the interior treated the same as the pipe, except that epoxy coatings shall be allowed.

10.1.6.4 Joints and Gaskets

Pipe joints for all reinforced concrete pipes shall be formed using rubber gaskets that provide a watertight seal, in accordance with ASTM C443. The joints shall be of such design that they will withstand the forces caused by the compression of the gasket when joined.

The joint design of concrete pipe shall be a bell and spigot or a tongue and groove style joint. The spigot or tongue shall be grooved to properly contain and seat the rubber gasket. The joint assemblies shall be accurately formed so that when each pipe section is forced together in the trench the assembled pipe shall form a continuous watertight conduit with a smooth and uniform interior surface, and shall provide for slight movement of any piece of the pipeline due to expansion, contraction, settlement or lateral displacement. The gasket shall be the sole element of the joint providing water tightness. The ends of the pipe shall be perpendicular (90° angle) to the longitudinal centerline of the pipe, except where bevel-end pipe is required. The ends shall be finished so that they are uniform and smooth.

Rubber gaskets for bell and spigot pipe shall consist of an o-ring rubber gasket, rubber profile gasket, or another gasket specifically approved, in writing, by the Construction Project Manager.

Gaskets may be either isoprene or neoprene conforming to ASTM C443. All gaskets shall be stored in a cool place, preferably at a temperature of less than 70 degrees Fahrenheit (F), and in no case shall the gaskets be stored in the open, or exposed to direct sunlight. No gaskets which show signs of deterioration, such as surface cracking or checking, shall be installed in a pipe joint. When the air temperature is 10 degrees F or lower, the gaskets shall be warmed to temperature of 60 degrees Fahrenheit for a period of 30 minutes before being placed on the pipe.

10.1.6.5 Joint Gap

For reinforced concrete pipe 30-inches (or equivalent diameter for arch and elliptical pipes) and larger, if the end face joint gap is greater than or equal to 65% of the maximum allowable joint gap, as submitted by the manufacturer for each specific pipe size and less any factors of safety, the gap shall be grouted with an approved non-shrink grout product around the entire internal joint perimeter. If the end face joint gap is greater than the maximum allowable joint gap submitted by the manufacturer, at any point around the internal joint perimeter, the adjoining pipe sections will be rejected and no payment will be made.

10.1.6.6 Jacking and/or Microtunneling Pipe

All other Requirements set forth in this specification shall apply to reinforced concrete pipe being installed via tunneling, in addition to the following:

1. All RCP shall have a flush joint design.
2. The class of pipe shall be as defined in the drawings:
 - Where steel joint rings are specified, they shall conform to ASTM C361, joint type R-2 and shall include steel joint rings on the bell and spigot
 - Where steel bell bands are specified, the pipe shall include a ¼” thick steel bell band which is at least 12” wide or twice the manufactured pipe joint depth, whichever is greater. A separate submittal package specific to each pipe size and unique project scenario shall be required for approval by the Construction Project Manager prior to product procurement by the Contractor. At a minimum, this submittal shall include jacking force calculations, additional reinforcement required to meet the site conditions, and a special pipe detail for each situation.
3. Concrete used in Pipe production shall have a minimum 28-day compressive strength of 6,000 psi, regardless of the class of pipe specified.
4. Grouting nipples shall be spaced no more than 8 feet apart on the installed pipeline.

10.1.7 Acceptance

In addition to any deficiencies not covered by the applicable ASTM specifications, individual concrete pipe sections shall be subject to rejection due to any of the following:

1. Surface defects indicating honeycombed or open texture that would adversely affect the function of pipe sections. Repairs may be made, if approved by the Construction Project Manager.
2. Damaged ends, where such damage would prevent making a satisfactory joint.
3. Pipe which has been excessively patched or repaired. The manufacturer may request that the Construction Project Manager perform an inspection at the plant, prior to delivery, to assess patching and/or repair work on conduits. Pipe damaged during shipment or construction may be repaired with the approval of the Construction Project Manager.
4. Exposure of the reinforcement. The exposure of the ends of longitudinals, stirrups and spacers used to position reinforcement shall not be cause for rejection and may be repaired with the approval of the Construction Project Manager, in writing.
5. Concrete pipe that has been delivered to the jobsite prior to being at least 5 days (120 hours) old, except in cases when evidence that design strengths can be met earlier has been submitted and approved by the Construction Project Manager.
6. Broken bells or spigots on installed pipeline

7. Joint gaps greater than maximum allowable submitted by manufacturer

Acceptance of the pipe at point of delivery will not relieve the Contractor of full responsibility for any defects in materials due to workmanship.

10.1.8 Marking

The following shall be clearly marked on both the interior and exterior surface of the pipe:

1. ASTM specification designation
2. Class and size
3. Date of manufacture
4. Name or trademark of manufacturer

10.1.9 Protective Coatings

Whenever adverse corrosive conditions warrant additional interior protection, those pipe segments noted in the Contract Documents shall be lined as specified elsewhere in these Standard Construction Specifications.

10.1.10 Installation

Reinforced concrete pipe shall be constructed continuously, from downstream to upstream, except when otherwise approved by the Construction Project Manager, in writing. The General Contractor is responsible for matching line and grade as shown within the Contract Documents. Bedding material shall be placed in accordance with these Contract Documents and all applicable Wastewater Management Division Standard Details to provide uniform and continuous support.

Pipe shall be placed with the grove or bell end upstream. Each conduit section shall be set into position and checked for line and grade prior to continuing placement. The manufacturers' recommendations shall be closely followed during installation.

The General Contractor shall ensure that all reinforced concrete pipe is kept clean and free from gravel, dirt and debris during and after installation. Precautions shall be taken by the General Contractor to eliminate soil and debris from being washed into the sewer prior to completion of the entire system and its appurtenances. The General Contractor shall incur all costs associated with street failures, cave-ins, system washouts and settlements, and conduit cleaning as a result of carelessness during this timeframe.

End of Specification



CITY AND COUNTY OF DENVER
ENGINEERING DIVISION

Wastewater Capital Projects Management Standard Construction Specification

10.3 Precast Reinforced Box Conduits

10.3.1 General

The work of this section includes furnishing and installing all precast reinforced concrete box conduits for storm drainage systems. This shall include all associated special pieces, except inlets and manholes.

10.3.2 Related Sections

Section 4.0, Utility Trenching and Excavation (Wastewater Capital Projects Management Standard Construction Specifications).

10.3.3 Referenced Standards

This section references American Society for Testing and Materials (ASTM) Specifications, which are made a part hereof by such references, and shall be the latest edition and revision thereof. All material, manufacturing, operations, testing, inspection and production of precast reinforced box conduits shall conform to the following standards.

ASTM C150	Standard Specification for Portland cement
ASTM C497	Standard Test Methods for Concrete Pipe, Manhole Sections, or Tile
ASTM C822	Terminology Relating to Concrete Pipe and Products
ASTM C1433	Standard Specification for Precast Reinforced Concrete Box Sections for Culverts, Storm Drains and Sewers
ASTM C443	Standard Specification for Joints for Concrete Pipe and Manholes, Using Rubber Gaskets

10.3.4 Submittals

10.3.4.1 Supplier Certification

A letter from the supplier to the Construction Project Manager shall be submitted certifying that all Precast Reinforced Box Conduits are manufactured in accordance with ASTM C1433.

10.3.4.2 Design Calculations

All designs shall be per the tables of ASTM C1433 except where box sizes and or special load conditions are not covered by these tables. All special designs and load conditions shall

require the submittal of design calculations through the Construction Project Manager for City and County of Denver approval.

10.3.4.3 Shop Drawings

Shop drawings showing laying diagram and location of all closure pieces shall be submitted. Drawings shall include: proposed lifting anchors, lugs and any other features pertinent to the manufacture of special sections.

10.3.4.4 Gasket Deformation

Calculations showing the gasket deformation(s) shall be submitted to the Construction Project Manager.

10.3.4.5 Lifting Anchors

The lifting mechanisms proposed for handling and placement of box conduit shall be submitted to the Construction Project Manager for approval.

10.3.4.6 Maximum Allowable Joint Gap

The manufacturer shall provide the Construction Project Manager with the maximum allowable joint gaps on all box conduit sizes for the project. The maximum allowable joint gap is determined as that point where the bevel of the bell and the shoulder of the spigot are vertically aligned and the rubber gasket has achieved the minimum compression necessary to ensure a water tight seal per these Standard Construction Specifications.

10.3.5 Materials

10.3.5.1 Box Conduits

All precast reinforced concrete box conduits shall be manufactured in accordance with ASTM C1433.

The Construction Project Manager shall be provided a schedule at least three working days in advance of when the various types of box conduit will be cast so the casting operation may be inspected and appropriate specimens may be selected for testing in accordance with the Contract Documents.

10.3.5.2 Box Joints

Box joints for reinforced concrete box conduits shall be formed using either o-ring or profile rubber gaskets that provide a watertight seal. The gasket shall be properly placed on the spigot using an adhesive, as necessary along the joint perimeter, to maintain the correct position of the gasket. Joints for box conduits shall comply with the requirements set forth in ASTM C443, with the following revisions.

1. Gasket Deformation

The joints shall be of such design that they will withstand the forces caused by the compression of the gasket when the joint is in the assembled and homed position, as well as when the box joint is fully off-centered and the maximum dimensional tolerances are applied.

2. Hydrostatic Testing and Requirements

One box joint per size, for each project, shall be hydrostatically tested at the place of manufacture to verify water tightness and joint integrity. Hydrostatic pressure tests on

joints shall be made on an assembly of two sections of box, properly connected in accordance with the joint design. Suitable means shall be provided that allows pressure to be applied to the joint, either external or internal of the two joined box sections. When infiltration is a concern, the joint shall be tested using external pressure only.

Assembled joints shall pass the following performance tests without leakage at the joints. Moisture or beads of water appearing on the surface of the joint will not be considered as leakage.

Box in straight alignment

Concrete box conduit shall be subjected to a hydrostatic pressure of 5psi (11.5 ft of pressure head) for 10 minutes in straight alignment. If leakage of joints should initially occur, the manufacturer shall have the option to extend the test period up to 24 hours.

Box in maximum deflected position

Upon completion of the test for box in straight alignment, the test section shall be deflected to create a position ½ inch wider than the assembled position on one side of the outside perimeter of each joint and shall be subjected to a hydrostatic pressure of 3psi (6.9 ft of pressure head) for 10 minutes.

3. Joint Gap

If the end face joint gap is greater than or equal to 65% of the maximum allowable joint gap, as submitted by the manufacturer for each specific box size and less any factors of safety, the gap shall be grouted with an approved non-shrink grout product around the entire internal joint perimeter.

10.3.5.3 Closure Pieces

All pieces required for closure between precast and cast-in-place elements shall be fabricated with protruding dowels or exposed reinforcing steel, as shown in the Contract Documents, and as approved by the Construction Project Manager. All dowels and/or exposed reinforcing shall be fully developed.

10.3.5.4 Special Pieces

Special pieces shall be fabricated as shown on the Contract Documents and shall be approved by the Construction Project Manager prior to fabrication.

10.3.5.5 Lifting Anchors

Lifting anchors shall be used on all box conduits. Lifting holes will not be allowed.

10.3.6 Acceptance

In addition to deficiencies covered by applicable ASTM specifications, individual precast reinforced concrete box conduits shall be subject to rejection due to any of the following:

1. Surface defects indicating honeycombed or open texture that would adversely affect the function of box sections. Onsite repairs may be made, if approved by the Construction Project Manager.
2. Damaged ends, where such damage would prevent making a satisfactory joint.
3. Conduit which has been excessively patched or repaired. The manufacturer may request that the Construction Project Manager perform an inspection at the plant, prior to delivery, to assess patching and/or repair work on conduits. Conduit damaged during

shipment or construction may be repaired with the approval of the Construction Project Manager.

4. Exposure of the reinforcement. The exposure of the ends of longitudinals, stirrups and spacers used to position reinforcement shall not be cause for rejection.
5. Box conduit that has been delivered to the jobsite prior to being at least 5 days (120 hours) old.

Acceptance of the conduit shall not relieve the General Contractor of full responsibility for defects in material or workmanship on the completed boxlines.

10.3.7 Marking

The following information shall be legibly marked on each box section by indentation, waterproof paint or other approved means:

1. ASTM specification designation
2. Date of manufacture
3. Name or trademark of manufacturer

10.3.8 Testing

The Construction Project Manager or other identified representatives shall be permitted to visit the manufacturing facility of the General Contractor's supplier to observe compliance with all applicable testing provisions. These visits may be scheduled or random.

10.3.9 Shipping and Handling Box Conduit and Fittings

All conduits, fittings, and specials shall be hauled, unloaded, stockpiled, distributed, handled and installed as recommended by the manufacturer and in such a manner as to prevent damage to the product.

10.3.10 Installation

Box conduit lines shall be constructed continuously, from downstream to upstream, except when otherwise approved by the Construction Project Manager. The General Contractor is responsible for matching line and grade as shown within the Contract Documents. Bedding material shall be placed in accordance with the Contract Documents and applicable Wastewater Management Division Standard Details to provide uniform and continuous support.

Box conduits shall be placed with the grove end upstream. Each conduit section shall be set into position and checked for line and grade prior to continuing placement. The manufacturers' recommendations shall be closely followed during installation.

The General Contractor shall ensure that all reinforced concrete box conduits are kept clean and free from gravel, dirt and debris during and after installation. Precautions shall be taken by the General Contractor to eliminate soil and debris from being washed into the sewer prior to completion of the entire system and its appurtenances. The General Contractor shall incur all costs associated with street failures, cave-ins, system washouts and settlements, and conduit cleaning as a result of carelessness during this timeframe.

End of Specification



CITY AND COUNTY OF DENVER
ENGINEERING DIVISION

Wastewater Capital Projects Management Standard Construction Specification

10.4 Reinforced Polymer Mortar Pipe

10.4.1 General

This section covers material requirements, inspection and testing, marking and delivery, installation, and field performance and acceptance tests of Reinforced Polymer Mortar Pipe (RPMP), for use in gravity, storm and sanitary sewer installations.

10.4.2 Referenced Standards

This section references American Society for Testing and Materials (ASTM), which are made part hereof by such references, and shall be the latest edition and revision thereof. All material, manufacturing, operations, testing, inspection and production of Reinforced Polymer Mortar Pipe (RPMP) shall conform to the following referenced standards:

- ASTM D3262 Standard Specification for “Fiberglass” (Glass-Fiber-Reinforced Thermosetting-Resin) Sewer Pipe
- ASTM D4161 Standard Specification for “Fiberglass” (Glass-Fiber-Reinforced Thermosetting-Resin) Pipe Joints Using Flexible Elastomeric Seals.
- ASTM D2412 Standard Test Method for Determination of External Loading Characteristics of Plastic Pipe by Parallel-Plate Loading.
- ASTM D3681 Standard Test Method for Chemical Resistance of “Fiberglass” Pipe in a Deflected Condition.
- ASTM D638 Test Method for Tensile Properties of Plastics.

10.4.3 Diameter of Pipe

The diameter indicated on the Contract Documents shall mean the inside diameter of the pipe.

10.4.4 Wall Thickness

The wall thickness and reinforcements shall comply with the appropriate ASTM Specification as indicated in the Contract Documents.

10.4.5 Submittals

10.4.5.1 Supplier Certification

1. A letter from the supplier to the Construction Project Manager shall be submitted certifying that all Reinforced Polymer Mortar Pipe and associated appurtenances are manufactured in accordance with the applicable ASTM specifications.

2. The manufacturer shall provide the Construction Project Manager with the manufacturer's recommended maximum allowable joint gaps and tolerances on all conduit sizes for the project.
3. If the project contains tunneling or boring, please refer to additional submittal requirements elsewhere in this specification.

10.4.6 Materials

10.4.6.1 Pipe

The pipe shall meet the ASTM D3262 standard specification Cell Limit Type 1, Liner 2, and Grade 3, with a minimum SN of 46 psi and PN of 25psi, unless otherwise indicated on the plans.

10.4.6.2 Joints

The joints must meet the performance requirements of ASTM D4161. Unless otherwise specified, the pipe shall be field connected with sleeve couplings that utilize elastomeric sealing gaskets made of EPDM rubber compound as the sole means to maintain joint water tightness as otherwise approved by the Construction Project Manager.

The measured pipe joint gap shall not be equal to or larger than 65% of the manufacturer's recommended maximum allowable joint gap.

10.4.6.2.1 Manhole Connection

Unless otherwise specified the connection at the manhole must incorporate a water stop gasket or approved equal.

10.4.6.3 Fittings

Flanges, elbows, reducers, tees, wyes, laterals and other fittings shall be capable of withstanding all operating conditions when installed. They may be contact molded or manufactured from mitered sections of pipe joined by glass-fiber-reinforced overlays. Properly protected standard ductile iron, fusion-bonded epoxy coated steel and stainless steel fittings may also be used.

10.4.6.4 Resin Systems

The manufacturer shall use only polyester resin systems with a proven history of performance in this particular application. The historical data shall have been acquired from a composite material of similar construction and composition as the proposed product.

10.4.6.5 Glass Reinforcements

The reinforcing glass fibers used to manufacture the components shall be of highest quality commercial grade E-glass filaments with binder and sizing compatible with impregnating resins.

10.4.6.6 Silica Sand

Sand shall be minimum 98% silica with a maximum moisture content of 0.2%.

10.4.6.7 Additives

Resin additives, such as curing agents, pigments, dyes, fillers, thixotropic agents, etc., when used, shall not detrimentally affect the performance of the product.

10.4.6.8 Elastomeric Gaskets

Gaskets shall be supplied by qualified gasket manufacturers and be suitable for the service intended.

10.4.7 End Squareness

Pipe ends shall be square to the pipe axis with a maximum tolerance of 1/8”.

10.4.8 Packaging, Handling, Shipping

The Contractor shall follow the procedures and recommendations for packaging, handling, and shipping, in accordance with the manufacturer’s instructions.

10.4.9 Jacking and/or Microtunneling Pipe

All other Requirements set forth in these specifications shall apply to reinforced polymer mortar pipe being installed via tunneling, in addition to the following:

1. All RPMP utilized for Jacking and or Microtunneling shall have a flush joint design.
2. A separate submittal package specific to each pipe size and unique project scenario shall be required for approval by the Construction Project Manager prior to product procurement by the Contractor. At a minimum, this submittal shall include jacking force calculations, joint design, and a special pipe detail for each situation.
3. The pipe manufacturer shall supply allowable jacking force calculations for each size of pipe supplied for the project.
4. The Contractor is responsible for ensuring that the allowable jacking force is sufficient to install the product based on anticipated site conditions and that the forces the pipe may be subjected to during jacking operations do not damage the product.

10.4.4.9 Testing

1. All pipes shall be manufactured and tested in accordance with ASTM D3262
2. All joints shall meet the requirements of ASTM D4161.
3. Stiffness shall be tested in accordance with the test method of ASTM D2412.

10.4.5 Inspection of Product During Manufacturing

10.4.5.1 Customer Inspection

The owner or other designated representative shall be entitled to inspect pipes or witness the pipe manufacturing.

10.4.5.2 Manufacturers Notification to Customer

Should the Owner request to see specific pipes during any phase of the manufacturing process, the manufacturer must provide the Owner with at least 48-hours advance notice of when and where the production of those pipes will take place.

10.4.6 Installation

10.4.6.1 Trenching and Excavation

Trenching and excavation shall be performed in accordance with Section 4.0 of these Standard Construction Specifications.

10.4.6.2 Bedding and Haunching

The bedding shall be Class B as defined in these Standard Construction Specifications. The bedding material shall conform to ASTM C33 or ASTM D448 gradation No. 67 shall be brought to proper grade and elevation prior to installation of pipe and assembly of joints.

Depressions for pipe bell shall be provided. Additional bedding material shall then be placed according to Wastewater Management Division Standard Detail S-301, “Standard Detail for Trenching and Bedding”.

10.4.6.3 Pipe Handling

Use textile slings, other suitable materials or a forklift. Use of chains or cables shall not be permitted.

10.4.6.4 Jointing

1. Clean ends of pipe and coupling components.
2. Apply joint lubricant to pipe ends and elastomeric seals of coupling. Use only lubricants approved by the pipe manufacturer.
3. Use suitable equipment and end protection to push or pull the pipes together.
4. Do not exceed forces recommended by the manufacturer for coupling pipe.
5. Join pipes in straight alignment then deflect to required angle. Do not allow the deflection angle to exceed the deflection permitted by the manufacturer.

10.4.6.5 Minimum Cover

Minimum cover depth of compacted fill above the top of the pipe is three (3) feet. If this minimum cover requirement is not attainable, pipes with higher stiffness (SN 72) shall be used for installation.

10.4.7 Field Testing

10.4.7.1 Infiltration/Exfiltration Test

Maximum allowable leakage shall be per local specification requirements.

10.4.7.2 Low Pressure Air Test

See section 9.2.3

10.4.7.3 Individual Joint Testing

For pipes large enough to enter, individual joints may be air pressure tested with a single or double bladder tester to 5 psi for 1 minute. If the joint fails then the joint shall be repaired per City approved manufacturer’s recommendation.

10.4.7.4 Deflection Testing

A deflection test shall be performed according to section 9.2.5 of these Standard Construction Specifications. The maximum allowable deflection limits after construction shall be 5% of the initial diameter.

END OF SPECIFICATION



CITY AND COUNTY OF DENVER
ENGINEERING DIVISION

Wastewater Capital Projects Management Standard Construction Specification

10.5 Ductile Iron Pipe

10.5.1 General

This section covers material requirements, fittings, field joints and protective coatings for ductile iron pipe.

10.5.2 Referenced Standards

This section references American Society for Testing and Materials (ASTM), American National Standards Institute (ANSI), and American Water Works Association (AWWA), which are made a part hereof by such references, and shall be the latest edition and revision thereof. All material, manufacturing, operations, testing, inspection and production of ductile iron pipe shall conform to the following standards;

ASTM A746	Standard Specification for Ductile Iron Gravity Sewer Pipe
AWWA C110/ANSI A21.10	Standard for Ductile-Iron and Gray Iron Fittings, 3 in. – 48 in
AWWA C111/ANSI A21.11	Standard for Rubber-Gasket Joints for Ductile-Iron Pressure Pipe and Fittings
AWWA C151/ASA A21.51	Standard for Ductile-Iron Pipe, Centrifugally Cast, for Water
AWWA C153/ANSI A21.53	Standard for Ductile-Iron Compact Fittings

10.5.3 Pipe Diameter

The diameter indicated on the drawings shall represent the nominal diameter of the pipe. The inside diameter of the pipe after protective lining has been applied shall not be less than that required for cast iron pipe.

10.5.4 Wall Thickness

The minimum wall thickness and /or pressure class of each section of the pipeline shall conform to that indicated on the Contract Documents, and shall be subject to the approval of the Construction Project Manager.

10.5.5 Grade of Iron

The grade of iron shall be 60-42-10 having a minimum tensile strength of 60,000 psi, minimum yield strength of 42,000 psi, and a minimum percent of elongation of 10 percent.

10.5.6 Fittings and Specials

Fittings and specials shall be ductile iron at least Class 54 thickness and shall be in accordance to the requirements of either AWWA C153/ANSI A21.53 or AWWA C110/ANSI A21.10. Fittings shall be lined as specified in Section 10.5.7a and coated as specified in Section 10.5.7b below.

10.5.7 Field Joints

Mechanical joints shall conform to AWWA C111/ANSI A21.11.

10.5.8 Protective Coatings

Unless otherwise specified. The interior and exterior surfaces shall conform to the following.

1. Interior surfaces shall be lined with calcium aluminates mortar made of fused calcium aluminates cement and fused calcium aluminates aggregates. The thickness of the lining shall be a minimum of 0.125" for 6" through 12" and 0.1875" for 14" through 24" diameter pipe.
2. The lining shall be Sewpercoat® as manufactured by Lafarge Calcium Aluminates or approved equal.
3. Exterior coating shall be a minimum of 1 mil bituminous paint according to AWWA C151/ASA A21.51 - Section 51-8.1.

End of Specification



CITY AND COUNTY OF DENVER
ENGINEERING DIVISION

Wastewater Capital Projects Management Standard Construction Specification

10.6 Polyvinyl Chloride (PVC) Sewer Pipe

10.6.1 General

This section covers material requirements, inspection and testing, marking and delivery, installation, and field performance and acceptance tests of Polyvinyl Chloride (PVC) Sewer Pipe and Fittings for use in gravity, non-pressure, storm or sanitary sewer installations.

10.6.2 Referenced Standards

This section references American Society for Testing and Materials (ASTM), American National Standards Institute (ANSI), and American Water Works Association (AWWA), UNI-Bell PVC Pipe Association (UNI), which are made part hereof by such references, and shall be the latest edition and revision thereof. All material, manufacturing, operations, testing, inspection and production of Poly (Vinyl Chloride) (PVC) sewer pipe shall conform to the following referenced standards:

ASTM C33	Standard Specification for Concrete Aggregates
ASTM D448	Standard Classification for Sizes of Aggregate for Road & Bridge Construction.
ASTM F477	Standard Specification for Elastomeric Seals (Gaskets) for Joining Plastic Pipe.
ASTM F679	Standard Specification for Poly (Vinyl Chloride) (PVC) Large-Diameter Plastic Gravity Sewer Pipe and Fittings.
ASTM F789	Standard Specification for Type PS-46 and Type PS-115 Poly (Vinyl Chloride) (PVC) Plastic Gravity Flow Sewer Pipe and Fittings.
ASTM F794	Standard Specification for Poly (Vinyl Chloride) (PVC) Profile Gravity Sewer Pipe and Fittings Based on Controlled Inside Diameter.
ASTM D2321	Standard Practice for Underground Installation of Thermoplastic Pipe for Sewers and Other Gravity-Flow Applications.
ASTM D3034	Standard Specification for Type PSM Poly (Vinyl Chloride) (PVC) Sewer Pipe and Fittings.
UNI-B-6	Recommended Practice for Low-Pressure Air Testing of Installed Sewer Pipe.

10.6.3 PVC Sewer Materials

The following described materials are approved for use in PVC pipe sewer construction.

10.6.3.1 Pipe and Fittings

Sanitary sewer pipes shall be PVC and conform to: ASTM D3034 SDR 35 for sizes 8 inches to 15 inches in diameter; ASTM F789 for sizes 8 inches to 18 inches (Solid Wall); ASTM F679 for sizes 18 inches to 36 inches (Solid Wall); ASTM F949 for sizes 8 inches to 36 inches (Profile Wall); ASTM F794 for sizes 8 inches to 48 inches (Profile Wall); ASTM F1803 for sizes 18 inches to 60 inches (Profile Wall).

10.6.3.2 Gaskets

Gaskets shall comply with ASTM F477. It shall consist of a properly vulcanized high grade elastomeric compound. The basic polymer shall be natural rubber, synthetic elastomer, or a blend of both. The gasket shall be the only element depended upon to make the joint flexible and water-tight.

10.6.3.3 Lubricant

The lubricant used for assembly shall have no detrimental effect on the gasket or on the pipe. Lubricants shall be in accordance with the manufacturer's recommendations.

10.6.4 Acceptance

Acceptance of the pipe, fittings, and other associated sewer material shall be based on full compliance with these Standard Construction Specifications.

10.6.4.1 Certification

A manufacturer's certification that the material was manufactured and tested in accordance with these Standard Construction Specifications together with a report of all test results shall be furnished at the time of shipment.

10.6.5 Receiving, Storage and Handling

The Contractor shall follow the procedures and recommendation for receiving, storage, and handling contained in the Uni-Bell Plastic Pipe Association, "Handbook of PVC Pipe", and as recommended by the manufacturer.

10.6.5.1 Receiving

Pipes not conforming to the requirements of these Standard Construction Specifications and pipes damaged in transit shall be rejected by the Construction Project Manager. Acceptance of pipes at the time of delivery does not preclude rejection of the installed sewer pipe which do not conform to these Standard Construction Specifications.

10.6.5.2 Storage

Pipe shall be stored in unit packages provided by the manufacturer. The unit packages shall be supported by racks to prevent damage to the underside of the pipe. Supports shall be spaced to prevent pipe bending. Stored pipe shall be covered with an opaque material to prevent exposure to direct sunlight while permitting adequate circulation of the air above and around the pipe to prevent excessive heat accumulation. Pipe determined to have been damaged in storage shall be rejected.

10.6.5.3 Handling

Construction equipment shall be operated in a safe and cautious manner so as to prevent damage to the pipe. Blows to the pipe causing impact damage shall be prevented. Pipe and fittings shall not be thrown, dropped, or dragged.

10.6.6 Installation

Installation of PVC pipe shall be in conformance with ASTM D2321, except where modified by these Standard Construction Specifications.

10.6.6.1 Trenching and Excavation

Trenching and excavation shall be performed in accordance with Section 4.0 of these Standard Construction Specifications.

10.6.6.2 Bedding and Haunching

The bedding shall be Class B as defined in Section 4.0 of these Standard Construction Specifications. The bedding material shall conform to ASTM C33 or ASTM D448 gradation No. 67 as modified and shall be brought to proper grade and elevation prior to installation of pipe and assembly of joints. Depressions for pipe bell shall be provided. Additional bedding material shall then be placed according to Wastewater Management Division Standard Detail S-301, "Standard Detail for Trenching and Bedding".

10.6.6.3 Jointing Pipe

Assembly of all joints shall be in accordance with the recommendations of the manufacturer. Proper jointing may be verified by rotation of the spigot or with a strap wrench. If unusual jointing resistance is encountered or if the insertion mark does not reach the flush position, the joint shall be disassembled, inspected for damage, the joint components recleaned and the assembly steps repeated.

10.6.6.4 Cutting and Beveling Pipe

For shorter than standard pipe lengths, field cuts may be made with plastic pipe cutters. Ends shall be cut square and perpendicular to the pipe axis. Spigots shall have burrs removed and ends smoothly beveled by a mechanical beveler or by hand with a rasp or file. Field spigots shall be stop-marked with felt tip marker or wax crayon for the proper length of assembly insertion. The angle and depth of field bevels and length to stop-mark shall be comparable to factory pipe spigots.

10.6.6.5 Sanitary Sewer Connections

On all new PVC sewer construction, connections shall be made with Wye's or Tee's conforming to ASTM D3034 or F679 whichever is applicable. Only gasketed fittings will be used. Saddle Wye's and Tee's with gaskets for the saddle and joints are approved for sanitary sewer service connection to existing PVC sanitary sewers only. Stainless steel straps shall be used to secure the saddle fittings to the main pipe.

10.6.6.6 Water Stops

Whenever the PVC sewer pipe joints a manhole and is encased by the concrete manhole base or a cutout in precast manhole base, waterstops or seals shall be used. See City and County of Denver, Wastewater Management Division Standard Detail No. S-550.

10.6.6.7 Trench Backfill

Backfilling of the trench shall as specified in Section 5.0 of these Standard Construction Specifications except that no wheeled vehicles shall be used for compaction or other purpose over the installed pipe until the backfill is at least 30 inches thick measured from the top of the pipe to the backfill surface. Mechanical tampers shall not be used until the backfill is at least 48 inches thick. Direct dumping of material over the top of uncovered pipe will not be allowed.

10.6.7 Field Performance and Acceptance Tests

10.6.7.1 Television Inspection

The City will perform a television inspection to verify accuracy of alignment, freedom from debris or obstructions, displacement of gaskets or joints and leaks at joint and service connections. Any of the above discrepancies observed shall be rectified by the Contractor at no cost to the City.

The cost of the initial inspection and the first re-inspection to confirm correction of previously identified deficiencies will be borne by the City. In the event additional inspections are necessary due to inadequate or otherwise unacceptable repairs, the costs for such inspection shall be charged to the Contractor.

10.6.7.2 Air Pressure Test

An air pressure test using the most recent version of UNI-Bell's UNI-B-6 shall be made. The air pressure test outlined in paragraph 9.2.3 of Section 9.0 of these Standard Construction Specifications will not apply to PVC sewer air testing. The Contractor shall secure adequate copies of UNI-B-6, as published by the Uni-Bell Plastic Pipe Association, and provide at least one copy to the Construction Project Manager.

10.6.7.3 Infiltration Test

If the ground water level is above the top of the pipe throughout the length being tested, an infiltration test shall be performed. See paragraph 9.2.2 of Section 9.0 of these Standard Construction Specifications.

10.6.7.4 Deflection Test

A deflection test shall be performed according to paragraph 9.2.5 of Section 9.0 of these Standard Construction Specifications. The allowable deflection limits shall be a maximum of 5% after construction and 6% at the end of the guarantee period. The allowable deflection shall be based on the base inside diameter of the PVC pipe.

10.6.7.5 Reports

Copies of all certified reports and logs of all tests and inspections conducted shall be submitted to the Construction Project Manager.

End of Specification



CITY AND COUNTY OF DENVER
DEPARTMENT OF PUBLIC WORKS, ENGINEERING DIVISION

Wastewater Capital Projects Management Standard Construction Specification

10.7 Cured In Place Pipe

10.7.1 General

This section outlines the guidelines & requirements for the rehabilitation of pipelines and conduits by the Cured in Place Pipe Method (CIPP). CIPP is the installation of a resin-impregnated flexible tube which is inserted into an existing conduit and cured by the use of pressurized steam or circulated water under a hydrostatic head. When complete, the CIPP is continuous and fits tightly to the existing pipe.

10.7.2 Referenced Standards

This section references American Society for Testing and Materials (ASTM) standards, which are made a part of this specification by such reference. All standards shall be the latest edition and revision. The materials, manufacturing, operations, testing, inspection and production of cured in place pipe shall conform to the following standards.

- ASTM D638 Standard Test Method for Tensile Properties of Plastics
- ASTM D790 Standard Test Methods for Flexural Properties of Unreinforced and Reinforced Plastics and Electrical Insulating Materials
- ASTM D2122 Determining Dimensions of Thermoplastic Pipe & Fittings
- ASTM D2990 Standard Test Methods for Tensile, Compressive, and Flexural Creep and Creep-Rupture of Plastic
- ASTM D5813 Standard Specification for Cured-In-Place Thermosetting Resin Sewer Piping Systems
- ASTM F1216-09 Standard Practice and Rehabilitation of Existing Pipelines and Conduits by the Inversion and Curing of a Resin-Impregnated Tube
- ASTM F1743 Practice of Rehabilitation of Existing Pipelines and Conduits by Pulled-In-Place

10.7.3 Submittals

Unless otherwise specified, the Contractor is responsible to have all submittals transmitted to the Construction Project Manager in sufficient time to allow two weeks for review and acceptance prior to starting the construction or any work by the Contractor. These include, but are not limited to:

- CIPP Health and Safety Plan
- Confined Space Entry Permits
- Corrosion Testing.
- Employee Certifications (NASSCO, OSHA, etc.)
- Felt Certification
- Fire Department Permit
- Installation Procedures
- Laboratory Designation and Accreditation
- Laboratory Testing Results
- Liner and Resin Long Term Performance Studies in Post-installation
- Service Open Notice
- Pre-cleaning (and TV) Notice
- Pre-lining Notice
- Pulling force gauge
- Structural Requirements
- Technical Supervision
- Tube Compliance
- Unanticipated Cancellation Notice
- Video/log sheet sample

10.7.3.1 Installation

Prior to installation by Inversion or the Pulled-in-Place method, the Contractor shall provide the Construction Project Manager with the following as applicable to the specific installation method:

- a. The minimum pressure required to hold the tube tight against the existing conduit and the maximum allowable pressure so as not to damage the tube. A complete log of the pressure (or head level) shall be maintained on the site and be furnished to the Construction Project Manager after each installation.
- b. The maximum allowable force that can be used in pulling the tube into the existing pipeline for each size of line. A complete log of the pulling force used for each line shall be maintained on site by the Contractor and be furnished to the Construction Project Manager after each installation.
- c. Minimum temperature and time required for cure on each size of line, based on installation method.
- d. For CIPP segments which are wet out on site, the Contractor must also submit (in spreadsheet form) information on allowable head pressure, roller spacing and gallons of resin to felt length with respect to diameter so the procedure can be verified on site.

10.7.3.2 Health and Safety Plan

Prior to site work, the Contractor shall provide the Construction Project Manager, for review, a Health and Safety Plan which includes (at a minimum) the following:

I) Introduction

- a. Provide project description, the work location and summary of key work activities to be performed.

II) Scope and Applicability

- a. Describe the scope of work for the General Contractor and 1st tier subcontractors performing the work
- b. Detail the planned site activities
- c. Describe who must adhere and abide by the Health and Safety plan
- d. Detail how site visitors will be addressed

III) Key Personnel, Responsibilities and Authority

- a. In relation to Health and Safety, describe the role of project managers, health and safety managers, technical supervisors (10.7.3.4), and other contractor and subcontractor staff.
- b. Provide resumes of Key Personnel, including background and training history.
- c. Identify the name, title, and contact information (phone, email, address) for key personnel.
- d. Identify the name, location, and contact numbers for ambulance, fire, police, hospital, Health and Safety managers (contractor and/or subcontractors), and other key personal or support contacts.

IV) Task/Operation Health and Safety Risk Analysis

- a. Identify, on a task specific basis the individual hazard elements that are present including chemical, physical, and biological.

V) Qualifications and Training Requirements for all Personnel

- a. Detail specific qualifications and training that are required.
- b. Discuss the frequency of safety and training refreshers.
- c. Detail the requirement for site personnel to read and acknowledge, in writing, their understanding of the Health and Safety plan.

VI) Engineering and Administrative Controls

- a. Describe in detail how engineering and administrative controls will be used to protect worker and public safety by preventing chemical exposure, injury, or illness.
- b. List controls in conjunction with each activity identified in the Task/Operation Health and Safety Risk Analysis section above.

VII) Personal Protective Equipment (PPE) Requirements

- a. PPE requirements should be listed in conjunction with each activity identified in the Task/Operation Health and Safety Risk Analysis.
- b. Detail applicable standards (e.g., ANSI, NIOSH, ACGIH, OSHA etc)

VIII) Health and Safety Monitoring

- a. Detail instruments, samples, and monitoring that will occur both on the jobsite and in response to complaint(s) or inquiries.
- b. Detail who is responsible for performing monitoring
- c. Detail frequency of monitoring
- d. Define the appropriate action levels and thresholds
- e. Describe standard operating procedures for Health and Safety monitoring

IX) Site control

- a. Describe work zones, buddy systems, and site security.
- b. Address policies including drug and alcohol policies, personal hygiene requirements, heat and cold stress prevention
- c. Describe task specific site control (e.g., confined space entry protocol, worker photo ID program, etc.)

X) Decontamination plan

- a. Eye and hand wash (if applicable)
- b. Site cleanup

XI) Emergency Contingency Plan

- a. Medical services
- b. Emergency phone numbers
- c. Personnel Injury
- d. Fire/Explosion
- e. Hazardous Material spill response and onsite location of spill kit
- f. Evacuation
- g. Emergency signals and communication
- h. First aid
- i. Emergency equipment list
- j. Map(s), addresses, and phone numbers of nearest medical facilities

XII) Appendices

- a. Safety forms (as needed)
- b. Supporting documentation and information
- c. Material safety data sheets (MSDS)

10.7.3.3 Weekly Installation Schedule

The Contractor shall submit a weekly construction schedule, 7 calendar days in advance of the work, to the Construction Project Manager and the Denver Fire Department to include the following information:

1. The specific line number and related manhole numbers as designated in the project plans. The line length and service connection count information must also be included from the preliminary video investigation.
2. The specific date and timeframe each installation will occur. Night and weekend work must be approved by the Construction Project Manager a minimum of 10 days prior to the proposed commencement of the work.
3. The Technical Supervisor's name for the crew(s) that will be doing each specific installation.
4. The method of installation planned for each line in accordance with ASTM F1216 or F1743.
5. The location and schedule of the "wet-outs" in order to permit inspection of the materials and procedures. This information may be submitted separately.

10.7.3.4 Technical Supervision

Due to the technical aspects and complexity of the products used during the installation of CIPP, the Contractor is required to maintain a full time employee with a minimum of five years experience in the CIPP process of rehabilitation. This employee should be at the superintendent level or higher. This employee must be the direct, first line contact for all aspects of the project construction management. Resume and references, and copies of applicable required NASSCO, OSHA, etc. training certificates of this employee shall be submitted to the Construction Project Manager for review and acceptance prior to the start of the project.

10.7.3.5 Test Results and Performance Studies

CIPP sample test results as well as long term performance studies, from an industry recognized independent laboratory, must be submitted for the materials from the specific supplier(s) to be used on the project in accordance with applicable ASTM standards. The CIPP liner material must meet the requirements of ASTM F1216 or F1743 and ASTM D5813 Sections 6 and 8 (Appendix X.1). The resin shall produce CIPP, which will comply with the structural and chemical resistance requirements of ASTM F1216 or F1743. It is required that CIPP samples with and without polyethylene coating meet these chemical testing requirements. The long term performance studies must show the proposed material consistently meets the required thickness and strength requirements per the Contract Documents.

The Long Term Performance Studies must be submitted and accepted prior to bidding to pre-qualify the prospective bidder. The CIPP liner material used for the project must be the exact same composition of the material used in the Long Term Performance Studies as outlined in this Section. Any deviation in the composition will require that a new Long term Performance Study is completed, submitted and accepted prior to installation.

10.7.3.6 Street Occupancy Permits

The Contractor shall submit, to the Construction Project Manager, copies of the street occupancy permits, including the approved traffic control plans prior to beginning work.

10.7.3.7 Digital Video and Log Sheets

Prior to commencing any site work, the contractor shall submit video quality samples as well as log sheet samples for review and acceptance by the Construction Project Manager. These samples must be in accordance with the following specifications.

10.7.3.8 Digital Video and Log Sheets Specifications

1. After cleaning and lining, the manhole sections shall be visually inspected by means of closed-circuit television. The inspection will be done one manhole section at a time and the flow in the section being inspected will be suitably controlled as specified elsewhere in these Standard Construction Specifications. CCTV inspections shall be performed in accordance with PACP standards including indications of the specific date and time of inspection.
2. The closed-circuit television camera used for the inspection shall be one specifically designed and constructed for such inspection. Lighting for the camera shall be suitable to allow a clear picture of the entire periphery of the pipe. The camera shall be operative in 100% humidity conditions. The camera, television monitor, and other components of the video system shall be capable of producing picture quality to the satisfaction of the Owner's Representative; and if unsatisfactory, equipment shall be removed and no payment will be made for an unsatisfactory inspection.
3. The camera shall be moved through the line upstream to downstream at a moderate rate, stopping when necessary to permit proper documentation of the sewer's condition. In no case will the television camera be pulled at a speed greater than 30 feet per minute. Manual winches, power winches, TV cable, and powered rewinds or other devices that do not obstruct the camera view or interfere with proper documentation of the sewer conditions shall be used to move the camera through the sewer line. If, during the inspection operation, the television camera will not pass through the entire line section, the Contractor shall set up his equipment so that the inspection can be performed from the opposite manhole. If, again, the camera fails to pass through the entire manhole section, the inspection shall be considered complete noted as Survey Abandoned. The contractor is required to notify the Construction Project Manager and further direction will be provided.
4. When manually operated winches are used to pull the television camera through the line, telephones or other suitable means of communication shall be set up between the two manholes of the section being inspected to insure good communications between members of the crew.
5. The importance of accurate distance measurements is emphasized. Measurement for location of defects shall be above ground by means of a meter device. Marking on the cable, or the like, which would require interpolation for depth of manhole, will not be allowed. Accuracy of the distance meter shall be checked by use of a walking meter, roll-a-tape, or other suitable device, and the accuracy shall be satisfactory to the Construction Project Manager.

6. Documentation of the television results shall be as follows:

- (6.1) Television Inspection Logs: Electronic media location records shall be kept by the Contractor and will clearly show the location, by distance in 1/10 of a foot or nearest cm, from the upstream manhole wall, in relation to an adjacent manhole of each infiltration point observed during inspection. In addition, other points of significance such as locations of building sewers (taps), unusual conditions, roots, storm sewer connections, cracks, fractures, broken pipe, presence of scale, calcium deposits and corrosion (with estimated thicknesses), and other discernible features, as defined in the PACP defect codes, will be recorded on electronic media, and a copy of such records will be supplied to the Construction Project Manager.
- (6.2) Digital photographs of the pipe condition and all defects and service connections (taps) shall be taken by the Contractor. Photographs shall be located by distance in 1/10 of a foot or nearest mm, from the manhole wall, in relation to an upstream manhole.
- (6.3) Electronic media recordings: The purpose of electronic media recording shall be to supply a visual and audio record of problem areas of the lines that may be replayed by the Owner. Each original electronic media recording of conditions and defects will be delivered to the Project Construction Manager upon completion of a specific line section.
- (6.4) All CCTV Inspection shall be performed by CCTV personnel who are trained and certified in the use of NASSCO's Pipeline Assessment and Certification Program (PACP)©.

10.7.3.9 Digital Video and Log Sheets Submittal Naming Convention

The Contractor shall submit all log sheets and digital video files for pre and post installation, together, the week immediately following completion of each work segment. All digital video and log sheets must be submitted electronically, *on a USB Plug and Play device (flash drive or hard drive)*. *Video shall be in MP4 format and logs shall be in .pdf format* All video and logs shall be submitted utilizing the following naming convention:

- a. Video Files and Log Sheets
 - i. Named using the following items sequentially, followed by a space
 1. City of Denver Contract Number
 2. Line Number From Plans
 3. GIS Facility ID From Plans (for each line segment.)
 4. Type Of File ('Pre' or 'Post' for Video, 'Pre Log' or 'Post Log' for applicable log sheets)
 5. Extension of file (.mp4 or .pdf)
 - ii. Examples:
 1. 2012XXXXXX Line72 31814SAGM Post Log.pdf
 2. 2012XXXXXX Line72 31814SAGM Post.mp4
 3. 2012XXXXXX Line72 31814SAGM Pre Log.pdf
 4. 2012XXXXXX Line72 31814SAGM Pre.mp4
 5. 2012XXXXXX Line73 31825SAGM Post Log.pdf
 6. 2012XXXXXX Line73 31825SAGM Post.mp4

10.7.4 Materials

10.7.4.1 Textile Tube

1. The tube shall meet the requirements of ASTM F1216 or F1743 and ASTM D5813 Sections 6 and 8. The finished CIPP shall be fabricated from materials which when cured will be chemically resistant to withstand internal exposure to all types of sewage being conveyed. The textile tube shall be continuous in length for the associated run. The wet-out textile tube shall meet ASTM F1216 or F1743, as applicable, have sufficient strength to bridge missing pipe segments and have a uniform thickness that when compressed at installation pressure will equal the specified nominal tube thickness, with a -5% manufacturing tolerance allowed. The tube shall be fabricated to a size that when installed will tightly fit the internal circumference and length of the original pipe. Allowance should be made for circumferential stretching during installation. The minimum length shall be that deemed necessary by the Contractor to effectively span the distance between respective access points, unless otherwise specified. It is the Contractor's responsibility to verify the CIPP lengths and diameters in the field before fabricating the tube.
2. Prior to installation the outside layer of the tube shall be coated with a translucent plastic coated flexible material that clearly allows inspection of the resin impregnation, or wet-out procedure. The plastic coating shall not be subject to delamination after curing of the CIPP. The tube shall be homogenous across the entire wall thickness containing no intermediate or encapsulated elastomeric layers. No materials shall be included in the tubes that are subject to delamination from the cured CIPP.
3. The wall color of the interior pipe surface of the CIPP after installation shall be notably colored as seen in the field install to insure that the resin has been fully impregnated. so that a clear and detailed examination with closed circuit television inspection equipment may be made.
4. The wet-out textile tube shall meet ASTM F1216 or F1743, as applicable, shall have a uniform thickness and 5% to 10% excess resin distribution that when compressed at installation pressures will meet or exceed the design thickness after the cure.

10.7.4.2 Resin

1. The resin/liner system shall conform to ASTM D2990 and ASTM D5813 Section 8.2.2 – 10,000-hour test.
2. The resin shall be a general purpose, unsaturated, styrene-based, thermoset resin and catalyst system or epoxy resin and hardener that are compatible with the inversion or pulled in place process as per the requirements of ASTM F1216 or F1743. The resin shall be tinted so that adequate saturation can be readily observed. Only resin with a minimum long term (50 years) Modulus of Elasticity of 48% of the initial Modulus of Elasticity will be accepted.
3. The tube shall be impregnated with sufficient amount of resin to insure that the resin will be observed on the outer surface of the tube when squeezed. After the tube is

cured, it shall show satisfactory evidence of a fully impregnated tube or the existence of excess resin on the outer surface.

10.7.4.3 Calibration Hose

If a calibration hose is required to be used during the process of the installation of the CIPP, the hose shall be wet and vacuum impregnated with sufficient amount of resin prior to inversion to prevent delamination after the curing of the CIPP. Delaminating or failure of the calibration hose will be cause for rejection or complete removal of the CIPP section at the discretion of the Construction Project Manager.

10.7.4.4 Structural Requirements

1. The CIPP shall be designed as per ASTM F1216, Appendix X.1. The CIPP design shall assume no bonding to the original pipe wall, a fully deteriorated condition, 5% ovality and a conservative groundwater presence over the pipeline. The CIPP cured thickness must meet the required minimum cured nominal thicknesses specified in the table below, or for pipe larger than 18-inches in diameter as specified within the Contract Documents.

Internal Pipe Diameter (inches)	CIPP Minimum Cured Nominal Thickness (mm) Based on Modulus of Elasticity Values	
	Modulus of Elasticity (E) 250,000 psi	Modulus of Elasticity (E) 400,000 psi
8	6	5
10	7.5	6
12	9	7.5
15	10.5	9
18	12.5	10.5
For pipe larger than 18-inches in diameter, the CIPP minimum nominal thickness is specified within the Contract Documents		

2. The layers of the cured CIPP shall be uniformly bonded. It shall not be possible to separate any two layers with a probe or point of a knife blade so that the layers separate cleanly or the probe or knife blade moves freely between the layers; nor shall separation of the layers occur during the required testing.
3. The cured pipe material (CIPP) shall conform to the minimum structural standards, as listed below:

Flexural Stress	ASTM D790	4,500 psi
Modulus of Elasticity	ASTM D790	250,000 or 400,000 psi
Tensile Strength	Pressure Pipe - ASTM D638	3,000 psi

Either of the listed Modulus of Elasticity values noted may be used as long as minimum nominal thicknesses are adhered to in accordance with the table or as noted within the Contract Documents.

10.7.5 Quality Control

It shall be the contractor's responsibility to ensure that the CIPP installed on the project meets all requirements of the Contract Documents and that the final product provided to the City meets all of the City and County of Denver Specifications and is of the highest quality possible.

10.7.5.1 Testing

In the event that the results of any tests do not meet the requirements of the Contract Documents and/or referenced ASTM standards, the Contractor may proceed with the work at his/her own risk and will be required to submit to the Construction Project Manager the proposed changes in the process to meet the required properties of the CIPP.

If any lined pipe segment fails to meet the required properties, the Contractor's attention is directed to General Condition 304 – “Substituted Performance”. At the discretion of the Construction Project Manager and at the Contractor's own expense, the Contractor will be required to remove and replace any lined pipe segment, without damaging the host pipe, or install another liner inside of the liner that failed in order to meet the specified requirements of the Contract Documents

The City may elect at any time to decrease or increase the frequency of these sample and testing requirements.

10.7.5.1.1 On-Site Thickness Testing

A minimum of 2 (two) samples will be collected or 2 locations tested using ultrasonic methods, for on-site thickness at each installation by the contractor. All samples collected for testing shall be restrained with equivalent diameter pipe to match the actual field installed liner. A minimum of eight measurements at evenly spaced intervals around the circumference (internal or external based on method) of the pipe will be made to ensure that minimum and maximum thicknesses have been achieved. For pipe diameters fifteen inches or greater, a minimum of sixteen evenly spaced measurements shall be recorded. Any plastic coatings or CIPP layers not included in the structural design of the CIPP must be deducted from the measured thickness value. The average thickness will be calculated using all measured values and shall meet or exceed the minimum required design thickness. Additionally, the minimum wall thickness measured at any one point around the circumference shall not be less than 87.5% of the specified design thickness as specified within the Contract Documents.

The wall thickness will be measured in accordance with the applicable sections of ASTM D2122 or ASTM E797 and shall incorporate the following, as applicable:

1. For onsite samples collected for testing: A cylindrical anvil tubing micrometer accurate to +0.02 mm (+0.001 inch) will be used. The minimum wall thickness tests will be performed by the Construction Project Manager (or assigned field representative) from the two samples at each installation. All costs associated with providing the required samples shall be borne by the Contractor.

2. For onsite testing using Ultrasonic methods: Testing will be performed by the ultrasonic pulse echo method, in accordance to ASTM E797. Measurements will be taken and calculated at both ends of the pipe run, around the internal circumference of the installed CIPP and at a distance of 12 to 18 inches from the end of pipe, as noted in item 1 above. The ultrasonic method will utilize a flaw detector with A-scan display and a direct thickness readout as defined in 6.1.2 of ASTM E797. A calibration block shall be manufactured from the identical materials used in the installed CIPP to calibrate sound velocity through the liner. Calibration of the transducer shall be performed daily in accordance with the equipment manufacturer's recommendations.

If the deviation in thickness of any one sample is less than 5% (five percent), no payment adjustment will be required. If the deviation in thickness is measured to be between 5%-10% (five percent and ten percent) an adjustment of 10% (ten percent) reduction of the liner unit bid cost will be applied. If the deviation in thickness is greater than 10% (ten percent), the entire run will be rejected and removed and replaced solely at the Contractor's expense.

10.7.5.1.2 Allowable Pulling Force

Prior to installation, the Contractor shall submit to the Construction Project Manager the maximum allowable force, per the material manufacturer, that can be used in pulling the tube into the pipe without rupturing or diminishing the diameter and/or the thickness of the tube. Such pulling force shall be monitored at all times during the installation operation with a gauge that is available for viewing by the City and the tube shall be rejected and removed if the allowable pulling force is exceeded.

10.7.5.1.3 Allowable Elongation of Flexible Tube

Prior to installation, the flexible tube shall be measured and marked equal to the installation run (distance between manholes less one manhole diameter). After the completion of installation, the length of the flexible tube outside of the installation run (face of the manhole to the mark) shall be measured. This length or elongation shall not exceed 3% (three percent) of the original length of measured flexible tube. In the event that this length is exceeded, the entire run length may be rejected and permanently discarded, the Construction Project Manager may order an additional tube to be inserted at no cost to the City, or may accept the elongated tube, but reduce the price paid for the work by 5% (five percent) for every percent elongation above the 3% (three percent) allowable tolerance, as provided by General Condition 304, Substituted Performance. Acceptance will be at the sole discretion of the Construction Project Manager.

10.7.5.1.4 Laboratory Testing

At the start of construction, at least two restrained CIPP field samples will be taken and submitted for laboratory testing. CIPP samples shall be prepared and tested in accordance with ASTM F1216. These samples will be taken by the approved independent lab, with chain of custody documentation regarding each sample.

A CIPP sample is required to be prepared for each installation segment, using one of the following two methods (depending on the size of the host pipe):

1. For pipe sizes of 18 inches or less: the sample will be cut from a section of cured CIPP at an intermediate manhole or at the termination point. If the sample is taken at a termination point the CIPP must have been inverted through a restrained, like diameter pipe which has been held in place by a suitable heat sink, such as sandbags.

2. For pipe sizes greater than 18 inches and areas with limited access: the sample must be fabricated from material taken from the tube and the resin/catalyst system used. This fabricated sample must be cured in a clamped mold which is placed in the down tube (when curing using circulating hot water) or in the silencer (when curing using steam). If approved by the Construction Project Manager, this method can be used for preparing a test sample on any size of CIPP in situations where preparing samples in accordance with section F1216-09, sec. 8.1.1 is not possible due to physical constraints.

Samples must identify the City contract number, project name, line number, date sample was taken and the specified thickness requirement. Testing for cured liner thickness, modulus of elasticity, flexural stress and tensile strength shall be performed by a Certified Independent laboratory approved by the Construction Project Manager. Test results are to be submitted to the Construction Project Manager and all costs of tests shall be included in the related bid price unless specified elsewhere in the Contract Documents. The Contractor shall take samples from the first week's installation and have the short term tests completed and results to the Construction Project Manager prior to application for the first pay estimate. Additional testing will commence at intervals required by the Construction Project Manager.

Additional laboratory testing, at the City's expense, may be requested as frequently as every CIPP installation, at the discretion of the Construction Project Manager. The Contractor will be reimbursed for additional testing at the Contract unit bid price. At the option of the Construction Project Manager any sample taken by the Contractor may be sent to an independent laboratory for similar testing.

10.7.5.1.5 Infiltration Test

If the ground water level is above the top of the pipe throughout the length being reconstructed, the Construction Project Manager, at his/her discretion, may order that an infiltration test be performed. The maximum allowable infiltration shall be 50 gal per day/inch dia/mile (.95 gpd/inch/100 ft.). If the infiltration is found to exceed the prescribed amount, the Contractor shall make the appropriate repairs as approved by the Construction Project Manager. Additional infiltration tests will be performed until acceptable results are obtained.

Unless otherwise specified, infiltration will be measured by a subcontractor specializing in CIPP testing who is mutually agreed upon by the City and Contractor. Payment for this testing is at the City's expense and will be handled by change order.

10.7.5.1.6 Exfiltration Test

In the absence of ground water, the Construction Project Manager, at his/her discretion, may order an exfiltration test be performed in accordance with these specifications. The allowable rate of exfiltration shall be equal to the limits of infiltration stated above. Each section of CIPP will be tested between successive manholes by closing the lower end of a sewer and the upper manhole(s) to the proper level with water. The water level in the upper manhole shall be a minimum of 4 feet above the level of the ground water.

For the purposes of exfiltration leakage, manholes shall be considered to be equivalent length of pipe equal to the diameter of the manhole (i.e. 48, 60 or 72 inch diameter). Air pocket entrapment shall be avoided when filling the line with water. Once filled with water, the system shall be allowed to stabilize for a period of two hours before starting the test.

Exfiltration leakage rate is determined by measuring the amount of water required to maintain a constant level in the upper manhole. Test duration is to be no less than two hours.

If the leakage, as shown by the test, exceeds the allowable value, the Contractor shall make the necessary correction at his expense to reduce the exfiltration to within the permissible limits. The Contractor shall furnish all water, material and labor required to perform the test. All tests shall be made in the presence of the Construction Project Manager.

10.7.6 Public Information and Notification

All written notices shall be issued on current City and County of Denver letterhead templates, prepared in a professional manner and must be approved by the Construction Project Manager prior to distribution. All contact with the Public shall be executed in a business professional manner, including adhering to professional standards regarding courtesy, grooming and maintaining visible/legible photo identification.

1. The Public Information and Notification program shall at a minimum, require the Contractor to be responsible for contacting each home or business affected by the sewer construction and informing them of the work to be done in all of the following ways: Written notice shall be delivered a minimum of 48 hours in advance of the Pre-clean and Video; and again on the day of installation, to each home or business describing the work, schedule, how the construction affects them, and a local telephone number of the Contractor they can call to discuss the project or any problems that may arise.
2. Personally contacting each home and business owner on the day of pre-installation inspection of the sewer and coordinating with that owner the verification of their existing service connection. If the owner is unavailable, other arrangements shall be made for existing service connection verification.
3. In the event that a written notice cannot be left at the home or business, the contractor shall personally contacting each home or business owner the day prior to beginning work on the section of sewer to which they are connected.
4. Personally contacting any home or business owner which cannot be reconnected within the time stated in the Written Notice. Anticipated service tap reconnection time shall be noted within another notice.
5. Provide written notice with the time of reactivation posted on the front door of a residence or business.
6. Upon request by residents and businesses affected by the work, portable toilets shall be furnished and serviced by the Contractor. Reimbursement for the costs of these items will be covered through change order with the Construction Project Manager.
7. Businesses which require special accommodations, such as night or weekend work, must be identified at least 10 days prior to the proposed scheduled work. The Construction Project manager shall be notified and kept apprised of the coordination to meet these special accommodations.

10.7.7 Installation

10.7.7.1 Access Points

The City has shown all existing manhole access points on the Contract Documents, to the best of its knowledge. It is the Contractor's responsibility to fully examine the project site to verify the location of existing manholes and to determine if all manholes are accessible, as necessary for completion of the work. It will be the Contractor's responsibility to notify the Construction Project Manager far enough in advance of the CIPP lining process to allow time for the City to make necessary repairs and provide access to the manholes that are not accessible. The Contractor will reschedule the work as needed so that repair work, either by the City or by the Contractor, can be completed.

10.7.7.2 Pre-Installation Inspection

Inspections of pipelines shall be performed by experienced personnel trained in locating and identifying defects, breaks, obstacles, and service connections by closed circuit television. Certification by NASSCO, PACP program is preferred for inspection personnel. The pre-inspection of pipelines shall also determine active service connections, the addresses served (both visible on the digital recording and audible), as well as which service connections are opened, capped or misaligned. Only active service connection and laterals shall be re-established unless directed otherwise by the Construction Project Manager.

The interior of the pipeline shall be carefully inspected to determine the location of any conditions which may prevent proper installation of the CIPP. It is the Contractor's responsibility to notify the Construction Project Manager of any conditions which may prevent proper installation of the CIPP. These types of conditions shall be recorded and submitted digitally, as described elsewhere in these specifications, to the Construction Project Manager within 5-calendar days of observance, to allow for remedial action and rescheduling of installation for that section of CIPP.

10.7.7.3 Bypassing Sewage

The Contractor shall provide for the flow of sewage around the section or sections of pipe designated for reconstruction. All costs incurred for bypass pumping are included within the "Cured-In-Place-Pipe" bid item within the contract, except when otherwise noted. The bypass shall be made by plugging the line at an existing upstream manhole or adjacent system. The pump and bypass lines shall be of adequate capacity and size to handle the flow with backup pumps onsite. Bypass pumps must be monitored at all times. Leaking equipment will not be permitted. Bypass pumping must be provided for all mainline and service line flows affected by construction. Wastewater shall not be allowed to spill into storm drains, street gutters, or open excavations. Any spills that occur must be addressed immediately and in full conformance with local regulations and requirements. The Construction Project Manager shall be notified immediately and the Contractor shall bear all costs associated with any spills.

10.7.7.4 Cleaning of the Sewer Line

The Contractor shall be required to remove all existing internal debris from the sewer line with the use of water jet, and/or grinding equipment that is accepted by the Construction Project Manager. The cleaning operation shall remove any and all existing debris so that

each pipe joint can be thoroughly inspected and successfully reconstructed or rehabilitated. Excessively hard deposits that cannot be removed by regular cleaning equipment or grinding which require special tools to remove will be paid for negotiated separately by the City.

All sludge, dirt, sand, rocks, grease, and all other solid or semi-solid material resulting from the cleaning operation shall be removed at the downstream manhole of the section being cleaned. Passing material from one manhole section to another shall not be permitted.

All such debris resulting from cleaning operations shall be removed from the site and disposed of in a proper manner. The Contractor shall bear all costs associated with testing of debris and proper dumping. Dumping of the debris shall be in accordance with all local, state, and federal regulations. The City will negotiate for costs associated with material disposal if Hazardous Wastes are encountered during testing.

At the end of each work day, all debris shall be removed from the downstream manhole and from the construction site. No debris shall be left at the construction site unattended by the Contractor. Under no circumstances will the Contractor be allowed to accumulate debris beyond the stated time limit. In the event the Contractor leaves debris unattended at the construction site beyond the stated time, the Contractor will not be allowed to proceed with the work until the debris is properly removed.

During all sewer cleaning operations, precautions shall be taken to protect the sewer lines from damage that might be inflicted by improper use of cleaning equipment. Precautions shall be taken to ensure that the cleaning operation will not cause any damage or flooding to public and/or private property being served by the sewer line section involved. The Contractor shall bear all costs associated with flooding, damage to basements or structures, adjacent utilities and the City's sewer.

10.7.7.5 Line Obstructions

It shall be the responsibility of the Contractor to clear the line of obstructions such as solids and roots that will prevent the installation of the CIPP. If the pre-installation inspection reveals an obstruction such as a protruding service connection, dropped joint, collapse or obstruction that will prevent the rehabilitation process and cannot be removed by conventional sewer cleaning equipment, grinding or extended tap cutting, then the Contractor shall notify the Construction Project Manager immediately. These conditions shall be recorded and a digital video file and log sheet must be submitted to the Construction Project Manager so that the existing conditions are documented and may be reviewed to determine the extent of repair required prior to CIPP installation. The Construction Project Manager will notify the Contractor upon completion of required repair(s), at which time the Contractor shall perform sewer line cleaning and a pre-installation inspection prior to CIPP installation.

10.7.7.6 Methods

All bidders proposing to use the CIPP process for a project must use a method that has been approved by the City prior to bid opening. All approved CIPP methods must meet these Standard Construction Specifications. Any proposed deviation from these Standard Construction Specifications must be submitted in writing for acceptance at least eight calendar days prior to the bid opening. CIPP installation shall be in accordance with ASTM F1216, Section 7 for the Inversion Method, or Section 6 of ASTM F1743 for the Pulled-In-Place Installation Method, with the following requirements:

1. The Contractor shall designate a location where the tube will be impregnated prior to installation. The Contractor shall notify the Construction Project Manager of proposed “wet-outs” in order to inspect the materials and procedure. A resin and catalyst system compatible with the requirements of this method shall be used.
2. Once inversion has started, the pressure shall be maintained between the minimum and maximum pressures, as set by the liner’s manufacturer, until cure completion. A continuous, constant pressure must be maintained for all air inversion steam cure (AISC) installations. If pressure is lost at any time during installation/cure (for inversion or pulled in place methods), the City may request that the CIPP product be removed and the line segment re-inspected, at the contractor’s expense, prior to allowing re-installation and curing.
3. The Contractor shall pull or invert the flexible tube through the existing sewer line in a method which has been reviewed and approved by the Construction Project Manager. The Contractor will not be allowed to use water to float the inserted flexible tube into the existing sewer line. Immediately after installation of the tube, a heat source will be applied to start the curing process. Constant pressure shall be maintained until the tube has completely cured out with continuous monitoring of the confined space during the curing procedure to ensure that the LEL is not exceeded.
4. The heat source shall be fitted with suitable monitors to gauge the temperature of the incoming and outgoing heat supply. Another such gauge shall be placed at the remote manhole to determine the temperature at that location during cure. The Contractor must maintain an on-site written log during the CIPP curing process for each installation, tracking temperature, pressure (for steam cure) and curing time. This log must be available for review at any time by the Construction Project Manager. If air pressure and steam are used, a Safety Gas Detector shall be used to ensure that it does not reach the explosive limit.
5. As noted within the submittals portion of this specification, before the installation process begins, the Contractor shall submit to the Construction Project Manager, the minimum pressure required to hold the tube tight against the existing conduit (including considerations for external ground water pressure, if present) and the maximum allowable pressure to avoid damaging the tube. This data shall be obtained by the Contractor from the tube manufacturer.

If the CIPP is installed via inversion, the pressure shall be maintained between the minimum and maximum pressures until the entire operation has been completed (inversion and cure). If the CIPP is installed using the pulled-in-place method, the pressures shall be maintained, after initial inflation, between the minimum and maximum pressures until the entire operation has been completed (inflation and cure).

If the pressure drops below the recommended minimum at any time during installation or curing of the CIPP, the liner should be removed and the host pipe re-inspected for dislodged pipe fragments or fallen debris which may cause bulging or protrusions within the cured CIPP. In addition, under the above circumstances, the CIPP product should be inspected for lifts or delaminations and evaluated for its ability to fully meet the applicable ASTM F1216 and F1743 requirements. Should the pressure deviate from within the range of minimum and maximum pressures, the installed tube may be rejected

and the Contractor will be responsible for the removal of the CIPP without damage to the host pipe and replacement with new CIPP at no additional cost to the City.

Once the cure has started and dimpling for laterals is completed, the required pressures shall be sustained until the cure has been completed. A complete log of the pressures shall be maintained on the site and furnished to the Construction Project Manager after each installation.

6. The plastic coating of the tube shall be translucent to allow visual proof that the resin has wet out the entire tube and that there are no dry areas.
7. The Contractor shall maintain a log on site for each installation section documenting elongation, thickness and pulling force. These logs shall be submitted weekly to the Construction Project Manager.
8. The finished CIPP shall be continuous over the entire length of an installation run between two manholes and be free, as commercially practicable, from visual defects such as foreign inclusions, dry spots, pinholes, folds and delamination.
9. If the CIPP fails to make a tight seal at each manhole, the Contractor shall apply Hydrophilic Seals. The Contractor shall provide a submittal to the Construction Project Manager for approval on either a gasket or a non cementitious (epoxy) grout.
10. Individual installation runs can be made over one or more manhole sections as determined in the field by the Contractor. The maximum allowed installation run is 1,200 feet. Intermediate manholes will be reopened as directed by the Construction Project Manager.

10.7.7.7 Sewer Service Connection and Reactivation

The Contractor shall determine if a service connection is active prior to rehabilitation of the sewer. Only active service connections and laterals shall be re-established. All costs incurred to verify active service connections are included within the “Cured-In-Place-Pipe” bid item within the contract. No additional payment for verification shall be considered.

After the curing of the CIPP has been completed, the Contractor shall reopen and restore the existing active service connections and branch connections. It is the intent of these Standard Construction Specifications that the active service connections and branch connections be reopened without excavation. When the pipe size is too small to facilitate direct manned reactivation, a remotely controlled cutting device, monitored by a close circuit television camera shall be used. The cutting device is required to re-establish service connections to not greater than 100% (one hundred percent) capacity, and not less than 95% (ninety five percent) capacity, while conforming to the shape of the existing opening. A smooth, or brushed, surface is required to prevent debris or solids from accumulating at the opening. Perforated services connections will be considered damaged and will need to be repaired. The Contractor shall be responsible for completing point repairs of any active service connections that are damaged or misaligned during reactivation procedures. These point repairs shall be completed as directed and approved by the Construction Project Manager and all costs shall be borne by the Contractor.

The Contractor shall certify he/she has a minimum of 2 (two) complete working cutting devices, plus spare key components on the site before each installation.

All solid or semi-solid material resulting from reactivation of the service connection or manhole cut outs shall be removed at the downstream manhole of the section being reactivated. Passing material from one manhole section to another shall not be permitted.

Service connections shall not remain out of service for more than 12 hours at a time, without the Contractor providing some means of temporary facilities or hotel accommodations for the affected residents or property owners.

10.7.8 Post Installation Inspection

Post installation video inspection of all CIPP line segments shall be completed by the contractor and recorded using closed circuit television in accordance with ASTM F1216 or F1743. The post inspection of pipelines shall be performed in a manner which allows the invert to be clearly viewed and inspected (i.e. no water flow). The recorded video must show that all active service connections have been reactivated, the addresses served (both visible on the digital recording and audible), as well as any inclusions or visual defects present. All service connections and laterals which are not plugged or capped shall be re-established unless directed otherwise by the Construction Project Manager. The contractor shall review all post inspection videos and notify the City immediately of any visual defects, inclusions, or issues with the installation. Digital video records shall be submitted, as specified elsewhere in these standards.

10.7.9 Clean-Up

The Contractor shall reinstate all project areas affected by their operations to an equal or better condition than existing upon completion of the CIPP installation. All restoration must be completed prior to submitting that section of CIPP for consideration for payment.

10.7.10 Record Documentation

1. Digital Video and Log Sheets

The Contractor is required to provide pre and post video files, as well as associated log sheets, for all pipe segments rehabilitated under the contract. All video and log sheets must be submitted to the City and County of Denver. All digital video files shall be submitted in .mp4 format and log sheets shall be submitted in .pdf format. All files will be labeled in accordance with the instructions provided by the Construction Project Manager.

Pre and post inspection log sheets and digital video should be submitted together the week immediately following completion of each work segment, unless the contractor is submitting pre-inspection results separately to convey potential problem areas to the Construction Project Manager. Log sheets and digital video files not submitted at least 5 business days prior to a pay estimate cut-off date will not be considered for payment until the following month. It is the Contractor's responsibility to submit digital video media and log sheets in a timely fashion and as outlined in these specifications.

2. Redline Drawings

A final set of red-lined drawings shall be submitted by the Contractor on a clean, full size set of project plans for As-Built creation purposes prior to processing final payment and releasing remaining retainage. A .pdf copy of a clean set of project plans may be obtained from the Construction Project Manager upon request.

The red-lined drawings shall include the following: location and size of all pipe segments rehabilitated, the location of all restored service connections (showing distances from the downstream manhole), and the field recorded length of each rehabilitated segment (face of manhole to face of manhole). Providing inaccurate or incomplete record information is reason for withholding of progress payment as outlined in the General Contract Conditions.

10.7.11 Patents

The Contractor and the Contractor's suppliers shall warrant and save harmless the City against any and all claims, potential litigation involving patent infringement, copyright violations and any loss thereof.

End of Specification



CITY AND COUNTY OF DENVER
ENGINEERING DIVISION

Wastewater Capital Projects Management Standard Construction Specification

10.20 Pipe Bursting

10.20.1 Intent

It is the intent of this specification to provide for the replacement of existing pipelines and conduits by bursting or crushing the existing pipeline and replacing it with either the same size or larger diameter pipe.

10.20.2 Methods

All bidders on this project must construct the Trenchless Replacement of Sanitary Sewers with a process that has been approved by Wastewater Capital Projects Management prior to bid opening.

All approved methods must meet these Standard Construction Specifications. Any proposed deviation from these Standard Construction Specifications must be submitted in writing for acceptance at last ten (10) calendar days prior to the bid opening. Any and all departures from these Standard Construction Specifications must be pointed out and shown on the material submitted.

Special Condition SC-8, **Substitution** of these Specifications refer to substitution of processes other than herein approved.

10.20.3 Inspection of Pipelines

Inspections of pipelines shall be performed by experienced personnel trained in locating breaks, obstacles, and service conditions by closed circuit television. The inspection of pipelines is also to determine active service connections and the addresses which they serve. A videotape and suitable log shall be kept for later reference by Wastewater Capital Projects Management.

10.20.4 Public Relations

The Public Information and Notification program shall as a minimum require the Contractor to be responsible for contacting each home or business connected to the sanitary sewer and informing them of the work to be done, and when the sewer will be off-line and the following:

10.20.4.a

Written notice to be delivered to each home or business describing work, schedule, how it affects them, and a local telephone number of the Contractor they can call to discuss the project or problems.

10.20.4.b

Personal contact on the day of pre-installation inspection of the sewer. Each lateral shall be verified by having the homeowner run water down their drain. If the homeowner is unavailable, other arrangements shall be made to drain water through the lateral.

10.20.4.c

Personal contact and written notice the day prior to beginning work on the section of sewer to which they are connected.

10.20.4.d

Personal contact with any home or business which cannot be reconnected within the time stated in the written notice.

10.20.4.e

If so required by a served business, portable toilets for their use by their employees will be furnished and serviced by the Contractor. The costs of these items are considered to be included in the cost of CIPP. No additional payment will be made by the City.

10.20.4.f

The Public Information and Notification Program shall include the minimum of the above. A complete program shall be submitted in writing to the Construction Project Manager.

10.20.5 Approved Material for Trenchless Replacement of Sanitary Sewers

10.20.5.a Materials

High Density Polyethylene Pipe (HDPE) shall conform to requirements of Type III, Class C, Category 5, Grade P34 as defined in the latest revision of ASTM D-1248. All solid wall HDPE pipe and fittings shall be manufactured in accordance with ASTM F-714. Pipe and fittings shall be made from virgin high density plastic compounds, with no rework compound except that obtained from the manufacturer's own production of the same formulation, which comply with the requirements for a minimum cell classification of PE 345434C as defined by ASTM D-3350. HDPE pipe shall have an inside surface in light color (e.g. natural, white, green, etc.) to allow light reflection for television inspection.

10.10.5.b Physical Properties

Pipes, fittings and joints shall meet the following minimum requirements at the time of installation:

Density	0.941 gm/cc	ASTM D-1505
Melt Index	< 0.15 gm/10 min.	ASTM D-1238
Initial Flexural Modulus	110,000 psi	ASTM D-790
Long-Term Flexural Modulus	28,200 psi	Continuous load duration of 50 years at design load conditions, certified by manufacturer.
Initial Flexural Strength	3,000 psi	ASTM D-790
Long-Term Flexure Strength	1,500 psi	Continuous load duration of 50 years at design load conditions, certified by manufacturer.
Environmental Stress Cracking Resistance	F20=192	ASTM D-1693, Test Condition C (failure % = hours).
Hydrostatic Design Basis	1,600 psi	ASTM D-2837
Color & Ultraviolet Stabilizer	Black, with 2% carbon black	ASTM D-3350

Certification

Manufacturer shall provide certification that the pipe and fittings meet the minimum specified physical properties, and has sufficient ultraviolet stabilizer for a minimum two (2) years storage life.

Workmanship

The pipe and fittings shall be homogeneous throughout and free of any blemishes, wrinkles, ribs, protrusions, holes, visible cracks, foreign materials, blisters or other deleterious faults or any defects.

10.20.5.c Joints

Sections of HDPE pipe shall be assembled and joined on the job site. Jointing shall be accomplished by the heating and butt-fusion method in strict conformance with the manufacturer's printed instructions. It is the sole responsibility of the Contractor to provide an acceptable water-tight butt-fusion joint. Joint strength shall be equal to or greater than the pipe and shall indicate a ductile rather than brittle fracture when tested. If sectional HDPE pipe is used, it shall be joined in accordance with the manufacturer's recommendation for a leakproof, stab joint method using EPDM O-ring synthetic elastomer gaskets.

Where excavations for HDPE pipe installation are made between manholes, pipe ends shall be jointed by butt-fusion joints, or when recommended by the pipe supplier, with a full circle seal clamp made of stainless steel hardware and a rubber sleeve. Seal clamps shall be manufactured by Rockwell, Dresser, or approved equal. The minimum clamp length shall be fifteen inches (15”).

10.20.5.d Saddles

Reconnection of service laterals to installed HDPE pipe shall be accomplished using heat fusion saddles. Heat fusion saddles shall be made of polyethylene pipe that meets the minimum specified physical properties and is suitable for fusion welding. Fusion saddles shall be Branch Saddle as manufactured by Driscopipe®, Miller®, Dupont®, or approved equal.

10.20.5.e Flexible Couplings

Connections to existing service laterals shall be made using flexible couplings. All flexible couplings shall conform to ASTM C-425 and shall be as manufactured by Fernco® Joint Sealer Co., DFW® Plastics, Inc., or approved equal.

10.20.5.f Restrained Joint Polyvinyl Chloride (PVC) Pressure Pipe

10.20.5.g Material

Restrained Joint PVC Pressure Pipe shall conform to the requirements of the latest revision of ASTM D-2241. All restrained joint PVC pipe and fittings shall be manufactured from a specially formulated PVC compound which contains impact modifiers and ultraviolet inhibitors. In accordance with ASTM D-1784, all pipe and fittings shall be made from a compound utilizing Type 1, Grade 1, 2000 psi hydrostatic design stress material, Class 12454-B.

10.20.5.h Physical Properties

Pipe, fittings and joints shall meet the following minimum requirements at the time of installation:

Izod Impact	1.15 ft-lb./in. of notch	ASTM D-256
Tensile Strength	7,000 psi	ASTM D-638
Modulus of Elasticity	40,000 psi	ASTM D-638
Deflection Temperature	158° F	ASTM D-648
Chemical Resistance	B	ASTM D-543
Elongation	150%	ASTM D-638
Flammability	Self-Extinguishing	ASTM D-635

Certification

Manufacturer shall provide certification that the pipe and fittings meet the minimum specified physical properties.

Workmanship

The pipe and fittings shall be homogeneous throughout and free of any blemishes, wrinkles, ribs, protrusions, holes, visible cracks, foreign materials, blisters or other deleterious faults or any other defects.

10.20.5.i Joints

Sections of PVC pipe shall be assembled and permanently joined on the job site. Jointing shall be accomplished by use of machined grooves on the pipe and in the joining coupling which, when aligned, allow a spline to be inserted, resulting in a fully circumferential restrained joint that locks the pipe and couplings together. A flexible elastomeric seal (O-ring) in the coupling provides a hydraulic pressure seal.

Joints shall meet the requirements of ASTM D-3139, and the O-rings shall meet the requirements of ASTM F-477. Couplings shall be provided with factory installed O-rings.

10.20.6 Bypassing Sewage

The Contractor shall provide for the flow of sewage around the section or sections of pipe designated for reconstruction. The bypass shall be made by plugging the line at an existing upstream manhole or adjacent system. The pump and bypass lines shall be of adequate capacity and size to handle the flow. Bypassing includes all mainline and service line bypassing required. Wastewater shall not be allowed to spill into storm drains, street gutters, or open excavations. Any spills that occur must be taken care of properly and immediately. The City shall be notified immediately and the Contractor shall bear all costs associated with any spills.

10.20.7 Service Connections

After the trenchless replacement of the pipe has been completed, the Contractor shall reopen / restore the existing active service connections and branch connections. No service connection shall remain out of service for more than twenty-four (24) hours at a time without the Contractor providing some means of temporary facilities or hotel accommodations for the residents.

No additional payment will be made for excavations for the purpose of reopening connections and the Contractor will be responsible for all costs and liability associated with such excavation and restoration work.

10.20.8 Reports

The Contractor will provide the Construction Project Manager with a color videotape. The tape will include both the before and after conditions, and restored connections with addresses each connection serves, in audio, and on the videotape. Copies of all certified reports and logs of all tests and inspections conducted shall be submitted to the Construction Project Manager.

10.20.9 Clean-up

Upon acceptance of the installation work and testing, the Contractor shall reinstate the project area affected by this operation.

10.20.10 Payment

Payment for work included in this section will be in accordance with the prices set forth in the proposal for the quantity of work performed. Progress payments will be made monthly based on the work performed during that period.

10.20.11 Patents

The Contractor and the Contractor's supplier shall warrant and save harmless the City and Wastewater Management Division against any and all claims and potential litigation involving patent infringement and copyright violations and any loss thereof.

End of Specification



CITY AND COUNTY OF DENVER
ENGINEERING DIVISION

Wastewater Capital Projects Management Standard Construction Specification

11.0 Structures and Appurtenances

11.0.1 General

Except where otherwise indicated in these Standard Construction Specifications, manholes, special structures, box culverts, vaults, storm inlets, and other miscellaneous structures and appurtenances shall conform to the details included in these Specifications or as shown on the drawings. All concrete and reinforcing for structures shall conform to the requirements set forth in the most recent Standard Specifications for Road and Bridge Construction, by the Colorado Department of Transportation, as described below, or otherwise modified herein.

1. CDOT Section 601 Structural Concrete

CDOT Section 601 Structural Concrete shall be utilized and revised as follows:

Class D Concrete will be utilized for all structural concrete work; using $\frac{3}{4}$ " nominal sized aggregate (100% passing the 1" sieve and 90% to 100% passing the $\frac{3}{4}$ " sieve).

Type II Portland Cement will be used.

Subsection 601.05 shall be revised to include:

The concrete used in upper deck slabs shall have a maximum substitution of fly ash for Portland cement of 10% by weight.

CDOT Subsection 601.19 shall be revised as follows:

Method of measurement shall be deleted. Method utilized will be as specified elsewhere in the Contract Documents.

Subsection 601.20 shall be revised as follows:

Basis of payment will be deleted. Basis of payment utilized will be as specified elsewhere in the Contract Documents.

2. CDOT Section 602 Reinforcing Steel

CDOT Section 602 Reinforcing Steel shall be utilized and revised as follows:

Subsection 602.02 shall be revised as follows:

Epoxy coated reinforcing steel will not be utilized unless otherwise specified in the Contract Documents.

Subsection 602.07 shall be revised as follows:

Method of measurement will be deleted. Method utilized will be as included otherwise in the Contract Documents.

Subsection 602.08 shall be revised as follows:

Basis of payment will be deleted. Basis of payment will be as included otherwise in the Contract Documents.

11.0.2 Manholes

Except where otherwise specified or indicated on the drawings, storm and sanitary sewer manholes shall conform to the requirements as set forth below. Manholes 6' (six foot) in diameter or smaller shall be constructed of precast concrete or cast-in-place concrete as outlined in the Wastewater Management Division Standard Detail Drawings or within the Contract Documents. Type B and Type P manholes shall be cast in place only, unless specified otherwise in the contract documents. All manholes and related component items shall be designed for AASHTO HS20 loading.

11.0.2.1 Size

The minimum internal diameter of the manhole barrel shall be as follows for both storm and sanitary sewer installations (please refer to the Wastewater Management Division Standard Detail Drawings).

Pipe Size	MH Barrel I.D.	Standard Top Section	Standard Detail
30" dia. and smaller	4'-0"	Concentric Cone	S501.1
30" to 36"	5'-0"	Concentric Cone	S501.1
42" and larger	Type B or P or Special Detail	As detailed	S503 S504

Note: Standard ring and cover is 24 inch diameter.

11.0.2.2 Materials

The materials to be used in the construction of sewer manholes shall conform to the following requirements:

1. Precast Reinforced Concrete Manhole Sections

Precast manhole sections including barrels, cones, flat tops, etc. shall be manufactured in accordance with ASTM C-478, Precast Reinforced Concrete Manhole Sections. All cones furnished shall be concentric except for manholes with less than 4 feet of cover, which shall be flat top. Concrete used in precast manhole bases shall have a minimum 28 day compressive strength of 5000 psi, and shall be constructed of Type II, Portland cement. Welded wire fabric used in precast manhole sections shall be as specified in ASTM C-478. These precast manhole elements are intended to be utilized as components of non-pressurized sewer and manhole systems only. Pressure systems were warranted and authorized by the Division will require special design pressure manholes, joints, and other appurtenant items.

2. Cast-in-Place Concrete Manholes

All concrete used in construction of cast-in-place manholes and bases shall be CDOT Class D. Construction shall be in conformance with the Wastewater Management Division Standard Detail Drawings.

3. Structural Reinforcement

All structural reinforcement shall be placed in accordance with the Wastewater Management Division Standard Detail drawings and in conformance with this specification.

4. Frame and Cover

Unless otherwise noted on the drawings, frame and covers for manholes and special structures shall be the current Denver Standard pattern, manufactured by an approved foundry. Castings shall, at the minimum, meet the requirements of ASTM A48, Class 35B, and other Agency requirements as a condition of approval. Horizontal bearing surfaces of all rings and covers shall be machined to eliminate any rocking action or non-uniform bearing. Castings shall not be dipped or painted prior to field inspection and acceptance. Refer to the Wastewater Management Division Standard Detail Drawings for additional requirements.

5. Manhole Steps

Manhole steps shall be required for all new manholes greater than 4 feet in depth, from the rim to the top of the bench, unless otherwise specified within the Contract Documents.

6. Flexible Plastic Joint Sealing Compound

All joints in the manhole barrel, cone and/or flat top sections including the joint between the cast-in-place base and the bottom barrel section, shall be sealed with an approved preformed, flexible plastic gasket conforming to the following requirements:

- a. The flexible plastic gasket shall be in conformance with ASTM C-990-91, AASHTO M198-B, and ASTM C-990, latest versions.
- b. The plastic sealing compound shall be packaged in extruded pre-formed rope-like shapes of proper size to completely fill the joint when completely compressed, as per the pipe manufacturer's recommendations. The material shall be protected by a suitable, removable two-piece wrapper that may be removed as the compound is applied to the joint surface without disturbing the other wrapper, which remains attached to the compound for protection. The sealing compound shall be impermeable to water, have high immediate bonding strength to the concrete surface and shall maintain permanent plasticity, as well as resistance to water, acids, and alkalis inherent in sewer systems.
- c. All lifting holes shall be permanently and properly sealed with the plastic sealing compound or an approved concrete grout.

7. Adjustment

Grade rings shall be used to adjust and set final rim elevations, brick is not allowed. A 3-inch cast iron riser shall be used in conjunction with grade rings on all construction within streets. Cast iron shall conform to ASTM C62, Grade SW [AASHTO M114].

8. Mortar and Grout

Mortar and grout used in the shaping of inverts, grade ring gaps, setting and anchoring cast iron street fabrications, etc., shall consist of one part Type II Portland Cement and two parts of fine, clean sand. Only sufficient water shall be added to provide a stiff, workable cement mixture for proper troweling. Hydrate lime or masonry cement shall

not be used. Where relatively thin portions of grout are to be applied to the flow channel, top of bench, etc., and approved epoxy bonding coat shall be applied to the exposed concrete surfaces prior to grouting.

11.0.2.3 Bases and Inverts

Except as otherwise shown on the drawings, manhole bases shall be constructed of cast-in-place or precast concrete, as shown in the Wastewater Management Division Standard Detail Drawings, and as otherwise described in these Standard Construction Specifications. Inverts may be cast separately, but shall be constructed of cast-in-place concrete. All concrete used for these applications shall meet the requirements set forth in section 11.0.2.2 of these Standard Construction Specifications.

1. Sanitary Sewer Manholes

Sanitary Sewer manholes are normally designed and constructed such that inverts of the influent and effluent sewers are at the same relative elevation with sufficient drop to compensate for pressure head losses occurring in the manhole. Therefore except for special cases, the bench around the flow channel shall be constructed to the outside top of the largest pipe in the manhole. The top of the bench shall be poured with a slope towards the flow channel with an overall cross slope not exceeding ½ inch. Flow channels shall have smooth, rounded inverts shaped to match the lower half of the pipe. Proper shaping shall be accomplished by forming or shaping with a proper cement grout mixture. Changes in direction of flow through the manhole shall be made with a smooth continuously-curved channel utilizing the maximum radius possible. Changes in the size of channels, multiple flow channels, or changes in invert slopes, shall be made gradually and evenly, and shall be formed directly in the concrete.

- a. Outside Drops. Whenever specified on the Drawings, directed by the Construction Project Manager, or where the elevation difference between the incoming sewer inverts and the outgoing invert is 18 inches or greater, an outside drop shall be constructed. The diameter of the drop shall not be less than the diameter of the incoming sewer pipe to be dropped. A concrete encasement will be required around the drop pipe as shown and detailed within the Wastewater Management Division Standard Details, S-530.

Quantities and costs for the outside drop configuration shall be measured and paid for separately from the manhole unless otherwise specified.

2. Storm Sewer Manholes

Flow channels in storm sewer manholes shall be as shown in the Wastewater Management Division Standard Detail Drawings for the particular type of manhole base utilized. Except for special situations, and where specifically noted, outside manhole drops will not be required. All exposed channel edges and cut pipe edges shall be grouted smooth. The minimum thickness of the cast-in-place concrete at any point shall not be less than 6-inches. The construction of the manhole base and shaping of inverts, including all pipes within the dimensions of the manhole, will be considered to be incidental to the construction of the manhole and all costs shall be included in the unit price bid for the manhole structure.

11.0.2.4 Stub-Outs and Block-Outs

Block-outs are the preferred method of construction for future connections. These shall be constructed as specified within the Contract Documents.

Where stub-outs are specifically indicated on the drawings and where a specified pipe size for future connections is to be constructed, the pipe used for stubbing shall extend a nominal 2 feet beyond the outside of the manhole barrel, unless otherwise noted, and shall terminate with a bell end [or spigot end if applicable]. The pipe end shall be sealed with an approved, pre-fabricated plug or cap conforming to the joint detail of the pipe supplied. For pipe greater than or equal to 30-inches in diameter, a full section of pipe shall be installed as the manhole stub. Shop drawings shall be submitted for approval.

The use of brick or concrete fill as a means of plugging will only be permitted on sewers that are to be abandoned. Unless otherwise stated in the contract documents, stub-outs and plugs or caps will be considered to be incidental to the construction of the associated manholes, and all costs incurred shall be included in the unit price bid for the manhole structure.

11.0.2.5 Flexible Booted Connections

Flexible watertight rubber boots for the jointing of any sewer pipe to any precast manhole base, barrel section, inlet box, or vault shall conform to the Specifications contained herein and to the Wastewater Management Division Standard Detail Drawings. Flexible connectors shall meet the requirements of ASTM C923.

11.0.3 Structures

11.0.3.1 Concrete

All structural concrete shall be CDOT Class D, with the revisions noted within this section.

11.0.3.2 Reinforcement

All structures shall be reinforced as shown on the Drawings or within the Wastewater Management Division Standard Details. All reinforcing steel shall be ASTM A-615, Grade 60 with deformed bars.

11.0.4 Concrete Flatwork

11.0.4.1 Concrete

All flatwork shall be CDOT Class D, unless otherwise approved by the Project Engineer.

11.0.4.2 Reinforcement

All required reinforcement shall be in accordance with the Contract Documents.

11.0.5 Storm Inlets

The work under this subsection shall consist of furnishing all materials and constructing concrete catch basins, including excavation, concrete removal and backfill. Work shall be done at the locations designated on the project plans and in accordance with the Wastewater Management Division Standard Detail Drawings and other requirements of the Contract Documents. All inlet structures and related components shall be designed for AASHTO HS20 loading conditions.

11.0.5.1 Concrete

Concrete shall be Class D, with a minimum 28-day strength of 4500 psi. Cement used in concrete shall conform to ASTM Designation C-150 Type II cement. All concrete used for these applications shall meet the requirements set forth within these Standard Construction Specifications.

11.0.5.2 Masonry Mortar

Masonry mortar (grout) shall be composed by volume of one part Portland cement, two parts fine aggregate, one fifth part hydrated lime and sufficient water to provide a plastic mixture. Mortar in concrete fill shall obtain a 28 day strength of 2000 psi.

11.0.5.3 Reinforcement

All inlets shall be reinforced as shown on the Drawings or Wastewater Management Division Standard Details. All reinforcing steel shall be ASTM A-615, Grade 60 with deformed bars. The diameter of bend measured on the inside of the bar shall be 6 bar diameters. All reinforcing steel shall be 2" clear minimum from formed surfaces and 3" clear against earth unless otherwise noted. Splicing of reinforcing steel shall be permitted only where detailed on the Drawings.

11.0.5.4 Connectors

Connectors for single inlets shall be 15" diameter (min.) with desired slope of 1 percent, for double inlets connectors shall be 18" diameter with desired slope of 1.8 percent and for triple inlets connectors shall be 21" with a desired slope of 1.8 percent. All connections to main line storm sewers shall be cored and collared in accordance with the Wastewater Management Division Standard Detail Drawings. Saw cutting and/or jack hammering will not be permitted.

11.0.5.5 Castings (No. 16 Inlets)

Frame shall be Denver Standard Pattern and grate where required shall be No. 16 Grate (Wastewater Management Division Standard Detail-S-716). All castings shall conform to ASTM A-48 (Class 35b) with a minimum tensile strength of 35 ksi. Castings shall not be dipped or painted prior to field inspection; once castings are approved by the Division for project usage, they shall be coated with an approved material. All castings shall be heavy duty and capable of withstanding AASHTO H-20 loadings. Horizontal bearing surfaces of all frames and grates shall be machined to eliminate any rocking action or non-uniform bearing.

11.0.5.6 Steps

Manhole steps shall be required for all new inlets greater than 4' in depth, unless otherwise specified within the Contract Documents. Single Type 16 inlets are exempt from this requirement.

11.0.5.7 Construction Requirements

All storm inlets shall be constructed of cast-in-place concrete, unless specifically approved for precast construction by the City.

1. Bedding and Backfill

All catch basins/inlets shall be cast in place. Subgrade shall be Class B Bedding compacted to 90% maximum dry density (AASHTO designation T-180). Backfill shall be hand tamped in 6" lifts, Backfill Method B.

2. Inlet Depths

Desired depths for single inlets shall be 3.5 feet (flow line to floor), for double inlets depth shall be 4 feet and for triple inlets depth shall be 4.5 feet. Inlets are designed to allow for 6 foot depth maximum; for depths greater than 6 feet, shop drawings and design analysis shall be submitted for approval by the Construction Project Manager.

3. Forming

Inlets shall be formed both inside and out; casting of sidewalls against earth walls or other structures is not permitted. No formwork shall remain inside structure when complete.

11.0.6 Backfill Requirements

The following outlines backfill requirements around manholes, structures, inlets, utilities and appurtenances. Structures shall include but not be limited to: type B manholes, type P manholes, box culvert and special structures noted within the Contract Documents. All structures shall be constructed in accordance with the most recent addition of the Wastewater Management Division Standard Detail drawings, and/or in conjunction with special details provided within the Contract Documents.

Method B backfilling, as described within these Standard Construction Specifications, is required around manholes, structures, inlets, utilities and appurtenances, unless otherwise specified or directed by the Construction Project Manager. The following backfilling constraints and requirements shall apply for all such facilities:

1. Cast-in-place: Inlets ($\leq 6'$ deep), Manhole Bases and Structure Bases

May be backfilled and compacted around, once the concrete has achieved 80% of the required 28-day compressive strength indicated in the Contract Documents.

For inlet depths larger than six (6) feet, from top of base slab to the top of wall at flow line of the lip, shop drawings and a design analysis must be submitted to the Construction Project Manager for approval. These submittals shall address the backfilling constraints during and after inlet placement.

2. Cast-in-place: Structure Walls

Shall not be backfilled or compacted against until the deck (top) slab has been placed, the walls have attained 80% of the required 28-day compressive strength, and the deck (top) slab has attained 80% of its required 28-day compressive strength as indicated in the Contract Documents.

3. Cast-in-place: Structure Decks or Top Slabs

May only be backfilled and compacted over once the concrete has attained the required 28-day compressive strength indicated in the Contract Documents.

4. Precast: Structures, Manhole Bases, Barrels, Cone Sections and Inlets

All precast components may be backfilled and compacted against, if manufactured a minimum of 28-days prior to placement, or if concrete test results demonstrate that the required 28-day compressive strength indicated in the Contract Documents has been achieved.

Precast barrels and cone sections may only be placed on cast-in-place manhole bases after 80% of the required 28 day compressive strength indicated in the Contract Documents has been attained.

Alterations and special allowances to these criteria may be granted at the discretion of the Construction Project Manager on a case by case basis.

End of Specification



CITY AND COUNTY OF DENVER
ENGINEERING DIVISION

Wastewater Capital Projects Management Standard Construction Specification

12.0 Riprap, Boulders and Slope/Channel Protection

12.1 General

This work consists of furnishing all labor, equipment and materials necessary to place riprap, soil riprap, grouted riprap, and erosion resistant materials where detailed on the Plans or as directed by the Construction Project Manager. The work includes water control, excavation and backfill, grading, sub-grade preparation, materials and installation of bedding, rock, riprap, boulders and grout as indicated herein and in the Contract Documents.

12.2 Submittals and Testing

In accordance with the Special Conditions submit documentation indicating source of stone and certifying materials for all types of rock will meet the requirements of this section. Include test results for specific gravity, abrasion, gradation and freeze thaw on samples of rock to be supplied on this project. Submit design mix for grout. In advance of delivery of rock to the work site an inspection of the quarry shall be arranged by the Contractor and shall include the Contractor, Construction Project Manager, and Quarry Representative. The quarry will identify the rock source and procedures that will be used to stockpile, mix and grade the types of riprap and boulders specified. The Construction Project Manager, following receipt and review of current gradation test results, may waive the requirement for field gradation tests at his discretion. If gradation tests are determined to be necessary by the Construction Project Manager, the following procedures shall be used.

For each type of riprap specified a random sample will be selected by the Construction Project Manager. The objective is to obtain a sample as it would be handled for normal delivery to the work site. It will then be placed in an approved area at the quarry and sized and sorted to identify and weigh the individual pieces as directed by the Construction Project Manager. The Contractor and Quarry Representative shall apply all labor and equipment to sort and weigh the riprap. Submit weight data of individual pieces and summary gradation curve. The approved sample shall then be hauled to the work site and stockpiled for comparison of future riprap deliveries. If the riprap being delivered appears to be outside of the specified gradation, or does not resemble the same stockpiles, the Contractor shall make appropriate adjustments at the quarry to ensure riprap meets the requirement of the Specification.

Boulders shall be visually checked by the Contractor at the quarry or work site as required for size, elongation, cracks, deterioration and other defects visible on the entire surface of the stone. If cracks are observed, the Contractor shall notify the Construction Project Manager to

re-inspect and retest the rock. Stone with cracks or defects that are detrimental to a long lasting product shall not be shipped to the work site.

12.3 Riprap and Boulders

Only quarry rock that is sound and durable against disintegration under conditions to be met in handling and placing, and is hard and tenacious and otherwise of suitable quality to ensure permanency in the specified kind of work, shall be used.

All rock shall be angular, each piece having its greatest dimensions greater than 3 times its least dimensions and shall conform to the following requirements and testing standards:

1. The riprap designation and total thickness of riprap shall be as shown in the contract documents. The maximum stone size shall not be larger than the thickness of the riprap.
2. The specific gravity of the riprap shall be two and one-half (2.5) or greater.
3. Neither width nor thickness of a single stone of riprap shall be less than one-third ($\frac{1}{3}$) of its length.
4. Broken concrete or asphalt pavement shall not be acceptable for use in any portion of the Project.
5. Rounded riprap (river rock) is not acceptable unless specifically designated in the Contract Documents.
6. The color of the riprap shall be gray with gray/blue hues or other acceptable colors approved by Construction Project Manager prior to delivery to the Project site. Color shall be consistent on the entire Project and shall match the color of rock to be used for all other portions of the Project Scope.
7. Minimum density for acceptable riprap shall be one hundred sixty five (165) pounds per cubic foot. The specific gravity shall be according to the bulk-saturated, surface-dry basis, AASHTO T85.
8. The riprap shall have a percentage loss of not more than forty percent (40%) after five hundred (500) revolutions when tested in the Los Angeles machine in accordance with AASHTO Test T96.
9. The riprap shall have a percentage loss of not more than ten percent (10%) after five (5) cycles when tested in accordance with AASHTO Test T104 for ledge rock using sodium sulfate.
10. The riprap shall have a percentage loss of not more than ten percent (10%) after twelve (12) cycles of freezing and thawing when tested in accordance with AASHTO Test T103 for ledge rock, procedure A.
11. Rock shall be free of calcite intrusions.
12. Each load of riprap shall be reasonably well graded from the smallest to the largest size specified. Stones smaller than the two-to-ten percent (2-10%) size will not be permitted in an amount exceeding ten percent (10%) by weight of each load. Control

of gradation shall be by visual inspection. However in the event Construction Project Manager determines the riprap to be unacceptable, the Construction Project Manager shall pick two (2) random truckloads to be dumped and checked for gradation. Mechanical equipment and labor needed to assist in checking gradation shall be provided by Contractor at no additional cost.

12.3.1 Types, Sizes and Classifications

The types, size, or classification of riprap to be placed will be noted on the Plans. Unless otherwise specified in the Plans or the Contract Documents riprap placed in accordance with the requirements for "dumped riprap" will be considered satisfactory. All riprap shall be placed on a prepared slope on a prepared filter media consisting of either a heavy duty plastic filter cloth or a free draining granular bedding media as described in the materials section of this specification. If the existing soils conditions meet the requirements for filter media the filter media will not be required.

Riprap used shall be the type designated within the contract documents and shall conform to **the table on the following page:**

Riprap Designation	% Smaller Than Given Size By Weight	Intermediate Rock Dimension (inches)	d ₅₀ * (inches)
Type VL	70 - 100	12	6
	50 - 70	9	
	35 - 50	6	
	2 - 10	2	
Type L	70 - 100	15	9
	50 - 70	12	
	35 - 50	9	
	2 - 10	3	
Type M	70 - 100	21	12
	50 - 70	18	
	35 - 50	12	
	2 - 10	4	
Type H	70 - 100	30	18
	50 - 70	24	
	35 - 50	18	
	2 - 10	6	
Type VH	70 - 100	41	24
	50 - 70	33	
	35 - 50	24	
	2 - 10	9	

* d₅₀ = Mean Particle Size

12.3.1.1 Dumped Riprap

This type of riprap shall consist of angular or fractured rock dumped in place on a prepared slope and filter media to form a well graded mass with a minimum of voids. Asphalt, broken concrete and other materials not classified as rock will not be allowed for use as riprap.

12.3.1.2 Soil Riprap

The soil material shall be native or topsoil and mixed with sixty five percent (65%) riprap and thirty five percent (35%) soil by volume. Soil riprap shall consist of a uniform mixture of soil and riprap without voids. Bedding material is not required for soil riprap. This type of riprap shall consist of angular or fractured rock mixed with 35% soil by volume dumped in place on a prepared slope to form a uniform mixture of soil and riprap without voids per Section 12.2.1C.

12.3.1.3 Grouted Riprap

This type of riprap shall consist of rock with all parts of the interstices filled with Portland cement mortar. The finished product shall be aesthetically pleasing resembling hand placed stone or fireplace rockwork. Colored concrete grout may be specified as defined elsewhere within these Standard Construction Specifications.

12.3.1.4 Feature Boulders

Feature Boulders shall consist of the same material as riprap, differing only by size. Feature Boulders shall have a minimum dimension of four (4) feet, or as shown on the Plans.

12.3.1.5 Boulders

Boulders shall consist of the same material as riprap, differing only by size. Boulders shall have a minimum dimension of two (2) feet, or as shown on the Plans.

12.3.2 Bedding

The granular bedding designation and total thickness of bedding shall be as shown in the Contract Documents. Granular bedding shall meet the same requirements for specific gravity, absorption, abrasion, sodium sulfate soundness, and freeze-thaw durability as required for riprap and as follows:

1. Broken concrete asphalt pavement or sledge, shall not be acceptable for use in any project. Rounded river rock is not acceptable unless specifically designated in the Contract Documents.
2. Shall conform to the quality requirements of AASHTO M197.
3. The requirements for the wear test in AASHTO T96 shall not apply.

4. Gradation for Granular Bedding:

U.S. Standard	Percent by Weight Passing	Square Mesh Sieves
<u>Sieve Size</u>	<u>Type I</u>	<u>Type II</u>
3 inch		90 - 100
1-½ inch		
¾ inch		20 - 90
⅜ inch	100	
No. 4	95 - 100	0 - 20
No. 16	45 - 80	
No. 50	10 - 30	
No. 100	2 - 10	
No. 200	0 - 2	0 - 3

12.4 Excavation

The excavations shall be finished to smooth and uniform surfaces conforming to the line and grade specified. Variation from the finished grade elevations specified shall not be more than 1.0 inch. Materials shall not be wasted without written permission of the Construction Project Manager. Excavation operations shall be conducted so material outside of the slope limits will not be disturbed. Prior to beginning grading operations, all necessary clearing and grubbing in that area shall have been performed. The top six (6) inches of material from all areas to be excavated shall be designated as topsoil and shall be removed and stockpiled in the designated location on the plans. Following removal of topsoil, in the designated excavation areas, the remaining material shall be removed and stockpiled separately for use as sub-grade material in the designated location on the plans. Unclassified excavation shall consist of the excavation of all materials of whatever character required for the work, obtained within the project limits, including surface boulders, masonry, organics, muck, and slag that are not removed under some other item. The work will also include hauling of unsuitable unclassified excavation materials off the site.

12.4.1 Unclassified Excavation

All excavation from six (6) inches below existing grade to the top of sub-grade for the associated boulders and/or riprap shall be designated as Unclassified Excavation.

Unless otherwise stipulated in the Contract Documents, no separate payment will be made for unclassified excavation and all costs incurred will be considered to be included within the unit price bid for the associated work.

12.4.2 Overexcavation

In locations where soil with unsuitable bearing characteristics are encountered, the Construction Project Manager may order that the unsuitable material be removed and be replaced with granular and/or rock backfill material to provide suitable bearing for the structure. At least eight (8) inches of acceptable material must be present below the proposed riprap, soil riprap, grouted riprap or boulders within two (2) feet of existing grade.

The overexcavation will be paid for in accordance with the bid items included within the Contract Documents, regardless of soil classification. No measurement for payment will be made of any material removed or necessary to fill overexcavated areas: outside of the limits for structure excavation, outside of limits defined within the Contract Documents, beyond the limits required for structure excavation performed for the Contractor's convenience or, where excavations for footings, slabs, etc., are made below the required elevations without specific authorization from the Construction Project Manager. In these situations, excess excavation and backfill shall be at the Contractor's expense and the areas shall be filled in a manner satisfactory to the Construction Project Manager.

12.4.3 Removal of Water

During construction, the Contractor shall provide and maintain adequate equipment to properly remove and dispose of all water entering the work area. In water bearing strata, well points, sub drains or any other method approved by the Construction Project Manager may be required to provide a dry trench.

The discharge from any dewatering operations shall be conducted to natural drainage channels or other structures as approved by the Construction Project Manager and in accordance with applicable permits. Ground water shall not be discharged into sanitary sewers.

Excavation work areas shall be kept free from water during excavation, fine grading, pipe laying and grouting. Dewatering, sufficient to provide a completely dry work area, shall be maintained during all excavation, construction and grouting operations. The Contractor shall be responsible for damage of any nature resulting from the dewatering operations.

Unless provided for in the Contract Documents, dewatering shall be considered as incidental to construction and all costs incurred will be considered to be included in the unit price bid for the construction of each section of sewer line, associated structures, laterals and appurtenances.

12.5 Backfill

Backfill around riprap or boulder structures shall be performed in accordance with these Standard Construction Specifications. Backfill shall be placed only after walls or other constructed items have been inspected and the approval of the Construction Project Manager to commence backfilling has been obtained. Backfilling against riprap or boulder structures is allowed only after the concrete has properly cured for not less than seven days, or until other testing procedures (concrete test cylinders) indicate that the concrete has attained sufficient strength so as not to be damaged by the backfilling operation.

12.6 Topsoil

Top soil material shall be taken from the topsoil stockpile and placed to a minimum depth of six (6) inches to the limits shown on the plans. Additional topsoil material, if necessary, shall be obtained from the sub-grade stockpile as approved by the Construction Project Manager. The topsoil shall be placed uniformly and compacted to a minimum of 85% Standard Proctor density ASHTO T-99. The intent is to provide a suitable medium for revegetation activities.

12.7 Unsuitable Materials

Materials encountered during construction that are deemed by the Construction Project Manager to be unsatisfactory as structure sub-grade shall be removed to a maximum depth as approved by the Construction Project Manager, and replaced with stabilization material including, rock, or other materials approved by the Construction Project Manager. The source of stabilization material shall be approved by the Construction Project Manager prior to placement. Excavated muck shall be removed and hauled off the site.

12.8 Construction Requirements

Channel slopes, bottoms, or other areas that are to be protected with riprap, soil riprap, or boulders shall be free of brush, trees, stumps, and other objectionable material and be graded to a smooth compacted surface. Contractor shall excavate areas to receive riprap or boulders to the sub-grade for granular bedding or for soil riprap to the specified depth (bedding material is not required for soil riprap). The sub-grade materials shall be stable. If unsuitable materials are encountered, they shall be removed and replaced in accordance with these Standard Construction Specifications for sub-grade that has been excavated in undisturbed soil. Additional compaction shall not be required unless specified by Construction Project Manager. When sub-grade is built up with embankment material it shall be compacted to ninety five percent (95%) optimum density (ASTM D698). After an acceptable sub-grade is established, the soil riprap or bedding shall be immediately placed and leveled to the specified elevation. Immediately following the placement of the bedding material, the riprap shall be placed. If bedding material is disturbed for any reason, it shall be replaced and graded at Contractor's expense. In-place bedding materials shall not be contaminated with soils, debris or vegetation before the riprap is placed. If contaminated, the bedding material shall be removed and replaced at Contractor's expense.

12.8.1 Placement

For the purposes of the following, boulders, riprap and rock are used interchangeably.

When riprap is placed on slopes, placement shall commence at the bottom of the slopes working up the slope. Place the riprap in a stepped fashion with the bottom of the uphill riprap below the top of the downhill riprap by one half ($\frac{1}{2}$) of the height of the riprap minimum.

The entire mass of riprap shall be placed on either channel slopes or bottoms so as to be in conformance with the required gradation mixtures and to lines, grades, and thickness shown on the plan set. Riprap shall be placed to its full course thickness at one operation and in such a manner as to avoid displacing the underlying bedding material. Placing of riprap in layers, or by dumping into chutes, or by similar methods shall not be permitted.

All material going into riprap protection for channel slopes or bottoms shall be so placed and distributed that there shall be no large accumulations of either the larger or smaller sizes of stone. Some hand placement may be required to achieve this distribution.

It is the intent of these Standard Construction Specifications to produce a fairly compact riprap protection in which all sizes of material are placed in their proper proportions. Unless otherwise authorized by Construction Project Manager, the riprap protection shall be placed in conjunction with the construction of embankments or channel bottoms with only sufficient delay in construction of the riprap protection, as may be necessary, to allow for proper construction of the portion of the embankment and channel bottom which is to be protected. Contractor shall maintain the riprap protection until accepted. Any material displaced for any reason shall be replaced to the lines and grades shown in the Contract Documents at no additional cost to City and County of Denver. If the bedding materials are removed or disturbed, such material shall be replaced prior to replacing the displaced riprap.

The basic procedure shall result in larger materials flush to the top surface with faces and shapes arranged to minimize voids, and smaller material below and between larger materials. Surface grades shall be a plane or as indicated, but projections above or depressions under the finished design grade more than ten percent (10%) of the rock layer thickness shall not be allowed. Smaller rock shall be securely locked between the larger stone. It is essential that the material between the larger stones not be loose or easily displaced by flow or by vandalism. The stone shall be consolidated by the bucket of the backhoe or other means that will cause interlocking of the material. All rock is to be placed in a dewatered condition beginning at the toe of the slope or other lowest point.

Riprap shall be rejected, which is either delivered to the job site or placed, that does not conform to this section. Rejected riprap shall be removed from the Project site by the Contractor at his/her expense.

Following acceptable placement of granular bedding, riprap placement shall commence using one of the following methods:

Machine Placed Riprap

Riprap shall be placed using appropriate construction equipment on the prepared slope or channel bottom areas in a manner which will produce a reasonably well-graded mass of stone with the minimum practicable percentage of voids. Riprap shall be machine placed, unless otherwise stipulated in the Contract Documents.

Hand Placed Riprap

Hand placed riprap shall be performed during machine placement of riprap and shall conform to all the requirements outlined above. Hand placed riprap shall also be required when the depth of riprap is less than two (2) times the nominal stone size, or when required by the Contract Documents.

After the riprap has been placed, hand placing or rearranging of individual stones by mechanical equipment shall be required to the extent necessary to secure a flat uniform surface and the specified depth of riprap, to the lines and grades as shown in the Contract Documents.

12.8.1.1 Types

Buried Riprap

Where riprap is designated to be buried, place onsite excavated material that is free from trash and organic matter in riprap voids by washing and rodding. Prevent excessive washing of material into stream. When voids are filled and the surface accepted by the Construction Project Manager, place a nominal six (6) inches of soil over the area, or as designated in the Contract Documents. Fine grade, seed, and mulch per the Contract Documents.

Soil Riprap

Adjacent stockpiles of riprap and soil shall be created and mixing done at the stockpile location, not at the location where soil riprap is to be placed. Mix thirty five percent (35%) soil by volume with stockpiled riprap, using additional moisture and control procedures that assure a homogenous mixture, where the soil fills the inherent voids in the riprap without displacing riprap.

Place a first layer of smaller soil riprap of approximate d_{50} thickness. Then place the top layer with surface rocks that are largely d_{50} or greater, filling voids as necessary with smaller planted riprap. Create a smooth plane as described in Paragraph A. The mixture shall be consolidated by large vibratory equipment or backhoe bucket to create a tight, dense interlocking mass. The soil shall be further wetted to encourage void filling with soil. Any large voids shall be filled with rock and small voids filled with soil. Excessively thick zones of soil prone to washing away shall not be created (e.g., no thicknesses greater than six (6) inches). For buried soil riprap, the top surface shall be covered with four (4) inches of topsoil such that no rock points are protruding. The final surface shall be thoroughly wetted for good compaction, smoothed and compacted by vibrating equipment; the surface shall then be hand raked to receive planting or seeding. With prior approval of Construction Project Manager, layering the riprap and soil instead of premixing may be allowed if the native soil is granular.

Feature Boulders

Feature Boulders serve an aesthetic function and as such shall be placed and rotated into final position as directed by the Construction Project Manager in order to achieve the desired result.

Grouted Boulders

Grouted riprap and boulder lined channel edge shall be placed at the locations as shown in the Construction Documents and installed with the following requirements:

1. The sub-grade to receive each boulder shall be excavated and any unstable material shall be removed. Approved material shall be placed and compacted in a maximum of four-inch (4") lifts to ninety five percent (95%) of Maximum Standard Proctor Density (ASTM D698) to re-establish the sub-grade of each boulder. Unstable material shall be removed from the Project site and disposed of by Contractor. Removal and replacement of unstable material shall only be completed at the direction of Construction Project Manager and shall be paid for under Muck Excavation. Backfill behind boulders shall be compacted to ninety five percent (95%) Maximum Standard Proctor Density (ASTM D698).

Care shall be taken during compaction to avoid disturbing and/or damaging the integrity of the boulder channel edge.

The top of all boulders shall be as indicated in the Construction Documents. Finished grades and sub-grades for boulders will be determined from the height of each boulder used.

2. The boulders shall be carefully picked and arranged so that adjacent rock surfaces match within two (2) inches in top elevation and two (2) inches along the vertical exposed face or channel side of rock. Boulders shall be placed such that adjacent boulders "touch" each other and voids do not exceed four (4) inches. It is the intent of construction to minimize voids and grout placed between boulders.
3. Smaller rocks shall be "chinked in" to fill all voids behind the boulders. Placement shall be approved by Construction Project Manager prior to grouting.
4. Prior to placing the grout, any type of debris, fines, smaller rock, or silt shall be removed from around or under the boulders.
5. Dewatering shall be implemented to guarantee that the grout will not be placed in water and for a period of twenty four (24) hours after the grout has been placed.
6. Keep boulders receiving grout wet at all times prior to receiving grout. The concrete grout shall be placed by injection methods by pumping under low pressure, through a two-inch (2") maximum diameter hose to ensure complete penetration of the grout into the void area as detailed in the Contract Documents. Grout will be placed up to eight (8) inches from the top of boulders, or as directed by the Construction Project Manager. The Operator shall be able to stop the flow and will place grout in the voids and not on the surface of the rocks.
7. Grout shall be troweled out and finished to minimize visibility. Clean and wash any spillage before the grout sets. The visual surfaces of boulders will be free of grout to provide a clean, natural appearance. If washing does not clean off grout residue, Contractor shall wash off any grout residue with muriatic acid and water, using a brush to scrub off the residue. A "pencil" vibrator shall be used to make sure all voids are filled between the boulders. The intent is to fill all voids from the sub-grade level around the boulders to a depth as shown in the Contract Documents. The "pencil" vibrator may be used to smooth the appearance of the surface, but Contractor shall use a wood float to smooth and grade the grout around the boulders. The grout mix shall be stiffened and other measures taken to retain the grout between the boulders.
8. Contractor shall, if deemed necessary, support the boulders from falling over before and during the placement of rock, grout, backfill, and compaction work on either side of the boulder.
9. Grout shall receive cold weather protection and curing in accordance with the most recent version of CDOT Standard Specifications for Road and Bridge Construction (section 601.13) as applicable.

12.9 Grouted Rock Retaining Walls

Grouted rock retaining walls shall be placed at locations as shown in the Contract Documents and installed with the following requirements:

1. The grouted rock walls shall be constructed to the dimensions in the locations shown in the Contract Documents. The walls shall be constructed with a one (1) horizontal to four (4) vertical batter on the front and back face, with a minimum width of one (1) foot at the top of the wall.
2. The stone of the wall shall be laid to form substantial masonry, presenting a neat, finished appearance. Headers shall hold the heart of the wall to the face. Headers shall occupy at least twenty percent (20%) of the area and they shall be evenly distributed. The length of stretchers shall not exceed three (3) times their rise. Face stones shall be laid to break joint. Rock shall be hand graded so that only the larger stones are used in the face. Face stones shall be laid to break joint so that each rock laid rests on two beneath it. Spalls and pinners will not be allowed in the face and shall be used in the backing only where necessary.
3. All face stones shall be pitched to a string line on straight walls or laid to batter stakes for curved walls. The batter shall be consistent with respect to all parts of the wall and shall meet the minimum requirements set forth in the detail. The degree of roughness on the exposed face shall be measured with a six-foot (6') straightedge supported between adjacent projections and stone face. Variations in excess of 3 inches, measured from the straight edge to the extreme depression in the stone, will not be permitted. Rear faces shall present approximately plane surfaces and shall in general conform to the detail.
4. Grout shall be placed to fill all voids between the rocks throughout the walls. Any "loose" rocks shall be re-grouted by machine or hand methods. Grout shall be recessed approximately two (2) inches from the face of the wall in order to give a "dry stacked" appearance.
5. Prior to placing the grout, any type of debris, fines, smaller rock, or silt shall be removed from around the rocks.

Dewatering shall be implemented to guarantee that the grout will not be placed in water and the area will remain dewatered for a period of ten (10) hours after the grout has been placed.

The surface of the rocks receiving grout shall be wet at all times prior to receiving grout.

6. Clean and wash any spillage before the grout sets on the outside face and top of walls. The visual surfaces of the rocks will be free of grout to provide a clean natural appearance. If washing does not clean off grout residue, then Contractor shall wash off any grout residue with muriatic acid and water, using a brush to scrub off the residue.
7. Grout shall receive cold weather protection and curing in accordance with the CDOT Standard Specifications for Road and Bridge Construction (section 601.13) as applicable.

End of Specification



CITY AND COUNTY OF DENVER
ENGINEERING DIVISION

Wastewater Capital Projects Management Standard Construction Specification

13.0 Fencing

13.1 Description

This item shall consist of furnishing and installing new fencing and/or removing and salvaging the existing fencing and restoring the same in conformance with the lines, grades and/or alignment shown on the Plans. Wherever the materials to be removed are not in good condition, as judged by the Construction Project Manager, or wherever the Contractor has damaged the materials during the process of removal, equal or better quality fencing materials than the existing will be furnished and installed by the Contractor. Relocated and/or new fencing will be chain link, heavy construction type. The fence heights shall be as noted on the Plans.

13.1.1 Chain Link Fence

Where specified on the plans or directed by the Construction Project Manager, chain link fencing shall be constructed as detailed on the drawings and as specified herein.

13.1.2 Security Fence

Where specified on the plans or directed by the Construction Project Manager, security fencing shall be constructed as detailed on the drawings and as specified herein. The fencing shall be topped with 3-strand barbed wire which will extend the overall height of the fence by one (1) foot.

13.1.3 Shop Drawings and Data

Complete detail drawings and specifications for the fence, gates and accessories shall be submitted in accordance with the procedure set forth in the Special Contract Conditions.

13.2.4 Removal of Existing Fencing

All ties and clamps shall be removed to free the fabric from posts, rails, braces, tension bars and the like. The fabric shall be removed and stored appropriately to be reused. All rails, braces, barbed wire, tension bars and the like shall be removed from posts to a sufficient degree that will allow the removal of the posts.

The post footings shall be excavated and the concrete shall be broken until the post is free. Posts higher than ten (10) feet may be cut in segments or left intact for relocation at the option of the Contractor and as approved by the Construction Project Manager.

13.3 Materials

Materials for all fencing shall conform to the standards of the existing fence or to the minimum standards as outlined herein. All new steel or malleable iron parts and accessories shall be hot dip galvanized after fabrication.

13.3.1 Posts

All posts shall be steel pipe, ASTM A120, standard weight, Schedule 40. Post diameters shall be as follows.

a. **Line Posts**

- (1) Up to ten (10) foot high fence inclusive, line posts shall be 2-1/2 inch O.D. pipe, 3.65 lbs. per ft.
- (2) Over ten (10) foot to eighteen (18) foot high fence inclusive, line posts shall be 3 inch O.D. pipe, 5.79 lbs. per ft.
- (3) Over eighteen (18) foot to thirty (30) foot high backstop fence inclusive, line posts shall be 4 inch O.D. pipe 9.1 lbs. per ft.

b. **Terminal End. Corner and Pull Posts**

- (1) Up to eighteen (18) foot high fence inclusive; terminal, end, corner and pull posts shall be 3 inch O.D. pipe, 5.79 lbs. pr ft.
- (2) Over eighteen (18) foot to thirty (30) foot high backstop fence inclusive; terminal, end, corner and pull posts shall be 4 inch O.D. pipe, 9.1 lbs. Per ft.

c. **Gate Posts.** Pipe, 9.1 lbs. per ft. and 4 inch O.D.

- (1) **Top Rail** shall be 1-5/8 inch O.D. pipe, 2.27 lbs.
- (2) **Post Tops** shall be pressed steel or malleable iron designed to prevent entry of moisture into tubular posts and/or for barbed wire installation.
- (3) **Stretcher Bars** shall be steel, 3/16 inch by 3/4 inch, or equivalent area.
- (4) **Fabric** shall be No.9 wire woven into a 2" mesh; galvanized AS~M A392, Class II.
- (5) **Fabric Ties** shall be No.7 aluminum wire or 12 gauge galvanized steel wire.
- (6) **Concrete Collars** around posts: f'c -2000 psi, 5 sack mix, with Type r or Type II cement conforming to ASTM C-150.

13.3.8 Gates

Materials for gates shall conform to the

- a. **Fabric** shall be the same as fence fabric.
- b. **Frames** shall be 2 inch O.D. pipe, 2.72 lbs. per ft.
- c. **Hinges** shall be heavy pattern with large bearing surfaces and shall not twist or turn under the action of the gate.
- d. **Latches** shall be forked type and shall be arranged for padlocking, with the padlock accessible from both sides of the gate.

- e. **Stops** shall consist of a roadway plate with anchor set in concrete and arranged to engage the plunger.

13.3.9 Security Fence

Materials for security fencing shall conform to the contract specific specifications and the following special items.

- a. **Barbed Wire Support Arms** shall be galvanized steel and shall extend at an angle of approximately 45°, and shall be fitted with clips or other means for attaching three strands of barbed wire. The top wire shall be approximately twelve inches horizontally from the fence line and the other wires spaced uniformly between the top of the fence fabric and the outside strand. The barbed wire support arm shall be of sufficient strength to withstand a weight of 200 lbs. applied at the outside strand of barbed wire.
- b. **Barbed Wire** shall consist of two strands of 12-1/2 gage steel wire with 14 gag; 4 point barbs spaced not more than 5 inches apart. All wire shall be zinc coated with a minimum coating of .80 ounces per square foot of surface area on 12-1/2 gage wire and .60 ounces per square foot of surface area on 14 gage wire.

13.4 Installation or Replacement of Fence

13.4.1 General Constructions

The Contractor shall perform such clearing and grubbing as may be necessary to construct or replace the fence to the required grade and alignment as shown on the Plans. Where specified on the plans or ordered by the Construction Project Manager, a one (1) foot wide concrete mowing strip shall be provided for the entire length of the fence. The fence shall be located along the center line of the mowing strip.

At locations where breaks in a run of fencing are required, appropriate adjustments in fence alignment and/or post spacing shall be made to satisfy requirements of conditions encountered.

13.4.2 Posts

Posts shall be held in proper position by secure bracing until such time as the concrete has set sufficiently to hold the posts. Materials shall not be installed on posts, or stress placed on guys nor bracing set in concrete until the concrete has developed enough strength to withstand the stress.

All line, terminal, corner and gate posts shall be of the size specified. Posts shall be of the proper length to accommodate full height of fabric as shown on the Plans and provide for footing to the depth required. All posts shall be set plumb and firmly in concrete footings with a maximum spacing of 10 feet between posts. Concrete footings shall be domed to shed water. All terminal, corner and gate posts shall be braced with horizontal braces and diagonal truss rods.

All posts shall have a post cap of heavy galvanized malleable iron or pressed steel.

The tops of all posts shall be set to the required grade and alignment.

13.4.3 Fabric

Fabric shall be firmly attached to the posts and braces. All wire shall be stretched taut and be installed to the required spacing. The completed fence shall be plumb and in straight alignment, firmly wired to prevent sag or looseness.

The fabric shall be the full height as shown on the Plans. Fabric shall be attached to the inside of posts with the wires or fabric clips, spaced at one (1) foot intervals on all posts and six (6) ties to each horizontal rail. Top and bottom selvages shall be knuckled for residential chain link fences and security fences.

13.4.4 Top Rails, Braces, Fittings, Ties, Tension Wire, Tension Bars

These items shall be the same lengths, dimensions and quantities as those of the existing fence or as shown on the Plans. The existing items shall be removed and replaced and where new items need to be purchased, the quality shall be equal to or better than the existing. The top rail shall extend through all line posts to form a continuous brace from end to end of each stretch of fence, be securely fastened at the end of each run, and have joints made with expansion sleeve couplings not less than 5 inches long.

13.4.5 Gates

Gates shall be constructed at or relocated to locations shown on the plans. Any materials not up to standard shall be replaced with materials of equal or better quality than the existing. Gates shall be installed to swing horizontally in true vertical plane and shall be provided with offset hinges to permit 180 degree swing.

Gates shall be installed so that they cannot be removed without disassembly of the hardware. Hardware attachment bolts shall be preened so that removal will be difficult.

Gates shall have all necessary latches, straps, locking bars and locking devices. Fabric shall be tightly stretched and securely fastened to gate frame with the proper number of bands, clips or tie wires and stretch bars shall be installed one (1) inch shorter than the full height of the fabric. Gates shall be free from sag or twist. Joints between frame members shall be made by welding or by means of heavy fittings and shall be rigid and water tight.

If welding is employed, it shall conform to the requirements of the American Welding Society. All welds shall be ground smooth. When the spelter coating has been burned by welding, the surface of the welded connection shall be thoroughly cleaned by wire brushing and all traces of the welding flux and loose or cracked spelter removed. The cleaned areas shall then be painted with two coats of zinc oxide-zinc dust paint conforming to the requirements of Federal Specification MIL-P-15145, latest revisions. The paint shall be properly compounded in a suitable vehicle in the ratio of one part zinc oxide to four parts zinc dust, by weight.

A method to padlock all gates shall be provided. Each padlock shall be provided with two keys.

End of Specification



CITY AND COUNTY OF DENVER
ENGINEERING DIVISION

Wastewater Capital Projects Management Standard Construction Specification

14.0 Removal and Disposal of Construction Debris and Contaminated Materials

14.0.1 General

The Contractor shall be required to transport all non-hazardous solid waste and construction debris to the Denver Arapahoe Disposal Site (DADS) landfill, in accordance with Executive Order 115. Only approved haul routes around DADS may be used (Contractor must contact landfill directly for these routes). Landfill fees, gate fees and applicable State surcharges will be paid for by the City and County of Denver, Wastewater Capital Projects Management. The Contractor is responsible for any special handling charges imposed by Waste Management at DADS.

All costs associated with loading, hauling, and disposal of construction debris and/or contaminated soils at DADS shall be considered included within the unit price bid for construction of each section of sewer, the associated structures, laterals and appurtenances unless provided for elsewhere in the Contract Documents. The City and County of Denver, Wastewater Capital Projects Management will not provide hauling tickets nor cover the fees associated with disposal of recyclable materials at the DADS landfill. Recyclable materials shall include: concrete, asphalt, clean soil, and any other materials generated onsite with a monetary value. No payment will be made for the loading, hauling and/or processing of recyclable materials.

If the waste material cannot be accepted at DADS, Conservation Services Inc. facilities are licensed to accept industrial waste. Facilities in Utah and Texas are licensed to accept hazardous waste. Landfill fees at these facilities will be paid for by the Contractor.

The work required for this section shall consist of exploratory investigation, testing, identification, removal and disposal of construction debris and contaminated materials associated with the construction of pipelines, box culverts, gulches, open channels, ponds and associated structures and appurtenances.

14.0.2 Contaminants

The contaminants required to be removed or treated may or may not be known at the time of award of the work. Contaminated soils may be encountered and have to be identified on the job site. Potentially and/or suspected contaminated sites of known and unknown origin may be listed at the end of the Contract Documents and are identified on the plans.

14.0.3 Environmental Consultant

The City and County of Denver, Wastewater Capital Projects Management will provide an Environmental Consultant to help identify, monitor and document and provide other assistance as required.

14.0.4 Contaminated Soil Identification

1. Remediation of soils with unknown contaminants will be performed by the Contractor as described herein or as directed by the Construction Project Manager with recommendations by the Environmental Consultant. Materials visibly contaminated or having field instrument (e.g. PID, FID, OVA, etc.) readings above established action levels will be excavated, or otherwise loaded for transport to an approved disposal facility or to a temporary storage area designated by the Construction Project Manager. Appropriate safeguards will be utilized to prevent or limit exposures to stored materials.
2. The stored material will be tested at the contractor's expense for contaminants. As dictated by the proposed disposal facility the parameters to be tested for will be based on the historical use of the area and the requirements of the facility used for disposal. The material will not be stored for more than 90 days.
3. Material identified as hazardous or non-hazardous will be disposed of in a manner consistent with current established federal, state and local regulations for waste material. A hazardous waste contractor shall be required for handling of hazardous material.
4. Materials with contaminants below action levels may be used for fill on-site or transported off-site. Materials with contaminants not specifically regulated will be disposed of as directed by the Construction Project Manager.
5. The owner of any contaminated material will be the City and County of Denver, for the purposes of permits and disposal only.

14.0.5 Submittals

The Contractor will submit the following information for approval prior to beginning work or as otherwise specified:

1. **Health and Safety Plan** meeting OSHA requirements of CFR 1910.120. The Health and Safety Plan for remediation work shall address the protection of health, safety and response to contingencies which could occur during remediation. It shall describe known and potential hazards related to remediation work activities. It shall include descriptions of construction and decontamination procedures for personnel and equipment. The plan will only be implemented if contaminated materials are encountered.

The contractor shall provide a project Health and Safety Officer. The project Health and Safety Officer shall be qualified by certification or training in the area of Industrial Hygiene or Hazardous Waste Health and Safety. The officer will have the authority and knowledge to design and implement a site-specific Health and Safety Plan and Hazardous Communication Program and to verify compliance with applicable safety and health requirements.

All persons working in and entering the areas designated by the Health and Safety Officer to be hazardous due to the presence or potential of contacting hazardous substances shall have previously received training according to the requirements in the Hazardous Waste Operation Regulations (OSHA 1910.120).

General site workers involved in construction activities in the designated areas shall receive 40 hours minimum training in the health and safety of hazardous waste; site workers and workers who are on-site occasionally to perform a single specified task shall receive 24 hours minimum of training. Personnel overseeing the health and safety of other workers shall receive an additional eight hours of supervisor training in that capacity. Documents certifying that the training requirements have been met and that all personnel are current on their refresher training shall be present at the project office or trailer or otherwise be made available to the project Health and Safety Officer and/or the Construction Project Manager.

In addition to the personnel working in the designated hazardous waste sites, all personnel working on this construction project shall be involved in the communication and understanding of potential hazards through a Hazardous Communication Program in accordance with the provisions of OSHA regulation 29 CFR 1910.12. This program shall include all elements of the regulations including training of personnel, compilation of Material Safety Data Sheets (MSDS), labeling, and placarding of hazardous chemicals, hazard identification of the construction area and monitoring of all activities to determine if new hazards are posed to the employees.

Reduced levels of training are to be identified for persons performing short duration or non-intrusive activities in areas in which the concentrations of or the potential for exposures to hazardous chemicals are reduced or shown to be minimal in the designated areas.

The training of employees in the non-designated areas are covered in the Hazard Communication Program for this phase of construction activities. This training shall include the following elements:

1. Methods of detecting hazardous chemicals.
2. Physical and health hazards of chemicals in the area.
3. Personal protective measures that are implemented to protect the employees.
4. Details of the Hazardous Communication Program such as emergency response procedures and location of the Material Safety Data Sheet.

2. Material Management Plan

A. *Sampling and Analysis Plan* (SAP) which describes methods of sampling, testing and analysis to obtain additional data on chemical constituents of the various materials. The Environmental Consultant will prepare this plan which shall be reviewed by all parties prior to the commencement of this aspect of construction. The purpose of the SAP will be to provide a basis for classifying a material as hazardous or non-hazardous and to provide confirmation and documentation of completed remediation work as it relates to project construction.

B. Product Data: Submit the following as part of a Pre-Construction Submittal Package.

1. Material list for items proposed to be provided under this section.
2. Certificates signed by the materials producer and the subcontractor stating that all material, meet or exceed the specified requirements.
3. **Materials Samples:** Submit adequate and representative samples of the backfill material to the Testing Laboratory for pre-construction tests.
4. **Test Reports:** Submit at least one week prior to beginning of the work of this section the test reports for the pre-construction testing performed by the Testing Laboratory.
5. **Disposal Profile Sampling:** If contaminated soil is known or believed to exist in the project alignment, the contractor shall be responsible for waste classification, profiling and manifesting. This shall be done in advance of the construction phase.

The material management plan is a dynamic document. It shall be the contractor's responsibility to coordinate revisions as necessary based upon changing site conditions.

14.0.6 Materials

14.0.6.1 Backfill Materials

Materials generated on-site or if imported shall be predominantly granular non-expansive soil free from roots and other unsuitable material meeting the requirements of Section 5.0 of these Standard Construction Specifications. The Contractor shall try to generate all backfill materials on-site. Imported fill materials will only be allowed in cases where sufficient quantities of suitable backfill material cannot be generated on-site.

14.0.6.2 Backfill of Excavated Areas

Excavated areas outside the vertical limits of construction will be backfilled and regraded using uncontaminated soils. Compaction requirements are described in Section 5.0. The fill materials will be from on-site stockpiles as described above. The surface will be regraded to match natural contours and drainage patterns and the areas to be reseeded or otherwise restored to match existing conditions prior to the contaminated material excavation.

14.0.7 Execution

14.0.7.1 Removal

1. Contaminated materials will be removed to a depth of 3 feet below construction within the horizontal limits of construction at the direction of the Construction Project Manager. If the contamination extends less than three (3) feet, a minimum thickness of three (3) inches of soils below the contaminated materials will be removed, loaded, transported, and disposed of.
2. Upon completion of initial contaminated material removal, the excavated area will be inspected by the Construction Project Manager and or the Environmental Consultant and additional materials will be removed as deemed necessary based on visual

observations, instrument readings, and the results of initial and confirmatory laboratory testing.

14.0.7.2 Disposal

The contaminated soils requiring disposal will be transported to a land fill approved to accept the waste. The landfill will be approved by the Construction Project Manager prior to transport and landfill fees will be paid for by the Contractor. A payment item is provided for this in the Bid Form and Submittal Package. The Denver Arapahoe Disposal Site (DADS) and the Conservation Services Inc. facilities are licensed to accept non-hazardous waste. Facilities in Utah and Texas are licensed to accept hazardous waste.

14.0.7.3 Confirmation Sampling

1. Upon completion of the contaminated material removal in each area, a confirmation soil sample will be collected by the Environmental Consultant in accordance with a Sampling and Analysis Plan (SAP) and the samples shipped to an approved testing laboratory for analysis.
2. The SAP will be prepared by the Environmental Consultant prior to construction and should contain methods of sampling and analysis to confirm if a material is hazardous or non-hazardous and that remediation work has been completed. The sampling will either be from a discrete location or composited, if appropriate. Duplicate and blank samples will be collected for laboratory quality assurance at the frequency described in the SAP. All samples will be labeled and sealed and appropriate chain-of-custody and shipping procedures followed.

14.0.7.4 Field Testing

1. The Testing Laboratory as designated by the Environmental Consultant, will perform tests and report results as approved by City of Denver Environmental Services (DES) and the City and County of Denver, Wastewater Capital Projects Management on soil samples obtained by the Construction Project Manager. The City's Office of Environmental Services may act as internal consultant to the City and County of Denver, Wastewater Capital Projects Management as needed.
2. Obtain the Construction Project Manager's approval of subgrade materials with respect to the City and County of Denver, Wastewater Capital Projects Management requirements before subsequent construction is performed.
3. Notify the City and County of Denver, Wastewater Capital Projects Management and the Environmental Consultant of conditions contrary to accepted requirements.
4. The Colorado Department of Hazardous Wastes Management Division (CDHWMD) is the state's agency for reviewing cleanup measures. Since the contaminants and their levels are unknown and the Colorado Department of Hazardous Wastes Management Division does not have specific regulations for cleanup of materials that may be found, they will only "suggest" or review cleanup measures. They will in some cases provide a letter suggesting that they concur with the levels selected but make no commitments regarding long-term liabilities. They will maintain a file on each project if the information is provided to them. The following cleanup levels will be used for the site, but may be modified by CDEVS or CDHWMD.

- Petroleum Product – 100 ppm TPH, 20 ppm BTEX (RACI)
- Metals (CERCLA, Ep-Tox or TCLP levels)
- Volatile and semi-volatile organics – 10 ppm total
- PCB's – 10 ppm (TSCA regulation)

Cleanup levels are determined on a case-by-case basis for contaminants not specifically regulated under Resource Conservation Recovery Act or Toxic Substances Control Act. The cleanup will be implemented using visual observation of stained areas and an established action level for PID readings in a headspace test of 50 ppm for petroleum contaminated soils and 10 ppm for organic contaminants. If either of these conditions are met, the material will be considered contaminated and stockpiled for sampling, analysis and appropriation of disposal or potential reuse.

5. Test Report: At least once a week prior to the work of this Section, submit test reports for the pre-construction testing performed by the Testing Laboratory.

14.0.7.5 Protection of Storm and Sanitary Sewers

1. Concrete Cut-off Walls as shown in figure 2 of the City and County of Denver, Wastewater Management Division, Standard Detail for Trenching and Bedding (S-301.1) shall be constructed upstream and downstream of the contaminated area to prevent migration of hazardous material from off-site areas.

End of Specification



CITY AND COUNTY OF DENVER
ENGINEERING DIVISION

Wastewater Capital Projects Management Standard Construction Specification

15.0 Manhole Rehabilitation

15.0.1 General

Manhole rehabilitation shall conform to this specification and one of the specific product subsections contained within these Standard Construction Specifications, as specified in the Contract Documents.

The purpose of manhole rehabilitation is to add structural stability to existing brick manholes and to stop infiltration / exfiltration of water/ sewage in the manhole

15.0.2 Preparation

- a. Safe access to the manhole shall be secured using appropriate traffic control devices. Gases within the manhole and associated sewer lines shall be checked for hazardous conditions. A positive flow ventilation system shall be installed to ventilate the manhole during construction.
- b. Prior to manhole barrel rehabilitation, a cover shall be placed over the manhole invert to prevent extraneous material from entering the sewer.
- c. All foreign materials shall be removed from the manhole walls and bench creating a sound surface for product application. Loose and protruding brick, mortar and concrete shall be removed and all voids filled using products specifically designed for that purpose and according to manufacturer's recommendations. All materials used must be submitted to and approved by the Construction Project Manger.
- d. Active leaks into or out of the manhole shall be stopped using mortar, grout or other products specifically designed for that purpose and in accordance with manufacturer's recommendations.

15.0.3 Manhole Barrel Rehabilitation

- a. All loose and broken concrete and brick will be removed from the manhole barrel prior to rehabilitation. No debris shall be allowed to enter the sanitary sewer.
- b. Remove manhole steps by cutting flush with vertical face of manhole wall prior to rehabilitation product application.

15.0.4 Manhole Invert Rehabilitation

- a. All loose and broken concrete and brick will be removed from the manhole invert prior to shaping. No debris shall be allowed to enter the sanitary sewer.
- b. The manhole invert shall be shaped per Wastewater Management Division Standard Detail Drawings.
- c. At a minimum, the material to be used for manhole invert rehabilitation shall be mortar or grout consisting of one part Type II Portland Cement and two parts of fine, clean sand. Only sufficient water shall be added to provide a stiff, workable cement mixture for proper trowelling. Hydrated lime or masonry cement shall not be used. Where thin layers of grout or mortar are to be applied in the manhole invert rehabilitation process, an approved epoxy coating shall be applied to the exposed concrete surfaces prior to grouting.

15.0.5 Manhole Testing and Inspection

- a. During application of the rehabilitation product a wet film thickness gauge shall be used to ensure a monolithic coating with uniform thickness.
- b. The Contractor, at his expense, shall provide all necessary labor, equipment and materials to re-inspect all rehabilitated manholes at two intervals: once at eighteen (18) months after the date of Final Inspection, and once an thirty-four (34) months after Final Inspection. A City and County of Denver representative will schedule the above inspections.

End of Specification



CITY AND COUNTY OF DENVER
ENGINEERING DIVISION

Wastewater Capital Projects Management Standard Construction Specification

**Approved for Specific Capital Projects Only - Product Must Be
Specifically Noted In the Contract Documents at Time of Bid**

This product is intended for Manhole Rehabilitation only

15.1 Cured-In-Place Fiberglass/Epoxy Resin

15.1.1 General

The work described within this specification details a complete manhole rehabilitation using a cured-in-place, fiberglass reinforced epoxy resin liner system. The complete system will provide a corrosion resistant liner to rehabilitate deteriorated manholes and prevent any further deterioration from hydrogen sulfide and other corrosive gases/acids caused by the wastewater stream. The completed system will also eliminate all ground water infiltration into the existing manholes.

15.1.2 Referenced Standards

ASTM D638 – Standard Test Method for Tensile Properties of Plastics

ASTM D695 – Standard Test Method for Compressive Properties of Rigid Plastics

ASTM D790 – Standard Test Methods for Flexural Properties of Unreinforced and Reinforced Plastics and Electrical Insulating Materials

ASTM D2240 – Standard Test Method for Rubber Property; Durometer Hardness

ASTM D4787 – Standard Practice for Continuity Verification of Liquid or Sheet Linings Applied to Concrete Substrates

ASTM G62 – Standard Test Methods for Holiday Detection in Pipeline Coatings

15.1.3 Submittals

1. All permits must be obtained by the Contractor, submitted to and approved by the Construction Project Manager prior to beginning any work; with any material. This includes, but is not limited to: Denver Fire Department (hazardous, flammable, hot work, confined space), Street Occupancy, Parks, Confined Space Entry, Hazardous and Flammable materials permits, etc.
2. A letter to the City’s Construction Project Manager requesting use of the product/system for a specific Capital Project must be approved in writing prior to product use.
3. Product Data: Technical data sheet for each product used; Material Safety Data Sheet (MSDS); design thickness.
4. Design Variations: Description of variations from application procedures, surface preparation, application equipment, or testing.
5. Applicator Qualifications:
 - a. Manufacturer Certification that the Applicator has been trained and approved in the handling, mixing and application of products to be used
 - b. Certification that the equipment to be used for applying the products has been manufactured or approved by the protective coating manufacturer and Applicator personnel have been trained and certified for proper use of the equipment.
 - c. Five (5) recent references for the Applicator (projects of similar size and scope) indicating successful application of cured-in-place, fiberglass reinforced epoxy resin liner system
 - d. Proof of federal, state or local permits or licenses necessary for the project.
6. Design details for any additional ancillary systems and equipment to be used in site and surface preparation, application or testing.

15.1.4 Quality Control and Assurance

1. Applicator shall initiate and enforce quality control procedures consistent with applicable ASTM, National Association of Corrosion Engineers (NACE) and SSPC standards and the protective coating manufacturer’s recommendations. All quality control testing is at the Contractor’s cost unless otherwise noted.

2. An NACE certified coating inspector shall be provided by the Owner. The Inspector will observe surface preparation, application and material handling procedures to ensure adherence to the specifications.

15.1.5 Delivery, Storage, and Handling

1. Materials are to be kept dry, protected for weather and stored under cover.
2. All materials should be stored in accordance with manufacturer's recommendations. Do not store near flame, heat or strong oxidants. Keep epoxy away from excessive heat to prevent premature curing.
3. Protective coating materials are to be handled according to their material safety data sheets.

15.1.6 Materials

1. Cured-in-Place Fiberglass Reinforced Resin Liner System: The Liner Manufacturer shall be as noted below, or an approved equal:

Poly-Triplex Technologies, Inc

495 St. Johns Road

Bonifay, Florida 32425

(850) 547-9999

www.Poly-triplex.com

2. The PTL5-5600 series is a three-layered composite system with a total pre-saturated fabric weight of 56-ozs. Per square yard. Layer #1 is 18-oz. structural fiberglass impregnated with a modified epoxy resin and bonded to the existing substructure. Layer #2 is a 20-oz. non-porous membrane of special synthetic materials bonded to layer #1 and layer #3. Layer #3 consists of 18-oz. structural fiberglass saturated with epoxy and bonded to the nonporous membrane, forming a smooth interior wall to the host structure.
3. Where active infiltration flows are more severe, pressure grouting may be required. The material for pressure grouting shall be Avanti A-220, DeNeef or approved substitute.

15.1.7 Equipment

Equipment used shall be as recommended by the liner manufacturer and adequate in size and capacity to accomplish the rehabilitation work in a timely manner.

15.1.8 Execution

1. Application shall be in strict accordance with the manufacturer's instructions (Refer to manufacturer's application instructions for additional details and recommendations not included herein). This shall include re-grouting all inlet and outlet lines and benches as needed, plus the preparation, installation, curing and finishing operation.
2. Use only skilled workmen who are trained and experienced in the installation of cured-in-place fiberglass reinforced epoxy resin liners for manhole rehabilitation. Contractor shall identify qualified personnel and ensure that these people are on site during each liner installation from start to finish.
3. All liner installations shall utilize bypass pumping. The use of flow-thru plugs and channel platforms shall only be allowed with prior approval from the Construction Engineer. Contractor shall provide individual flow diversion plans for each pumping setup.
4. No application shall be made to frozen surfaces or if freezing is expected to occur within 24 hours after application of product. No liners will be installed if outside air temperature exceeds 95 degrees F.
5. Do not allow extraneous material from entering sewer lines. Contractor will be fully responsible for any damage caused due to debris entering the sewer line during preparation work and/or liner installation activity.
6. Clean surfaces to be rehabilitated with high-pressure water spray (minimum 3500psi) to remove loose concrete or brick, biological growths, and other contaminants. If surface cannot be cleaned sufficiently with high-pressure water spray, then use means necessary, as recommended by manufacturer. Surfaces may require the application of a 10% solution of muriatic acid or the use of a detergent or degreaser. If an acid or detergent solution is used, the surface shall be thoroughly rinsed and neutralized prior to the installation of the liner system. All surfaces shall be clean and structurally sound. Loose and protruding brick, mortar, concrete and roots shall be removed.
7. Repair mortar shall be used to fill voids, structurally reinforce or rebuild surfaces. Rebuild bench and channel areas after cleaning using mortar or other approved material to ensure adequate surface prior to liner installation.
8. Stop all active hydrostatic infiltration with cementitious grout. Excessive infiltration may require the use of pressure grout and/or heavier liner.
9. Remove manhole steps by cutting flush with vertical face of manhole wall prior to CIPP rehabilitation product application.
10. Contractor shall make a reasonable effort to minimize odors emitting from open manholes during preparation work, liner installations, and inspections.

15.1.9 Installation

1. Rehabilitate manholes as identified on the drawings. Proper equipment shall be used at all times. Contractor shall observe OSHA confined space and safety requirements during all manhole entries.
2. Liner shall extend one (1) foot into pipelines where appropriate, to ensure adequate overlap with pipe materials unless otherwise indicated on the drawings.
3. The liner shall be installed and cured in place via a pressurization blower system with steam heat injection or equivalent process. Pressure shall be approximately 500 to 1000 lbs. per sq. ft. and steam at approximately 250 degrees Fahrenheit. Curing time shall be a minimum of two (2) hours or as recommended by the manufacturer. Liner may be rejected at the sole discretion of City's Construction Project Manager if curing process fails to meet manufacturer recommended procedures, or if installation bladder fails more than once during curing process.
4. Do not install cured-in-place fiberglass epoxy resin liners in no-round structures. Alternative lining methods will be required for the rehabilitation of vaults, diversion structures, or rectangular shaped manholes.
5. Repair any defects or irregularities in final product prior to acceptance.

15.1.10 Testing

Contractor shall perform visual inspection and necessary quality control testing. A Holiday test shall be performed according to ASTM standards. All tests and reports shall be in accordance with ASTM G62 and be submitted to the Construction Project Manager prior to final product acceptance. All hollow spots, holes, tears, or delaminations shall be promptly repaired using mastic epoxy or another method approved by the Construction Project Manager.

End of Specification



CITY AND COUNTY OF DENVER
ENGINEERING DIVISION

Wastewater Capital Projects Management Standard Construction Specification

**Approved for Specific Capital Projects Only - Product Must Be
Specifically Noted In the Contract Documents at Time of Bid**

This product is intended for Manhole Rehabilitation only

15.2 Spectrashield™ Manhole Liner

15.2.1 General

The work described within this specification details a complete program for manhole rehabilitation. This section details the methods, procedures, materials and equipment as required to produce “A Total System for Manholes”. The complete system will provide a corrosion resistant liner to rehabilitate deteriorated manholes and prevent any further deterioration from hydrogen sulfide and other corrosive gases/acids caused by the wastewater stream. The completed system will also eliminate all ground water infiltration into existing manholes.

15.2.2 Referenced Standards

ASTM 4541 – Standard Test Method for Pull-Off Strength of Coatings Using Portable Adhesion Testers

ASTM D412 – Standard Test Methods for Vulcanized Rubber and Thermoplastic Elastomers

ASTM D2240 – Standard Test Method for Rubber Property; Durometer Hardness

ASTM D522 – Standard Test Methods for Mandrel Bend Test of Attached Organic Coatings

ASTM D4060 – Standard Test Method for Abrasion Resistance of Organic Coatings by the Taber Abraser

CIGMAT Report (UH 1996-7) – Evaluation of Spectrashield Liner System for Wastewater Concrete and Clay Brick Facilities. University of Houston Department of Civil Engineering: December 1996

ASTM D4787 – Standard Practice for Continuity Verification of Liquid or Sheet Linings Applied to Concrete Substrates

ASTM G62 – Standard Test Methods for Holiday Detection in Pipeline Coatings

15.2.3 Submittals

All materials and procedures required to establish compliance with the specification shall be submitted to the City’s Project Manager for review/approval. Submittals shall include the following as a minimum:

1. All permits must be obtained by the Contractor, submitted to and approved by the Project Manager prior to beginning any work; with any material. This includes, but is not limited to: Denver Fire Department (hazardous, flammable, hot work, confined space), Street Occupancy, Parks, Confined Space Entry, Hazardous and Flammable materials permits, etc.
2. A letter to the City’s Project Manager requesting use of the product/system for a specific Capital Project must be approved in writing prior to product use.
3. Descriptive literature, bulletins and or catalogs of materials.
4. Work procedures including flow diversion plan, method of repair, etc.
5. Material and method for repair of leaks or cracks in manholes.
6. Final installation report on completed manholes

15.2.4 Quality Assurance

1. The manufacturer and/or installer of the total liner system of manholes shall be a company that specializes in the design, manufacture or installation of corrosion protection systems for manholes. Installer shall be completely trained in leak repair, surface preparation and corrosion materials application on manholes. Corrosion materials/products shall be suitable for installation in a severe hydrogen sulfide environment without any deterioration to the liner.
2. To ensure total unit responsibility, all materials and installation thereof shall be furnished and coordinated with/by one supplier/installer who turnkeys the work and assumes full responsibility for the entire operation.

15.2.5 Delivery, Storage and Handling

Handle and Store materials in accordance with manufacturer’s recommendations and MSDS.

15.2.6 Materials

Products shall be Spectrashield™, by CCI Spectrum, Inc.

1. The materials to be utilized in the lining of manholes shall be designed and manufactured to withstand the severe effects of hydrogen sulfide in a wastewater environment and eliminate all ground water infiltration. Manufacturer of corrosion protection products shall have long proven experience in the production of the lining products utilized and shall have satisfactory installation record.

15.2.7 Equipment

1. 3000 psi hydro blasting equipment shall be suited to remove corroded materials from the existing concrete/brick structure.
2. Equipment for installation of lining materials shall be high quality grade and be as recommended by the manufacturer.
3. The lining system to be utilized for manhole structures shall be a multi-component stress skin panel liner system as described below:

a. Liner

<u>Installation</u>	<u>Liner</u>
Moisture Barrier	Modified Polymer
Surfacer	Polyurethane/Polymeric Blend
Foam Final Corrosion Barrier	Modified Polymer

- b. Moisture Barrier - Modified polymer shall be sprayable, solvent free, two-component polymeric, and moisture/chemical barrier specifically developed for a corrosive wastewater environment. Typical chemical analysis is as follows:

<u>“A” Component</u>	
Viscosity, 77° F, cps, ASTM D-1638	300-400
Physical State	Liquid
Color	Clear to amber
Hygroscopicity	Reacts with water

<u>“B” Component</u>	
Viscosity, 160° F, cps, ASTM D-1638	400-600
Physical State	Liquid
Color	Flamingo Pink
Non-Volatile	100%

<u>Reaction Profile (100 grams, 175° F Sample)</u>	
Gel Time, Seconds	1-2
Tack Free Time, seconds	15
Cure Time, seconds	30

Processing

A System/B system, volume ratio 1.00/1.00

Typical Physical Properties

Tensile Strength, PSI	>1500
Elongation, %	>125
Tear Strength, PSI	350
Shore D Hardness	55-65
100% Modulus, PSI	>1500

c. Surfacers - Polyurethane Rigid Structure Foam, low viscosity two-component, containing flame retardants. Typical chemical analysis is as follows:

"A" Component

Viscosity, 77° F, cps, ASTM D-1638	200
Physical State	Liquid
Color	Dark Brown
Hygroscopicity	Reacts with water and evolves CO2 gas

"B" Component

Viscosity, 77° F, cps, ASTM D-1638	600-1000
Physical State	Liquid
Color	Tan
Hygroscopicity	Absorbs water rapidly thus changing ratio

Reaction Profile (100 grams, 77° F sample)

Cream Time, seconds	1-4
Tack free time, seconds	5-8
Rise Time, seconds	6-10

Processing

A System/B system, volume ratio 1.00/1.00

Typical Physical Properties

Density, nominal, core, lbs/ft3 ASTM D-1622 @ 74° F	4-10
Compression Strength, ASTM D-1621 @ 74° F parallel rise; PSI	90-150
Closed Cell Content, % - ASTM 1940 @ 74 °	Over 90
Shear Strength, PSI – ASTM C-273 @ 74° F	225-250

d. Final Corrosion Barrier - Total thickness of multi-component stress skin panel liner shall be a minimum of 500 mils.

15.2.8 Execution

15.2.8.1 Initial Inspection

1. Prior to conducting any work, perform inspection of structure to determine need for protection against hazardous gases or oxygen depleted atmosphere and the need for flow control or flow diversion.
2. Submit plan for flow control or bypass to owner/engineer for approval prior to conducting the work. Cost of flow control or bypass shall be included in cost of the manhole rehabilitation.

15.2.8.2 Surface Preparation

1. Conduct surface preparation program to include monitoring of atmosphere for hydrogen sulfide, methane, low oxygen or other gases, approved flow control equipment, and hydro blasting equipment.
2. Remove manhole steps by cutting flush with vertical face of manhole wall prior to rehabilitation product application.
3. Hydro blasting equipment shall remove all corrosion from structure. Final product shall be a cleaned, dry surface ready for liner application.
4. After completion of surface preparation, blasting phase, perform the seven point check list, which is the inspection for:
 1. Leaks
 2. Cracks
 3. Holes
 4. Exposed Rebar
 5. Ring and Cover condition
 6. Invert Condition
 7. Inlet and Outlet Pipe Condition
5. After the defects in the structure are identified, repair all leaks with a chemical or hydraulic sealant designed for used in field sealing of ground water. Severe cracks shall be “repaired with a urethane based chemical” sealant. Product to be utilized shall be as approved by owner/engineer prior to installation. Repairs to exposed rebar, defective pipe penetrations or inverts, etc. shall be repaired utilizing non-shrink grout or approved alternative method.
6. Benches, walls and floors shall be repaired or refinished as necessary to comply with Wastewater Management Division Standard Detail Drawings (Drawing No. S-502) using chemical grout, hydraulic cement or Portland type II cement. Bench areas and floors shall be lined with Spectrashield™.

15.2.8.3 Material Installation

1. The limits of the corrosion protection system shall include all exposed concrete/brick surfaces including walls, tap sections, risers, benches etc., unless otherwise directed by the owner/engineer.
2. Application of multi-component system shall be in strict accordance with manufacturer's recommendation. Final installation shall be a minimum of 500 mils. A permanent identification number and date of work performed shall be affixed to the structure in a readily visible location.
3. Provide final written report to owner/engineer detailing the location, date of report, and description of repair.

15.2.8.4 Final Inspection & Testing

1. Final concrete/brick structure corrosion protection system shall be completely free of pinholes or voids and all ground water infiltration shall be completely eliminated. A Holiday test shall be performed according to ASTM standards. All reports shall be performed in accordance with ASTM G62 and be submitted to the Construction Project Manager. Liner thickness shall be the minimum value described within this specification.

End of Specification



CITY AND COUNTY OF DENVER
ENGINEERING DIVISION

Wastewater Capital Projects Management Standard Construction Specification

**Approved for Specific Capital Projects Only - Product Must Be
Specifically Noted In the Contract Documents at Time of Bid**

This product is intended for Manhole Rehabilitation only.

15.3 High Build Novolac Epoxy

15.3.1 General

The work described within this specification details a complete program for trowel applied liner coating for sewer piping and manholes for new construction and remedial work.

15.3.2 Referenced Standards

ASTM D638 – Standard Test Method for Tensile Properties of Plastic.

ASTM D695 – Standard Test Method for Compressive Properties of Rigid Plastic.

ASTM C722 – Standard Specification for Chemical Resistant Resin Monolithic Surfaces.

ASTM D790 – Standard Test Method for Flexural Properties of Un-reinforced and Reinforced Plastics and Electrical Insulating Materials.

ASTM D1763 – Standard Specifications for Epoxy Resins.

ASTM D2240 – Standard Test Method for Rubber Property-Durometer Hardness.

ICRI Guidelines NO. 03732 – Selecting and Specifying Concrete Surface Preparation for Sealers, Coatings, and Polymer Overlays.

15.3.3 Submittals

1. A Denver Fire Department permit (Hazardous, Flammable, Hot Work, Confined Space) must be obtained by the contractor prior to beginning any work; with any material.

2. A letter to the City's Construction Project Manager requesting use of the product/system for a specific Capital Project, must be approved in writing prior to product use.
3. Product Data: Technical data sheet for each product used; Material Safety Data Sheet (MSDS); design thickness.
4. Design Variations: Description of variations from application procedures, surface preparation, application equipment, or testing.
5. Quality Assurance/Control: Submit certifications as required under Article 15.3.4 – Quality Assurance.
6. Test Reports: Submit test reports from an independent testing laboratory confirming chemical resistance.
7. Plan to prevent debris from entering sewer line

15.3.4 Quality Assurance

- A. Applicator Qualifications: Trained and certified by Liner Coating Manufacturer. The coating applicator shall submit three (3) references relating to the quality of workmanship performed on other projects using one or more of the coatings listed below, or an approved equivalent coating.

15.3.5 Materials

Product shall be Sewer-Shield® 100 or Sewer-Shield ®150 as manufactured by Environmental Coatings 4702 E. Virginia St., Mesa, Arizona 85215-9101, (480) 984-7608.

- A. Trowel Applied Liner Coating:
 1. Acid Resistance:
 - a. Resistant to 98% sulfuric acid with maximum weight loss in 18 months no greater than 0.08 percent. (Sewershield® 100)
 - b. Resistant to 50% Sulfuric Acid (Sewershield® 150)
 2. Gel Time: 15 minimum minutes at 75 degrees Fahrenheit using a 200 gram mass. Shorter gel times are not acceptable since they will not allow for proper adhesion to substrate.
 3. Fillers:
 - a. Description: Chemical resistant, non wicking type. Fiberglass filler/roving is not acceptable.
 - b. Size: Pass 40 mesh screen.
 - c. Quantity: Not to exceed 20% (+/- 1%) in volume.
 4. Thickness:
 - a. Typical: 3/16 inch.
 - b. Material shall be capable of being applied up to 3/8 inch thickness in one application without sagging.

5. Tack Free Time: Obtained in minimum one hour, and maximum 6 hours at 75 degrees Fahrenheit.

15.3.5.1 Accessories

- A. Water Stop Grout:
 1. Material: Hydrophobic polyurethane liquid which when mixed with catalyst, expands when it meets water or moisture.
 2. Acceptable Manufacturer and Product: **Mountain Grout® - Regular** as manufactured by Green Mountain, Inc. and distributed by Environmental Coatings, 4702 E. Virginia St., Mesa, Arizona 85215-9101, (480) 984-7608 is an acceptable product, or an approved equal.

- B. Patching Compound: Sewer-Shield® Products may require structural build-back using C-120 Calcium Aluminates mortar.
 1. Material: Calcium aluminate cement.
 2. Thickness:
 - a. Typical: 0.75 inches to 2 inches.
 - b. Material shall be capable of being applied up to 4 inches thick.
 3. Acceptable Manufacturer and Product: **Sewer-Shield® C-120 Acid - Resistant Underlayment** as manufactured by Environmental Coatings, 4702 E. Virginia St., Mesa, Arizona 85215-9101, (480) 984-7608 is an acceptable product, or approved equal.
 4. Refer to Section 02942 – Calcium Aluminate Mortar.

- C. Curing Primer:
 1. Material: 100% solids, solvent free epoxy curing primer designed to act as a curing compound for "green" concrete.
 2. Acceptable Manufacturer and Product: **Corro-Cure®** as manufactured by Environmental Coatings, 4702 E. Virginia St., Mesa, Arizona 85215-9101, (480) 984-7608 is an acceptable product, or approved equal.

15.3.6 EXECUTION

15.3.6.1 Initial Inspection

- A. Verification of Conditions:

1. Examine subsurfaces to receive Work and report detrimental conditions in writing to Construction Project Manager. Commencement of Work will be construed as acceptance of subsurfaces.
- B. Coordination: Coordinate with other work, which affects, connects with, or will be concealed by this Work.

15.3.6.2 Surface Preparation

- A. Water Infiltration Remediation (if required): Mix and install specified Water Stop Grout in accordance with manufacturer's instructions if required to fill fissures or voids which are allowing water to infiltrate or exfiltrate into unwanted areas.
- B. Cleaning: Pipes and manholes surfaces to receive liner coatings shall be cleaned with high-pressure water vacuum equipment to remove debris. Recommended minimum cleaning pressure is 4,000 psi for Patching Compound.
- C. Surface Preparation:
 1. Concrete and masonry substrates:
 - a. Power wash surfaces using a minimum of 4,000 psi. Sandblast to sound concrete or masonry and to expose "bug holes."
 - b. If required, apply specified manufacturer's approved Patching Compound from 3/4 inch to 2 inches thick (4 inch maximum) to provide a smooth surface.
 - c. Green Concrete (less than 28 days old): Apply specified Curing Primer in accordance with manufacturer's printed instructions.
 2. Apply epoxy primer/sealer coat or specified Curing Primer to fill "bug holes" and to provide a smooth surface for application of liner coating.
 3. Prior to application of Patching Compound, structure surface shall be adequately sand blasted and roughened. (ICRI Level 5 surface preparation).
 4. Surface preparation of concrete for Liner Coating applied without Patching Compound shall be determined on a case-by-case basis.
 5. Remove manhole steps by cutting flush with vertical face of manhole wall prior to rehabilitation product application.
 6. Benches, walls and floors shall be repaired or refinished as necessary to comply with Wastewater Management Division Standard Detail Drawings (Drawing No. S-502) using chemical grout, hydraulic cement or Portland type II cement. Bench areas and floors shall be lined with Sewer-Shield.
- D. Structure must be dry during product application. Infiltration & moisture must be controlled prior to application of Patching Compound, Curing Primer, and Liner Coating products.
- E. Do not allow extraneous material to enter sewer lines. Extraneous material is defined as soft concrete debris, construction debris, or other materials. Active flows shall be diverted as necessary to ensure that the liquid flow is maintained off the surfaces to be lined. Contractor shall provide submittal explaining how they will prevent debris from entering live flow.

15.3.6.3 Material Installation

- A. Trowel applied liner coating:
 - 1. Provide at benches and channel walls.
 - 2. Provide at smaller manholes that are not accessible to spray equipment.

- B. Spray application of protective coatings may be allowed if the process and spray equipment being proposed complies with coating manufacturers recommendations, and meets or exceeds quality standards as noted for trowel-applied product.

- C. Certified Applicators or approved substitution:
 - 1. JPCI Services
Contact: Joe Nuciforo
4702 E. Virginia St.
Mesa, AZ 85215-9101
480-984-7608 (phone)
480-380-4461 (fax)
www.josephpainting.com

 - 2. Quality Linings and Painting
8250 East 40th Avenue
Denver, Colorado 80207
303-307-1313 (phone)
303-307-1302 (fax)
www.qlapi.com

15.3.6.4 Testing and Inspection

- A. Surface preparation work shall be thoroughly inspected by Construction Project Manager prior to application of coating or lining. The Contractor may not proceed with rehabilitation product application until surface preparation work is approved by Construction Project Manager. All structures shall be inspected from the surface to ensure adequate surface preparation has been achieved. A minimum surface roughness profile equivalent to ICRI-4 is required for all coatings/linings. The Contractor is expected to cooperate and assist with the City's inspection efforts.

- B. The Construction Project Manager shall inspect all structural repairs made during the surface preparation process. Any structural repair deficiencies identified by the Construction Project Manager shall be corrected prior to rehabilitation product application.

- C. Contractor shall perform holiday (spark) test on all rehabilitated structures prior to restoration of service with test equipment and voltage appropriate for coating/lining.

Voltage is to be set at a minimum of 100 volts per mil of coating/lining thickness (i.e., 12,500 volts for 125 mils). After identification of pinholes, thin areas, or other imperfections, re-apply coating/lining material within manufacturer recommended recoat time window. Retest. Repeat until no holidays are identified. The Construction Project Manager shall verify voltage and observe final holiday testing performed by Contractor.

- D. A comprehensive visual surface inspection shall be performed by Construction Project Manager for all rehabilitated structures. The finish of the protective coating shall be smooth and uniform, pin hole free, acceptable to City inspections. Construction Project Manager may, at his/her discretion, perform additional entry inspections as deemed necessary. Construction Project Manager reserves the right to reject sub-standard workmanship.

15.3.6.5 Cleaning

- A. During the course of the Work and on completion of the Work, remove and dispose of excess materials, equipment and debris away from premises. Leave Work in clean condition.

End of Specification



CITY AND COUNTY OF DENVER
ENGINEERING DIVISION

Wastewater Capital Projects Management Standard Construction Specification

20.0 Grass Sodding

20.0.1 General

This item shall consist of placing grass sodding and fertilizing in conformity with the lines, grades and cross sections shown on the plans, stakes established by the Construction Project Manager, and in accordance with these Standard Construction Specifications.

The equipment and methods described in these Standard Construction Specifications may be modified where it is established to the satisfaction of the Construction Project Manager that the resultant product is equivalent to that specified herein.

20.0.2 Materials

20.0.2.1 Sod

Sod shall be Kentucky bluegrass and shall be approved by the Parks and Recreation Department before placement. At least 99% of the plants in the sod shall be of the variety specified. The sod shall be materially free from weeds or undesirable plants and stones larger than 1 inch in diameter. Sod shall be nursery grown and shall be mowed to a height not to exceed 2 inches before lifting and shall be of a uniform thickness with not over 1-1/2 inches soil or less than 1 inch of soil.

Delivered sod shall not contain more than 5% broken rolls. Sod shall be laid within 24 hours from the time it is lifted from the field.

Sod that has become moldy, withered, or yellow from storage or white from drying will be rejected at the time of planting. Rejected sod will not be counted for payment.

20.0.2.2 Fertilizers

The area to be sodded shall be fertilized as follows:

- a. Well rotted cow manure shall be roto-tilled into the topsoil prior to sod placement.
- b. In general commercial fertilizer consisting of 20% nitrogen, 20% available phosphoric acid and 10% water soluble potash is acceptable. Commercial fertilizers shall be applied after the sod is laid and shall be a complete formulation or organic base, granular and free flowing.

20.0.2.3 Topsoil

Topsoil may be selected from the material excavated at the job site by the Construction Project Manager and placed where needed to provide a 4inch minimum friable, fertile loam

root-moisture zone. During the excavation operation, the acceptable on-site topsoil shall be removed and stockpiled in the area. Upon completion of the construction, the topsoil shall be placed to the correct line and grade in all areas requiring sodding and seeding. Topsoil will not be required in areas of special slope protection noted on the plans, in paving areas or other structures.

In the event the topsoil available from project excavation is insufficient, in the judgement of the Construction Project Manager, the Contractor shall import suitable topsoil in conformance with the select material requirements in section 5.0 of these Standard Construction Specifications. Payment for on-site or imported topsoil shall be as noted in the Measurement and Payment Section of these Standard Construction Specifications.

20.0.3 Construction

20.0.3.1 Time

The Contractor shall place the sod between March 1 and November 1 of the Calendar year of construction. No sod shall be laid on frozen soil.

20.0.3.2 Site Preparation

The area to be sodded shall be cleared of all stones, roots, wood, weeds, and any other materials that may hinder proper grading, tilling, sodding, or subsequent maintenance, operations and shall be smooth before any sod is laid.

After the cow manure has been roto-tilled into the topsoil as specified in Subsection 20.3.4 below, fine grading shall be performed to insure reasonable grades and alignments per the grade stakes. Where no grade stakes are shown, areas shall be smooth and of continual grade between control points, such as walks and curbs. Areas of settlement shall be filled with topsoil and properly rolled to insure a firm bed true to the proposed grades. Areas of compacted soil, which are, in the judgment of the Construction Project Manager, too hard to serve as suitable subgrade, shall be scarified to a depth of six inches, and leveled and rolled.

After the fine grading operations have been completed, the entire area to be sodded shall be rolled with a 100 pound roller prior to sod placement.

20.0.3.3 Sod Placement

Sod shall be laid on a smooth, firm earth bed with staggered, tight joints. Care should be exercised to avoid air voids along the joints and at end sections. Sections of sod that leave more than 1/2 inch joints opening shall be filled with a screened topsoil. Exposed edges shall be mounded with topsoil.

The sod shall be laid with staggered joints and shall run parallel to a 90-degree angle to the slope of the ground. If the slope is steeper than 2:1, the prepared sod bed shall be lightly and sufficiently watered prior to placement of the sod.

All sod laid slopes within 4 vertical feet of the flow line of open channels, gulches, etc. shall be held in place with 12 gauge u-shaped metal pins, minimum one inch in width, eight inches long driven flush with the top of the root zone. Prior to pinning, a 12" wide strip of 20 gauge 2" galvanized wire netting shall be placed at each corner and one in the center of each perpendicular edge (3 pins/1e" wide roll). Care shall be taken to insure that each pin will secure the wire netting to the sod. Pins shall be driven at intervals not greater than one foot

from beginning to end of the roll and at each grade change in the slope. All sod shall be laid parallel to the center line of the channel.

20.0.3.4 Fertilizer Placement

Fertilizing accomplished in a two step operation as follows:

- a. Cow manure shall be spread over the surface of the ground of the areas to be covered at the minimum rate of one (1) cubic yard per thousand (1,000) square feet. The areas shall then be thoroughly roto-tilled to a depth of from a minimum of 4 inches to a maximum of 6 inches until no manure appears on the surface.
- b. Commercial Fertilizer shall be uniformly applied after the sod has been laid at the rate of 10-pounds per 1,000 square feet of coverage or as recommended by the fertilizer manufacturer. The method of application shall be subject to approval by the Construction Project Manager.

20.0.3.5 Maintenance

The Contractor shall be responsible for watering and mowing the sodded areas. Watering shall be performed periodically to insure a uniform root extension into the bed root--moisture zone. Mowing shall be performed to limit maximum grass height to three (3) inches and cut length of one and one-half (1-1/2) inches.

The maintenance period for sod shall continue for 90 days after notification in writing to the Construction Project Manager of the completion of sodding and the owner's initial approval. During this 90-day period the sod shall be kept growing and in place, and any movement or dead grass shall be replaced to the satisfaction of the Construction Project Manager. During this period, the sod's condition shall show normal to good progress so as to constitute an acceptable planting by the owner's representative. Watering shall be as required. If the planting within the reasonable care of the contractor does not show acceptable progress during this period, the areas affected shall be resodded, fertilized as required and growth progress repeated until results are obtained. This reworking shall be at the contractor's expense. If the planting is damaged or otherwise hindered due to causes beyond the contractor's control such as inclement weather or vandalism, the contractor shall rework the planting according to the item in the Measurement and Payment Section of these Standard Construction Specifications.

End of Specification



CITY AND COUNTY OF DENVER
ENGINEERING DIVISION

Wastewater Capital Projects Management Standard Construction Specification

22.0 Seeding

22.1.1 General

This work shall consist of furnishing and drilling in seed or hydromulch seeding in accordance with these Standard Construction Specifications and as shown on the Plans. The work shall also include soil preparation, furnishing and spreading fertilizer and installation of mulch and erosion control blanket.

All areas shall be seeded by drilling. In areas where access is a problem, seeding shall be conducted by hydromulch seeding as directed by the Construction Project Manager. Mulch shall be required in all areas that are drilled.

Seeding and the installation of erosion control in certain areas designated by the Construction Project Manager may be permitted before the construction of certain areas to take advantage of growing conditions.

Seeding shall not be accomplished when the ground is frozen or otherwise untiltable.

Seeded areas damaged due to circumstances beyond the Contractor's control shall be repaired and reseeded as ordered. Payment for this corrective work shall be at the contract price.

22.1.2 Grading

All areas requiring seeding shall be cleared of vegetation, roots, oversized materials and all other material which is objectionable in the opinion of the Resident Engineer and shall be disposed of as specified in Section 2.0, Site Preparation.

22.2 Materials

22.2.1 Seed

All seed shall be furnished in bags or containers clearly labeled to show the name and address of the supplier, the seed name, the lot number, net weight, the percentage of purity and germination. All brands furnished shall be free from such noxious seeds such as Russian or Canadian Thistle, European Bindweed, Johnson Grass and Leafy Spurge. All seed furnished shall be from a lot that has been tested by a recognized laboratory for seed testing within six months prior to the date of delivery. Seed which has become wet, moldy, or otherwise damaged in transit or in storage will not be acceptable.

Seed Type. The seeds acceptable for drilling and hydromulch seeding are: (1) White Dutch Clover, (2) Fairway Wheatgrass, (3) Perennial Rye, (4) “Sodar” Streambank Wheatgrass, and (5) Luna Pubescent or Western Wheatgrass.

Seeding Mixture. The seeding mixture shall be applied at a bulk rate per acre as follows for hydromulch seeding:

	Pounds	Purity	Germination
(1) White Dutch Clover	1.1	96%	90%
(2) Fairway Wheatgrass	2.9	95%	85%
(3) Perennial Rye	3.5	98%	90%
(4) Sodar Streambank Wheatgrass	5.2	97%	92%
(5) Luna Pubescent Wheatgrass	8.9	93%	85%
(6) Western Wheatgrass	10	80%	80%

The seeding rate per acre for drilling shall be one-half the rate of hydromulch seeding.

- c. Seed Purity. Seed and seed labels shall conform to all current State and Federal regulations and will be subject to the testing provisions of the Association of Official Seed Analysis.

If seed available on the market does not meet the minimum purity and germination percentages specified, the Contractor must compensate for a lesser percentage of purity of germination by furnishing sufficient additional seed to equal the specified product. Product comparison shall be made on the basis of pure live seed in pounds. The formula used for determining the quantity of pure live seed (PLS) shall be:

$$\text{Pounds of Seed} \times (\text{Purity} \& \text{Germination}) = \text{Pounds of Live Seed (PLS)}$$

21.2.2 Fertilizers

Fertilizers shall consist of a standard brand fertilizer having a minimum content of 18% available nitrogen. The percentage of nitrogen content shall be certified at the time of use.

Super Phosphate (45% minimum Phosphate when called for on the Plans) will be used on subsoil where all topsoil has been removed. The rate of application shall be approximately 250 pounds per acre.

22.2.3 Erosion Control Blanket

Erosion Control Blanket. The blanket shall consist of a material or combination of materials that are biodegradable after a sufficiently long enough period of time to insure germination and rooting of grass seeds. The blanket shall have uniform openings and consist of knitted yarn in a material that has enough strength and flexibility that allows it to be placed over uneven ground surfaces. The erosion control blanket shall be furnished in rolls that have a width of 4’ minimum to 10’ minimum. Length and weight of the rolls may vary depending on the manufacturer and the blanket material.

Pins and Staples. Pins or staples shall be made of wire .091” or larger in diameter. “U” shaped staples shall have legs 6” long and 1” crown.” T” shaped pins shall have a minimum

length of 8” after bending. The bar of the “T” shall be at least 4” long with the single wire end bent downward approximately ¾”.

22.2.4 Tackifier

A tackifier will be required with all hydromulch seeding.

22.2.5 Hydromulch

Wood cellulose fiber for hydromulch seeding shall not contain any substance or factor, which might inhibit germination or growth of grass seed. It shall be dyed an appropriate color to allow metering of its application.

The wood cellulose fibers shall have the property of becoming evenly dispersed and suspended when agitated in water. When sprayed uniformly on the surface of the soil, the fibers shall form a blotterlike ground cover, which readily absorbs water, and allows infiltration to the underlying soil. Weight specifications from suppliers, and for all applications, shall refer only to air dry weight of the fiber, a standard equivalent to ten (10%) percent moisture. The mulch material shall be supplied in packages having a gross weight not in excess of one hundred (100) pounds, and shall be marked by the manufacturer to show the air dry weight content. Suppliers shall certify that the laboratory and field testing of their product has been accomplished and that it meets all of the foregoing requirements pertaining to wood cellulose fiber mulch.

22.2.6 Mulch

Materials for straw mulch shall consist of straw of oats, barley, wheat, or rye and shall not contain seed of noxious weeds.

Straw or hay in such an advanced stage of decomposition as to smother or retard the normal growth of grass will not be accepted. Old dry straw which breaks in the crimping process in lieu of bending will not be accepted.

22.3 Construction

22.3.1 Grade Preparation

Prior to seeding, the top 4 inches of the surface shall be tilled and brought to the desired line and grade, except where seeding follows so closely behind the initial grading as to make special seeding preparation unnecessary. Areas to be seeded shall be tilled or handworked into a reasonably even and loose sandbed immediately in advance of the seeding.

22.3.2 Seeding

Hydromulch Seeding. As required, cellulose fiber mulch shall be added with the proportionate quantities of water and other approved materials in the slurry tank. All ingredients shall be mixed to form a homogeneous slurry. Using the color of the mulch as a metering agent, the operator shall spray-apply the slurry mixture uniformly over the designated seeded area. Unless otherwise ordered for specific areas, wood cellulose fiber mulch shall be applied at the rate of 1500 pounds per acre or 35 pounds per 1,000 square feet.

Hydromulch seeding shall not be done in the presence of free surface water resulting from rains, melting snow or other causes.

Drilling. Seeding shall be accomplished by means of an approved mechanical power drawn drill, followed by packer wheels or drag chains. Seed shall not be drilled during windy weather or when the ground is frozen or otherwise untillable.

Mechanical power drawn drills shall have depth bands set to maintain a planting depth recommended for the type of seed being drilled and shall be set to space the rows not more than 7 inches apart.

If the inspections indicate the stripe wider than the specified space between the rows planted have been left or other areas skipped, the Construction Project Manager shall require immediate re-sowing of seed in such areas at the Contractor's expense.

All seeding shall be done between September 1 to September 15 and March 2 to April 15 of the Calendar year of construction.

The Contractor shall be responsible for maintaining and watering areas seeded for a period of 7 weeks after the time of seeding. Areas in which there is not a satisfactory stand at the expiration of this 7-week period shall be re-seeded. Sprinkling of the seeded areas shall be carefully done in such a manner as to avoid standing water, surface wash or scour. Areas seeded and so maintained shall be protected against damage by vehicle or pedestrian traffic by the use of barriers and appropriate warning signs. Areas shall be re-seeded as many times as is required to establish a significant growth of grass seedlings (a minimum of 25 plants per square feet).

22.3.3 Mulch

After seeding has been completed, a rate of 11/2 tons of hay or straw per acre, or as directed, shall be applied uniformly, crimped in with a crimper or other approved equipment. The Construction Project Manager may order the employment of hand crimping operations on such areas where excessive ground slopes or confined areas would cause unsatisfactory crimping by mechanical methods.

The seeded area shall be mulched and crimped within 24 hours after seeding. Areas not mulched and crimped within this 24-hour period must be reseeded with the specified seed mix at the Contractor's expense prior to mulching or crimping.

On steep slopes or other specific areas as shown on the plans, which are difficult to mulch or crimp by conventional methods, burlap or other blanketing materials properly anchored or secured may be used when approved by the Construction Project Manager.

22.3.4 Fertilizer

Fertilizer shall be spread uniformly at the rate specified and washed into the soil by the application of water or tilled into the top two inches of soil. Sufficient fertilizer shall be evenly distributed to provide 50 pounds of free nitrogen per acre.

22.3.5 Erosion Control Blanket (Channels, Etc.)

Erosion control blanket shall be installed on each side and bottom of the low flow channel as shown on the drawings and as directed by the Construction Project Manager. An additional row of blanket (approximately 4' to 5' wide) may be required in areas of steep slopes or southern exposures.

The area to be covered shall be properly prepared, fertilized and seeded before the erosion control blanket is applied. The blanket shall be placed in accordance with the manufacturer's recommendations and in such a manner to insure contact with the ground creating maximum protection for the newly planted seed. In the low flow channel, the erosion control blanket shall be applied in the direction of the flow of the water, butted snugly at the sides and lapped approximately one foot. On slopes the blankets may be applied either horizontally or vertically to the slope as directed by the Construction Project Manager. Ends and sides shall be butted snugly. The blanket shall be stapled down at intervals in accordance with the manufacturer's specifications.

The Contractor shall also be responsible for maintaining and caring for the erosion control blanket for a 7-week period. All blankets that are disturbed during this period will be replaced and restapled by the Contractor.

End of Specification



CITY AND COUNTY OF DENVER
ENGINEERING DIVISION

Wastewater Capital Projects Management Standard Construction Specification

23.0 Storm Water Management

23.0.1 Definitions

Definitions used for this Section shall consist of those listed in Title 1 of the City and County of Denver "Standard Specifications for Construction, General Contract Conditions" as referenced within the Contract Documents, those listed within the City and County of Denver Construction Activities Stormwater Manual (CASM), and the following:

23.0.1.1 Basis of Payment

The terms under which Work is paid, as a designated Pay Item, in accordance with the quantity measured and based upon the associated Measurement and Payment description.

23.0.1.2 Best Management Practices (BMPs)

Schedules of activities, prohibitions of practices, installation of devices, maintenance procedures, and other management practices deployed to stabilize the construction site to prevent or reduce the pollution of State Waters (see definition below). Stormwater BMPs can be classified as "structural" (i.e., devices installed or constructed on a site) or "non-structural" (procedures, such as modified landscaping practices).

23.0.1.3 Colorado Department of Health and Environment (CDPHE)

State of Colorado, Water Quality Control Division responsible for issuance of State Construction Stormwater Permit.

23.0.1.4 Construction Activities Stormwater Discharge Permit (CASDP)

Permit issued by the City for compliance with City & County of Denver Revised Municipal Code and Department of Public Works Rules & Regulations concerning the discharge of pollutants in storm generated runoff from construction sites to Municipal Separate Storm Sewer System (MS4, see definition below) or State Waters, via the Municipal Separate Storm Sewer System (MS4).

23.0.1.5 Construction Activities Stormwater Manual (CASM): City and County of Denver Construction Activities Stormwater Manual (CASM), current edition.

23.0.1.6 Colorado Department of Transportation (CDOT)

State agency that has published standards for Erosion Control with accompanying Erosion Control Supervisor certification courses.

23.0.1.7 Erosion Control Supervisor (ECS)

The Contractor's Erosion Control Supervisor, to perform duties as described in this Section. The ECS shall be properly trained in BMPs per requirements of Part V below, and shall be under the direction of a Professional Engineer licensed in the State of Colorado when performing any modifications to the Project Stormwater Management Plan (SWMP).

23.0.1.8 Final Stabilization

Point of construction when all ground surface disturbing activities at the site have been completed and uniform vegetative cover has reached 70% of pre-disturbance vegetative cover, or equivalent permanent features have been employed. At this point, all temporary BMPs can be removed, all construction and equipment maintenance wastes have been disposed of properly; and all elements of the Stormwater Management Plan have been completed.

23.0.1.9 Major SWMP Modification

Changes to the original SWMP that removes or adds additional area to the Project, or modifies the final hydrology or drainage of the Project. A Major SWMP Modification requires the submission of revised Storm water Management Plan (SWMP) elements to the Permit Authority for review and approval. Any adjustments to a SWMP must be performed either by or under the direction of a Professional Engineer licensed in the State of Colorado.

23.0.1.10 Minor SWMP Modification

Modification to the SWMP that does NOT increase the scope or change hydrology of the Project but: modifies/improves specific BMPs in use at site, indicates progression in phasing of the Project, or specifies relocation of previously approved BMPs within the Project. Any adjustments to a SWMP must be performed either by or under the direction of a Professional Engineer licensed in the State of Colorado.

23.0.1.11 Municipal Separate Storm Sewer System (MS4): A conveyance or system of conveyances (including roads with drainage systems, municipal streets, catch basins, curbs, gutters, ditches, man-made channels, or storm drains):

- a) owned or operated by a State, city, town, county, district, association, or other public body (created by or pursuant to State law) having jurisdiction over disposal of storm water or other wastes, including special districts under State law such as a sewer district, flood control district or drainage district, or similar entity, or a designated and approved management agency under Section 208 of the Federal Clean Water Act that discharges to State Waters;
- b) designed or used for collecting or conveying storm water;
- c) which is not a combined sewer; and
- d) which is not part of a Publicly Owned Treatment Works (POTW).

23.0.1.12 Permit Authority

The Department authorized by the City to review and process CASDP Applications for Capital and/ or governmental sponsored Projects. The responsible City department serving as the Permit Authority is the Public Works Project Controls Office. As a clarification, the Development Services Department of the City serves as the point of intake and permit processing center.

23.0.1.13 Permit Enforcement Authority

The Department authorized by the City to inspect and enforce CASDP Rules and Conditions for all construction Projects within the City's MS4 Boundary. The responsible City department serving as the Permit Enforcement Authority is the Wastewater Management Division of the Department of Public Works.

23.0.1.14 State Construction Stormwater Permit

Colorado Revised Statutes require that all construction sites/development Projects, which, by definition, disturb one or more acres in area, shall be covered by a State issued general permit for construction activities. Information on the application requirements for the State permit can be obtained by phone at 303-692-3500; or by visiting their offices located at 4300 Cherry Creek Drive South, Denver, CO 80246 – 1530 or on the Web at: www.cdphe.state.co.us

23.0.1.15 State Waters

Any and all surface waters which are contained in or flow in or through this State, not to include waters in sewage systems, waters in treatment works of disposal systems, waters in potable water distribution systems, and all water withdrawn for use until use and treatment have been completed. Examples of State Waters include, but are not limited to, perennial streams, intermittent or ephemeral gulches and arroyos, ponds, lakes, reservoirs, irrigation canals or ditches, wetlands, stormwater conveyances (when they discharge to a surface water), and groundwater.

23.0.1.16 Substantial Completion of Erosion Control

Point of construction when permanent BMPs have been installed, initial growth is in place, and the site is waiting for vegetative cover to reach 70% of pre-disturbance vegetative cover.

23.0.1.17 Stormwater Management Plan (SWMP)

A SWMP establishes a minimum standard to construct, install, maintain, and remove required BMPs during the life of the Contract to prevent or minimize pollution of stormwater due to erosion, sediment transport, and construction related pollutant generated during all phases of the Project.

23.0.2 General

This Work shall consist of constructing, installing, maintaining, and removing when required, BMPs during the life of the Contract until Final Stabilization to prevent or minimize erosion, sedimentation, and pollution of any waters including storm, drainageways, MS4, State Waters, and/ or wetlands. Work under this Section includes the Contractor obtaining required Permits, utilizing SWMP elements provided in the Contract, and/ or SWMP elements specifically prepared by the Contractor as defined herein. The work shall also consist of providing on-going maintenance and monitoring of the SWMP as may be necessary due to the specific

and/or dynamic needs of the Project as well as meet all requirements set forth within the CASM.

The Contractor shall coordinate the construction of temporary BMPs with the construction of permanent BMPs to assure economical, effective, and continuous erosion and sediment control and water pollution prevention throughout the construction period until Final Stabilization is achieved

When a provision of this Section or an order by the Permit Enforcement Authority requires that an action be immediate or taken immediately, it shall be understood that the Contractor will at once begin effecting completion of the action and pursue it to completion in a manner acceptable to the Permit Enforcement Authority, and in accordance with applicable Permitting requirements.

A SWMP consists of the following elements:

- (i) CASDP Narrative Worksheet with Narrative Report. The Narrative Report and supporting documents should fully address the methods to be used to prevent sediment, debris, and other pollutants from entering the MS4 and/ or State Waters in and around the Project area. Proposed structural and non-structural BMPs should be described with sufficient implementation detail to insure that the logical phases of the proposed construction Project meet the performance standards listed in the CASM.
- (ii) Proposed site drawings and Best Management Practice (BMP) installation details as they apply to the site conforming to the Urban Storm Drainage Criteria Manual, Vol. 3, "Best Management Practices", most current version as issued by the Urban Drainage and Flood Control District (UDFCD), or those established by the City's Department of Public Works. If erosion control drawings were included within the bid documents for the Project, they shall be used for bid purposes and initial planning/ deployment of BMPs on the Project. If provided drawings are signed/ sealed by a Professional Engineer, they have been pre-approved by the Permit Authority and may be used without revision for purposes of submitting for CASDP. If provided drawings do not have signature/ seal of Professional Engineer licensed by the State of Colorado, they will require revision by the Contractor with Professional Engineer signature/ seal prior to submission to the City and County of Denver for CASDP.
- (iii) Supporting documentation related to proposed BMPs that are not currently identified in UDFCD Vol. 3 or as otherwise published by the City.

Any preparation of or adjustments to a SWMP must be performed either by or under the supervision of a Professional Engineer licensed in the State of Colorado. SWMP elements submitted to the City shall also meet currently established criteria of the CDPHE as the SWMP must meet all local, State and Federal requirements.

23.0.3 Materials

Materials to be used for BMPs shall conform to each specific detail as set forth within the approved project SWMP or as noted within the Contract Documents.

23.0.4 Erosion Control Permit

The applicable storm water management bid item included within the contract documents will indicate which of the following scenarios applies for the project.

23.0.4.1 Scenario 1: CASDP is not required.

A SWMP is currently not required for this project as the proposed disturbed area and/ or proximity to stream does not meet the minimum criteria for requiring a CASDP. All portions of this specification following this subsection are hereby deleted and shall not be made part of the Project. However, the responsibilities for minimizing sediment pollution from the Project have not been waived, and as such, the City hereby requires the Contractor to perform as specified within this subsection. All costs for performance of the following are included within the associated Storm Water Management bid item included within the contract and shall not be paid for separately.

- a) A CASDP Permit will not be required for this project, however, the Contractor and/or their authorized agents shall ensure that all potential pollutants generated during demolition, excavation, trenching, boring, grading, or other construction Work associated with this permit, be prevented from discharge to stormwater conveyance systems in the vicinity of the Project.
- b) The Contractor shall remove all sediment, mud, construction debris, or other potential pollutants that may have been discharged to or, accumulate in the flow lines of storm drainage appurtenances and public rights of ways of the City and County of Denver as a result of construction activities associated with this Project. All removals shall be conducted in a timely manner.
- c) The Contractor shall be held responsible for remediation of any adverse impacts to the MS4, State Waters, waterways, wetlands, and or other public or private properties, resulting from work done as part of this Project.
- d) The Contractor shall insure that all loads of cut and fill material imported to or exported from the Project shall be properly covered to prevent loss of the material during transport on public rights of way.” (Sec.49-552; Revised Municipal Code)
- e) Approved erosion and sediment control ‘Best Management Practices’ shall be maintained and kept in good repair for the duration of the Project. All necessary maintenance and repair shall be completed immediately upon discovery of any deficiency or defect.

- f) The Contractor shall implement the following Best Management Practices (BMPs) on site during construction:
- i. **VEHICLE TRACKING CONTROL:** This BMP is required at all access points to a construction site that are used by vehicular traffic or construction equipment.
 - ii. **INLET PROTECTION:** This BMP is required on all existing or proposed storm sewer inlets in the vicinity of the construction site that may receive site runoff. The BMP must be appropriate to the type of storm inlet and appropriate for the ground surface at the inlet.
 - iii. **INTERIM SITE STABILIZATION:** This BMP is required to provide a measure for preventing the discharge of sediment from construction sites where overlot grading or other site disturbance has occurred. This BMP is particularly necessary on sites where construction activities/disturbance will be limited to small areas of the project site. Acceptable BMPs include:
 - Preserving existing vegetation
 - Seeding and planting
 - Mulching
 - Mulching and seeding
 - Temporary/Permanent re-vegetation operations
 - Chemical soil stabilizer application (requires Permit Enforcement Authority approval)
 - iv. **WASTE MANAGEMENT/CONTAINMENT:** This BMP requires that all construction wastes, fuels, lubricants, chemical wastes, trash, sanitary wastes, contaminated soils or debris shall be contained on site, protected from contact with precipitation or surface runoff, periodically removed from the construction site, and properly disposed of.
 - v. **SPILL PREVENTION /CONTAINMENT:** This BMP defines the measures proposed for preventing, controlling, or containing spills of fuel, lubricants, or other pollutants; and protecting potential pollutants from contact with precipitation or runoff.
 - vi. **CHUTE WASHOUT CONTAINMENT:** Water used in the cleaning of ready mixed concrete truck delivery chutes shall be discharged into a predefined, bermed containment area on the job site. The required containment area is to be bermed so that wash water is totally contained. Wash water discharged into the containment area shall be allowed to infiltrate or evaporate. Dried concrete waste shall be removed from the containment area and properly disposed of.
 - vii. Should a predefined bermed containment area not be available due to the project size, or lack of an area with a suitable ground surface for establishing a containment area, proper disposal of ready mix washout and rinse off water at the job site shall conform to the approved techniques and practices identified in the Colorado Department of Public Health & Environment’s training video entitled “Building For a Cleaner Environment, Ready Mix Washout Training”, and its accompanying manual entitled, “Ready Mix Washout Guidebook, Vehicle and Equipment Washout at Construction Sites.”

- viii. The direct or indirect discharge of water containing waste concrete to the storm sewer system is prohibited (Sec.56-102a, c; Revised Municipal Code, City and County of Denver).
- ix. Information about, or copies of the video and training manual are available from the Water Quality Control Division, Colorado Department of Public Health & Environment, 4300 Cherry Creek Drive South, Denver, Colorado 80222-1530, (303) 692-3555.
- x. **STREET SWEEPING:** This BMP requires that paved surfaces which are adjacent to construction sites be swept in a timely manner when sediment and other materials are tracked or discharged on to them. Either sweeping by hand or use of street sweepers is acceptable. Street sweepers using water while sweeping is preferred in order to minimize dust. Flushing off paved surfaces with water is prohibited.
- xi. **PERIMETER CONTROL:** This BMP requires that a construction site install a perimeter control measure along the edge of the construction site, to prevent, or filter the discharge of surface runoff from the construction site. The type of perimeter control used shall be determined based on site conditions and location. Maintenance and repair of the control measure shall occur as needed, in a timely manner.
- xii. **STOCK PILES:** Soils that will be stockpiled for more than thirty (30) days shall be protected from wind and water erosion within fourteen (14) days of stockpile construction. Stabilization of stockpiles located within 100 feet of an MS4 or State Waters, or with slopes 3 to 1 or greater shall be completed within seven (7) days following stockpile construction. Stabilization and protection of the stockpile may be accomplished by any of the following: Mulching, Temporary/Permanent Revegetation Operations, Chemical Soil Stabilizer Application (requires Permit Enforcement Authority approval), or erosion control matting/Geotextiles. If stockpiles are located within 100 feet of an MS4 or State Waters, a drainageway or the site perimeter, additional sediment controls shall be required.
- xiii. **SAW CUTTING OPERATIONS:** The Contractor shall protect all storm sewer facilities adjacent to any location where pavement cutting operations involving wheel cutting, saw cutting, or abrasive water jet cutting are to occur. The Contractor shall remove and properly dispose of all waste products generated by said cutting operations on a daily basis or as needed throughout the work day. The discharge of any water contaminated by waste products from cutting operations to the storm sewer system is prohibited. (Sec.56-102a, c; Revised Municipal Code, City and County of Denver).”

23.0.4.2 Scenario 2: CASDP and State Construction Storm Water Permit(s) are required. No SWMP element(s) are included. The City has not provided SWMP elements nor obtained required CASDP or State Construction Stormwater Permit(s) in advance of bid.

SWMP elements have not been included in the Contract Documents. The Contractor shall plan and coordinate with the Permit Authority to prepare all required SWMP elements and obtain

required CASDP. Per CASDP requirements, the Contractor shall obtain the endorsement of a Professional Engineer licensed in the State of Colorado for preparation of the initial SWMP and/ or any proposed Major or Minor SWMP Amendments. This will require the Contractor to provide or retain a Professional Engineer or subcontract with the original Professional Engineer that prepared the Bid Documents.

The Contractor is hereby made aware that the Permit Authority allots up to 3 weeks per review cycle for CASDP Permit applications (2 review cycles are not uncommon).

Per definition, a Major SWMP Modification requires the submission of revised SWMP elements to the Permit Authority for review and approval.

Prior to issuance of a Notice to Proceed, the Contractor shall obtain required State Construction Stormwater Permit(s) as applicable.

23.0.4.3 Scenario 3: CASDP and State Construction Storm Water Permit(s) are required and “For reference only” SWMP erosion control drawings have been provided. The City has not obtained required CASDP or State Construction Stormwater Permit(s) in advance of bid.

The Contractor shall submit a complete SWMP and application to the Permit Authority to obtain the required CASDP. The Contractor shall use the provided “For reference only” erosion control drawings provided in the Contract as a starting point for preparation of required SWMP elements (as required for CASDP) and for general information as to the origin of pay items included in the Bid Documents. The included erosion control drawings have been previously reviewed by the Permit Authority, and the BMPs shown therein have been found to be generally acceptable by the Permit Authority.

It shall be the responsibility of the Contractor to prepare and acquire approval of a complete SWMP and obtain a CASDP from the Permit Authority prior to beginning construction. The Contractor is hereby made aware that the Permit Authority allots up to 3 weeks per review cycle for CASDP applications (2 review cycles are not uncommon).

Per CASDP requirements, the Contractor shall obtain the endorsement of a Professional Engineer licensed in the State of Colorado for preparation of the initial SWMP and/ or any proposed Major or Minor SWMP Amendments. This will require the Contractor to provide or retain a Professional Engineer or subcontract with the original Professional Engineer of the “For reference only” erosion control drawings.

Per definition, a Major SWMP Modification requires the submission of revised SWMP elements to the Permit Authority for review and approval.

Prior to construction, the Contractor shall obtain the required State Construction Stormwater Permit(s) as applicable.

23.0.4.4 Scenario 4: CASDP and State Construction Storm Water Permit(s) are required and completed SWMP has been included. The City has obtained

CASDP in advance of bid. The City has not obtained State Construction Stormwater Permit prior to bid.

An approved SWMP has been prepared and CASDP obtained by the City prior to bidding of the Project and as such must be properly transferred to the Contractor prior to the start of construction. The SWMP has been provided within the Bid Documents and shall be made a part of the Contract. The Contractor shall coordinate with the Construction Project Manager and Permit Authority to perform the necessary transfer of CASDP from City to Contractor prior to the start of construction. The Permit transfer will be performed at no cost to the Contractor.

Prior to transfer of CASDP, additional elements shall be completed by the Contractor before the CASDP will be transferred from City to Contractor:

- a) Complete Sections B&E (Permittee & Site Supervisor) of the CASDP “Narrative Report Information Worksheet”.
- b) Prepare a complete SWMP including any required adjustments for proposed construction phasing, staging areas, or additional items necessary to address applicable project specific Permit requirements. This will require the Contractor to provide or retain a Professional Engineer or subcontract with the original Professional Engineer that prepared the Bid Documents.
- c) Complete the “Construction Scheduling” section of the “Narrative Report Information Worksheet”.
- d) Include specific methods and/or BMPs that the Contractor will implement to address hazardous spill prevention/ containment response.
- e) Provide any “Additional Documentation and Correspondence” applicable to the Contractor as stated in the CASM. This will require the Contractor to provide or retain a Professional Engineer or subcontract with the original Professional Engineer that prepared the Bid Documents.

If deemed necessary, the Contractor may propose modifications to the approved SWMP once the CASDP has been transferred to the Contractor. Per CASDP requirements, the Contractor shall obtain the endorsement of a Professional Engineer licensed in the State of Colorado for any proposed Major or Minor SWMP Amendments. This may require the Contractor to provide or retain a Professional Engineer or subcontract with the original Professional Engineer of the “For reference only” erosion control drawings.

Per definition, a Major SWMP Modification requires the submission of revised SWMP elements to the Permit Authority for review and approval.

Prior to construction, the Contractor shall obtain the required State Construction Stormwater Permit(s) as applicable.

23.0.5 Construction Requirements

23.0.5.1 Construction Implementation

The Contractor shall incorporate into the Project all BMPs as outlined in the accepted Critical Path Method Construction schedule.

23.0.5.2 Alterations to Project BMPs

The Contractor shall design and implement BMPs for correcting potential conditions unforeseen during design of the Project, or as possible for emergency situations, which arise during construction. The Project's SWMP, UDFCD Vol 3 standards and details, and CDOTs "Erosion Control and Storm-Water Quality Guide," and any approved modification to these documents as proposed by the Contractor, shall be used as reference documents for the purpose of designing appropriate BMPs. Measures and methods proposed by the Contractor to deal with unforeseen conditions shall be reviewed and approved in writing by the Permit Enforcement Authority and the Project Construction Engineer prior to implementation and construction.

In an emergency situation, the Contractor shall use best judgment for immediately responding to the emergency situation as it arises.

All costs associated with revising the BMPs utilized throughout the project, for its duration, shall be included within the applicable Storm Water Management bid item. No separate or additional payment shall be made.

23.0.5.3 Permits

The Contractor shall obtain all required permits for the Project including those required by federal, state, and local agencies. The Contractor shall obtain (or transfer from the City when specified) required erosion control and water quality permits and shall be responsible for compliance with all requirements under any such permits.

23.0.5.4 Erosion Control Supervisor

Contractor shall assign to the Project an employee or subcontractor to serve as Erosion Control Supervisor (ECS). The ECS shall be a person other than the Contractor's superintendent, foreman, or equivalent supervisory position. The ECS shall be experienced in aspects of BMP construction and have satisfactorily completed a Colorado DOT or equivalent ECS training program authorized by the City. Proof that this requirement has been met shall be submitted to the City's Construction Project Manager at least ten working days prior to the beginning of any soil disturbance work. A list of authorized ECS training programs is available from the City upon request. Additionally, per definition, the ECS shall be under the direction of a Professional Engineer licensed in the State of Colorado when performing any modifications to the Project Stormwater Management Plan (SWMP).

The ECS shall be responsible for oversight of the implementation, maintenance, and revision of the SWMP for the duration of the Project. The ECS's responsibilities shall be as follows:

- a) Ensure compliance with all water quality permits or certifications in effect during the construction work.
- b) Supervise the installation, construction, and maintenance of all BMPs specified in the Contract and coordinate the construction of BMPs with all other construction operations.
- c) Direct the implementation of suitable BMPs as necessary to correct unforeseen conditions or emergency situations. Direct the dismantling of those

features when their purpose has been fulfilled due to completion of each Project phase unless the Permit Enforcement Authority agrees that the features be left in place.

- d) Inspect the construction site and document inspection activities at least every seven (7) days and immediately following any precipitation or snowmelt event with the potential to cause surface erosion. If no land disturbing construction activities are present during a storm event, post-storm event inspections shall be conducted prior to commencing any new land disturbing construction activities, but no later than seventy-two (72) hours following the storm event.
- e) Attend the preconstruction conference, erosion control preconstruction inspection, Project scheduling meetings, weekly construction/ field meetings, substantial completion and final stabilization inspections, and other meetings regarding construction that could impact water quality.
- f) Evaluate all non-stormwater coming onto the site, such as springs, seeps, and landscape irrigation return flow. If such flow is identified, the ECS shall propose appropriate SWMP modifications to the Contractor to protect off-site water from becoming contaminated with sediment or other pollutants.
- g) Coordinate with the Contractor to implement necessary actions to reduce anticipated or presently existing water quality or erosion problems resulting from construction activities.
- h) Coordinate with the Contractor to ensure all labor, material, and equipment deployed to meet SWMP requirements is judged appropriately.
- i) During construction, update and record the following items in the SWMP as changes occur:
 - i. Construction boundaries (may require Major SWMP Modification)
 - ii. Areas of disturbance (may require Major SWMP Modification)
 - iii. Areas used for storage of construction materials, equipment, soils, or wastes.
 - iv. Location of any dedicated asphalt or concrete batch plants.
 - v. Location of construction offices and staging areas.
 - vi. Location of work access routes during construction.
 - vii. Location of borrow and waste.
 - viii. Location of temporary and permanent stabilization
 - ix. The ECS shall start a new site map before the current one becomes illegible. All site maps shall remain with the SWMP paperwork.
- j) Amend the SWMP whenever there are: additions, deletions, or changes in locations of BMPs. SWMP revisions shall be recorded immediately. Items shall be dated and signed at time of occurrence. Specifically, amendments shall include the following:
 - i. A change in design, construction, operation, or maintenance of the site which would require the implementation of new or revised BMPs; or
 - ii. Changes when the SWMP proves to be ineffective in achieving the general objectives of controlling pollutants in stormwater discharges associated with construction activity.
 - iii. Changes when temporary BMPs are no longer necessary from changes in Project phase and are removed. All inspection and maintenance activities or other repairs shall be documented.

- k) All inspection and maintenance activities or other repairs shall be documented. The SWMP and documentation shall be kept on the Project site at all times.
- l) Modify the site map with arrows to indicate direction of surface and storm water flowing across the Project site.
- m) When adding or revising BMPs in the SWMP, amend the narrative to explain what, when, where, why, and how the BMP is being used, and add a detail to the SWMP.
- n) If using existing topography, vegetation, etc. as a BMP, label it as such in the SWMP site map; amend the Narrative to explain when, why, and how the BMP is being used to the SWMP.
- o) Record on the SWMP, and implement the approved plan for concrete and asphalt saw cutting, grinding, and milling containment and removal.
- p) Update the potential pollutants list in the SWMP throughout construction meeting CASDP requirements.
- q) Spills, leaks, or overflows that result in the discharge of pollutants shall be documented on the inspection form. The ECS shall record the time and date, weather conditions, reasons for spill, and how it was remediated. The ECS shall immediately report to the Contractor and Construction Project Manager the following instances of noncompliance:
 - i. Noncompliance which may endanger health or environment.
 - ii. Spills or discharge of hazardous substance or oil which may cause pollution of the City MS4 or State Waters.
 - iii. Discharge of stormwater which may cause an exceedance of a water quality standard.
- r) Perform a thorough inspection of the stormwater management system at least every seven (7) days and within 24 hours after any precipitation or snowmelt event with the potential to cause surface erosion. The inspection records shall be kept on-site in a written or previously approved format. Inspections shall be conducted during the progress of the work, during work suspensions, or until Final Stabilization of all disturbed areas is approved by Permit Enforcement Authority and shall include the following services at a minimum:
 - i. The construction site perimeter, disturbed areas, and areas used for material storage that are exposed to precipitation shall be inspected for evidence of, or the potential for, pollutants entering the drainage system. BMPs identified in the SWMP shall be observed to ensure that they are operating correctly.
 - ii. The description of potential pollutant sources, and the BMPs identified in the SWMP, shall be revised and modified as appropriate based on the results of the inspection as soon as practicable after such inspection. Modification to the SWMP shall be implemented in a timely manner and in accordance with applicable Permit requirements.
 - iii. The operator shall keep a record of inspections. Uncontrolled releases of sediment or polluted storm water or measurable quantities of sediment found off the site shall be recorded with a brief explanation as to the measures taken to prevent future releases as well as any measures taken to clean up the sediment that has left the site. Inspection records shall be made available to the City upon request. Note: documentation of

uncontrolled releases at site DOES NOT alleviate any State or Federal requirements for reporting of discharges or upset conditions. Care should be taken to ensure compliance with all regulatory requirements at site.

- iv. Seven (7) day inspections are required during construction and at all times until Final Stabilization has been achieved. Seeding and mulching of disturbed areas does NOT count as final stabilization until such time as 70% pre disturbed vegetative cover has been achieved. Sites with growth in place sufficient to deter erosion that have not yet achieved final stabilization may petition the City to grant an alternative inspection schedule while awaiting additional growth for final stabilization. These inspections must be conducted in accordance with the above paragraphs.

23.0.5.5 Applying BMPs

The duration of the exposure of uncompleted construction to the effects of weather shall be as short as practicable. BMPs such as: seeding, surface roughening, mulching, applying tackifier, use of geotextiles and matting, permanent landscaping, or other selected BMPs shall be applied within fourteen (14) calendar days of completion of grading/soil disturbance activities to stabilize the construction site unless disturbed area is within 100 feet of an MS4 or State Waters or has slopes of 3 to 1 or greater in which case BMPs shall be implemented within seven (7) calendar days of completion of grading activities. Disturbed areas where work is temporarily halted shall be temporarily stabilized within seven (7) days after the activity ceased unless work is to be resumed within thirty (30) calendar days after the activity ceased.

Clearing and grubbing operations shall be scheduled and performed to minimize both the area of the Project disturbed at a given time and the amount of time that disturbed areas remain open. BMPs such as temporary seeding are required between successive construction stages when disturbed areas will not be stable or active for thirty (30) calendar days or more. No payment will be made for additional work required because the Contractor has failed to properly coordinate the BMP schedule, thus causing previously stabilized areas to be disturbed by operations that could have been performed prior to the stabilization. Upon failure of the Contractor to coordinate the permanent BMPs with the grading operations in a manner to effectively control erosion and prevent water pollution, the Permit Enforcement Authority can suspend the Contractor's grading operations and the Construction Project Manager can withhold monies due to the Contractor on current estimates until such time that all aspects of the work are coordinated in an acceptable manner.

23.0.5.6 Work Outside Limits of Construction

Non-contiguous areas outside the limits of construction that are used by the Contractor that include, but are not limited to, borrow pits, haul routes, storage and disposal areas, field offices, maintenance, batching areas, etc., shall have appropriate BMPs implemented by the Contractor at the Contractor's expense. Should said areas meet applicable CASDP Permit criteria, the Contractor shall obtain a separate CASDP for each area as applicable at no additional expense to the City.

23.0.5.7 Maintenance

The Contractor shall continuously maintain erosion and sediment control BMPs on a daily basis or as directed by the ECS so that they function properly during and after construction (including work suspensions) until Final Stabilization has been approved by the Permit Enforcement Authority. Maintenance includes, but is not limited to, the following items:

- a) From the time seeding and mulching work begins until the date the Project has reached Substantial Completion of Erosion Control, the Contractor shall keep all seeded areas stabilized at all times. Any damage to seeded areas or to mulch materials shall be promptly repaired.
- b) All inspection sediment removal, and BMP maintenance activities to comply with all Federal, State & Local erosion control permit requirements until Final Stabilization is reached.
- c) All removal and replacement of existing BMPs due to damage to same suffered either by the contractor, outside agencies, the public, or acts of God.
- d) All required mechanical and/ or manual street sweeping.
- e) Discretionary changes required of any regulatory enforcement officer.

If the Contractor fails to maintain the BMPs in accordance with the Contract, or as directed, the City may at the expiration of a period of 48 hours, after having given the Contractor written notice, proceed to maintain BMPs as deemed necessary. The cost thereof will be deducted from any compensation due, or which may become due to the Contractor under this Contract.

23.0.5.8 Minor SWMP Modifications

These shall be made in the field by the Contractor and thoroughly documented in the Contractor's SWMP narrative and drawings. Should the Permit Enforcement Authority deem minor field modifications inadequate, the Contractor may be required to a) make specific modifications as requested by the Permit Enforcement Authority or b) return to the original approved design specifications. Minor SWMP Modifications are allowed, covered under the original CASDP, and required as part of standard maintenance and operation.

23.0.5.9 Major SWMP Modifications

The City reserves the right to require changes in the Work or Project Limits that may require a Major Modification to the SWMP and/ or CASDP due to unforeseen circumstances. Should this occur, the Contractor will be responsible for the following (as applicable):

- a) Make required revisions to comply with changing federal or state rulemaking if occurs within timeframe of Project
- b) Make required revisions due to unforeseen or unplanned conditions leading to deficient Drawings/ SWMP (hazardous materials encountered, landfills, expansion of work limits, etc.)
- c) Prepare revised SWMP elements endorsed by a Professional Engineer licensed in the State of Colorado.

23.0.5.10 Substantial Completion of Erosion Control

When a CASDP is required for the Project, Substantial Completion of the Project as defined by the City and County of Denver General Contract Conditions cannot be reached until Substantial Completion of Erosion Control has been granted. Granting of Substantial

Completion of Erosion Control must be requested by the Contractor and be approved by the Permit Enforcement Authority in the form of a “Certificate of Substantial Completion of Erosion Control”.

23.0.5.11 Final Stabilization

Granting of Final Stabilization must be requested by the Contractor and be approved by the Permit Enforcement Authority. Other permanent soil stabilization techniques may be proposed, in writing, by the Contractor and used upon approval, in writing, by the Construction Project Manager and Permit Enforcement Authority.

The Contractor may reach Final Stabilization via the following procedures:

- a) The Contractor shall file Inactivation Request for Construction Activities Stormwater Discharge Permit (available within CASDP guidance documents) with the Permit Enforcement Authority.
- b) The Contractor shall coordinate with the Permit Enforcement Authority to hold a Final Inactivation Inspection.
- c) If passing, the Permit Enforcement Authority transmits a letter of approval for Final Stabilization.
- d) If not passing, the Permit Enforcement Authority transmits a letter of denial for Final Stabilization with associated inspection report to Contractor.
- e) Stabilization, inspection and maintenance requirements shall continue until confirmation of having met final closure requirements have been granted in writing by the Permit Enforcement Authority. When Final Stabilization has been reached, the Permit Enforcement Authority shall issue a “Certificate of Final Stabilization”.

23.0.5.12 Final Acceptance

CASDP obligations (including reaching Final Stabilization) may hinder the ability to reach Final Acceptance for the overall Project as defined in the City General Contract Conditions.

23.0.6 Construction of BMPs

BMPs shall be constructed so that they conform to all requirements as set forth within the Project SWMP. They shall meet all requirements set forth within each BMP detail and shall be installed and maintained so that they function in an effective and operable manner.

End of Specification



CITY AND COUNTY OF DENVER
ENGINEERING DIVISION

Wastewater Capital Projects Management Standard Construction Specification

25.0 Hot Mix Asphalt Pavement

25.1 Design Intent

These specifications include general requirements applicable to all types of plant mixed hot mix asphalt pavements (HMAP). This work consists of one or more courses of asphalt mixture constructed on a prepared foundation in accordance with specifications. The design intent is to provide pavement with adequate thickness and quality to provide a service life of 20 years. It is also the intent to provide construction in accordance with these specifications and with a high standard of practice. This item shall include all labor, equipment, and materials to manufacture, place and compact asphalt cement concrete for pavement purposes.

TEST PROCEDURE DEFINITIONS	
CP-##	Colorado Department of Transportation: Field Materials Manual (Colorado Testing Procedures)
ASTM	American Society for Testing & Materials
AASHTO	American Association of State Highway & Transportation Officials
CP-L #####	Colorado Department of Transportation: Laboratory Manual of Test Procedures (Lab Testing Procedures)

25.2 Materials

The hot mix asphalt shall be composed of a mixture of aggregate, filler, hydrated lime and asphalt cement. Some mixes may require polymer modified asphalt cement. Some mixes may allow up to 25% reclaimed asphalt pavement (RAP). All RAP shall meet the requirements of section 25.2.5

25.2.1 Aggregate

Aggregates for HMAP shall be of uniform quality, composed of clean, hard, durable particles of crushed stone, crushed gravel, or crushed slag. Excess of fine material shall be wasted

before crushing. The material shall not contain clay balls, vegetable matter, or other deleterious substances and shall meet the requirements in Table 25.2.1.1.

**Table 25.2.1.1
Aggregate Requirements**

Aggregate Test Property	Coarse: Retained on #4	Fine: Passing the #4
Fine Aggregate Angularity, CP-L 5113 Method A or AASHTO T 304 Note: Fine aggregate angularity does not apply to RAP aggregates		45% Min
Two Fractured Faces, CP-45 or ASTM D 5821 SG Mixtures Top and Middle Lifts Bottom Lifts SMA Mixtures	90% Min. 80% Min. 70% Min. 100% required	
LA Abrasion, AASHTO T 96	45% Max.	
Flat and Elongated (Ratio 5:1) %, AASHTO M 283	10% Max.	
Adherent Coating (Dry Sieving) ASTM D 5711	0.5% Max.	
Sand Equivalent. AASHTO-T 176		45% Min.
Micro Deval CP-L 4211 or AASHTO T 327	18% Max	

Reclaimed Asphalt Pavement material (RAP) shall be used only where specifically allowed as shown on the plans and shall be of uniform quality and gradation with a maximum size no greater than the nominal aggregate size of the mix. Mixes shall not contain more than 25 percent RAP.

The HMAP gradation for the proposed design job mix gradation shall be wholly within the control point gradation range set forth in Table 25.2.1.2. The allowable job mix gradation for production shall be the design job mix gradation with the tolerances of Section 25.13.2 applied. The proposed design job mix and the final allowable job mix gradation for production shall report all sieve sizes listed in table 25.2.1.2

Table 25.2.1.2
Dense Graded HMA Gradation Range
(Percent by Weight Passing Square Mesh Sieves, CP-31, AASHTO 11 & T27)

Mixture Grading	SX (1/2" nominal)		S (3/4" nominal)		SG (1" nominal)	
	Control Points	Caution Zone*	Control Points	Caution Zone*	Control Points	Caution Zone*
1 1/2"					100	
1"			100		90-100	
3/4"	100		90-100		@	
1/2"	90-100		@		@	
3/8"	@		@		@	
#4	@		@		@	39.5
#8	28-58	39.1	23-49	34.6	19-45	26.8-30.8
#16	@	25.6-31.6	@	22.3-28.3	@	18.1-24.1
#30	@	19.1-23.1	@	16.7-20.7	@	13.6-17.6
#50	@	15.5	@	13.7	@	11.4
#200**	2.0-8.0		2.0-7.0		1.0-7.0	

* The caution zone is guideline only. It is recommended that mix design gradations go above the caution zone boundaries, on the "fine" side

** These limits shall include the weight of lime at 1.0%

@ These sieve sizes used only to determine the final Allowable Job Mix Formula (JMF) in accordance with 25.13.

25.2.2 Performance Graded Asphalt Binders

The Contractor shall provide to the Construction Project Manager acceptable 'Certifications of Compliance' of each applicable asphalt binder grade from the supplier. Upon non-conformance with specifications, the asphalt binder may be rejected as directed by the Construction Project Manager. When production begins the Contractor shall, upon request, provide to the Construction Project Manager a one quart can of each specified asphalt binder. Additionally, when requested, the Contractor shall provide the refinery test results that pertain to the asphalt binders used during production.

Asphalt binder shall meet the requirements of the Superpave Performance-Graded Binders (PG) as presented in table 25.2.2

TABLE 25.2.2. -PROPERTIES OF PERFORMANCE GRADED BINDERS

Usage for each Binder Grade	PG 58-28	PG 64-22	PG 76-28
Traffic Loading, Total 18 kip ESALs Over Design Life (Usually 20 Years)***	Low Volume (0-100,000)	100,000 to <10.0 Million	3.0 Million to <10 Million
Superpave Compactor Design gyrations Recommended (alternate) Usage	$N_{design} = 50$ (75)	$N_{design} = 75$ (100)	$N_{design} = 100$
Property of Binder Grade	PG 58-28	PG 64-22	PG 76-28
Flash Point Temperature, °C, AASHTO T 48	230 Min.	230 Min.	230 Min.
Viscosity at 135 °C, Pas, ASTM D 4402	3 Max.	3 Max.	3 Max.
Dynamic Shear, Temperature °C, where $C^*/\sin \delta @ 10$ rad/sec. ≥ 1.00 Kpa, AASHTO TP 5	58 ° C	64 ° C	76 ° C
<i>Rolling Thin Film Oven Residue Properties, AASHTO T 240</i>			
Mass Loss, %, AASHTO T 240	1.00 Max.	1.00 Max.	1.00 Max.
Dynamic Shear, Temperature °C, where $G^*/\sin \delta @ 10$ rad/sec. ≥ 2.20 Kpa, AASHTO TP 5	58 ° C	64 ° C	76 ° C
Elastic Recovery ¹ , 25°C, % Min.*	N/A	N/A	50 Min.
TABLE 25.2.2. -PROPERTIES OF PERFORMANCE GRADED BINDERS continued			
<i>Pressure Aging Vessel Residue Properties, Aging Temperature 100 °C AASHTO PPI</i>			
Dynamic Shear, Temperature °C, where $G^*/\sin \delta @ 10$ rad/sec. $\leq 5,000$ Kpa, AASHTO TP 5	19 ° C	25 ° C	28 ° C
Creep Stiffness, @ 60 sec. Test Temperature in °C, AASHTO TP 1	-18 ° C	-12 ° C	-18 ° C
S, Mpa, AASHTO TP 1	300 Max.	300 Max.	300 Max.
m-value, AASHTO TP 1	0.300 Min.	0.300 Min.	0.300 Min.
**Direct Tension Temperature in °C, @ 1.0 mm/min., Where Failure Strain >1.0%, AASHTO TP 3	-18 ° C	-12 ° C	-18 ° C

- * Elastic Recovery by Task Force 31, Appendix B Method
- ** Direct tension measurements are required when needed to show conformance to AASHTO MP.1
- *** Project Design Engineer is to determine PG Binder

25.2.3 Additives – Hydrated Lime

Lime shall be added at the rate of 1% by dry weight of the aggregate and shall be included in the amount of material passing the No. 200 sieve. Hydrated lime for aggregate pretreatment shall conform to the requirements of ASTM C 207, Type N. In addition, the residue retained on a 200-mesh sieve shall not exceed 10% when determined in accordance with ASTM C 110. Drying of the residue in an atmosphere free from carbon dioxide will not be required.

25.2.4 Tack Coat

The emulsified asphalt, for Tack Coat shall be CSS-1h or SS-1h and conform to AASHTO M208 or M140, respectively.

25.2.5 Reclaimed Asphalt Pavement

Reclaimed Asphalt Pavement (RAP) may be allowed in the HMA mixture by the **Project Design Engineer**. It shall be of uniform quality and gradation with a maximum size particle no greater than the maximum size allowed in the HMA mixture. HMA mixtures containing RAP shall meet the same gradation requirements as a virgin HMA mix. The Project Design Engineer may allow mixtures with a maximum of 20% RAP may be allowed in the top lift of any asphalt pavement, and a maximum of 25% RAP may be allowed in layers below the top lift, RAP is not allowed in Stone Mastic Asphalt Mixtures, except by agreement by the **Project Design Engineer**.

The reclaimed asphalt pavement shall meet all the requirements for HMA pavement, as contained herein. The **General Contractor** shall have an approved mix design for the amount of RAP to be used prior to placement.

The **Construction Project Manager** may require the **General Contractor** to maintain separate stockpiles for each type of RAP material. All processed material shall be free of foreign materials and segregation shall be minimized. Any RAP material that cannot be readily broken down in the mixing process, and/or affects the paving operation, shall be processed prior to mixing with the virgin material.

Fine Aggregate Angularity requirements shall not apply to any RAP aggregate. The RAP will not contain clay balls, vegetable matter, or other deleterious substances.

Verification testing for asphalt content and gradation will be performed on RAP at the frequencies listed in section 25.5.2, below. The **Construction Project Manager** may request the mix supplier's testing results on RAP at any time. In addition, the mixture shall be tested for properties as listed in Table 25.15

When the use RAP is allowed, the following additional conditions shall apply:

25.2.5.1. The processed RAP must be 100 percent passing the 1¼” sieve. The aggregate obtained from the processed RAP shall be 100% passing the 1” sieve. The aggregate and binder obtained from the processed RAP shall be uniform in all the measured parameters in accordance with the following schedule:

Table 25.2.5.1 RAP AGGREGATE UNIFORMITY TOLERANCES

<u>Element</u>	<u>Uniformity*</u>
Binder Content	0.5
% Passing ¾”	4.0
% Passing ½”	4.0
% Passing 3/8”	4.0
% Passing #4	4.0
% Passing #8	4.0
% Passing #30	3.0
% Passing #200	1.5

* Uniformity is the Maximum allowable Standard Deviation of test results of processed RAP.

25.2.5.2. The **General Contractor** shall have an **approved RAP Quality Control (QC) Plan** that details how the RAP will be processed and controlled. The QC plan must address the following:

25.2.5.2. A. RAP Processing Techniques. This requires a schematic diagram and narrative that explains the processing (crushing, screening, and rejecting) and stockpile operation for normal plant operation or a specific project.

25.2.5.2. B. Control of RAP Asphalt Binder Content: - Minimum Testing Frequency: 1/1,000 tons of processed RAP material (minimum 3 tests) for recent production of the mix type.

25.2.5.2. C. Control of RAP Gradation (CP31 or AASHTO T-30): Minimum Testing Frequency: 1/1,000 tons of processed RAP material (minimum 3 tests) for recent production of the mix type.

25.2.5.2. D. Process Control Charts shall be maintained for binder content and each screen listed, during addition of any RAP material to the stockpile. The **General Contractor** shall maintain separate control charts for each RAP stockpile. The control charts shall be displayed and shall be made available to the **Construction Project Manager** upon request.

25.2.5.3 Example of RAP QUALITY CONTROL PLAN

25.2.5.3. A Initial quality control of the reclaimed asphalt pavement shall be performed prior to and during crushing. Material for reclamation shall be separated by quality and source before being accepted for processing. Reclaimed asphalt must be free of concrete, dirt and organic materials... These stockpiles shall be built from the ground up, completely mixing all loads as they come in.

25.2.5.3. B Crushing of the reclaimed asphalt pavement shall be accomplished by means of a cone crusher and a screen deck. Oversize material shall be to be rejected on a ¾" scalping material, which reprocesses the material through the cone additional times. The processed material shall be stockpiled at the crushing facility and kept in separate piles and separate from other products to prevent intermingling of products, as well as the feed bins to prevent intermingling of the aggregates.

25.2.5.3. C The reclaimed asphalt pavement material shall be sampled during the crushing operations according to AASHTO T 2 at frequencies greater than 1/1000 tons and tested for gradation and asphalt content in accordance with AASHTO T 27 AND T11, and AASHTO T 308. Testing shall be done randomly on a daily basis to ensure conformance to specifications.

25.2.5.3. D The reclaimed asphalt pavement material at the asphalt plant shall be again sampled and tested according to the appropriate procedures to ensure that the asphalt content and gradation meet specifications and represent initial quality control data. Once data is collected, a statistical analysis shall be performed to determine the blend for the asphalt mixture design. This analysis shall be provided with the Asphalt Mixture Design submittal. The RAP will meet the Uniformity Specification of Table 25.2.5.1 above.

25.2.5.3. E The RAP system at the asphalt plant consists of a feed bin with a variable speed motor controlled by the plant computer, which ensures the proper quantity of RAP material called for by the mix design. Material is delivered to the asphalt-mixing chamber of the asphalt plant by means of conveyor belts. The RAP material falls from one conveyor to another through a shaker screen that serves to break up any RAP material that has recompacted. Any oversize material shall be rejected at the shaker screen. While in production, the front-end loader shall works the full face of the stockpile, to ensure a representative batch is being produced.

25.2.5.3. F Prior to starting a project and at any other time necessary, the RAP feed system shall be calibrated by placing an amount of RAP measured by certified external scales into the feed bin. That measured material is fed from the RAP bin across the belt scales. The weights are compared and, if outside of accepted tolerances for the blending system, adjustments are made by the plant-blending computer. This process is the same as for all other components of the mix design.

25.3 Mix Design and Plant Produced Mixture Requirements

The mix design materials shall be those listed in Section 25.2 and used for the project. No substitutions are allowed during production, unless approved by the **Construction Project Manager**.

The **Project Design Engineer** shall indicate on MGPEC Form #9 the project specific criteria concerning mix design method, traffic level, asphalt binder type, mixture grading, and maximum amount of RAP allowed. This information shall be provided on MGPEC Form #9, "Requirements for Hot Mix Asphalt (HMA)", or other Contract bidding documents. Grading SG (1-inch nominal aggregate) shall only be designed using the 150 mm Superpave molds. Hveem Stability and Lottman test are not required for Grading SG mixtures. Grading S and SX shall be designed using 100 mm Superpave molds.

25.3.1 Superpave Mixture Design Method

The **General Contractor** shall submit a Proposed Design Job Mix Formula (PDJMF) for each mixture required by the Contract. The mixture design shall be determined using AASHTO T-312 or Colorado Procedure CP-L 5115 for the Superpave Method of Mixture Design. Guidance is provided in "Superpave Level 1 Mix Design" SP-2 published by the Asphalt Institute. Mixture design and field control testing shall meet the following requirements of Table 25.3.1a (located on the following page) for Dense Graded HMA.

Mixture design and field control testing of SMA shall meet the following requirements of Table 25.3.1b.

This area is a large blank space inserted for the purpose of keeping the table whole

TABLE 25.3.1a SUPERPAVE MIXTURE PROPERTIES FOR DENSE GRADED HMA

Property or Test	Traffic Levels (ESALs)		
Traffic Loading, Total 18 kip ESALs Over Design Life (Usually 20 Years)	Low (0-100,000)	Medium (100,000 to <3.0 Million)	High (3.0 Million to <30 Million)
Design gyrations, N_{design} (Air Void: 3.5% to 4.5%) (See Note 1,2)	50	75	100
Air Voids in Total Mix (VTM) CPL 5115 or AASHTO T 312	(See Note 1)	(See Note 1)	(See Note 1)
Hveem Stability CP-L 5106 or AASHTO T 246 (Grading S & SX only) (See Note 3)	N/A	28 Min.	30 Min.
Voids Filled with Asphalt (VFA), MS-2	70-80	65-78	65-75
Lottman, Tensile Strength Ratio, % Retained, CP-L 5109 or AASHTO T 283, Method B	80 Min.	80 Min.	80 Min.
Lottman, CP-L 5109 or AASHTO T 283 Dry Tensile Strength, psi	30 Min.	30 Min.	30 Min.
VMA %. CP-48 or AASHTO PP 19 (See notes 2,3,4)	Minimum VMA criteria applies to the mix design only (Table 25.2.1.2). The minimum VMA criteria shall be linearly interpolated based on actual air voids. See 25.13 for production tolerances		

Note 1: Select the target Job Mix Optimum Binder Content for HMA gradings as close to 4.0% air voids as possible (3.5% to 4.5% air voids).

VTM is also referred to as Pax in CPL 5115, and %Gmmx in T 312

Note 2: Maximum Theoretical Specific Gravity of mix by CP-51 or AASHTO T 209.

Note 3: Refer to Section 25.13 for production tolerances.

Note 4: VMA shall be based on tests of the Bulk Specific Gravity of the Compacted Mix (CP-L 5103 or AASHTO T 166) and Aggregate (AASHTO T 84 & T 85), and calculated according to CP-48 or AASHTO PP 19. All mixes shall meet the minimum VMA specified in Table 25.3.2, below.

Table 25.3.1b SUPERPAVE MIXTURE PROPERTIES FOR OPEN GRADED SMA

Property	Test Method	Value for SMA
Lab compaction (Revolutions) N_{Design}	CPL 5115 or AASHTO T 312	100
Air Voids, percent at: N_{Design} (See Note 1)	AASHTO T 312	3.0 – 4.0
Hveem Stability	CP-L 5106 or AASHTO T 246	30 Min.
Accelerated Moisture Susceptibility, tensile strength Ratio, (Lottman)	CPL 5109 or AASHTO T 283, Method B	80 Min.
Dry Split Tensile Strength, psi	CPL 5109 or AASHTO T 283, Method B	30 Min.
Grade of Asphalt Binder	n/a	PG 76-28
Voids in the Mineral Aggregate (VMA) %, minimum (see note 2)	CP 48 or AASHTO PP 19	17
Draindown at Production Temperature	AASHTO T 305	0.3 maximum
% VCA_{MIX} (See Note 3)	AASHTO PP 41-02	Less than VCA_{DRC} (See Note 4)

General Note: Copies of AASHTO PP 41-02 and MP 8-02 (for designing SMA mixes) can be obtained from the CDOT Region Materials or the Project Design Engineer

Note 1: Select the target Job Mix Optimum Binder Content for SMA grading at 3.0% to 4.0% air voids

Note 2: VMA shall be based on tests of the Bulk Specific Gravity of the Compacted Mix (CP-L 5103 or AASHTO T-166) and Aggregate (AASHTO T 84 & T 85), and calculated according to CP-48 or AASHTO PP 19. All mixes shall meet the minimum VMA specified in Table 25.3.2, below

Note 3: VCA = Voids in the Coarse Aggregate

Note 4: DRC = Dry-Rodded Condition

**TABLE 25.3.2 MINIMUM VOIDS IN MINERAL AGGREGATE (VMA) for
Dense Graded HMA & Open Graded SMA, %**

Nominal Maximum* Particle Size	Air Voids ++		
	3.5%	4.0%	4.5%
1"	12.2	12.7	13.2
¾"	13.2	13.7	14.2
½"	14.2	14.7	15.2
SMA	17.0	17.0	17.0

* Nominal Maximum Particle Size is defined as one sieve size larger than the first sieve to retain more than 10%, but shall not exceed the 100% passing size. The Nominal Maximum Particle Size can vary during mix production even when the 100% passing size is constant.

++ Minimum VMA criteria apply to the mix design only. The minimum VMA criteria shall be linearly interpolated based on actual air voids. See Section 25.13 for tolerances.

25.4 Mixture Design Submittals

25.4.1 General Requirements

The General Contractor shall submit all mixture designs, certificates, refinery reports, and laboratory data to the Construction Project Manager for approval at least 7 days before construction is to begin. The job mix formula may be rejected as directed by the Construction Project Manager on the basis of incompleteness, timeliness or changes in materials. Submittals shall be in a timely fashion such that rejection will not delay completion of the project.

Proposed Design Job Mix testing shall be performed in a materials laboratory under the direct supervision of; and shall be stamped and signed by a Professional Engineer licensed in the State of Colorado practicing in this field. In addition, the General Contractor shall submit as part of the Proposed Design Job Mix, documents to verify the following:

1. Source of materials.
2. Gradation, specific gravity, source and description of individual aggregates and the final blend.
3. Aggregate physical properties.
4. Source and Grade of the Performance Graded Binder (PG Binder)
5. Proposed Design Job Mix – aggregate and additive blending, final gradation shown on 0.45 power graph, optimum asphalt content.
6. Mixing and compaction temperatures used.

7. Mixture properties determined at a minimum of four asphalt contents and interpolated at optimum and graphs showing mixture properties versus asphalt content.

The Construction Project Manager reserves the right to test the General Contractor’s mix for each hot asphalt pavement grading utilizing materials actually produced and stockpiled. General Contractor shall provide a sufficient quantity of each aggregate, mineral filler, RAP, and additive for the required laboratory tests, if required by the Construction Project Manager.

The Contractor shall not place any materials without acceptance and approval of the Construction Project Manager.

25.4.2 Change in source or grade

Should a change in the source of Asphalt Cement (AC) or Lime occur, a one point verification test (at optimum asphalt content) of the mix must be performed to verify that the applicable Table 25.3.1a(Dense Graded HMA) or 25.3.1b (SMA) or 25.3.2 (VMA), is still met. If this testing shows noncompliance, a new design job mix shall be established before the new AC or Lime source is used. Any change in aggregate type or source will require a new mix design.

25.4.3 Mix Production Verification

Production verification shall occur prior to the start of the project. The production verification shall be performed by LABCAT Level C certified technicians with current Certification to verify the volumetric properties of the mix. If the mix has been produced for another project within the last 90 days, data from that project can be submitted for this verification. Volumetric properties of the mix verification testing shall be within the following tolerances compared to the Proposed Design Job Mix. The mix verification test reports shall be submitted to the Construction Project Manager prior to mix placement.

TABLE 25.4.3.1 MIX DESIGN VERIFICATION TOLERANCES

Air Voids	+/- 1.2%
VMA	+/- 1.2%
Asphalt Binder Content	+/-0.3%
Stability	Applicable minimum

The tolerances in this table are for mix design verification only. See section 25.13 for production tolerances.

25.4.4 Pre-paving Meeting

The Construction Project Manager may require a pre-paving meeting of all parties involved in supply, haul, laydown inspection, quality control and quality acceptance of HMA. Areas of responsibility and contact names and numbers should be shared. A construction (joint) plan will be submitted at the pre-paving meeting, see section 25.9 for joint requirements. Form 25.1 provided at the end of this specification is an example of a pre-paving meeting

agenda.

25.5 Equipment

25.5.1 Mixing Plant

The mixing plant shall be capable of producing a uniform material, have adequate capacity, and be maintained in good mechanical condition. Defective parts shall be replaced or repaired immediately if they adversely affect the proper functioning of the plant or plant units, or adversely affect the quality of the hot bituminous plant mix.

Dust, smoke, or other contaminants shall be controlled at the plant site to meet all air quality requirements in the “Colorado Air Quality Control Act,” Title 25, Article 7, CRS and regulations promulgated there under.

Acceptable safety equipment, approved by the Construction Project Manager, shall be provided by the General Contractor to accommodate sampling and testing.

25.5.2 Hauling Equipment

Trucks used for hauling HMAP shall have tight, clean, smooth metal beds thinly coated with a minimum amount of paraffin oil, lime solution, or other approved release agent. Petroleum distillates such as kerosene or fuel oil will not be permitted. Each truck shall have and use a cover of canvas or other suitable material to protect the mixture from the weather and excessive temperature loss or cooled layers of mix in truck.

25.5.3 Bituminous Pavers

Self-propelled pavers shall be provided for full lane width paving capable of spreading and finishing the HMA, material in full lane widths applicable to the typical section and thicknesses shown in the Contract and shall be equipped with:

1. anti-segregation devices,
2. A vibratory screed assembly capable of being heated.

Pavers used for shoulders, patching and similar construction, not requiring fine grade control, shall be capable of spreading and finishing courses of HMA material in widths shown in the Contract without segregation.

The paver’s receiving hopper shall have sufficient capacity for a uniform spreading operation and shall have an automatic distribution system that will place and spread the mixture uniformly in front of the screed.

The paver shall be capable of operating at forward speeds consistent with uniform and continuous laying of the mixture. Stop and go operations of the paver shall be avoided. The screed or strike-off assembly shall produce the specified finished surface without tearing, shoving, or gouging the mixture. Self-propelled pavers shall be equipped with automatic screed controls with sensors capable of sensing grade from an outside reference line, and maintaining the screed at the specified longitudinal grade and transverse slope. The sensors may be contact or non-contact type devices. The sensor shall be constructed to operate from either or both sides of the paver and shall be capable of working with the following devices when they are required for the situation:

1. Grade control device at least 30 feet in length.
2. Joint matching device
3. Adequate length of control line and stakes, if no other type of geometric control is present
4. A straight edge at least 10 feet in length will be available to verify the crown on the screed, at the request of the Construction Project Manager

The controls shall be capable of maintaining the screed at the specified transverse slope within plus or minus 0.1 percent. Automatic mode should be used where possible. If the automatic controls fail or malfunction, the equipment may be operated manually for the remainder of the normal working day, provided specified results are obtained.

If the Contractor fails to obtain and maintain the specified surface tolerances, the paving operations shall be suspended until satisfactory corrections, repairs, or equipment replacements are made. Placement of HMA on a waterproofed bridge deck shall be accomplished with equipment that will not damage the membrane or protective covering.

25.6 Manufacture

25.6.1 Preparation of Aggregates

Heating and drying of the aggregates shall be accomplished without damaging the aggregate. Lime shall be added to achieve complete and uniform coating of the aggregate. When hydrated lime is used it shall be added to the aggregate in accordance with one of the following methods:

- a. Lime Slurry Added to Aggregate: The hydrated lime shall be added to the aggregate in the form of a slurry and then thoroughly mixed in an approved pugmill. The slurry shall contain a minimum of 70 percent water by weight.
- b. Dry Lime Added to Wet Aggregate: The dry hydrated lime shall be added to wet aggregate (a minimum of three percent above saturated surface dry) and then thoroughly mixed in an approved pugmill.

The lime-aggregate mixture may be fed directly into the hot plant after mixing or it may be stockpiled for not more than 90 days before introduction into the plant for mixing with the asphalt cement. The hydrated lime may be added to different sized aggregates and stockpiled, by adding 75 percent of the lime to the aggregate passing the No. 4 sieve and 25 percent to the aggregate retained on the No. 4 sieve.

25.6.2 Mixing

The dried aggregates and asphalt cement shall be combined in the mixer in the quantities required to meet the design job mix. The materials shall be mixed until the aggregate is

completely and uniformly coated, and the asphalt cement is uniformly distributed throughout the aggregate. The output rate shall not exceed the manufacturer's capacity rating.

Baghouse fines shall be fed to the mixing plant in a uniform and continuous manner so as to maintain uniformity in the mixture. The Baghouse, fines feeder, auger, and related equipment, shall be in good working condition and operated in accordance with manufacturer's recommendation. If the Construction Project Manager determines that non-uniform operation of the equipment is detrimental to the mixture, he may halt all construction until the General Contractor takes appropriate action.

The minimum temperature of the mixture when discharged from the mixer shall be as shown in the following table:

**Table 25.6.2.1
Mixture Discharge Temperatures**

Asphalt Grade	Minimum Discharge Temperature	Maximum Discharge Temperature
PG 58-28	275° F	310° F
PG 64-22	290° F	325° F
PG 76-28*	318° F	326° F

* Contractor or Binder supplier must supply production temperature as require by their product

The General Contractor may provide refinery information that recommends revised discharge temperatures depending on the base binder grade or source being used. HMA mix shall be produced at the lowest temperature within the specified temperature range that produces a workable mix and provides for uniform coating of aggregates (95 percent minimum in accordance with AASHTO T 195), and that allows the required compaction to be achieved.

HMA mix may be stored provided that any and all characteristics of the mixture are not altered by such storage. If storing or holding of the mixture causes segregation, excessive heat loss, or adversely affects the quality of the finished product, corrective action shall be taken. Unsuitable mixture shall be disposed of at the **General Contractor's** expense.

When placing hot mix asphalt over bridge decks covered by waterproofing membrane, the minimum temperature of the mixture, when rolling operations begin, shall be 250 ° F. The job mix temperature may be increased up to 30 ° F to obtain this temperature.

The mineral filler for SMA shall be stored in a separate silo and added automatically in the correct proportion. The mineral filler addition equipment shall be electronically or mechanically interlocked to the aggregate feed sensors so that the proper amount of mineral filler is added whenever SMA is produced.

The SMA mineral filler shall be added at the same point the asphalt binder is added to the aggregate.

25.6.3 Hauling

Each truck shall use covers (tarps) to protect the mix during transport. The Construction Project Manager can reject mix, which is hauled without a cover. Should the mixture show an excess or deficiency of asphalt cement, damage due to burning or overheating, an improper gradation, or thermal segregation with cold areas 10° F below the minimum discharge temperature, the truck shall be rejected.

25.7 Tack Coat

Prior to placement of HMA, a tack coat shall be applied. The material shall be in accordance with 25.2.4. The emulsified asphalt shall be diluted 1:1 with water and applied at 0.10 ± 0.01 gallons per square yard of diluted material. The Construction Project Manager may direct other application rates to match the age of condition of the surface.

All work shall be done at locations and with the grade and quantities of material designated on the plans. The surface to receive the tack coat shall be dry and cleaned by sweeping or other approved method until dust, debris, and foreign matter are removed. The tack coat shall then be applied uniformly by squeegee, brooms, or distributor. Prior to placement of SMA, tack coat between the existing pavement and Stone Matrix Asphalt pavement shall be placed at a rate between 0.03 and 0.05 gallons per square yard

25.8 Placement

Hot mix asphalt shall be placed only on approved, properly constructed surfaces that are free from loose material, water, frost, snow or ice. The hot mix asphalt and tack coat shall be placed in accordance with the temperature limitations of Table 25.8 and only when weather conditions permit the pavement to be properly placed and finished as determined by the Construction Project Manager. Placement temperature as stated shall be increased by 5° F for each 10 miles per hour wind velocity to a maximum increased minimum placement temperature of 70° F.

**Table 25.8
Placement Air and Surface Temperature Limitations**

Compacted Layer Thickness	Top Layer of Pavement*		Lower Layers*	
	PG 58-28 PG 64-22	PG 76-28	PG 58-28 PG 64-22	PG 76-28
<2 inches not permitted	N/A	N/A	N/A	N/A
2 inches to <3 inches	50° F	65° F	40° F	50° F
3 inches or more	50° F	60° F	40° F	40° F
SG mix only	N/A	N/A	38° F	38° F

* Air temperature is taken in the shade. Surface temperature is taken on the subgrade or base. The Construction Project Manager may not waive the above temperature limitations for PG 76-28.

The mixture shall not be placed at a temperature lower than 245° F for mixes containing PG 58-28 or PG 64-22 asphalt, and 290° F for mixes containing polymer modified asphalt. Mix, which is too cold or damaged by weather, will be rejected.

The mixture shall be laid upon an approved surface, spread and struck off to obtain the required grade and elevation after compaction. The minimum lift thickness shall be **at least three times (preferably four times)** the normal particle size. The mixture shall be placed approximately 10-25 percent thicker than the existing surrounding mat thickness to account for compaction based on the materials being placed. Raking is not permitted and will not be allowed. Casting that causes any segregation will not be permitted.

On areas where the use of mechanical spreading and finishing equipment is impracticable, the mixture shall be carefully dumped, spread, raked, screeded, and luted by hand tools to the required compacted thickness plus 25 percent based on the materials being placed.. Carefully move or minimally work the HMA mix with the use of rakes, lutes, or shovels to avoid segregation. Mixtures made with modified asphalt cement require more rapid completion of handwork areas than for normal mixtures. Hauling and placement sequences shall be coordinated so that the paver is in constant motion. Starting and stopping shall not be allowed. A construction joint shall be placed at anytime the power stops, and the screed drops enough to cause a surface dip in violation of Section 25.13.1, “Surface Tolerances”; or the mat temperature falls below that allowed in Section 25.12, “Compaction”. Bituminous pavers shall be used to distribute the mixture either over the entire width or over such partial width as may be practicable. Echelon paving will be permitted.

If an unsatisfactory mix has been placed, it shall be removed, disposed of and replaced as directed. No compensation will be allowed for rejected material.

25.8.1 SMA PLACEMENT & Compaction

A Roller Pass Study (RPS) for Density and 1000 foot demonstration control strip are required for placement of lifts less than or equal to 1.5 inch thick, optional for thicker lifts.

25.8.1.A For Thin Lift SMA less than or equal to 1.5 inch thick.

In-place density shall be determined through the completion of a Roller Pass Study (RPS) to be conducted during placement of the required 1000-foot demonstration control strip. The RPS will determine the necessary roller compaction process needed to produce a minimum pavement density of 94 percent of theoretical maximum density (RICE). During the RPS, a minimum of three sets of three 4-inch diameter cores each shall be taken to measure SMA mat density for the various sections of the RPS. All coring shall be completed by the **General Contractor** and submitted to the **Construction Project Manager**. The densities of the three cores will be averaged to produce the density for each RPS section tested.

Full production of the thin SMA shall not begin until density test results are determined and the project compaction process is established by the **General Contractor** and approved by the **Construction Project Manager**. The approved compaction process established from the RPS shall be used for the duration of the thin SMA paving. Changes to the thin SMA mixture will be reviewed and a new RPS may be required.

Using the same method for determining density during the RPS, density will be determined

daily for each day of full production and tested to confirm pavement density. If a daily density check shows density below 92 percent of RICE, the **General Contractor** shall stop production and the **General Contractor** will again complete a RPS to establish the necessary compaction process. The **General Contractor** will be allowed two daily density checks below 92 percent of RICE to be addressed in this manner during the project. All subsequent daily checks that identify locations having density below 92 percent of RICE shall be removed and replaced and a new RPS shall be completed and approved prior to again beginning production. Thin SMA density requirements will be enforced when the SMA mix design gradation and specified lift thickness are in accordance with or exceed the 3:1 requirements for the ratio of nominal maximum aggregate size to lift thickness.

The **General Contractor** shall submit a plan for a Roller Pass Study (RPS) to the **Construction Project Manager** for approval. Upon approval by the **Construction Project Manager**, the **General Contractor** shall perform a RPS. The plan for the RPS shall include, but is not limited to the following:

- Number, size, and type of rollers.
- Amplitude, frequency, size and speed of vibratory rollers.
- Temperature of mixture being compacted.
- Roller patterns.

The method of measuring density will be by roller passes. If a density element is based on a RPS, the Pay Factor shall be as shown in section 25.14.3.

25.8.1.B For SMA lifts greater than 1.5 inch thick.

If in the opinion of the **Construction Project Manager**, the roller pass study presented by the **General Contractor** is inadequate, then the **General Contractor** shall modify the compaction procedures as directed.

25.8.1.C Before Proceeding with SMA placement,

The General Contractor shall demonstrate the ability to produce and place a satisfactory mix. The actual work may proceed when a full lane width demonstration control strip, having a minimum length of 1000 feet has been successfully placed. The **GENERAL CONTRACTOR** shall determine properties (Superpave Air voids, VMA, in-place density, and Hveem Stability) of the project produced mix that is used in the demonstration control strip and provide the results to the **Construction Project Manager**. No other SMA production or placement will be allowed until densities are determined. If the material in the demonstration control strip is not in close conformity with the specifications, the demonstration control strip will be removed and replaced at the **General Contractor's** expense. The **Construction Project Manager** will designate the location of the control strip.

SMA mixture shall be transported and placed on the roadway without drain-down or flushing. All flushed areas behind the paver shall be removed immediately upon discovery. If more than 50 square feet of flushed SMA pavement is ordered removed and replaced in any continuous 500 linear feet of paver width laydown, operations shall be discontinued until the source of the flushing has been found and corrected. The **Construction Project Manager** will designate the depth and area of all flushed areas requiring removal and replacement. All costs associated with the removal and replacement of the flushed areas shall be at the **General Contractor's** expense.

Stone Matrix Asphalt Pavement shall be placed and compacted in accordance with the temperatures listed in table 25.8 or as revised for the project.

The relative compaction for all SMA mixtures will be measured from roadway cores in accordance with CDOT-CP 44 or AASHTO T-166, Method B, unless the SMA mixture is being placed on a structure (bridge deck) in which case the **Construction Project Manager** may specify that nuclear gauge measurements be used.

When cores are used, the **General Contractor** shall provide all labor and equipment for the coring operation and filling the core holes. When nuclear density gauges are used, the tests will be performed in accordance with CDOT-CP 81 or ASTM D 2950 and CDOT-CP 82 or AASHTO T 230.

In-place density for SMA shall be 95 ± 2 percent of the SMA Mix maximum specific gravity as measured according to Maximum theoretical value (Rice) (CDOT-CP 51 or AASHTO T 209).

25.9 Longitudinal Joints

25.9.1 Joint Placement

The longitudinal joints in both a new pavement and an overlay pavement layer shall offset the joint in the layer immediately below by 6 inches. The joints in any pavement layer shall not fall in a wheel track. The joints in the top layer of new pavement not built on top of an existing pavement shall be located on lane lines or as shown on the plans. Longitudinal joints shall be minimized, where feasible, with wide paving pulls or echelon paving. Joints shall be parallel to the flow of traffic and shall not cross any centerline, lane line, or edge line unless approved by the **Construction Project Manager**. The **General Contractor** shall submit, prior to paving, a joint plan and pavement marking plan showing locations and the methods to establish a field control line. The **Construction Project Manager** must approve such plans prior to paving. The **General Contractor** shall use a continuous string line to delineate longitudinal joints during paving as shown on the joint plan. All string lines shall be removed at the end of each day's paving.

The free edge of the paved pass shall be laid as straight as possible, to the satisfaction of the **Construction Project Manager**. This joint, if cold, shall be tack coated prior to placement of adjacent paving.

The new compacted mat shall overlap the previously placed mat no more than 1.5 inches. Excess overlap or thickness shall not be raked or cast onto the new mat, but shall be wasted by pulling back and removing. The hot edge shall be blocked or bumped in a smooth line consistent with the previous longitudinal edge. Minor raking will only be allowed to correct major grade problems or provide mix around manholes and meter covers. The longitudinal joint shall be rolled from the hot side and overlap the joint by approximately 6 inches on the cold side.

25.10 Transverse Joints

The **General Contractor** shall submit, prior to paving, a joint plan showing locations and the methods to be used to construct transverse joints. The **Construction Project Manager** must approve such plans prior to paving. Placing of the HMA shall be continuous with a minimum of transverse joints, and rollers shall not pass over the unprotected end of a freshly laid mixture. Transverse joints

shall be formed by cutting back on the previous run to expose the full depth of the course. Tack coat material shall be applied to contact surfaces of all joints just before additional mixture is placed against the previously compacted material.

The end of transverse joints shall be located so they will be constructed with a full head of mix in front of the screed. When butt joints are constructed, runoff boards shall be used to support the roller on the downstream side of the joint. All tapered sections, rounded edges and segregated areas shall be removed to achieve a vertical face at the butt joint before paving is restarted.

When a temporary tapered joint is required for temporary traffic access, the ramp shall be removed back to a full depth section before paving is restarted.

When restarting paving operations, the paver screed shall be placed on the starter block on the completed side of the transverse joint. The starter block should be approximately 25% greater than the thickness of the existing completed mat, so that adequate grade and compaction can be achieved on starting the paving operation. The screed should be nulled (angle removed) when on starting blocks and an up angle of attack set. Proper head of mix should be introduced into the paver prior to starting. The new compacted (downstream) side of the joint may be up to 3/16 inches higher than the old (upstream) side. Raking of this joint shall not be allowed except to correct major grade problems. The surface tolerance at the transverse joint must be verified by the **General Contractor** with a 10-foot straight edge before the paver is more than 100 feet from the joint. If the surface tolerance is not within the 3/16", the **General Contractor** shall make corrections before proceeding

25.11 Segregation

The asphalt mixture shall be transported and placed on the roadway without segregation. All segregated areas shall be removed immediately and replaced with specification material before the initial rolling. If more than 50 square feet of segregated pavement is removed and replaced in any continuous 500 linear feet of paver width laydown, operations shall be discontinued until the source of the segregation has been determined and corrected.

The Construction Project Manager will visually determine areas, which are segregated, and may also use density and gradation measures to help in this determination. The Construction Project Manager will visually determine the extent of the segregation. The General Contractor will not be allowed additional compensation for correction of segregated areas.

25.12 Compaction

The temperature of the mixture immediately behind the screed shall be sufficient to allow for proper compaction of the HMA layer and at least 245 °F for PG 58-28 or PG 64-22 binder and between 297°F and 305 °F for PG 76-28 binder. The breakdown compaction should be completed as quickly as possible after placement occurs.

The HMA shall be compacted by rolling. The number, weight, and type of rollers furnished shall be sufficient to obtain the required density and surface texture while the mixture is in a workable condition. Compaction shall begin immediately after the mixture is placed and be continued until the required density is obtained. Final compaction shall be obtained using steel wheel rollers.

Pavement operations shall be suspended when density requirements are not met and the surface

temperature falls below 185 °F, or there is obvious surface distress or breakage, the problem shall be resolved prior to continuing paving operations. The criteria for mixtures containing PG 76-28 asphalt cements shall be 235 °F. The minimum compaction temperatures may be adjusted according to the asphalt binder supplier recommendations. Adjusted minimum compaction temperatures must be shown on the approved mix design or on other asphalt binder supplier documents, and be available on the job site. Pay Reduction criteria in Section 25.14 shall still apply in such cases.

All roller marks shall be removed with the finish rolling. Use of vibratory rollers with the vibrator on will not be permitted on bridge decks.

The **General Contractor** shall establish a rolling pattern or procedure during the beginning of paving operations, which will achieve the required compaction and surface tolerances. This procedure may be re-evaluated by the **General Contractor** and **Construction Project Manager** throughout the paving operations.

All HMA paving shall be compacted to 94.0 ± 2 percent of Maximum Theoretical (RICE) Density, (CP-51 or AASHTO T-209: Maximum Specific Gravity of Bituminous Paving Mixtures) as determined by ASTM D 2950. RICE values shall be used in calculating Relative Compaction according to CP-44 or AASHTO T 166. The **General Contractor** shall determine the proper RICE value to use for the initial day's placement. Subsequent day's RICE value(s) will be based on the current day's production. The **General Contractor** shall provide the producer's RICE value, which shall be used for production until the actual day's RICE value is determined by the testing firm of record for the project as approved by the **Construction Project Manager**.

All joints shall be compacted to 92.0 ± 2 percent of RICE, taken fully on each side of joint, every 200 Linear Feet. RICE values shall be used in calculating Relative Compaction according to AASHTO T 166, Cores if need will be used to verify compaction results.

The **General Contractor** shall core the pavement, as required by the **Construction Project Manager**, for field density tests in accordance with Colorado Procedure 44 or AASHTO T 230, Method B, or for field calibration of nuclear density equipment in accordance with the ASTM D 2950 or Appendix of Colorado Procedure 81. At a minimum, cores for nuclear density equipment calibration shall be taken at the beginning of placement of each pavement layer or change of mixture materials or gradation. Untested areas during placement will also require cores to be taken to verify compaction.

Along forms, curbs, headers, walls, and all other places not accessible to the rollers, the mixture shall be thoroughly compacted with mechanical tampers.

Any mixture that becomes loose and broken, mixed with dirt, or is in any way defective, shall be immediately removed and replaced with fresh hot mixture and compacted to conform to the surrounding area.

Compaction requirements for SMA are covered in section 25.8.1. Rollers shall not be used in a vibratory mode on SMA unless they are first used successfully in the demonstration control strip. Pneumatic wheel rollers shall not be used on SMA Mix.

25.13 Production Tolerances

25.13.1 Top Lift Surface Tolerances

The variation between any two contacts with the surface shall not exceed 3/16 inch in 10 feet. For patching surface tolerances, the variation shall not exceed 3/8 inch in 10 feet. Irregularities exceeding the specified tolerance shall be corrected at the General Contractor's expense. Transverse measurements for variations shall exclude breaks in the crown sections.

25.13.2 Job Mix Formula Tolerances

Production test results that deviate from the design job mix by more than shown in the following table are subject to Section 25.14:

**Table 25.13.2.
Gradation Tolerances**

Item	
Passing No. 3/8" and Larger (note 1)	± 6%
Passing No. 4 and No.8	± 5%
Passing No. 30 to No. 50	± 4%
Passing No. 200 (note 2)	± 2%
Air Voids	± 1.2%
VMA (note 4)	± 1.2%
Hveem Stability	(note 3)
Asphalt Content	± 0. 3%

(Note 1) There is 1.0 percent tolerance for the maximum sieve size.

(Note 2) Mixes with passing No. 200 sieve material produced over 7.0 percent are allowed only when the above Air Voids and VMA tolerances are still met.

(Note 3) Hveem Stability must meet the minimum value specified in table 25.3.2.

(Note 4) When calculating VMA, use the most current aggregate specific gravity G_{sb} .

When disagreements concerning determination of specification compliance occur, only valid tests from the Construction Project Manager will be considered. The Construction Project Manager shall determine validity. Generally, valid tests are those in which sampling and test have been performed according to referenced procedures and the results are within stated precision statements. When disagreements occur with Asphalt Content and gradation tests results, solvent extracted aggregate testing shall take precedence over burn off oven extracted aggregate, which shall take precedent over cold feed belt testing.

25.14 CONFORMITY WITH PLANS AND SPECIFICATION

25.14.1 General

All work performed and all materials furnished shall conform to the lines, grades, cross sections, dimensions, and material requirements, including tolerances, shown in the contract.

For those items of work where working tolerances are not specified, the **General Contractor** shall perform the work in a manner consistent with reasonable and customary manufacturing and

construction practices.

When the **Construction Project Manager** determines that the material furnished, work performed, or the finished product is not in conformity with the contract and has resulted in inferior or unsatisfactory product, the finished product or materials shall be removed and replaced or otherwise corrected by, and at the expense of, the **General Contractor**.

Materials shall be sampled and tested by a qualified testing laboratory in accordance with the sampling, testing schedules, and procedures contained in the Section 25.15 Testing and Inspection. The approximate maximum quantity represented by each sample shall be as set forth in the testing schedule. An additional number of samples, in relation to the quantity of materials represented, may be selected and tested at the **Construction Project Manager's** discretion. The quantity represented by five consecutive random samples shall constitute a lot, whenever production schedules and material continuity permits. When it is necessary to represent short production runs, significant material changes, or other unusual characteristics of the work, the **Construction Project Manager** may establish a lot consisting of the quantity represented by any number of consecutive random samples from one to seven inclusive. Testing results that are determined to have sampling or testing errors, as determined by the **Construction Project Manager**, shall not be used.

25.15 Testing and Inspection

If any materials furnished or work performed by the **General Contractor** fails to fulfill the specification requirements, such deficiencies shall be reported to the **Construction Project Manager** and the **General Contractor** immediately. Preliminary written field reports of all tests taken and observation results shall be given to the **General Contractor** and **Construction Project Manager**, within 1 business day after samples were obtained or density testing performed. Field reports shall be forwarded to the Project Manager no later than 1 week following the testing.

Reports of all tests taken, including failing tests, shall be reported to the **Construction Project Manager** and to the **General Contractor** no later than 1 week following the sampling. Density test results will be given in writing at the time the testing occurs.

Testing of Hot Mix Asphalt Pavement shall be performed in accordance with Table 25.15. The tests shall be performed under the general supervision of and signed by a **Professional Engineer** registered in the State of Colorado. Laboratories shall be inspected by either AASHTO or accredited A2LA or equivalent in the elements listed below. Technicians taking samples and conducting compaction tests must have a LABCAT Level A certification or equivalent. Technicians conducting tests of asphalt content and gradation must have a LABCAT Level B certification or equivalent. Technicians performing volumetric testing must have a LABCAT Level C certification or equivalent.

**Table 25.15.1
Schedule for Minimum Materials Sampling and Testing**

Test	Standard*	Minimum Frequency
Sampling	AASHTO T 168, ASTM D 979 and ASTM D3665	One test for each day
Density	AASHTO T 166, T 238, T 230 Or CP-44, CP-81, CP-82	One test for each 250 lineal feet per Lane
Thickness (Core)	ASTM D 3549	One test for each 1000 lineal feet per Lane,
Air Voids & VMA	AASHTO T 166 & AASHTO PP 19 or CP-48	One test for each day (See note 4, Table 25.13.2)
Gradation	AASHTO T 27, T 11 or CP-31A, CP-31B	One test for each day
Asphalt (AC) Content	AASHTO T 164 or CP-L 5120 or other methods agreed upon between Construction Project Manager and General Contractor	One test for each day
Maximum Theoretical Specific Gravity (Rice)	AASHTO T 209 or CP-51	One test for each day
Lottman Stripping, TSR & Dry Density	AASHTO T 283 or CP-L 5109, Method B	As requested by the Construction Project Manager .
Micro Deval	AASHTO T 327 or CP-L 4211	One per 5000 tons or 1 per project minimum

Construction Project Manager or designee shall be responsible for checking temperatures of mix in truck and on pavement, segregation, rolling patterns and other construction means and method that affect the performance of the pavement system. The General Contractor shall provide assistance in sampling and testing at all facilities and at the job site.

End of Specification



CITY AND COUNTY OF DENVER
ENGINEERING DIVISION

Wastewater Capital Projects Management Standard Construction Specification

26.0 Excavation and Embankment

26.0.1 General

This work pertains to pond construction and consists of excavation, hauling, disposal, placement, and compaction of all material encountered on-site within the limits identified in the plans. All excavation and embankment for pond construction will be classified as “unclassified excavation” as hereafter described.

26.0.2 Referenced Standards

AASHTO M 145	Classification of soils and soil-aggregate mixtures
AASHTO T 99	Moisture-Density Relations of Soils using a 5.5-lb Rammer and a 12-inch Drop
AASHTO T 180	Moisture-Density Relations of Soils using a 10-lb Rammer and a 18-inch Drop

26.0.3 Excavation

Unclassified Excavation. Unclassified excavation shall consist of the excavation of all materials of whatever character required for the work, obtained within the pond construction project site, including surface boulders, masonry, organics, rocks, muck material, miscellaneous debris and slag that are not removed under some other item. The work also includes excavation for the ditches, channels, and placement, water and compaction of the material to construction embankments in accordance with the plans.

26.0.4 Embankment

Embankment: Embankment material shall consist of approved material acquired from excavations, hauled and placed in embankments. Approval of the embankment material will be contingent on the material having a maximum dry density of not less than 90 pounds per cubic foot. Soil embankment shall consist of materials obtained on-site and approved by the Engineer.

26.0.5 Construction Requirements

26.0.5.1 General

The excavations and embankments shall be finished to a smooth and uniform surface conforming to the line and grade specified. Variation from the subgrade plan elevations

specified shall not be more than 1.0 inch. Excavation operations shall be conducted so material outside of the slope limits will not be disturbed. Prior to beginning grading operations, all necessary clearing and grubbing and site demolition in that area shall be performed.

The Contractor shall notify the Engineer not less than ten working days prior to beginning excavation so the necessary cross sections may be taken. Baseline survey for purposes of payment of the unclassified excavation work item will be obtained by the CCD Survey Group. The baseline survey will be taken once all building and site demolition, including removal of the buildings, parking lots, driveways is complete. The baseline survey is intended to set the topography of the existing native soil below the pavements and building elevations. Once the pond construction is complete a second survey will be completed to determine the final quantity of unclassified excavation. The Contractor shall not excavate beyond the dimensions and elevations established.

26.0.5.2 Unclassified Excavation

All material to be excavated shall be stockpiled as subgrade material or removed from the site. Materials excavated beneath the top twenty six (26) inches shall, at the discretion of the Engineer, either be placed in the subgrade stockpile or removed from the site and disposed of at Denver Arapahoe Disposal Site (DADS). It shall be the responsibility of the Contractor to determine the amount of subgrade material to be stockpiled and necessary for completion of the work. All stockpiled material not used shall be disposed of per Contract requirements.

26.0.5.3 Embankment

Embankment construction shall include preparation of the areas upon which embankments are to be constructed, placing, moisture conditioning and compacting of approved material to the limits shown on the plans or as directed. Only approved materials shall be used in the construction of embankments and fills. The type of relative compaction required shall be a minimum of 95% of Standard Proctor density AASHTO T-99 within 2% of optimum moisture content.

The soil upon which the embankments are to be constructed shall be scarified to a depth of eight (8) inches and compacted with moisture and density control. The moisture content of the soil at the time of compaction shall be as specified or directed.

Embankment shall be placed in horizontal layers not to exceed six (6) inches loose measurement and shall be compacted as specified before the next layer is placed. Spreading equipment shall be used to obtain uniform thickness prior to compaction. As the compaction progresses, continuous mixing, leveling and manipulating shall be done to assure uniform moisture and density.

Embankments shall be constructed with moisture and density control. The moisture content of the soil at the time of compaction shall be as specified or directed. Maximum dry density of all soil types encountered or used will be determined in accordance with AASHTO T-99. The amount of water to be used in compacting A-2-6, A-2-7, A-4 and A-6 through A-7 soils shall not deviate from optimum on the dry side by more than two percentage points as determined by AASHTO T-99. A-4 soils, which are unstable at the above moisture content, shall be compacted at lower moisture content to the specified density.

Additional work involved in drying embankment material to the required moisture content shall be included in the work.

26.0.6 Finished Grade

Finished grade as shown on the plans or as directed shall be achieved by placement of a minimum of twelve (12) inches of compacted subgrade followed by placement of six (6) inches of topsoil. Materials, compaction, moisture and density requirements for the subgrade are as specified above.

End of Specification



CITY AND COUNTY OF DENVER
ENGINEERING DIVISION

Wastewater Capital Projects Management Standard Construction Specification

31-3223.12 Soil Improvement by Compaction Grouting

Part 1 - General

1.01 Introduction

A. Compaction grouting involves the injection under high pressure of a low-slump, mortar-like grout to compact and displace the adjacent soils. The grout does not penetrate soil pores but displaces the subsurface soils by forming a homogeneous grout bulb near the grout pipe tip.

B. In situ soil types: Refer to the project specific geotechnical report for soil types.

C. Applications: Loose fill stabilization; remediation of settling structures and utilities; sinkhole remediation; building/utility protection during tunneling; soil densification for site improvement; liquefaction mitigation. In certain cases, procedures can be designed to intentionally lift structures and/or utilities.

1.02 Intent

The intent of the compaction grouting specified herein is to provide soil improvement within the limits indicated on the Project Drawings to achieve the required degree of improvement detailed in these specifications.

1.03 Standards and References

A. The most recent version of the following testing methods or standards shall be employed:

1. ASTM D1586 Standard Penetration Testing (SPT) and Split-Barrel Sampling of Soils
2. ASTM C1019 Sampling and Testing Grout
3. ASTM C150/C150M Portland Cement
4. ASTM C143/C143M Slump of Hydraulic-Cement Concrete

B. Reference documents as provided to the grouting contractor shall include:

1. This specification.
2. Construction Drawings.
3. Project specific geotechnical report.
4. Bid Documents.

1.04 Definitions

A. *Compaction Grout*. A material blend of fine aggregate, fines and water to achieve a pumpable, thixotropic, viscous grout of a low slump to enable pumping at high pressure and remain intact after injection.

B. *Field Quality Control Representative (FQCR)*: The Contractor's representative given specific inspection tasks identified in this specification.

C. *Treated Zone* – the area requiring subgrade stabilization (compaction grouting) as measured between bedrock (or depth of refusal) and the subgrade of the facility to be supported

D. *Overburden/untreated zone* – the area as measured between the existing ground surface and the subgrade of the facility to be supported.

E. *Refusal* – **This definition relies on information provided by the approved contractor and is required as a submittal. In general Refusal is the point at which pipe advancement has stopped.** We agree that Refusal is based upon the physical limitations of the machine being used to advance the pipe. There is a point, based upon different mechanical limits, at which advancement ceases and may not be within the anticipated limits of bedrock.

F. *Geotechnical Data Report (GDR)* - A document that presents an interpretation of the known subsurface data for the project. The purpose of the GDR is to compile all geological, geotechnical, groundwater, and other data obtained from the geotechnical investigations for use by the various participants in the project. If available, this information will be included within the contract documents as specifically applicable to the project.

G. *Geotechnical Baseline Report (GBR)*- The intent of a GBR is to clearly and contractually define the geotechnical conditions through which tunneling will occur in order to evaluate a differing site condition (if encountered) and it is used as a basis of bid for the contractor. By assessing the anticipated geotechnical conditions for a project and providing baselines in the contract, the contractor has a basis from which to prepare their bid and select their means and methods. The baseline conditions do not necessarily reflect the actual conditions; they are not geotechnical fact to be encountered. Rather, they represent the owner's assumption of existing geotechnical conditions for the project. If available, this information will be included within the contract documents as specifically applicable to the project. Regardless of inclusion, this information shall be investigated, interpreted, verified and/or developed by the contractor prior to commencement of the work.

1.05 SCOPE OF WORK

A. The work shall consist of installation, monitoring and testing of compaction grouting within the limits indicated on the Drawings to meet the acceptance criteria presented in within these specifications.

B. In connection with the compaction grouting program, as shown on the drawings, the grouting contractor shall provide all labor, materials and equipment as detailed in the contract documents and within the Measurement and Payment to accomplish the work:

1.06 SUBMITTALS

A. The following shall be submitted to the Construction Project Manager by the General Contractor a minimum of two (2) weeks *prior to the start of the work*:

1. A ground movement monitoring plan, as detailed in this specification, if structures are located within a horizontal distance equal to the depth of treatment.

2. A mix design for the project indicating sources and types of grout materials, with volumetric proportions, and field test data from previous projects indicating compressive strength and slump of 1 inch or less achieved. If the grouting contractor intends to deviate from the gradation provided in this specification, the contractor shall submit evidence of satisfactory use of the proposed material from past projects with similar geotechnical conditions.

3. Work procedures and control criteria (including volumes and pressures for each stage).

4. A general Work Procedures Plan outlining the spacing as shown on the Drawings, location, depth and estimated quantity of grout to achieve the specified criteria detailed in this specification. Grout hole locations shall be dimensionally referenced to the facility foundation as shown on the Drawings.

- B. The following shall be submitted to the Construction Project Manager by the General Contractor *during construction*:
1. Accurate daily records of all grout pipe installation, compaction grouting quantities, including stage data, volume, pressure and depth for each grout pipe location.
 2. Any change in the predetermined grouting program necessitated by a change in the subsurface conditions.

Part 2 – Equipment and Materials

2.01 GROUTING EQUIPMENT

- A. The grouting contractor shall supply equipment capable of advancing the grout pipe through overburden, soils and other obstructions to the specified depth or as is required to meet the project objectives.
- B. The grouting contractor shall supply all equipment required to operate a compaction grouting system capable of supplying the specified grout at variable flow rates and pressures, measured at the pump, up to 250 psi and at rates of 0.5 to 12 cubic feet per minute, as required to suit the application.
- C. The mixer shall be a continuous auger type to ensure complete uniform mixing of the materials used and shall be of sufficient capacity to continuously provide the pumping unit with mixed grout at its normal pumping range. The mixer must be capable of volumetrically proportioning the grout materials.
- D. The grouting contractor shall provide gauges or other instrumentation (measuring devices) to measure:
 1. Continuous grout pressure close to the top of the injection casing
 2. Flow rate of grout.
 3. Volume or grout injected.
- E. The grouting contractor shall supply and install structural monitoring equipment in accordance with these specifications.
- F. A communication system shall be maintained between the pumping and batching plant and the injection location. As an alternate, the grouting contractor may furnish a remote control system to allow full control (start, stop, flow rate, reversing) of the pump directly by the contractor's personnel from the injection point).

2.02 GROUT PIPES

- A. Grout pipes and connections shall be steel casing of adequate strength to maintain the hole and to withstand the required jacking and pumping pressures. The pipes shall be at least 2.0 inches inside diameter in order to adequately handle the specified low slump material without plugging. All casing shall be flush joint threaded or a single piece tubing to provide a smooth inner wall and unobstructed inside diameter. It shall be the contractor's responsibility to install casing that does not detrimentally impact the grouting procedure.
- B. Pipes shall be installed such that grout material will not travel in the annular space between the pipe and adjacent ground and escape at the surface when pumped.

2.03 GROUT MATERIALS

- A. Portland Cement (ASTM C150)
- B. Fine aggregate shall be sand with fines content (percent passing No. 200 sieve) of not less than 10 percent and not more than 30 percent. Natural fines may be supplemented with Fly/ash, a minimal amount of bentonite, or aggregate washings.
- C. Proportions of the mixture shall be as required to achieve a pumpable mix with not more than 1 inch slump.
- D. Upon discharge into the pump hopper or holding tank, the grout must be continuously agitated. Mixed grout may not be held in the agitator for more than 1.5 hours unless a set retarder, approved by the Owner's representative, is used.

Part 3 – Execution

3.01 Site Examination

- A. If adjacent buildings are involved, a building survey shall be performed.

3.02 Compaction Grouting

- A. Compaction grouting shall be performed in accordance with the approved grout injection point layout scheme to achieve the following acceptance criteria in the in situ soil between the injection points:
 - 1. Post-grouting average, corrected Standard Penetration values exceeding 15 in typical site soils. Locations of the tests shall be agreed

upon between the grouting contractor, Construction Project Manager and FQCR and will be spaced at no greater than 100 foot intervals. At each location, the Standard Penetration tests will begin at the approximate bottom of the facility to be supported and will be taken at 3 to 5-ft intervals in the treated zone.

- B. Compaction grouting shall extend from bedrock up to the subgrade of the facility to be supported.
- C. The grout shall be injected in stages until one of the following occurs:
 - 1. Grout flow ceases at a gauge pressure reading of 50 to 150 psi (250 psi maximum) or,
 - 2. Surface ground heave of 1 inch as measured via survey or,
 - 3. An injected grout volume equal to approximately 2 to 6 cubic feet per 1 vertical linear foot of the material being treated.
- D. Compaction grouting shall be sequenced so that grouting does not take place within 4 feet of locations grouted within the previous 12 hours.
- E. As compaction grouting is completed at each location, the grouting contractor shall completely fill the grout hole to the ground surface with an approved granular material.
- F. Should the contractor reach refusal, at an elevation other than that which is expected, the FQCR shall notify the Construction Project Inspector immediately.

3.03 Field Quality Control

The General Contractor's FQCR will ensure that procedures and documentation conform to these specifications.

- A. All compaction grouting shall be performed under the inspection of the FQCR.
- B. Monitoring and logging of compaction grouting operations for both test areas and production work shall be done by the grouting contractor and the FQCR.
- C. The FQCR will perform slump tests of grout and take measurements of grout mix quantities to verify the grouting contractor's grout mix, as follows:
 - 1. Slump tests will be performed a minimum of twice during each grout shift.
 - 2. Grout mix proportions will be checked a minimum of once daily.
- D. The FQCR will cast minimum size 2 inch by 4 inch grout test cylinders or 2 inch by 2 inch cube molds for strength testing (per ASTM C1019). One set of four cylinders or molds will be cast during each slump test.
- E. Layout of grout injection points shall be by the grouting contractor and checked by the FQCR and Project Inspector with survey control provided by the General Contractor.

- F. As detailed in this specification, daily records shall be maintained by the grouting contractor and submitted to the General Contractor on a daily basis.
- G. The grouting contractor shall monitor nearby structures as follows:
 - 1. A level control system will be installed by the contractor for each structure within a horizontal distance equal to the depth of treatment of the grouting operations.
 - 2. Monitoring shall be carried out on a continuing basis whenever compaction grouting is occurring within a horizontal distance equal to the depth of treatment.
 - 3. After completion of the compaction grouting program, the monitoring system and grout pipes will be removed and all holes will be filled with an approved material and the surface shall be restored to match existing materials.

As compaction grouting is completed at each location, the grouting contractor shall completely fill the grout hole to the ground surface with an approved granular material.

3.04 Testing and Inspection

- A. The effectiveness of the proposed grouting layout scheme shall be verified as follows:
 - 1. The Contractor's FQCR shall perform the in situ Standard Penetration testing as directed by the Construction Project Manager. Two test sections will be performed before and during production work, as follows:
 - a. Test section locations will be agreed upon by the FQCR, Project Inspector and Grouting Contractor within the treatment area. A test section shall consist of a single module comprised of at least three grout injection points for isolated footings and sixteen grout injection points for area applications (such as along the alignment of the facility being supported). Tests will be performed at the center of the module prior to and after grouting. Standard Penetration tests will begin at the approximate bottom of the facility being supported and will be taken at 3 to 5-ft intervals in the treated zone below the facility being supported.
 - b. All testing to determine specification compliance will be provided by the FQCR. The same test method shall be utilized both before and after the soil improvement work in order to provide the most accurate assessment of the degree of improvement obtained.
 - c. The method of installation of the test section shall comply with this specification and shall be performed using the same grout

line sizes, grout mix drilling and grouting equipment and procedures as that to be used for production work.

- d. Prior to commencement of production grouting, two (2) test sections shall be performed. If the pre-production test sections indicate that the required ground improvement has not been achieved, the grouting contractor shall revise the Work Procedure Plan and re-test at two (2) test sections.
- B. Monitoring and logging of compaction grouting operations in the test areas and for production work shall be done by the grouting contractor and submitted to the FQCR on a daily basis.

END OF SECTION



CITY AND COUNTY OF DENVER
ENGINEERING DIVISION

Wastewater Capital Projects Management Standard Construction Specification

47.0 Construction Survey and Monumentation

47.0.1 Description

The Contractor shall be responsible for construction surveying, calculating, and staking necessary for the construction of all elements of the project. The Contractor shall also provide locating, preserving, referencing, installing and restoring of land monuments based upon the project's Land Survey Control drawing(s) as provided in the Contract Documents. Unless otherwise noted, payment for construction surveying and monumentation shall be via separate bid items.

The work shall be done under the supervision of a Professional Land Surveyor (PLS) who is experienced and competent in storm sewer construction, sanitary sewer construction and roadway construction surveying and licensed in the State of Colorado.

The PLS shall be available to review work, resolve problems, and make decisions in a timely manner.

47.0.2 Materials and Equipment

The Contractor shall furnish all personnel, survey equipment, safety equipment, materials, and traffic control necessary to perform the required construction surveying and staking. If any survey equipment is found to be functioning outside the manufacturer's specified tolerance, certification from an approved repair facility showing that the instruments have been repaired, properly adjusted, or both if necessary shall be included in the survey records and submitted to the City Surveyor's Office before being used.

47.0.3 Construction Requirements

A Construction Survey Conference shall be held with the City Surveyor's Office prior to performing any surveying work under this section. The Contractor's Surveyor (PLS) and Party Chief shall attend. A Construction Survey Checklist shall be completed and signed by the City Surveyor's Office and the contractor.

The Contractor shall check and verify all established Primary horizontal and vertical control points.

All survey records generated shall be the property of the City and shall be available to the City Surveyor's Office for inspection or reproduction at all times. All survey records shall be

transmitted to the City Surveyor's Office for inclusion into the project records before final project acceptance.

Electronic formats may be acceptable, please coordinate with the City Surveyor's Office.

Copies of any new Monument Records filed by the PLS with the State Board of Registration shall be submitted to the City Surveyor prior to filing.

47.0.4 Construction Surveying

The Contractor's PLS shall perform all construction surveying and staking that is necessary for construction of the project. Additionally, the contractor shall establish and maintain control points and stationing during construction to allow the City's Project Manager or designee a reference to determine contract pay quantities.

47.0.5 Staking

It is the responsibility of the Contractor's PLS to adhere to industry standards and acceptable practices in regards to staking. Any re-staking will be the responsibility of the Contractor at no cost to the City.

47.0.6 Accuracy and Tolerances

It is the responsibility of the Contractor's PLS to adhere to industry standards and applicable standards with regard to horizontal and vertical accuracy tolerances.

47.0.7 Responsibility and Inspections

Supervision and coordination of construction surveying and staking is the Contractor's responsibility. The City Surveyor may inspect the Contractor's surveying; however such inspection will not relieve the Contractor of any responsibility for accuracy or completeness of work. The Contractor shall check the work to verify the accuracy and include documentation of this check in the Survey Records. All Contractor surveying inaccuracies, errors, or omissions shall be corrected at the Contractor's expense. The City Surveyor's inspection or the Contractor's corrections shall not entitle the Contractor to additional payment or contract time extension.

Survey control, benchmarks, and other significant stakes that are damaged, destroyed, or made inaccessible by the progress of construction shall be replaced, transferred or reestablished at the Contractor's expense.

47.0.8 Changes

All changes in lines and grades required by the field conditions and all discrepancies in grades, alignments, locations or dimensions detected by the Contractor shall be immediately submitted to the City Project Manager in writing. No changes in given data or plans will be allowed unless approved by the City Project Manager in writing. All changes shall be documented in the survey records.

47.0.9 Traffic Control

Traffic control necessary for surveying and monumentation work shall not be measured and paid for separately. All traffic control costs incurred due to this work shall be included within the associated bid item(s).

47.0.10 Survey Records

Survey records shall be completed as the work is done. Field survey notes for construction surveying and checking by the Contractor shall be recorded in survey records in conformance with industry standards and acceptable practices.

All survey records generated shall be the property of the City and shall be available to the City Surveyor's Office or the City Construction Project Manager for inspection or reproduction at all times. All survey records shall be transmitted to the City Surveyor's Office for inclusion into the project records before final project acceptance. All survey records shall be stamped with the seal of, and signed by, the responsible PLS.

"As-built" and "Red-lined" drawings and prints necessary for the construction and preparation of record drawings for all elements of the project shall be the responsibility of the Contractor.

All "As-built" and "Red-lined" drawings generated shall be the property of the City and shall be submitted to the Construction Project Manager upon completion. In addition to red-lined prints, the Contractor shall supply the Construction Project Manager with electronic survey data information in the form ".asc", ".txt", and/or ".dwg" files upon request.

47.0.11 Survey Monumentation

This work consists of locating, preserving, referencing, installing and restoring land monuments as indicated in the Land Survey Control drawing(s) for the specific contract. Survey Monumentation includes but is not limited to: City of Denver Range Points and accessories, Primary Control monuments from which the Right of Way or any land boundary will be calculated, described or monumented, Public Land Survey System (PLSS) monuments, Right of Way (ROW) monuments, General Land Office (GLO) monuments, Bureau of Land Management (BLM) monuments, Mineral Survey (MS) monuments, property boundary monuments and offsets, benchmarks, easement monuments, and other monuments that are required by law or regulation to be established and recorded by a Professional Land Surveyor (PLS).

At the closeout of the project the following Survey documents shall be submitted to the City Surveyor for review and acceptance:

1. City and County of Denver Monument Tie Out Sheets for all range points within the project influence.
2. A survey of all project monumentation per State Statute.

The production of additional documentation may be required by the City Surveyors' Office. All such work included in this section shall be under the supervision of a PLS who is licensed in the State of Colorado.

47.0.12 Reset Monuments

Survey monuments, benchmarks, and other significant monuments that are damaged, destroyed, or made inaccessible by the progress of construction shall be replaced, transferred or reestablished at the Contractor's expense.

Locating, preserving, referencing, installing and restoring land monuments as described in this specification shall be done under the supervision of a PLS who is experienced and competent in Right of Way and boundary surveying and licensed in the State of Colorado

47.0.13 Locating Monuments

This work consists of field locating all survey monumentation as discussed in 47.0.11 which is in place within the project limits. A diligent search of construction zones and project limits shall be performed by the PLS.

47.0.14 Preserving and Referencing Monuments

All monuments as described in this specification shall be preserved, referenced and reset by the Contractor's PLS within the project limits.

47.0.15 Installing Monuments

All monuments as described in the contract documents shall be preserved through construction. If any monuments are to be disturbed/removed during construction, it will be the contractor's responsibility to have all monuments reset to current City of Denver standards. Appropriate documentation will be required for all reset monuments.

47.0.16 Monument Box

This survey work shall consist of installing or adjusting monument boxes to current City or State requirements.

47.0.17 Method of Measurement

All survey work will be paid for via the associated bid item(s) and in accordance with the respective Measurement and Payment portions of the Contract Documents.

End of Specification



CITY AND COUNTY OF DENVER
ENGINEERING DIVISION

**Wastewater Capital Projects Management
Standard Construction Specifications**

Measurement and Payment

September 26, 2014

Measurement and Payment

01-5213 Temporary Office Facilities

No quantity measurement will be made for any of the work and materials required to accomplish this aspect of the project and payment will be based upon the percentage of this work item completed in accordance with the plans and specifications and as approved by the City Construction Project Manager.

This item includes: furnishing, installing, maintaining, cleaning, periodic inspections, adjustments and modifications, and removal of all temporary office facilities; providing utilities and services including but not limited to the following: water, electric, telephone, DSL hard line, acceptable scanner, copy machine, printer, internet, sanitary facilities, security measures, storage areas, etc. and payment of associated monthly bills during project duration; development and maintenance of access and haul routes, furnishing and installation of temporary construction fencing; securing temporary facility location, securing of required permits, payment of all associated fees, restoring the site to a better or equal condition than prior to use, and all other equipment and labor required for the implementation, maintenance and removal of all temporary office facilities.

At the option of the Construction Project Manager, one quarter of the lump sum price for temporary office facilities may be paid to the Contractor at the time of the first monthly progress payment, the second quarter may be paid at the time of the second monthly progress payment, and the third quarter may be paid to the Contractor at the time of the third monthly progress payment, or at the discretion of the Construction Project Manager. The total payment for this bid item shall not exceed seventy-five percent (75%) of the lump sum price during construction. The remaining twenty-five percent (25%) shall be paid after all facilities have been completely removed and the location of said facilities has been returned to an equal or better condition than prior to use by the Contractor.

02-2213 Vibration Assessment

No quantity measurement will be made for any of the work and materials required to accomplish this aspect of the project and payment will be based upon the completion of the work in accordance with the Contract Documents.

The lump sum price for Vibration Assessment shall include all of the Contractor's costs of whatsoever nature. The price bid shall include: all labor, equipment, materials, subcontractors, and transportation to and from project site required to complete vibration monitoring and assessment during the entire project duration regardless of extensions; furnishing submittals, baseline and monthly reports; theft and vandalism protection; web based data access and site training; incidentals; meetings and coordination with business owners and residents as necessary during construction; and all other related and necessary materials work and equipment required to accomplish this item in accordance with the Contract Documents.

At the option of the Construction Project Manager, one third of the lump sum price for this item may be paid to the Contractor upon satisfactory completion of and/or incorporation of proper measures. The second third may be paid upon fifty percent completion of the work as determined by the percent of work completed on the day of progress payment. The last third may be paid to the Contractor at the time of final progress payment or at the discretion of the Construction Project Manager.

Measurement and Payment

02_8216.10 Certified Asbestos Inspector (CABI)/Air Monitor

No quantity measurement will be made for any of the work and materials required to accomplish this aspect of the construction and payment will be based upon completion of the work in accordance with the Contract Documents. The lump sum price bid shall include the coordination and performance of an onsite CABI and air monitoring.

The lump sum price for the CABI/air monitor shall include all of the Contractor's costs of whatsoever nature, including licensing and certification of the CABI. The price bid shall include: all labor, materials and equipment required for the inspector to monitor the construction site, evaluate potential asbestos containing material, and collect air fiber samples; lab testing as required ; and all other related and necessary materials, work, and equipment required for completion of this work in accordance with the Contract Documents. Duties of the CABI/Air monitor shall be to monitor and cause to enforce that all project activities, excavations, and site controls are in compliance with Denver Environmental Health – Asbestos-Contaminated Soil Management Standard Operating Procedure (current version); all state and federal laws and regulations and guidelines; provide asbestos awareness training for all personnel associated with the project; and any other duties as defined within a site specific Material Management Plan.

At the option of the Construction Project Manager, monthly percentage payments, based upon Period of Performance, may be paid to the contractor upon satisfactory completion of and/or proper controls submitted in monthly payment application, or at the discretion of the Construction Project Manager. Up to the last progress payment or at the discretion of the Construction Project Manager.

31-3223.12 Soil Improvement by Compaction Grouting

The measurement for payment of this item will be the total number of vertical lineal feet of soil improvement by compaction grouting as measured between bedrock (or depth of refusal) and the subgrade of the proposed facility to be supported (treated area).

Measurement will be based on the total vertical linear feet that the grout injection rod advances from the existing ground surface to bedrock or refusal less the plan depth at the grout port location (as shown on the plans) for rod advancement measured from ground surface to subgrade of the facility to be supported (untreated area). Drilling logs showing actual vertical lineal footages of rod advancement depth through the untreated area and into the treated area shall be provided by the contractor as basis for payment of this item.

Payment will be made based upon documented drilling logs showing the vertical linear feet of complete, in place, in a manner satisfactory to the Construction Project Manager, provided, however no payment will be made for compaction grouting due to negligence or unauthorized operations by the Contractor.

The unit price bid per vertical linear foot of compaction grouting within the treated zone shall include all of the Contractor's costs of whatsoever nature. The price bid shall include: all labor, equipment, materials, grout, testing ground/structure monitoring system, installation and removal of grout pipes, furnish and injection of compaction grout, monitoring of ground/structure movements; survey, following the grouting sequence of operations as set forth in the contract documents, monitoring of all vertical measurements, all revisions of work plans and retesting to establish if grouting meets the contract requirements; hauling and disposal of construction debris, unsuitable material and contaminated materials at the Denver Arapahoe Disposal Site (DADS); in accordance with all specifications included within the contract documents. The Contractor shall be responsible for obtaining all permits, field verification of all utilities

Measurement and Payment

31-3223.12a Overburden Penetration for Compaction Grouting

The measurement for payment of this item will be the total number of vertical linear feet of overburden penetration during soil improvement by compaction grouting as measured between the existing ground surface to the subgrade of the proposed facility to be supported (untreated area). Measurement will be based on vertical linear feet (plan depth) at the grout port location (as shown on the plans) for rod advancement measured from ground surface to subgrade of the facility to be supported (untreated area). Drilling logs showing actual vertical lineal footages of rod advancement depth through the untreated area and into the treated area shall be provided by the contractor as basis for payment of this item.

Payment will only be made based upon the plan depth of overburden penetration measured in vertical linear feet and as documented in drilling logs showing the vertical linear feet of overburden penetration, where successful grout placement has occurred, and as in a manner satisfactory to the Construction Project Manager, provided, however no payment will be made for overburden penetration due to negligence or unauthorized operations by the Contractor.

The unit price bid per linear foot of overburden penetration for compaction grouting shall include all of the Contractor's costs of whatsoever nature. The price bid shall include: steel casing pipe and all labor, equipment, materials and all other related and necessary items, complete in accordance with the Contract Documents.

- 2-1.1a Remove Combination Concrete Curb, Gutter and Sidewalk (2'8")**
- 2-1.1b Remove Combination Concrete Curb, Gutter and Sidewalk (3'11")**
- 2-1.2a Remove 6" Concrete Curb and/or Gutter**
- 2-1.2b Remove 9" Concrete Curb and/or Gutter**
- 2-1.3 Remove Concrete Curb Head**
- 2-1.4 Remove Handicap Concrete Curb Ramp**
- 2-1.5 Remove Concrete Median Strip**
- 2-2.1 Remove Concrete Sidewalk**
- 2-2.1a Remove Concrete Sidewalk/Bike Path**
- 2-2.2 Remove Concrete Driveway Paving**
- 2-2.4 Remove Concrete Channel Paving**
- 2-2.5 Remove Miscellaneous Concrete Flatwork**

The measurement for payment of this item will be the total number of linear feet or square feet of existing concrete curb and gutter, combination concrete curb and gutter, concrete curb head, concrete handicap curb ramp, concrete median strip, concrete sidewalk, concrete bike path, concrete driveway pavement, concrete slab, concrete alley return, concrete alley paving, concrete channel paving or any other type of miscellaneous concrete flatwork as specified in the Contract Documents or designated by the Construction Project Manager to be removed for construction of the proposed sewer and/or appurtenances; provided, however, no measurement for payment will be made for concrete flatwork removed or damaged due to negligence or unauthorized operations by the Contractor.

The unit price bid per linear foot or square foot removal of this item shall include all of the Contractor's costs of whatsoever nature. The price bid shall include: excavation, concrete sawing or otherwise effectively cutting the concrete item smoothly and squarely in a manner satisfactory to the Construction Project Manager; excavation and overexcavation; removal and disposal of unsuitable material, existing flatwork and/or any reinforcing materials per the requirements set forth in the Contract Documents; and all other related and necessary materials, work, and equipment required to remove this item in accordance with the Contract Documents.

Measurement and Payment

2-2.6 Remove and Replace Flagstone Curb Head

2-2.7 Remove and Replace Flagstone Walk

The measurement for payment of this item will be the total number of linear feet of Flagstone Curb Head or the total square feet of flagstone walk required to be removed or placed for construction of the proposed sewer and/or appurtenances; provided, however, no measurement for payment will be made for flagstone removed and replaced due to negligent or unauthorized operations by the Contractor.

The unit price bid per linear foot or square foot removal and replacement of this item shall include all of the Contractor's costs of whatsoever nature. The price bid shall include: excavation, sawing or otherwise effectively cutting the flagstone item smoothly and squarely in a manner satisfactory to the Construction Project Manager; excavation and over excavation; removal and disposal of unsuitable material; storing on site for reuse; placement and/or replacement of flagstone; furnishing of new flagstone or equivalent stone as necessary; cutting, shaping, leveling, grouting, spacing; bedding, supply and placement of select subgrade material or select fill as necessary, compaction, and all other related and necessary materials, work, and equipment required to remove and replace this item in accordance with the Contract Documents.

2-2.8 Remove Asphalt Walk

The measurement and payment of this item will be the total number of linear feet of asphalt walk required to be removed, and/or removed and replaced for the proposed sewer and/or appurtenances; provided, however, no measurement for payment will be made for asphalt walk removal or replacement required due to negligent or unauthorized operations by the Contractor.

The unit price bid per linear foot removal, removal and replacement, or placement of this item shall include all of the Contractor's costs of whatsoever nature. The price bid shall include: excavation, grading and shaping; placement of bedding; excavation and overexcavation; removal and disposal of unsuitable material; placement and/or replacement; furnishing of asphalt; leveling and compaction, and all other related and necessary materials, work, and equipment required to remove this item in accordance with the Contract Documents.

2-3 Remove Concrete Wheel Stops

The measurement for payment of this item will be the total number existing wheel stops required to be removed or placed for construction of the proposed sewer and/or appurtenances; provided, however, no measurement for payment will be made for wheel stops removed and replaced due to negligent or unauthorized operations by the Contractor.

The unit price bid per wheel stop removal shall include all of the Contractor's costs of whatsoever nature. The price bid shall include: excavation, sawing or otherwise effectively removing the wheel stop in a manner satisfactory to the Construction Project Manager; excavation and overexcavation; removal and disposal of unsuitable material; storing on site for reuse; placement of replacement; furnishing of new wheel stops; cutting, leveling, grouting, spacing; bedding, compaction, and all other related and necessary materials, work, and equipment required to remove this item in accordance with the Contract Documents.

2-3.1 Remove Concrete Alley Gutter

2-3.2 Remove Concrete Alley Returns

2-3.3 Remove Concrete Alley Paving

2-3.4 Remove Concrete Street Intersection Gutter (Crossspan) and/Or Valley Gutter

Measurement and Payment

2-3.5 Remove Concrete Street Paving

The measurement for payment of this item will be the total number of square feet of concrete required to be removed for construction of the proposed sewer; provided, however, no payment will be made for damaged material required to be removed due to negligence or unauthorized operations by the Contractor or any Subcontractors.

The unit price bid per square foot for removing this item shall include all of the Contractor's costs of whatsoever nature. The price bid shall include: concrete sawing and otherwise effectively cutting the existing concrete smoothly and squarely in a manner satisfactory to the Construction Project Manager; removal and disposal of concrete, asphalt, and/or any reinforcing materials, including removal of the square radius beyond the lip of the standard two-foot gutter; furnishing additional base material; subgrade preparation and compaction; rotomilling within the effective removal limits; and all other related and necessary materials, work, and equipment required to accomplish the removal of this item in accordance with the Contract Documents.

In addition to the above listed items, the unit price bid per square foot removal of concrete street intersection gutter and/or valley gutter shall include repaving of the street within the effective removal limits to a point not less than 2-inches below the new finished street grade (matching cross street crowns to within 2-inches of finished street grade to the satisfaction of the Construction Project Manager), including surrounding areas damaged during removal. The effective removal limits encompass the surface area shown on the Project Paving Schematic included within the Contract Documents. This area varies based on location within the project. The additional 2-inches of paving within the effective removal limits, as well as all required rotomilling and asphalt placement outside the limits will be paid for using bid items

provided for elsewhere in the Contract Documents. No separate measurement or payment will be made for additional paving materials or rotomilling necessary for adherence to this item, all such costs will be included in the square foot price for removal.

2-4 Remove Concrete Steps

The measurement for payment of this item will be the total number of square feet of concrete steps required to be removed for construction of the proposed sewer and/or appurtenances; provided, however, no measurement for payment will be made for concrete steps removed and replaced due to negligent or unauthorized operations by the Contractor.

The unit price bid per square foot of concrete steps, which shall be quantified by the width of the stairs multiplied by the summation of each stair hypotenuse (the hypotenuse of the rise and run of each stair). The unit price shall include all of the Contractor's costs of whatsoever nature. The price bid shall include: excavation, sawing or otherwise effectively removing the steps in a manner satisfactory to the Construction Project Manager; excavation and overexcavation; removal of any foundation concrete; removal and disposal of unsuitable material; backfilling of foundation with suitable bedding, compaction, and all other related and necessary materials, work, and equipment required to remove this item in accordance with the Contract Documents.

2-5 Remove Concrete Retaining Wall

The measurement for payment of this item will be the total number of linear feet of retaining wall, including attached railing and/or fence required to be removed for construction of the proposed sewer and/or appurtenances; provided, however, no measurement for payment will be made for retaining wall removal required due to negligent or unauthorized operations by the Contractor.

Measurement and Payment

The unit price bid per linear foot of retaining wall removal shall include all of the Contractor's costs of whatsoever nature. The price bid shall include: excavation, sawing or otherwise effectively removing the wall in a manner satisfactory to the Construction Project Manager; excavation and overexcavation; removal of any foundation concrete; removal of tie backs, drainage pipe; removal and disposal of fence and/or railings; removal and disposal of unsuitable material; removal of brick, wood, cinder block, steel sheeting, or rock walls; backfilling of foundation with suitable bedding, compaction, and all other related and necessary materials, work, and equipment required to remove this item in accordance with the Contract Documents.

2-6 Remove Concrete Headwall

No partial measurement for payment will be made for this item, removal and payment will be based upon complete removal of the concrete headwall and/or attached railing and/or fence to the satisfaction of the Construction Project Manager or to the requirements of the Contract Documents; provided, however, no measurement for payment will be made for retaining wall removal required due to negligent or unauthorized operations by the Contractor.

The unit price bid per lump sum concrete headwall removal shall include all of the Contractor's costs of whatsoever nature. The price bid shall include: effectively removing the wall in a manner satisfactory to the Construction Project Manager; excavation and overexcavation; removal of any foundation concrete; removal of tie backs, drainage pipe; removal and disposal of unsuitable material; removal of brick, wood, cinder block, steel sheeting, or rock headwalls; removal and disposal of fence and/or railings; backfilling of foundation with suitable bedding, compaction, and all other related and necessary materials, work, and equipment required to remove this item in accordance with the Contract Documents.

2-11 Remove or Abandon Existing Pipe and Box Culverts

8-4 Remove Existing Waterline

The measurement and payment for this item will be the total number of linear feet of existing pipe, flared end sections, box culvert, and/or waterline of the dimensions specified, required to be removed or abandoned for construction of the proposed sewer and/or appurtenances; however, no payment will be made for pipe removed or abandoned due to negligence or unauthorized operations by the Contractor.

The unit price bid per linear foot of removal or abandonment shall include all of the Contractor's costs of whatsoever nature. The price bid shall include: excavation; care and diversion of drainage courses; removal of pipe, cone sections and sewer appurtenances as necessary to complete the removal or abandonment as specified in the Contract Documents including removal and disposal of the existing conduit and appurtenances (per State and Local requirements where applicable for lines containing asbestos); hauling and disposal of construction debris, unsuitable material and contaminated materials at the Denver Arapahoe Disposal Site (DADS); removal of pavement, sod and other surfacing materials; excavation, including exploratory excavation; diversion, cutting and plugging of pipe, as necessary, per the Contract Documents, any additional labor, equipment and materials required to disconnect the existing facility as required by the owner, salvaging of pipe when directed by the Construction Project Manager or when specified in the Contract Documents, placing of the salvaged pipe on the job site in a location designated by the Construction Project Manager; reforming and reshaping of manhole inverts as required; backfilling to final grade with approved backfill material; filling of abandoned pipe with an approved CLSM or alternately approved product, per the requirements set forth in the Standard Construction Specifications; compaction of

Measurement and Payment

materials as necessary; paving, curb, gutter, sidewalk, landscaping and any other surface restoration required due to removal of associated items; coordination with utility owner as required and all other related and necessary materials, work, and equipment required to complete removal or abandonment in accordance with the Contract Documents.

2-11.8 Remove Abandoned Steam Pipe With Asbestos Lining (<24" Diameter)

The measurement for payment of this item will be the total number of linear feet of pipe required to be removed and transported to an approved disposal site for construction of the proposed sewer; provided, however, no payment will be made for removal due to negligence or unauthorized operations by the Contractor or any Subcontractors.

The removal of abandoned steam pipe with asbestos lining shall comply with Colorado State Regulation No. 8, Part B, which incorporates the Environmental Protection Agency (EPA) National Emissions Standards for Hazardous Air Pollutants (NESHAP) Regulations for Asbestos (40 CFR Part 61). More specifically, the removal activity must comply with § III.S.4. (Other Non-friable Asbestos-Containing Materials) and if at a quantity above trigger levels (§I.B.104) are also subject to § III.E. (State Notifications) of the stated regulation. If during abatement, the asbestos cement product becomes friable, the project activity shall meet and conform with all the requirements in sections I (Definitions), II (Certification Requirements), and III (Abatement, Renovation and Demolition Projects) of the stated regulation. All abatement projects involving asbestos products are subject to Occupation Safety and Health Administration (OSHA) Standards for Asbestos (29 CFR Parts 1910.1001 and 1926.1101). Transportation of asbestos-containing waste materials is regulated by the Colorado Department of Transportation (CDOT). All expenses incurred to comply with the above noted items shall be borne by the Contractor.

The unit price bid per linear foot for removal shall include all of the Contractor's costs of whatsoever nature. The price bid shall include: excavation; care and diversion of drainage courses; removal of pipe, insulating materials and appurtenances; removal of pavement, sod, and other surfacing materials; excavation, including exploratory excavation; coordination and interaction with abandoned facility owner to ensure that a chain of custody is maintained; hauling and disposal of construction debris, excess excavated material, damaged materials and asbestos contaminated materials at the Denver Arapahoe Disposal Site (DADS) unless otherwise specified or required by State regulations; backfilling and compaction to final grade with an approved backfill material; and all other related and necessary materials, work and equipment required to remove the existing abandoned steam pipe with asbestos lining in accordance with the Contract Documents.

2-12.1 Remove Existing Sanitary Manhole

2-12.2 Remove Existing Storm Manhole

2-12.3 Abandon Existing Sanitary Manhole

2-12.4 Abandon Existing Storm Manhole

2-12.7 Remove Existing Structure

2-13.1 Remove Existing Storm Inlet

2-13.2 Remove Existing Special Storm Inlet

The measurement for payment of this item will be the total number of manholes, inlets or structures required to be removed or abandoned for construction of the proposed sewer and/or appurtenances; however, no payment will be made for structures removed due to negligence or unauthorized operations by the Contractor.

The unit price bid per manhole, inlet or structure removal and/or abandonment shall include all of the Contractor's costs of whatsoever nature. The price bid shall include: excavation,

Measurement and Payment

overexcavation, exploratory excavation; care and diversion of drainage courses; removal of brick, grate, ring and cover, manhole barrel sections, concrete and any related reinforcing materials, unsuitable material, reducers, etc. to a minimum of 2 foot below finish grade; removal of pavement and sod; cutting and plugging of associated pipe per the Contract Documents, or as required by the Construction Project Manager; salvaging of ring and cover or grates when so designated by the Construction Project Manager; storing of all salvaged materials on the job site at a location designated by the Construction Project Manager; disposal of unsuitable material; placement of approved backfill material and/or Controlled Low Strength Material to final grade elevation, compaction; removal and replacement of paving, curb, gutter, sidewalk, landscaping and any other surface restoration required due to removal of associated item, unless specifically provided for elsewhere in the Contract Documents; and all other related and necessary materials, work, and equipment required to remove, abandon and/or salvage the existing structure in accordance with the Contract Documents.

2-12.5 Rehabilitate Existing Sanitary Manhole

2-12.6 Rehabilitate Existing Storm Manhole

The measurement for payment of this item will be the total number of vertical linear feet for individual manholes or structures, of the specified diameter, requiring rehabilitation for construction of the proposed sewer facilities, complete, in place, in a manner satisfactory to the Construction Project Manager, provided, however, no payment will be made for manholes or structures required to be rehabilitated due to negligence or unauthorized operations by the Contractor.

As part of the cost of this bid item, the Contractor, shall provide all necessary labor, equipment and materials required to re-inspect all rehabilitated manholes at two intervals, once at 18 months, and once at 34 months after final acceptance to address any warranty related work. The City's Construction Project Manager will contact the Contractor to schedule these inspections.

The price bid per vertical linear foot of rehabilitation of manholes and/or structures shall include all of the Contractor's costs of whatsoever nature. The price bid for rehabilitation shall include but not be limited to: furnishing, transporting, installing, setting up of all equipment and all materials and labor necessary to clean the manhole to be rehabilitated; furnishing labor and equipment required to by-pass pump, furnishing water for cleaning; furnishing energy required for power equipment; supplying all materials and equipment necessary to line the entire interior of manhole; reconstruction of the invert, bench, manhole steps and joints in accordance with the Contract Documents; concrete sawing or otherwise effectively cutting the manhole smoothly and squarely in a manner satisfactory to the Construction Project Manager; furnishing, transporting and installing manhole liner, concrete, reinforcement, brick, mortar, plastic joints sealant and grout, steps and other miscellaneous items as required to rehabilitate the specified manholes and/or structure; removal and disposal of unsuitable material; replacement with material as approved by the Construction Project Manager; flagging, barricading, traffic control; warranty inspections and travel to and from site; and all other related and necessary materials, work, and equipment required for complete rehabilitation of the manhole or structure in a manner satisfactory to the Construction Project Manager and in accordance with the Contract Documents.

2-14 Remove Riprap

2-15 Remove Gabions

The measurement for payment of this item will be the total number of cubic yards of riprap, gabions or other rock materials required to be removed for construction of the proposed sewer

Measurement and Payment

and/or appurtenances; provide, however no measurement for payment will be made for rock required to be removed due to negligence or unauthorized operations by the Contractor.

The unit price bid shall include all of the Contractor's costs of whatsoever nature. The price bid for removal shall include; excavation, backfilling, removal and disposal of unsuitable material, compaction and all other related and necessary materials, work, and equipment required to remove the riprap or gabions in accordance with the Contract Documents.

-
- 2-16.1 Remove Chain Link Fence**
 - 2-16.2 Remove Wood Fence**
 - 2-16.3a Remove Single Swing Gate**
 - 2-16.3b Remove Double Swing Gate**
 - 2-16.4 Remove Security Fence**
 - 2-18 Remove Permanent Barricades**
 - 2-21.1 Remove Guard Rail**
 - 2-21.2 Remove Hand Rail**

The measurement for payment of this item will be the total number of linear feet of wood fence, chain link fence, security fencing, gate work, guard rail, hand rail, or the number of barricades required to be removed for construction of the proposed sewer and/or appurtenances; provided, however, no measurement for payment will be made for items required to be removed due to negligence or unauthorized operations by the Contractor.

The unit price bid per linear foot of removal shall include all of the Contractor's costs of whatsoever nature. The price bid shall include: removal and disposal of materials to include: concrete bases, rails, posts, pickets, wire, fabric, slats, w-beams, nails, nuts, bolts, fencing, etc.; removal and salvage of materials if determined to be reusable by the Construction Project Manager; filling postholes, backfilling and regrading as necessary to promote drainage and eliminate safety hazards; and all other related and necessary materials, work and equipment required to complete the removal in accordance with the Contract Documents.

-
- 2-17.1 Remove and Replace/Relocate Utility Poles**
 - 2-17.2 Temporary Utility Pole**
 - 2-17.3 Remove and Replace/Relocate Sign**
 - 2-17.5 Remove and Replace Parking Meter Pole**

The measurement and payment of this item will be the total number of utility poles, parking meter poles and/or signs required to be removed and/or removed and relocated or replaced, and the total number of temporary poles placed and removed, for construction of the proposed sewer and/or appurtenances; provided, however, no measurement for payment will be made for poles removed due to unauthorized operations of the Contractor.

The unit price bid shall include all of the Contractor's costs of whatsoever nature. The price bid shall include: coordination with the utility owner; adherence to rules and procedures set forth by utility owners; scheduling relocations as required to insure that no time is lost for the project; excavation; removal and storage of poles and/or signs; replacement with new pole and/or signs if necessary; bedding, select fills, backfilling and compaction; removal and replacement of guy wires; drilling, casings; installation of new foundations to utility owner or Construction Project Manager's requirements as necessary; disposal of all trash and construction unsuitable material associated with this bid item; and all other related and necessary materials, labor and equipment required to complete the construction in accordance with the Contract Documents.

Measurement and Payment

2-17.7 Relocate Existing Utility

No quantity measurement will be made for any of the work and materials required to accomplish this aspect of the construction project and payment will be based upon the completion of the work in accordance with the Contract Documents.

The lump sum cost for coordination and relocation of the specified existing utility line shall include all of the Contractor's costs of whatsoever nature. The price bid shall include: coordination with the utility owner as necessary to complete the relocation; adherence to rules, regulations, specifications and procedures set forth by utility owner; obtaining all required permits and paying associated fees; railroad flagging/inspection and fees as necessary; shoring and trench support; hand digging as necessary; removal and disposal of concrete encasement material; removal and disposal of abandoned appurtenances; scheduling, rescheduling and facilitating all relocations as required to ensure the project stays on time, all associated delay costs; excavation as necessary for relocation of existing utility; removal, disposal and hauling of all construction debris, excess excavated material, unsuitable materials and manifested contaminated materials at the Denver Arapahoe Disposal Site (DADS), recycle and salvage of materials as required by contract; temporary utility supports; relocation of the utility; providing temporary service and rerouting as necessary; preserving service and continuity as required by utility owner; cutting of existing utility conduit and line as necessary; providing all materials, equipment and specialty labor necessary for reconnection of specific utility; brushing, cleaning and pigging of utility conduit as required by owner; providing and installing marking/tracing wire; concrete encasement of relocated utility as required and per utility company standards; traffic control supporting a standalone configuration; air testing; material testing; relocation engineering and plan development; directional boring if needed; removal and replacement of concrete flatwork at directional bore pits; specialized welding at points of connection and pipe junctions; backfilling and compaction after completion of relocate; and all other related and necessary materials, work and equipment required to relocate the existing utility as required in the Contract Documents or as directed by the Construction Project Manager.

2-19 Remove Existing Culvert

The measurement for payment of this item will be the total number of linear feet of concrete culvert or concrete channel required to be removed for construction of the proposed sewer and/or appurtenances; provided, however, no measurement for payment will be made for removal of culvert due to negligence or unauthorized operations by the Contractor.

The linear foot price bid for culvert removal shall include all of the Contractor's costs of whatsoever nature. The price bid shall include: excavation, including overexcavation to remove unsuitable foundation material; removal and disposal of all culvert materials including pipe, wood, concrete, reinforcing; backfilling and compaction; and all other related and necessary materials, work and equipment required to remove the culvert in accordance with the Contract Documents.

2-20a Remove Trolley Tracks

2-20b Remove Railroad Tracks

The measurement for payment of this item will be the actual number of linear feet per pair of trolley, street car, or railroad tracks required to be removed for construction; provided,

Measurement and Payment

however, no payment will be made for track removed due to negligence or unauthorized operations by the Contractor.

The unit price bid per linear foot removal of this item shall include all of the Contractor's costs of whatsoever nature. The linear foot price bid (per pair of rails) shall include: removal of paving within the entire track facility footprint and adjacent paving requiring removal to properly complete this item; cutting and disposal; stockpiling, storage and protection; or recycling of rails; removal and disposal of ties, fasteners, spikes, special joints; removal and disposal of special bedding and/or ballast under the tracks, removal and disposal of concrete panels and/or rubber matting; hauling and disposal of all excess excavated at the Denver Arapahoe Disposal Site; backfilling and compaction of subgrade with suitable material; temporary driving surfaces required prior to final pavement or new track installation, maintenance of temporary driving surfaces to includes removal and installation of new temporary surfaces as necessary prior to final treatment; and all other related and necessary materials, work and equipment required for removal of this item in accordance with the Contract Documents.

2-22 Remove Parking Lot Trench Drain

The measurement for payment of this item removal will be the actual number of linear feet of trench drain required to be removed for construction of the proposed sewer and/or appurtenances; provided, however, no payment will be made for trench drain removed due to negligence or unauthorized operations by the Contractor.

The unit price bid per linear foot removal of this item shall include all of the Contractor's costs of whatsoever nature. The price bid shall include: excavation, removal of concrete, unsuitable material, grates, backfilling and compaction; and all other related and necessary materials, work and equipment required for removal of this item in accordance with the Contract Documents.

2-23 Remove Decorative Landscaping

No quantity measurement will be made for any of the work and materials required to remove and replace this item. Payment will be based upon completion of the work in accordance with the Contract Documents; provided, however, no payment will be made for removing and replacing decorative landscaping required to be replaced due to negligent or unauthorized operations by the Contractor.

The lump sum bid price shall include all of the Contractor's costs of whatsoever nature. The price bid shall include: excavation; removal and replacement of concrete, rock; removal and replacement of plants; disposal of excess excavated materials; topsoil, fertilizer, water, storage and all other related and necessary materials, work and equipment, required to replace the decorative landscaping in accordance with the Contract Documents.

2-24 Remove and Replace Bus Stop

The measurement and payment of this item will be the total number of bus stops to be removed and replaced for construction of the proposed sewer and/or appurtenances; provided, however, no measurement for payment will be made for bus stops removed and/or replaced due to unauthorized operations by the Contractor.

The unit price bid shall include all of the Contractor's costs of whatsoever nature. The price bid shall include: coordination with the Regional Transportation District (RTD); adherence to the rules and procedures set forth by RTD; scheduling all necessary relocates and utility

Measurement and Payment

disconnections/reconnections, as required, to insure that no time is lost on the project; excavation, removal and disposal of materials as necessary; removal, storage, and replacement of poles, signs, benches, shelters, trash cans, guy wires and all other appurtenances associated with the bus stop; installation and removal of temporary bus stops, as required by RTD; removal and replacement of concrete bus pads, pavement, subgrade material, curb, gutter and sidewalk, landscaping materials and all other items required to complete construction of the proposed sewer and/or appurtenance and replace the bus stop in the same or better condition upon completion; and all other related and necessary materials, labor and equipment required to complete the construction in accordance with the Contract Documents.

3-2 Hauling of Contaminated Materials to Denver/Arapahoe Disposal Site (DADS)

The measurement for payment of this item will be the number of tons of contaminated material required to be hauled off to the Denver/Arapahoe Disposal Site for construction of the proposed sewer and/or appurtenances; provided, however, no measurement for payment will be made for hauling of non-contaminated materials and contaminated materials not authorized by the Construction Project Manager. Payment shall be based upon weights obtained from a certified mobile scale, or at a location agreed to with the Construction Project Manager prior to commencement of activities. Certified weight tickets from the agreed to scale shall be used for payment purposes. Payment shall not be made for muck excavation necessary to poor shoring methods or unauthorized operations by the contractor.

The unit price bid per ton of contaminated material disposal shall include all of the Contractor's costs of whatsoever nature. The price bid shall include: excavation; identification, storage, loading; hauling, wrapping and obtaining weights on a certified scale prior to disposal; providing a mobile scale, disposal of debris at the Denver Arapahoe Disposal Site; acquisition of all required permits; all special personnel and equipment required to haul the construction debris to DADS; laboratory testing as required; equipment decontamination; fugitive dust control, containment and monitoring; compliance with Denver Environmental Health – Asbestos-Contaminated Soil Management Standard Operating Procedure (current version); management of on-site treatment; stockpiling, profiling, storage and disposal of contaminated materials; implementation and coordination of Federal, State and Municipal Rules and Regulations as required by the respective agencies and governmental entities; all fees and fines associated and all other related and necessary materials, work, and equipment required for removal of this item in accordance with the Contract Documents.

3-3 Hazardous Waste Disposal

The measurement for payment of this item will be the total number of tons of hazardous waste required to be removed and hauled off, for construction of the proposed sewer and/or appurtenances; provided, however, no measurement for payment will be made for removal and disposals not authorized by the Construction Project Manager. Payment shall be based upon weights obtained from a certified scale agreed to with the Construction Project Manager prior to commencement of activities. Certified weight tickets from the agreed to scale shall be used for payment purposes. Payment shall not be made for muck excavation necessary to poor shoring methods or unauthorized operations by the contractor.

The unit price bid per ton of Hazardous Waste disposal shall include all of the Contractor's costs of whatsoever nature. The price bid shall include: all required permits and fees; excavation, loading, hauling and obtaining weights at a certified scale prior to disposal; and backfilling; disposal of hazardous waste at the Denver Arapahoe Disposal Site; and as required by State and Federal regulations; and all other related and necessary materials, work,

Measurement and Payment

and equipment required for hazardous waste disposal in accordance with the Contract Documents.

3-4 Rock Excavation

The measurement for payment of this item will be the total number of cubic yards of rock required to be removed for construction of the proposed sewer and/or appurtenances; provided, however, no measurement for payment will be made for rock excavation beyond the maximum prescribed trench width or for depths exceeding 12 inches below the pipe nor for excavation due to negligence or unauthorized operations by the Contractor.

The unit price bid per cubic yard of rock excavation shall include all of the Contractor's costs of whatsoever nature required to perform the excavation and to replace the void area with granular bedding and/or any other material specifically approved by the Construction Project Manager. The price bid shall include: excavation, blasting, removal and disposal of rock unsuitable material; furnishing, placing and compacting the approved backfill material required to fill the void area; and all other related and necessary materials, work, and equipment required to excavate the rock in accordance with the Contract Documents.

3-5 Muck Excavation

The measurement and payment for this item will be the total number of tons of muck required to be excavated and disposed of; provided, however, no measurement for payment will be made for any excavation of material that does not meet the definition of muck as described in the technical specifications or as determined by the Construction Project Manager. Measurement for muck excavation will be made only to the limits specifically determined by the Construction Project Manager. Payment shall be based upon weights obtained from a certified scale agreed to with the Construction Project Manager prior to commencement of activities. Certified weight tickets from the agreed to scale shall be used for payment purposes. Payment shall not be made for muck excavation necessary to poor shoring methods or unauthorized operations by the contractor.

The unit price bid per ton of muck removal shall include all of the Contractor's costs of whatsoever nature; The price bid shall include: excavation; loading, hauling and obtaining weights at a certified scale prior to disposal; removal and disposal of muck at the Denver Arapahoe Disposal Site; dewatering; placing and compacting approved select materials in void areas left by the excavation in a timely fashion; and all other related and necessary materials, labor, and equipment required to remove the muck in accordance with the Contract Documents or as directed by the Construction Project Manager.

3-6 Construct, Repair, or Stabilize Embankments

The measurement and payment for this item will be the total number of cubic yards of embankment materials required for construction of the proposed sewer and/or appurtenances; provided, however, no payment will be made for embankment materials not authorized by the Construction Project Manager.

The unit price bid per cubic yard of embankment construction shall include all of the Contractor's costs of whatsoever nature. The price bid shall include: excavation, haul, furnishing and placement of embankment materials, geotextiles, soils, compaction, placement of riprap, concrete, grouting, grading; and all other related and necessary materials, work, and equipment required to construct the embankment in accordance with the Contract Documents.

Measurement and Payment

3-7a Health & Safety Plan

No quantity measurement will be made for any of the work and materials required to accomplish this aspect of the construction project and payment will be based upon the completion of the work in accordance with the Contract Documents.

The lump sum payment for health and safety plans shall include all of the Contractor's costs of whatsoever nature. The lump sum price bid shall include: creation and modification of a Health & Safety Plan, facilities coordination for health and safety; training of all personnel as necessary to perform work; coordination of Federal and Municipal Rules and Regulations as required by the respective agencies and municipalities; all fees, and fines due to non compliance with regulations, monitoring of the health and safety plan; contaminant testing as required; and all other related and necessary materials, work and equipment required to complete this item in accordance with the Contract Documents.

At the option of the Construction Project Manager, monthly percentage payments, based upon Period of Performance, may be paid to the contractor upon satisfactory completion of and/or proper controls submitted in monthly payment applications. At the discretion of the Construction Project Manager, payment may be withheld for any Non-conformance reports issued for failure to comply with the accepted Health & Safety Plan.

3-7b Material Management Plan

No quantity measurement will be made for any of the work and materials required to accomplish this aspect of the construction project and payment will be based upon the completion of the work in accordance with the Contract Documents.

The lump sum payment for materials management plan shall include all of the Contractor's costs of whatsoever nature. The lump sum price bid shall include: creation of and modification of a Material Management Plan; facilities coordination for health and safety; training of all personnel as necessary to perform work; coordination for testing and disposal of materials; waste classification, profiling and manifesting, protecting workers and the public from exposure to contaminants; decontamination procedures for personnel and equipment; fugitive dust control, containment and monitoring; compliance with Denver Environmental Health – Asbestos-Contaminated Soil Management Standard Operating Procedure (current version); management of on-site treatment, storage and disposal; procurement and stockpiling of lined containers; waste classification, profiling and manifesting; protecting workers and the public from exposure to contaminants; Decontamination of anything exposed to contaminated substances; fugitive dust control and containment including monitoring implementation and coordination of Federal, State and Municipal Rules and Regulations as required by the respective agencies and governmental entities; all fees and fines associated with the Material Management Plan; contaminant testing as required; and all other related and necessary materials, work and equipment required to complete this item in accordance with the Contract Documents.

At the option of the Construction Project Manager, monthly percentage payments, based upon Period of Performance, may be paid to the contractor upon satisfactory completion of and/or proper controls submitted in monthly payment applications. At the discretion of the Construction Project Manager, payment may be withheld for any non-conformance reports issued for failure to comply with the accepted Materials Management Plan.

Measurement and Payment

3-8 Unclassified Excavation

5-3b Overexcavation

The accepted quantities will be paid for at the contract unit price for unclassified excavation or overexcavation. The measurement for payment of this item will be the number of cubic yards of material required to be removed for construction, excluding demolition and removal items specified elsewhere. The measurement and payment for overexcavation or unclassified excavation shall be defined based on field conditions (insitu) prior to commencing operations (excavated volumes shall not be allowed) and agreed to by the Construction Project Manager. If feasible, a before and after field survey may be conducted to define this volume. In either method, this area shall be defined as the unclassified or over excavation zone. The quantity paid shall not include any material excavated above the proposed facility subgrade, as shown within the contract documents.

The unit price bid per cubic yard of excavation shall include all of the Contractor's costs of whatsoever nature. The unit price bid shall include: all labor, equipment, materials and incidentals required to excavate the materials, loading, hauling and disposal on-site and off-site to the Denver Arapahoe Disposal Site, and stockpiling of materials; placement as subgrade and/or topsoil elsewhere on site as specified within the contract documents; placement for embankments, water conditioning and compaction to specified limits. Embankment construction will not be measured separately but will be included as a separate unclassified excavation bid item with additional notes.

5-1 Structural Fill

5-2a Subgrade Material (Select Backfill)

5-2b Topsoil

5-4 Crusher Fines

5-5 Recycled Concrete

5-8 Crushed Gravel Base Course (CDOT Class 6 Road Base)

The measurement for payment of this item will be the number of tons of structural fill, subgrade material, topsoil, crusher fines, and/or recycled concrete placed and accepted for construction of the proposed facilities and/or appurtenances. No measurement for payment will be made for materials that are placed without specific written approval of the Construction Project Manager. In addition, no payment will be made for: placement due to poor subgrade preparation, cave-ins, and/or negligent or unauthorized activities by the Contractor. This item shall follow the requirements set forth in Section 5.0 of the Standard Construction Specifications.

All delivery trucks shall be plainly numbered and all records of gross, tare and net weights (determined by use of a certified scale) shall be kept in detail and furnished to the Construction Project Manager upon request. These records will be used for payment purposes, and may be reviewed by the Construction Project Manager at any time.

The unit price bid per ton of classified material shall include all of the Contractor's costs of whatsoever nature. The price bid shall include; excavation and preparation of subgrade; removal and disposal of all unsuitable materials; furnishing of approved materials, transporting, weighing at a certified scale as required for payment placing, addition of water as necessary and compacting the classified material; finish grading; and all other related and necessary materials, work, labor and equipment required to complete the site preparation and placement of the classified material in accordance with the Contract Documents.

Measurement and Payment

5-3a Overexcavation And Replacement With Select Backfill Material

The measurement and payment for this item will be the total number of cubic yards of overexcavation and replacement with select backfill material (and/or stabilization materials consisting of 1-1/2 inch angular aggregate as approved by the Construction Project Manager) required to construct the proposed facilities and/or appurtenances; provided, however, no measurement for payment will be made for overexcavation and replacement required due to negligence or unauthorized activities by the Contractor. The measurement for overexcavation and replacement shall start at the proposed pipe or facility subgrade, extend downward as required to produce a stable sub-base for the proposed infrastructure and extend a maximum trench width as defined in the most recent addition of the Standard Detail drawings or a maximum width agreed to by the Construction Project Manager prior to commencing overexcavation. This area shall be defined as the stabilization zone.

Payment will be solely based on the cubic yards of approved select material imported and installed within the stabilization zone defined above. Separate payment will not be made for the overexcavation under this bid item. Select material must conform to the requirements set forth in Section 5.0 of the Standard Construction Specifications. The Contractor must obtain approved submittals for all select materials used under this item from the Construction Project Manager, to ensure that the material proposed for use meets the field conditions and intended use. All delivery trucks shall be plainly numbered and all records of gross, tare and net weights (determined by use of a certified scale) as well as load volumes and weights shall be kept in detail and furnished to the Construction Project Manager upon request. These records will be used for verification purposes during payment and may be reviewed by the Construction Project Manager at any time. All hauling and disposal of construction or contaminated materials generated due to construction activities must be managed in strict conformance with the Standard Construction Specifications.

The unit price bid per cubic yard of overexcavation and replacement shall include all of the Contractor's costs of whatsoever nature. The unit price bid shall include: trench protection, overexcavation, removal and disposal of material within the stabilization zone, removal and disposal of unsuitable material, hauling and disposal to the Denver Arapahoe Disposal Site (DADS); furnishing and installation of approved select materials, transporting, weighing at a certified scale as required for verification of payment; compaction and installation of approved select materials; dewatering as necessary to allow installation and stabilization of select materials; furnishing and installation of geotextiles or filter fabrics as required in the Contract Documents, and all other related and necessary materials, work, labor and equipment required to complete the removal in accordance with the Contract Documents.

5-7 Controlled Low Strength Material (CLSM)

The measurement and payment for this item will be the total number of cubic yards of Controlled Low Strength Material, controlled density fill, etc. approved for construction of the proposed facilities and/or appurtenances; provided, however, no measurement for payment will be made for materials required due to careless or unauthorized activities by the Contractor.

The unit price bid per cubic yard shall include all of the Contractor's costs of whatsoever nature. The price bid shall include: furnishing and hauling; placement, as directed by the Construction Project Manager; maintaining the mixture to the requirements provided for within the Contract Documents; protection of existing facilities; and all other related and

Measurement and Payment

necessary materials, work, and equipment required to furnish the material in accordance with the Contract Documents.

5-9 Permeation Grouting

The measurement and payment for this item will be per linear foot of tunnel center line that requires permeation grouting, as shown in the plans and/or as approved for construction of the proposed facilities and/or appurtenances. This is a one time, linear foot payment per tunnel, from face of structure to face of structure, no further payment will be made for additional permeation grouting needed or for careless or unauthorized activities by the Contractor.

The unit price bid per linear foot shall include all of the Contractor's costs of whatsoever nature. The price bid shall include and is not limited to: mobilization, demobilization and remobilization of all equipment and materials as necessary to complete the work and/or accommodate access restrictions to property and special requests by property owners; permits, rental fees for offsite storage of equipment and materials; site clearing and construction access necessary for site preparation; dewatering, water control; utility locates and potholing of existing utilities prior to drilling; support of steel casing; removal, transport and disposal of muck; surface monitoring, deep settlement monitoring, surveying, surface pressure tests, monitoring of surface for leakage; design of grout program; development and submittal of a grouting layout plan; installation and removal of sleeve port pipes for grouting operations; supply, mixing, field and lab testing, and installation of chemical grout; monitoring and reporting of grouting operations; clean up and restoration of all surface features effected by grouting operations; abandonment of bore holes; furnishing and hauling; placement, as directed by the Construction Project Manager; maintaining the mixture to the requirements provided for within the Contract Documents; protection of existing facilities; demonstrating the effectiveness of grouting program; additional permeation grouting outside the estimated limits shown in the drawings as necessary for construction and all other related and necessary materials, work, and equipment required to furnish the material in accordance with the Contract Documents.

8-1.1 Dip AWWA C151, Class 50 Water Line

8-1.3 PVC AWWA C900, Class 200 and Class 150 Water Line

8-1.6 PVC AWWA C905 DR18 Water Line

The measurement and payment of each specific size of waterline pipe, except segments as may be otherwise provided for in the Contract Documents, will be the actual number of linear feet of pipe required to be removed and relocated or installed, complete, in place, as measured along the centerline of the waterline pipe from given station to given station, from center of valve to center of valve or from center of manhole to center of manhole with deductions made for the internal diameter or dimensions of manholes, structures and/or valves; provided, however, no measurement for payment will be made for pipe removed or damaged due to negligence or unauthorized operations by the Contractor.

The unit price bid per linear foot for the construction of each section of waterline shall include all of the Contractor's costs of whatsoever nature for the complete construction of the pipeline in accordance with the requirements of the Board of Water Commissioners of Denver. The price bid shall include: furnishing of temporary sanitary facilities, bottled water and coordinating shut off to correspond with non-work hours, including night and weekends if necessary, payment of all associated inspection fees, trench sloping, benching, bracing, shoring and/or sheeting for pipe and associated appurtenances to assure safe working conditions; removal and disposal of the existing conduit and appurtenances (per State and Local

Measurement and Payment

requirements where applicable for lines containing asbestos), including valves, water meter's, stop boxes, fire hydrants, pressure regulating devices, restraints, and fittings; furnishing and installing required waterline pipe, fittings, appurtenances, temporary facilities and blow offs; tapping and/or connecting to mainlines, installing required copper service line pipe or structures; cutting and/or plugging of all abandoned facilities crossed during construction; furnishing and installing special fittings and restraints, including: transitional pipe sections required to properly connect different types of pipe and/or any other special fittings not specifically provided for elsewhere in the Contract Documents; joints and jointing materials, including: grout, mortar, gaskets, seals, bolts, connecting bands, and other miscellaneous items as required to construct the specific pipe section; removal and disposal of pavement, roadway surface materials, concrete flatwork, sod, landscaping, stumps, brush and any other materials encountered prior to excavation; excavation, including exploratory excavation, as required by the Construction Project Manager; over-excavation to remove unsuitable foundation material and replacement with granular or other approved select materials; constructing the specified bedding including the furnishing, placing, and compaction of sand, gravel, rock and controlled low strength materials, as required by the Denver Water Board; supply and installation of protective coatings or wrappings, locate wires and boxes; backfilling to include furnishing, transporting, and placement of any additional suitable backfill material required (except for those classified backfill materials provided for elsewhere in the Contract Documents); compaction and backfilling as specified (no additional or separate payment will be made for excess excavated material used as backfill or select material elsewhere on the project); restoration of ground surface to its original condition; grading and leveling; care and diversion of drainage courses; pumping and provision of facilities for diversion of flows; trench dewatering; protection, adjustment and/or reconnection of aboveground and underground utilities and service connections, replacement of hydrant laterals and assemblies damaged during crossing, reconnection of water services; coordination of gas service and electric relocates; crossing of existing and abandoned utilities; hauling and disposal of construction debris, excess excavated material, damaged materials and contaminated materials at the Denver Arapahoe Disposal Site (DADS), recycle and salvage of materials as necessary; saw cutting and/or rotomilling within mainline (B_f extents) and lateral trench extents prior to excavation; removal and replacement and/or relocation of signs, and pipe bollards; providing for additional traffic control, to include barricades, detours and flagmen unless provided for elsewhere in the Contract Documents; removal and replacement of all traffic signal and/or activated loops; valve operation tests, pipe chlorination, clear water tests, pressure tests, locate wire testing; and all other related and necessary materials, labor and equipment required to construct a complete operable pipeline in accordance with the Contract Documents and in accordance with the Denver Water Board Standards.

In addition to the above, the unit price bid per linear foot for slip lining, bursting, jacking, tunneling, boring and/or micro tunneling shall include the following: installation of jacking, tunneling and/or boring pits and related equipment; launching and access pits; automated spoil transportation systems; hoists; signal systems, safety equipment; sealing materials, grout, sand, casings, skids and end seals as approved by the Construction Project Manager and as required by the Denver Water Board, filling of all annular spaces and any other necessary labor; purchase, delivery and installation of all equipment and materials required to install the pipe segment and/or associated casing per the Contract Documents; heating and butt fusion jointing; removal and replacement of existing waterlines, valves, hydrants, vaults, restraints, sod, seeding, sprinkler systems, trees, bushes, shrubs, bike path, curb, gutter, sidewalk, pavement, asphalt base course, asphalt wearing surface, and any other surface restoration and/or removal/replacement required within the areas impacted due to these operations.

Measurement and Payment

8-1.2 Install Water Valve, Water Meter and Stop Box

The measurement and payment for this item will be the total number of water valves, water meters and stop boxes required to be installed for construction of the proposed sewer and/or appurtenances; provided, however, no measurement for payment will be made for items required to be installed due to negligent or unauthorized operations by the Contractor.

The unit price bid for installation of this item shall include all of the Contractor's costs of whatsoever nature. The price bid shall include: excavation, backfilling and compaction; removal and disposal of the existing water valve, water meter and/or stop box; installing required copper service line or other pipe, installation of the item in accordance with the requirements of the Denver Water Board; supply and installation of all components required to complete the work, including stop(curb) boxes; removal and disposal of pavement and unsuitable material; and all other related and necessary materials, labor, and equipment required for removal and replacement of each item in accordance with the Contract Documents, and in accordance with Denver Water Board Standards.

8-1.4 Temporary Water Main Bypass

The measurement for payment of this item will be the actual number of linear feet from the center of intersection to the center of intersection for the block being bypassed. Every block requiring temporary water main bypass will only be paid once and all work necessary within the block measured shall be included within this item. Only those sections specifically authorized by the Construction Project Manager will be bypassed and measured for payment.

The unit price bid per linear foot for this item shall include all of the Contractor's costs of whatsoever nature. The price bid shall include: furnishing and setting up of all equipment, labor, and materials required to temporarily bypass the existing water main around the facilities being repaired, reconstructed, or constructed to all properties being served within the effected construction areas and as approved by the Construction Project Manager; installation and maintenance of entire temporary water bypass system during the work to ensure uninterrupted service, safe operation and multimodal access by owners; vacuum breakers and inclement weather devices or procedures to protect system; supply of temporary service connections and fire services in accordance with Denver Water requirements; valve operation tests, pipe chlorination, clear water tests, pressure tests and locate wire testing; permits and fees from applicable entities; compaction and backfilling as specified (no additional or separate payment will be made for excess excavated material used as backfill or select material elsewhere on the project); materials testing and quality control; supplying of energy required to operate all bypass equipment; temporary installation of bypass piping under the pavement of cross streets, or raised transitional crossings as may be required per the approved traffic control plan; temporary surfacing; restoration of ground surface to its original condition including removal and replacement of sod, seeding, sprinkler systems, trees, bushes, shrubs, bike path, curb, gutter, sidewalk, pavement (concrete, asphalt base course, asphalt wearing surface, sub grade materials, etc.) and any other surface restoration and/or removal/replacement within the areas impacted due to these operations; removal and replacement of water fixtures, fire hydrants, valves, or any other appurtenances as necessary to permit bypassing; hauling and disposal of construction debris, excess excavated material, damaged materials, unsuitable material and contaminated materials at the Denver Arapahoe

Measurement and Payment

Disposal Site (DADS); and all other related and necessary equipment, work, and materials required to complete the water bypassing as required in the Contract Documents or as directed by the Construction Project Manager.

8-1.5a Lead Service Line Replacement, <2”ID

8-1.5b Lead Service Line Replacement, >2”ID

The measurement for payment of this item will be the actual number of lineal feet of lead water service line removed and replaced as measured from the corporation stop or tee on the water main to the centerline of the external water meter. Lead services shall be replaced with a minimum size copper service line of ¾,” or to a size adequate to supply all the requirements of the property being served in accordance with Denver Water specifications and details. No measurement for payment will be made for lead service line replacement required due to negligence or unauthorized operations by the Contractor.

The unit price bid per lead service line replacement shall include all of the Contractor’s costs of whatsoever nature for the complete removal and replacement of the lead service line in accordance with the requirements of Denver Water, exclusive of appurtenances or items otherwise provided for in the Contract Documents. The price bid shall include: trench sloping, benching, bracing, shoring and/or sheeting for service lines and associated appurtenances to assure safe working conditions; barricades, fencing and signage as necessary to ensure the safety of the public; removal and disposal of the existing lead service line and appurtenances (per State and Local requirements where applicable), including valves, and fittings; furnishing, transporting, and installing required copper service line pipe, fittings, valves, and appurtenances; providing temporary service and facilities as necessary during construction; tapping and/or connecting to mainlines and/or meters; furnishing and installing special fittings for connection to the water meter, not specifically provided for elsewhere in the Contract Documents; gaskets, seals, bolts, connecting bands, and other miscellaneous items as required to construct the service line; saw cutting and/or rotomilling within trench section prior to excavation; removal and disposal of asphalt, millings, roadway surfacing materials, sod, surfacing materials, stumps, brush and unsuitable material prior to excavation; excavation, including exploratory excavation, as required by the Construction Project Manager; over-excavation to remove unsuitable foundation material and replacement with granular or other approved select materials at the specific written approval of the Construction Project Manager; constructing the specified bedding including the furnishing, placing, and compaction of sand, gravel, rock or controlled low strength materials, as required by Denver Water; supply and installation of protective coatings or wrappings, locate wires and boxes; backfilling to include furnishing, transporting, and placement of any additional suitable backfill material required (except for those classified backfill materials provided for elsewhere in the Contract Documents); compaction and backfilling as specified (no additional or separate payment will be made for excess excavated material used as backfill or select material elsewhere on the project); grading and leveling; restoration of ground surface to its original condition including the removal and replacement of sod, seeding, sprinkler systems, trees, bushes, shrubs, bike path, curb, gutter, sidewalk, pavement, asphalt base course, asphalt wearing surface and any other surface restoration and/or removal/replacement required within areas impacted due to these operations; care and diversion of drainage courses; trench dewatering; protection, adjustment and/or reconnection of aboveground and underground utilities; coordination of gas service and electric relocates; crossing of existing and abandoned utilities; hauling and disposal of construction debris, excess excavated material, damaged materials and contaminated materials at the Denver Arapahoe Disposal Site (DADS); removal and replacement and/or relocation of signs, and pipe bollards; providing for additional traffic control, to include barricades, detours and flagmen as specified per the approved MHT/Street Occupancy permit; removal and

Measurement and Payment

replacement of all traffic signal and/or activated loops; valve operation tests, pipe chlorination, clear water tests, pressure tests, locate wire testing; permits and fees from applicable entities; and all other related and necessary materials, labor and equipment required to construct a complete operable water service line in accordance with the Contract Documents and in accordance with Denver Water specifications and standards.

8-2 Remove Fire Hydrant Assembly

The measurement and payment for this item will be the total number of fire hydrants required to be removed for construction of the proposed sewer and/or appurtenances; provided, however, no payment will be made for hydrants replaced due to negligent or unauthorized operations by the Contractor.

The unit price bid for removal of this item shall include all of the Contractor's costs of whatsoever nature. The price bid shall include: excavation; removal and disposal(or recycling as applicable) of hydrant, fittings, restraints, valves and appurtenances; plugging and capping of hydrant service line as required; backfilling and compaction; removal and disposal of pavement and unsuitable material; and all other related materials, work, and equipment required for removal of this item in accordance to the Contract Documents, and in accordance to the Denver Water standards.

8-3 Reset or Install Fire Hydrant Assembly

The measurement and payment for this item will be the total number of fire hydrants required to be reset and/or placed for construction of the proposed sewer and/or appurtenances; provided, however, no payment will be made for hydrants reset and/or installed without authorization by the Construction Project Manager or due to negligent operations of the Contractor.

The unit price bid for this item shall include all of the Contractor's costs of whatsoever nature. The price bid shall include: excavation; furnishing, installation and assembly of all materials including but not limited to: hydrant, risers, fittings, restraints, valves and appurtenances; resetting existing hydrants as permitted; backfilling and compaction; removal and disposal of pavement and unsuitable material; operation tests, chlorination tests, clear water tests, pressure tests, and all other related and necessary materials, work, and equipment required for installation of the fire hydrant assembly in accordance with Denver Water standards.

- 12-1.1 6" Curb and Gutter – 2' Pan (CDOT T2, IIB)**
- 12-1.2 6" Curb and Gutter – 1' Spill Pan (CDOT T2 IB)**
- 12-1.4 9" Curb and Gutter**
- 12-1.5 Combination Curb, Gutter and Sidewalk (2'-8")**
- 12-1.6 Combination Curb, Gutter and Sidewalk (3'-11")**
- 12-1.6a Combination Curb, Gutter and Sidewalk (4'-11")**
- 12-1.7 6" Concrete Curb Head**
- 12-1.8 Handicap Concrete Curb Ramp**
- 12-1.9 Gutter Overlay**
- 12-2.1 Concrete Sidewalk**
- 12-2.2 Reinforced Concrete Sidewalk**

(Continued Next Page)

Measurement and Payment

- 12-2.3 Concrete Bike Path
- 12-2.4 Miscellaneous Concrete Flatwork
- 12-3 Concrete Valley Gutter (all sizes)
- 12-4.1 Concrete Street Intersection Gutter (Crossspan)
- 12-4.2 Concrete Street Intersection Gutter with Slot
- 12-4.3 Special Precast Concrete Intersection Gutter
- 12-5.1 Concrete Driveway Paving
- 12-5.2 Concrete Apron
- 12-5.3 Concrete Bus Pad
- 12-5.4 Concrete Alley Gutters
- 12-5.5 Concrete Alley Paving
- 12-5.6 Concrete Alley Returns
- 12-5.7 Concrete Street Paving
- 12-6 Concrete Median Strip
- 12-8 Concrete Steps

The measurement and payment for installation of this item will be the total number of linear feet for: gutter overlay, curb and gutter, curb head, combination curb gutter and sidewalk, or the total number of square feet for: median strips, sidewalk, bike path, driveway pavement, street paving, crossspans, handicap curb ramps, alley paving, alley gutters, alley returns, single or double flare aprons, bus pads, valley gutter, concrete steps or any other type of miscellaneous concrete flatwork placed and accepted; provided, however, no measurement and payment will be made for flatwork placed due to careless or unauthorized operations by the Contractor.

All concrete ingredients and additives must be combined and mixed at the batch plant prior to transport. Onsite additions to the concrete mix, of any type, will not be allowed without prior authorization of the Construction Project Manager.

The unit price bid per square foot of concrete steps shall be quantified by the width of the stairs multiplied by the summation of each stair hypotenuse (the hypotenuse of the rise and run of each stair). The unit price bid per linear foot or square foot placement of these items shall include all of the Contractor's costs of whatsoever nature. The price bid shall include: sawcutting and/or rotomilling surrounding surface to allow placement, removal of pavement or roadway surfacing; concrete sawing, furnishing and placing the concrete; forming, finishing and curing compounds; contraction and expansion joints where required by Construction Project Manager, including partial depth sawcuts; joint sealing compounds; reinforcing as required and specified; providing high early concrete as necessary to meet specific project needs; concrete additives including, but not limited to: set retarders, accelerators and polypropylene fibrillated fibers as directed and approved by Construction Project Manager; edging the concrete surface; furnishing, transporting, installing and compaction of materials required for a stable sub-base; removal and disposal of unsuitable subgrade materials (including frost), replacement with suitable backfill as necessary; backfilling and pavement around new flatwork; protection from freezing and vandalism; and all other related and necessary materials, work and equipment required to construct this item in accordance with the Contract Documents.

-
- 12-7 Non-reinforced Concrete Median Barrier
 - 12-9 Concrete Headwall
 - 12-10 Concrete Lined Ditches
 - 12-11 Concrete Planters

(Continued Next Page)

Measurement and Payment

- 12-12 Concrete Cradle for Class "A" Bedding**
- 12-13 Concrete Encasement around Pipe**
- 12-14 Concrete Cut-Off Wall**
- 12-16a Concrete Retaining Wall**
- 12-16b Block Retaining Wall**

The measurement for payment of bulk concrete items such as median barriers, cradles, encasements, cut off walls, lined ditches and planters will be the total number of cubic yards of concrete required for construction. The measurement and payment for retaining walls will be a lump sum payment for each wall and type as indicated in the contract documents. The measurement and payment for headwalls will be based upon the actual number required as indicated within the contract documents for construction of the proposed sewer and/or appurtenance. No payment will be made for any of these items replaced due to negligent or unauthorized operations by the Contractor.

The unit price bid per cubic yard, lump sum or each for these items shall include all of the Contractor's costs of whatsoever nature. The price bid shall include: furnishing, transporting, and installing concrete materials, steel reinforcement, add mixtures and fiber reinforcement as required, and block materials; excavation and overexcavation; furnishing, transporting and installing necessary subgrade, bedding and drainage materials, forming and curing compounds; finishing and edging of concrete; winter protection; backfilling and compaction; grinding, patching and finishing of concrete wall surfaces, application of wall finishes as indicated in the contract documents, installation and furnishing of all fence and/or railing noted for individual wall segments; hauling and disposal of construction debris, excess excavated material, damaged materials and contaminated materials to the Denver Arapahoe Disposal Site (DADS); and all other related and necessary materials, work and equipment required to construct this item in accordance with the Contract Documents.

-
- 16-1 Security Fence**
 - 16-2a Single Swing Gate**
 - 16-2b Double Swing Gate**
 - 16-3 Chain Link Fence**
 - 16-4 Wood Fence**
 - 16-5 Single Steel Post Guardrail**
 - 16-6 Single Wood Post Guardrail**
 - 16-7 Permanent Barricades**
 - 16-8 Hand Rail**

The measurement and payment for this item will be the total number of linear feet of security fence with view obscuring material (privacy screen), chain link fence, wood fence, guardrail, hand rail, and permanent barricades or the total number of swing gates required to be placed for construction, as agreed upon by the Construction Project Manager; provided, however, no measurement for payment will be made for fence work required to be placed due to negligence or unauthorized operations by the Contractor.

The unit price bid per lineal foot or per item placement shall include all of the Contractor's costs of whatsoever nature. The price bid shall include: furnishing and placement of new fencing materials to the height specified in the Contract Documents, including rails, posts, pickets, hardware, locks, paints, special treatments, concrete for posts, single swing gates, double swing gates, steel posts for guard rail, guard rail, wood posts; maintenance, relocation and removal of security fencing, hand rails; replacement of electric outlets, security wire (barbed, razor, etc.) and all other related and necessary materials, work and equipment required to construct the fence work in accordance with the Contract Documents.

Measurement and Payment

20-1 Asphalt Temporary Patching

The measurement for payment of this item will be the actual number of square yards per inch of asphalt temporary patching mix placed, complete and in place, after the area has been properly backfilled and compacted, as required for the proposed sewer and/or appurtenances; provided, however, no measurement for payment will be made for asphalt temporary mix placed in areas not specifically approved by the Construction Project Manager, or required due to careless or unauthorized operation by the Contractor.

The asphalt temporary mix may consist of either hot or cold asphaltic surface material. Unless otherwise specified in the Contract Documents, the minimum thickness of asphalt temporary patching mix required is two inches (2”).

The unit price bid per square yard per inch of asphalt temporary patching mix shall include all of the Contractor’s costs of whatsoever nature for the complete construction of the sewer, appurtenances, street or items otherwise indicated within the Contract Documents. The price bid shall include: all preparatory work for placement to grade; disposal of construction debris and unsuitable materials at the Denver/Arapahoe Disposal Site (DADS); street sweeping; removal and disposal of backfill or subgrade materials to the required elevation and preparation for temporary asphalt placement; temporary asphalt material, hauling, rolling, and compaction; maintenance of the temporary patch to include regrading, recompacting, and renewing the material at sufficient intervals of time to ensure a smooth, dust/mud free driving and/or walking surface; temporary striping as required; removal and disposal of temporary asphalt mix prior to permanent asphalt paving operations; and all other related and necessary materials, work and equipment required to furnish and place the asphalt temporary patch in a manner satisfactory to the Construction Project Manager and in accordance with the Contract Documents.

20-2 Asphalt Surface Course

The measurement for payment of this item will be the actual number of square yards per inch of hot mix asphalt surface course, in place, complete, and accepted by the Construction Project Manager, as required for construction of the proposed improvements in accordance with the Contract Documents; provided, however, no measurement for payment will be made for hot mix asphalt surface course placed in areas not specifically approved by the Construction Project Manager, nor required due to careless or unauthorized operation by the Contractor.

Unless otherwise directed by the Construction Project Manager, the hot mix asphalt surface course shall be placed at a minimum of two-inch (2”) thickness and only in the areas indicated within the Contract Documents. This item may be used for work within the trench limits and/or outside the trench limits as indicated within the Contract Documents and as directed by the Construction Project Manager.

The unit price bid per square yard per inch for hot mix asphalt surface course shall include all of the Contractor’s costs of whatsoever nature for the complete construction of the proposed sewer, appurtenances, street or items otherwise indicated within the Contract Documents. The price bid shall include: obtaining all necessary permits and paying any associated fees; additional milling and/or sawcutting of the existing pavement to ensure a smooth and square joint between existing and new pavement; loading, hauling, and disposal of existing asphalt , all related construction debris and unsuitable materials at the Denver/Arapahoe Disposal Site (DADS); recycling of appropriate materials generated during the work; asphalt tack coat; hot mix asphalt, hauling, placing, rolling, and compaction; raising of manhole rings; street sweeping and clean up; traffic control not provided for elsewhere in this Contract Documents; temporary striping as required; QC testing; and all other necessary materials, work, and

Measurement and Payment

equipment required for placement of the hot mix asphalt surface course in a manner satisfactory to the Construction Project Manager and in accordance with the Contract Documents.

20-3 Asphalt Base Course

The measurement for payment of this item will be the actual number of square yards per inch of hot mix asphalt base course, in place, complete, and accepted by the Construction Project Manager, as required for construction of the proposed improvements in accordance with the Contract Documents; provided, however, no measurement for payment will be made for hot mix asphalt base course placed in areas not specifically approved by the Construction Project Manager, nor required due to careless or unauthorized operation by the Contractor.

Unless otherwise directed by the Construction Project Manager, the hot mix asphalt base course paving shall be placed to the depth and only in the areas specified in the Contract Documents. This item may be used for work within the trench limits and/or outside the trench limits as indicated within the Contract Documents and as directed by the Construction Project Manager.

The unit price bid per square yard per inch of hot mix asphalt base course shall include all of the Contractor's costs of whatsoever nature for the complete construction of the proposed sewer, appurtenances, street or items otherwise indicated within the Contract Documents. The price bid shall include: obtaining all necessary permits and paying any associated fees; saw cutting and/or milling the existing pavement smoothly and squarely in a manner satisfactory to the Construction Project Manager to assure a smooth joint (ripping and wheel-cutting is not permitted); loading, hauling, removal and disposal of existing asphalt pavement, unsuitable material and excess excavated material at the Denver/Arapahoe Disposal Site (DADS); subgrade preparation, backfilling and compaction to include furnishing, transporting and placement of any additional suitable backfill material required; recycling of appropriate materials generated during the work; asphalt tack coat; hot mix asphalt, hauling, placing, rolling, and compaction; street sweeping and clean up; traffic control not provided for elsewhere in the Contract Documents; temporary striping as required; QC testing; and all other necessary materials, work, and equipment required for placement of the hot mix asphalt base course in a manner satisfactory to the Construction Project Manager and in accordance with the Contract Documents.

20-4 Asphalt Rotomilling

The measurement for payment of this item will be the actual number of square yards per inch of asphalt or concrete material rotomilled to the depth specified within the Contract Documents or as directed by the Construction Project Manager to complete the proposed street paving. No measurement for payment will be made for asphalt or concrete rotomilled in areas which are not specifically approved by the Construction Project Manager, indicated within the Contract Documents or required due to careless or unauthorized operations by the Contractor.

No measurement for payment will be made under this bid item for rotomilling within the designated pipe trench limits or other miscellaneous areas where sewer, appurtenances or associated flatwork are to be constructed. These costs shall be included in the unit price bid for the related pipe, structures, or appurtenances and are provided for elsewhere in the Contract Documents. This pay item will be used to pay for rotomilling required after installation of the proposed sewer and/or appurtenances for milling on either side of the trench limits prior to placement of the asphalt base and/or surface course, and as specified within the Contract Documents or as directed by the Construction Project Manager.

The unit price bid per square yard per inch of rotomill shall include all of the Contractor's work of whatsoever nature for the complete construction as indicated within the Contract Documents. The price bid shall include: obtaining all necessary permits and paying any

Measurement and Payment

associated fees; loading; hauling, removal and disposal of unsuitable materials, millings and excess excavated material at the Denver/Arapahoe Disposal Site (DADS) or recycling as appropriate; traffic control not provided for elsewhere in the Contract Documents; street sweeping; surface preparation; and all other necessary materials, work, and equipment required for rotomilling in a manner satisfactory to the Construction Project Manager and in accordance with the Contract Documents.

20-5 Asphalt Patch

The measurement for payment of this item will be the actual number of square yards per inch thickness of hot mix asphalt used for asphalt patching purposes, complete, in place and accepted by the Construction Project Manager; provided, however, no measurement for payment will be made for asphalt patching placed in areas not specifically approved by the Construction Project Manager, or required due to careless or unauthorized operations by the Contractor.

This pay item will be used to pay for asphalt material used outside the limits established in Pay Items 20-2 and 20-3. This pay item will be used to pay for replacement of street paving outside the normal specified limits in areas deemed necessary by the Construction Project Manager.

The unit price bid per square yard per inch of thickness of hot mix asphalt patching shall include all of the Contractor's costs of whatsoever nature. The price bid shall include: obtaining all necessary permits; paying any associated fees; saw cutting and/or milling the existing pavement smoothly and squarely in a manner satisfactory to the Construction Project Manager to assure a smooth joint (ripping and wheel-cutting is not permitted); loading, hauling, removal and disposal of existing asphalt pavement, rotomillings, unsuitable material and/or excess excavated material; subgrade preparation, backfilling and compaction of subgrade to include furnishing, transporting and placement of any additional suitable backfill material required; asphaltic tack coat; fresh asphalt hauling, placing, rolling, and compaction; street sweeping and clean up; traffic control not provided for elsewhere in the Contract Documents; temporary striping as required; QC testing; and all other necessary materials, work, and equipment required for placement of the hot mix asphalt trench pavement in a manner satisfactory to the Construction Project Manager and in accordance with the Contract Documents.

20-6 Placement (Only) For Recycled Asphalt

The measurement for payment of this item will be the actual number of square yards per inch thickness of recycled asphalt pavement placed, complete, in place, and accepted by the Construction Project Manager, as required for construction of the proposed sewer and/or appurtenances; provided, however, no measurement for payment will be made for recycled asphalt pavement placed in areas not specifically approved by the Construction Project Manager, or required due to careless or unauthorized operations by the Contractor, or pavement damage caused by the Contractor's equipment or method of operation.

The unit price bid per square yard per inch of recycled asphalt shall include all of the Contractor's costs of whatsoever nature for the complete construction of the proposed sewer, appurtenances, or items otherwise provided for elsewhere in the Contract Documents. The price bid shall include: obtaining all necessary permits and paying all associated fees; saw cutting to achieve a smooth joint; asphalt tack coat; asphalt hauling, placement, rolling, and compaction; disposal of unsuitable material; street sweeping and cleanup; and all necessary materials, work, and equipment required to furnish and place the recycled asphalt pavement smoothly and squarely in a manner satisfactory to the Construction Project Manager in accordance with the Contract Documents.

Measurement and Payment

20-7 Install Asphalt Path

The measurement and payment for this item will be the actual number of square yards per inch thickness of hot mix asphalt placed to the dimensions shown in the Contract Documents or as directed by the Construction Project Manager, complete, in place, accepted, and as required for construction of the proposed sewer and/or appurtenances; provided, however no measurement for payment will be made for asphalt path placed in areas not specifically approved by the Construction Project Manager or required due to careless or unauthorized operations by the Contractor.

The unit price bid per square yard per inch of hot mix asphalt shall include all of the Contractor's costs of whatsoever nature for the complete construction of the proposed sewer, appurtenances, or items otherwise provided for elsewhere in the Contract Documents. The price bid shall include: obtaining all necessary permits and paying all associated fees; saw cutting to achieve a straight joint; weed removal, grubbing, subgrade preparation, removal and disposal of unsuitable material and excess excavated material, placement of select subgrade material as necessary, compaction, installation of weed block fabric; asphalt tack coat; asphalt hauling, placement, rolling, and compaction; permanent stripping as required; disposal of unsuitable material; street sweeping and cleanup; and all necessary materials, work, and equipment required to furnish and place the hot mix asphalt path smoothly and squarely in a manner satisfactory to the Construction Project Manager in accordance with the Contract Documents.

20-8 Asphalt Curb Head

The measurement for payment of this item will be the total number of linear feet of asphalt curb head required to be placed for construction of the proposed sewer and/or appurtenances; provided, however, no measurement for payment for asphalt curb will be made for curb head required to be placed due to negligence or unauthorized operations by the Contractor.

The unit price bid for placement of this item shall include all of the Contractor's costs of whatsoever nature. The price bid shall include: asphalt hauling, placement, rolling, compaction, shaping; excavation, backfilling and compaction; stabilizing the sub base; establishing grade; providing all labor, equipment and materials required to place asphalt curb as required and specified in the Contract Documents; disposal of excess or unsuitable materials including asphalt, concrete, landscaping materials etc; saw cutting, milling; street sweeping and clean up; traffic control not provided for elsewhere in the Contract Documents; asphalt tack coat; replacement and reestablishment of landscaping, sod, seed, irrigation systems and/or any other items impacted during placement of this item; and all other related and necessary materials work and equipment required to place this item in accordance with the Contract Documents or at the direction of the Construction Project Manager.

20-9a Saw Cut Asphalt/Concrete (0-150 LF)

The measurement and payment for saw cutting from 0-150 linear feet will be the actual number of linear feet up to 10-inches of depth of asphalt or concrete that is saw cut and accepted; however, no measurement for payment will be made due to negligent or unauthorized operations by the Contractor.

The unit price bid will be the actual number of linear feet of asphalt or concrete that is saw cut to the full depth and shall include all of the Contractor's costs of whatsoever nature. The unit

Measurement and Payment

price bid shall include but not be limited to: mobilization, traffic control, surface preparation, clean up and disposal of debris, fugitive dust control, slurry removal and protection of storm water inlets; protection of utilities, street cut and occupancy permits, and all other related and necessary materials, work and equipment required to complete the saw cut as directed by the Construction Project Manager and in accordance with the Contract Documents.

20-9b Saw Cut Asphalt/Concrete (>150 LF)

The measurement and payment for saw cutting distances greater than 150 lineal feet will be the actual number of linear feet up to 10-inches of depth of asphalt or concrete that is saw cut and accepted; however, no measurement for payment will be made due to negligent or unauthorized operations by the Contractor.

The unit price bid will be the actual number of linear feet of asphalt or concrete that is saw cut to the full depth and shall include all of the Contractor's costs of whatsoever nature. The unit price bid shall include but not be limited to: mobilization, traffic control, surface preparation, clean up and disposal of debris, fugitive dust control, slurry removal and protection of storm water inlets; protection of utilities, street cut and occupancy permits, and all other related and necessary materials, work and equipment required to complete the saw cut as directed by the Construction Project Manager and in accordance with the Contract Documents.

21-1 Concrete Pavement

The measurement and payment for this item will be the actual number of square feet of concrete placed and accepted; provided, however, no measurement for payment will be made for concrete pavement outside of the prescribed trench width or other dimensions as shown in the Contract Documents. Pavement required to be replaced due to careless or unauthorized operations by the Contractor will not be included in the amount computed for payment.

All concrete ingredients and additives must be combined and mixed at the batch plant prior to transport. Onsite additions, to the concrete mix, of any type will not be allowed without prior authorization of the Construction Project Manager.

The unit price bid per square foot of pavement shall include all of the Contractor's costs of whatsoever nature. The price bid shall include: forming, reinforcing chairs or supports as required by the Construction Project Manager, concrete, reinforcement, doweling; excavation; disposal of unsuitable material; curing compounds; contraction and expansion joints where required by Construction Project Manager, including partial depth sawcuts; joint sealing compounds; reinforcing as required and specified; providing high early concrete as necessary to meet specific project needs; concrete additives including, but not limited to; set retarders, accelerators and polypropylene fibrillated fibers as directed and approved by Construction Project Manager; finishing and edging; furnishing, transporting, installing, and compaction of all materials required for a stable subbase; removal and disposal of excess subgrade materials; QC testing; and all other related and necessary materials, work and equipment required to construct the pavement in accordance with the Contract Documents.

22-1 Earthwork

The measurement and payment for this item will be the total number of square yards of material to be removed and/or filled for construction as shown in the plans. The measurement for payment of this item will be based on the actual surface area within the footprint of the proposed embankment prior to construction activities.

Measurement and Payment

The unit bid price per square yard of earthwork shall include: all labor, equipment, material, subcontractors and incidentals required to perform earthwork as identified within the contract documents; clearing and grubbing; excavation; loading, hauling and disposal of excess excavated material and debris, stockpiling as necessary; hauling, procurement, placement and compaction of embankment materials as required; grading; diversion of water courses and/or dewatering operations as necessary; compaction to specified limits; excavation below the grades shown on plans to remove unsuitable foundation material, replacement of unsuitable foundation materials with suitable select materials; QC testing; and all other materials, work and equipment required to complete the construction in accordance with the contract documents.

27-1 Steel Sheet Piling

The measurement and payment for this item will be the actual number of horizontal lineal feet of steel sheet piling installed, regardless of depth needed, accepted, and left in place (or removed after completion of construction activities) up to one foot above the top of the new sewer pipe and/or appurtenance or the utility being protected. Provided, however, no measurement for payment will be made for steel sheet piling placed due to careless or unauthorized operations by the Contractor.

The unit bid price per linear foot of steel sheet piling shall include all of the Contractor's costs of whatsoever nature. The price bid shall include: placement, excavation, materials, diversion of water courses, welding where required, removal where applicable, backfilling and compaction; cutting of the steel sheeting smoothly and squarely in a manner satisfactory to the Construction Project Manager.

30-1 Riprap

30-2 Grouted Rip Rap

30-2a Grouted Boulders (2-Foot Diameter)

30-2b Grouted Boulders (3-Foot Diameter)

30-2c Grouted Boulders (5-Foot Diameter)

30-2k Boulder (4-Foot Diameter)

30-2l Boulder (5-Foot Diameter)

30-3 Rock Filled Gabions

30-4 Derrick Stone/Riprap Outfall

The measurement for payment of this item will be the total number of square yards of riprap, soil riprap, grouted riprap, grouted boulders and/or derrick stone, or the total number of boulders, or the total number of tons used for rock filled gabions required to be furnished and placed on site for construction of the proposed sewer and/or appurtenances; provided, no measurement for payment will be made for items installed due to careless or unauthorized operations by the Contractor.

The unit price bid per square yard of riprap, soil riprap, grouted riprap, grouted boulders and derrick stone, shall be quantified based on the area of the installed surface directly parallel with the ground. The unit price bid per square yard, per ton, or per boulder shall include: clearing and grubbing; excavation; preparation of bedding/subgrade areas to include over excavation, furnishing, transporting, installing and compaction of all materials required for a stable sub-base and as shown in the details; removal and disposal of excess excavated materials; diversion of water courses and/or dewatering operations as necessary; supply and installation of filter and/or stabilization materials; filter and riprap drains; drain materials; concrete and/or grout; grouting of riprap or boulders; placing of riprap or boulders to the elevations shown on the Contract Documents or as directed by the Construction Project Manager; mattress units and materials for rock filled gabions; overexcavation and replacement

Measurement and Payment

with suitable materials; hauling and placing of all materials; and all other materials, work and equipment required to complete construction in accordance with the Contract Documents.

30-2e 36" Grouted Boulder Edge

30-2f 48" Grouted Boulder Edge

The measurement and payment of this item will be the total linear feet of boulder edge required to be furnished and placed on site for construction of the proposed channel; provided, no measurement for payment will be made for items installed due to careless or unauthorized operations by the Contractor.

The unit price bid per linear foot of boulder edge shall be quantified based on the length of installed boulder along the proposed channel edge. The unit price bid per linear foot of boulder shall include: excavation; preparation of bedding/subgrade areas to include over-excavation as necessary; clearing and grubbing; furnishing, transporting, installing and compaction of all materials (bedding, rip rap, rock, or select fill) required for a stable sub-base and as shown in details; removal and disposal of excess excavated materials; diversion of water courses and/or dewatering operations as necessary placing of boulders to the elevations shown on the Contract Documents or as directed by the Construction Project Manager; grouting of boulders as shown in the details; installation of weep holes as required; hauling and placing of all materials; and all other materials, work and equipment required to complete construction in accordance with the Contract Documents.

34-2 C-76 RCP

34-3 C-361 RCP

34-4 C-506 ARCH Pipe

34-5 C-507 RCP

34-6.1 Box Culvert - Cast-In-Place

34-6.2 Box Culvert - Precast

34-7.1 PVC Pipe

34-7.2 PVC Slipliner Pipe

34-7.3 PVC Pipe with Steel Casing

34-8.1 HDPE SDR 17 Pipe By Bursting (PE 345434E)

34-9.1 ASTM A746 D.I. Pipe

34-10.1 Aluminized Steel Pipe

34-10.4 Steel Casing Pipe BY JACKING/BORING with Centrifugally Cast Concrete Liner

34-11.1 PVC Pipe By Jacking/Boring With Steel Casing

34-11.2 C-76 RCP, Class V By Jacking/Boring, Joint Type R-2

34-11.3 C-361 RCP By Jacking/Boring (see notes for class & cover depth)

34-11.4 HDPE SDR 17 Pipe By Jacking/Boring With Steel Casing (PE 345434E)

34-11.5 C-76 RCP, Class III By Jacking/Boring With Steel Casing

34-11.6 RPMP By Jacking/Boring

34-11.7 C-76 RCP, Class III By Jacking/Boring, Steel Bell Band

34-11.8 C-76 RCP, Class V By Jacking/Boring, Steel Bell Band

34-11.9 RPMP by Open Cut

The measurement and payment of each specific size or type of pipe, except segments as may be otherwise provided for in the Contract Documents, will be the actual number of linear feet of sewer pipe installed, complete, in place, as measured along the centerline of the pipe from inside face of manhole to inside face of manhole, from inside face of manhole to given station,

Measurement and Payment

from given station to given station, or from center of manhole to center of manhole with deductions made for the internal diameter or dimensions of manholes and/or structures. Where special fittings have been specified and provided for elsewhere in the Contract Documents, deductions will be made for their lengths.

The unit price bid per linear foot for the construction of each section of pipeline shall include all of the Contractor's costs of whatsoever nature for the complete construction of the pipeline, exclusive of manholes, appurtenances, or items otherwise provided for in the Contract Documents. The bid item shall include: trench sloping, benching, bracing, shoring and/or sheeting for pipe and associated appurtenances to assure safe working conditions; design of shoring, stamping and approval by an Engineer licensed in the State of Colorado, submittal as required; furnishing, transporting and installing all pipe and materials; tapping and/or connecting to mainline pipes, structures, stub outs or block outs; concrete coring; plugging of all abandoned lines crossed during construction; furnishing and installing special fittings, including: trash racks, concrete pipe plugs as required, transitional pipe sections required to properly connect different classes of pipe without a manhole or structure and any other special fittings not provided for elsewhere in the Contract Documents; joints and jointing materials, including: grout, mortar, fiberglass resin, gaskets, seals, bolts, concrete collars, connecting bands, and other miscellaneous items as required to construct the specific pipe joint per manufacturer and City standards; saw cutting and/or rotomilling within mainline (B_f extents) and lateral trench extents prior to excavation; removal and disposal of pavement, roadway surface materials, concrete flatwork, sod, landscaping, stumps, brush, unsuitable material within the trench width and any other materials encountered prior to excavation; excavation, including exploratory excavation, as required by the Construction Project Manager; over-excavation to remove unsuitable foundation material and replacement with granular or other approved select materials; constructing the specified bedding including the furnishing, placing, and compaction of sand, gravel and rock as required for class B bedding or approved substitution; supply and installation of protective coatings or wrappings; backfilling to include furnishing, transporting, and placement of any additional suitable backfill material required (except for those classified backfill materials provided for elsewhere in the Contract Documents); compaction and backfilling as specified, no additional or separate payment will be made for excess excavated material used as backfill or select material elsewhere on the project; restoration of ground surface to its original condition; grading and leveling; care and diversion of drainage courses; pumping and provision of facilities for diversion of flows; trench dewatering; protection and adjustment of aboveground and underground utilities and service connections or laterals, including water service reconnections and adjustments; sanitary sewer encasement; adjustment and reconnection of sanitary sewer services from mainline sewer to a point where proper connection and drainage can be achieved, unless provided for elsewhere in the Contract Documents; removal and replacement of hydrant laterals and assemblies damaged or relocated during crossing; coordination of gas service and electric relocations; crossing of existing and abandoned utilities; cutting and/or plugging of abandoned or crossed lines where indicated in the Contract Documents, or as directed by the Construction Project Manager; hauling and disposal of construction debris, excess excavated material, damaged materials, unsuitable materials and manifested contaminated materials at the Denver Arapahoe Disposal Site (DADS), recycle and salvage of materials as necessary; removal and replacement and/or relocation of signs, and pipe bollards; providing for additional traffic control, to include barricades, detours and flagmen unless provided for elsewhere in the Contract Documents; removal and replacement of all traffic signal and/or activated loops; QC testing for all associated work components; and all other related and necessary materials, labor and equipment required to construct a complete operable pipeline in accordance with the Contract Documents.

In addition to the above, the unit price bid per linear foot for slip lining, bursting, jacking, tunneling, boring and/or micro tunneling shall include the following: installation of jacking,

Measurement and Payment

tunneling and/or boring pits, intermediate jacking stations, rescue pits and related equipment; launching and access pits; design of bracing/shoring for all pits by an Engineer licensed in the State of Colorado; dewatering and water control; installation and maintenance of pit safety equipment; removal of shaft support systems; utility coordination, locating and potholing within pit and tunnel locations prior to starting construction operations; compensation grouting, all equipment and materials necessary to complete this work, developing and submitting detailed grout programs; installation of grout pipes; monitoring, recording and reporting of grouting operations; associated QC testing; removal of grout pipes after completion of tunneling, subsurface investigation and testing prior to installation; installation, monitoring/recording, maintenance and removal upon completion of surface monitoring points/arrays, deep settlement monitoring points, inclinometers and all related equipment and/or software; steel joint rings on reinforced concrete pipe; automated spoil transportation systems; hoists; fluids and slurries; signal systems, safety equipment; protective joint seals/wraps; sealing materials, joint cushions, reaction thrust blocks, grout, sand, casings, skids and end seals as approved by the Construction Project Manager; filling of all annular spaces after completion of tunnel installation via contact grouting; steel casing pipe and welding to create water tight joints and any other necessary labor, equipment and materials; purchase, delivery and installation of all equipment and materials required to install the pipe segment and/or associated casing per the Contract Documents; heating and butt fusion jointing; within pit locations: removal and replacement of existing waterlines, valves, hydrants, vaults, restraints, sod, seeding, sprinkler systems, trees, bushes, shrubs, bike path, curb, gutter, sidewalk, pavement, asphalt base course, asphalt wearing surface, and any other surface restoration and/or removal/replacement required within the areas impacted due to these operations.

34-12.1 4' Diameter Precast Manhole

34-12.2 5' Diameter Precast Manhole

34-12.3 6' Diameter Precast Manhole

The measurement and payment for manholes shall be the total number of individual manholes, complete, in place required for construction of the proposed sewer and /or appurtenances.

The unit price bid per manhole structure shall include all of the Contractor's costs of whatsoever nature. The price bid shall include: furnishing, transporting and installation of all materials, excavation including overexcavation to remove unsuitable foundation material and replacement with suitable material; sheeting and/or bracing; forming; cast-in-place or precast bases; concrete; steel reinforcement; precast barrel sections, flat tops and cones; brick, mortar, plastic joint sealant and grout; manhole steps, rings, cover, cast iron riser rings as specified by the Construction Project Manager; construction and shaping of the manhole base invert as shown in the standard details, and to incorporate lateral connections and flows into the main channel; water stop gaskets, all boots and bands; cutting and plugging of existing sewer lines as required; reconnection of existing lateral sewer lines to new structure as required, including pipe, couplings and all other materials, equipment and labor required to complete proper reconnection; core drilling into structure as necessary; construction of stub-outs or block-outs; elimination of infiltration; removal and replacement of pavement, base course, sub-base material, sod and other surfacing materials; backfill and compaction; and all other related and necessary materials, work and equipment required to construct the manholes, complete in accordance with the Contract Documents.

34-12.4 Type B Manhole

34-12.5 Type P Manhole

34-12.6 Outfall Structure

34-12.7 Special Structure

Measurement and Payment

The measurement and payment for cast in place manholes and/or structures shall be the total number of manholes or structures, complete, in place, required for construction of the proposed sewer and/or appurtenances.

The unit price bid per manhole and/or structure shall include all of the Contractor's costs of whatsoever nature. The price bid shall include: furnishing, transporting and installation of all materials, excavation (including overexcavation to remove unsuitable foundation material and replacement with suitable material); sheeting and/or bracing; forming; concrete; providing high early concrete as necessary to meet specific project needs; concrete additives including, but not limited to; set retarders, accelerators and polypropylene fibrillated fibers as directed and approved by Construction Project Manager; steel reinforcement; precast barrel sections, flat tops and cones; brick, mortar, plastic joint sealant and grout; manhole rings, covers and cast iron riser rings as specified by the Construction Project Manager; construction and shaping of the manhole base invert as shown in the Standard Construction Specifications, and to incorporate lateral connections and flows into the main channel; beveling and shaping of entrance/exit as required; cutting and plugging of existing sewer lines as required; reconnection of existing lateral sewer lines to new structure as required, including pipe, couplings and all other materials, equipment and labor required to complete proper reconnection; core drilling into structure as necessary; construction of stub-outs or block-outs; construction of waterproof joints; installation of water stop gaskets, boots and bands; elimination of infiltration; removal and replacement of pavement, base course, sub-base material, sod, decorative landscaping and other surfacing materials; backfill and compaction; and all other related and necessary materials, work and equipment required to construct the manholes and/or structures, complete, in accordance with the Contract Documents.

34-12.8 Uncover and Raise (Adjust) Manhole

The measurement and payment for this item will be the number of vertical linear feet of manhole height required to be located, uncovered, and raised for construction of the proposed sewer and/or appurtenances as required in the Contract Documents, by the Construction Project Manager or as determined via video inspection. Payment will be based upon completion of the work to a manner satisfactory to the Construction Project Manager and in accordance with the Contract Documents. No measurement for payment will be made for manhole adjustments required due to negligence or unauthorized operations by the Contractor.

The unit bid for completion of this item shall include all of the Contractor's costs of whatsoever nature. The price bid shall include: locating, including electronic sensing if needed; excavation and overexcavation; removal and disposal of unsuitable material and excess excavated materials; backfill with approved materials; compaction; furnishing and transporting of all materials and equipment; cutting or adjusting of the manhole in a manner satisfactory to the Construction Project Manager; furnishing and placement of concrete, brick, mortar, concrete risers, concrete barrels, flat tops, cones, rings, covers, cast iron risers, plastic joint sealant, grout, manhole steps and all other related and necessary materials, work and equipment required to adjust manholes in accordance with the Contract Documents.

34-12.9 Adjust Utility Lids

The measurement and payment for this item will be the number of utility lids including but not limited to fiber optic, telecommunications, pull boxes, valve boxes, electrical vaults, water vaults, utility manhole lids, etc. required to be uncovered, raised and adjusted to final grade for construction of the proposed sewer and/or appurtenances as required in the Contract Documents, or as required by the Construction Project Manager. Payment will be based upon completion of the work to a manner satisfactory to the Construction Project Manager and in

Measurement and Payment

accordance with the Contract Documents. No measurement for payment will be made for utility lid adjustments required due to negligence or unauthorized operations by the Contractor.

The unit bid for completion of this item shall include all of the Contractor's costs of whatsoever nature. The price bid shall include: locating, including electronic sensing if needed; excavation and overexcavation; removal and disposal of unsuitable material and excess excavated materials; backfill with approved materials; compaction; furnishing and transporting of all materials and equipment; cutting or adjusting of the utility lid in a manner satisfactory to the Construction Project Manager; furnishing and placement of concrete, brick, mortar, concrete and/or cast iron risers, concrete barrels, flat tops, cones, rings, covers, grout, joint sealants, and all other related and necessary materials, work and equipment required to adjust utility lids in accordance with the Contract Documents.

34-13.1 Pipe Outside Drop

The measurement for payment of this item will be the total number of outside sanitary drops of the specified diameter required for construction of the proposed sewer facilities; provided, however, no measurement for payment will be made for outside drops not approved by the Construction Project Manager.

The unit price bid per outside drop shall include all of the Contractor's costs of whatsoever nature. The price bid shall include: pipe and fittings, including additional pipe and/or materials necessary to connect the existing sewer to drop; concrete encasement and reinforcement; excavation and backfill; trench supporting; reshaping of inverts and benches to the top of the highest incoming pipe; reconnection of sidelines; forming and steel reinforcement; and all other related and necessary materials, work and equipment required to construct the outside drop in accordance with the Contract Documents.

34-14.1 RCP Precast Bend

34-14.3 RCP Flared End Section with Trash Rack

34-14.4 Concrete Collars

34-14.5 Flap Gate/Storm Control

The measurement for payment of each specific size or type of special fitting shall be the total number of fittings required for construction of the proposed sewer and/or appurtenances.

The price bid per special fitting shall include all of the contractor's costs of whatsoever nature. The price bid shall include: furnishing, transporting and installing all pipe specials and materials; joints and jointing materials; fasteners and tie downs; pipe collars and closures; bolts, grout, mortar, O-rings, connecting bands; excavation and compaction; shoring and backfilling; removal and disposal of unsuitable material and construction debris; adaptable trash racks for flared end sections; flap gates, assembly and installation; and all other related and necessary materials, work and equipment required to furnish and install these items in accordance with the Contract Documents.

34-15.1 Sewer Tap Location and Verification

The measurement for payment of this item will be the actual number of sewer service connections (sewer taps) required to be located and determined to be active; provided, however, no payment will be made due to negligence or unauthorized operations by the Contractor and

Measurement and Payment

only those sections specifically authorized by the Construction Project Manager shall be measured for payment.

The unit price bid for locating all sewer service connections and verification of active sewer taps shall include all of the Contractor's costs of whatsoever nature for the complete verification and location of each active sewer tap. The price bid shall include: providing 48 hours public notification in advance of the work, furnishing and setting up all equipment required for location and/or verification and digital video and written log documentation of active sewer taps; labor; energy supply required for all equipment; permits and fees; coordination with locators (IUG and/or related utility companies); advance coordination and planning with facility owner to ensure access to mainline sewer; location (vertically and horizontally) and verification of active and capped sewer taps by digging, vacuuming, sensing, electronic locators, televising, dye testing, smoke tracing, and/or any other means necessary to ensure tap location, verification and adequate elevation for connection to sewer main per the Contract Documents; excavation, backfill, compaction; temporary and/or permanent paving; removal and replacement of curb, gutter, sidewalk, sod, sprinkler lines, etc. damaged during location and verification; removal and disposal of unsuitable material and construction debris; and all other related and necessary materials, work, and equipment required to complete this item in accordance with the Contract Documents.

34-15.2 Reconnect Sanitary Sewer Services (Open Cut)

The measurement and payment for each service connection, reconnection and/or adjustment shall be the total number of connections, reconnections and/or adjustments required for construction of the proposed sewer and/or appurtenance.

The price bid for this item of work shall include all of the Contractor's costs of whatsoever nature. The price bid shall include; locating and verifying of service connections unless provided for elsewhere in the Contract Documents; furnishing and installing all pipe, fittings and materials; disconnecting/reconnecting and plugging existing services; plugging all necessary lines; construction of new services from mainline sewer to a point where proper connection and drainage can be achieved; chasing sewer taps from point of crossing or conflict with mainline to a point where proper relocation/reconnection can be attained; removal and replacement of sod, curb, gutter, and pavement outside mainline trench extents and all other surface items within affected areas; crossing of existing and abandoned facilities; excavation and backfill; bedding and compaction; temporary bypass pumping; extension of building sewers where required; loading, hauling and disposal of construction debris, excess excavated material, and contaminated materials at the Denver Arapahoe Disposal Site (DADS); and all other related and necessary materials, work, and equipment required to construct the service connection or reconnection in accordance with the Contract Documents.

34-15.3 Utility Exploratory Investigation

The measurement for payment of this item will be the actual number of field locations or verifications required for construction of the proposed sewer and/or appurtenances as required in the Contract Documents, or as directed by the Construction Project Manager.

The unit price bid per location or verification shall include all of the Contractor's costs of whatsoever nature. The price bid shall include: mobilization and furnishing of all equipment required for location or verification of storm, sanitary or any other utility; acquisition of all permits; coordinating and scheduling the work with appropriate locating entities; coordination of this component of the work in a manner that ensures completion of the overall project per the critical path schedule and in accordance with the contract documents, excavation and backfill, including Controlled Low Strength Materials as required; paving, patching and compaction; location of the utility by digging, vacuuming, sensing, or employment of other

Measurement and Payment

methods in utility location and/or verification; and all other related and necessary materials, work, and equipment required for location or verification of the sewer or utility as required in the Contract Documents or as directed by the Construction Project Manager.

34-16.1 #14 Inlet

34-16.2 Single #16 Inlet

34-16.3 Double #16 Inlet

34-16.4 Triple #16 Inlet

34-16.5 Parking Lot Trench Drain

The measurement for payment of each specific size and/or type of inlet will be the individual structure, complete, in place in accordance with the Contract Documents.

The unit price bid per inlet structure shall include all of the Contractor's costs of whatsoever nature. The price bid shall include: furnishing, transporting, and installing all materials; excavation, including overexcavation to remove unsuitable foundation materials; concrete, pipe collars, reinforcement steel, mortar and grout; manhole lids, rings, covers, grates, frames and curb boxes; open throat construction; galvanized steel rods; manhole steps; concrete ribbed deflectors; backfilling and compaction; removal and replacement of pavement, base coarse, sub-base materials, sod, decorative landscaping and any other surfacing materials; constructing and shaping of the base and invert; replacement of curb, gutter and sidewalk between the transitions as stipulated on the Details; and all other related and necessary materials, work, and equipment required to construct the storm inlet in accordance with the Contract Documents.

34-16.8 Adjust Existing Inlet Structure

The measurement and payment for this bid item will be the actual number of existing inlet structures (excluding flagstone curb head) adjusted. Payment will be based upon completion of the work to a manner satisfactory to the Construction Project Manager and in accordance with the Contract Documents. No measurement for payment will be made for existing inlet structure adjustments due to negligence or unauthorized operations by the Contractor.

The unit price bid will be the actual number of existing inlet structures (Inlet Grates, Frames, Beams, Curb Boxes, etc.), excluding flagstone curb head, adjusted. The unit price bid will include but shall not be limited to: mobilization; raising, lowering, moving, adding and/or removing of concrete, masonry, brick, mortar, concrete risers, inlet grates, plastic joint sealant, grout and all other related and necessary materials, work and equipment required to adjust inlet structures in accordance with the Contract Document; resetting of grates; replacement of curb, gutter and sidewalk between the inlet transitions as stipulated in the Details; traffic control; surface preparation and compaction as necessary; obtaining of a street occupancy permits and street cut permits; locating, including electronic sensing if needed; removal and disposal of construction debris; furnishing and transporting of all materials and equipment; and all other related and necessary materials, work and equipment required for the adjustment of the existing inlet structure.

34-17.1 Pre-Video Inspection of Sewer Pipe

34-17.2 Cleaning of Sanitary Sewer Pipe

34-18.2 Cleaning of Storm Sewer Pipe

The measurement for payment of this item will be the actual number of linear feet of sewer line cleaned and/or pre-video inspected and documented on the log sheet as measured along the centerline of the pipe from center of manhole to center of manhole with deductions made for the diameter of structures and appurtenances. Only those sections specifically authorized by

Measurement and Payment

the Construction Project Manager or noted in the Contract Documents will be measured for payment.

The unit price bid per linear foot of sewer line cleaning and/or pre-video inspection shall include all of the Contractor's costs of whatsoever nature. The price bid shall include: providing 48 hours public notification in advance of the work furnishing and setting up of all equipment, labor, and materials necessary to clean and perform pre-video inspection of the sewer, including an intrinsically safe camera, as necessary; recording all information on USB Plug and Play device (flash drive or hard drive) for review by City; submittal of video in MP4 format and logs in .pdf format, both of which must be submitted in accordance to the naming convention required within the applicable Standard Construction specification section; Identification and locating of all active and inactive (capped) sewer taps, to include linear footage from center upstream manhole, by dye testing, electronic sensing, smoke tracing or use of any other means necessary to verify the active taps; determination of taps requiring trimming; locating, identifying and reporting structurally deficient pipe sections for replacement or point repair; completion of additional pre-installation inspections and sewer cleaning as necessary prior to CIPP installation; supply energy for all equipment; obtain permits for the inspection and covering any related fees; furnishing and setting up all equipment and labor necessary to clean the sewer; furnishing of water for jetting; removal of all foreign material from the sewer line that will prevent installation of cured in place products; all inspection and cleaning of manholes; by-pass pumping and/or diversion of sewer flows around the section of pipe to be cleaned and to another sewer line accepted by the Construction Project Manager to receive such bypass; temporary installation of bypass piping under the pavement of cross streets, or raised transitional crossings as may be required per the approved traffic control plan; repaving of street cuts after completion of bypassing; removal and replacement of manhole rings, covers, steps and cone sections as necessary to permit bypassing; storage of cleaning sediment on the job site in containers or other approved methods; maintaining storage during the waiting time for laboratory test results on the sediment; disposal of sediment according to Local, Federal, and State environmental requirements; removal and disposal of unsuitable material and construction debris; and all other related and necessary equipment, work, and materials required to accomplish this item in accordance with the Contract Documents.

34-17.3 Sanitary Sewer By-Pass

34-18.3 Storm Sewer By-Pass

The measurement for payment of this item will be the number of linear feet of sewer line as measured along the centerline of the pipe run, where the work (ie: lining, repairing or replacing) is occurring from center of upstream manhole to center of downstream manhole and shall only be paid for once during the time necessary to complete each section of work. Bypass plans shall be submitted by the Contractor to the Construction Project Manager for review and shall include written by-pass pumping plans on the approved MHT map for the proposed bypass pumping segment, including plans for contingency activities in the event of weather changes, equipment malfunction, or other disruptions. Bypass plans shall include providing a 48 hour public notification in advance of the work. Only those sections specifically identified within the contract documents or authorized by the Construction Project Manager will be bypassed and measured for payment. All by-pass activities will be performed using materials and methods that result in a complete system that provides zero leakage during all components of by-pass operations.

The unit price bid per linear foot for this item shall include all of the Contractor's costs of whatsoever nature. The price bid shall include: furnishing and setting up of all equipment, labor, measurement and determination of sewer flow, all materials required to pump or divert sewer flows around the section of pipe or manhole being lined, repaired, reconstructed, or

Measurement and Payment

constructed to another sewer line accepted by the Construction Project Manager to receive such bypass; supplying of energy required to operate all bypass equipment; temporary installation of bypass piping under the pavement of cross streets, or raised transitional crossings as may be required per the approved traffic control plan; repaving of streets after completion of bypassing; removal and replacement of manhole rings, covers, steps and cone sections as necessary to permit bypassing; cleanup and removal of unsuitable material; and all other related and necessary equipment, work, and materials required to complete the bypassing as required in the Contract Documents or as directed by the Construction Project Manager.

34-17.4 Cured-in-Place-Pipe

The measurement for payment of this item will be the actual number of linear feet of cured-in-place pipe installed, measured along the centerline of the pipe from center of manhole to center of manhole. Only those sections specifically authorized by the Project Manager or noted in the Contract Documents will be measured for payment.

The unit price bid per linear foot of the Cured-In-Place-Pipe shall include all of the Contractor's costs of whatsoever nature. The price bid shall include, but is not limited to: providing 48 hours public notification in advance of the work, furnishing all equipment, materials, and labor necessary to complete CIPP installation; furnishing and setting up of all equipment, labor, and materials required to pump or divert sewer flows around the section of pipe being lined to another sewer line accepted by the Construction Project Manager to receive such bypass; supplying of energy required to operate all bypass equipment; temporary installation of bypass piping under the pavement of cross streets, or raised transitional crossings as may be required per the approved traffic control plan; repaving of streets after completion of bypassing; removal and replacement of manhole rings, covers, steps and cone sections as necessary to permit bypassing; cleanup and removal of unsuitable material; all other related and necessary materials, work, and equipment required to complete by pass; post-installation inspection video and engineering inspections of the sewer being rehabilitated; use of intrinsically safe equipment as necessary; recording all information on USB Plug and Play device (flash drive or hard drive) for review by City; submittal of video in MP4 format and logs in .pdf format, both of which must be submitted in accordance to the naming convention required within the applicable Standard Construction specification section; Identification and locating of all active and inactive (capped) sewer taps, to include linear footage from center upstream manhole, by dye testing, electronic sensing, smoke tracing or use of any other means necessary to verify the active taps; completion and submittal of written logs and digital as-constructed drawings; determination of taps requiring trimming; locating, identifying and reporting structurally deficient pipe sections for replacement or point repair, completion of additional pre-installation inspections and sewer cleaning as necessary prior to CIPP installation; supply energy for all equipment; obtain all required permits for CIPP installation, materials used, the inspection and covering any related fees; furnishing and setting up all equipment and labor necessary to: clean the sewer; furnish water for jetting, perform bypass pumping required to install product; providing power for de-rooting equipment and other types of machinery; removal and disposal of all foreign material from the sewer line that will prevent installation of cured in place linings; storage of cleaning sediment on the job site in containers or other approved methods; maintaining storage during the waiting time for laboratory test results on the sediment; disposal of sediment according to Local, Federal, and State environmental requirements; all public information and notifications; attending the weekly construction meeting and any other meeting required by the Project Manager; all inspection and cleaning of manholes; removal and disposal of unsuitable material and construction debris; furnishing and setting up all equipment, materials, and labor necessary for the construction process; furnishing water, steam and energy required for the rehabilitation

Measurement and Payment

process; furnishing, installing and applying the Cured-In-Place-Pipe Material; curing the CIPP liner, cutting, trimming and brushing active sewer service connection; hydrophilic water swelling material as needed to prevent infiltration between the CIPP liner and host pipe at each manhole; providing access to the City and County of Denver, or their designee, for the purpose of obtaining samples of installed material for onsite and laboratory testing; incidentals referenced in other sections of the Specifications; and all other related and necessary materials, work, and equipment required to complete this item in accordance with the Contract Documents.

34-17.5 Grinding

The measurement for payment of this item will be the actual number of linear feet of sewer line submitted and approved by the Project Manager. It shall be the Contractor's responsibility to notify the Project Manager of pipe segments that require grinding to facilitate CIPP installation. Only those sections specifically designated by the Construction Project Manager will be ground and measured for payment. Payment for grinding will not be made due to negligence or unauthorized operations by the Contractor.

The unit price bid per linear feet of sewer line grinding shall include all of the Contractor's costs of whatsoever nature. The price bid shall include: providing 48 hours public notification in advance of the work, providing pre and post digital verification video of the specific pipe segments proposed for grinding, removal of roots, protruding objects, chemical deposits, unsuitable material or any other materials as directed by the Construction Project Manager prior to placement of any liner; grinding via mechanical, chemical or other approved methods; furnishing and setting up of all equipment and labor necessary to inspect the line to be rehabilitated; video inspection of the line to locate and identify live sewer taps and to locate taps that require trimming; recording of the video inspection; removal of all materials from the pipe walls that will prevent the proper installation of cured-in-place or formed-in-place plastic liners; furnishing of water and power for de-rooting equipment; storing of cleaning sediments on the job site in containers or other Federal or locally approved storage methods; maintaining of stored materials during the time required to obtain laboratory tests; transporting of the sediment for disposal to a landfill upon receipt of laboratory tests results showing that all tests meet Federal and local standards for normal disposal, payment of disposal and landfill fees, if the material is being hauled to any site other than Denver/Arapahoe Disposal Site (DADS); cleaning and inspection of manholes; and all other related and necessary materials, work and equipment required to complete this item in accordance with the Contract Documents.

34-17.6a Sanitary Sewer Service Reactivation for CIPP

34-17.6b Storm Sewer Service Reactivation for CIPP

The measurement for payment of this item will be the actual number of sewer service taps required to be reactivated as determined to be active during the pre-video inspection study. No measurement for payment will be made for taps which are opened/reactivated and have not been determined to be active. The Contractor shall accept all responsibility to provide residents, businesses, etc. with an established and reconnected sewer service. No measurement will be made for sewer service reactivations due to negligent or unauthorized operations by the Contractor.

The unit price bid shall include all of the Contractor's costs of whatsoever nature. The price bid shall include: furnishing and setting up of all equipment and labor necessary to locate and reactivate active services; cutting and brushing of CIPP material and linings, coatings and/or

Measurement and Payment

coverings required to open active sewer services; removal and disposal of all unsuitable material; providing 48 hours public notification in advance of the work and notifying residents and business upon reactivation; and all other related and necessary materials, work and equipment required to complete this item in accordance with the Contract Documents or at the direction of the Construction Project Manager.

34-17.7 Extended Tap Cutting

The measurement and payment for this item will be the actual number of submitted and approved extended taps or services that would have to be cut or otherwise repaired for construction of the proposed sewer and or appurtenances. No measurement will be made for extended tap cutting required due to negligent or unauthorized operations by the Contractor.

The unit price bid shall include all of the Contractor's costs of whatsoever nature. The price bid shall include: furnishing of all equipment and labor required to cut the extended tap; cutting of the tap to a smooth and hydraulically functional opening; furnishing of power for all equipment; video-inspection and locating of the extended tap; removal and disposal of materials; and all other related and necessary materials, work and equipment required to complete this item in accordance with the Contract Documents or at the direction of the Construction Project Manager.

34-17.8 Intrinsically Safe Electrical Equipment

No measurement for payment will be made for any of the work and materials required to accomplish this aspect of the construction project and payment will be based upon the completion of the work in accordance with the Contract Documents.

The areas/extents within the Contract Documents requiring the use of explosion proof equipment shall be determined by the Contractor. Damage and repair to the sanitary system and surrounding areas due to misuse of equipment, faulty equipment or negligence are the responsibility of the Contractor.

The lump sum price bid for Intrinsically Safe Electrical Equipment shall include all of the Contractor's costs of whatsoever nature. The lump sum price bid shall include: furnishing, installing, and activating the camera; all labor of whatsoever nature to the various areas of construction, and all other related and necessary materials, work, and equipment required to accomplish this item in a manner satisfactory to the Construction Project Manager and in accordance with the Contract Documents.

36-1 Install Railroad Tracks

The measurement for payment of this item will be the actual number of linear feet of railroad tracks constructed, including appurtenances, as shown within the contract documents; provided, however, no payment will be made for track installation outside the project limits or for track installation due to negligence or unauthorized operations by the Contractor. Payment will be based upon each pair of tracks constructed, as measured along the centerline of the newly installed tracks.

The unit price bid per pair of railroad tracks shall include all of the Contractor's costs of whatsoever nature. The linear foot price bid per pair of railroad tracks shall include: all work and materials required to install the tracks per the Governing Railroad Company, contract documents and design criteria; procurement, including protection and stockpiling of materials removed and approved for re-use, hauling, delivery and installation of ballast; track hardening; railroad ties; pre-stressed concrete panels; full depth asphalt or concrete paving up to the concrete panels as delineated by the area perpendicular to the length of tracks being

Measurement and Payment

replaced and within 25 feet of the centerline of the tracks on each side; joining of rails; fasteners, spikes, special joints; grading the subgrade and special bedding under the tracks; hauling and disposal of all excavated material which is not recyclable to the Denver Arapahoe Disposal site; backfilling and compaction; and all other related and necessary materials, work and equipment required for the installation of this item in accordance with the Contract Documents.

40-1 Seeding and Mulching

The measurement and payment for this item will be the total number of square feet of seed, mulch and required soil amendment placed for construction of the proposed sewer and or appurtenances; however, no measurement will be made for seed and mulch placed due to negligent or unauthorized operations by the Contractor.

The unit price bid per square foot of seed and mulch placed shall include all of the Contractor's costs of whatsoever nature. The price bid shall include: furnishing, transporting and placing of seed, mulch, erosion control fabric, blankets or protective coverings; protection and care of stockpiled seed and mulch; preparation, fertilization and soil amendment; furnishing of new seed and mulch of like quality to replace any improperly maintained seed and mulch; watering, raking and rolling the ground surface after placement of seed and mulch; placement of erosion blanket on all slopes greater than 3:1; and all other related and necessary materials, work and equipment required to furnish and place the seed and mulch, complete, in accordance with the Contract Documents.

40-2 Seeding

The measurement and payment for this item will be the total number of square feet of seed to be placed for construction of the proposed sewer and/or appurtenances; however, no measurement for payment will be made for seeding required due to negligent or unauthorized operations by the Contractor.

The unit per square foot of seed placed shall include all of the Contractor's costs of whatsoever nature. The price bid shall include: preparation of soils, ripping and tilling, cleaning, fertilization, leveling to the elevations specified in the Contract Documents; furnishing of seed as specified in the Contract Documents; placing of the seed, wetting, and compaction; erosion control fabric, blankets, or protective coverings as required; watering; reseeding and/or replacement of any improperly maintained seed; and all other related and necessary materials, work, and equipment required to place the seed in accordance with the Contract Documents.

40-3 Sodding

The measurement and payment for this item will be the total number of square feet of sod required to be placed for construction of the proposed sewer and/or appurtenances; provided, however no measurement will be made for sod placed due to negligent or unauthorized operations by the Contractor.

The unit price bid per square foot shall include all of the Contractor's costs of whatsoever nature. The price bid shall include: preparation and cleaning of the ground surface; furnishing of sod as specified in the Contract Documents or to the same quality as the existing sod; replacement of any improperly maintained sod; proper placement of the sod; watering, rolling and compaction; clean up and disposal of unsuitable material; and all other related and necessary materials, work and equipment required to place the sod in accordance with the Contract Documents.

Measurement and Payment

40-4a Install Sprinkler Line

40-4b Relocate Existing Sprinkler Line

The measurement and payment for this item will be the total number of linear feet of sprinkler line required to be installed or relocated for construction of the proposed sewer and/or appurtenances; provided, however no measurement will be made for sprinkler placed due to negligent or unauthorized operations by the Contractor.

The unit price bid shall include all of the Contractor's costs of whatsoever nature. The price bid shall include: excavation, furnishing of materials, protection and installing pipework and heads; adjusting heads; fittings and connections; backfilling, grading, installing and adjusting valves; and all other related and necessary materials, work, and equipment required to install the sprinkler system in accordance with the Contract Documents or as directed by the Construction Project Manager.

40-5 Install or Relocate Sprinkler System

No quantity measurement will be made for any of the work and materials required to install and/or relocate sprinkler systems. Payment will be based upon completion of the work in accordance with the Contract Documents; provided, however, no payment will be made for installing and/or relocating sprinkler systems due to negligent or unauthorized operations by the Contractor.

The lump sum bid price shall include all of the Contractor's costs of whatsoever nature. The price bid shall include: excavation, furnishing and installation of all sprinkler system materials and materials necessary for relocation of an existing system; protection and installing pipework and heads; adjusting heads; fittings and connections; backfilling, grading, installing and adjusting valves; trace wires; electrical hookups, valve boxes and controls; pressure testing of system; winterization and recharging of system as necessary during project period of performance; and all other related and necessary materials, work, and equipment required to install and/or relocate the sprinkler system in accordance with the Contract Documents or as directed by the Construction Project Manager.

40-6 Decorative Landscaping

No quantity measurement will be made for any of the work and materials required to remove and replace this item. Payment will be based upon completion of the work in accordance with the Contract Documents; provided, however, no payment will be made for removing and replacing decorative landscaping required to be replaced due to negligent or unauthorized operations by the Contractor.

The lump sum bid price shall include all of the Contractor's costs of whatsoever nature. The price bid shall include: excavation; removal and replacement of concrete, rock; removal and replacement of plants, mulch, support systems and retaining structures; disposal of excess excavated materials; topsoil, fertilizer, water, storage and all other related and necessary materials, work and equipment, required to replace the decorative landscaping in accordance with the Contract Documents.

Measurement and Payment

40-7 Remove Trees (>6" Diameter)

40-8 Remove Bushes

The measurement for payment of this item will be the total number of trees, bushes, shrubs or landscaping units, required to be removed for construction of the proposed sewer as specified in the Contract Documents and directed by the Construction Project Manager; provided, however, no measurement for payment will be made for items removed which are less than six (6) inches in diameter at a height of one (1) foot above the existing ground.

The unit price bid per tree, bush, shrub or specified landscaping item removal shall include all of the Contractor's costs of whatsoever nature. The price bid shall include: removal of a sufficient length of the root system to insure that the tree, bush, shrub or landscaping unit will not continue to grow; disposal of all materials removed; acquisition of all permits required for removal; backfilling with soil material approved by the Construction Project Manager; and all other related and necessary materials, work and equipment required to remove trees in accordance with the Contract Documents.

40-9 Remove and Transplant Trees (>6" Diameter)

40-10 Replace Bushes and/or Shrubs

The measurement for payment of this item will be the total number of trees required to be removed and transplanted and/or the total number of shrubs and/or bushes required to be replaced for construction of the proposed sewer; provided, however, no measurement for payment will be made for trees required to be removed and transplanted, or shrubs and/or bushes required to be replaced due to negligent or unauthorized operations by the Contractor.

The unit price bid per tree removal and transplant or shrub and/or bush replacement shall include all of the Contractor's costs of whatsoever nature. The price bid shall include: removal, storing, planting, replanting or replacing, puddling, backfilling, and all other related and necessary materials, work and equipment required to remove and transplant the tree or replace the shrub and/or bush in accordance with the Contract Documents.

40-11 Replace Green Ash Tree (2" Caliper)

40-12 Replace Tree (>6" Diameter)

The measurement for payment for tree planting or replanting will be the total number of trees required to be placed per plans and due to construction of the proposed sewer; provided, however, no measurement for payment will be made for trees planted due to negligent or unauthorized operations by the Contractor.

The unit price bid per tree placement or replacement shall include all of the Contractor's costs of whatsoever nature. The price bid shall include: removal, storing, replanting or replacing, backfilling, staking and supporting devices; formed wells and/or cages; insulating wrap; protection from animals; watering and care throughout the warranty period; and all other related and necessary materials, work and equipment required to plant and replant the tree in accordance with the Contract Documents.

40-13 Shade Trees (> 2" Caliper)

40-14 Ornamental Trees (> 2" Caliper)

The measurement for payment for tree planting will be the total number of trees required to be placed per plans and due to construction of the work; provided, however, no measurement for payment will be made for trees planted due to negligent or unauthorized operations by the Contractor.

Measurement and Payment

The unit price bid per tree placement shall include all of the Contractor's costs of whatsoever nature. The price bid shall include: delivery, temporary protection, storage, planting, backfilling, staking and temporary support devices; formed wells and/or cages; insulating wrap; protection from animals; watering and care throughout the warranty period; and all other related and necessary materials, work and equipment required to plant the tree in accordance with the Contract Documents.

40-15 Landscape Improvements

No quantity measurement will be made for any of the work and materials required for this item in construction of the proposed landscape and irrigation improvements. Payment will be based upon completion of the work in accordance with the Contract Documents; provided, however, no payment will be made for any work performed due to negligent or unauthorized operations by the Contractor.

The lump sum bid price shall include all of the Contractor's costs of whatsoever nature. The price bid shall include all of the work and equipment, and all other related and necessary materials, required to construct all of the proposed landscape and irrigation improvements shown on the landscape/irrigation plans, in accordance with the Contract Documents.

41-1 Traffic Control

No quantity measurement will be made for any of the work and materials required to accomplish this aspect of the construction project and payment will be based upon the completion of the work in accordance with the Contract Documents.

The lump sum price for Traffic Control shall include all of the Contractor's costs of whatsoever nature. The lump sum bid price shall include: All coordination with relevant agencies and utility companies; including by-pass pumping plans on the MHT plans submitted to City and County of Denver- Public Works Right of Way Services; furnishing, installing, moving, maintaining and removing all temporary traffic signs, barricades, channeling devices, warning lights, delineators, and any other equipment or personnel as required by the latest revision of the "Manual on Uniform Traffic Control Devices for Streets and Highways", and the requirements set forth by the City and County of Denver, Transportation Engineering Division; all signs, emergency replacements, warning lights, variable message boards, traffic cones, and barricades; approved traffic maintenance plans as required; concrete median barriers as required; lane markings and temporary striping; flagging and notification of property owners; traffic control management; furnishing, installing, adjusting, maintaining and removing all special signs required to direct pedestrians and/or vehicles to businesses or parking facilities disrupted due to construction activities; additional traffic control and safety devices as required by the Construction Project Manager; and all other related and necessary materials, work, and equipment required to accomplish this item in accordance with the Contract Documents.

At the option of the Construction Project Manager payment will be made in percentage installments based upon type, location and scope of work in relation to the period of performance.

41-2 Rerouting and Construction of Bike Path

No quantity measurement will be made for any of the work and materials required to accomplish this aspect of the construction project and payment will be based upon the completion of the work in accordance with the Contract Documents.

Measurement and Payment

The lump sum price bid for rerouting and construction of bike paths shall include all of the Contractor's costs of whatsoever nature. The price bid shall include: furnishing, installing, moving, maintaining and removing all temporary traffic signs, barricades, channelization devices, warning lights, delineators, bike path signage and any other equipment or personnel required for safe conductance and detouring of bike path personnel off and around the designated construction zone in a safe and professional manner; construction of safety fence, including placement of concrete barriers; coordination with Parks and/or Traffic personnel; obtaining of necessary permits and paying associated fees; water control; placement of rock or pavement for temporary bike path; and all other related and necessary materials, work, and equipment required to accomplish this item in accordance with the Contract Documents or the direction of the Construction Project Manager.

At the option of the Construction Project Manager, one third of the lump sum price for this item may be paid to the Contractor upon satisfactory completion of and/or incorporation of proper controls, the second third may be paid upon fifty percent completion of the work as determined by the percent of work completed on the day of progress payment, and the last third may be paid to the Contractor at the last progress payment or at the discretion of the Construction Project Manager.

42-1 Railroad Control

No measurement will be made for any of the work and materials required to accomplish this aspect of the construction project and payment will be based upon the percent completion of the work in accordance with the Contract Documents.

The City and County of Denver (railroad Licensee) will obtain all necessary license agreements. The contractor(agent of Licensee including subcontractors, officers, agents and employees; and others acting under the licensee or agent of licensee's authority) will be responsible for the acquisition and maintenance of all railroad protective liability insurance as required by the railroad crossing agreements included within the bid document package, and which is deemed necessary by the railroad to complete construction. In no way should the railroad pipeline crossing agreement be used to dictate railroad flagger/inspector participation in a project. Railroad Flagger/inspector participation shall be determined by local railroad officials.

The lump sum price for Railroad Control shall include all of the Contractor's costs of whatsoever nature. The price bid shall include: acquisition of additional insurance required by the railroad company to work within railroad right-of-ways, or as otherwise noted within the license agreement; acquisition of all permits, payment of all railroad flagging, inspection and associated permit fees; detouring, railroad traffic control, as required; furnishing of approved base materials, as required to bring the subgrade up to ballast elevation; supplying materials required to protect railroad tracks for equipment crossing; adhering to the conditions of permits, easements, and railroad agreements; preparation of submittals required by the railroad and receipt of approvals prior to work, design and stamping by an Engineer licensed in the State of Colorado as necessary; notification of the railroad and the public of proposed work; arrangements with the railroad for use of railroad property not covered under permits, easements, or railroad agreements; coordination with the railroad and its sub tiers for removal and replacement of the track and its related facilities; railroad safety training for all personnel working within the railroad right-of-way; and all other related and necessary materials, work and equipment required to accomplish this item in accordance with Right of Entry Permits, Pipeline Crossing Agreements and adherence to the latest edition of the AREMA Standards, the Contract Documents or as directed by the Construction Project Manager.

Measurement and Payment

At the option of the Construction Project Manager, monthly percentage payments, based upon Period of Performance, may be paid to the contractor upon satisfactory completion of and/or proper controls submitted in monthly payment application, or at the discretion of the Construction Project Manager. Up to the last progress payment or at the discretion of the Construction Project Manager.

43-1 Storm Water Management

No quantity measurement will be made for any of the work and materials required to accomplish this aspect of the construction project and payment will be based upon the completion of the work in accordance with the Contract Documents.

The lump sum price for Storm Water Management shall include all of the Contractor's costs of whatsoever nature. The price bid shall include: implementing measures per Best Management Practices (BMPs); obtaining all permits and paying any associated fees (i.e. NPDES, etc.); coordination with State and Local agencies as required to setup all required plans for the project; furnishing, installing and removing erosion control materials required by the Contractor's plans; protection of existing flow lines, inlets and manholes; care and diversion of drainage courses; pumping and bypass pumping; construction and design of special erosion control plans for emergency situations that develop during construction or unexpected weather conditions; providing filter fabric, bales, stakes, rock, filter material, silt fence, gabions, wire mesh, temporary berms, temporary diversions, temporary slope drains, check dams, geotextile protection, sediment traps and basins; clearing and grubbing for placement of planned control features, etc.; flushing, jetting and/or removal of construction debris from existing systems as required by the Construction Project Manager; stabilization of the work area by seeding and/or mulching during and after construction; disposal of work materials; maintenance of all erosion control features and seeded areas, so they function properly during construction; testing of sediment and disposal as required; and all other related and necessary materials, work and equipment required to accomplish this item in accordance with the Contract Documents.

At the option of the Construction Project Manager, one third of the lump sum price for this item may be paid to the Contractor upon satisfactory completion of and/or incorporation of proper controls, the second third may be paid upon fifty percent completion of the work as determined by the percent of work completed on the day of progress payment and the last third may be paid to the Contractor at the time of final progress payment or at the discretion of the Construction Project Manager.

44-1 Dewatering

No quantity measurement will be made for any of the work and materials required to accomplish this aspect of the construction project and payment will be based upon the completion of the work in accordance with the Contract Documents. This bid item is for dewatering to accomplish the work, however no payment will be made for dewatering due to failure to protect the excavation from storm events, failure to protect existing utilities or dewatering included elsewhere in these contract documents. No payment will be made for this lump sum item without specific written approval of the Construction Project Manager.

The lump sum price for dewatering shall include all of the Contractor's costs of whatsoever nature. The price bid shall include: pumping and bypass pumping; furnishing of all equipment and manpower; furnishing and installing erosion control materials; obtaining all required discharge permits and paying associated fees; excavation, haul, backfill; installation of caissons, pump pits, piping and drainage courses; disposal of excess and contaminated water;

Measurement and Payment

water testing; and all other related and necessary materials, work and equipment required to accomplish this item in accordance with the Contract Documents.

44-2 Water Treatment

No quantity measurement will be made for any of the work and materials required to accomplish this aspect of the construction project and payment will be based upon the completion of the work in accordance with the Contract Documents

The lump sum price for treatment of contaminated water shall include all of the Contractor's costs of whatsoever nature. The price bid shall include: pumping and bypass pumping; sampling and/or water testing; furnishing of all labor, equipment and materials for treatment of contaminated water on site; furnishing and installing of erosion control materials; obtaining all required discharge permits and paying of associated fees; installation of caissons, pumps, pump pits and drainage courses; disposal of excess and contaminated water; excavation, haul, backfill; and all other related and necessary materials and equipment required to accomplish this item in accordance with the Contract Documents. All work must proceed in a manner that does not delay the project

45-1 CIPP Laboratory Testing

The measurement for payment of this item will be the actual number of laboratory tests required for completion of this project and/or installation of related appurtenances.

The unit price bid shall include all of the Contractor's costs of whatsoever nature. The price bid shall include: coordination with a third party tester, creating the sample, for third party transport to the testing lab; receipt of written results by the Construction Project Manager; testing of: final CIPP product, sediment removed from sewer line during cleaning, water quality, soils or other types of laboratory tests as required by the Construction Project Manager; tests shall determine materials composition, concentrations of chemicals, or contaminants present, Atterberg soils limits, soil stress, permeability, volatile organic compounds; testing of CIPP pipe as outlined in the Technical Specifications; and all other related and necessary materials, work and equipment required to complete this item in accordance with the Contract Documents and as directed by the Construction Project Manager.

45-2 Quality Control Testing

No quantity measurement will be made for any of the work and materials required to accomplish this aspect of the construction and payment will be based upon completion of the work in accordance with the Contract Documents. The lump sum price bid shall include the coordination and performance of quality control testing for all facets of the Work in accordance with the City's Frequency of Testing standards.

The lump sum price for Quality Control Testing shall include all of the Contractor's costs of whatsoever nature. The price bid shall include: procurement and payment of professional services; testing of: soils, asphalt, concrete and any materials incorporated into the work (bedding, controlled low strength materials, select or imported fill, etc.) in accordance with the Contract Documents; all testing associated with any form of grouting, as specified in these contract documents; coordination and scheduling of testing; travel to and from work site; additional testing by the Contractor for its own use; re-testing of work components (backfill, concrete used in structures, etc.) as necessary to ensure conformance with Contract

Measurement and Payment

Documents, re-testing of work components due to failing QA test results by owner; delivery and transport to testing lab; furnishing of written results to the Construction Project Manager; and all other related and necessary materials, work and equipment required to complete this item in accordance with the Contract Documents and as directed by the Construction Project Manager.

At the option of the Construction Project Manager, one quarter of the lump sum price for quality control testing may be paid to the Contractor at the time of the first monthly progress payment, the second quarter may be paid at the time of the second monthly progress payment, and the third quarter may be paid to the Contractor at the time of the third monthly progress payment, or at the discretion of the Construction Project Manager. The total payment for this bid item shall not exceed seventy-five percent (75%) of the lump sum price during construction. The remaining twenty-five percent (25%) shall be paid after substantial completion of the work and only after all project testing and/or results have been completed and/or provided for project recordation. Any costs paid by the City which are the result of retesting previously failing QA events may be deducted from the Contractor's payment, as applicable and as determined by the Construction Project Manager.

-
- 46-1 Pavement Marking (Paint)**
 - 46-2 Epoxy Pavement Marking**
 - 46-3 Thermoplastic Pavement Marking**
 - 46-4 Preformed Plastic Pavement Marking**
 - 46-5 Pavement Marking Tape**

The measurement for payment of this item will be the actual square feet of pavement marking material or paint installed, as required to accomplish this aspect of the construction. Payment will be based upon completion of the work in accordance with the Contract Documents.

The unit price square foot shall include all of the Contractor's costs of whatsoever nature. The price bid shall include: pavement marking plans when required; furnishing and installation of paint, marking tape, thermoplastic and methyl methacrylate materials; furnishing of all equipment required for application of all pavement marking materials; sandblasting and high pressure cleaning to remove all dirt, laitance, and curing compound residues; and all other related and necessary materials, work and equipment for pavement marking as required in the Contract Documents or as directed by the Construction Project Manager.

47-1 Construction Surveying

No quantity measurement will be made for any of the work or materials required to accomplish this aspect of the construction project and payment will be based upon the completion of the work in accordance with the Contract Documents.

The lump sum cost shall include all of the Contractor's cost of whatsoever nature. The price bid shall include: construction surveying and staking; boundary staking; re-staking as necessary during construction; maintenance and submittal of as-built records, red-lined drawings, final survey and recordation, and prints necessary for the creation of as-built documents for all elements of the project to the Construction Project Manager ; elevation/survey checks as requested by the City during construction; verification of all survey control points, City of Denver range points, section corners and benchmarks prior to starting work; submittal of required items to the City Survey per the specifications; traffic control required to perform work under this bid item; and all other related and necessary materials, work and equipment required to accomplish this item in accordance with the Contract Documents.

Measurement and Payment

All work performed within this bid item shall be done under the supervision of a Professional Land Surveyor (PLS) or Professional Engineer (PE) who is experienced and competent in storm sewer construction, sanitary sewer construction and roadway construction surveying and is licensed in the State of Colorado.

At the option of the Construction Project Manager, one quarter of the lump sum price for Construction Surveying may be paid to the Contractor at the time of the first monthly progress payment, the second quarter may be paid to the Contractor at the time of the second monthly progress payment, and the third quarter may be paid to the Contractor at the time of the third monthly progress payment, or at the discretion of the Construction Project Manager. The total payment for this bid item shall not exceed seventy-five percent (75%) of the lump sum price during construction. The remaining twenty-five percent (25%) shall be paid after submittal of final survey and recordation documents to the Construction Project Manager for creation of as-built drawings.

47-2 Survey Monumentation

The measurement and payment of this item will be the total number of survey monuments removed and replaced for construction of the proposed sewer and/or appurtenances as indicated within the contract documents; provided, however, no measurement for payment will be made for survey monumentation required due to careless or unauthorized operations by the Contractor. No measurement will be made for locating survey monuments, preserving and referencing monuments within the project limits.

The unit price bid shall include all of the Contractor's costs of whatsoever nature. The price bid shall include: record searches and research; locating, preserving, referencing, adjusting, installing and/or restoring survey monumentation as described within the contract documents; the preparation and depositing of monument tie-out sheets and final monumentation diagram; traffic control required to perform work under this bid item; construction survey checklists, equipment calibrations; monumentation related survey records; and all other related and necessary materials, work and equipment required to accomplish this item in accordance with the Contract Documents.

All work performed within this bid item shall be done under the supervision of a Professional Land Surveyor (PLS) who is experienced and competent in storm sewer construction, sanitary sewer construction, roadway construction surveying, boundary surveying and is licensed in the State of Colorado.

50-1 Mobilization

No quantity measurement will be made for any of the work and materials required to accomplish this aspect of the construction project and payment will be based upon the completion of the work in accordance with the Contract Documents

The lump sum cost shall include all of the Contractor's costs of whatsoever nature. The price bid shall include: mobilization and demobilization to the site or sites defined within the contract documents, multiple mobilizations and demobilizations to accommodate construction moratoriums, events, schools, and/or special circumstances outlined in the Contract Documents; transporting all equipment and materials; temporary sanitary facilities; complete setup, removal, repair, coordination and payment of fees associated with temporary staging facilities; project signs; obtaining groundwater discharge permits and all additional permits required by state and local agencies to complete any facet of the work; fugitive dust control in accordance with D.R.M.C. Title II Chapter 4 Sec. 4-25 throughout entire project duration, development of fugitive particulate control plans as required and street sweeping and site cleanup as necessary; loading, hauling and disposal of all construction related debris and

Measurement and Payment

excess excavated material not provided for elsewhere in the Contract Documents; advance coordination, notification and scheduling with City and County of Denver agencies, all affected utility companies, railroads, businesses, and homeowners; scheduling of work to accommodate residents, business owners and special circumstances encountered during construction and/or as indicated in the Contract Documents; all aspects of public information services as required with the Standard Construction Specifications for the project; night and weekend work as necessary; any labor of whatsoever nature required in various areas of construction site as necessary to complete the work in accordance with the Contract Documents.

At the option of the Construction Project Manager, payment may be made in percentage installments based upon type, location and scope of work in relation to the period of performance. . The total payment for this bid item shall not exceed seventy-five percent (75%) of the lump sum price during construction. The remaining twenty-five percent (25%) shall be paid after final site cleanup, completion of all punch list items and demobilization from site.

50-1a **Emergency Mobilization**

No quantity measurement will be made for any of the work and materials required to accomplish this aspect of the construction and payment will be based upon the completion of the work in accordance with the Contract Documents. The required time for mobilization to site shall be five (5) hours from official written notification.

The measurement for payment of this item will be the actual number of emergency mobilizations required to complete the work in accordance with the Contract Documents and shall include all of the Contractor's costs of whatsoever nature. Each individual site response officially requested by the Construction Project Manager shall be considered one emergency mobilization. The price bid shall include: emergency mobilization; demobilization; transporting all equipment and materials; temporary sanitary facilities; complete setup, removal, repair, coordination and payment of fees associated with temporary staging facilities; obtaining groundwater discharge permits and all additional permits required by state and local agencies to complete any facet of the work; fugitive dust control in accordance with D.R.M.C. Title II Chapter 4 Sec. 4-25 throughout entire project duration, development of fugitive particulate control plans as required and street sweeping and site cleanup as necessary; loading, hauling and disposal of all construction related debris and excess excavated material not provided for elsewhere in the Contract Documents; advance coordination, notification and scheduling with City and County of Denver agencies, all affected utility companies, railroads, businesses, and homeowners; scheduling of work to accommodate residents, business owners and special circumstances encountered during construction and/or as indicated in the Contract Documents; all aspects of public information services as required with the Standard Construction Specifications for the project; night and weekend work as necessary; any labor of whatsoever nature required in various areas of construction site as necessary to complete the work in accordance with the Contract Documents.

END OF MEASUREMENT AND PAYMENT

PART 1 - GENERAL

1.1 RELATED DOCUMENTS: The General Contract Conditions, Drawings, and Division-1 Specification sections apply to Work of this Section.

1.2 SUMMARY:

- A. Work of this Section consists of installation of an underground irrigation system including the following:
1. Trenching, stockpiling excavation materials, refilling and compacting trenches.
 2. Complete irrigation system including but not limited to piping, valves, fittings, heads and wiring, and final adjustments to insure complete coverage.
 3. Water connections.
 4. Replacement of unsatisfactory materials.
 5. Cleanup, inspections, and approval.
 6. Tests.
- B. Related Work:
1. Concrete Flatwork: Section 02520
 2. Soil Preparation: Section 02920
 3. Turfgrass Seeding: Section 02932
 4. Native Seeding: Section 02933
 5. Sodding: Section 02935
 6. Trees and Shrubs: Section 02950
 7. Tree Retention and Protection: section 02150

1.3 REFERENCES

- A. Conform to requirements of reference information listed below except where more stringent requirements are shown or specified in Contract Documents.
1. American Society for Testing and Materials (ASTM) - Specifications and Test Methods specifically referenced in this Section.
 2. Underwriters Laboratories (UL) - UL Wires and Cables.
 3. National Sanitation Foundation (NSF) – Piping and backflow prevention.
 4. American Water Works Association – Piping and backflow prevention.

1.4 QUALITY ASSURANCE

- A. Irrigation Contractor Qualifications – Irrigation Contractor shall have had considerable experience and demonstrate ability in the installation of irrigation system(s) of specific type(s) in a neat, orderly and responsible manner in accordance with recognized standards of workmanship. To demonstrate ability and experience necessary for this Project, submit if requested by Parks Project Manager, prior to contract award the following:

1. List of 3 projects completed in the last 2 years of similar complexity to this project. Description of projects shall include:
 - a. Name of project.
 - b. Location.
 - c. Owner.
 - d. Brief description of Work and project budget.

B. Special Requirements.

1. Work involving substantial plumbing for installation of copper piping, backflow preventer(s), and related Work shall be executed by licensed and bonded plumber(s). Secure a permit at least 48 hours prior to start of installation.
2. Tolerances - Specified depths of mains and laterals and pitch of pipes are minimums. Settlement of trenches is cause for removal of finish grade treatment, refilling, compaction, and repair of finish grade treatment.
3. Coordination With Other Contractors - Protect, maintain, and coordinate work with work under other Sections.
4. Damage To Other Improvements - Contractor shall replace or repair damage to grading, soil preparation, seeding, sodding, or planting done under other Sections during Work associated with installation of irrigation system at no additional cost to the City.
5. Water Delivery Interruption – When working on an existing irrigation system, the Irrigation Contractor shall contact the Parks Project Manager and inform him 72 hours in advance of any water interruption that is required.
6. Contractor shall post signage in visible locations on site indicating “IRRIGATION TESTING AND MAINTENANCE IN PROGRESS” when Work (construction or warranty) requires irrigation system operation between the hours of 10AM to 6 PM.
7. Work involving high voltage electrical wiring, grounding and related Work shall be executed by licensed and bonded electrician(s). Secure a permit at least 48 hours prior to start of installation
8. Coordination with other contractors: Irrigation installer shall protect, maintain, and coordinate his work with other work under this contract.
9. Refer to maintenance requirements for water during construction, 1.9.B.1.

C. Pre-Construction Conferences and site meetings:

1. Contractor shall schedule and conduct a pre-construction conference to review in detail quality control and construction requirements for equipment and materials used to perform the Work. Conference shall be scheduled not less than 10 days prior to commencement of Work. All parties required to be in attendance shall be notified no later than 7 days prior to date of conference. Contractor shall notify qualified representatives of each party concerned with that portion of Work to attend conference, including but not limited to the Parks Project Manager, Contractor's Superintendent, and Installer.
2. Prior to commencement of Work, Contractor shall schedule an on-site conference with Parks Project Manager, Parks Forestry and any other parties designated by Parks Project Manager to discuss tree protection requirements, marshalling locations, traffic control, and equipment access. Provide a minimum of 7 days notice prior to date of conference.
3. Contractor shall schedule weekly on-site conferences with Parks Project Manager and any other parties designated by Parks Project Manager to review project

progress.

4. Contractor or Consultant as designated by Parks shall record Minutes of each conference and distribute to all parties in attendance within five (5) days of conference.

1.5 SUBMITTALS - Prepare and make submittals in accordance with conditions of the Contract prior to installation of any irrigation equipment:

- A. Material List: Submit a complete list of materials, indicating manufacturer, model number and description of all materials and equipment to be used. Show appropriate dimensions and adequate detail to accurately portray intent of construction.
- B. Shop Drawings: If applicable, submit shop drawings indicating electrical wiring design and assembly of backflow preventer, including plumbing and foundation/support system if the installation differs from the manufacturer's recommended installation.
- C. Samples:
 1. Valve clusters: Provide a completely built electrical valve cluster. This mock-up, to include three electric valves, quick coupler, angle valve, and manifold and riser, may be incorporated into the work toward the end of the project.
 2. Swing joints: Provide a pre-manufactured or constructed swing joint assembly as per detail.
- D. Operation and Maintenance Data: Coordinate scheduling/precipitation instructions with the City's maintenance personnel. Submit three (3) bound brochures to Parks Project Manager including:
 1. Winterization and spring start-up procedures.
 2. Cut sheets of products.
 3. Manufacturer's maintenance and checking instruction for irrigation controller.
 4. Manufacturer's maintenance and operation instruction for weather station and any other water conservation equipment.
 5. Manufacturer's maintenance and checking instruction for backflow preventer (if applicable).
 6. Manufacturer's maintenance and operation instruction for pump station (if applicable).
- E. Warranty: Submit one year written warranty, in accordance with Paragraph 1.8 below.
- F. Record Drawings (As-Built):
 1. At onset of irrigation installation, Contractor will secure Xerox copies of original irrigation design from Parks Project Manager. Contractor to revise hard copy drawings in red ink as Work progresses to show any deviations from the design. Record Drawings shall be brought up-to-date at the close of the working day every Friday by a qualified draftsman. A print of Record Drawings shall be available at Project Site for review. Updated Record Drawings shall be available for review at all times.
 2. Record Drawings shall encompass entire scope of work including any altered existing equipment and altered zones. For systems that are altered less than 50 % of entire site size, the record drawing shall encompass the scope of work, and

notate the controller zone number, type of irrigation, GPM, operating PSI for any altered or added zone.

3. Preparation of Record Drawings (As-Built): Dimension from two permanent points of reference (building corners, sidewalk, road intersections or permanent structures) the location of the following items:
 - a. Point of connection.
 - b. Routing of sprinkler pressure lines. Provide dimensions for each 100 L.F. (maximum) along each routing and for each change of direction.
 - c. Routing of non-pressure lateral lines, layout and size.
 - d. Sprinkler control valves.
 - e. Quick coupling valves.
 - f. Drain valves
 - g. Master valves
 - h. Flow sensors
 - i. Rain sensors/weather station
 - j. Wire splice boxes
 - k. Control wire routing if not with pressure mainline.
 - l. Gate valves.
 - m. Air relief valves.
 - n. Sleeves.
 - o. Flush valves.
 - p. Power service drop.
 - q. Other related equipment as directed.
4. Make dimensions accurately at the same scale used in the original drawings, or larger. Notes and dimension lettering must be legible.
5. The irrigation legend must be changed to accurately reflect the irrigation equipment installed, if such equipment is not the same as originally specified on the contract documents. This includes flow rates, effective spray diameter/radius and operating pressure of all sprinkler heads.
6. Parks Project Manager will not certify any pay request submitted by the Contractor if the As-Built Drawings are not current, and processing of pay request will not occur until As-Built Drawings are updated.
7. Final Submittal: Upon completion of Project, prior to final acceptance, secure digital copy of irrigation design from Parks Project Manager and record As-Built information that reflects all changes made over the course of the construction project, prepared by a qualified draftsman. As-Built Drawings shall include details, including any revisions as per actual installation. Deliver and submit to Parks Project Manager for review one 3 mil. Mylar prints of As-Built, and digital As-Built drawing on disk in both PDF and CAD format (include any related X-ref files, plot files and pen settings.) Make any additional changes to the file as directed by the Parks Project Manager prior to final submittal and approval.
8. Request for final payment will not be certified or processed until all As-Built prints and digital files have been received and approved.

G. Controller Zone Maps and Programming Schedule:

1. Do not prepare zone maps and programming schedules until record drawings have been reviewed and approved by the Parks Project Manager. Project Manager shall provide an example of Controller Charts required.

2. Provide one controller zone map for each automatic controller installed.
 - a. Chart shall be reproduction of record drawing, one page sized 11" by 17". If photo reduction prints are required, keep reduction to maximum size possible to retain full legibility.
 - b. Chart shall be print of actual record drawing of the system, showing the entire area covered by that controller on one sheet.
 - c. Identify controller, all remote valves and lateral lines of each remote control valve, using a distinctly different color for each zone. Include the entire area of the controller's coverage. Provide a legend.
3. Provide one zone map for the entire project.
 - a. Chart shall be reproduction of record drawing, one page maximum 36" by 48", photo reduced to maximum size and legibility.
 - b. Identify all controllers, remote valves and lateral lines using different colors to distinguish adjacent zones.

4. Provide one controller programming schedule for each automatic controller installed, one page maximum, 8-1/2" by 11". Project Manager shall provide an example of Controller Programming Schedule required.

5. Following review of charts and schedules by Parks Project Manager, provide two additional color duplicates of controller charts and controller schedules. One set of controller charts and schedules shall be laminated between two layers of 3 mil. plastic sheet. Provide digital copies of charts and schedules in pdf format.
6. Charts and controller schedules shall be completed and reviewed prior to final review of irrigation system.
7. Request for final payment will not be certified or processed until all prints and files for controller charts and schedules have been received and approved.

1.6 DELIVERY, STORAGE, AND HANDLING

A. Packing and Shipping:

1. Deliver all components to job site in original unopened packaging containers prominently displaying manufacturer's name, volume, quantity, contents, instructions, and conformance to local, state, and federal law. Remove and replace cracked, broken, or contaminated items or elements prematurely exposed to moisture, inclement weather, snow, ice, temperature extremes, fire, or jobsite damage.
2. Handling, storage and delivery of PVC pipe:
 - a. Exercise care in handling, loading and storage of PVC pipe.
 - b. Provide 48 hours advance notice of delivery to Parks Project Manager for observation of unloading and handling of PVC materials during delivery.
 - c. All PVC pipe shall be transported in a vehicle which allows length of pipe to lie flat so as not to subject it to undue bending or concentrated

external loads. All sections of pipe that have been dented or damaged shall be discarded, and if installed, shall be replaced with new piping.

B. Storage and Protection:

1. Deliver, unload, store, and handle materials, packaging and bundling products in dry, weatherproof condition in manner to prevent damage, breakage, deterioration, intrusion, ignition, and vandalism.

1.7 JOBSITE CONDITIONS:

A. Existing Conditions:

1. Soil Conditions: Investigate the type of soil and conditions in which lines are to be installed and allow for same in proposal. No extra payment will be allowed due to difficulty in trenching, unless approved by the Parks Project Manager.
2. Contractor is responsible for understanding the scope of related operations as specified and indicated in the Drawings and Specifications before beginning Work under this Section.
3. Report unsatisfactory conditions in writing to the Parks Project Manager. Commencement of installation means acceptance of existing conditions by the Contractor

B. Protection of Property:

1. Preserve and protect all trees, plants, monuments, structures, and paved areas from damage due to Work of this Section. In the event damage does occur, all damage to inanimate items shall be completely repaired or replaced to satisfaction of the Parks Project Manager, and all injury to living plants shall be repaired or replaced by the City. All costs of such repairs shall be charged to and paid by Contractor.
2. Protect buildings, walks, walls, and other property from damage. Erect and maintain barricades, warning signs and lights, and provide guards as necessary or required to protect all persons on the site. Damage caused to asphalt, concrete, or other building material surfaces shall be repaired or replaced at no cost to the City. Restore disturbed areas to original condition.

C. Protection of Existing Trees:

1. Consult with Parks' Forestry as requested by Project Manager prior to trenching or boring within tree drip-lines. All trenching or work under limb spread of any and all evergreens or low branching deciduous material shall be done by hand or by other methods so as to prevent damage to limbs or branches.
2. Where it is necessary to excavate adjacent to existing trees, use all possible care to avoid injury to trees and tree roots. Excavation in areas where 2-inch and larger roots occur shall be done by hand. Roots 2 inches or larger in diameter, except directly in the path of pipe of conduit, shall be tunneled under and shall be heavily wrapped with burlap to prevent scarring or excessive drying. Where a trenching machine is operated close to trees having roots smaller than 2 inches in diameter, wall of trench adjacent to tree shall be hand trimmed, making clean cuts through roots. Trenches adjacent to trees shall be closed within 24 hours,

and when this is not possible, side of trench adjacent to tree shall be kept shaded with moistened burlap or canvas.

3. Directional micro-boring is permitted within TPA (tree protection area) must occur below 36 inches deep in the soil and may not take place anywhere within the area from the outermost edge of the drip line to the trunk of any tree. Any exception must be agreed upon by the City Forester or a representative of the City Forester.

D. Protection and Repair of Underground Lines:

1. Request proper utility company to stake exact location (including depth) of all underground electric, gas, sewer, and telephone lines. Take whatever precautions are necessary to protect these underground lines from damage. If damage does occur, all damage shall be repaired by Utility Owner. All costs of such repairs shall be paid by Contractor unless other arrangements have been made.
2. Request City, in writing, to locate all private utilities (i.e., electrical service to outside lighting) before proceeding with excavation. If, after such request and necessary staking, private utilities which were not staked are encountered and damaged by Installer, they shall be repaired by the City at no cost to Installer. If Contractor damages staked or located private utilities, they shall be repaired by Utility Owner at Contractor's expense unless other arrangements have been made.

E. Replacement of Paving and Curbs:

1. Where trenches and lines cross existing roadways, paths, curbing, etc., damage to these shall be kept to a minimum and shall be restored to original condition.

1.8 WARRANTY/GUARANTY:

- A. Provide one year written warranty for material and installation from date of Substantial Completion.
- B. Expenses due to vandalism before Substantial Completion shall be borne by Contractor.
- C. Settling of backfilled trenches which may occur during guaranty period shall be repaired at no expense to the City, including complete restoration of damaged property.
- D. City will maintain turf and planting areas during warranty period, so as not to hamper proper operation of irrigation system, unless maintenance by Contractor is specified by contract. Contractor is responsible to monitor and coordinate controller scheduling and maintenance with Parks maintenance staff for any seeding, sodding or planting areas under Contractor's warranty.
- E. The City and County of Denver Department of Parks and Recreation reserves the right to make temporary repairs during the warranty period as necessary to keep systems in operating condition without voiding the Contractor's warranty, nor relieving Contractor of his responsibilities.
- F. Contractor shall make repairs and replacement promptly when notified, within three days of notification. If Contractor fails to make repairs within three days, City may make such repairs at Contractor's expense.

1.9 MAINTENANCE:

- A. Where applicable, furnish the following maintenance items to City prior to Final

Acceptance:

1. Two sprinkler heads for each size and type specified. Two nozzles for each type of head.
2. Two wrenches for each type of head cover. Two wrenches for removing and installing each type of head.
3. Two valve keys for operating each type of manual valve.
4. Two keys for valve markers.
5. Two keys for valve box covers.
6. Two valve keys and hose swivels for each type of quick coupling valve, four controller cabinet keys, and one remote control device for each project.

1.10 Maintenance During Project Construction:

- A. Contractor shall fence, water and keep weed free any turf and planting areas within active phases of construction. Coordinate controller scheduling and maintenance operations with Parks maintenance staff and Parks Project Manager for portions of Park property unaffected by current phases of construction. Turf and plants affected by mainline Work or irrigation water service shutdown during irrigation season shall receive watering per Parks' schedule, with no interruption of watering greater than 72 hours.
- B. Additional Maintenance During Warranty Period:
 - a. Make repairs and replacements needed due to defective workmanship and materials.
 - b. Winterization – include cost in bid for winterizing complete system at conclusion of irrigation season (during which system received final acceptance) within 3 days notification by the City. System shall be voided of water using compressed air or similar method accepted by Parks Project Manager. Reopen, operate and adjust system malfunctions accordingly during April of following season within 3 days of notification by City.

PART 2 - PRODUCTS

2.1 GENERAL:

- A. Equipment must have performance characteristics to operate per the design conditions indicated. If any discrepancy or conflict exists between the quantities of equipment listed in the schedule and quantities shown on the Drawings, the Drawings shall govern.
- B. All material shall be of the highest grade possible and where applicable, shall be marked accordingly. All material shall be new.

2.2 PIPE AND PIPE FITTINGS:

- A. Main and Lateral Lines:
 1. Main Lines (pressurized, downstream of backflow prevention units):
 - a. Class 200 PVC BE (size 1-1/2" through 2-1/2")
 - b. Class 200 PVC RT (size 3" and larger).
 - c. Velocities in PVC mainline shall not exceed 5 FPS.
 - d. All PVC pipe will conform to the requirements of the United States Department of Commerce commercial standard Type 1-ASTM-D-2241.
 - e. HDPE pipe, pressure rating DR 9 (200 PSI) may be used by approval of Project Manager for portions of mainline that require boring such as below trees and paving. HDPE requires fusion butt weld transition to

PVC mainline using ISCO Industries IPS Bell MJ Adapter with kit, model #ISMFMJ03IPSBELL.

2. Lateral Lines: 100 PSI High Density NSF Polyethylene Piping - 1" minimum diameter.
 - a. Velocity of water flow in polyethylene pipe shall not exceed 7-1/2 feet per second.
3. Main line water flow velocity shall not exceed five (5) feet per second.

B. Sleeving:

1. Horizontal sleeves under paved surfaces: Class 200 PVC.
2. Vertical sleeves for access to drains and valves: Class 200 PVC.
3. Horizontal sleeving for boring applications: HDPE

C. Brass Pipe and Fittings:

1. Brass Pipe - 85% red brass, ANSI Schedule 40 screwed pipe.
2. Fittings - Medium brass, screwed 125 pound class.

D. Plastic Pipe and Fittings:

1. Identification Markings: Identify all pipe with following indelible markings:
 - a. Manufacturer's name.
 - b. Nominal pipe size.
 - c. Schedule of class.
 - d. Pressure rating.
 - e. NSF (National Sanitation Foundation) seal of approval.
 - f. Date of extrusion.
2. Gasketed End Pipe (Pressurized main line 3" and larger) – Manufactured from virgin Polyvinyl Chloride compound in accordance with ASTM D2241 and ASTM D1784; cell classification 1254-B, Type 1, Grade 1.
 - a. All fittings and service tees (3" and larger) – Harco or Leemco ductile iron, grade 70-55-05 in accordance with ASTM A-536. Fittings shall have deep bell push-on joints with factory installed gaskets meeting ASTM F-477.
 - b. Lubricant – As recommended by manufacturer of pipe fittings.
 - c. Pipe Restraints on all fittings and service tees and pipe to pipe restraints: Harco or Leemco, installation as recommended by manufacturer. Joint Restraint shall be used on all Valves and Ductile Iron Fittings where there is a change of direction (such as a bend or tee) or flow area (such as a reducer, cap/plug). Each fitting bell shall be restrained to the pipe inserted in it per manufacturer's recommendations. See Manufacturer catalog for appropriate selection or chart supplied on plans.
3. SDR21-200 PVC pipe (Pressurized main line 2-1/2" and under).
 - a. Pipe will be assembled with Schedule 80 PVC fittings using ASTM-F-656 purple primer followed with heavy bodied ASTM-D-2564 glue.
 - b. Fittings shall be installed with thrust blocks as per Detail.

4. Flexible Plastic Pipe (non-pressure lateral lines):
 - a. Manufactured from virgin polyethylene in accordance with ASTM D2239, designated as PE 3408. Maximum size 2"; minimum size 1".
 - b. Fittings - Manufactured in accordance with ASTM D2609; PVC Type 1 cell classification 12454-B.
 - c. Clamps - All stainless steel worm gear screw clamps. Use 2 clamps per joint on all insert fittings.
 - d. Risers for Pop-up Heads - Shall be swing pipe, 0.49 ID, operating pressure of 80 PSI, manufactured by Rainbird or equal.

2.3 VALVES:

A. Gate Valve or Isolation Valve:

1. Valve for 3" and larger mainline: Shall be cast iron body, push-on, left-hand opening, square nut operated, rubber resilient seated, mechanical joint AWWA gate valve with clear waterway equal to full diameter of pipe. Able to withstand continuous working pressure of 150 PSI. Wheel type handle is unacceptable.
2. Valve for 2-1/2" and smaller mainline (solvent-weld): Shall be Matco-Norca 10RS resilient wedge gate valve with threaded ends and non-rising stem.

B. Automatic Control Valve:

1. Automatic Valve for Potable Water System: Rain Bird PEB-PRS-D Series Valve having manual flow adjustment and manual bleed nut.
2. Automatic Valve for Non-Potable Water System: Rain Bird PESB-PRS-D Series Valve.
3. Manifold: Manifold to be constructed out of Schedule 80 PVC pipe, fittings, and nipples, with ductile iron riser nipple and angle valve Champion brass body 200RS angle valve with brass unions as per details and plans.

C. Manual Drain Valve:

1. Drain Valve: Mueller Oriseal #H-10283 or MacDonald AY 1" 3061 with brass swing joint assembly.

D. Quick Coupling Valves:

1. Buckner "Wing Thing" Q44LCAR10 brass two-piece body with winged stabilizer, designed for working pressure of 150 PSI; 1" FIP. Equip quick coupler with locking rubber cover, key and brass swivel. Size as shown on Drawing
2. All Quick Coupling Valves to be used for winterization shall be constructed of all brass swing joint and fittings.

E. Master Valve:

1. Mainline 2" and larger Master Valve shall be Bermad 410 normally open valve.
2. Mainline smaller than 2" Master Valve shall be Superior 3100 normally open valve.

F. Flow Sensor Assembly:

1. Mainline 1-1/2" – 4" and with flow greater than .5 feet per second, flow sensor shall be Data Industrial 228-PV, sized according to mainline size.
2. Mainline larger than 4", flow sensor shall be Data Industrial 220-B mounted with Harco tapping saddle sized according to mainline size.
3. Mainline 1" with flow less than .5 feet per second, flow sensor shall be Data Industrial 4000

G. Valve Boxes:

1. All valve boxes will have a stainless steel hex bolt locking system.
2. Isolation Valves, Quick Coupling Valves, Drain Valves, Wire Splices and Ground Rods - Carson Brooks 10" round box,
 - a. brand lids: Isolation/Gate Valve with "GV", Quick Coupler Valve with "QC", Manual Drain Valve with "DV", Air Relief Valve with "AR", Master Valve with "MV", Flow Sensor with "FS" and Wire Splice Box with "SB".
3. Electric Control Valve Box: Shall have locking cover branded with the zone number.
 - a. Single or double valve location only, 3/4 inch through 2 inch: Carson Brooks #1220 jumbo box with 910-4 bolt down T-cover.
 - b. Multiple valve clusters, 3/4 inch through 2 inch, max. three (3) control valves per box: Carson Brooks #1730-18 box with 910-4 bolt down T-cover or Rain Bird VB Max.
4. Box Color for valves shall be green for potable systems, purple for non-potable systems.
5. Gravel Leveling Bed and Drainage Sump in Valve Boxes: 3/4" crushed gravel lined in geo-textile, as indicated on Drawings.

H. Backflow Preventer:

1. High hazard, reduced pressure type, approved by USC or other approved testing laboratory; fully ported, ball-type gate valves on units 2" or smaller, resilient gate valves on units larger than 2"; as manufactured by Febco or approved equal.
2. Backflow Preventer Cover: Guardshack enclosure of appropriate size, equipped with Lock Shield Brackets, manufactured by BPDI, phone: 800-266-5411. Color: forest green.
3. For devices 2" and smaller, install Sentry SC75-200 locking device.
4. Concrete Pad: Comply with Section 02520.

I. Air Relief Valve:

1. On systems 3" or larger, as per plan: Bermad 4415 (all cast iron) 2" double purpose vacuum air release valve.

J. Pressure Reducing Valve:

1. Watts commercial grade or equal required where system pressures exceed 100PSI.

2.4 SPRINKLER HEADS:

- A. Heads: Provide fabricated riser units of the type and size as indicated on the Drawings. Heads of a specific type or function in the system shall be of the same manufacturer and shall be marked with the manufacturer's name and identification in such a position that they can be identified without being removed from the system.
 - 1. Pop-Up Sprinkler Heads in turf areas: Rain Bird 1804 SAM-PRS or 1806 SAM-PRS.
 - 2. Pop-Up Sprinkler Heads in native grass areas and flower bed areas: Rain Bird 1812 SAM-PRS.
 - 3. Pop-Up Sprinkler Nozzles shall be Rain Bird U-Series nozzle. Strip series, rotary, MPR and VAN nozzles may be used for specific approved applications.
 - 4. Gear Driven Heads: Hunter I-20, I-25, I-40 or Rain Bird 3500, 5000 Plus, 5500, or 8005 series with stainless steel risers, SAM, PRS and MPR options as available.
- B. Flexible Connectors to Lateral Pipe:
 - 1. Pop-up Heads: Shall be Rain Bird Swing Pipe, 1/2" SPX Series, connected to lateral pipe with Rain Bird SBE-050 spiral barbed ell PVC insert fittings.
 - 2. Gear Driven Heads: Shall be field constructed swing joints as per detail, connected to lateral pipe with PVC insert fittings.

2.5 LOW VOLUME IRRIGATION

- A. Valve – Rain Bird X CZ 100 B Com for reuse water and X CZ 150 Com for potable water. Valves shall be installed in Carson Brooks #1220 jumbo box or approved equal with 910-4 bolt down T-cover. Brand lid with zone number.
 - 1. All low volume irrigation shall be zoned independently from turf, and product applications may not be mixed within zone.
- B. Lateral pipe – Flexible polyethylene pipe as per specifications 2.2.D.4. See Drawings for installation depth.
- C. Sub-surface irrigation – Netafim Techline CV, 0.26 or .4 GPH emitter with 12" or 18" spacing. See Drawings for installation and depth of pipe.
 - 1. Requires Netafim 120 mesh filter in Carson 1419-12 valve box with corner hex bolt down cover. Brand lid with "FIL".
 - 2. Flush valve in Carson round 10" valve box with bolt down T-cover as per Drawings. Brand lid with "FV".
- D. Tree/Shrub Bubblers – Rain Bird 1400 series Tree and Shrub Bubbler or Rain Bird SQ nozzle installed as per Drawings.
 - 1. Discharge rate must not exceed soil infiltration rate.
 - 2. Top of bubbler or nozzle shall not exceed 2" height above mulch/soil surface.

2.6 AUTOMATIC CONTROL SYSTEM:

A. Automatic Controller:

1. Central Control systems shall be Toro Sentinel special build central control with wireless output boards. Update to Sentinel central control is required on all projects unless a variance is granted by Denver Parks Water Conservation.
 - a. Sentinel satellite controller in prefabricated enclosure with pedestal is available exclusively through C.P.S. Distributors. Contractor shall purchase fully assembled enclosure including back panel, terminal strips, power supply unit, interior fused disconnect with 120 volt duplex outlet, heavy duty transient surge protection boards, antenna(s) with cable, louvers and fan kit. Enclosure and pedestal shall be stainless steel with factory applied powder coating finish, color #6005 Tiger Drylack color chart. Enclosure shall have a heavy duty hasp for locking. Model number is per plan as specified by Toro.
 - b. Provide one hand-held remote control unit for each project specified or as specified per plan.
 - c. 450 MHz radio communication shall be fully compatible with Denver Parks and Recreation frequency required by the Operations District.
2. If variance is granted, Controller must have the following minimum characteristics:
 - a. Solid state, 14-day clocks, with multiple programming capabilities.
 - b. Capable of opening normally closed electric solenoid type valve.
 - c. Automatic Timing: Capable of incremental units from 3 to at least 60 minutes per station.
 - d. Water Budgeting: Capable of global program run time changes in percentage increments.
 - e. Ability to provide repeat and/or syringe cycle capabilities and ability to eliminate or isolate one station without disturbing remaining controller features.
 - f. Flow sensing capability with automatic shut-down or alarm signal.
 - g. Minimum 40 VA transformer rating.
 - h. Controller cabinets shall be stainless steel Strongbox or Hoffman enclosure with factory-applied Federal Green powder-coat finish and heavy duty locking hasp. Size cabinet per specification from manufacturer.
 - i. Controller and cabinet require grounding per manufacturer recommendations, outside disconnect, inside fused disconnect, interior duplex GFI outlet.
3. Controller and remote control equipment: Manufacturer and Model shall be noted on Drawing.
4. Contractor shall provide concrete pad, 120V electrical power, conduits, grounding and control wire connections to terminal surge strips .
5. Concrete Pad: Comply with plan detail and Section 02520.

B. Electrical Control Wiring:

1. Low Voltage:
 - a. Electrical Control Wire for 24VAC solenoid – Golf Course Sprinkler

- Wire - #14 to #10 AWG UL approved direct burial solid conductor copper wiring with polyethylene insulation .045" thickness.
- b. Electrical Common Wire – Golf Course Sprinkler Wire - #12 AWG UL approved direct burial solid conductor copper wiring with polyethylene insulation .045" thickness.
 - c. Data Wires – Paige 7171D-A direct burial shielded and armored signal cable with polyethylene jacket.
 - d. Wire Colors: Consistent color system throughout.
 - 1) Control Wires – Black.
 - 2) Common Wires – White.
 - 3) Spare Control Wires – Red.
 - 4) Spare Common Wires – Purple.
 - 5) Data Wires – Green and Blue
 - 6) Tracer Wire – Yellow
 - e. Control Wire connections and splices shall be made with 3M DBM direct bury splice, or similar UL listed dry splice methods.
2. Splice Box: Carson Brooks 10" round box, branded "SB."
 3. Mainline Tracer Wire – Install one continuous AWG UL No. 10 tracer wire as detailed above all mainline. Loop wire into control box. Color shall be yellow.
 4. High Voltage – Type required by local codes and ordinances, of proper size to accommodate needs of equipment serviced.

2.7 MISCELLANEOUS MATERIALS:

- A. Rain Sensor: Hunter wireless Rain Klik with by-pass or Mini-Klik (wired) with Sensor Guard or approved equal. Rain sensor shall be installed per manufacturer's recommendations.
- B. Concrete Thrust Blocks as per plan for all 2-1/2" and smaller PVC solvent weld mainline: Minimum of one cubic foot of cast-in-place concrete in compliance with Section 03300 and 3.3.C below.

PART 3 – EXECUTION

3.1 PREPARATION:

- A. Utility Locates: Contact Utility Notification Center of Colorado at or 8-1-1 or 1-800-922-1987 prior to any excavation, for the marking of underground member utilities. The indication of utilities on the Drawings does not relieve the Contractor of the responsibility for utility location. Route trenches to avoid existing utilities. Verify with the Parks Project Manager any required relocation prior to installation.
- B. Landscape Plan Review and Coordination: Contractor will be held responsible for coordination between landscape and irrigation system installation. Landscape material locations shown on the Landscape Plan shall take precedence over the irrigation system equipment locations. If irrigation equipment is installed in conflict with the landscape material locations shown on the landscape plan, the Contractor will be required to relocate the irrigation equipment, as necessary, at Contractor's expense.

- C. Pressure Verification: Contractor shall field verify the tap size, static pressure and verify Gallons Per Minute flow at the project site, prior to commencing Work or ordering irrigation materials, and submit findings in writing to Parks Project Manager. If Contractor fails to verify tap size, static water pressure and flow prior to commencing Work or ordering irrigation materials, Contractor shall assume responsibility for all costs required to make system operational and the costs required to replace any damaged landscape material. Damage shall include all required material costs, design costs, labor costs and plant replacement costs.
- D. Inspection: Examine areas and conditions under which Work of this Section is to be performed. Do not proceed with Work until unsatisfactory conditions have been corrected.
 - 1. Grading operations, with the exception of fine grading, shall be completed and approved by Parks Project Manager before staking or installation of any irrigation system begins.
- E. Layout: Lay out and stake system before beginning installation. Staking shall occur as follows:
 - 1. Mark, with paint, routing of pressure supply line and flag heads for all new zones. Contact Parks Project Manager 48 hours in advance and request review of staking. Parks Project Manager will advise installer as to the amount of staking to be prepared. Parks Project Manager will review staking and direct changes if required. Review does not relieve installer from coverage problems due to improper placement of heads after staking.
 - 2. Valve boxes and mainline will not be located in ball fields, and multi-use sport fields, recovery zones, or below playground equipment.
 - 3. If project has significant topography, freeform planting beds, or other amenities which could require alteration of irrigation equipment layout as deemed necessary by Parks Project Manager, do not install irrigation equipment in these areas until Parks Project Director has reviewed equipment staking.
 - 4. Parks Project Manager may request Parks Forestry approval of proposed trenching prior to start of trenching.
 - 5. Review backflow prevention device location and operation with Parks Project Manager prior to mainline installation.

3.2 EXCAVATION AND BACKFILL:

- A. Install mainline pipe and wire sleeving under existing asphalt paving, concrete walks and critical root zones by directional boring. Pot-hole existing utilities for location and depth in advance of boring operations. When pot-holing in cross streets: include all permits, traffic control, backfill, compaction and surface restoration as required by the City and County of Denver Transportation Engineering Standards and Specifications. Compact backfill around end of sleeves to 95% compaction in landscape areas.
- B. Excavation:
 - 1. Trenching:
 - a. Trench excavation shall follow, as much as possible, layout shown on Drawing. Dig trenches straight and support pipe continuously on bottom

of trench. Trench bottom shall be clean and smooth with all rock and organic debris removed. Comply with OSHA standards for all trenching and excavation.

- b. Trenching under limb spread of existing trees: Accomplish by hand or other method that will not damage limbs or branches. Keep trenches at least 6 feet from trunk of existing trees. Refer to Section 02150: Tree Retention and Protection for additional precautions.

2. Clearances:

3. Main pressure line: Make trenches of sufficient width to properly assemble and position pipe in trench. Clearances:

- a. Piping 3" and Larger: Minimum clearance of piping 3" or larger shall be 5 inches horizontally on both sides of the trench.
- b. Piping 2-1/2" and Smaller: Trenches shall have a minimum width of 4 inches.
- c. Line Clearance: Provide min. 6 inches of clearance between each line, and min. 12 inches of clearance between lines of other trades.
- d. Lateral pipe: Trenches shall have a minimum width of 4 inches.
- e. Line Clearance: Provide not less than 6 inches of clearance between each line, and not less than 12" of clearance between lines of other trades.

4. Pipe and Wire Depth to finish grade:

- a. Pressure Supply Piping within Parks – 30 inches from top of pipe (maximum variation 2").
- b. Pressure Supply Piping within Right-of-Way – 24 inches from top of pipe (maximum variation 2").
- c. PVC Sleeving – at specified pipe or wire depth.
- d. Non-pressure Piping (gear driven heads) – 18 inches from top of pipe (maximum variation 2").
- e. Non-pressure Piping (pop-up heads) – 18 inches from top of pipe (maximum variation 2").
- f. Control Wiring – Side of pressure main when installed in the same trench; 24 inches from top of wire bundle where installed separately from mainline trench.

5. Boring will be permitted only where pipe must pass under obstruction(s) which cannot be removed. In backfilling bore, final density of backfill shall match that of surrounding soil. It is acceptable to use sleeves of suitable diameter installed first by jacking or boring, and pipe laid through sleeves. Observe same precautions as though pipe were installed in open trench.

6. Vibratory Plow: Not permitted without written authorization of Parks Project Manager.

3.3 INSTALLATION OF IRRIGATION EQUIPMENT: Locate all equipment as near as possible to locations designated. Deviations shall be reviewed and approved by Parks Project Manager prior to installation.

A. Sleeving:

1. Install sleeving under asphalt paving and concrete walks prior to concreting and

- paving operations to accommodate piping and wiring.
- 2. Minimum depth to top of pipe shall be determined by depth of mainline and lateral lines.
- 3. Lay sleeve to drain at minimum grade of 3" per 100'.
- 4. Sleeving located under areas where asphalt or concrete paving will be installed shall be bedded with sand (a layer 6" below pipe and 6" above pipe).
- 5. Compact backfill material in 6" lifts at 95% maximum density determined in accordance with ASTM D1557, using manual or mechanical tamping devices.
- 6. Sleeving under existing walks or concrete pavement shall be done by jacking, boring or hydraulic driving, but where cutting of asphalt and/or concrete is necessary, it shall be done and replaced at no cost to the City. Obtain permission to cut walks from Parks Project Manager.
- 7. Do not allow sleeves to become filled with soil or other undesirable material. Tape ends of sleeves until commencement of pipe installation.
- 8. Mark sleeves as per plans in a manner to ensure easy location in the future.

B. Installation of Piping:

- 1. **PVC Mainlines:**
 - a. Snake pipe in trench as much as possible to allow for expansion and contraction. Place manual drain valves at low points and dead ends of pressure supply piping to insure complete drainage of system. When pipe laying is not in progress, or at end of each day, close pipe ends with tight plug or cap. Perform Work in accordance with good practices prevailing in piping trades.
 - b. Slope pipe at minimum 3" per 100' to manual drain valve and drainage sump. Field adjust as needed.
 - c. Solvent Weld PVC Pipe (all pipes 2-1/2" and smaller): Lay pipe and make all plastic to plastic joints in accordance with manufacturer's recommendations. Do not install pipe when air temperature is below 40 degrees (F).
 - d. Gasketed End Pipes: Lay pipe and make pipe-to-fitting or pipe-to-pipe joint, following OR70 recommendations (Johns-Manville Guide for Installation of Ring-Tite Pipe), or pipe manufacturer's recommendations. Install Harco or Leemco fittings and pipe restraints on all fittings and adjacent pipe runs per manufacturer's recommendations.

C. Thrust Blocks on 2-1/2" and smaller PVC mainline: Construct thrust blocks as per plans.

- 1. Contact Parks Project Manager prior to placing thrust blocks, for observation of thrust block excavation and initial placement. Size thrust blocks per plan:

2. Soil Type	lbs./SF
a. Mulch, Peat, etc.	0
b. Soft Clay	500
c. Sand	1,000
d. Sand and Gravel	1,500
e. Sand and Gravel with Clay	2,000
f. Sand and Gravel Cemented with Clay	4,000
g. Hard Pan	5,000

D. Flexible Plastic (Polyethylene) Pipe –

1. Lay pipe and assemble fittings according to manufacturer's recommendations.
- E. Control Wiring - Low Voltage Wiring:
1. Bury control wiring between controller and electric valves in pressure supply line trenches, strung as close as possible to main pipe lines with such wires to be consistently located below and to one side of pipe, or in separate trenches.
 2. Install tracer wire as per plan detail.
 3. Bury control wiring between controller and electric valves in pressure supply line trenches, strung as close as possible to main pipe lines with such wires to be consistently located below and to one side of pipe, or in separate trenches.
 - a. Bundle all 24 volt wires at 10 foot intervals and lay with pressure supply line pipe to one side of the trench.
 4. Provide an expansion loop at every pressure pipe angle fitting, every electric control valve location (in valve box), and every 500 feet. Form expansion loop by wrapping 24" of wire around a 3/4 inch pipe and withdrawing pipe.
 5. Make all splices and E.C.V. connections using 3M DBY & DBR connectors or similar UL listed dry splice method.
 6. Install all control wire splices not occurring at control valve in a separate Carson Industries Model #910-10 body with 910-4 bolt down T-cover wire splice valve box with branded with WS in 1" high letters minimum.
 7. Install one control wire for each control valve.
 8. Run five (5) spare #14 AWG UFUL control wires and one (1) spare common wire from controller pedestal to the end of each and every leg of mainline. Label spare wires at controller and wire stub box.
- F. High Voltage Wiring for Automatic Controller:
1. Provide 120 volt power connection to automatic controller.
 2. All electric work shall conform to local codes, ordinances, and authorities having jurisdiction. All high voltage electrical work shall be performed by licensed electrician.
- G. Installation of Valves:
1. Electric Control Valves: Install electric control valves as detailed on the Drawings.
 2. Quick Coupling Valves: Install quick coupling valves as detailed on the Drawings.
 3. Drain Valves: Install manual drain valves as detailed on the Drawings.
 4. Install manual drain valves at all low points in pressure supply line, whether indicated on the drawing or necessitated by actual conditions, to ensure proper drainage of the mainline.
 5. Isolation/Gate Valves: Install as detailed in locations shown on Drawings.
 6. Valve Boxes: Install one valve box for each type of valve installed as detailed. Install gravel compaction and leveling bed after compaction of subgrade and prior to setting of valve box.
 - a. Install valve boxes flush with finish grade and square to adjacent surface features.
 - b. When valve boxes are grouped together, allow at least 24 inches between

- valve box sides.
 - c. Cutting of valve box to give clearance for piping or valves will not be allowed.
- 7. Backflow Prevention Device: Contractor must meet all applicable laws, rules and codes, including but not limited to Uniform Building codes, Plumbing Codes and State Water Regulations. Assemblies must be installed per the manufacturer's specifications. Backflow devices shall not be installed within the public right-of-way.
 - a. Install in strict accordance with current requirements of Denver Water. Connections to the Denver Water System are to have an approved assembly for the type protection they provide, either isolation or containment.
 - b. Successful Testing of backflow assembly by a certified Backflow Prevention Assembly Tester is Contractor's responsibility. Test reports shall be forwarded to Denver Water in accordance with the State of Colorado regulations. Copies of the report, the tester's certification and the certification of the testing equipment used are to be forwarded to Parks Project Manager.
 - c. Request for final payment will not be certified or processed until certification reports have been filed with Denver Water and received by Parks Project Manager.

H. Installation of Sprinkler Heads:

1. Install sprinkler heads where designated after Parks Project Manager has approved Staking. Set to finish grade as detailed.
2. Spacing of heads shall not exceed the maximum indicated on Drawing unless re-staked as directed by Parks Project Manager. In no case shall the spacing exceed maximum recommended by manufacturer.
3. Install gear driven heads on swing-joint risers as detailed. Angled nipple relative to non-pressure line shall be no more than 45 degrees or less than 10 degrees.
4. Install pop-up heads on swing pipe as detailed.
5. Adjust part circle heads for proper coverage. Adjust heads to correct height after sod is installed. Plant placement shall not interfere with intended sprinkler head coverage, piping, or other equipment. Parks Project Manager may request nozzle changes or adjustments without additional cost to the City.

I. Backfilling:

1. Do not begin backfilling operations unless authorized by Parks Project Manager and all required systems tests have been completed. Backfilling shall not be done in freezing weather unless authorized by Parks Project Manager. Leave trenches slightly mounded to allow for settlement after backfilling is completed. Trenches shall be finish graded prior to walk-through of system by Parks Project Manager.
2. Materials - Excavated material is generally considered satisfactory for backfill purposes. Backfill material shall be free of rubbish, vegetable matter, frozen materials, and stones larger than 1 inch in maximum dimension. Do not mix subsoil with topsoil. Material not suitable for backfill shall be hauled away. Contractor shall be responsible for providing suitable backfill if excavated material is unacceptable or not sufficient to meet backfill, compaction, and final

grade requirements.

3. Do not leave trenches open for a period of more than 48 hours. Open excavations shall be protected in accordance with OSHA regulations.
4. Compact backfill to 90% S.P.D., determined in accordance with ASTM D698 utilizing the following methods in landscape areas:
 - a. Mainline Pipe: Backfill and mechanically compact in three uniform lifts to a 95% compaction.
 - b. Secondary Pipe: Backfill in two uniform lifts and hydraulically or mechanically compact each.
 - c. Puddling or ponding and/or jetting is prohibited within 20 feet of building or foundation walls.

J. Sleeving:

1. Sleeving shall be installed at mainline or lateral pipe depth.
2. Provide for a minimum cover of 24 inches between the top of the sleeve and the bottom of the aggregate base for all pressure and non-pressure piping installed under asphaltic concrete or concrete paving.
3. Sleeving located under areas where asphalt or concrete paving will be installed shall be bedded with sand (a layer 6" below pipe and 6" above pipe).
4. Compact backfill material in 6" lifts at 95% S.P.D. determined in accordance with ASTM D698 using manual or mechanical tamping devices under pavement.
5. Sleeving under existing walks or concrete pavement shall be done by directional boring. Where cutting or breaking of walks and/or concrete is necessary, it shall be done and replaced at no cost to the City. Obtain permission to cut or break walks and/or concrete from Parks Project Manager.
6. Set in place, cap and pressure test all piping under paving, in presence of Parks Project Manager prior to backfilling and paving operations.
7. Sleeve Size Requirements for wire and pipe (control wire shall be placed in sleeving separate from pipe sleeving):
 - a. $\frac{3}{4}$ "-1 - 1/4" Pipe: 2" PVC (1)
 - b. 1-1/2" - 2" Pipe: 4" PVC (1)
 - c. 2-1/2" - 3" Pipe: 6" PVC (1)
 - d. 4" Pipe: 8" PVC (1)
 - e. 1-25 Control Wires: 2" PVC (1)
 - f. 26-50 Control Wires: 3" PVC (1)

K. Automatic Control System:

1. Sentinel Central Control:
 - a. Contractor is to arrange and pay for C.P.S. Distributors to conduct a signal test and survey to maximize signal quality of any antenna and each Sentinel controller installed, and maximize layout for flow sensing. Contact Brandon Gully, C.P.S. Site Survey is to be conducted or verified prior to construction during summer full tree leaf-out. Design is based on field test. Contractor is responsible to coordinate optimization of central control with Toro and C.P.S.
2. Install controller and controller enclosure in accordance with the Drawings and

with the manufacturer's instructions. Concrete pad, 120v electrical power, conduits, grounding and control wire connections to terminal surge strips shall be by contractor.

3. Provide controller to earth ground as per manufacturer recommendation. Central Control Satellite: Provide controller to earth ground in accordance with Article 250 of the National Electrical Code (NEC). Earth ground shall be 10 OHMS or less as measured by a Megger® or similar instrument, or as per manufacturer recommendation. Contractor shall arrange and perform testing in presence of Denver Parks and Recreation representative or consultant.
 - a. Ground rods are to have a minimum diameter of 5/8" and a minimum length of 8 feet. Copper wire shall be connected to the ground rod by the installer using a Cadweld GR1161G "One-Shot Plus" welding kit.
 4. Install above ground wiring in rigid conduit in accordance with applicable codes.
- L. Coordinate installation with electrical work to insure electrical power supply line(s) are provided to controller location(s).
- M. Wire control valves in a logical zone sequence.
1. Permanently engrave date of installation and Xcel service pole number inside controller enclosure.
- N. Miscellaneous Items:
1. Rain Sensor: Install in accordance with manufacturer's instructions, located as per Drawing.

3.4 FIELD QUALITY CONTROL:

- A. Flushing: After piping, risers, and valves are in place and connected, but prior to installation of sprinkler heads, quick coupler assemblies, and hose valves, thoroughly flush piping system under full head of water pressure from dead end fittings. Maintain flushing for 5 minutes through furthest valves. Cap risers after flushing.
- B. Testing pressurized mainline: Conduct tests in presence of Parks Project Manager. Arrange for presence of Parks Project Manager 48 hours in advance of testing. Supply force pump and all other test equipment.
1. Set in place, cap and pressure test all piping under paving, in presence of Parks Project Manager prior to backfilling and paving operations.
 2. After backfilling and installation of all control valves, fill pressure supply line with water, and pressurize to 40 PSI over the designated static pressure or 120 PSI, whichever is greater, for a period of 2 hours.
 3. Leakage, Pressure Loss: Test is acceptable if less than 2 pounds of pressure is

evident during the test period.

4. Leaks: Detect and repair leaks. Replace defective PVC pipe with new full length pipe section. No pipe splices will be accepted within pipe sleeve. No PVC pressure couplings or slip-fix repair couplings will be allowed.
5. Retest system until test pressure can be maintained for duration of test.
6. Before final acceptance, pressure supply line shall remain under pressure for a period of 48 hours with no evidence of leaks or failures.

C. Testing Controller Operations:

1. Functional test of the control system shall be performed and demonstrate that all parts of the control system function as specified or intended, as per Parks **Central Control Certification Checklist**. The functional test for each system shall consist of not less than 30 days of continuous, satisfactory operation of the complete system serviced by a controller.
2. Any materials determined to be faulty as part of the installation shall be replaced or corrected by the Contractor at his expense in a manner respective to the Plans, Details and other sections of this Specification. In the event of a system failure due to faulty installation, programming or workmanship, the 30 day period will be repeated until testing is complete.

D. System Operations Orientation:

1. System Operation Training Session: A training and orientation session for Parks staff shall be required.
 - a. The Contractor, the irrigation subcontractor, a representative of the manufacturer or distributor, and representatives of Parks maintenance and Water Conservation shall be present. The date and time of the session and attendees present shall be subject to approval by a Parks representative.
 - b. The completed Record Drawings, Controller Zone Maps and Controller Program Schedule shall be reviewed for approval by Parks Water Conservation Unit.
 - c. Controller features, flow sensing, alarms and programming will be reviewed.
 - d. Hand held operation of field units will be demonstrated.

E. Walk-Through for Substantial Completion:

1. Arrange for Parks Project Manager's presence 48 hours in advance of walk-through.
2. Entire system shall be completely installed and operational and trenches shall be finish graded prior to scheduling of walk-through.
3. Electrically operate each zone in its entirety for Parks Project Manager at time of walk-through. Project inspection by Parks Project Manager shall include:
 - a. Review operation, coverage, head/nozzle adjustment, and system adjustment per specifications.
 - b. Open all valve boxes to confirm materials, gravel bedding, compaction, elevation, workspace access within boxes, clearance from lid and bedding, locking mechanisms, and zone branding. Interior of boxes should be free of visible soil. All valves must be tagged with zone identification and valve

box lids must be branded with zone valve identification. Verify connections in all zone valve and wire splice boxes.

- c. Contractor shall resistance test all spare common and hot wires for continuity in the presence of Parks Project Manager.
- d. Confirm irrigation heads are at specified elevation and distance from paved surfaces and curbs, plumb and soil compacted.
- e. Inspect concrete size and elevation of pads for backflow assemblies, master valves, and enclosure pads. Confirm quality of concrete, finish, access, spare conduit/sleeving as required for wiring.
- f. Confirm quality of controller enclosure and mounting (there must be no gap between controller and concrete), grounding, high voltage installation, low voltage wiring, ID tagging of wires in controller, and communication set up. Each controller must have a color-coded zone chart and programming chart as per specifications.
- g. Contractor shall submit written certification for testing that proper grounding for all controllers has been installed to Owner.
- h. Review trench and related excavation repair including backfill, compaction, fine grade, seed and sod installation.
- i. Review appropriate use of purple valve lids and other product as required for reuse water applications.

4. Certify Central Control Operation: Central control operation will be verified by Parks Certification of Central Control Checklist.
 - a. Generate a punch list of items to be corrected prior to Final Completion.
 - b. Furnish all materials and perform all work required to correct all inadequacies of coverage due to deviations from Contract Documents.

F. Walk-Through for Final Completion:

1. Arrange for Parks Project Manager's presence 48 hours in advance of walk-through.
5. Show evidence to Parks Project Manager that the City has received all accessories, charts, record drawings, and equipment and backflow certification reports and controller grounding assembly certificates as required before Final Completion walk-through is scheduled.
6. Operate each zone, in its entirety for Parks Project Manager at time of walk-through to insure correction of all incomplete items.
7. Items deemed not acceptable by Parks Project Manager shall be reworked to complete satisfaction of Parks Project Manager.
8. If after request to Parks Project Manager for walk-through for Final Completion of irrigation system, Parks Project Manager finds items during walk-through which have not been properly adjusted, reworked, or replaced as indicated on punch list from previous walk-through, Contractor shall be charged for all subsequent walk-throughs. Funds will be withheld from final payment and/or retainage to Contractor, in amount equal to additional time and expenses required by Parks Project Manager to conduct and document further walk-through meetings as deemed necessary to ensure compliance with Contract Documents.

3.5 ADJUSTING:

- A. Upon completion of installation, "fine-tune" entire system by regulating valves, adjusting

patterns and break-up arms, and setting pressure reducing valves at proper and similar pressure to provide optimum and efficient coverage. Flush and adjust all sprinkler heads for optimum performance and to prevent overspray onto walks, roadways, and buildings as much as possible. Heads of same type shall be operating at same pressure +/- 7%.

- B. If it is determined that irrigation adjustments will provide proper coverage and improved water distribution as determined by the Parks Project Manager, Contractor shall make such adjustments prior to Final Acceptance as directed, at no additional cost to the City. Adjustments may also include changes in nozzle sizes, degrees of arc, and control valve throttling.
 - C. All sprinkler heads shall be set perpendicular to finish grade unless otherwise designated.
 - D. Areas that do not conform to designated operation requirements, due to unauthorized changes or poor installation practices, shall be immediately corrected at no additional cost to the City.
- 3.6 CLEANING - Maintain continuous cleaning operation throughout duration of Work. Dispose of, off-site at no additional cost to the City, all trash, excess soil or debris generated by installation of irrigation system.

END OF SECTION 02810

Final Geotechnical Investigation Report

Final
Geotechnical Investigation Report
Hampden Heights Phase II, Drainage Improvements
Denver, Colorado

Yeh Project No. 213-091

October 17, 2014

Prepared for:

Enginuity
Attn: Jeffrey Sickles, P.E.
10106 West San Juan Way, Suite 215
Littleton, Colorado 80127

Prepared by:

Yeh and Associates, Inc.
2000 Clay Street, Suite 200
Denver, Colorado 80211

Phone: 303-781-9590
Fax: 303-781-9583

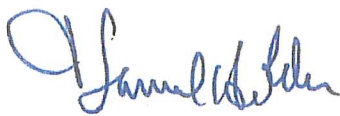

T. Samuel Holder, P.E.
Senior Project Manager

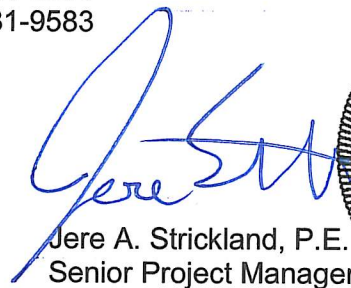

Jere A. Strickland, P.E.
Senior Project Manager

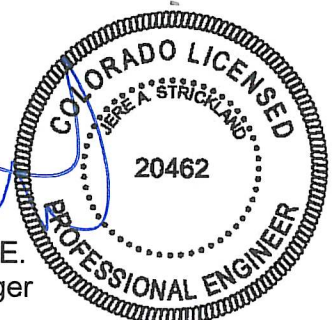

Table of Contents

1. PURPOSE AND SCOPE OF STUDY	2
2. PROPOSED CONSTRUCTION	2
3. GEOLOGICAL SETTING AND SITE CONDITIONS	3
4. SUBSURFACE INVESTIGATION	3
4.1 FIELD EXPLORATION	3
4.2 LABORATORY TESTING	4
5. SUBSURFACE CONDITIONS	5
5.1 INFILTRATION TESTS	5
5.1 FOUNDATION CONCRETE	5
6. DESIGN RECOMMENDATIONS FOR STRUCTURES AND RETAINING WALLS	6
6.1 RETAINING WALLS	6
6.2 RIP RAP	7
6.3 WATER QUALITY VAULT	7
7. CONSTRUCTION RECOMMENDATIONS	7
7.1 SITE GRADING CONSIDERATIONS	7
7.2 EXCAVATION AND TRENCH CONSTRUCTION	8
8. LIMITATIONS	9
9. REFERENCES	9

List of Figures

FIGURE 1 BORING LOCATION PLAN	10
-------------------------------------	----

List of Tables

TABLE 1 INFILTRATION RATES.....	5
---------------------------------	---

List of Appendices

APPENDIX A BORING LOGS

APPENDIX B LABORATORY TEST RESULTS



1. PURPOSE AND SCOPE OF STUDY

This report presents the results of our geotechnical engineering investigation for the proposed improvements to Hampden Heights, Phase II in Denver, Colorado.

The study was performed in accordance with our proposal to Enginuity dated May 7, 2013 and your notice to proceed authorized by your subcontract.

The purpose of our study includes:

- Evaluating the general geotechnical characteristics of the subsurface soils for the proposed project focusing on the structures and;
- Providing preliminary geotechnical recommendations and parameters for the design and construction of the proposed structures.

A field exploration program consisting of geologic reconnaissance and exploratory drilling was conducted to obtain information on subsurface conditions. Yeh and Associates, Inc., through the use of private drilling subcontractor, drilled and logged exploratory borings. Soil samples were obtained during the field explorations and examined by the project personnel. The site investigation was conducted in two phases as a result of changes in the project. Representative samples were tested to determine the classification and engineering characteristics of the on-site materials. Based on the information obtained, Yeh and Associates completed an evaluation of subsurface conditions.

The recommendations contained in this report are based upon our understanding of the proposed project, the results of field and laboratory testing, engineering analyses and our experience with similar soil conditions and structures. Discussion of geotechnical engineering considerations is included in this report.

2. PROPOSED CONSTRUCTION

Based on information provided by Enginuity dated September 6, 2013; the project includes the construction of a proposed bio-retention pond and storm water culvert. The storm water will enter the retention pond from a proposed storm-water culvert from the south and when it reaches planned depth it will spill over a spillway into Cherry Creek. The proposed retention pond will be designed to retain storm water less than a 100 year storm event. Lesser amounts will pond and infiltrate into the underlying sandy soils. The pond is planned for a 2.5 foot high boulder wall generally along the south and west edge of the pond. The proposed spillway will



be constructed using 36 inch grouted boulders. Along Cherry Creek the southerly channel will be lined with planted soil rip rap. A water quality vault is proposed to be placed between the storm water culvert and the retention pond.

3. GEOLOGICAL SETTING AND SITE CONDITIONS

Geologically, the project area is mapped by Tremble and Machette as Post Piney Creek and Piney Creek alluvium (upper Holocene) consisting of gravel, sand silt and clay of modern stream flood plains. The soils encountered in the borings are consistent with this description.

Currently at the site is a temporary rip rap lined retention pond. The area is bounded by a parking lot, on the east by South Havana Street, on the west by undeveloped land and on the north by Cherry Creek. There is an existing ditch along the westerly boundary. Drainage appears to be toward Cherry Creek.

4. SUBSURFACE INVESTIGATION

4.1 Field Exploration

The scope of the services performed for this project included site reconnaissance by a representative of Yeh and Associates, subsurface explorations, laboratory testing and engineering analysis. Our initial site investigation was summarized in a letter dated November 12, 2013 and the results of that investigation have been incorporated into this report.

The August 29, 2013 boring was advanced by Dakota Drilling using their Dietrich D-50 truck mounted drill rig equipped with 4-inch diameter solid stem auger. The January 14, 2014 borings were advanced by Dakota Drilling using their track mounted CME drill rig equipped with 4-inch diameter solid stem auger. The subsurface conditions encountered in the borings were logged by a representative of Yeh and Associates.

Bore holes were drilled to pre-determined depths where a modified California or split spoon sampler was used to record blow counts and obtain samples.

To perform the modified California penetration resistance tests, a 2.0-inch inside diameter sampler was seated at the bottom of the test hole, then driven up to 12 inches with blows of a standard hammer weighing 140 pounds and falling a distance of 30 inches using a manual 140-pound hammer falling 30 inches. The driving procedure is similar to ASTM D1586, "Standard Test Method for Standard Penetration Test (SPT) and Split Barrel Sampling of Soils". The

number of blows (Blow Count) required to drive the sampler 12 inches or a fraction thereof, constitutes the N-value. The N-value, when properly evaluated, is an index of the consistency or relative density of the material tested. Split spoon samples are obtained in the same manner, but with a 1.5-inch inside diameter sampler. Boring logs are presented in Appendix A.

Groundwater measurements were made in each boring at the time of site exploration and then the borings were backfilled for safety considerations. The groundwater measurements are noted on the boring logs. The boring logs are included in the Appendix A.

The borings were located in the field by pacing from existing features. Elevation of the borings may be estimated by interpolating between the contours on the site plan provided. The accuracy of boring locations and elevations should only be assumed to the level implied by the methods used.

4.2 Laboratory Testing

Samples retrieved during the field exploration were tested by Yeh and Associates and were classified in accordance with the AASHTO and Unified Soil Classification Systems. An applicable program of laboratory testing was developed to determine engineering properties of the subsurface materials. Following the completion of the laboratory testing, the field descriptions were confirmed or modified as necessary and the summary boring log was prepared.

The material descriptions, in-situ testing, and laboratory test results were used for the geotechnical engineering analyses and the development of foundation and earthwork recommendations. Laboratory tests were performed in general accordance with the applicable local or other accepted standards.

Selected soil samples were tested for the following engineering properties:

- Dry density
- Water content
- Grain size
- Plasticity Index
- Water soluble sulfate content
- Resistivity
- pH

The laboratory test results are presented in Appendix B.

5. SUBSURFACE CONDITIONS

Boring B-1 encountered gravelly sand to 5 feet, followed by 3 feet of clay. Underlying the clay, silty sand was encountered to 21 feet, the maximum depth of exploration. Boring B-2 encountered silty sand to 21.5 feet, the maximum depth of exploration. Field penetration data indicates that the clay soils were stiff in consistency and the sand soils vary from medium dense to dense in relative density. Silty sand was encountered in all four of the infiltration borings to 5 feet, the maximum depth of exploration. The boring logs are presented in Appendix A.

Groundwater was encountered in the test boring B-1 at a depth of 14 and 6 feet in boring B-2 at the time of field exploration. These observations represent only current groundwater conditions, and may not be indicative of other times, or at other locations. Groundwater levels should be expected to fluctuate with varying seasonal and weather conditions.

5.1 Infiltration Tests

Infiltration tests were conducted in the four shallow borings, PERC-1 through PERC-4. The tests were conducted by installing 4 inch screened PVC pipe into the borings, filling the screened pipes with water and measuring the infiltration rate into the soil. The following results were obtained:

Table 1 Infiltration Rates

Boring Number	Infiltration Rate
PERC-1	4 inches per minute
PERC-2	3 inches per minute
PERC-3	3 inches per minute
PERC-4	4 inches per minute

5.1 Foundation Concrete

The concentrations of water-soluble sulfates measured in the laboratory on the shallow samples varied from 0.005 to 0.006 percent. These concentrations of water-soluble sulfates represent a Class 0 degree of sulfate attack on concrete exposed to these materials. The degree of attack



is based on a range of Class 0 (negligible) to Class 3 (very severe) as presented in the American Concrete Institute (ACI) Manual. We recommend using a Class 0 degree of sulfate attack for concrete. The requirements for sulfate resistance are provided in Section 601.04, CDOT Standard Specifications for Road and Bridge Construction.

6. DESIGN RECOMMENDATIONS FOR STRUCTURES AND RETAINING WALLS

6.1 Retaining Walls

A 250 foot long, 2.5 foot high small retaining wall (boulder wall) is proposed along the south and west side of the bio-retention pond. The proposed wall is planned to be constructed using 3 foot diameter boulders. Small retaining walls, 3 feet high or less, are usually considered to be “landscape walls” and typically are not extended to below frost line, 3 feet in Denver. However, long term performance of the wall maybe affected by freeze thaw. Some minor deflection of the wall should be anticipated.

The allowable bearing capacity for the retaining wall in medium dense silty sand is 2,500 pounds per square foot (psf). For lateral load and sliding resistance, the retaining wall should be designed for an active equivalent fluid pressure of 45 psf/ft and using a coefficient of sliding of 0.45. The lateral load and sliding resistance are ultimate values and appropriate factors of safety should be used in design.

To reduce hydrostatic loading on retaining walls, a subsurface drain system should be placed behind the wall. The drain system should consist of free-draining granular soils containing less than 5 percent fines (by weight) passing a No. 200 sieve placed adjacent to the wall. The free-draining granular material should be graded to prevent the intrusion of fines or encapsulated in a suitable filter fabric. A drainage system consisting of either weep holes or perforated drain lines (placed near the base of the wall) should be used to intercept and discharge water which would tend to saturate the backfill. Where used, drain lines should be embedded in a uniformly graded filter material and provided with adequate clean-outs for periodic maintenance. A relatively impervious soil should be used in the upper layer of backfill to reduce the potential for water infiltration. As an alternative, a prefabricated drainage structure such as geocomposite may be used as a substitute for the granular backfill adjacent to the wall.

Recommended compaction criteria for retaining wall backfill is 95 percent of the maximum dry density (AASHTO T99) within 3 percent of the optimum moisture content.

6.2 Rip Rap

The site soils are erodible silty sand. Rip rap is proposed along Cherry Creek for erosion purposes. A permanent erosion control geotextile placed between the rip rap and the in-situ soils is recommended to prevent soil loss. The geotextile should meet the requirements of CDOT Standard Specifications for Road and Bridge Section 420, Erosion Control.

6.3 Water Quality Vault

The water quality vault will have lateral earth pressure forces on the vertical faces. The differences between the lateral forces on either side of the vault will generally be relatively small and they would be considered to be balanced with respect to lateral sliding.

The allowable bearing pressure for the vault is 2,500 psf. The vault by their construction will prevent lateral movement of the tops of the side walls, thereby preventing the development of full active earth pressures. Therefore, we recommend using at-rest earth pressures for design of the side walls of the culvert. For the on-site soils we recommend an at-rest equivalent fluid pressure of 55 psf/ft. These earth pressures do not include a factor of safety and are not applicable for submerged soil and hydrostatic conditions.

7. CONSTRUCTION RECOMMENDATIONS

7.1 Site Grading Considerations

Site grading should conform to CDOT Standard Specifications for Road and Bridge Construction. We recommend permanent cut and fill slopes be constructed at a maximum slope angle of 2.5 horizontal to 1 vertical unless the fill slopes are constructed with engineered reinforcement.

Engineered fill should be placed and compacted in horizontal loose lifts of 8 inches or less in thickness, using equipment and procedures that will produce a uniform fill with the recommended moisture contents and densities throughout the lift. Backfill shall uniformly distributed in layers brought up equally on all both sides of the water quality vault.

Recommended compaction criteria for engineered fill is 95 percent of the maximum dry density (AASHTO T99) within 3 percent of the optimum moisture content.

Cut slopes should be protected from surface water runoff to prevent erosion and slope failure. Good surface drainage should be provided around all permanent cuts and fills to direct surface

runoff away from the slope faces. Fill slopes, cut slopes, and other stripped areas should be protected against erosion by re-vegetation or other methods

Prior to fill placement the areas should be stripped to remove existing vegetation and other deleterious materials from construction areas. All exposed surfaces should be free of mounds and depressions, which could prevent uniform compaction.

Stripped materials consisting of vegetation, organic materials or fill with debris should be wasted from the site or used to revegetate landscaped areas or exposed slopes after completion of grading operations.

Fill against the walls should be compacted to densities specified and accomplished with hand-operated tampers or other lightweight compactors. Over compaction may cause excessive lateral earth pressures, which could result in wall movement.

Clean on-site soils or approved imported materials may be used as fill material. Imported fill material should be reviewed by the geotechnical engineer prior to importing to the site.

The recommendations for placement and compaction criteria presented herein, assume that fill depths will be about 10 feet. Fills of about 10 feet or less, when placed and compacted as recommended in this report, will experience some settlement (generally about 1 inch or less).

7.2 Excavation and Trench Construction

Excavations into the on-site soils will encounter a variety of conditions. All excavations must comply with the applicable local, State, and Federal safety regulations, and particularly with the excavation standards of the Occupational Safety and Health Administration (OSHA).

Construction site safety, including excavation safety, is the sole responsibility of the Contractor as part of its overall responsibility for the means, methods, and sequencing of construction operations. Yeh and Associates recommendations for excavation support are provided for the Client's sole use in planning the project, in no way do they relieve the Contractor of its responsibility to construct, support, and maintain safe slopes. Under no circumstances should the following recommendations be interpreted to mean that Yeh and Associates is assuming responsibility for either construction site safety or the Contractor's activities.

We believe the overburden sands encountered on this site will classify as Type C materials OSHA requires that unsupported cuts be no steeper than 1½:1 for Type C excavations up to 20 feet in height. In general, we believe that these slope ratios will be temporarily stable under



unsaturated conditions. Flattened slopes may be required if excavations encounter groundwater or the slopes will be exposed for an extended period of time. Please note that an OSHA-qualified “competent person” must make the actual determination of soil type and allowable sloping in the field.

The soils encountered by the proposed excavations may vary significantly across the site. The preliminary classifications presented above are based solely on the materials encountered in widely spaced exploratory borings. The contractor should verify that similar conditions exist throughout the proposed area of excavation.

As a safety measure, it is recommended that all vehicles and soil piles be kept to a lateral distance equal to at least the depth of the excavation from the crest of the slope. The exposed slope face should be protected against the elements and monitored by the contractor on at least a daily basis.

8. LIMITATIONS

The analyses and recommendations presented in this report are based upon our data obtained from the borings at the indicated locations, field observations, laboratory testing, our understanding of the proposed construction and other information discussed in this report. It is possible that subsurface conditions may vary between or beyond the points explored. The nature and extent of such variations may not become evident until construction. If variations appear, we should be contacted immediately so we can review our report in light of the variations and provide supplemental recommendations as necessary. We should also review the report if the scope of the proposed construction, including the proposed loads, finished elevations or structure locations, change from those described in this report. The conclusions and recommendations contained in this report shall not be considered valid unless Yeh and Associates reviews the changes and either verifies or modifies the conclusions of this report in writing.

9. REFERENCES

Colorado Department of Transportation, Standard Specifications for Road and Bridge Construction, 2011



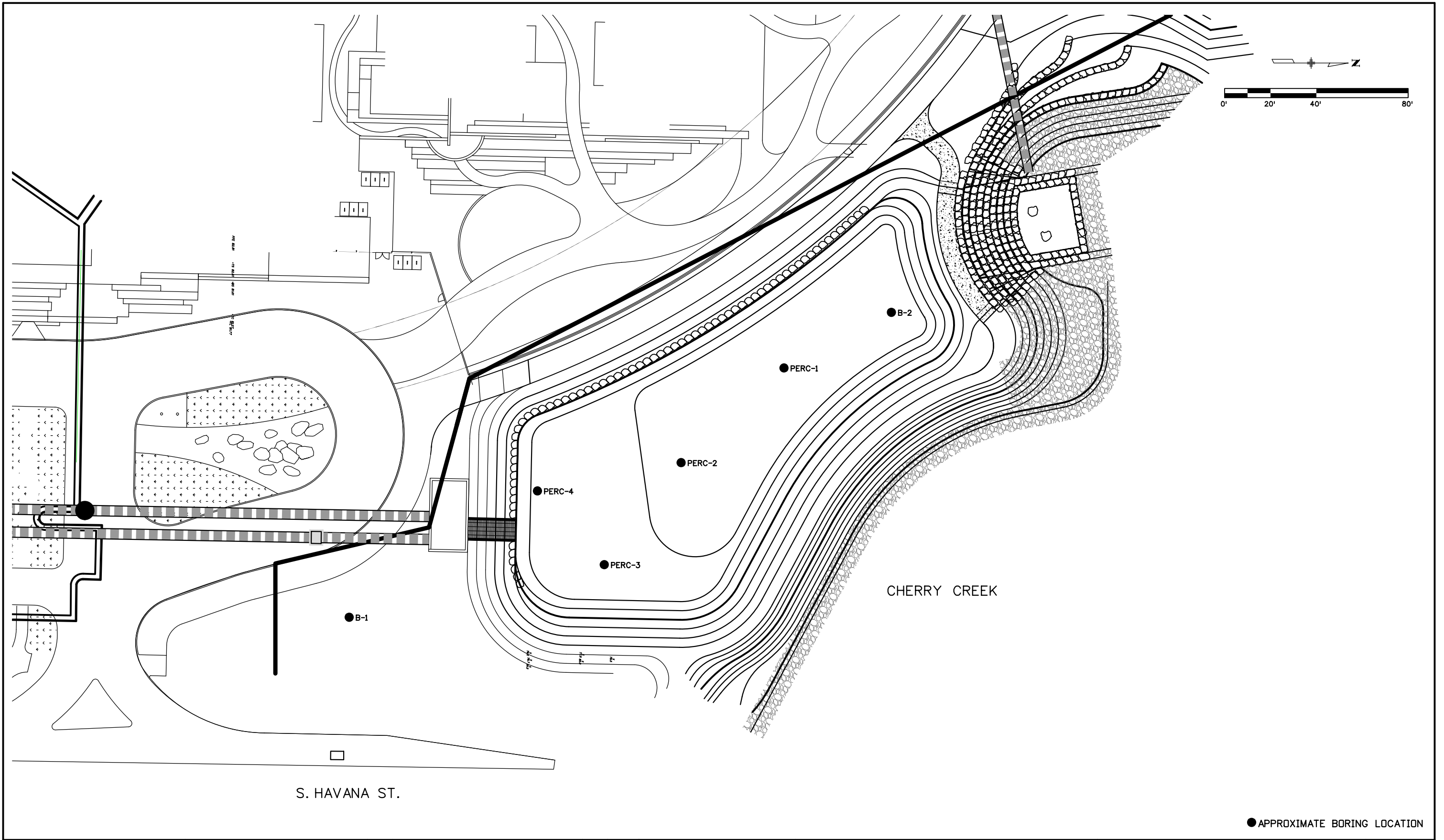

● APPROXIMATE BORING LOCATION



NO.	SHEET REVISION	BY	DATE

REUSE OF DOCUMENT
 This document is the property of Yeh & Associates, Inc. The ideas incorporated on this document are instruments of professional service and shall not be used for any other project without written authorization from Yeh & Associates, Inc.

DRAWN BY: M. WALZ	DATE: 2-11-14
CHECKED BY: S. HOLDER	DATE: 2-11-14
DESIGNED FOR: ENGINUITY INC.	
PROJECT NUMBER: 213-091	
SCALE	
HORIZ:	VERT:

PROJECT:
HAMPDEN HEIGHTS STORM SEWER
BORING LOCATION PLAN

FIGURE
 1

Appendix A

BORING LOGS





Boring Began: 8/29/2013
 Drilling Method: Solid-Stem Auger
 Drill: D-50 Dietrich
 Driller: Dakota
 Logged By: S.Maloney
 Final By: S. Holder
 Inclination: Vertical

Completed: 8/29/2013
 Drill Bit:
 Casing:
 Weather: Clear

Total Depth: 21.0 ft
 Ground Elevation:
 Location: 50 feet west of Havana
 Coordinates: N: E:

Ground Water Notes:

Depth	▽ 14.0 ft	-	-	-
Date	8/29/13	-	-	-
Time	-	-	-	-

Elevation (feet)	Depth (feet)	Run / Sample Type	Recovery (%)	Rock	Soil Samples		Lithology	Material Description	Field Notes and Lab Tests
				RQD	Blows per 6 in	N			
								0.0 - 5.0 ft. gravelly SAND with some silt, brown, moist, medium dense.	
	5				6/6	12		5.0 - 8.0 ft. CLAY with some sand, black, moist, stiff.	MC= 21.5 % DD= 97.9 pcf S= 0.006 %
	10				15/15	30		8.0 - 21.0 ft. silty SAND , light brown, moist to wet, medium dense.	MC= 2.9 % DD= 116.2 pcf #200= 4 % LL= NV PL= NP PI= NP AASHTO: A-1-b (0) USCS: SW
	15				7/12	19			MC= 8.4 % DD= 124.2 pcf
	20				17/23	40			MC= 1.2 %
								Bottom of Hole at 21.0 ft.	



Boring Began: 1/28/2014 Completed: 1/28/2014 Total Depth: 21.5 ft
 Drilling Method: Solid-Stem Auger Drill Bit: Ground Elevation:
 Drill: Track Mounted CME 50, Manual Hammer Casing: None Location:
 Weather: Cool, Calm, Clear Coordinates: N: E:
 Driller: Dakota Drilling

Logged By: R. Beach
 Final By: R. Beach
 Inclination: Vertical

Ground Water Notes: Observed at approximately 6 feet at time of drilling

Depth	▽ 6.0 ft	-	-	-
Date	1/14/14	-	-	-
Time	-	-	-	-

Elevation (feet)	Depth (feet)	Run / Sample Type	Recovery (%)	Rock	Soil Samples		Lithology	Material Description	Field Notes and Lab Tests
				RQD	Blows per 6 in	N			
	5	X			8/7/8	15		0.0 - 21.5 ft. silty SAND with occasional gravels, light brown to dark brown, moist to wet, medium dense to dense.	MC= 15.4 % #200= 7 % LL= NV PL= NP PI= NP S= 0.005 % AASHTO: A-1-b (0) USCS: SW-SP
	10	X			11/12/12	23			
	15	X			15/23/25	38			
	20	X			14/22/24	36			
								Bottom of Hole at 21.5 ft.	



Boring Began: 1/28/2014 Completed: 1/28/2014 Total Depth: 5.0 ft
 Drilling Method: Solid-Stem Auger Drill Bit: Ground Elevation:
 Drill: Track Mounted CME 50, Manual Hammer Casing: None Location:
 Weather: Cool, Calm, Clear Coordinates: N: E:

Driller: Dakota Drilling
 Logged By: R. Beach

Ground Water Notes: Not observed at time of drilling

Final By: R. Beach
 Inclination: Vertical

Depth	-	-	-	-
Date	-	-	-	-
Time	-	-	-	-

Elevation (feet)	Depth (feet)	Run / Sample Type	Recovery (%)	Rock		Soil Samples		Lithology	Material Description	Field Notes and Lab Tests
				RQD		Blows per 6 in	N			
	5								0.0 - 5.0 ft. silty SAND with occasional gravel, brown, moist.	
									Bottom of Hole at 5.0 ft.	Perc. Rate at 4 inches/min



Boring Began: 1/28/2014 Completed: 1/28/2014 Total Depth: 5.0 ft
 Drilling Method: Solid-Stem Auger Drill Bit: Ground Elevation:
 Drill: Track Mounted CME 50, Manual Hammer Casing: None Location:
 Weather: Cool, Calm, Clear Coordinates: N: E:

Driller: Dakota Drilling
 Logged By: R. Beach

Ground Water Notes: Not observed at time of drilling

Final By: R. Beach
 Inclination: Vertical

Depth	-	-	-	-
Date	-	-	-	-
Time	-	-	-	-

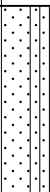
Elevation (feet)	Depth (feet)	Run / Sample Type	Recovery (%)	Rock	Soil Samples		Lithology	Material Description	Field Notes and Lab Tests
				RQD	Blows per 6 in	N			
	5							0.0 - 5.0 ft. silty SAND with occasional gravel, brown, moist.	
								Bottom of Hole at 5.0 ft.	Perc. Rate at 3 inches/min



Boring Began: 1/28/2014

Completed: 1/28/2014

Total Depth: 5.0 ft

Drilling Method: Solid-Stem Auger

Drill Bit:

Ground Elevation:

Drill: Track Mounted CME 50, Manual Hammer

Casing: None

Location:

Weather: Cool, Calm, Clear

Coordinates: N: E:

Driller: Dakota Drilling

Logged By: R. Beach

Ground Water Notes: Not observed at time of drilling

Final By: R. Beach

Inclination: Vertical

Depth
Date
Time

-
-
-

-
-
-

-
-
-

-
-
-

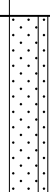
Elevation (feet)	Depth (feet)	Run / Sample Type	Recovery (%)	Rock	Soil Samples		Lithology	Material Description	Field Notes and Lab Tests
				RQD	Blows per 6 in	N			
	5							0.0 - 5.0 ft. silty SAND with occasional gravel, brown, moist.	
								Bottom of Hole at 5.0 ft.	



Boring Began: 1/28/2014

Completed: 1/28/2014

Total Depth: 5.0 ft

Drilling Method: Solid-Stem Auger

Drill Bit:

Ground Elevation:

Drill: Track Mounted CME 50, Manual Hammer

Casing: None

Location:

Weather: Cool, Calm, Clear

Coordinates: N: E:

Driller: Dakota Drilling

Logged By: R. Beach

Ground Water Notes: Not observed at time of drilling

Final By: R. Beach

Inclination: Vertical

Depth
Date
Time

-
-
-

-
-
-

-
-
-

-
-
-

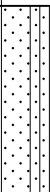
Elevation (feet)	Depth (feet)	Run / Sample Type	Recovery (%)	Rock	Soil Samples		Lithology	Material Description	Field Notes and Lab Tests
				RQD	Blows per 6 in	N			
	5							0.0 - 5.0 ft. silty SAND with occasional gravel, brown, moist.	
								Bottom of Hole at 5.0 ft.	

LABORATORY TEST RESULTS



Sieve Analysis		Hydrometer Analysis
Sieve Opening in Inches	U.S. Standard Sieves	Size of Particles in mm

Sieve Size	% Passing
3"	-
2 1/2"	-
2"	-
1 1/2"	-
1"	-
3/4"	-
1/2"	100
3/8"	99
#4	96
#10	74
#40	19
#200	4

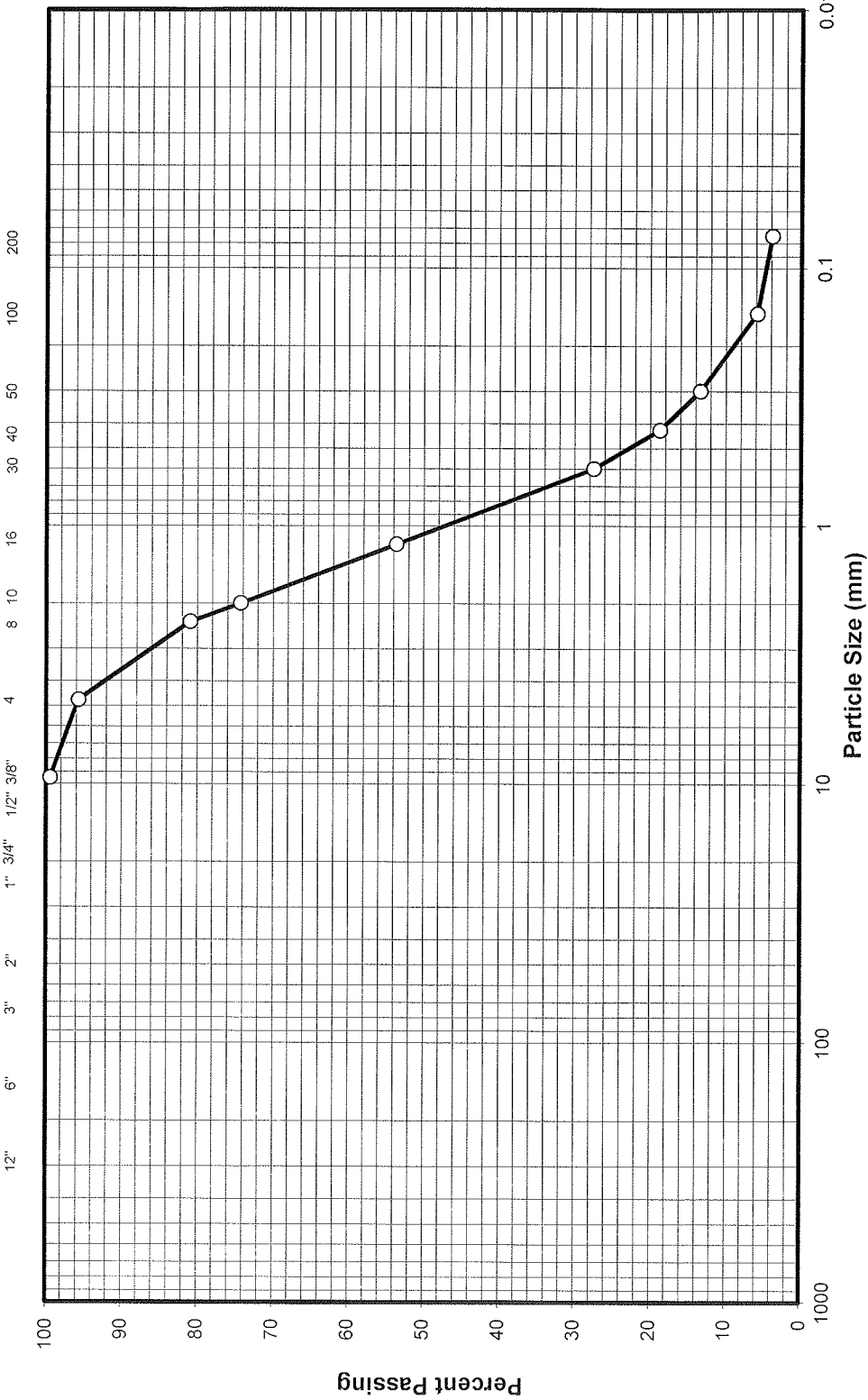

Gravel (%)	4	LL	NV	Project Name:	Hampden Heights Phase 2
Sand (%)	92	PL	NP	Sample ID:	B-1
Fines (%)	4	PI	NP	Sample Depth (ft.):	10
Sample Description:	A-1-b (0) / SW				



Yeh & Associates, Inc.
Geotechnical Engineering Consultants

SIEVE ANALYSIS

Drawn By:	MA	Project No.:	213-091
Checked By:	Jere	Figure No.:	-
Date:	02/06/14		

Sieve Analysis		Hydrometer Analysis
Sieve Opening in Inches	U.S. Standard Sieves	Size of Particles in mm

Sieve Size	% Passing
3"	-
2 1/2"	-
2"	-
1 1/2"	-
1"	-
3/4"	100
1/2"	99
3/8"	98
#4	92
#10	69
#40	15
#200	3

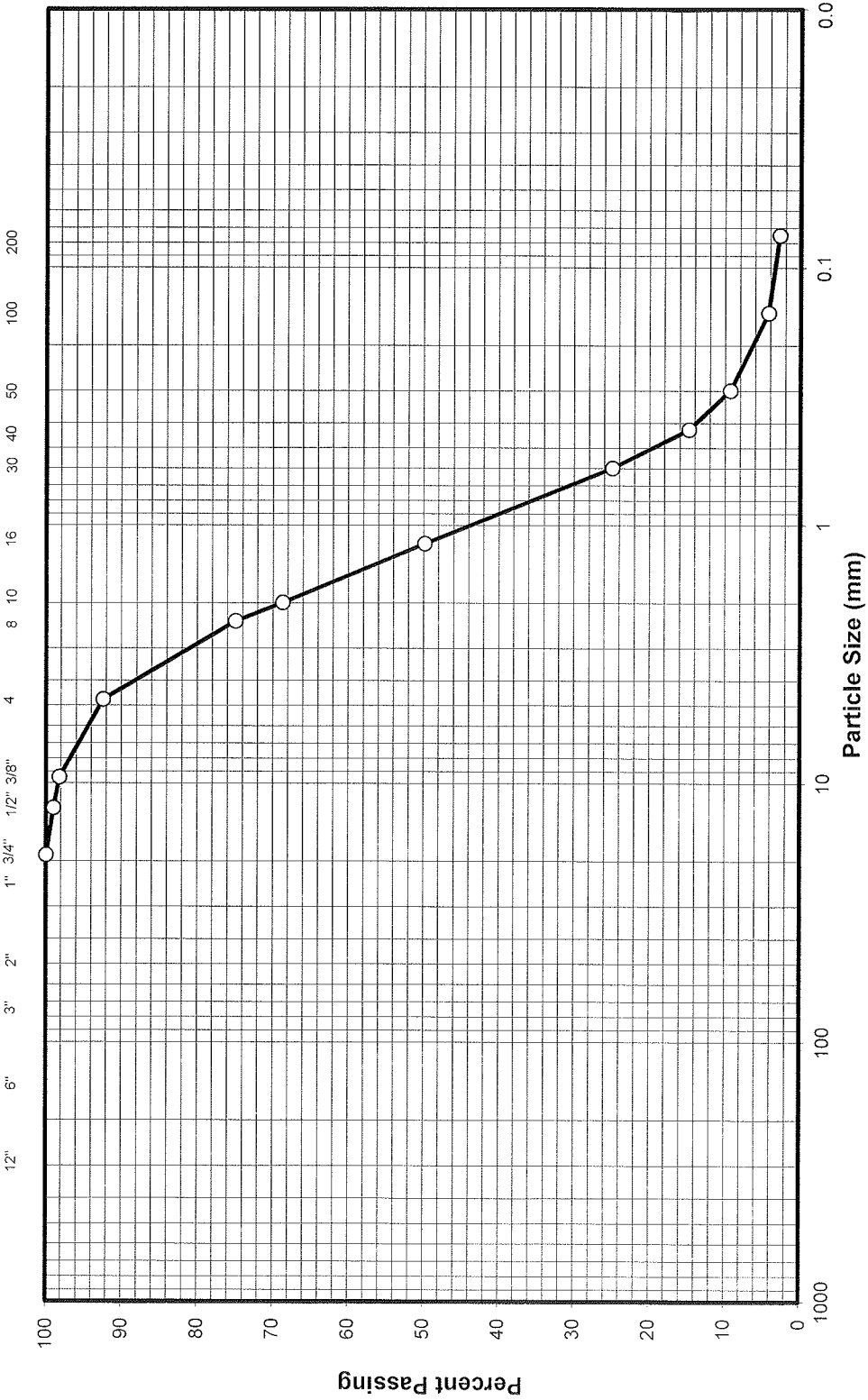

Gravel (%)	8	LL	NV	Project Name:	Hampden Heights Phase 2
Sand (%)	89	PL	NP	Sample ID:	B-2
Fines (%)	3	PI	NP	Sample Depth (ft.):	15
Sample Description:	A-1-b (0) / SP				



Yeh & Associates, Inc.
Geotechnical Engineering Consultants

SIEVE ANALYSIS

Drawn By:	MA	Project No.:	213-091
Checked By:	Jere	Date:	02/06/14
Figure No.:	-		

Corps of Engineers 404 Permit



DEPARTMENT OF THE ARMY
CORPS OF ENGINEERS, OMAHA DISTRICT
DENVER REGULATORY OFFICE, 9307 SOUTH WADSWORTH BOULEVARD
LITTLETON, COLORADO 80128-6901

May 22, 2014

Mr. Dave Evans
Denver Public Schools
1617 S. Acoma St.
Denver, CO 80223

**RE: Construction of a New Stormwater System, Cherry Creek, Denver County, CO
Corps File No. NWO-2014-1148-DEN**

Dear Mr. Evans:

Reference is made to the above-mentioned project, submitted on your behalf by PKM Design Group. The Denver Public Schools proposes constructing a new stormwater system adjacent to Cherry Creek on the west side of South Havana Street Bridge. The project is located in the City of Denver, in Section 34, Township 4 South, Range 67 West, Denver County, Colorado. This office has determined that the work will permanently impact 0.09 acre of waters of the U.S.

Based on the information provided, this office has determined that the work within Colorado is authorized by the **Department of the Army Nationwide Permit No. 43**, found in the February 21, 2012, Federal Register. Enclosed is a fact sheet, which fully describes this Nationwide Permit and lists the General Conditions and Colorado Regional Conditions, which must be adhered to for this authorization to remain valid.

Although an Individual Department of the Army permit will not be required for this work, this does not eliminate the requirement that any other applicable Federal, state, tribal or local permits be obtained as required. Please be advised that deviations from the original plans and specifications of this project could require additional authorization from this office.

The applicant is responsible for all work accomplished in accordance with the terms and conditions of the nationwide permit. If a contractor or other authorized representative will be accomplishing the work authorized by the nationwide permit on behalf of the applicant, it is strongly recommended that they be provided a copy of this letter and the attached conditions so that they are aware of the limitations of the applicable nationwide permit. Any activity which fails to comply with all the terms and conditions of the nationwide permit will be considered unauthorized and subject to appropriate enforcement action.

This verification is valid until March 18, 2017 (expiration Date). In compliance with General Condition 30, the attached "Certification of Completed Work" form (blue) must be signed and returned to this office upon completion of the authorized work and any required mitigation.

Should anyone at any time become aware that either an endangered and/or threatened species or its critical habitat exists within the project area, this office must be notified immediately.

The Omaha District, Regulatory Branch is committed to providing quality and timely service to our customers. In an effort to improve customer service, please take a moment to complete our Customer Service Survey found on our website at http://corpsmapu.usace.army.mil/cm_apex/f?p=regulatory_survey. If you do not have Internet access, you may call and request a paper copy of the survey that you can complete and return to us by mail or fax (Completing the survey is a voluntary action).

If there are any questions call Michael Stanley of my office at (303) 979-4120 and reference **Corps File No. NWO-2014-1148-DEN**.

Sincerely,



Kiel Downing
Chief, Denver Regulatory Office

Enclosures

Copies Furnished:

U.S. Fish & Wildlife Service
Colorado Department of Public Health & Environment
Environmental Protection Agency
Colorado Parks and Wildlife

Chuck Schrader
PKM Design Group
7353 S. Alton Way, Suite A125
Centennial, CO 80112

REVISIONS TO SPECIFICATIONS

REVISION OF STANDARD CONSTRUCTION SPECIFICATION 11.0 STRUCTURES AND APPURTENANCES

Section 22.0 of the Detail and Technical Specifications is hereby revised for this project as follows:

11.0.1 General

In subsection 11.0.1 add the following:

All concrete shall have a minimum compressive strength of 4,500 PSI at 28 days with 5-7% entrained air and Type II Cement unless noted otherwise.

REVISION OF STANDARD CONSTRUCTION SPECIFICATION 21.0 SPRINKLER SYSTEMS

Section 21.0 of the Detail and Technical Specifications is to be replaced with Denver Parks and Recreation Standard Specification 02810 Irrigation System.

Revisions to Specifications

REVISION OF STANDARD CONSTRUCTION SPECIFICATION 23.0 STORM WATER MANAGEMENT

Section 23.0 of the Detail and Technical Specifications is hereby revised for this project as follows:

In subsection 23.01.4 add the following:

The Construction Activities Stormwater Discharge Permit (CASDP) EC-2013-170 currently held by the DPS contractor needs to be amended to include the Phase III scope of work. Approval of the Erosion Control Permit will require submittal and approval of a Stormwater Management Plan and Narrative Information Worksheet. All submitted documents shall follow CCD guidelines set forth in the Construction Activities Stormwater Manual (CASM) found in the following link on the CCD Website:

<http://www.denvergov.org/wastewatermanagement/WastewaterManagement/EngineeringandPermits/ErosionControl/tabid/442674/Default.aspx>.

Exhibit B

INSURANCE: At all times during the term of this Agreement, including any renewals or extensions, School District No. 1 in the City and County of Denver and the State of Colorado shall maintain such insurance, by commercial policy or self-insurance, as is necessary to meet its liabilities under the CGIA. This obligation shall survive the termination of this Agreement

Contractors doing business under this Agreement shall carry the following insurance:

(1) **General Conditions:** Contractor agrees to secure, at or before the time of execution of this Agreement, the following insurance covering all operations, goods or services provided pursuant to this Agreement. Contractor shall keep the required insurance coverage in force at all times during the term of the Agreement, or any extension thereof, during any warranty period, and for three (3) years after termination of the Agreement. The required insurance shall be underwritten by an insurer licensed or authorized to do business in Colorado and rated by A.M. Best Company as "A-"VIII or better. Each policy shall contain a valid provision or endorsement requiring notification to the City in the event any of the required policies be canceled or non-renewed before the expiration date thereof. Such written notice shall be sent to the parties identified in the Notices section of this Agreement. Such notice shall reference the City contract number listed on the signature page of this Agreement. Said notice shall be sent thirty (30) days prior to such cancellation or non-renewal unless due to non-payment of premiums for which notice shall be sent ten (10) days prior. If such written notice is unavailable from the insurer, contractor shall provide written notice of cancellation, non-renewal and any reduction in coverage to the parties identified in the Notices section by certified mail, return receipt requested within three (3) business days of such notice by its insurer(s) and referencing the City's contract number. If any policy is in excess of a deductible or self-insured retention, the City must be notified by the Contractor. Contractor shall be responsible for the payment of any deductible or self-insured retention. The insurance coverages specified in this Agreement are the minimum requirements, and these requirements do not lessen or limit the liability of the Contractor. The Contractor shall maintain, at its own expense, any additional kinds or amounts of insurance that it may deem necessary to cover its obligations and liabilities under this Agreement.

(2) **Proof of Insurance:** Contractor shall provide a copy of this Agreement to its insurance agent or broker. Contractor may not commence services or work relating to the Agreement prior to placement of coverages required under this Agreement. Contractor certifies that the certificate of insurance attached as Exhibit , preferably an ACORD certificate, complies with all insurance requirements of this Agreement. The City requests that the City's contract number be referenced on the Certificate. The City's acceptance of a certificate of insurance or other proof of insurance that does not comply with all insurance requirements set forth in this Agreement shall not act as a waiver of Contractor's breach of this Agreement or of any of the City's rights or remedies under this Agreement. The City's Risk Management Office may require additional proof of insurance, including but not limited to policies and endorsements.

(3) **Additional Insureds:** For Commercial General Liability, Auto Liability and Excess Liability/Umbrella, Contractor and subcontractor's insurer(s) shall name the City and County of Denver, its elected and appointed officials, employees and volunteers as additional insured.

(4) **Waiver of Subrogation:** For all coverages required under this Agreement, Contractor's insurer shall waive subrogation rights against the City.

(5) **Subcontractors and Subconsultants:** All subcontractors and subconsultants (including independent contractors, suppliers or other entities providing goods or services

required by this Agreement) shall be subject to all of the requirements herein and shall procure and maintain the same coverages required of the Contractor. Contractor shall include all such subcontractors as additional insured under its policies (with the exception of Workers' Compensation) or shall ensure that all such subcontractors and subconsultants maintain the required coverages. Contractor agrees to provide proof of insurance for all such subcontractors and subconsultants upon request by the City.

(6) Workers' Compensation/Employer's Liability Insurance: Contractor shall maintain the coverage as required by statute for each work location and shall maintain Employer's Liability insurance with limits of \$100,000 per occurrence for each bodily injury claim, \$100,000 per occurrence for each bodily injury caused by disease claim, and \$500,000 aggregate for all bodily injuries caused by disease claims. Contractor expressly represents to the City, as a material representation upon which the City is relying in entering into this Agreement, that none of the Contractor's officers or employees who may be eligible under any statute or law to reject Workers' Compensation Insurance shall effect such rejection during any part of the term of this Agreement, and that any such rejections previously effected, have been revoked as of the date Contractor executes this Agreement.

(7) Commercial General Liability: Contractor shall maintain a Commercial General Liability insurance policy with limits of \$1,000,000 for each occurrence, \$1,000,000 for each personal and advertising injury claim, \$2,000,000 products and completed operations aggregate, and \$2,000,000 policy aggregate.

(8) Business Automobile Liability: Contractor shall maintain Business Automobile Liability with limits of \$1,000,000 combined single limit applicable to all owned, hired and non-owned vehicles used in performing services under this Agreement

(9) Additional Provisions:

(a) For Commercial General Liability and Excess Liability, the policies must provide the following:

- (i) That this Agreement is an Insured Contract under the policy;
- (ii) Defense costs are outside the limits of liability;
- (iii) A severability of interests or separation of insureds provision (no insured vs. insured exclusion); and
- (iv) A provision that coverage is primary and non-contributory with other coverage or self-insurance maintained by the City.

(b) For claims-made coverage:

- (i) The retroactive date must be on or before the contract date or the first date when any goods or services were provided to the City, whichever is earlier

(c) Contractor shall advise the City in the event any general aggregate or other aggregate limits are reduced below the required per occurrence limits. At their own expense, and where such general aggregate or other aggregate limits have been reduced below the required per occurrence limit, the Contractor will procure such per occurrence limits and furnish a new certificate of insurance showing such coverage is in force.

Defense and Indemnification

- (a) To the fullest extent permitted by law, the _____ hereby agrees to defend, indemnify, reimburse and hold harmless City, its appointed and elected officials, agents and employees for, from and against all liabilities, claims, judgments, suits or demands for damages to persons or property arising out of, resulting from, or related to the work performed under this Agreement that are due to the negligence or fault of the _____ or the _____'s agents, representatives, subcontractors, or suppliers ("Claims"). This indemnity shall be interpreted in the broadest possible manner consistent with the applicable law to indemnify the City.
- (b) _____'s duty to defend and indemnify City shall arise at the time written notice of the Claim is first provided to City regardless of whether suit has been filed and even if _____ is not named as a Defendant.
- (c) _____ will defend any and all Claims which may be brought or threatened against City and will pay on behalf of City any expenses incurred by reason of such Claims including, but not limited to, court costs and attorney fees incurred in defending and investigating such Claims or seeking to enforce this indemnity obligation. Such payments on behalf of City shall be in addition to any other legal remedies available to City and shall not be considered City's exclusive remedy.
- (d) Insurance coverage requirements specified in this Agreement shall in no way lessen or limit the liability of the _____ under the terms of this indemnification obligation. The _____ shall obtain, at its own expense, any additional insurance that it deems necessary for the City's protection.
- (e) This defense and indemnification obligation shall survive the expiration or termination of this Agreement.

EXHIBIT C

LAND DESCRIPTION

LOCATED IN THE SOUTHEAST QUARTER OF SECTION 34, TOWNSHIP 4 SOUTH,
RANGE 67 WEST OF THE 6TH PRINCIPAL MERIDIAN,
CITY AND COUNTY OF DENVER, STATE OF COLORADO
SHEET 1 OF 4

A PARCEL OF LAND LOCATED IN THE SOUTHEAST QUARTER OF SECTION 34,
TOWNSHIP 4 SOUTH, RANGE 67 WEST OF THE 6TH PRINCIPAL MERIDIAN, CITY
AND COUNTY OF DENVER, STATE OF COLORADO, BEING A PORTION OF THAT
PARCEL OF LAND DESCRIBED IN RECEPTION NUMBER 2013100201, CLERK
AND RECORDER'S RECORDS, CITY AND COUNTY OF DENVER, BEING MORE
PARTICULARLY DESCRIBED AS FOLLOWS:

COMMENCING AT THE EAST QUARTER CORNER OF SAID SECTION 34, THENCE
SOUTH 26°01'08" WEST, A DISTANCE OF 390.18 FEET TO A POINT ON THE
BOUNDARY OF THAT UNPLATTED PROPERTY OWNED BY DENVER PUBLIC
SCHOOLS AS DESCRIBED IN THAT DOCUMENT RECORDED AT RECEPTION
NUMBER 2013100201, CLERK AND RECORDER'S RECORDS, CITY AND COUNTY
OF DENVER, SAID POINT ALSO BEING ON THE WESTERLY RIGHT-OF-WAY OF
SOUTH HAVANA STREET, ALSO BEING COLORADO STATE HIGHWAY 30, SAID
POINT BEING THE **POINT OF BEGINNING**;

THENCE ALONG THE NORTHERLY BOUNDARY OF SAID PARCEL DESCRIBED IN
RECEPTION NUMBER 2013100201 THE FOLLOWING THREE COURSES;

THENCE NORTH 70°13'17" WEST A DISTANCE OF 224.71 FEET;
THENCE NORTH 27°24'49" WEST A DISTANCE OF 180.00 FEET;
THENCE SOUTH 66°07'52" WEST A DISTANCE OF 57.20 FEET TO A NON-
TANGENT CURVE;

THENCE DEPARTING SAID NORTHERLY BOUNDARY AND ON A NON-TANGENT
CURVE CONCAVE TO THE NORTHEAST HAVING A RADIUS OF 210.00 FEET, A
CENTRAL ANGLE OF 23°17'13", AND A CHORD WHICH BEARS SOUTH 37°18'48"
EAST A DISTANCE OF 84.76 FEET, AN ARC DISTANCE OF 85.35 FEET TO A
POINT OF NON-TANGENCY;

THENCE SOUTH 49°14'17" EAST A DISTANCE OF 73.85 FEET TO A NON-
TANGENT CURVE;

THENCE ON A NON-TANGENT CURVE CONCAVE TO THE SOUTHWEST HAVING
A RADIUS OF 290.00 FEET, A CENTRAL ANGLE OF 10°33'59", AND A CHORD
WHICH BEARS SOUTH 44°14'09" EAST A DISTANCE OF 53.41 FEET, AN ARC
DISTANCE OF 53.48 FEET TO A POINT OF COMPOUND CURVE:

THENCE ON A NON-TANGENT CURVE CONCAVE TO THE SOUTHWEST HAVING
A RADIUS OF 431.01 FEET, A CENTRAL ANGLE OF 20°34'07", AND A CHORD

LAND DESCRIPTION

LOCATED IN THE SOUTHEAST QUARTER OF SECTION 34, TOWNSHIP 4 SOUTH,
RANGE 67 WEST OF THE 6TH PRINCIPAL MERIDIAN,
CITY AND COUNTY OF DENVER, STATE OF COLORADO
SHEET 2 OF 4

WHICH BEARS SOUTH 28°40'06" EAST A DISTANCE OF 153.90 FEET, AN ARC DISTANCE OF 154.73 FEET TO A POINT OF NON-TANGENCY;
THENCE SOUTH 32°57'55" WEST A DISTANCE OF 5.14 FEET TO A NON-TANGENT CURVE;
THENCE ON A NON-TANGENT CURVE CONCAVE TO THE NORTHEAST HAVING A RADIUS OF 37.00 FEET, A CENTRAL ANGLE OF 67°19'57", AND A CHORD WHICH BEARS SOUTH 51°37'12" EAST A DISTANCE OF 41.02 FEET, AN ARC DISTANCE OF 43.48 FEET TO A POINT OF REVERSE CURVE;
THENCE ON A NON-TANGENT CURVE CONCAVE TO THE SOUTHWEST HAVING A RADIUS OF 54.93 FEET, A CENTRAL ANGLE OF 70°37'57", AND A CHORD WHICH BEARS SOUTH 49°58'12" EAST A DISTANCE OF 63.51 FEET, AN ARC DISTANCE OF 67.72 FEET TO A POINT OF REVERSE CURVE;
THENCE ON A NON-TANGENT CURVE CONCAVE TO THE NORTHEAST HAVING A RADIUS OF 30532.18 FEET, A CENTRAL ANGLE OF 00°03'32", AND A CHORD WHICH BEARS SOUTH 14°40'59" EAST A DISTANCE OF 31.33 FEET, AN ARC DISTANCE OF 31.33 FEET TO A POINT OF COMPOUND CURVE;
THENCE ON A NON-TANGENT CURVE CONCAVE TO THE NORTHEAST HAVING A RADIUS OF 33213.00 FEET, A CENTRAL ANGLE OF 00°03'12", AND A CHORD WHICH BEARS SOUTH 19°42'59" EAST A DISTANCE OF 30.90 FEET, AN ARC DISTANCE OF 30.90 FEET TO A POINT OF COMPOUND CURVE;
THENCE ON A NON-TANGENT CURVE CONCAVE TO THE NORTHEAST HAVING A RADIUS OF 22.00 FEET, A CENTRAL ANGLE OF 69°32'00", AND A CHORD WHICH BEARS SOUTH 54°30'34" EAST A DISTANCE OF 25.09 FEET, AN ARC DISTANCE OF 26.70 FEET TO A POINT OF NON-TANGENCY;
THENCE SOUTH 89°09'11" EAST TO THE EASTERLY BOUNDARY OF SAID PARCEL DESCRIBED IN RECEPTION NUMBER 2013100201, AND ALSO BEING THE WESTERLY RIGHT-OF-WAY OF SOUTH HAVANA STREET, A DISTANCE OF 8.26 FEET;
THENCE NORTH 00°49'28" EAST ALONG SAID WESTERLY BOUNDARY AND RIGHT-OF-WAY A DISTANCE OF 220.99 FEET TO THE **POINT OF BEGINNING**.

CONTAINING 32509 SQUARE FEET, OR 0.746 ACRES, MORE OR LESS.

LAND DESCRIPTION

LOCATED IN THE SOUTHEAST QUARTER OF SECTION 34, TOWNSHIP 4 SOUTH,
RANGE 67 WEST OF THE 6TH PRINCIPAL MERIDIAN,
CITY AND COUNTY OF DENVER, STATE OF COLORADO
SHEET 3 OF 4

BASIS OF BEARINGS: BEARINGS ARE BASED ON A BEARING OF SOUTH
00°02'10" WEST ALONG THE EASTERLY LINE OF SAID SOUTHEAST QUARTER
OF SECTION 34, AS SHOWN ON THAT PERMANENT SEWER EASEMENT
RECORDED AT RECEPTION NUMBER 2015012744, CLERK AND RECORDER'S
RECORDS, CITY AND COUNTY OF DENVER.

PREPARED FOR AND ON BEHALF OF
THE CITY AND COUNTY OF DENVER
201 WEST COLFAX AVENUE
DENVER, CO 80202
DATE: AUGUST 14, 2015
BY: RONALD T. ELLIS, PLS 14592



LAND DESCRIPTION

LOCATED IN THE SOUTHEAST QUARTER OF SECTION 34, TOWNSHIP 4 SOUTH, RANGE 68 WEST
OF THE 6TH PRINCIPAL MERIDIAN, CITY AND COUNTY OF DENVER, STATE OF COLORADO

SHEET 4 OF 4

E 1/4 COR. SEC. 34, T4S, R67W

FOUND 1" REBAR DENVER
RANGE POINT IN RANGE BOX
(POINT OF COMMENCEMENT)

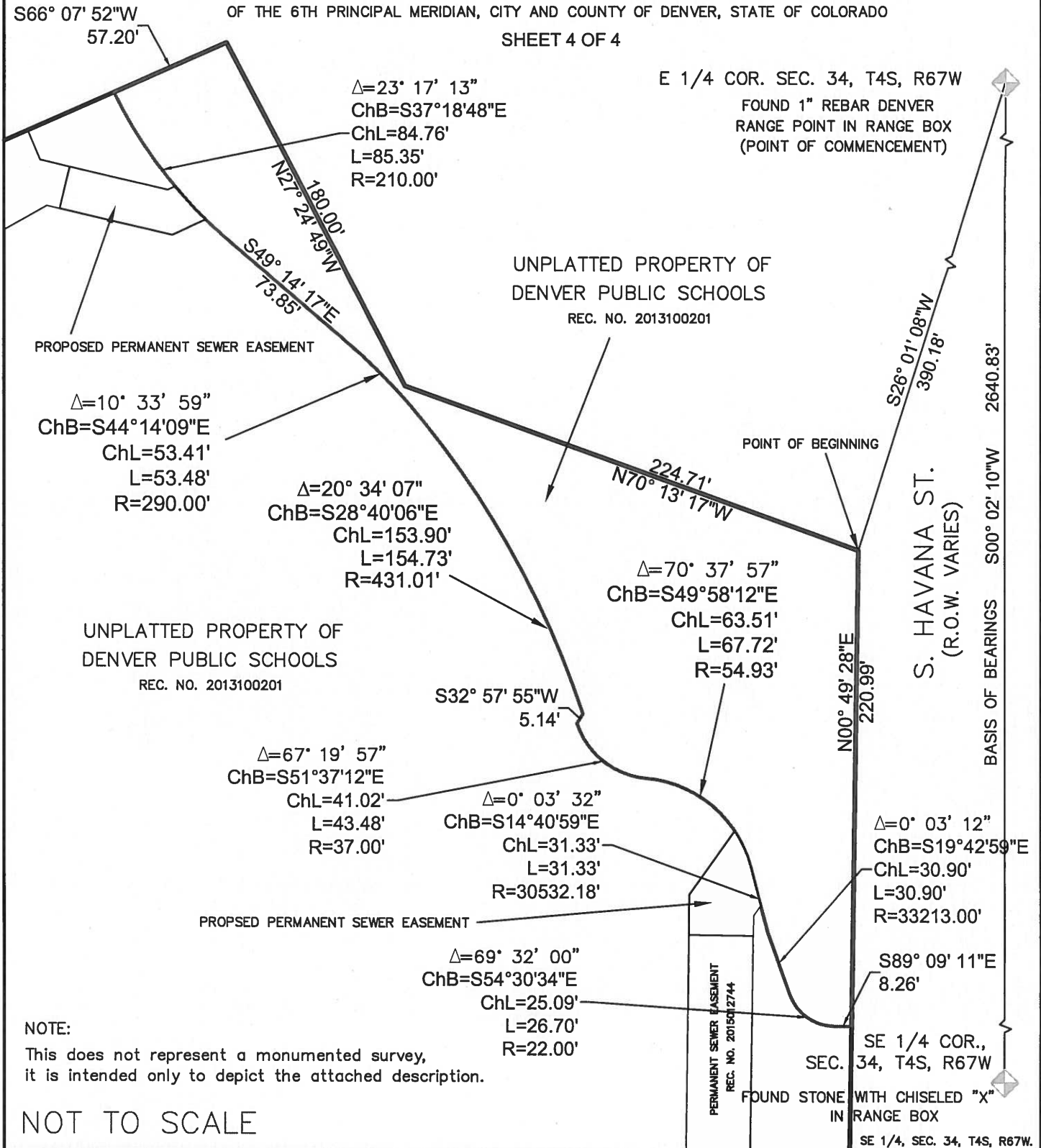

PROPOSED PERMANENT SEWER EASEMENT

UNPLATTED PROPERTY OF
DENVER PUBLIC SCHOOLS
REC. NO. 2013100201

UNPLATTED PROPERTY OF
DENVER PUBLIC SCHOOLS
REC. NO. 2013100201

PROPOSED PERMANENT SEWER EASEMENT

PERMANENT SEWER EASEMENT
REC. NO. 2015012744

SE 1/4 COR.,
SEC. 34, T4S, R67W
FOUND STONE WITH CHISELED "X"
IN RANGE BOX
SE 1/4, SEC. 34, T4S, R67W.

$\Delta=10^{\circ} 33' 59''$
ChB=S44°14'09"E
ChL=53.41'
L=53.48'
R=290.00'

$\Delta=20^{\circ} 34' 07''$
ChB=S28°40'06"E
ChL=153.90'
L=154.73'
R=431.01'

$\Delta=70^{\circ} 37' 57''$
ChB=S49°58'12"E
ChL=63.51'
L=67.72'
R=54.93'

$\Delta=67^{\circ} 19' 57''$
ChB=S51°37'12"E
ChL=41.02'
L=43.48'
R=37.00'

$\Delta=0^{\circ} 03' 32''$
ChB=S14°40'59"E
ChL=31.33'
L=31.33'
R=30532.18'

$\Delta=0^{\circ} 03' 12''$
ChB=S19°42'59"E
ChL=30.90'
L=30.90'
R=33213.00'

$\Delta=69^{\circ} 32' 00''$
ChB=S54°30'34"E
ChL=25.09'
L=26.70'
R=22.00'

NOTE:
This does not represent a monumented survey,
it is intended only to depict the attached description.

NOT TO SCALE



Land Description

CITY & COUNTY OF
DENVER PUBLIC WORKS
ROW/SURVEY DEPT.

DATE: 8-13-2015	SCALE: NO SCALE	DRAWN BY: GY EDITED BY: RT	SHEET NO: 1 OF 1	DRAWING NO:
--------------------	--------------------	-------------------------------	---------------------	-------------

PERMANENT SEWER EASEMENT

LOCATED IN THE SOUTHEAST QUARTER OF SECTION 34, TOWNSHIP 4 SOUTH,
RANGE 67 WEST OF THE 6TH PRINCIPAL MERIDIAN,
CITY AND COUNTY OF DENVER, STATE OF COLORADO
SHEET 1 OF 3

AN EASEMENT FOR STORM SEWER UTILITY OVER AND ACROSS A PARCEL OF LAND LOCATED IN THE SOUTHEAST QUARTER OF SECTION 34, TOWNSHIP 4 SOUTH, RANGE 67 WEST OF THE 6TH PRINCIPAL MERIDIAN, CITY AND COUNTY OF DENVER, STATE OF COLORADO, BEING MORE PARTICULARLY DESCRIBED AS FOLLOWS:

COMMENCING AT THE EAST QUARTER CORNER OF SAID SECTION 34, THENCE SOUTH 74°24'37" WEST, A DISTANCE OF 578.94 FEET TO A POINT ON THE BOUNDARY OF THAT UNPLATTED PROPERTY OWNED BY DENVER PUBLIC SCHOOLS AS DESCRIBED IN THAT DOCUMENT RECORDED AT RECEPTION NUMBER 2013100201, CLERK AND RECORDER'S RECORDS, CITY AND COUNTY OF DENVER, SAID POINT ALSO BEING THE POINT OF BEGINNING OF THAT PERMANENT SEWER EASEMENT RECORDED AT RECEPTION NUMBER 2015012744, CLERK AND RECORDER'S RECORDS, CITY AND COUNTY OF DENVER;

THENCE ALONG THE WESTERLY PORTION OF SAID EASEMENT THE FOLLOWING TWO COURSES;

THENCE SOUTH 22°47'28" EAST A DISTANCE OF 15.03 FEET;
THENCE SOUTH 76°36'35" EAST A DISTANCE OF 13.93 FEET TO THE **TRUE POINT OF BEGINNING**;
THENCE SOUTH 13°23'25" WEST AND CONTINUING ALONG THE BOUNDARY OF SAID EASEMENT A DISTANCE OF 20.00 FEET;
THENCE DEPARTING SAID EASEMENT SOUTH 76°36'35" EAST A DISTANCE OF 53.65 FEET;
THENCE NORTH 65°06'07" EAST A DISTANCE OF 17.16 FEET TO A NON-TANGENT CURVE;
THENCE ON A NON-TANGENT CURVE CONCAVE TO THE NORTHEAST HAVING A RADIUS OF 210.00 FEET, A CENTRAL ANGLE OF 5°44'18", AND A CHORD WHICH BEARS NORTH 42°50'51" WEST A DISTANCE OF 21.02 FEET, AN ARC DISTANCE OF 21.03 FEET TO A POINT OF NON-TANGENCY;
THENCE SOUTH 65°06'07" WEST A DISTANCE OF 3.74 FEET;
THENCE NORTH 76°36'35" WEST A DISTANCE OF 46.70 FEET TO THE **TRUE POINT OF BEGINNING**.

CONTAINING 1209 SQUARE FEET, OR 0.028 ACRES, MORE OR LESS.

PERMANENT SEWER EASEMENT

LOCATED IN THE SOUTHEAST QUARTER OF SECTION 34, TOWNSHIP 4 SOUTH,
RANGE 67 WEST OF THE 6TH PRINCIPAL MERIDIAN,
CITY AND COUNTY OF DENVER, STATE OF COLORADO
SHEET 2 OF 3

BASIS OF BEARINGS: BEARINGS ARE BASED ON A BEARING OF SOUTH
00°02'10" WEST ALONG THE EASTERLY LINE OF SAID SOUTHEAST QUARTER
OF SECTION 34, AS SHOWN ON THAT PERMANENT SEWER EASEMENT
RECORDED AT RECEPTION NUMBER 2015012744, CLERK AND RECORDER'S
RECORDS, CITY AND COUNTY OF DENVER.

PREPARED FOR AND ON BEHALF OF
THE CITY AND COUNTY OF DENVER
201 WEST COLFAX AVENUE
DENVER, CO 80202
DATE: AUGUST 14, 2015
BY: RONALD T. ELLIS, PLS 14592



PERMANENT SEWER EASEMENT

LOCATED IN THE SOUTHEAST QUARTER OF SECTION 34, TOWNSHIP 4 SOUTH, RANGE 68 WEST
OF THE 6TH PRINCIPAL MERIDIAN, CITY AND COUNTY OF DENVER, STATE OF COLORADO

SHEET 3 OF 3

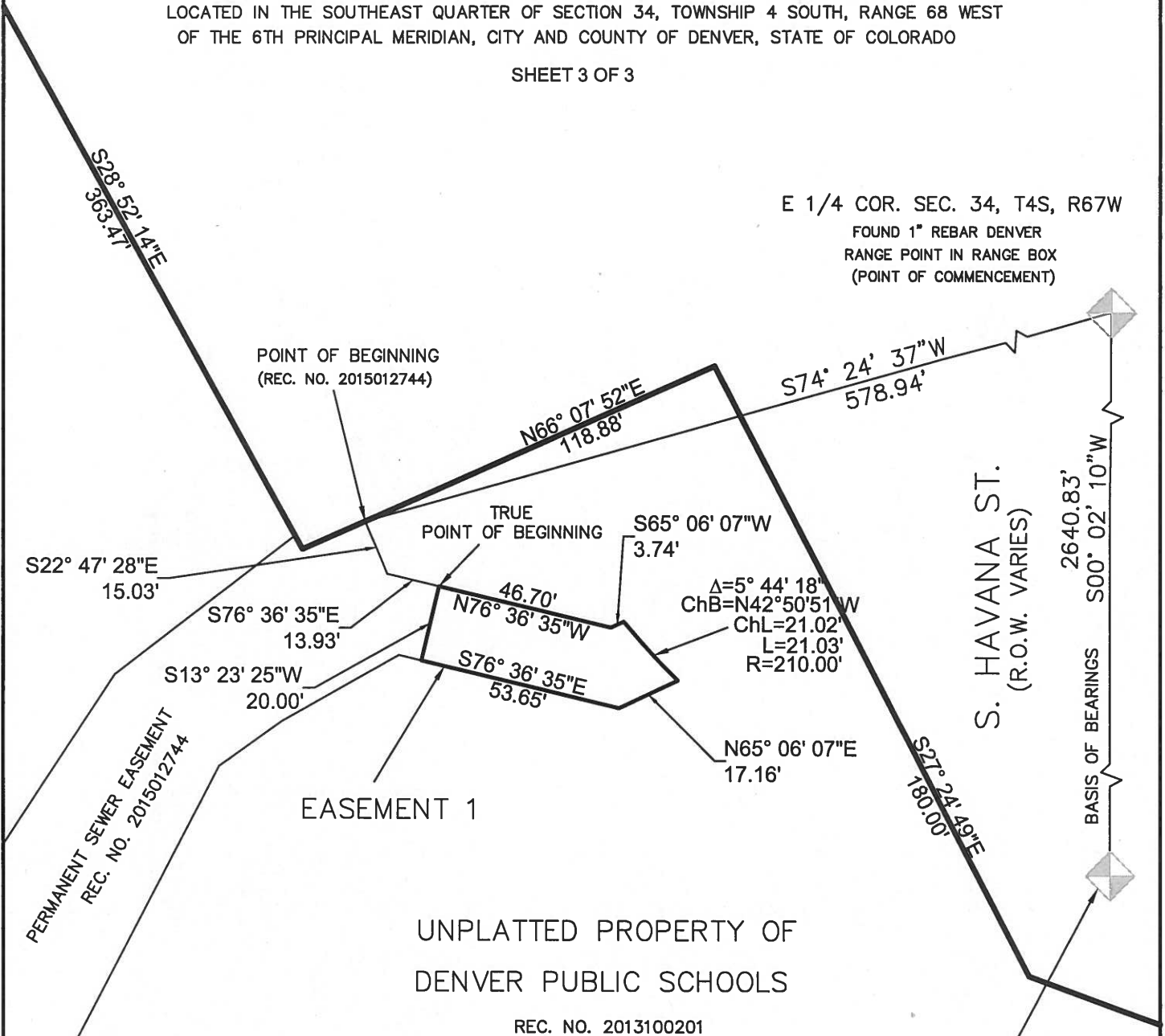

E 1/4 COR. SEC. 34, T4S, R67W
FOUND 1" REBAR DENVER
RANGE POINT IN RANGE BOX
(POINT OF COMMENCEMENT)

POINT OF BEGINNING
(REC. NO. 2015012744)

TRUE
POINT OF BEGINNING

EASEMENT 1

UNPLATTED PROPERTY OF
DENVER PUBLIC SCHOOLS

REC. NO. 2013100201

S. HAVANA ST.
(R.O.W. VARIES)

SE 1/4 COR.,
SEC. 34, T4S, R67W
FOUND STONE WITH CHISELED "X"
IN RANGE BOX

NOTE:
This does not represent a monumented survey,
it is intended only to depict the attached description.

NOT TO SCALE

SE 1/4, SEC. 34, T4S, R67W



Permanent Sewer Easement

CITY & COUNTY OF
DENVER PUBLIC WORKS
ROW/SURVEY DEPT.

Permanent Sewer Easement

DATE: 8-13-2015	SCALE: NO SCALE	DRAWN BY: GY EDITED BY: RT	SHEET NO: 1 OF 1	DRAWING NO:
--------------------	--------------------	-------------------------------	---------------------	----------------

PERMANENT SEWER EASEMENT

LOCATED IN THE SOUTHEAST QUARTER OF SECTION 34, TOWNSHIP 4 SOUTH,
RANGE 67 WEST OF THE 6TH PRINCIPAL MERIDIAN,
CITY AND COUNTY OF DENVER, STATE OF COLORADO
SHEET 1 OF 3

AN EASEMENT FOR STORM SEWER UTILITY OVER AND ACROSS A PARCEL OF LAND LOCATED IN THE SOUTHEAST QUARTER OF SECTION 34, TOWNSHIP 4 SOUTH, RANGE 67 WEST OF THE 6TH PRINCIPAL MERIDIAN, CITY AND COUNTY OF DENVER, STATE OF COLORADO, BEING MORE PARTICULARLY DESCRIBED AS FOLLOWS:

COMMENCING AT THE EAST QUARTER CORNER OF SAID SECTION 34, THENCE SOUTH 25°18'20" WEST, A DISTANCE OF 585.36 FEET TO THE NORTHWEST CORNER OF THE EASTERLY PORTION OF THAT PERMANENT SEWER EASEMENT RECORDED AT RECEPTION NUMBER 2015012744, CLERK AND RECORDER'S RECORDS, CITY AND COUNTY OF DENVER, SAID POINT ALSO BEING THE **POINT OF BEGINNING**;

THENCE SOUTH 89°18'56" EAST ALONG THE NORTHERLY LINE OF SAID EASTERLY PORTION OF SAID EASEMENT A DISTANCE OF 30.00 FEET TO THE NORTHEAST CORNER OF SAID EASTERLY PORTION OF SAID EASEMENT;

THENCE DEPARTING SAID EASEMENT NORTH 00°41'07" EAST A DISTANCE OF 9.23 FEET;

THENCE NORTH 35°37'41" EAST A DISTANCE OF 5.86 FEET;

THENCE NORTH 14°40'16" WEST A DISTANCE OF 18.67 FEET TO A POINT OF CURVATURE;

THENCE ON A CURVE CONCAVE TO THE SOUTHWEST HAVING A RADIUS OF 54.93 FEET, A CENTRAL ANGLE OF 18°57'37", AND A CHORD WHICH BEARS NORTH 24°08'02" WEST A DISTANCE OF 18.10 FEET, AN ARC DISTANCE OF 18.18 FEET TO A POINT OF NON-TANGENCY;

THENCE SOUTH 35°37'41" WEST A DISTANCE OF 36.34 FEET;

THENCE SOUTH 00°41'07" WEST A DISTANCE OF 18.68 FEET TO THE **POINT OF BEGINNING**.

CONTAINING 1089 SQUARE FEET, OR 0.025 ACRES, MORE OR LESS.

PERMANENT SEWER EASEMENT

LOCATED IN THE SOUTHEAST QUARTER OF SECTION 34, TOWNSHIP 4 SOUTH,
RANGE 67 WEST OF THE 6TH PRINCIPAL MERIDIAN,
CITY AND COUNTY OF DENVER, STATE OF COLORADO
SHEET 2 OF 3

BASIS OF BEARINGS: BEARINGS ARE BASED ON A BEARING OF SOUTH
00°02'10" WEST ALONG THE EASTERLY LINE OF SAID SOUTHEAST QUARTER
OF SECTION 34, AS SHOWN ON THAT PERMANENT SEWER EASEMENT
RECORDED AT RECEPTION NUMBER 2015012744, CLERK AND RECORDER'S
RECORDS, CITY AND COUNTY OF DENVER.

PREPARED FOR AND ON BEHALF OF
THE CITY AND COUNTY OF DENVER
201 WEST COLFAX AVENUE
DENVER, CO 80202
DATE: AUGUST 14, 2015
BY: RONALD T. ELLIS, PLS 14592



PERMANENT SEWER EASEMENT

LOCATED IN THE SOUTHEAST QUARTER OF SECTION 34, TOWNSHIP 4 SOUTH, RANGE 68 WEST
OF THE 6TH PRINCIPAL MERIDIAN, CITY AND COUNTY OF DENVER, STATE OF COLORADO

SHEET 3 OF 3

E 1/4 COR. SEC. 34, T4S, R67W

FOUND 1" REBAR DENVER
RANGE POINT IN RANGE BOX
(POINT OF COMMENCEMENT)

UNPLATTED PROPERTY OF
DENVER PUBLIC SCHOOLS

REC. NO. 2013100201

EASEMENT 2

$\Delta=18^{\circ} 57' 37''$
ChB=N24°08'02"W
ChL=18.10'
L=18.18'
R=54.93'

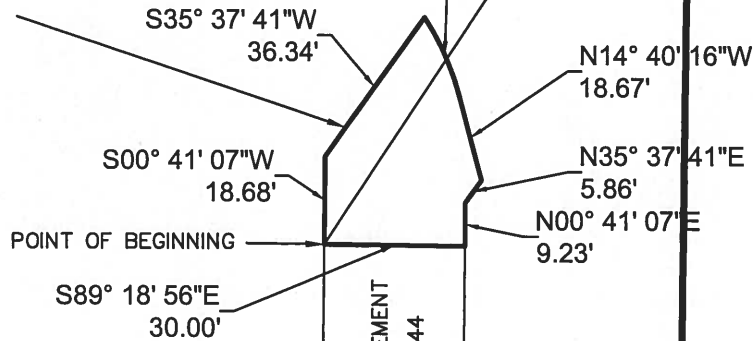

POINT OF BEGINNING

S89° 18' 56"E
30.00'

PERMANENT SEWER EASEMENT
REC. NO. 2015012744

S. HAVANA ST.
(R.O.W. VARIES)

799.81'
S00° 49' 28"W

N14° 40' 16"W
18.67'

N35° 37' 41"E
5.86'

N00° 41' 07"E
9.23'

2640.83'

S00° 02' 10"W

BASIS OF BEARINGS

SE 1/4 COR.,
SEC. 34, T4S, R67W
FOUND STONE WITH CHISELED "X"
IN RANGE BOX

SE 1/4, SEC. 34, T4S, R67W.

NOTE:

This does not represent a monumented survey,
it is intended only to depict the attached description.

NOT TO SCALE



Permanent Sewer Easement

CITY & COUNTY OF
DENVER PUBLIC WORKS
ROW/SURVEY DEPT.

Permanent Sewer Easement

DATE: 8-13-2015	SCALE: NO SCALE	DRAWN BY: GY EDITED BY: RT	SHEET NO: 1 OF 1	DRAWING NO:
--------------------	--------------------	-------------------------------	---------------------	----------------