

# TOWER 160 SUBDIVISION FILING NO. 4

A RESUBDIVISION OF A PORTION OF LOT 3, BLOCK 2, TOWER 160 SUBDIVISION FILING NO. 2  
SITUATED IN THE SOUTHEAST QUARTER OF SECTION 16, TOWNSHIP 3 SOUTH, RANGE 66 WEST OF THE SIXTH PRINCIPAL MERIDIAN,  
CITY AND COUNTY OF DENVER, STATE OF COLORADO.

## DEDICATION

KNOW ALL MEN BY THESE PRESENTS THAT CLAYTON PROPERTIES GROUP II, INC., A COLORADO CORPORATION, AS OWNER, HAS LAID OUT, PLATTED AND SUBDIVIDED INTO BLOCKS, LOTS, AND TRACTS AS SHOWN ON THIS MAP, THE LAND DESCRIBED AS FOLLOWS:

A PORTION OF LOT 3, BLOCK 2, TOWER 160 SUBDIVISION FILING NO. 2 RECORDED ON JUNE 18TH, 2015 AT RECEPTION NO. 2015080690, LYING IN THE SOUTHEAST QUARTER OF SECTION 16, TOWNSHIP 3 SOUTH, RANGE 66 WEST OF THE SIXTH PRINCIPAL MERIDIAN, CITY AND COUNTY OF DENVER, STATE OF COLORADO, BEING MORE PARTICULARLY DESCRIBED AS FOLLOWS:

BEGINNING AT THE SOUTHEASTERLY CORNER OF SAID LOT 3 WHENCE THE EAST QUARTER CORNER OF SAID SECTION 16 BEARS NORTH 23°39'58" EAST, A DISTANCE OF 1714.71 FEET AND THE EAST LINE OF THE SOUTHEAST QUARTER OF SAID SECTION 16 BEARS SOUTH 00°15'23" EAST, A DISTANCE OF 2658.39 FEET WITH ALL BEARINGS CONTAINED HEREIN RELATIVE THERETO;

THENCE ALONG THE SOUTHERLY, WESTERLY AND NORTHERLY BOUNDARY OF SAID LOT 3 THE FOLLOWING THREE (3) COURSES:

1. SOUTH 89°52'55" WEST, A DISTANCE OF 313.97 FEET;
2. NORTH 00°07'05" WEST, A DISTANCE OF 993.88 FEET;
3. SOUTH 89°59'55" EAST, A DISTANCE OF 289.02 FEET TO THE BEGINNING OF A TANGENT CURVE CONCAVE SOUTHWESTERLY HAVING A RADIUS OF 25.00 FEET;

THENCE DEPARTING SAID NORTHERLY BOUNDARY, SOUTHEASTERLY ALONG SAID CURVE THROUGH A CENTRAL ANGLE OF 89°52'50", AN ARC LENGTH OF 39.22 FEET TO THE EASTERLY BOUNDARY OF SAID LOT 3;

THENCE ALONG SAID EASTERLY BOUNDARY, SOUTH 00°07'05" EAST, A DISTANCE OF 968.28 FEET TO THE POINT OF BEGINNING;

CONTAINING AN AREA OF 7.158 ACRES, (311,812 SQUARE FEET), MORE OR LESS.

UNDER THE NAME AND STYLE OF TOWER 160 SUBDIVISION FILING NO. 4, AND BY THESE PRESENTS DO HEREBY DEDICATE TO THE CITY AND COUNTY OF DENVER THE EASEMENTS AND OTHER PUBLIC PLACES HEREON SHOWN AND NOT ALREADY OTHERWISE DEDICATED FOR PUBLIC USE, ALSO TO THE CITY AND COUNTY OF DENVER, APPLICABLE PUBLIC UTILITIES AND TELECOMMUNICATION EASEMENTS AS SHOWN.

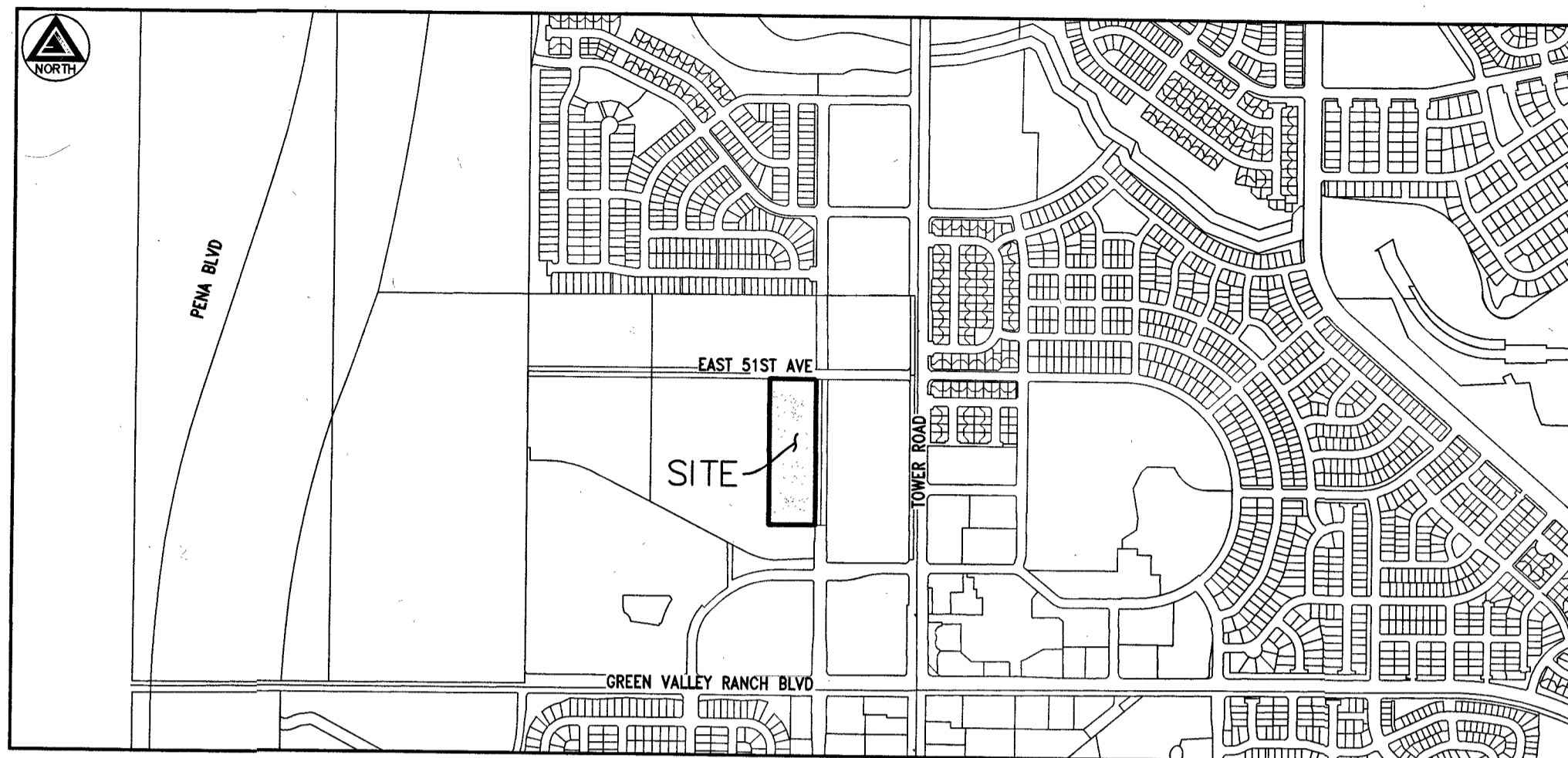

VICINITY MAP  
SCALE 1" = 1000'

## OWNER

CLAYTON PROPERTIES GROUP II, INC., A COLORADO CORPORATION

BY: Patrick H. Hamill DATE: 1/13/2022

NAME: PATRICK H. HAMILL

TITLE: VICE PRESIDENT

STATE OF COLORADO )  
COUNTY OF Denver )SS

## NOTARY

THE FOREGOING INSTRUMENT WAS ACKNOWLEDGED BEFORE ME THIS 13th  
DAY OF January, 2022 BY Patrick H. Hamill

OF CLAYTON PROPERTIES GROUP II, INC., A COLORADO CORPORATION

WITNESS MY HAND AND OFFICIAL SEAL

MY COMMISSION EXPIRES: 11.15.2025

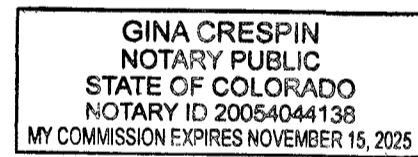

NOTARY PUBLIC: Gina Crespin

## ACCEPTANCE OF TRACTS BY TOWN CENTER METROPOLITAN DISTRICT

TOWN CENTER METROPOLITAN DISTRICT, A QUASI-MUNICIPAL CORPORATION

BY: Brandon S. Wyszynski DATE: JANUARY 12, 2022

NAME: BRANDON S. WYSZYNSKI

TITLE: BOARD PRESIDENT

STATE OF COLORADO )  
COUNTY OF Denver )SS

## NOTARY

THE FOREGOING INSTRUMENT WAS ACKNOWLEDGED BEFORE ME THIS 13th  
DAY OF January, 2022 BY Brandon S. Wyszynski

OF TOWN CENTER METROPOLITAN DISTRICT, A QUASI-MUNICIPAL CORPORATION

WITNESS MY HAND AND OFFICIAL SEAL

MY COMMISSION EXPIRES: 11.15.2025

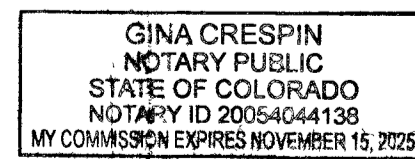

NOTARY PUBLIC: Gina Crespin

## OWNER/DEVELOPER:

CLAYTON PROPERTIES GROUP II, INC.  
DBA. OAKWOOD HOMES  
4908 TOWER ROAD  
DENVER, CO 80249

## SURVEYOR/ENGINEER:

AZTEC CONSULTANTS INC.  
300 EAST MINERAL AVENUE, SUITE 1  
LITTLETON, CO 80122

## DESIGNER:

TERRACINA DESIGN  
10200 E. GIRARD AVE. STE A-314  
DENVER, CO 80231

## GENERAL NOTES

1. THIS SURVEY DOES NOT REPRESENT A TITLE SEARCH BY AZTEC CONSULTANTS, INC. FOR RECORD DOCUMENTS AND DETERMINATION OF OWNERSHIP, EASEMENTS OF RECORD, RIGHTS-OF-WAY AND ENCUMBRANCES, AZTEC CONSULTANTS, INC. RELIED UPON TITLE COMMITMENT ORDER NO. 20000310482 REVISION NO. 9, PREPARED BY STEWART TITLE GUARANTY COMPANY, WITH AN EFFECTIVE DATE OF DECEMBER 13, 2021 AT 5:30 P.M.
2. BEARINGS ARE BASED UPON THE EAST LINE OF THE SOUTHEAST QUARTER OF SECTION 16, TOWNSHIP 3 SOUTH, RANGE 66 WEST OF THE SIXTH PRINCIPAL MERIDIAN AS BEARING SOUTH 00°15'23" EAST BETWEEN THE EAST QUARTER CORNER AND THE SOUTHEAST CORNER OF SAID SECTION 16, BOTH CORNERS BEING MONUMENTED BY A NO. 6 REBAR WITH A 3-1/4" ALUMINUM CAP STAMPED "LUCHETTI SURVEYING PLS 36053 2005" IN A RANGE BOX.
3. ALL STREETS SHOWN WITH THIS PLAT ARE PRIVATE AND WILL BE OWNED AND MAINTAINED BY THE TOWN CENTER METROPOLITAN DISTRICT.
4. ACCORDING TO COLORADO LAW YOU MUST COMMENCE ANY LEGAL ACTION BASED UPON ANY DEFECT IN THIS SURVEY WITHIN THREE YEARS AFTER YOU FIRST DISCOVER SUCH DEFECT. IN NO EVENT MAY ANY ACTION BASED UPON ANY DEFECT IN THIS SURVEY BE COMMENCED MORE THAN TEN YEARS FROM THE DATE OF THE CERTIFICATION SHOWN HEREON.
5. FIVE-FOOT-WIDE NON-EXCLUSIVE EASEMENTS ALONG LOT LINES ADJACENT TO STREETS, AS SHOWN HEREON, ARE HEREBY GRANTED FOR ELECTRIC, GAS, TELEPHONE, CABLE TELEVISION, FIBER OPTICS, AND POSTAL FACILITIES.
6. EIGHT-FOOT-WIDE NON-EXCLUSIVE EASEMENTS ALONG REAR LOT LINES, AS SHOWN HEREON, ARE HEREBY GRANTED FOR ELECTRIC, TELEPHONE, DRAINAGE, AND CABLE TELEVISION.
7. SIX-FOOT-WIDE NON-EXCLUSIVE EASEMENTS, AS SHOWN HEREON, ARE HEREBY GRANTED FOR ELECTRIC, GAS, TELEPHONE, CABLE TELEVISION, FIBER OPTICS, AND POSTAL FACILITIES.
8. "ACCESS AND UTILITY EASEMENTS", AS SHOWN HEREON, ARE HEREBY GRANTED FOR ELECTRIC, TELEPHONE, DRAINAGE, CABLE TELEVISION AND INGRESS/EGRESS ACCESS, SHALL BE GRANTED TO AND MAINTAINED BY THE TOWN CENTER METROPOLITAN DISTRICT, AND THE INGRESS/EGRESS ACCESS PORTION OF THE EASEMENTS SHALL ALSO BE GRANTED TO THE OWNER OF EACH LOT ABUTTING THE ACCESS AND UTILITY EASEMENTS AND THE OWNERS' RESPECTIVE HEIRS, SUCCESSORS, ASSIGNS, GRANTEEES AND MORTGAGEES, AND ALL PERSONS WHO NOW OR HEREAFTER OWN OR HOLD ANY POSSESSORY INTEREST IN EACH LOT ABUTTING THE ACCESS AND UTILITY EASEMENTS.
9. AN ACCESS EASEMENT FOR EMERGENCY SERVICES IS HEREBY GRANTED ON AND ACROSS ALL AREAS FOR POLICE, FIRE, MEDICAL, AND OTHER EMERGENCY VEHICLES AND FOR THE PROVISION OF EMERGENCY SERVICES.
10. AN ACCESS EASEMENT FOR MUNICIPAL SERVICES PROVIDED BY THE CITY AND COUNTY OF DENVER IS HEREBY GRANTED TO THE CITY AND COUNTY OF DENVER ON AND ACROSS ALL PRIVATE DRIVES.
11. TRACTS A, B, C, D, E, F, G AND H AS SHOWN HEREON ARE CONVEYED BY THIS PLAT TO THE TOWN CENTER METROPOLITAN DISTRICT FOR PUBLIC ACCESS. THESE TRACTS ARE FOR OPEN SPACE, TRAILS, LANDSCAPING, FENCES, SIDEWALKS, AND UTILITIES AND SHALL BE MAINTAINED BY THE TOWN CENTER METROPOLITAN DISTRICT.
12. UTILITY EASEMENTS ARE DEDICATED ON PRIVATE PROPERTY TO THE CITY AND COUNTY OF DENVER FOR THE BENEFIT OF THE APPLICABLE UTILITY PROVIDERS FOR THE INSTALLATION, MAINTENANCE, AND REPLACEMENT OF ELECTRIC, GAS, TELEVISION, CABLE, AND TELECOMMUNICATION FACILITIES (DRY UTILITIES). UTILITY EASEMENTS SHALL BE GRANTED WITHIN ANY ACCESS EASEMENTS AND PRIVATE STREETS IN THE SUBDIVISION. PERMANENT STRUCTURES, IMPROVEMENTS, OBJECTS, BUILDINGS, WELLS, WATER METERS AND OTHER OBJECTS THAT MAY INTERFERE WITH THE UTILITY FACILITIES OR USE THEREOF (INTERFERING OBJECTS) SHALL NOT BE PERMITTED WITHIN SAID UTILITY EASEMENTS AND THE PROVIDERS, AS GRANTEEES, MAY REMOVE ANY INTERFERING OBJECTS AT NO COST TO SUCH GRANTEEES, INCLUDING, WITHOUT LIMITATION, VEGETATION. PUBLIC SERVICE COMPANY OF COLORADO (PSCO) AND ITS SUCCESSORS RESERVE THE RIGHT TO REQUIRE ADDITIONAL EASEMENTS AND TO REQUIRE THE PROPERTY OWNER TO GRANT PSCO AN EASEMENT ON ITS STANDARD FORM.
13. BLANKET EASEMENTS FOR PUBLIC INGRESS/EGRESS, UTILITIES AND VEHICLE AND PEDESTRIAN ACCESS ARE HEREBY GRANTED ACROSS TRACTS B AND C, AS SHOWN HEREON AND CONVEYED TO THE PUBLIC.
14. SANITARY SEWER LINES LOCATED WITHIN LOTS WILL BE PRIVATELY OWNED. SANITARY SEWER LINES LOCATED IN PRIVATE ACCESS AREAS WILL BE OWNED BY THE TOWN CENTER METROPOLITAN DISTRICT.
15. THE SUBJECT PROPERTY SHOWN HEREIN LIES WITHIN OTHER AREAS - ZONE X, AREAS DETERMINED TO BE OUTSIDE THE 0.2% ANNUAL CHANCE FLOODPLAIN, AS SHOWN ON FEDERAL EMERGENCY MANAGEMENT AGENCY FLOOD INSURANCE RATE MAP INDEX NO. 0800460117H, MAP REVISED NOVEMBER 20, 2013.
16. DISTANCES ON THIS PLAT ARE GROUND DISTANCES EXPRESSED IN U.S. SURVEY FEET AND DECIMALS THEREOF. A U.S. SURVEY FOOT IS DEFINED AS EXACTLY 1200/3937 METERS.
17. ALL CURVES SHOWN ON THIS SUBDIVISION PLAT ARE TANGENT UNLESS NOTED OTHERWISE.
18. TOWER 160 SUBDIVISION FILING NO. 4 HAS 96 LOTS, 9 BLOCKS AND 8 TRACTS.
19. OWNER DECLARES AND GRANTS FOR THE BENEFIT OF THE OWNER OF EACH LOT AND THE OWNERS' RESPECTIVE HEIRS, SUCCESSORS, ASSIGNS, GRANTEEES AND MORTGAGEES, AND THEIR RESPECTIVE TENANTS, SUBTENANTS AND ALL PERSONS WHO NOW OR HEREAFTER OWN OR HOLD ANY POSSESSORY INTEREST WITHIN EACH LOT, AND THE CONCESSIONAIRES, AGENTS, EMPLOYEES, CUSTOMERS, VISITORS, CONTRACTORS, LICENSEES, LESSEES AND INVITEES OF ANY THEM, AN IRREVOCABLE, NON- EXCLUSIVE EASEMENT UPON, OVER AND ACROSS THOSE DRIVEWAYS AND ACCESSWAYS LEGALLY DESCRIBED AS TRACT H, TO WHICH ANY LOT IS CONTIGUOUS, FOR THE PURPOSE OF PROVIDING EACH OWNER OF A LOT WITH PEDESTRIAN AND VEHICULAR INGRESS, EGRESS AND ACCESS TO AND FROM A LOT AND ALL PUBLIC RIGHTS OF WAY THAT MAY BE ACCESSED FROM THE BOUNDARIES OF THE PROPERTY IN THIS SUBDIVISION NOW OR IN THE FUTURE.

## SURVEYOR'S CERTIFICATION

I, ANTHONY K. PEALL, A REGISTERED LAND SURVEYOR, REGISTERED IN THE STATE OF COLORADO DO HEREBY CERTIFY THAT THERE ARE NO ROADS, PIPELINES, IRRIGATION DITCHES, OR OTHER EASEMENTS IN EVIDENCE OR KNOWN BY ME TO EXIST ON OR ACROSS THE HEREIN BEFORE DESCRIBED PROPERTY EXCEPT AS SHOWN ON THIS PLAT. I FURTHER CERTIFY THAT I HAVE PERFORMED THE SURVEY SHOWN HEREON, OR SUCH SURVEY WAS PREPARED UNDER MY DIRECT RESPONSIBILITY AND SUPERVISION, THAT THIS PLAT ACCURATELY REPRESENTS SAID SURVEY, AND THAT ALL MONUMENTS EXIST AS SHOWN HEREON.



ANTHONY K. PEALL, LICENSED PROFESSIONAL LAND SURVEYOR  
COLORADO P.L.S. NO. 38636  
FOR AND BEHALF OF AZTEC CONSULTANTS, INC.

NOTICE: ACCORDING TO COLORADO LAW, YOU MUST COMMENCE ANY LEGAL ACTION BASED UPON ANY DEFECT IN THIS SURVEY WITHIN THREE YEARS AFTER YOU FIRST DISCOVER SUCH DEFECT IN NO EVENT, MAY ANY ACTION BASED UPON ANY DEFECT IN THIS SURVEY BE COMMENCED MORE THAN TEN YEARS FROM THE DATE OF THE CERTIFICATION SHOWN HEREON.

## ATTORNEY'S CERTIFICATION

I HEREBY CERTIFY THAT I HAVE EXAMINED THE EVIDENCE OF TITLE TO THE LAND DESCRIBED HEREON, AND FIND THE TITLE TO THE STREETS, AVENUES, TRACTS AND OTHER PUBLIC PLACES TO BE IN THE ABOVE-NAMED DEDICATOR

THIS 4th DAY OF February

A.D., 2022 AT 5:30 O'CLOCK P.M., FREE AND CLEAR OF ENCUMBRANCES EXCEPT AS SHOWN AND LISTED HEREIN.

Kristin M. Bronson  
ATTORNEY FOR THE CITY AND COUNTY OF DENVER

Mr. Pth  
ASSISTANT CITY ATTORNEY

## APPROVALS

I HEREBY CERTIFY THAT THIS MAP AND THE SURVEY REPRESENTED THEREBY ARE ACCURATE AND IN CONFORMITY WITH THE REQUIREMENTS OF CHAPTER 49, ARTICLE III OF THE REVISED MUNICIPAL CODE OF THE CITY AND COUNTY OF DENVER, AND THAT THE REQUIRED IMPROVEMENTS HAVE BEEN PROVIDED FOR.

Joe R. [Signature] 1/24/2022  
ENGINEER DATE

APPROVED BY THE EXECUTIVE DIRECTOR OF THE DEPARTMENT OF TRANSPORTATION AND INFRASTRUCTURE:

[Signature] 1/24/2022  
EXECUTIVE DIRECTOR OF THE DEPARTMENT OF TRANSPORTATION AND INFRASTRUCTURE DATE

APPROVED BY THE EXECUTIVE DIRECTOR OF COMMUNITY PLANNING AND DEVELOPMENT:

[Signature] 1.19.2022  
EXECUTIVE DIRECTOR OF COMMUNITY PLANNING AND DEVELOPMENT DATE

APPROVED BY THE EXECUTIVE DIRECTOR OF PARKS AND RECREATION:

[Signature] 2/7/22  
EXECUTIVE DIRECTOR OF PARKS AND RECREATION DATE

APPROVED BY THE COUNCIL OF THE CITY AND COUNTY OF DENVER, COLORADO

BY RESOLUTION NUMBER \_\_\_\_\_ OF SERIES 20 \_\_\_\_\_

WITNESS MY HAND AND OFFICIAL SEAL OF THE CITY AND COUNTY OF DENVER

THIS \_\_\_\_\_ DAY OF \_\_\_\_\_ A.D., 20 \_\_\_\_\_

CLERK AND RECORDER, EX-OFFICIO CLERK OF THE CITY AND COUNTY OF DENVER

BY: \_\_\_\_\_  
DEPUTY CLERK AND RECORDER

## CLERK AND RECORDER'S CERTIFICATION

STATE OF COLORADO )  
COUNTY OF \_\_\_\_\_ )SS

I HEREBY CERTIFY THAT THIS INSTRUMENT WAS FILED FOR RECORD IN MY OFFICE AT \_\_\_\_\_ O'CLOCK \_\_\_\_\_M., \_\_\_\_\_, 20\_\_\_\_ AND DULY RECORDED UNDER RECEPTION NO. \_\_\_\_\_

CLERK AND RECORDER

BY: \_\_\_\_\_ DEPUTY FEE: \_\_\_\_\_



300 East Mineral Ave., Suite 1  
Littleton, Colorado 80122  
Phone: (303) 713-1898  
Fax: (303) 713-1897

DEVELOPER  
OAKWOOD LAND DEVELOPMENT

4908 TOWER ROAD  
DENVER, CO 80249

DATE OF PREPARATION: 05-18-2020

SCALE: N/A

SHEET 1 OF 4

# TOWER 160 SUBDIVISION FILING NO. 4

A RESUBDIVISION OF A PORTION OF LOT 3, BLOCK 2, TOWER 160 SUBDIVISION FILING NO. 2  
SITUATED IN THE SOUTHEAST QUARTER OF SECTION 16, TOWNSHIP 3 SOUTH, RANGE 66 WEST OF THE SIXTH PRINCIPAL MERIDIAN,  
CITY AND COUNTY OF DENVER, STATE OF COLORADO.

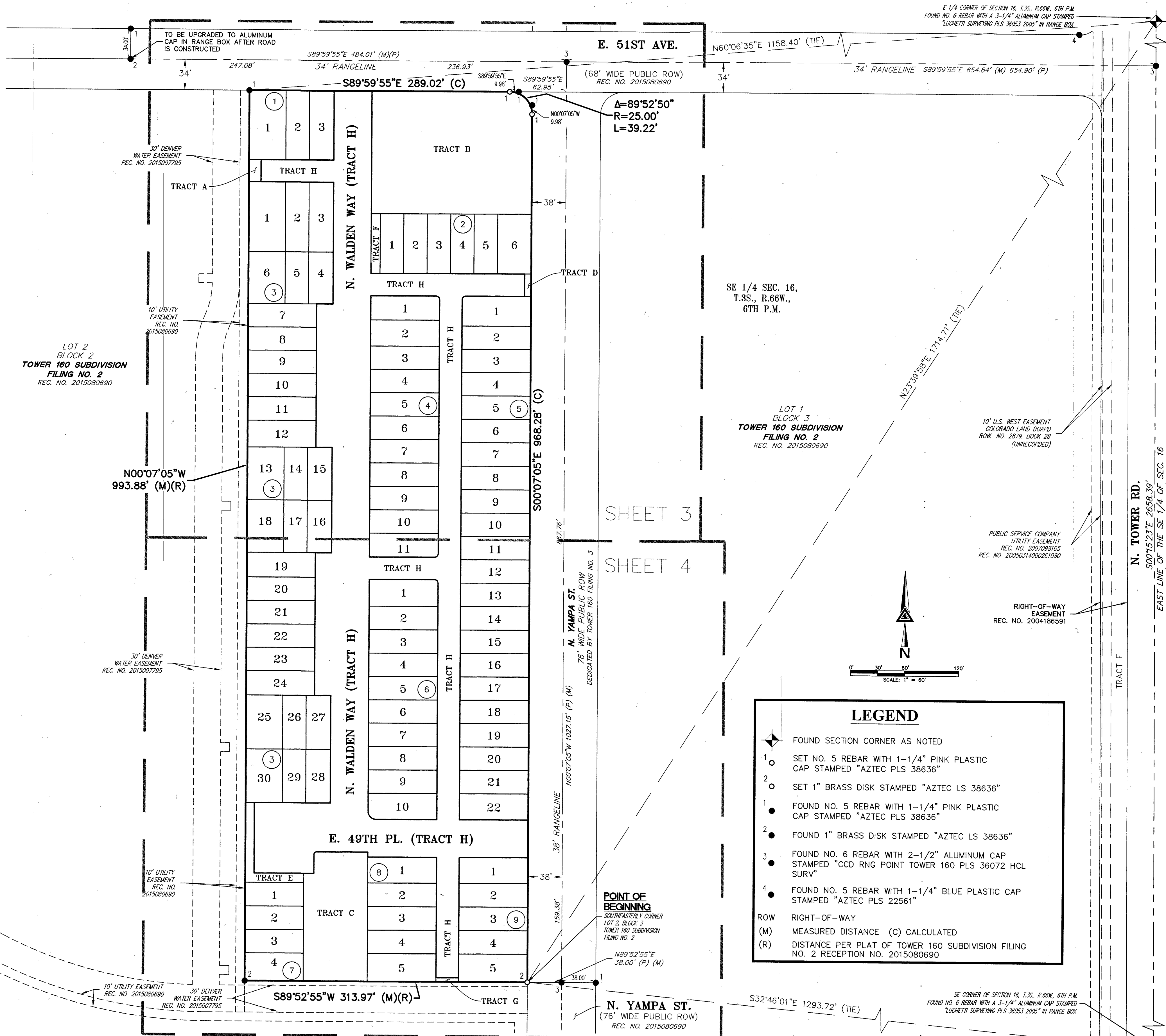

## TITLE NOTES, SCHEDULE B, PART II - EXCEPTIONS

THE EXCEPTIONS LISTED BELOW AFFECT THE SUBJECT PROPERTY, BUT ARE NOT PLOTTABLE ITEMS. THE NUMBERING REFLECTS THOSE ITEMS ACCORDING TO THE TITLE COMMITMENT REFERENCED IN NOTE 1 ON SHEET 1 OF 4. (SKIPPED NUMBERS WERE "INTENTIONALLY DELETED" BY THE TITLE COMPANY, ARE PLOTTABLE AND SHOWN HEREON, OR DO NOT AFFECT THE SUBJECT PROPERTY)

NOTE: THE WORD "AFFECT" AS USED ABOVE, IS HEREBY DEFINED AS: "A DETERMINATION THAT THE PROPERTY OR INTERESTS DESCRIBED, WITHIN THE ITEMS LISTED AMONG THE SCHEDULE B - SECTION 2 PROVIDED, FALLS WITHIN OR TOUCHES THE SURVEYED PROPERTY"

9. NOTICE OF DISSOLUTION AND ANNEXATION OF SCHOOL DISTRICTS BY COUNTY SCHOOL PLANNING COMMITTEE RECORDED NOVEMBER 29, 1968 IN BOOK 1479 AT PAGE 199 (ADAMS COUNTY RECORDS).
11. AMENDED ORDER AND DECREE IN THE MATTER OF THE ORGANIZATION OF THE SABLE-ALTURA FIRE PROTECTION DISTRICT RECORDED OCTOBER 3, 1972 IN BOOK 1821 AT RECEPTION NO. 975694 (ADAMS COUNTY RECORDS).
13. ORDER AND STIPULATION RECORDED JULY 29, 1980 IN BOOK 2477 AT PAGE 159 (ADAMS COUNTY RECORDS AND RECORDED AUGUST 31, 1981 IN BOOK 2432 AT PAGE 361 (DENVER COUNTY RECORDS).
14. ORDER AND DECREE CREATING DISTRICT, THE FIRST CREEK METROPOLITAN DISTRICT RECORDED FEBRUARY 24, 1984 IN BOOK 2843 AT PAGE 721 (ADAMS COUNTY RECORDS).
15. COLORADO STATE BOARD OF LAND COMMISSIONERS LEASE OF STATE LAND RECORDED FEBRUARY 7, 1985 IN BOOK 2965 AT PAGE 480 AND IN BOOK 2965 AT PAGE 514 (ADAMS COUNTY RECORDS).  
NOTE: AMENDMENT TO LEASE RECORDED FEBRUARY 7, 1985 IN BOOK 2965 AT PAGE 548 (ADAMS COUNTY RECORDS).
16. ANNEXATION PLAT I RECORDED MAY 26, 1988 AT RECEPTION NO. R-88-0270668 (DENVER COUNTY RECORDS AND RECORDED MAY 26, 1988 IN BOOK 3450 AT PAGE 751 (ADAMS COUNTY RECORDS) AND RECORDED JANUARY 16, 1990 IN BOOK 3639 AT PAGE 318 (ADAMS COUNTY RECORDS).
17. ORDINANCE NO. 453, SERIES OF 1988 RECORDED OCTOBER 23, 2002 AT RECEPTION NO. 2002199305.
27. RESERVATIONS OF ALL RIGHTS TO ANY AND ALL SUB-SURFACE PORE SPACE, MINERALS, ORES AND METALS OF ANY KIND AND CHARACTER, ALL ALL COAL, ASPHALTUM, OIL, GAS AND OTHER LIKE SUBSTANCES AND ALL GEOTHERMAL RESOURCES IN, ON OR UNDER THE LAND, AND RIGHTS OF INGRESS AND EGRESS IN, ON, UNDER, OVER, ACROSS AND THROUGH SUBJECT PROPERTY FOR THE PURPOSE OF EXPLORATION, PRODUCTION, MINING, EXTRACTION, REMOVAL OF OR ACCESS TO SUCH SUBSTANCES AND RESOURCES, TOGETHER WITH ENOUGH OF THE SURFACE AS MAY BE NECESSARY FOR THE PROPER AND CONVENIENT WORKING OF SUCH SUBSTANCES AND RESOURCES AND THE RIGHT TO CROSS GRANTEE'S LAND ADJOINING TO ACCESS THE MINERAL ESTATE RECORDED, AS RESERVED IN IN PATENT FROM THE STATE OF COLORADO, ACTING BY AND THROUGH THE STATE BOARD OF LAND COMMISSIONERS RECORDED MARCH 26, 2019 AT RECEPTION NO. 2019032987.
28. NO SURFACE OCCUPANCY AGREEMENT, LEASE NO. 112484 RECORDED MARCH 26, 2019 AT RECEPTION NO. 2019032988.
29. AGREEMENT RECORDED MARCH 26, 2019 AT RECEPTION NO. 2019032989.
34. AGREEMENT TO PROVIDE PARKS DEDICATION RECORDED DECEMBER 13, 2021 AT RECEPTION NO. 2021226923.
35. SUPPLEMENT TO AFFORDABLE HOUSING PLAN (AHP) RECORDED DECEMBER 13, 2021 AT RECEPTION NO. 2021226924.

| TRACT SUMMARY TABLE |                |              |                                    |          |               |
|---------------------|----------------|--------------|------------------------------------|----------|---------------|
| TRACT               | AREA (SQ.FT)   | AREA (AC ±)  | USE                                | OWNED BY | MAINTAINED BY |
| TRACT A             | 334            | 0.008        | OPEN SPACE/UTILITY/DRAINAGE/ACCESS | TCMD     | TCMD          |
| TRACT B             | 24,320         | 0.558        | OPEN SPACE/UTILITY/DRAINAGE/ACCESS | TCMD     | TCMD          |
| TRACT C             | 9,947          | 0.228        | OPEN SPACE/UTILITY/DRAINAGE/ACCESS | TCMD     | TCMD          |
| TRACT D             | 180            | 0.004        | OPEN SPACE/UTILITY/DRAINAGE/ACCESS | TCMD     | TCMD          |
| TRACT E             | 1,431          | 0.033        | OPEN SPACE/UTILITY/DRAINAGE/ACCESS | TCMD     | TCMD          |
| TRACT F             | 670            | 0.015        | OPEN SPACE/UTILITY/DRAINAGE/ACCESS | TCMD     | TCMD          |
| TRACT G             | 114            | 0.003        | OPEN SPACE/UTILITY/DRAINAGE/ACCESS | TCMD     | TCMD          |
| TRACT H             | 81,244         | 1.865        | ROW/UTILITY/DRAINAGE/ACCESS        | TCMD     | TCMD          |
| <b>TOTAL</b>        | <b>118,240</b> | <b>2.714</b> |                                    |          |               |

TCMD = TOWN CENTER METROPOLITAN DISTRICT  
ROW = RIGHT-OF-WAY

| LAND SUMMARY CHART    |                |              |                 |
|-----------------------|----------------|--------------|-----------------|
| TYPE                  | AREA (SF)      | AREA (AC)    | % OF TOTAL AREA |
| RESIDENTIAL LOTS (96) | 193,572        | 4.444        | 62%             |
| TRACTS (8)            | 118,240        | 2.714        | 38%             |
| <b>TOTALS</b>         | <b>311,812</b> | <b>7.158</b> | <b>100%</b>     |



FOR AND ON BEHALF OF  
AZTEC CONSULTANTS, INC.

|  |   |   |                                 |
|--|---|---|---------------------------------|
|  | 300 East Mineral Ave., Suite 1<br>Littleton, Colorado 80122<br>Phone: (303) 713-1898<br>Fax: (303) 713-1897 | <b>DEVELOPER</b><br>OAKWOOD LAND DEVELOPMENT          | DATE OF PREPARATION: 05-18-2020 |
|  | Aztec Proj. No. 19320-20<br>Drawn By: BAM   | 4908 TOWER ROAD<br>DENVER, CO 80249<br>(303) 688-6868 | SCALE: 1" = 60'<br>SHEET 2 OF 4 |

# TOWER 160 SUBDIVISION FILING NO. 4

A RESUBDIVISION OF A PORTION OF LOT 3, BLOCK 2, TOWER 160 SUBDIVISION FILING NO. 2  
SITUATED IN THE SOUTHEAST QUARTER OF SECTION 16, TOWNSHIP 3 SOUTH, RANGE 66 WEST OF THE SIXTH PRINCIPAL MERIDIAN,  
CITY AND COUNTY OF DENVER, STATE OF COLORADO.

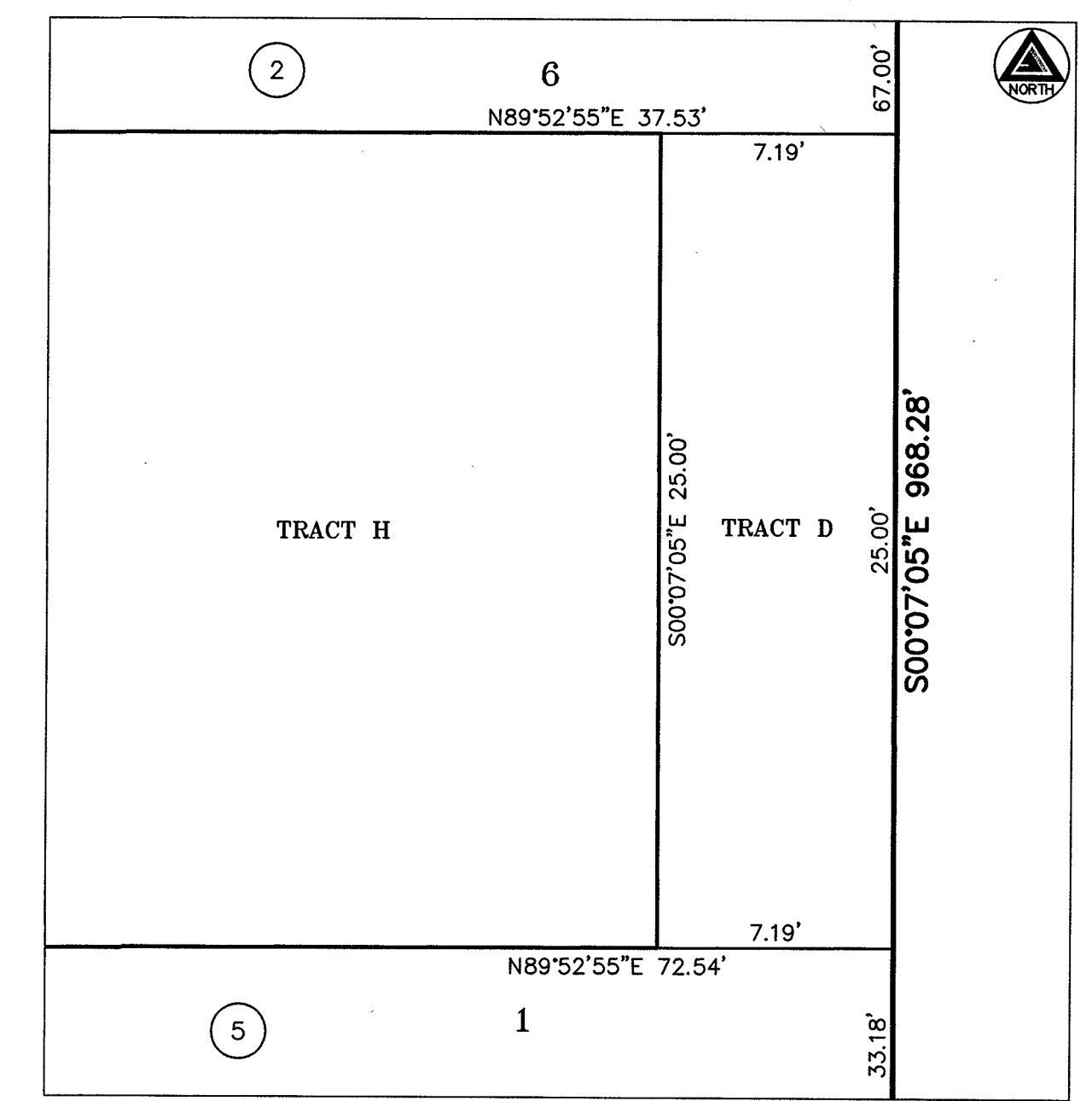
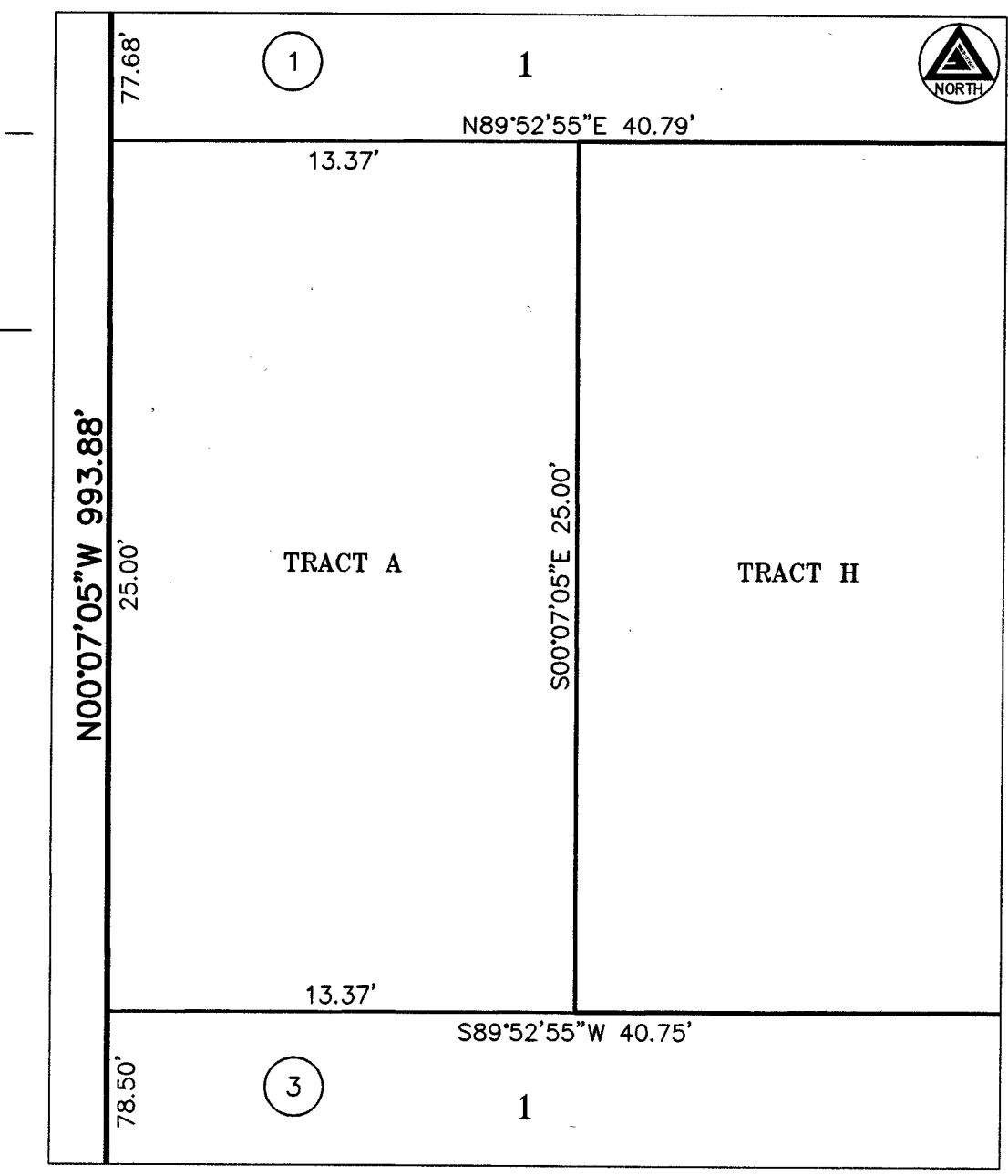
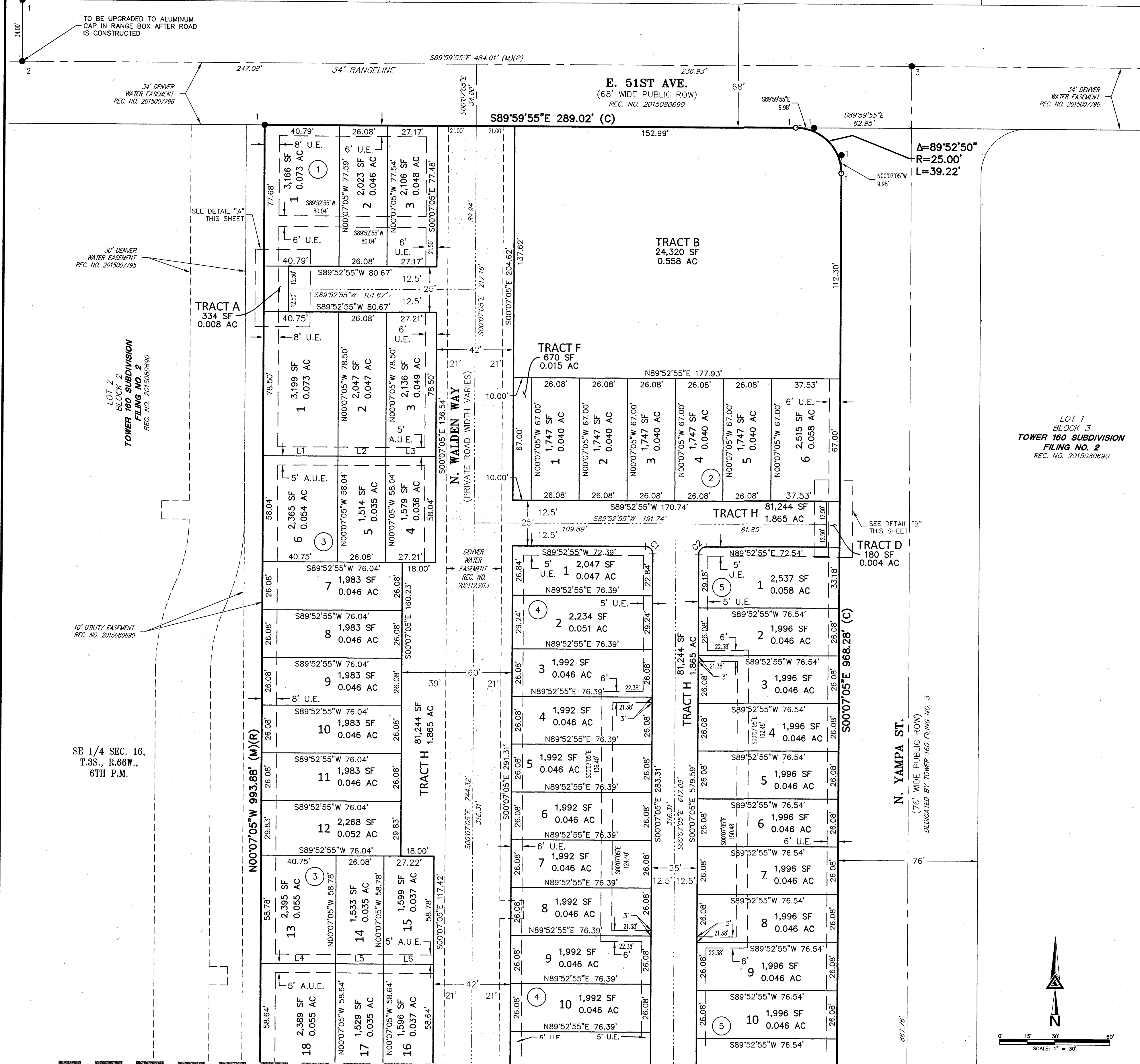

**LINE TABLE**

| LINE | BEARING     | LENGTH |
|------|-------------|--------|
| L1   | N89°52'55"E | 40.75' |
| L2   | N89°52'55"E | 26.08' |
| L3   | N89°52'55"E | 27.21' |
| L4   | S89°52'55"W | 40.75' |
| L5   | S89°52'55"W | 26.08' |
| L6   | S89°52'55"W | 27.21' |

**CURVE TABLE**

| CURVE | DELTA     | RADIUS | LENGTH |
|-------|-----------|--------|--------|
| C1    | 90°00'00" | 4.00'  | 6.28'  |
| C2    | 90°00'00" | 4.00'  | 6.28'  |

**LEGEND**

- SET NO. 5 REBAR WITH 1-1/4" PINK PLASTIC CAP STAMPED "AZTEC PLS 38636"
- FOUND NO. 5 REBAR WITH 1-1/4" PINK PLASTIC CAP STAMPED "AZTEC PLS 38636"
- U.E. UTILITY EASEMENT
- A.U.E. ACCESS AND UTILITY EASEMENT
- ROW RIGHT-OF-WAY
- (M) MEASURED DISTANCE (C) CALCULATED
- (R) DISTANCE PER PLAT OF TOWER 160 SUBDIVISION FILING NO. 2 RECEPTION NO. 2015080690
- DENVER WATER EASEMENT RECEPTION NO. 2021123813
- DENVER WATER EASEMENT RECEPTION NO. 2021123814
- DENVER WATER EASEMENT RECEPTION NO. 2021123815
- BOUNDARY LINE
- RIGHT-OF-WAY LINE
- EXISTING EASEMENT
- LOT OR TRACT LINE
- PROPOSED EASEMENT
- PRIVATE STREET

SE 1/4 SEC. 16,  
T.3S., R.66W.,  
6TH P.M.

SEE SHEET 4

MATCHLINE

SEE SHEET 4

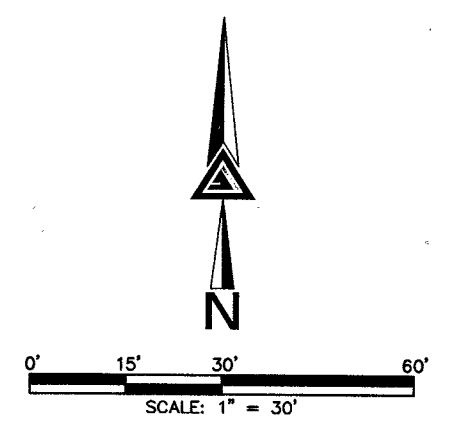

**AZTEC**  
CONSULTANTS, INC.

300 East Mineral Ave., Suite 1  
Littleton, Colorado 80122  
Phone: (303) 713-1898  
Fax: (303) 713-1897  
www.aztec-land.com

AzTec Proj. No. 19320-20 Drawn By: BAM

**DEVELOPER**  
OAKWOOD LAND DEVELOPMENT

4908 TOWER ROAD  
DENVER, CO 80249  
(303) 688-6868

DATE OF PREPARATION: 05-18-2020

SCALE: T = 30'

SHEET 3 OF 4



FOR AND ON BEHALF OF  
AZTEC CONSULTANTS, INC.

# TOWER 160 SUBDIVISION FILING NO. 4

A RESUBDIVISION OF A PORTION OF LOT 3, BLOCK 2, TOWER 160 SUBDIVISION FILING NO. 2  
SITUATED IN THE SOUTHEAST QUARTER OF SECTION 16, TOWNSHIP 3 SOUTH, RANGE 66 WEST OF THE SIXTH PRINCIPAL MERIDIAN,  
CITY AND COUNTY OF DENVER, STATE OF COLORADO.

SEE SHEET 3

MATCHLINE

SEE SHEET 3

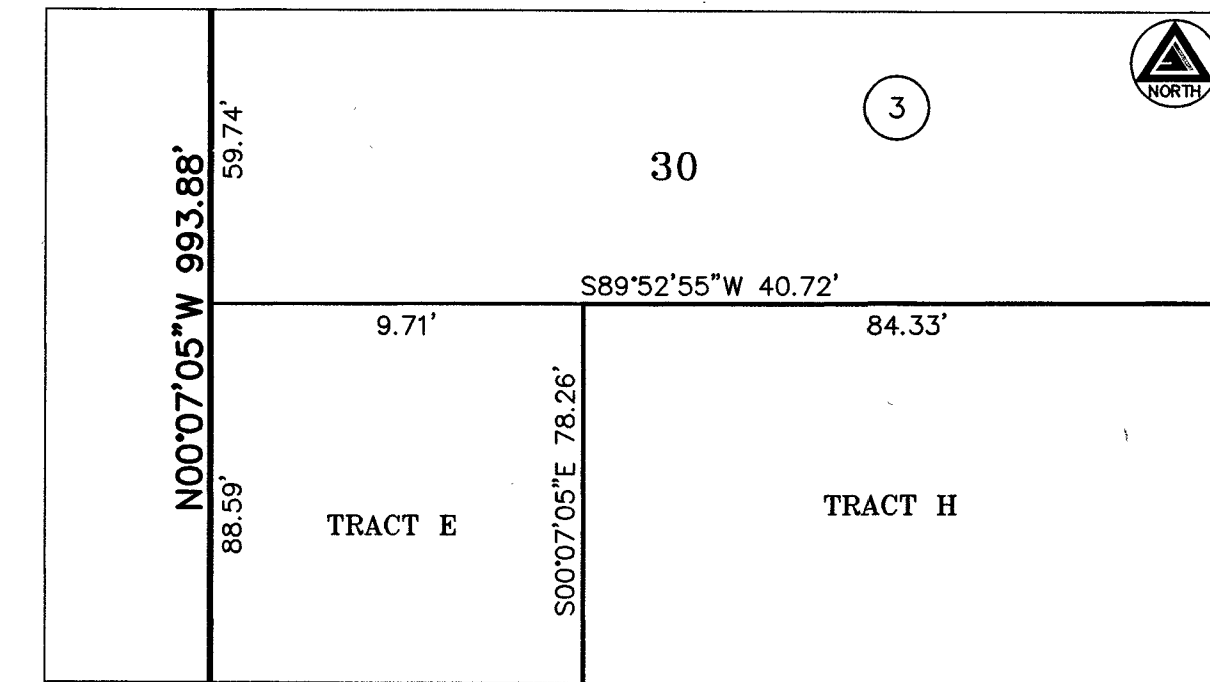
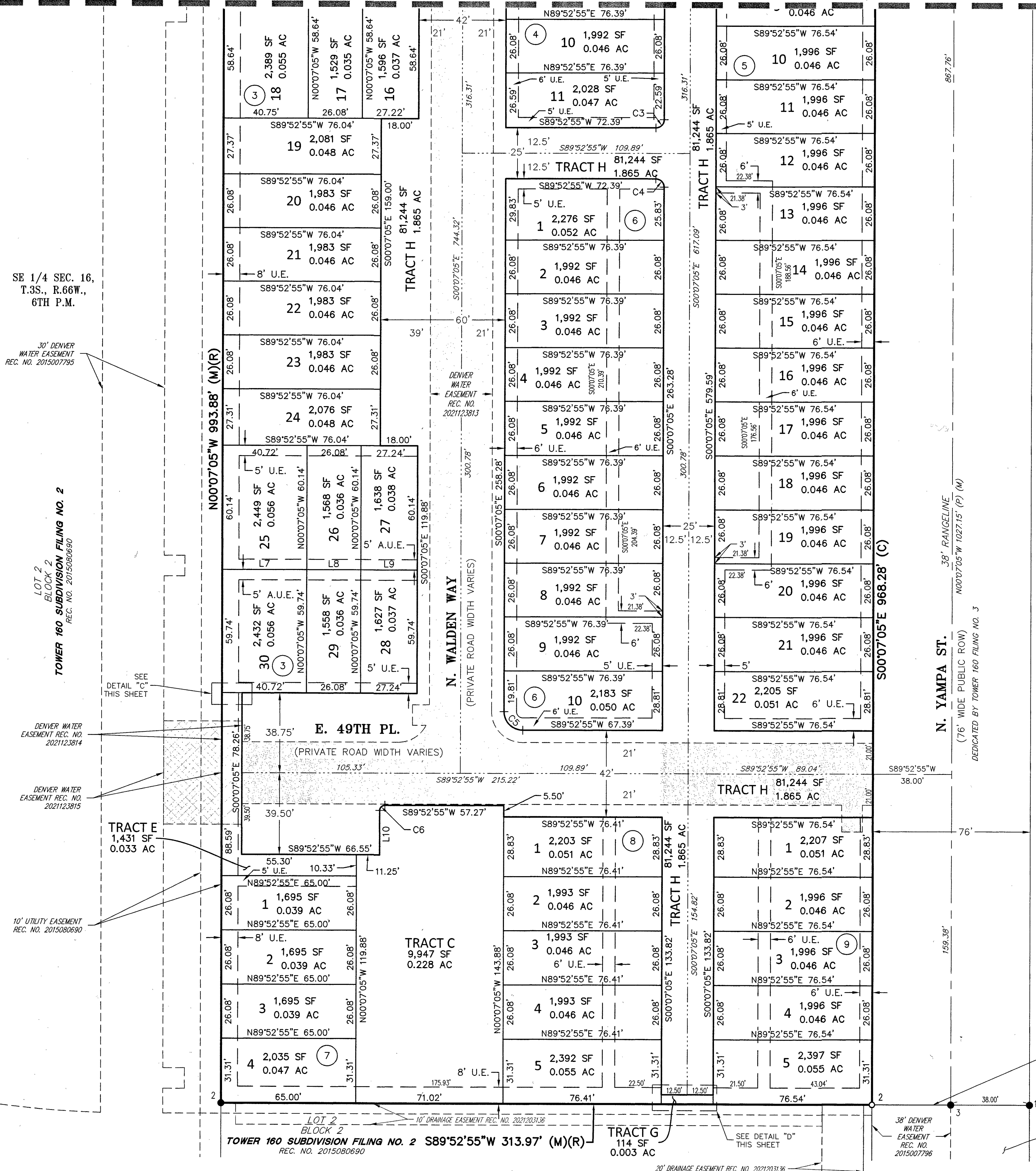

DETAIL "C"  
SCALE: 1" = 5'

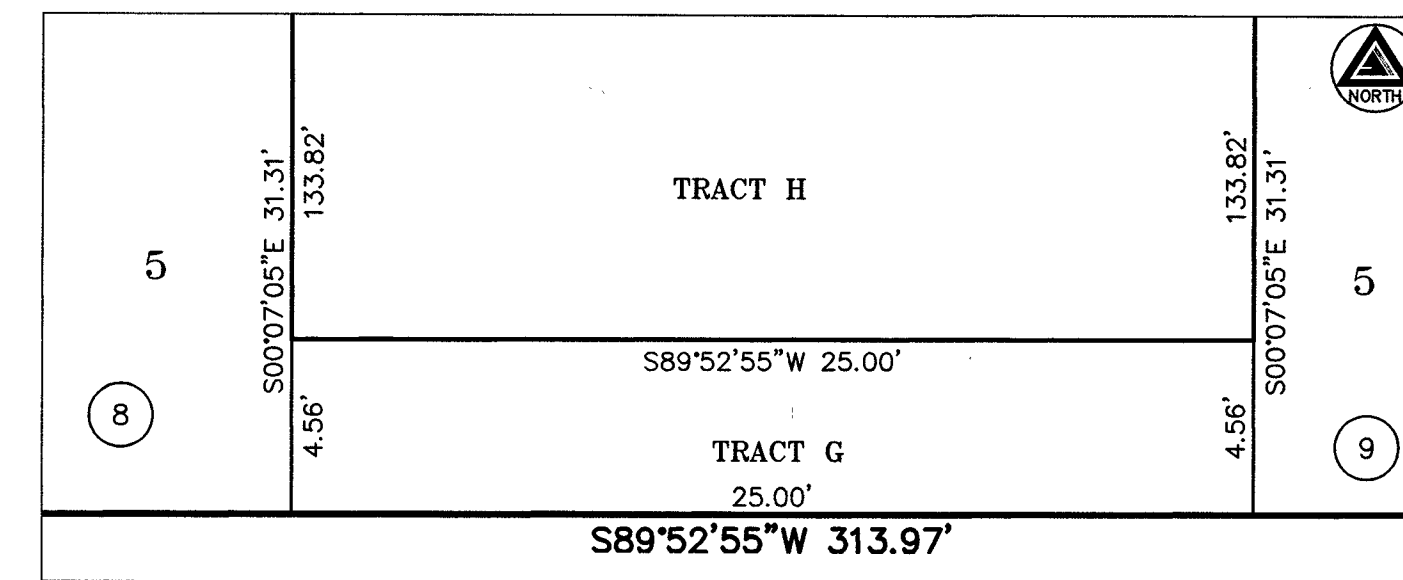

DETAIL "D"  
SCALE: 1" = 5'

**LEGEND**

- 2 ○ SET 1" BRASS DISK STAMPED "AZTEC LS 38636"
- FOUND 1" BRASS DISK STAMPED "AZTEC LS 38636"
- U.E. UTILITY EASEMENT
- A.U.E. ACCESS AND UTILITY EASEMENT
- ROW RIGHT-OF-WAY
- (M) MEASURED DISTANCE (C) CALCULATED
- (R) DISTANCE PER PLAT OF TOWER 160 SUBDIVISION FILING NO. 2 RECEPTION NO. 2015080690
- DENVER WATER EASEMENT RECEPTION NO. 2021123813
- DENVER WATER EASEMENT RECEPTION NO. 2021123814
- DENVER WATER EASEMENT RECEPTION NO. 2021123815
- BOUNDARY LINE — LOT OR TRACT LINE
- RIGHT-OF-WAY LINE — PROPOSED EASEMENT
- - - EXISTING EASEMENT - - - PRIVATE STREET

| LINE TABLE |             |        | CURVE TABLE |           |        |        |
|------------|-------------|--------|-------------|-----------|--------|--------|
| LINE       | BEARING     | LENGTH | CURVE       | DELTA     | RADIUS | LENGTH |
| L7         | S89°52'55"W | 40.72' | C3          | 90°00'00" | 4.00'  | 6.28'  |
| L8         | S89°52'55"W | 26.08' | C4          | 90°00'00" | 4.00'  | 6.28'  |
| L9         | S89°52'55"W | 27.24' | C5          | 90°00'00" | 9.00'  | 14.14' |
| L10        | S00°07'05"E | 21.50' | C6          | 90°00'00" | 2.50'  | 3.93'  |

**AZTEC**  
CONSULTANTS, INC.

DEVELOPER  
**OAKWOOD LAND DEVELOPMENT**

DATE OF PREPARATION: 05-18-2020

SCALE: 1" = 30'

SHEET 4 OF 4

Aztec Proj. No.: 19320-20

Drawn By: BAM

4908 TOWER ROAD  
DENVER, CO 80249  
(303) 688-6868

FOR AND ON BEHALF OF  
AZTEC CONSULTANTS, INC.

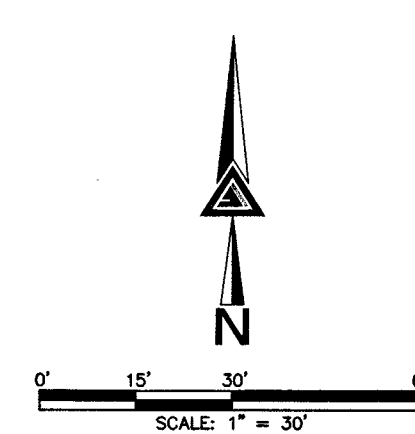
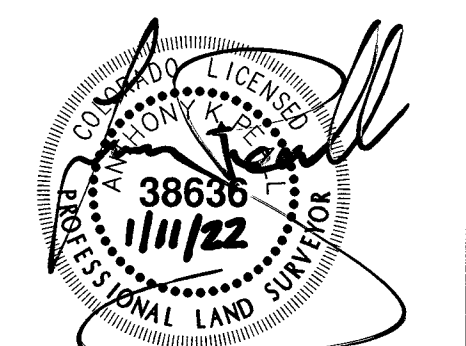

LOT 1  
BLOCK 3  
TOWER 160 SUBDIVISION  
FILING NO. 2  
REC. NO. 2015080690

N. YAMPA ST.  
(76' WIDE PUBLIC ROW)  
REC. NO. 2015080690