



APPLICATION SUBMITTAL CHECKLIST

FOR CITY & COUNTY OF DENVER EASEMENT RELINQUISHMENT

Any Easement Relinquishment Application submittal not meeting all minimum checklist criteria herein shall be rejected as incomplete. Download and fill-out this checklist and submit along with the Application and supporting documentation to DOTI.ER@denvergov.org.

1. Easement Relinquishment Application

- Easement Relinquishment Application completed and signed by property owner or a vested party

2. Copy of Easements to be Relinquished

- Original holding document(s) of easement(s) to be relinquished, e.g. Ordinance, PNEE, Subdivision plat, etc.
- Clerk and Recorder's Book and Page and/or Recordation Number(s)

3. Land Descriptions *(select one)*

- Not applicable for Easements relinquished in their entirety
- Land description(s) prepared by a Professional Land Surveyor licensed in the State of Colorado for the portion of easement to be relinquished prepared in accordance with [DOTI Survey Land Description Requirements](#)
 - PDF format stamped and signed by Professional Land Surveyor
 - Text only in Microsoft Word format

4. Site Plan

ACCURATELY, LABELED ENGINEERED DRAWINGS TO INCLUDE THE FOLLOWING:

- Numerical and Bar Scale (scale no smaller than 1:40)
- North Arrow
- Legend
- Plan date and revision number, if applicable
- Easement in its entirety
- Portion of easement to be relinquished
- Newly proposed easements to be granted, if applicable
- Property lines,
- Right-of-way lines
- Label property addresses and street names
- Existing improvements within easement
- Proposed improvements in easement relinquishment area
- All existing, abandoned, and relocated utilities
- Aerial imagery can be used, but does not replace the required accurately engineered drawings

5. Fees

EASEMENT RELINQUISHMENT FEES MUST BE PAID IMMEDIATELY AFTER ER PROVIDES AN INVOICE

- Initial Processing Fee = \$1,000.00 (non-refundable)
- Survey Land Description Review Fee = \$500 (non-refundable)
- Ordinance Fee = \$300 (non-refundable)

Property Owner or Authorized Application Representative:

By signing below, I certify that all above information has been incorporated in our application submittal.

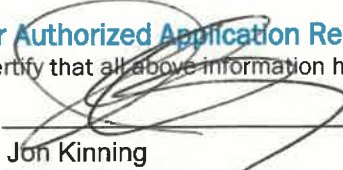
SIGNATURE:  DATE: 11/15/2025
PRINT NAME: Jon Kinning PHONE: 303-785-6900
EMAIL: jon.kinning@rkindustries.com COMPANY: KH Georgia LLC, et al

City and County of Denver Department of Transportation & Infrastructure
Right of Way Services | Engineering & Regulatory
201 W. Colfax Ave, Dept. 507 | Denver, CO 80202
www.denvergov.org/ROWPlanReview
DOTI.ER@denvergov.org
(720) 865-3003



APPLICATION

FOR CITY & COUNTY OF DENVER EASEMENT RELINQUISHMENT

To apply for an Ordinance to Relinquish an Easement held by the City and County of Denver, complete this application and submit together with the Submittal Checklist and required application materials in accordance with the [Easement Relinquishment Application Requirements](#) to DOTI.ER@denvergov.org. Please type or print clearly. If necessary, attach additional sheets to fully answer any of the following sections. Incomplete applications packages will not be accepted. Questions on this application or this process can be sent to DOTI.ER@denvergov.org.

PROPERTY OWNER:

Company Name: KH Georgia LLC, et al

Contact Name: Jon Kinning

Property Address: 3800 N Xanthia Street

Billing Address: 3800 N Xanthia Street

Phone: 303-785-6900 Email: jon.kinning@rkindustries.com

PRIMARY CONTACT: Check if the same as Adjacent Property Owner

Company Name: Kimley-Horn and Associates, Inc.

Contact Name: Eric McDaniel, PE

Address: 1125 17th Street, Suite 1400, Denver, CO 80202

Phone: 720-943-5657 Email: eric.mcdaniel@kimley-horn.com

PROJECT INFORMATION:

Project Name: Xanthia Multi-Family

Address of Property Containing Easement: 3800 N Xanthia Street

Is this project associated with a LAND DEVELOPMENT REVIEW?

Yes No If 'Yes', provide Project Master, Concept or Site Development Plan Project Numbers:

2022-PROJMSTR-0000336; 2024-SDP-0000029

REASON FOR EASEMENT RELINQUISHMENT:

Describe why you are requesting this relinquishment and why the easement(s) are no longer needed.

The existing 18" PVC private sanitary main and easement serviced the area prior to the Stapleton Filing No. 18 redevelopment. During the redevelopment the sanitary mains were realigned and flows no longer enter the Site through this stretch of sanitary main and it now only serves the flows from the onsite RK Mechanical structure. Therefore, the sanitary sewer easement is no longer needed and can be relinquished to support the Xanthia Multi-Family development.

City and County of Denver Department of Transportation & Infrastructure
 Right of Way Services | Engineering & Regulatory
 201 W. Colfax Ave, Dept. 507 | Denver, CO 80202
www.denvergov.org/ROWPlanReview
DOTI.ER@denvergov.org
 (720) 865-3003

CONNECT WITH US | 311 | DENVERGOV.ORG | DENVER 8 TV



EASEMENT RELINQUISHMENT INFORMATION: Quantity of easements to be relinquished: 1

List all easements to be relinquished:

| No. | <i>Original holding document that reserves or grants the easement:</i> | | <i>Portion of the easement to be relinquished:</i> | |
|-----|--|-----------------------------------|--|--|
| | Clerk & Recorder Recordation No(s). | Ordinance No(s). if applicable | Relinquish in its Entirety: | Partially relinquish as described in attached land description(s): |
| 1 | 9900004241 | | <input type="checkbox"/> | <input checked="" type="checkbox"/> |
| 2 | | | <input type="checkbox"/> | <input type="checkbox"/> |
| 3 | | | <input type="checkbox"/> | <input type="checkbox"/> |
| 4 | | | <input type="checkbox"/> | <input type="checkbox"/> |
| 5 | | | <input type="checkbox"/> | <input type="checkbox"/> |

Describe the status of the Easement(s):

In the space below, describe each easement status. Include why the easement was originally granted and any additional relevant information

The existing 18" PVC private sanitary main and easement serviced the area prior to the Stapleton Filing No. 18 redevelopment. During the redevelopment the sanitary mains were realigned and flows no longer enter the Site through this stretch of sanitary main and it now only serves the flows from the onsite RK Mechanical structure. Therefore, the sanitary sewer easement is no longer needed and can be relinquished

Are there utilities in the Easement(s)? Yes No

If yes, list each utility and identify utility owner, utility type, and size (e.g. CCD 8-inch Sanitary Sewer); whether it will be removed, relocated, or abandoned in-place; and, expected schedule.

An existing 18" PVC private sanitary sewer main is located within this easement. The sanitary main will ultimately be removed as part of the Xanthia Multi-Family development.

APPLICANT SIGNATURE:

By signing below, I certify that I am the owner or vested party of the real property that is the subject of this Easement Relinquishment application and the information contained herein is accurate and complete:

SIGNATURE: DATE: 1/15/2025
 PRINT NAME: Jon Kinning PHONE: 303-785-6900
 EMAIL: jon.kinning@rkindustries.com COMPANY: KH Georgia LLC, et al

City and County of Denver Department of Transportation & Infrastructure
 Right of Way Services | Engineering & Regulatory
 201 W. Colfax Ave, Dept. 507 | Denver, CO 80202
www.denvergov.org/ROWPlanReview
DOTI.ER@denvergov.org
 (720) 865-3003

72.41
1-8

PROPERTY DEED
(Statutory Bargain and Sale)
(RK-I)

THE CITY AND COUNTY OF DENVER, for and on behalf of its Department of Aviation, a Colorado municipal corporation ("City"), whose address is 8500 Peña Boulevard, Denver, Colorado, 80249, for the consideration of Seven Hundred Twenty Six Thousand Nine Hundred Fifteen Dollars (\$726,915.00) in hand paid, hereby sells and conveys to STAPLETON DEVELOPMENT CORPORATION, a Colorado non-profit corporation ("Grantee"), whose address is 3090 Syracuse Street, Denver, Colorado 80207, the following real property in the City and County of Denver, State of Colorado, to-wit:

SEE EXHIBIT 1 ATTACHED HERETO AND
INCORPORATED HEREIN BY THIS REFERENCE

(hereinafter the "Property"), together with all improvements located therein as of the date hereof and together with all its appurtenances.

The City hereby reserves for itself, its successors and assigns, any and all water and water rights the City may own with respect to the Property.

The City hereby reserves to itself and its successors and assigns an exclusive and perpetual easement for locating, establishing and constructing drainage facilities for, water and sewage across the real property described in Exhibit 2 attached hereto and incorporated herein by this reference ("Sewer Easement Property"). The City hereby reserves the right to enter, re-enter and use the herein described reserved Drainage Easement Property to locate, construct, inspect, operate, maintain, repair, remove, replace, relocate and reconstruct drainage facilities for water, and sewage including underground and surface facilities and appurtenances thereto, into, within, over, upon, across, through and under the Sewer Easement Property. Grantee shall not erect or place any building, tree or other obstruction on the Sewer Easement Property and the City shall have the right to remove such building, tree or other obstruction without liability. City shall also have the right from time to time to trim and cut down and clear away any and all trees and brush now or hereafter on the Sewer Easement Property which now or hereafter in the opinion of the City may be a hazard to City's drainage facilities or appurtenances thereto or may interfere with the exercise of City's rights hereunder.

In addition, the City hereby reserves to itself and its successors and assigns a non-exclusive easement for access, ingress and egress for emergency vehicles and for the purpose of City vehicular access or for the public safety, across, over, and within the real property described on Exhibit 3. The City shall not be obligated or expected to perform any construction, reconstruction, maintenance, repair, cleaning, snow removal, lighting or traffic control on such easement property.

The City hereby submits the Property to a Restrictive Use Covenant effective from and after the date hereof. By accepting this deed, Grantee specifically covenants and agrees on behalf of itself and its successors, transferees and assigns that the Property or any part thereof or any interest therein shall not be used for aircraft operation or aircraft flight operations and that all runways and taxiways shall remain



EXHIBIT 1
Property Deed RK-I

SHEET 1 OF 2

R K Mechanical Parcel

LEGAL DESCRIPTION

A parcel of land located in the Northwest Quarter of Section 27 and the Northeast Quarter of Section 28, Township 3 South, Range 67 West, 6th Principal Meridian, City and County of Denver, State of Colorado, being more particularly described as follows:

Commencing at the Northeast corner of said Section 28; thence S 00°28'31" E along the East line of said Northeast Quarter, a distance of 384.93 feet to the point of beginning; thence along the following eight (8) courses:

1. S 72°03'56" E, a distance of 108.94 feet;
2. S 02°45'12" W, a distance of 588.83 feet;
3. S 89°40'09" W, a distance of 599.17 feet;
4. N 00°07'54" W, a distance of 727.62 feet
5. N 89°43'07" E, a distance of 77.50 feet;
6. N 00°00'00" E, a distance of 114.83 feet;
7. S 62°39'49" E, a distance of 423.32 feet;
8. S 72°03'56" E, a distance of 75.51 feet to the point of beginning'

Said parcel contains 435,597 square feet or 10.000 acres more or less.

Basis of Bearings: The East line of the Northeast Quarter of Section 28 was found to be S 00°28' 31" E, based upon the North American Datum of 1983, Colorado Central Zone, a local network as established by CDOT, District 6, Reference stations "King" and "Ramp".

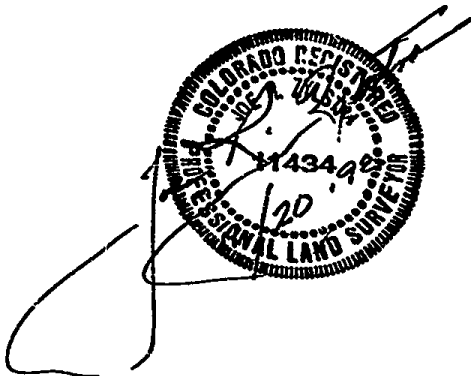

ZYLSTRA BAKER SURVEYING, INC.
1510 WEST TUFTS AVENUE
ENGLEWOOD, COLORADO 80110
(303) 781 0700

EXHIBIT 1 Property Deed RK-I Sheet 2

NW 1/4 SEC. 27 & NE 1/4 SEC. 28
T. 3 S., R. 67 W., 6TH PRINCIPAL MERIDIAN
CITY AND COUNTY OF DENVER, COLORADO

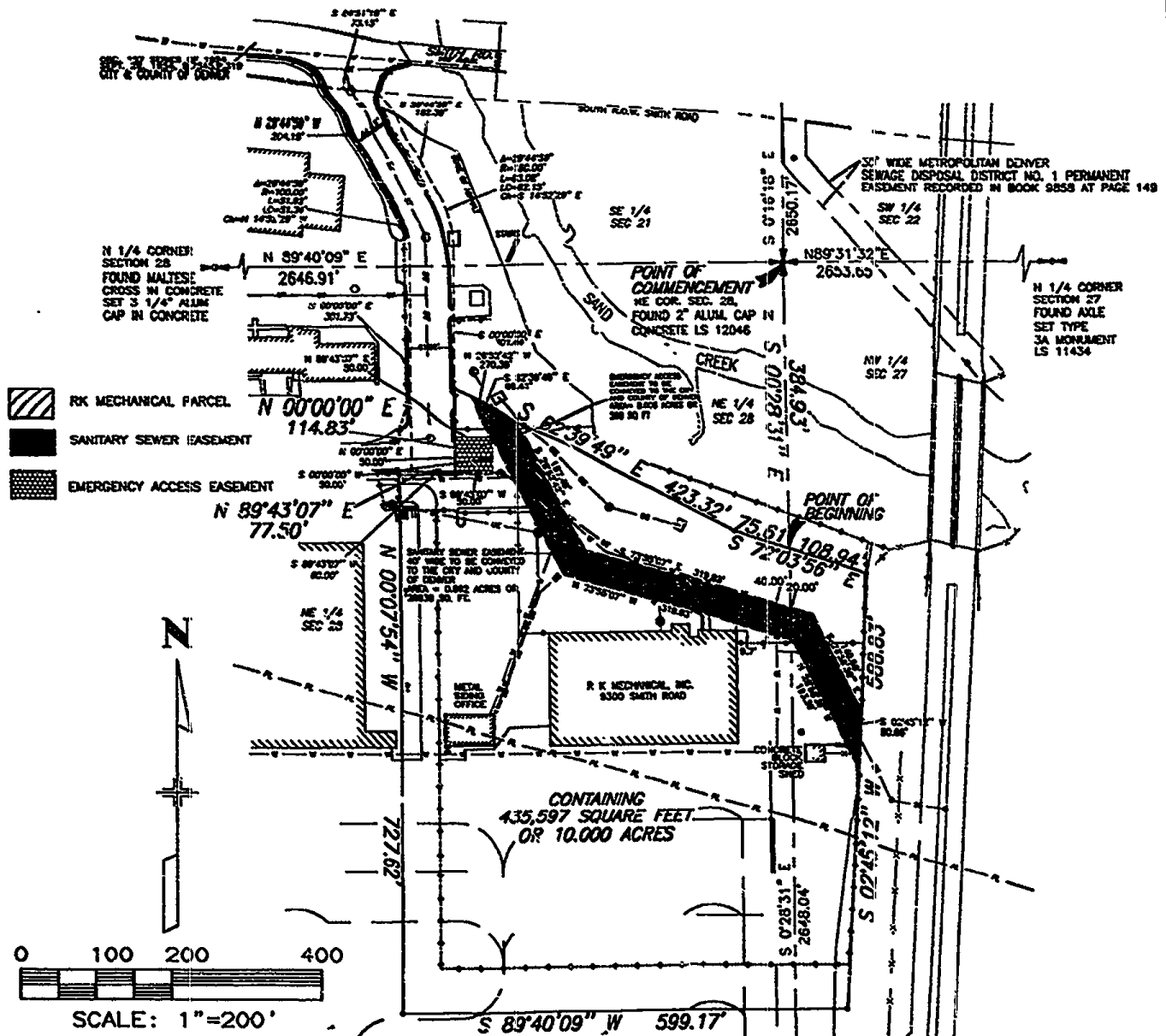

- RK MECHANICAL PARCEL
- SANITARY SEWER EASEMENT
- EMERGENCY ACCESS EASEMENT

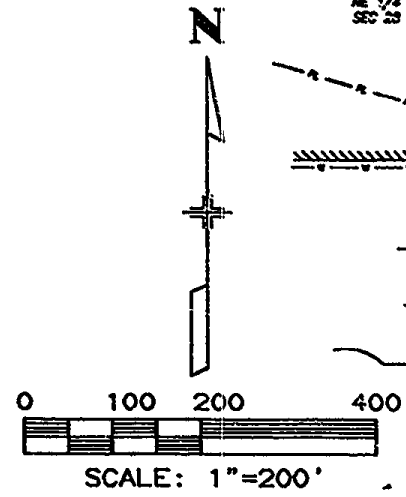

| AREA TABULATION | | |
|---------------------------|----------------------|--------------------|
| RK MECHANICAL PARCEL | 435,597 SQ FT | 10.000 ACRES |
| SANITARY SEWER EASEMENT | 28,838 SQ FT | 0.662 ACRES |
| EMERGENCY ACCESS EASEMENT | 250 SQ FT | 0.006 ACRES |
| NET RK MECHANICAL | 407,009 SQ FT | 9.344 ACRES |

| | | | |
|--|------------|----------------|--|
| ZYLSTRA BAKER SURVEYING INC. 1510 WEST TUFTS AVENUE ENGLEWOOD, CO 80110 PHONE (303) 781-0700 | | | |
| CITY AND COUNTY OF DENVER | | | |
| R K MECHANICAL PARCEL | | | |
| SCALE: 1"=200' | | DATE: 11/20/98 | |
| DRN. JRT | TR. | CK. JRZ | |
| JOB NO. 98-0706 | PG. 2 OF 2 | | |

Exhibit 2

Property Deed RK-I

Legal Description

Sheet 1 of 2

Sanitary Sewer Easement Across RK Mechanical Parcel

A parcel of land situated in part of the Northeast Quarter of Section 28 and part of the Northwest Quarter of Section 27, Township 3 South, Range 67 West, of the 6th Principal Meridian, City and County of Denver, State of Colorado being more particularly described as follows:

Commencing at the Northeast Corner of said Section 28; thence along the Northerly line of said Section 28 S 89°40' 09" W a distance of 421.67 feet; thence departing said Northerly line S 00°28' 31" W a distance of 176.01 feet to the *POINT OF BEGINNING*; thence the following eight (8) courses:

1. S 62°39' 49" E, a distance of 68.41 feet;
2. S 26°52' 42" E, a distance of 197.49 feet;
3. S 73°55' 07" E, a distance of 319.88 feet;
4. S 26°58' 39" E, a distance of 140.68 feet;
5. S 02°45' 12" W, a distance of 80.66 feet;
6. N 26°58' 39" W, a distance of 193.35 feet;
7. N 73°55' 07" W, a distance of 319.93 feet;
8. N 26°52' 42" W, a distance of 270.39 feet to the *POINT OF BEGINNING*.

Said parcel contains 0.662 acres or 28,838 square feet more or less.

Basis of Bearing

The Easterly line of the Northeast Quarter of said Section 28 was found to be S 00°28' 31" E based upon the North American Datum of 1983 (1992 adjustment), Colorado Central Zone, a local network as established by the Colorado Department of Transportation, Region Six, Reference stations "King" and Ramp".

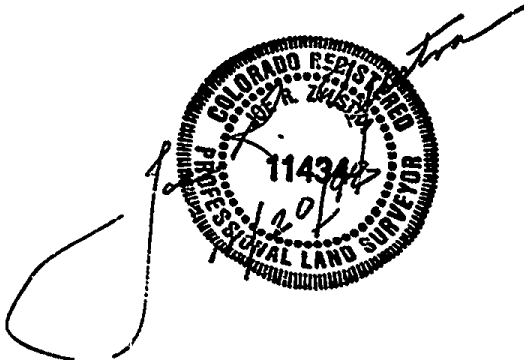

ZYLSTRA BAKER SURVEYING, INC.
1510 WEST TUFTS AVENUE
ENGLEWOOD, COLORADO 80110
PHONE (303) 781-0700

Exhibit 3
Property Deed RK-I

Legal Description

Sheet 1 of 2

Emergency Ingress and Egress Easement

A parcel of land situated in part of the Northeast Quarter of Section 28, Township 3 South, Range 67 West, of the 6th Principal Meridian, City and County of Denver, State of Colorado being more particularly described as follows:

Commencing at the Northeast Corner of said Section 28; thence along the Northerly line of said Section 28 S 89°40' 09" W a distance of 444.79 feet; thence departing said Northerly line Due South a distance of 229.50 feet to the *POINT OF BEGINNING*; thence the following four (4) courses:

1. N 89°43' 07" E, a distance of 50.00 feet;
2. Due South, a distance of 50.00 feet;
3. S 89°43' 07" W, a distance of 50.00 feet;
4. Due North, a distance of 50.00 feet to the *POINT OF BEGINNING*.

Said parcel contains 0.006 acres or 250 square feet more or less.

Basis of Bearing

The Northerly line of the Northeast Quarter of said Section 28 was found to be N 89°40' 09" E based upon the North American Datum of 1983 (1992 adjustment), Colorado Central Zone, a local network as established by the Colorado Department of Transportation, Region Six, Reference stations "King" and Ramp".

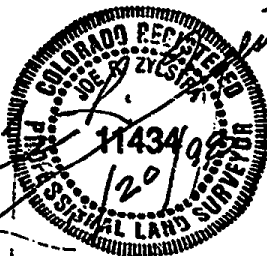

ZYLSTRA BAKER SURVEYING, INC.
1510 WEST TUFTS AVENUE
ENGLEWOOD, COLORADO 80110
PHONE (303) 781-0700

EXHIBIT 3 Property Deed RK-I Sheet 2

NE 1/4 SEC 28
T 3 S, R 67 W, 6TH P. M.
CITY AND COUNTY OF DENVER

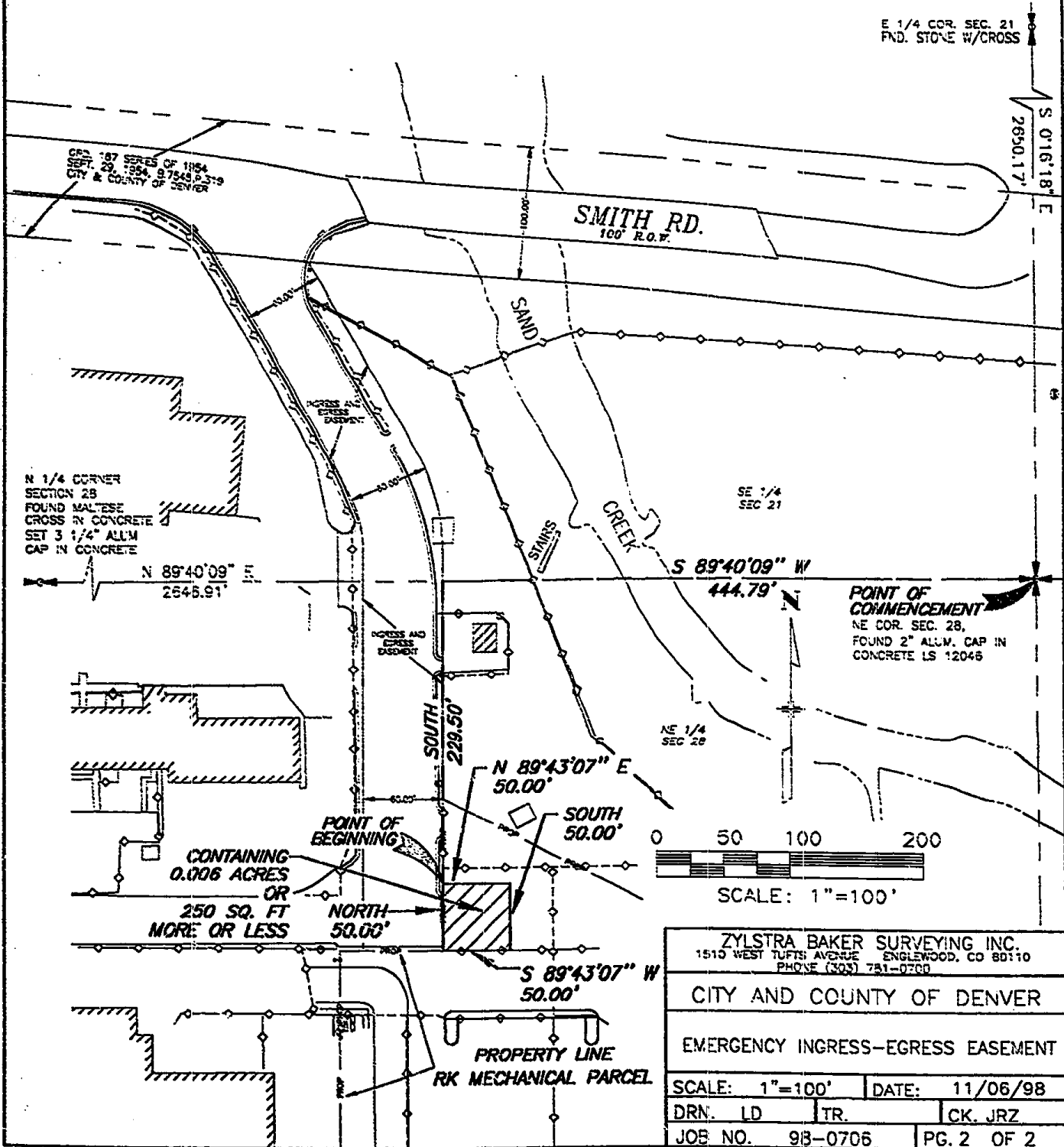

E 1/4 COR. SEC. 21
FND. STONE W/CROSS

CGS 187 SERIES OF 1154
NOV. 29, 1954, 97548 P. 3-9
CITY & COUNTY OF DENVER

N 1/4 CORNER
SECTION 28
FOUND MALTESE
CROSS IN CONCRETE
SET 3 1/4" ALLUM
CAP IN CONCRETE

POINT OF
COMMENCEMENT
NE COR. SEC. 28,
FOUND 2" ALLUM. CAP IN
CONCRETE LS 12045

CONTAINING
0.006 ACRES
OR
250 SQ. FT
MORE OR LESS

0 50 100 200
SCALE: 1"=100'

| | | |
|--|----------------|---------|
| ZYLSTRA BAKER SURVEYING INC. 1510 WEST TUFTS AVENUE ENGLEWOOD, CO 80110 PHONE (303) 781-0700 | | |
| CITY AND COUNTY OF DENVER | | |
| EMERGENCY INGRESS-EGRESS EASEMENT | | |
| SCALE: 1"=100' | DATE: 11/06/98 | |
| DRN. LD | TR. | CK. JRZ |
| JOB NO. 93-0706 | PG. 2 OF 2 | |

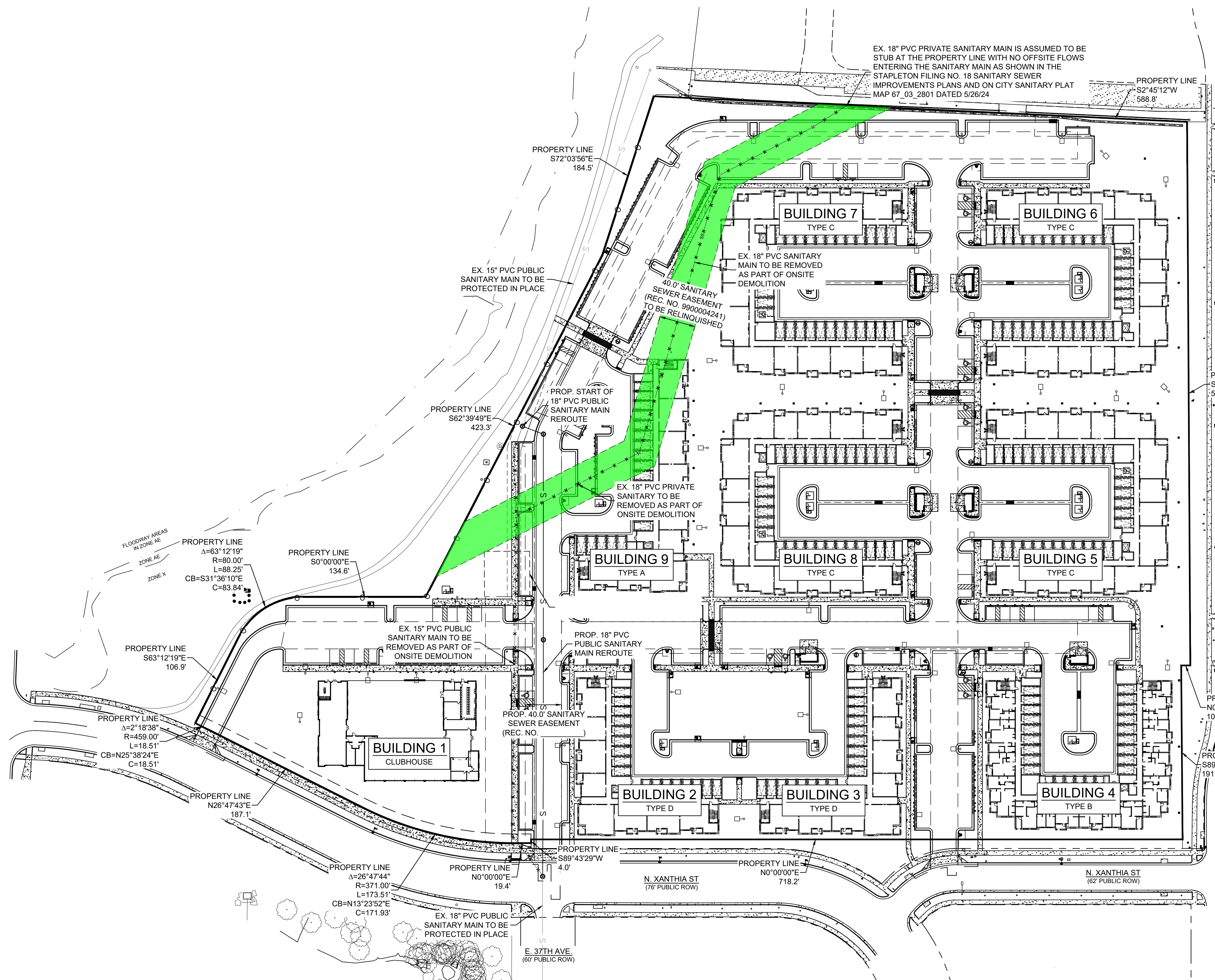

- LEGEND**
- PROPERTY LINE
 - EASEMENT RELINQUISHMENT
 - PROPOSED SANITARY SEWER
 - EXISTING SANITARY SEWER
 - EXISTING SANITARY SEWER TO BE REMOVED

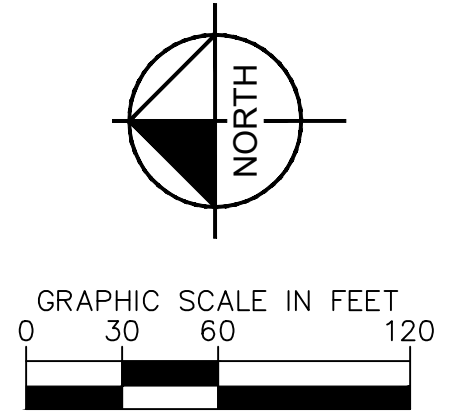

XANTHIA MULTI-FAMILY
EASEMENT RELINQUISHMENT
REC. NO. 9900004241
10/1/2024

Kimley»Horn

© 2024 KIMLEY-HORN AND ASSOCIATES, INC.
6200 S SYRACUSE WAY, SUITE 300, GREENWOOD VILLAGE CO 80111
PHONE: 303-228-2300

3800 N Xanthia St Relinquishment

02/25/2025

Master ID: 2022-PROJMSTR-0000336 **Project Type:** ROW Relinquishment
Review ID: 2024-RELINQ-0000018 **Review Phase:**
Location: 3800 N Xanthia St **Review End Date:** 11/06/2024

Any denials listed below must be rectified in writing to this office before project approval is granted.

Reviewing Agency: City Forester Review Review Status: Approved

Reviewers Name: Nick Evers
Reviewers Email: Nick.Evers@denvergov.org
Status Date: 11/06/2024
Status: Approved
Comments: Approved. No expected PRW tree conflict.

Reviewing Agency: Comcast Referral Review Status: Approved - No Response

Status Date: 11/07/2024
Status: Approved - No Response
Comments:

Reviewing Agency: Denver Water Referral Review Status: Approved

Status Date: 11/07/2024
Status: Approved
Comments: PWPRS Project Number: 2024-RELINQ-0000018 - 3800 N Xanthia St Relinquishment
Reviewing Agency/Company: Denver Water
Reviewers Name: Gina Begly
Reviewers Phone: 303-628-6219
Reviewers Email: gina.begly@denverwater.org
Approval Status: Approved

Comments:

Reviewing Agency: Survey Review Review Status: Approved

Reviewers Name: Kathy Svechovsky
Reviewers Email: Kathy.Svechovsky@denvergov.org
Status Date: 01/21/2025
Status: Approved
Comments: PWPRS Project Number: 2024-RELINQ-0000018 - 3800 N Xanthia St Relinquishment
Reviewing Agency/Company: DOTI/ROW
Reviewers Name: Kathy Svechovsky
Reviewers Phone: 720-865-3127
Reviewers Email: kathy.svechovsky@denvergov.org
Approval Status: Approved

Comments:

Status Date: 11/06/2024

Comment Report

3800 N Xanthia St Relinquishment

02/25/2025

Master ID: 2022-PROJMSTR-0000336 **Project Type:** ROW Relinquishment
Review ID: 2024-RELINQ-0000018 **Review Phase:**
Location: 3800 N Xanthia St **Review End Date:** 11/06/2024

Any denials listed below must be rectified in writing to this office before project approval is granted.

Status: Denied
Comments: See survey comments.

Reviewing Agency: Case Manager Review/Finalize **Review Status:** Comments Compiled

Reviewers Name: Jessica Eusebio
Reviewers Email: Jessica.Eusebio@denvergov.org

Status Date: 11/07/2024
Status: Comments Compiled
Comments:

Status Date: 10/18/2024
Status: Confirmation of Payment
Comments:

Reviewing Agency: Metro Wastewater Referral **Review Status:** Approved - No Response

Status Date: 11/07/2024
Status: Approved - No Response
Comments:

Reviewing Agency: Office of Emergency Management Referral **Review Status:** Approved - No Response

Status Date: 11/07/2024
Status: Approved - No Response
Comments:

Reviewing Agency: Parks and Recreation Review **Review Status:** Approved - No Response

Status Date: 11/07/2024
Status: Approved - No Response
Comments:

Reviewing Agency: Construction Engineering Review **Review Status:** Approved

Reviewers Name: Kim Blair
Reviewers Email: Kim.Blair@denvergov.org

Status Date: 11/06/2024
Status: Approved
Comments: No Objection.

Reviewing Agency: Policy and Planning Review **Review Status:** Approved - No Response

Reviewers Name: Jennifer Hillhouse
Reviewers Email: Jennifer.Hillhouse@denvergov.org

Status Date: 11/07/2024

2024-RELINQ-0000018

Comment Report

3800 N Xanthia St Relinquishment

02/25/2025

Master ID: 2022-PROJMSTR-0000336 **Project Type:** ROW Relinquishment
Review ID: 2024-RELINQ-0000018 **Review Phase:**
Location: 3800 N Xanthia St **Review End Date:** 11/06/2024

Any denials listed below must be rectified in writing to this office before project approval is granted.

Status: Approved - No Response
Comments:

Reviewing Agency: TES Sign and Stripe Review Review Status: Approved - No Response

Reviewers Name: Brittany Price
Reviewers Email: Brittany.Price@denvergov.org

Status Date: 11/07/2024
Status: Approved - No Response
Comments:

Reviewing Agency: CenturyLink Referral Review Status: Approved - No Response

Status Date: 11/07/2024
Status: Approved - No Response
Comments:

Reviewing Agency: Xcel Referral Review Status: Approved

Status Date: 11/07/2024
Status: Approved
Comments: PWPRS Project Number: 2024-RELINQ-0000018 - 3800 N Xanthia St Relinquishment
Reviewing Agency/Company: Public Service Company of Colorado (PSCo) dba Xcel Energy
Reviewers Name: Donna George
Reviewers Phone: 3035713306
Reviewers Email: Donna.L.George@xcelenergy.com
Approval Status: Approved

Comments:

Reviewing Agency: City Councilperson and Aides Referral Review Status: Approved - No Response

Status Date: 11/07/2024
Status: Approved - No Response
Comments:

Reviewing Agency: RTD Referral Review Status: Approved w/Conditions

Status Date: 11/07/2024
Status: Approved w/Conditions
Comments: PWPRS Project Number: 2024-RELINQ-0000018 - 3800 N Xanthia St Relinquishment
Reviewing Agency/Company: RTD
Reviewers Name: Steve Smith
Reviewers Phone: 3032996946
Reviewers Email: steven.smith@rtd-denver.com
Approval Status: Approved with conditions

Comments:
RTD staff have reviewed the submittal and have the following comments:

Comment Report

3800 N Xanthia St Relinquishment

02/25/2025

Master ID: 2022-PROJMSTR-0000336 **Project Type:** ROW Relinquishment
Review ID: 2024-RELINQ-0000018 **Review Phase:**
Location: 3800 N Xanthia St **Review End Date:** 11/06/2024

Any denials listed below must be rectified in writing to this office before project approval is granted.

- Bus Operations - No exceptions
- Bus Stop Program - No exceptions
- Commuter Rail - No exceptions
- Construction Management - No exceptions
- Engineering - No exceptions
- Light Rail - No exceptions
- Real Property - No exceptions
- Service Development - No exceptions
- Transit Oriented Development - No exceptions
- Utilities - No exceptions

This review is for Design concepts and to identify any necessary improvements to RTD stops and property affected by the design. This review of the plans does not eliminate the need to acquire, and/or go through the acquisition process of any agreements, easements or permits that may be required by the RTD for any work on or around our facilities and property.

Reviewing Agency: CDOT Referral

Review Status: Approved

Status Date: 11/07/2024
Status: Approved
Comments: PWPRS Project Number: 2024-RELINQ-0000018 - 3800 N Xanthia St Relinquishment
Reviewing Agency/Company: CDOT
Reviewers Name: Michelle White
Reviewers Phone: 3035124218
Reviewers Email: michelle.m.white@state.co.us
Approval Status: Approved

Comments:
This is not on CDOT's system. We have no comment.

Reviewing Agency: ER Transportation

Review Status: Approved

Status Date: 01/24/2025
Status: PWPRS Project Number: 2024-RELINQ-0000018 - 3800 N Xanthia St Relinquishment
Comments: Reviewing Agency/Company: ER Transportation
Reviewers Name: Jessica Eusebio
Reviewers Phone: 3035124218
Reviewers Email: Jessica.eusebio@denvergov.org
Approval Status: Approved

Comments:
Confirmed that this is a partial relinquishment and the access easement is going to remain. Updated application in review documents.

Status Date: 11/07/2024
Status: Denied
Comments: PWPRS Project Number: 2024-RELINQ-0000018 - 3800 N Xanthia St Relinquishment
Reviewing Agency/Company: ER Transportation
Reviewers Name: Jessica Eusebio
Reviewers Phone: 3035124218
Reviewers Email: Jessica.eusebio@denvergov.org
Approval Status: Denied

3800 N Xanthia St Relinquishment

02/25/2025

Master ID: 2022-PROJMSTR-0000336 **Project Type:** ROW Relinquishment
Review ID: 2024-RELINQ-0000018 **Review Phase:**
Location: 3800 N Xanthia St **Review End Date:** 11/06/2024

Any denials listed below must be rectified in writing to this office before project approval is granted.

Comments: **Comments:**
 Confirmation with the applicant to determine if access easement is also to be relinquished. Will need to determine how to proceed with application at that point.

Reviewing Agency: DS Project Coordinator **Review Status:** Approved - No Response

Reviewers Name: James Larsen
Reviewers Email: james.larsen@denvergov.org

Status Date: 11/06/2024
Status: Approved
Comments: Approved. No expected PRW tree conflict.

Reviewing Agency: DES Transportation **Review Status:** Approved

Status Date: 11/07/2024
Status: Approved
Comments: PWPRS Project Number: 2024-RELINQ-0000018 - 3800 N Xanthia St Relinquishment
 Reviewing Agency/Company: DS Transportation
 Reviewers Name: Christopher Mueller
 Reviewers Phone: 303-628-6219
 Reviewers Email: christopher.mueller@denvergov.org
 Approval Status: Approved

Comments: APPROVED AS RESIDENTIAL PROPERTIES TO THE EAST ARE SERVED BY A DIFFERENT SANITARY SEWER MAIN.

Reviewing Agency: DES Wastewater **Review Status:** Approved

Reviewers Name: Brenden Marron
Reviewers Email: brenden.marron@denvergov.org

Status Date: 01/02/2025
Status: Approved
Comments: Sanitary televising received. Based on ALTA and televising it does not appear sanitary serves off-site structures. Approved on behalf of Wastewater

Status Date: 11/06/2024
Status: Denied
Comments: Push camera televising of private sanitary main received. Comments on video provided. The video was inconclusive due to camera being submerged. Once extent of existing is confirmed and plug shown to confirm there are no off-site connections status will be updated.

3800 N Xanthia St Relinquishment

02/25/2025

| | | | |
|-------------------|-----------------------|-------------------------|--------------------|
| Master ID: | 2022-PROJMSTR-0000336 | Project Type: | ROW Relinquishment |
| Review ID: | 2024-RELINQ-0000018 | Review Phase: | |
| Location: | 3800 N Xanthia St | Review End Date: | 11/06/2024 |

Any denials listed below must be rectified in writing to this office before project approval is granted.

Reviewing Agency: Denver Fire

Review Status: Approved

Status Date: 11/07/2024
Status: Approved
Comments: PWPRS Project Number: 2024-RELINQ-0000018 - 3800 N Xanthia St Relinquishment
Reviewing Agency/Company: Denver Fire
Reviewers Name: Brian Dimock
Reviewers Phone: 3035124218
Reviewers Email: brian.dimock@denvergov.org
Approval Status: Approved

Comments:

Reviewing Agency: Landmark

Review Status: Approved - No Response

Status Date: 11/07/2024
Status: Approved - No Response
Comments:

Reviewing Agency: Asset Management

Review Status: Approved

Reviewers Name: Kathryn Spritzer
Reviewers Email: Kathryn.spritzer@denvergov.org

Status Date: 11/06/2024
Status: Approved
Comments: